

CDx4HC374 高速 CMOS ロジック・オクタール D タイプ・フリップ・フロップ、 3 ステート・ポジティブ・エッジ・トリガ

1 特長

- バッファ付き入力
- 共通の 3 ステート出力イネーブル制御
- 3 ステート出力
- バス・ライン駆動能力
- 15ns の伝搬遅延 (クロックから Q、標準値、 $V_{CC} = 5V$ 、 $C_L = 15pF$ 、 $T_A = 25^\circ C$)
- ファンアウト (全温度範囲にわたって)
 - 標準出力: 10 個の LSTTL 負荷
 - バス・ドライバ出力: 15 個の LSTTL 負荷
- 広い動作温度範囲: $-55^\circ C \sim 125^\circ C$
- 平衡な伝搬遅延と遷移時間
- LSTTL ロジック IC に比べて消費電力を大幅削減
- HC タイプ
 - 2V~6V で動作
 - 優れたノイズ耐性: V_{CC} に対して $N_{IL} = 30\%$ 、 $N_{IH} = 30\%$ ($V_{CC} = 5V$ 時)
- HCT タイプ
 - 4.5V~5.5V で動作
 - LSTTL 入力ロジックと直接互換、 $V_{IL} = 0.8V$ (最大値)、 $V_{IH} = 2V$ (最小値)
 - CMOS 入力互換、 V_{OL} 、 V_{OH} で $I_L \leq 1\mu A$

2 概要

'HC374、'HCT374、'HC574、'HCT574 は、15 個の LSTTL 負荷を駆動できる 3 ステート出力付きオクタール D タイプ・フリップフロップです。8 つのエッジ・トリガ・フリップ・フロップが、クロック (CP) の LOW から HIGH への遷移でデータをレジスタに入力します。出力イネーブル (\overline{OE}) は 3 ステート出力を制御します。OE は、レジスタの動作の影響を受けません。 \overline{OE} が HIGH の場合、出力は高インピーダンス状態になります。374 と 574 は機能の点では同じであり、ピン配置のみが異なります。

製品情報

部品番号	パッケージ ⁽¹⁾	本体サイズ (公称)
CD54HC374F3A	CDIP (20)	26.92mm × 6.92mm
CD54HC574F	CDIP (20)	26.92mm × 6.92mm
CD54HCT374F3A	CDIP (20)	26.92mm × 6.92mm
CD54HCT574F	CDIP (20)	26.92mm × 6.92mm
CD74HC374M	SOIC (20)	12.80mm × 7.50mm
CD74HC574M	SOIC (20)	12.80mm × 7.50mm
CD74HCT374M	SOIC (20)	12.80mm × 7.50mm
CD74HCT574M	SOIC (20)	12.80mm × 7.50mm
CD74HC374E	PDIP (20)	25.40mm × 6.35mm
CD74HC574E	PDIP (20)	25.40mm × 6.35mm
CD74HCT374E	PDIP (20)	25.40mm × 6.35mm
CD74HCT574E	PDIP (20)	25.40mm × 6.35mm
CD74HCT574PWR	TSSOP (20)	6.50mm × 4.40mm

(1) 利用可能なパッケージについては、このデータシートの末尾にある注文情報を参照してください。

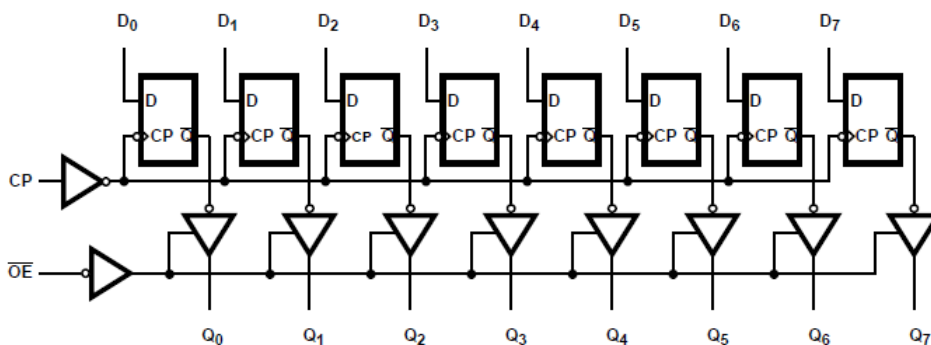

機能ダイアグラム



Table of Contents

<p>1 特長..... 1</p> <p>2 概要..... 1</p> <p>3 Revision History..... 2</p> <p>4 Pin Configuration and Functions..... 3</p> <p>5 Specifications..... 4</p> <p> 5.1 Absolute Maximum Ratings..... 4</p> <p> 5.2 Recommended Operating Conditions..... 4</p> <p> 5.3 Thermal Information..... 4</p> <p> 5.4 Electrical Characteristics..... 5</p> <p> 5.5 Prerequisite for Switching Characteristics..... 6</p> <p> 5.6 Switching Characteristics..... 7</p> <p>6 Parameter Measurement Information..... 8</p> <p>7 Detailed Description..... 10</p> <p> 7.1 Overview..... 10</p>	<p> 7.2 Functional Block Diagram..... 10</p> <p> 7.3 Device Functional Modes..... 10</p> <p>8 Power Supply Recommendations..... 11</p> <p>9 Layout..... 11</p> <p> 9.1 Layout Guidelines..... 11</p> <p>10 Device and Documentation Support..... 12</p> <p> 10.1 Receiving Notification of Documentation Updates.. 12</p> <p> 10.2 サポート・リソース..... 12</p> <p> 10.3 Trademarks..... 12</p> <p> 10.4 Electrostatic Discharge Caution..... 12</p> <p> 10.5 Glossary..... 12</p> <p>11 Mechanical, Packaging, and Orderable Information..... 12</p>
--	--

3 Revision History

資料番号末尾の英字は改訂を表しています。その改訂履歴は英語版に準じています。

Changes from Revision D (January 2022) to Revision E (October 2022)	Page
• Increased R θ JA for packages: DW (58 to 109.1); N (69 to 84.6); PW (83 to 131.8).....	4

Changes from Revision C (May 2004) to Revision D (January 2022)	Page
• 最新のデータシート規格を反映するように、文書全体の採番、書式設定、表、図、相互参照を更新.....	1

4 Pin Configuration and Functions

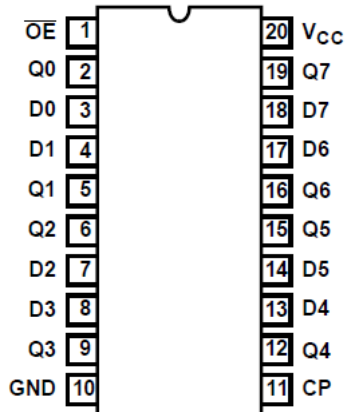

HC(T) 374
 J, DW, or N package
 20-Pin CDIP, SOIC, or PDIP
 Top View

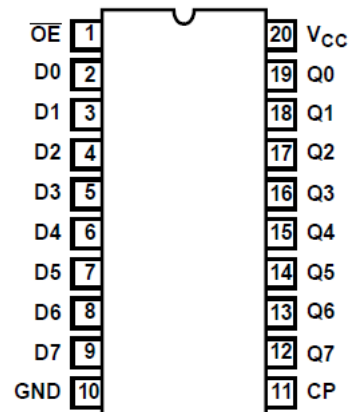

HC(T) 574
 J, DW, N, or PW package
 20-Pin CDIP, SOIC, PDIP, or TSSOP
 Top View

5 Specifications

5.1 Absolute Maximum Ratings

over operating free-air temperature range (unless otherwise noted)⁽¹⁾

		MIN	MAX	UNIT
V _{CC}	Supply voltage	-0.5	7	V
I _{IK}	Input diode current	For V _I < -0.5 V or V _I > V _{CC} + 0.5 V		±20 mA
I _{OK}	Output diode current	For V _O < -0.5 V or V _O > V _{CC} + 0.5 V		±20 mA
I _O	Drain current, per output	For -0.5 V < V _O < V _{CC} + 0.5 V		±35 mA
I _O	Output source or sink current per output pin	For V _O > -0.5 V or V _O < V _{CC} + 0.5 V		±25 mA
	Continuous current through V _{CC} or ground current		±50	mA
T _J	Junction temperature		150	°C
T _{stg}	Storage temperature range	-65	150	°C
	Lead temperature (Soldering 10s) (SOIC - Lead Tips Only)		300	°C

- (1) Stresses beyond those listed under *absolute maximum ratings* may cause permanent damage to the device. These are stress ratings only and functional operation of the device at these or any other conditions beyond those indicated under *recommended operating conditions* is not implied. Exposure to absolute-maximum-rated conditions for extended periods may affect device reliability.

5.2 Recommended Operating Conditions

		MIN	MAX	UNIT	
V _{CC}	Supply voltage range	HC types	2	6	V
		HCT types	4.5	5.5	
V _I , V _O	DC input or output voltage	0	V _{CC}	V	
	Input rise and fall time	2 V		1000	ns
		4.5 V		500	
		6 V		400	
T _A	Temperature range	-55	125	°C	

5.3 Thermal Information

THERMAL METRIC		DW (SOIC)	N (PDIP)	PW (TSSOP)	UNIT
		20 PINS	20 PINS	20 PINS	
R _{θJA}	Junction-to-ambient thermal resistance ⁽¹⁾	109.1	84.6	131.8	°C/W
R _{θJC(top)}	Junction-to-case (top) thermal resistance	76	72.5	72.2	°C/W
R _{θJB}	Junction-to-board thermal resistance	77.6	65.3	82.8	°C/W
ψ _{JT}	Junction-to-top characterization parameter	51.5	55.3	21.5	°C/W
ψ _{JB}	Junction-to-board characterization parameter	77.1	65.2	82.4	°C/W
R _{θJC(bot)}	Junction-to-case (bottom) thermal resistance	N/A	N/A	N/A	°C/W

- (1) For more information about traditional and new thermal metrics, see the [Semiconductor and IC package thermal metrics](#) application report.

5.4 Electrical Characteristics

PARAMETER		TEST CONDITIONS ⁽²⁾	V _{CC} (V)	25°C			–40°C to 85°C		–55°C to 125°C		UNIT
				MIN	TYP	MAX	MIN	MAX	MIN	MAX	
HC TYPES											
V _{IH}	High level input voltage		2	1.5		1.5		1.5		V	
			4.5	3.15		3.15		3.15			
			6	4.2		4.2		4.2			
V _{IL}	Low level input voltage		2		0.5		0.5		0.5	V	
			4.5		1.35		1.35		1.35		
			6		1.8		1.8		1.8		
V _{OH}	High level output voltage CMOS loads	I _{OH} = – 20 μA	2	1.9		1.9		1.9		V	
		I _{OH} = – 20 μA	4.5	4.4		4.4		4.4			
		I _{OH} = – 20 μA	6	5.9		5.9		5.9			
	High level output voltage TTL loads	I _{OH} = – 6 mA	4.5	3.98		3.84		3.7		V	
		I _{OH} = – 7.8 mA	6	5.48		5.34		5.2			
V _{OL}	Low level output voltage CMOS loads	I _{OL} = 20 μA	2		0.1		0.1		0.1	V	
		I _{OL} = 20 μA	4.5		0.1		0.1		0.1		
		I _{OL} = 20 μA	6		0.1		0.1		0.1		
	Low level output voltage TTL loads	I _{OL} = 6 mA	4.5		0.26		0.33		0.4	V	
		I _{OL} = 7.8 mA	6		0.26		0.33		0.4		
I _I	Input leakage current	V _I = V _{CC} or GND	6		±0.1		±1		±1	μA	
I _{CC}	Quiescent device current	V _I = V _{CC} or GND	6		8		80		160	μA	
V _{IL} or V _{IH}	Three-state leakage current	V _O = V _{CC} or GND	6		±0.5		±5.0		±10	μA	
HCT TYPES											
V _{IH}	High level input voltage		4.5 to 5.5	2		2		2		V	
V _{IL}	Low level input voltage		4.5 to 5.5		0.8		0.8		0.8	V	
V _{OH}	High level output voltage CMOS loads	I _{OH} = – 20 μA	4.5	4.4		4.4		4.4		V	
	High level output voltage TTL loads	I _{OH} = – 6 mA	4.5	3.98		3.84		3.7			
V _{OL}	Low level output voltage CMOS loads	I _{OL} = 20 μA	4.5		0.1		0.1		0.1	V	
	Low level output voltage TTL loads	I _{OL} = 6 mA	4.5		0.26		0.33		0.4		
I _I	Input leakage current	V _I = V _{CC} or GND	5.5		±0.1		±1		±1	μA	
I _{CC}	Quiescent device current	V _I = V _{CC} or GND	5.5		8		80		160	μA	
V _{IL} or V _{IH}	Three-state leakage current	V _O = V _{CC} or GND	6		±0.5		±5.0		±10	μA	

5.4 Electrical Characteristics (continued)

PARAMETER		TEST CONDITIONS ⁽²⁾	V _{CC} (V)	25°C			-40°C to 85°C		-55°C to 125°C		UNIT
				MIN	TYP	MAX	MIN	MAX	MIN	MAX	
ΔI _{CC} ⁽¹⁾	HCT374 Additional quiescent device current per input pin	D0 - D7 inputs held at V _{CC} - 2.1	4.5 to 5.5		100	108		135		147	μA
		CP input held at V _{CC} - 2.1	4.5 to 5.5		100	324		405		441	μA
		OE input held at V _{CC} - 2.1	4.5 to 5.5		100	468		585		637	μA
	HCT574 Additional quiescent device current per input pin	D0 - D7 inputs held at V _{CC} - 2.1	4.5 to 5.5		100	144		180		196	μA
		CP input held at V _{CC} - 2.1	4.5 to 5.5		100	270		337.5		367.5	μA
		OE input held at V _{CC} - 2.1	4.5 to 5.5		100	216		270		294	μA

(1) For dual-supply systems, theoretical worst case (V_I = 2.4 V, V_{CC} = 5.5 V) specification is 1.8 mA.

(2) V_I = V_{IH} or V_{IL}, unless otherwise noted.

5.5 Prerequisite for Switching Characteristics

PARAMETER		V _{CC} (V)	25°C			-40°C to 85°C			-55°C to 125°C			UNIT
			MIN	TYP	MAX	MIN	TYP	MAX	MIN	TYP	MAX	
HC TYPES												
f _{MAX}	Maximum clock frequency	2	6		5		4				MHz	
		4.5	30		25		20					
		6	35		29		23					
t _W	Clock pulse width	2	80		100		120				ns	
		4.5	16		20		24					
		6	14		17		20					
t _{SU}	Setup time data to clock	2	60		75		90				ns	
		4.5	12		15		18					
		6	10		13		15					
t _H	Hold time data to clock	2	5		5		5				ns	
		4.5	5		5		5					
		6	5		5		5					
HCT TYPES												
f _{MAX}	Maximum clock frequency	4.5	30		25		20				MHz	
t _W	Clock pulse width	4.5	16		20		24				ns	
t _{SU}	Setup time data to clock	4.5	12		15		18				ns	
t _H	Hold time data to clock	4.5	5		5		5				ns	

5.6 Switching Characteristics

 $C_L = 50 \text{ pF}$, Input t_r , $t_f = 6 \text{ ns}$

PARAMETER		TEST CONDITIONS	V_{CC} (V)	25°C			–40°C to 85°C		–55°C to 125°C		UNIT
				MIN	TYP	MAX	MIN	MAX	MIN	MAX	
HC TYPES											
t_{PLH} , t_{PHL}	Propagation delay Clock to output	$C_L = 50 \text{ pF}$	2		165		205		250	ns	
			4.5		33		41		50		
		$C_L = 15 \text{ pF}$	5		15					ns	
t_{PLZ} , t_{PHZ}	Output disable to Q	$C_L = 50 \text{ pF}$	2		135		170		205	ns	
			4.5		27		34		41		
		$C_L = 15 \text{ pF}$	5		11					ns	
t_{PZL} , t_{PZH}	Output enable to Q	$C_L = 50 \text{ pF}$	2		150		190		225	ns	
			4.5		30		38		45		
		$C_L = 15 \text{ pF}$	5		12					ns	
f_{MAX}	Maximum clock frequency	$C_L = 15 \text{ pF}$	5		60					MHz	
			6								
			6								
t_{THL} , t_{TLH}	Output transition time	$C_L = 50 \text{ pF}$	2		60		75		90	ns	
			4.5		12		15		18		
			6		10		13		15		
C_I	Input capacitance	$C_L = 50 \text{ pF}$		10	10		10	10	pF		
C_O	Three-state output capacitance			20	20		20	20	pF		
C_{PD}	Power dissipation capacitance ^{(1) (2)}	$C_L = 15 \text{ pF}$	5		39					pF	
HCT TYPES											
t_{PHL} , t_{PLH}	Propagation delay Clock to output	$C_L = 50 \text{ pF}$	4.5		33		41		50	ns	
		$C_L = 15 \text{ pF}$	5		15						
t_{PLZ} , t_{PHZ}	Output disable to Q	$C_L = 50 \text{ pF}$	4.5		28		35		42	ns	
		$C_L = 15 \text{ pF}$	5		11						
t_{PZL} , t_{PZH}	Output enable to Q	$C_L = 50 \text{ pF}$	4.5		30		38		45	ns	
		$C_L = 15 \text{ pF}$	5		12						
f_{MAX}	Maximum clock frequency	$C_L = 15 \text{ pF}$	5		60					MHz	
			6								
			6								
t_{TLH} , t_{THL}	Output transition time	$C_L = 50 \text{ pF}$	4.5		12		15		18	ns	
			6								
			6								
C_I	Input capacitance	$C_L = 50 \text{ pF}$		10	10		10	10	pF		
C_O	Three-state output capacitance			20	20		20	20	pF		
C_{PD}	Power dissipation capacitance ^{(1) (2)}	$C_L = 15 \text{ pF}$	5		47					pF	

(1) C_{PD} is used to determine the dynamic power consumption, per package.

(2) $P_D = C_{PD} V_{CC}^2 f_i + \sum V_{CC}^2 f_o C_L$ where f_i = input frequency, f_o = output frequency, C_L = output load capacitance, V_{CC} = supply voltage.

6 Parameter Measurement Information

Phase relationships between waveforms were chosen arbitrarily. All input pulses are supplied by generators having the following characteristics: $PRR \leq 1$ MHz, $Z_O = 50 \Omega$, $t_t < 6$ ns.

For clock inputs, f_{max} is measured when the input duty cycle is 50%.

The outputs are measured one at a time with one input transition per measurement.

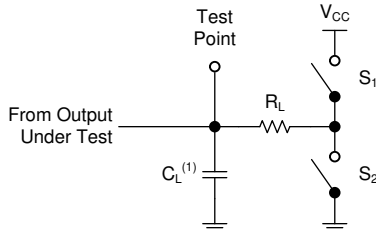

(1) C_L includes probe and test-fixture capacitance.

Figure 6-1. Load Circuit for 3-State Outputs

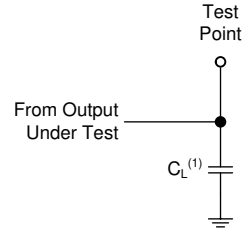

(1) C_L includes probe and test-fixture capacitance.

Figure 6-2. Load Circuit for Push-Pull Outputs

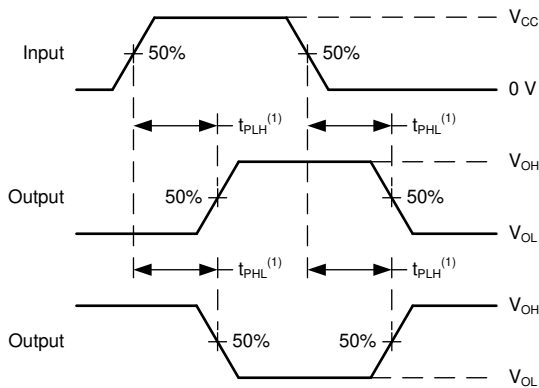

(1) The greater between t_{PLH} and t_{PHL} is the same as t_{pd} .

Figure 6-3. Voltage Waveforms, Propagation Delays for Standard CMOS Inputs

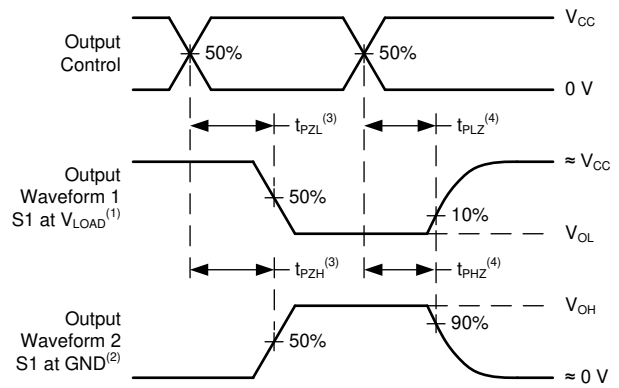

(1) S1 = CLOSED; S2 = OPEN.

(2) S1 = OPEN; S2 = CLOSED.

(3) t_{PZL} and t_{PHZ} are the same as t_{dis} .

(4) t_{PZL} and t_{PZH} are the same as t_{en} .

Figure 6-4. Voltage Waveforms, Standard CMOS Inputs Propagation Delays

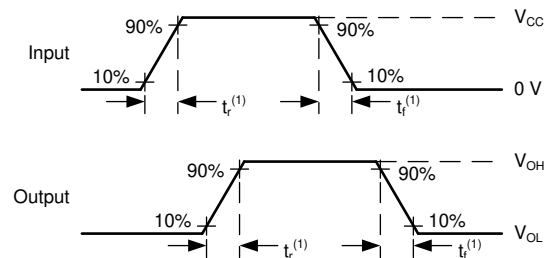

(1) The greater between t_r and t_f is the same as t_t .

Figure 6-5. Voltage Waveforms, Input and Output Transition Times for Standard CMOS Inputs

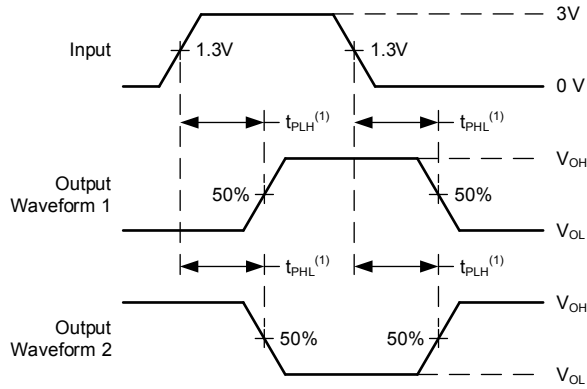

(1) The greater between t_{PLH} and t_{PHL} is the same as t_{pd} .

6-6. Voltage Waveforms, Propagation Delays for TTL-Compatible Inputs

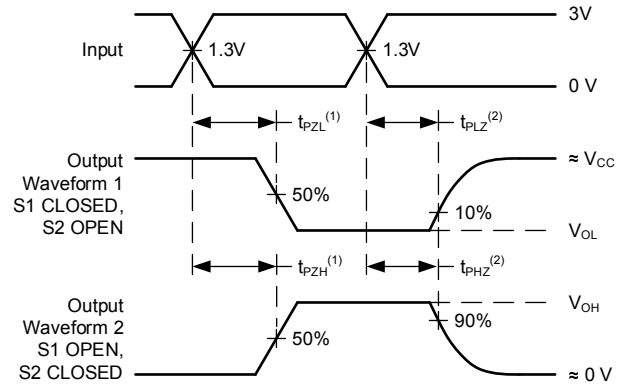

(1) t_{PLZ} and t_{PHZ} are the same as t_{dis} .

(2) t_{PZL} and t_{PZH} are the same as t_{en} .

6-7. Voltage Waveforms, TTL-Compatible CMOS Inputs Propagation Delays

7 Detailed Description

7.1 Overview

The 'HC374, 'HCT374, 'HC574, and 'HCT574 are octal D-type flip-flops with 3-state outputs and the capability to drive 15 LSTTL loads. The eight edge-triggered flip-flops enter data into their registers on the LOW to HIGH transition of clock (CP). The output enable (\overline{OE}) controls the 3-state outputs and is independent of the register operation. When \overline{OE} is HIGH, the outputs are in the high-impedance state. The 374 and 574 are identical in function and differ only in their pinout arrangements.

7.2 Functional Block Diagram

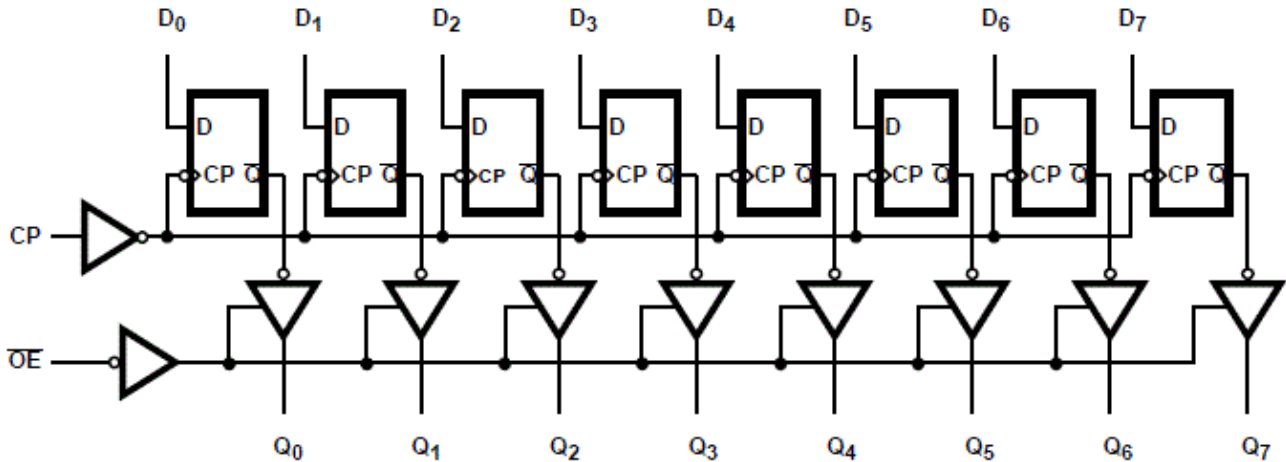

7.3 Device Functional Modes

表 7-1. Truth Table⁽¹⁾

INPUTS			OUTPUT
\overline{OE}	CP	Dn	Qn
L	↑	H	H
L	↑	L	L
L	L	X	Q0
H	X	X	Z

- (1) H = high level (steady state), L = low level (steady state), X = don't care, ↑ = transition from low to high level, Q0 = the level of Q before the indicated steady-state input conditions were established, Z = high impedance state

8 Power Supply Recommendations

The power supply can be any voltage between the minimum and maximum supply voltage rating located in the *Recommended Operating Conditions*. Each V_{CC} terminal should have a good bypass capacitor to prevent power disturbance. A 0.1- μ F capacitor is recommended for this device. It is acceptable to parallel multiple bypass capacitors to reject different frequencies of noise. The 0.1- μ F and 1- μ F capacitors are commonly used in parallel. The bypass capacitor should be installed as close to the power terminal as possible for best results.

9 Layout

9.1 Layout Guidelines

When using multiple-input and multiple-channel logic devices, inputs must not ever be left floating. In many cases, functions or parts of functions of digital logic devices are unused; for example, when only two inputs of a triple-input AND gate are used or only 3 of the 4 buffer gates are used. Such unused input pins must not be left unconnected because the undefined voltages at the outside connections result in undefined operational states. All unused inputs of digital logic devices must be connected to a logic high or logic low voltage, as defined by the input voltage specifications, to prevent them from floating. The logic level that must be applied to any particular unused input depends on the function of the device. Generally, the inputs are tied to GND or V_{CC} , whichever makes more sense for the logic function or is more convenient.

10 Device and Documentation Support

TI offers an extensive line of development tools. Tools and software to evaluate the performance of the device, generate code, and develop solutions are listed below.

10.1 Receiving Notification of Documentation Updates

To receive notification of documentation updates, navigate to the device product folder on ti.com. Click on *Subscribe to updates* to register and receive a weekly digest of any product information that has changed. For change details, review the revision history included in any revised document.

10.2 サポート・リソース

TI E2E™ サポート・フォーラムは、エンジニアが検証済みの回答と設計に関するヒントをエキスパートから迅速かつ直接得ることができる場所です。既存の回答を検索したり、独自の質問をしたりすることで、設計に必要な支援を迅速に得ることができます。

リンクされているコンテンツは、該当する貢献者により、現状のまま提供されるものです。これらは TI の仕様を構成するものではなく、必ずしも TI の見解を反映したものではありません。TI の [使用条件](#) を参照してください。

10.3 Trademarks

TI E2E™ is a trademark of Texas Instruments.

すべての商標は、それぞれの所有者に帰属します。

10.4 Electrostatic Discharge Caution



This integrated circuit can be damaged by ESD. Texas Instruments recommends that all integrated circuits be handled with appropriate precautions. Failure to observe proper handling and installation procedures can cause damage.

ESD damage can range from subtle performance degradation to complete device failure. Precision integrated circuits may be more susceptible to damage because very small parametric changes could cause the device not to meet its published specifications.

10.5 Glossary

[TI Glossary](#) This glossary lists and explains terms, acronyms, and definitions.

11 Mechanical, Packaging, and Orderable Information

The following pages include mechanical, packaging, and orderable information. This information is the most current data available for the designated devices. This data is subject to change without notice and revision of this document. For browser-based versions of this data sheet, refer to the left-hand navigation.

PACKAGING INFORMATION

Orderable part number	Status (1)	Material type (2)	Package Pins	Package qty Carrier	RoHS (3)	Lead finish/ Ball material (4)	MSL rating/ Peak reflow (5)	Op temp (°C)	Part marking (6)
5962-8974201RA	Active	Production	CDIP (J) 20	20 TUBE	No	SNPB	N/A for Pkg Type	-55 to 125	5962-8974201RA CD54HCT574F3A
CD54HC374F3A	Active	Production	CDIP (J) 20	20 TUBE	No	SNPB	N/A for Pkg Type	-55 to 125	8407101RA CD54HC374F3A
CD54HC374F3A.A	Active	Production	CDIP (J) 20	20 TUBE	No	SNPB	N/A for Pkg Type	-55 to 125	8407101RA CD54HC374F3A
CD54HC574F	Active	Production	CDIP (J) 20	20 TUBE	No	SNPB	N/A for Pkg Type	-55 to 125	CD54HC574F
CD54HC574F.A	Active	Production	CDIP (J) 20	20 TUBE	No	SNPB	N/A for Pkg Type	-55 to 125	CD54HC574F
CD54HC574F3A	Active	Production	CDIP (J) 20	20 TUBE	No	SNPB	N/A for Pkg Type	-55 to 125	CD54HC574F3A
CD54HC574F3A.A	Active	Production	CDIP (J) 20	20 TUBE	No	SNPB	N/A for Pkg Type	-55 to 125	CD54HC574F3A
CD54HCT374F3A	Active	Production	CDIP (J) 20	20 TUBE	No	SNPB	N/A for Pkg Type	-55 to 125	8550701RA CD54HCT374F3A
CD54HCT374F3A.A	Active	Production	CDIP (J) 20	20 TUBE	No	SNPB	N/A for Pkg Type	-55 to 125	8550701RA CD54HCT374F3A
CD54HCT574F	Active	Production	CDIP (J) 20	20 TUBE	No	SNPB	N/A for Pkg Type	-55 to 125	CD54HCT574F
CD54HCT574F.A	Active	Production	CDIP (J) 20	20 TUBE	No	SNPB	N/A for Pkg Type	-55 to 125	CD54HCT574F
CD54HCT574F3A	Active	Production	CDIP (J) 20	20 TUBE	No	SNPB	N/A for Pkg Type	-55 to 125	5962-8974201RA CD54HCT574F3A
CD54HCT574F3A.A	Active	Production	CDIP (J) 20	20 TUBE	No	SNPB	N/A for Pkg Type	-55 to 125	5962-8974201RA CD54HCT574F3A
CD74HC374E	Active	Production	PDIP (N) 20	20 TUBE	Yes	NIPDAU NIPDAU	N/A for Pkg Type	-55 to 125	CD74HC374E
CD74HC374E.A	Active	Production	PDIP (N) 20	20 TUBE	Yes	NIPDAU	N/A for Pkg Type	-55 to 125	CD74HC374E
CD74HC374M	Obsolete	Production	SOIC (DW) 20	-	-	Call TI	Call TI	-55 to 125	HC374M
CD74HC374M96	Active	Production	SOIC (DW) 20	2000 LARGE T&R	Yes	NIPDAU	Level-1-260C-UNLIM	-55 to 125	HC374M
CD74HC374M96.A	Active	Production	SOIC (DW) 20	2000 LARGE T&R	Yes	NIPDAU	Level-1-260C-UNLIM	-55 to 125	HC374M
CD74HC374M96E4	Active	Production	SOIC (DW) 20	2000 LARGE T&R	Yes	NIPDAU	Level-1-260C-UNLIM	-55 to 125	HC374M
CD74HC574E	Active	Production	PDIP (N) 20	20 TUBE	Yes	NIPDAU	N/A for Pkg Type	-55 to 125	CD74HC574E
CD74HC574E.A	Active	Production	PDIP (N) 20	20 TUBE	Yes	NIPDAU	N/A for Pkg Type	-55 to 125	CD74HC574E
CD74HC574M	Obsolete	Production	SOIC (DW) 20	-	-	Call TI	Call TI	-55 to 125	HC574M
CD74HC574M.B	Obsolete	Production	SOIC (DW) 20	-	-	Call TI	Call TI	-55 to 125	HC574M
CD74HC574M96	Active	Production	SOIC (DW) 20	2000 LARGE T&R	Yes	NIPDAU	Level-1-260C-UNLIM	-55 to 125	HC574M

Orderable part number	Status (1)	Material type (2)	Package Pins	Package qty Carrier	RoHS (3)	Lead finish/ Ball material (4)	MSL rating/ Peak reflow (5)	Op temp (°C)	Part marking (6)
CD74HC574M96.A	Active	Production	SOIC (DW) 20	2000 LARGE T&R	Yes	NIPDAU	Level-1-260C-UNLIM	-55 to 125	HC574M
CD74HCT374E	Active	Production	PDIP (N) 20	20 TUBE	Yes	NIPDAU NIPDAU	N/A for Pkg Type	-55 to 125	CD74HCT374E
CD74HCT374E.A	Active	Production	PDIP (N) 20	20 TUBE	Yes	NIPDAU	N/A for Pkg Type	-55 to 125	CD74HCT374E
CD74HCT374EE4	Active	Production	PDIP (N) 20	20 TUBE	Yes	NIPDAU	N/A for Pkg Type	-55 to 125	CD74HCT374E
CD74HCT374M	Obsolete	Production	SOIC (DW) 20	-	-	Call TI	Call TI	-55 to 125	HCT374M
CD74HCT374M96	Active	Production	SOIC (DW) 20	2000 LARGE T&R	Yes	NIPDAU	Level-1-260C-UNLIM	-55 to 125	HCT374M
CD74HCT374M96.A	Active	Production	SOIC (DW) 20	2000 LARGE T&R	Yes	NIPDAU	Level-1-260C-UNLIM	-55 to 125	HCT374M
CD74HCT574E	Active	Production	PDIP (N) 20	20 TUBE	Yes	NIPDAU	N/A for Pkg Type	-55 to 125	CD74HCT574E
CD74HCT574E.A	Active	Production	PDIP (N) 20	20 TUBE	Yes	NIPDAU	N/A for Pkg Type	-55 to 125	CD74HCT574E
CD74HCT574M	Obsolete	Production	SOIC (DW) 20	-	-	Call TI	Call TI	-55 to 125	HCT574M
CD74HCT574M96	Active	Production	SOIC (DW) 20	2000 LARGE T&R	Yes	NIPDAU	Level-1-260C-UNLIM	-55 to 125	HCT574M
CD74HCT574M96.A	Active	Production	SOIC (DW) 20	2000 LARGE T&R	Yes	NIPDAU	Level-1-260C-UNLIM	-55 to 125	HCT574M
CD74HCT574PWR	Active	Production	TSSOP (PW) 20	2000 LARGE T&R	Yes	NIPDAU NIPDAU	Level-1-260C-UNLIM	-55 to 125	HK574
CD74HCT574PWR.A	Active	Production	TSSOP (PW) 20	2000 LARGE T&R	Yes	NIPDAU	Level-1-260C-UNLIM	-55 to 125	HK574

(1) **Status:** For more details on status, see our [product life cycle](#).

(2) **Material type:** When designated, preproduction parts are prototypes/experimental devices, and are not yet approved or released for full production. Testing and final process, including without limitation quality assurance, reliability performance testing, and/or process qualification, may not yet be complete, and this item is subject to further changes or possible discontinuation. If available for ordering, purchases will be subject to an additional waiver at checkout, and are intended for early internal evaluation purposes only. These items are sold without warranties of any kind.

(3) **RoHS values:** Yes, No, RoHS Exempt. See the [TI RoHS Statement](#) for additional information and value definition.

(4) **Lead finish/Ball material:** Parts may have multiple material finish options. Finish options are separated by a vertical ruled line. Lead finish/Ball material values may wrap to two lines if the finish value exceeds the maximum column width.

(5) **MSL rating/Peak reflow:** The moisture sensitivity level ratings and peak solder (reflow) temperatures. In the event that a part has multiple moisture sensitivity ratings, only the lowest level per JEDEC standards is shown. Refer to the shipping label for the actual reflow temperature that will be used to mount the part to the printed circuit board.

(6) **Part marking:** There may be an additional marking, which relates to the logo, the lot trace code information, or the environmental category of the part.

Multiple part markings will be inside parentheses. Only one part marking contained in parentheses and separated by a "-" will appear on a part. If a line is indented then it is a continuation of the previous line and the two combined represent the entire part marking for that device.

Important Information and Disclaimer: The information provided on this page represents TI's knowledge and belief as of the date that it is provided. TI bases its knowledge and belief on information provided by third parties, and makes no representation or warranty as to the accuracy of such information. Efforts are underway to better integrate information from third parties. TI has taken and continues to take reasonable steps to provide representative and accurate information but may not have conducted destructive testing or chemical analysis on incoming materials and chemicals. TI and TI suppliers consider certain information to be proprietary, and thus CAS numbers and other limited information may not be available for release.

In no event shall TI's liability arising out of such information exceed the total purchase price of the TI part(s) at issue in this document sold by TI to Customer on an annual basis.

OTHER QUALIFIED VERSIONS OF CD54HC374, CD54HC574, CD54HCT374, CD54HCT574, CD74HC374, CD74HC574, CD74HCT374, CD74HCT574 :

- Catalog : [CD74HC374](#), [CD74HC574](#), [CD74HCT374](#), [CD74HCT574](#)
- Automotive : [CD74HCT574-Q1](#), [CD74HCT574-Q1](#)
- Enhanced Product : [CD74HCT574-EP](#), [CD74HCT574-EP](#)
- Military : [CD54HC374](#), [CD54HC574](#), [CD54HCT374](#), [CD54HCT574](#)

NOTE: Qualified Version Definitions:

- Catalog - TI's standard catalog product
- Automotive - Q100 devices qualified for high-reliability automotive applications targeting zero defects
- Enhanced Product - Supports Defense, Aerospace and Medical Applications
- Military - QML certified for Military and Defense Applications

TAPE AND REEL INFORMATION

QUADRANT ASSIGNMENTS FOR PIN 1 ORIENTATION IN TAPE

*All dimensions are nominal

Device	Package Type	Package Drawing	Pins	SPQ	Reel Diameter (mm)	Reel Width W1 (mm)	A0 (mm)	B0 (mm)	K0 (mm)	P1 (mm)	W (mm)	Pin1 Quadrant
CD74HC374M96	SOIC	DW	20	2000	330.0	24.4	10.8	13.3	2.7	12.0	24.0	Q1
CD74HC574M96	SOIC	DW	20	2000	330.0	24.4	10.8	13.3	2.7	12.0	24.0	Q1
CD74HCT374M96	SOIC	DW	20	2000	330.0	24.4	10.8	13.3	2.7	12.0	24.0	Q1
CD74HCT574M96	SOIC	DW	20	2000	330.0	24.4	10.8	13.3	2.7	12.0	24.0	Q1
CD74HCT574PWR	TSSOP	PW	20	2000	330.0	16.4	6.95	7.0	1.4	8.0	16.0	Q1

TAPE AND REEL BOX DIMENSIONS

*All dimensions are nominal

Device	Package Type	Package Drawing	Pins	SPQ	Length (mm)	Width (mm)	Height (mm)
CD74HC374M96	SOIC	DW	20	2000	356.0	356.0	45.0
CD74HC574M96	SOIC	DW	20	2000	356.0	356.0	45.0
CD74HCT374M96	SOIC	DW	20	2000	356.0	356.0	45.0
CD74HCT574M96	SOIC	DW	20	2000	356.0	356.0	45.0
CD74HCT574PWR	TSSOP	PW	20	2000	353.0	353.0	32.0

TUBE

*All dimensions are nominal

Device	Package Name	Package Type	Pins	SPQ	L (mm)	W (mm)	T (μm)	B (mm)
CD74HC374E	N	PDIP	20	20	506	13.97	11230	4.32
CD74HC374E.A	N	PDIP	20	20	506	13.97	11230	4.32
CD74HC574E	N	PDIP	20	20	506	13.97	11230	4.32
CD74HC574E.A	N	PDIP	20	20	506	13.97	11230	4.32
CD74HCT374E	N	PDIP	20	20	506	13.97	11230	4.32
CD74HCT374E.A	N	PDIP	20	20	506	13.97	11230	4.32
CD74HCT374EE4	N	PDIP	20	20	506	13.97	11230	4.32
CD74HCT574E	N	PDIP	20	20	506	13.97	11230	4.32
CD74HCT574E.A	N	PDIP	20	20	506	13.97	11230	4.32

N (R-PDIP-T**)

PLASTIC DUAL-IN-LINE PACKAGE

16 PINS SHOWN



- NOTES:
- A. All linear dimensions are in inches (millimeters).
 - B. This drawing is subject to change without notice.
 - Falls within JEDEC MS-001, except 18 and 20 pin minimum body length (Dim A).
 - The 20 pin end lead shoulder width is a vendor option, either half or full width.

DW0020A



PACKAGE OUTLINE

SOIC - 2.65 mm max height

SOIC



NOTES:

1. All linear dimensions are in millimeters. Dimensions in parenthesis are for reference only. Dimensioning and tolerancing per ASME Y14.5M.
2. This drawing is subject to change without notice.
3. This dimension does not include mold flash, protrusions, or gate burrs. Mold flash, protrusions, or gate burrs shall not exceed 0.15 mm per side.
4. This dimension does not include interlead flash. Interlead flash shall not exceed 0.43 mm per side.
5. Reference JEDEC registration MS-013.

EXAMPLE BOARD LAYOUT

DW0020A

SOIC - 2.65 mm max height

SOIC



LAND PATTERN EXAMPLE
SCALE:6X



SOLDER MASK DETAILS

4220724/A 05/2016

NOTES: (continued)

- 6. Publication IPC-7351 may have alternate designs.
- 7. Solder mask tolerances between and around signal pads can vary based on board fabrication site.

EXAMPLE STENCIL DESIGN

DW0020A

SOIC - 2.65 mm max height

SOIC



SOLDER PASTE EXAMPLE
BASED ON 0.125 mm THICK STENCIL
SCALE:6X

4220724/A 05/2016

NOTES: (continued)

8. Laser cutting apertures with trapezoidal walls and rounded corners may offer better paste release. IPC-7525 may have alternate design recommendations.
9. Board assembly site may have different recommendations for stencil design.

PW0020A



PACKAGE OUTLINE

TSSOP - 1.2 mm max height

SMALL OUTLINE PACKAGE



4220206/A 02/2017

NOTES:

1. All linear dimensions are in millimeters. Any dimensions in parenthesis are for reference only. Dimensioning and tolerancing per ASME Y14.5M.
2. This drawing is subject to change without notice.
3. This dimension does not include mold flash, protrusions, or gate burrs. Mold flash, protrusions, or gate burrs shall not exceed 0.15 mm per side.
4. This dimension does not include interlead flash. Interlead flash shall not exceed 0.25 mm per side.
5. Reference JEDEC registration MO-153.

EXAMPLE BOARD LAYOUT

PW0020A

TSSOP - 1.2 mm max height

SMALL OUTLINE PACKAGE



LAND PATTERN EXAMPLE
EXPOSED METAL SHOWN
SCALE: 10X



SOLDER MASK DETAILS

4220206/A 02/2017

NOTES: (continued)

- 6. Publication IPC-7351 may have alternate designs.
- 7. Solder mask tolerances between and around signal pads can vary based on board fabrication site.

EXAMPLE STENCIL DESIGN

PW0020A

TSSOP - 1.2 mm max height

SMALL OUTLINE PACKAGE



SOLDER PASTE EXAMPLE
BASED ON 0.125 mm THICK STENCIL
SCALE: 10X

4220206/A 02/2017

NOTES: (continued)

8. Laser cutting apertures with trapezoidal walls and rounded corners may offer better paste release. IPC-7525 may have alternate design recommendations.
9. Board assembly site may have different recommendations for stencil design.

J (R-GDIP-T**)

14 LEADS SHOWN

CERAMIC DUAL IN-LINE PACKAGE



DIM \ PINS **	14	16	18	20
A	0.300 (7,62) BSC	0.300 (7,62) BSC	0.300 (7,62) BSC	0.300 (7,62) BSC
B MAX	0.785 (19,94)	.840 (21,34)	0.960 (24,38)	1.060 (26,92)
B MIN	—	—	—	—
C MAX	0.300 (7,62)	0.300 (7,62)	0.310 (7,87)	0.300 (7,62)
C MIN	0.245 (6,22)	0.245 (6,22)	0.220 (5,59)	0.245 (6,22)



4040083/F 03/03

- NOTES:
- A. All linear dimensions are in inches (millimeters).
 - B. This drawing is subject to change without notice.
 - C. This package is hermetically sealed with a ceramic lid using glass frit.
 - D. Index point is provided on cap for terminal identification only on press ceramic glass frit seal only.
 - E. Falls within MIL STD 1835 GDIP1-T14, GDIP1-T16, GDIP1-T18 and GDIP1-T20.

重要なお知らせと免責事項

テキサス・インスツルメンツは、技術データと信頼性データ(データシートを含みます)、設計リソース(リファレンス デザインを含みます)、アプリケーションや設計に関する各種アドバイス、Web ツール、安全性情報、その他のリソースを、欠陥が存在する可能性のある「現状のまま」提供しており、商品性および特定目的に対する適合性の黙示保証、第三者の知的財産権の非侵害保証を含むいかなる保証も、明示的または黙示的にかかわらず拒否します。

これらのリソースは、テキサス・インスツルメンツ製品を使用する設計の経験を積んだ開発者への提供を意図したものです。(1) お客様のアプリケーションに適したテキサス・インスツルメンツ製品の選定、(2) お客様のアプリケーションの設計、検証、試験、(3) お客様のアプリケーションに該当する各種規格や、その他のあらゆる安全性、セキュリティ、規制、または他の要件への確実な適合に関する責任を、お客様のみが単独で負うものとし、ます。

上記の各種リソースは、予告なく変更される可能性があります。これらのリソースは、リソースで説明されているテキサス・インスツルメンツ製品を使用するアプリケーションの開発の目的でのみ、テキサス・インスツルメンツはその使用をお客様に許諾します。これらのリソースに関して、他の目的で複製することや掲載することは禁止されています。テキサス・インスツルメンツや第三者の知的財産権のライセンスが付与されている訳ではありません。お客様は、これらのリソースを自身で使用した結果発生するあらゆる申し立て、損害、費用、損失、責任について、テキサス・インスツルメンツおよびその代理人を完全に補償するものとし、テキサス・インスツルメンツは一切の責任を拒否します。

テキサス・インスツルメンツの製品は、[テキサス・インスツルメンツの販売条件](#)、または [ti.com](https://www.ti.com) やかかるテキサス・インスツルメンツ製品の関連資料などのいずれかを通じて提供する適用可能な条項の下で提供されています。テキサス・インスツルメンツがこれらのリソースを提供することは、適用されるテキサス・インスツルメンツの保証または他の保証の放棄の拡大や変更を意味するものではありません。

お客様がいかなる追加条項または代替条項を提案した場合でも、テキサス・インスツルメンツはそれらに異議を唱え、拒否します。

郵送先住所：Texas Instruments, Post Office Box 655303, Dallas, Texas 75265
Copyright © 2025, Texas Instruments Incorporated