

FPC402 クワッド・ポート・コントローラ

1 特長

- 4つのポートにわたる制御信号管理と I2C 集約
- 複数の FPC402 を組み合わせることにより、合計 56 のポートを単一のホスト・インターフェイスから制御可能
- 独立した I2C マルチプレクサ、LED ドライバ、ピン数の多い FPGA/CPLD 制御デバイスが不要
- すべての低速制御信号をポートの近くで処理するため、PCB の配線の複雑性を低減
- I2C (最高 1MHz) または SPI (最高 10MHz) のホスト制御インターフェイスを選択可能
- 重要なユーザー指定のデータをモジュールから自動的にプリフェッチ
- ブロードキャスト・モードにより、すべての FPC402 コントローラ間にわたってすべてのポートへ同時に書き込み可能
- 先進の LED 機能によるポート・ステータスの表示、点滅や調光もプログラム可能
- 割り込みイベントをカスタマイズ可能
- 独立したホスト側 I/O 電圧: 1.8V ~ 3.3V
- 小型の WQFN パッケージにより、PCB の裏側でポートの下に配置可能

2 アプリケーション

- ToR / 集約 / コア・スイッチおよびルータ
- ワイヤレス・インフラストラクチャのベースバンド・ユニットおよびリモート・ラジオ・ユニット
- ビデオ・スイッチおよびルータ
- ストレージ・カードおよびストレージ・ラック
- SFP、QSFP、QSFP-DD、OSFP、Mini-SAS HD ポートの管理

3 概要

FPC402 クワッド・ポート・コントローラは、SFP、QSFP、Mini-SAS HD など一般的なポート・タイプ用の低速信号アグリゲータとして機能します。FPC402 は 4 つのポートの低速制御信号および I2C 信号をすべて集約し、使いやすい単一の管理インターフェイスをホストに提供します (I2C または SPI)。複数の FPC402 を使用すると、ホストに対する 1 つの共通の制御インターフェイスを備えたポート数の多いアプリケーションが実現できます。FPC402 は PCB の裏側でプレスフィット・コネクタの下に配置できるように設計されているため、配線が簡単に行えます。ポートの低速信号を、この局所化された方法で制御することにより、IO 数の少ない制御デバイス (FPGA、CPLD、MCU) を使用でき、配線レイヤの密度が低減されるため、システムの BOM コストを削減できます。

製品情報⁽¹⁾

部品番号	パッケージ	本体サイズ (公称)
FPC402	WQFN (56)	5.00mm × 11.00mm

(1) 利用可能なすべてのパッケージについては、このデータシート末尾にある注文情報を参照してください。

デバイスの比較

部品番号	アクセス可能な下流アドレス	ピン互換
FPC402	すべての有効な I2C アドレス	○
FPC401	MSA アドレス: 0xA0, 0xA2	○

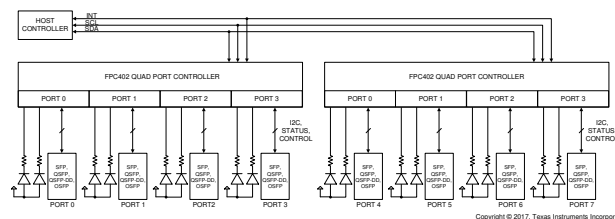

ブロック概略図



Table of Contents

1 特長	1	8.4 Device Functional Modes.....	22
2 アプリケーション	1	8.5 Programming.....	28
3 概要	1	9 Application and Implementation	29
4 Revision History	2	9.1 Application Information.....	29
5 概要 (続き)	3	9.2 Typical Application.....	29
6 Pin Configuration and Functions	4	10 Power Supply Recommendations	34
Pin Functions.....	4	10.1 Power Supply Sequencing.....	34
7 Specifications	7	11 Layout	35
7.1 Absolute Maximum Ratings.....	7	11.1 Layout Guidelines.....	35
7.2 ESD Ratings.....	7	11.2 Layout Example.....	36
7.3 Recommended Operating Conditions.....	7	11.3 Recommended Package Footprint.....	37
7.4 Thermal Information.....	8	12 Device and Documentation Support	38
7.5 Electrical Characteristics.....	8	12.1 Documentation Support.....	38
7.6 Timing Requirements.....	10	12.2 ドキュメントの更新通知を受け取る方法.....	38
7.7 Switching Characteristics.....	11	12.3 サポート・リソース.....	38
7.8 Typical Characteristics.....	12	12.4 Trademarks.....	38
8 Detailed Description	13	12.5 静電気放電に関する注意事項.....	38
8.1 Overview.....	13	12.6 用語集.....	38
8.2 Functional Block Diagram.....	13	13 Mechanical, Packaging, and Orderable Information	38
8.3 Feature Description.....	14		

4 Revision History

Changes from Revision B (August 2018) to Revision C (September 2020)	Page
• 完全な量産データのデータシートを ti.com にリリース.....	1
• 文書全体にわたって表、図、相互参照の採番方法を更新.....	1
• Added the recommended foot print for RHU package.....	37
Changes from Revision A (October 2017) to Revision B (August 2018)	Page
• Changed MOD_SDA[0] pin number from: 16 to: 35	4
• Changed MOD_SDA[1] pin number from: 5 to: 48.....	4
• Changed MOD_SDA[2] pin number from: 48 to: 5.....	4
• Changed MOD_SDA[3] pin number from: 35 to: 16.....	4
Changes from Revision * (June 2017) to Revision A (October 2017)	Page
• 事前情報を量産データに変更.....	1
• Updated T _{POR} (max)	10

5 概要 (続き)

FPC402 は標準の SFF-8431、SFF-8436、SFF-8449 低速管理インターフェイスと互換性があり、各ポートに専用の 100/400kHz I2C インターフェイスが搭載されています。ポート・ステータス LED の駆動や電源スイッチの制御などの機能を実行するため、追加の汎用ピンも利用可能です。LED ドライバは、点滅や調光のプログラムなどの便利な機能を備えています。ホスト・コントローラへのインターフェイスは、低電圧の I/O をサポートするために 1.8V~3.3V の独立電源で動作できます。

FPC402 は各モジュールでユーザーが指定したレジスタからデータをプリフェッチできるため、ホストは高速な I2C (最高 1MHz) または SPI (最高 10MHz) インターフェイスでデータへすぐにアクセスできます。さらに、FPC402 は制御下のポートのいずれかに関連する重要な、ユーザー構成可能なイベントが発生した場合、ホストへの割り込みをトリガできます。このため、モジュールを継続的にポーリングする必要はありません。

6 Pin Configuration and Functions



图 6-1. RHU Package 56-Pin QFN Top View

Pin Functions

PIN		I/O	DESCRIPTION
NAME	NO.		
CAPL	32	O	Connect a single 2.2- μ F capacitor to GND.

PIN		I/O	DESCRIPTION
NAME	NO.		
CTRL1	23	I/O	Host-side control interface. These pins are used to implement I2C or SPI depending on the PROTOCOL_SEL pin configuration.
CTRL2	24	I/O	
CTRL3	28	I, Weak internal pullup	I2C mode (PROTOCOL_SEL = Float or High): CTRL1: SCL – I2C Clock input / open-drain output
CTRL4	21	O	CTRL2: SDA – I2C Data input / open-drain output
			CTRL3: SET_ADDR_N – input, address assignment enable. Also used to receive external LED clock. CTRL4: ADDR_DONE_N – output, address assignment complete. Also used to transmit LED clock.
EN	22	I, Weak internal pullup	SPI mode (PROTOCOL_SEL = GND): CTRL1: SCK – Serial clock input CTRL2: SS_N – Active-low slave select input CTRL3: MOSI – Master output or slave input CTRL4: MISO – Master input or slave output
GPIO[0]	42	I/O	Device enable. When EN = 0, the FPC402 is in a power-down state and does not respond to the host-side control bus, nor does it perform port-side I2C accesses. When EN=VDD2 or Float, the FPC402 is fully enabled and will respond to the host-side control bus provided VDD1 and VDD2 power has been stable for at least T _{POr} . V _{IH} for this pin is referenced to VDD2. The minimum required assert and deassert time is 12.5 μs.
GPIO[1]	53		
GPIO[2]	8		
GPIO[3]	19		
GND	27, DAP	Power	General-purpose I/O. Output high voltage (V _{OH}) and input high voltage (V _{IH}) are based on VDD1. Configured as input (high-Z) by default.
HOST_INT_N	25	O, Open-Drain	Ground reference. The GND pins must be connected through a low-resistance path to the board GND plane.
IN_A[0]	41	I, Weak internal pullup	Open-drain 3.3-V tolerant active-low interrupt output. It asserts low to interrupt the host. The events which trigger an interrupt are programmable through registers. This pin can be connected in a wired-OR fashion with other FPC402s' interrupt pins. A single pullup resistor to VDD1 or VDD2 in the 2-kΩ to 5-kΩ range is adequate for the entire net.
IN_A[1]	50		
IN_A[2]	55		
IN_A[3]	10		
IN_B[0]	39	I, Weak internal pullup	Low-speed port status input A. Example usage: SFP: Mod_ABS[3:0] QSFP: ModPrsL[3:0]
IN_B[1]	47		
IN_B[2]	1		
IN_B[3]	12		
IN_C[0]	37	I, Weak internal pullup	Low-speed port status input B. Example usage: SFP: Tx_Fault[3:0] QSFP: IntL[3:0]
IN_C[1]	46		
IN_C[2]	3		
IN_C[3]	14		
			Low-speed port status input C. Example usage: SFP: Rx_LOS[3:0] QSFP: N/A

PIN		I/O	DESCRIPTION
NAME	NO.		
MOD_SCL[0]	36	I/O, Open- Drain	I2C clock open-drain output to the module. External 2-kΩ to 5-kΩ pullup resistor is required. This pin is 3.3-V LVCMOS tolerant.
MOD_SCL[1]	49		
MOD_SCL[2]	4		
MOD_SCL[3]	15		
MOD_SDA[0]	35	I/O, Open- Drain	I2C data input or open-drain output to the module. External 2-kΩ to 5-kΩ pullup resistor is required. This pin is 3.3-V LVCMOS tolerant.
MOD_SDA[1]	48		
MOD_SDA[2]	5		
MOD_SDA[3]	16		
OUT_A[0]	40	O	Low-speed port control output A. OUT_A is disabled by default (high-Z) and when enabled drives high logic unless reprogrammed. A 10-kΩ pullup or pulldown resistor is recommended to set a default logic value before this output is enabled. See セクション 8.3.3 for more details. Example usage: SFP: Tx_Disable[3:0] QSFP: ResetL[3:0]
OUT_A[1]	44		
OUT_A[2]	56		
OUT_A[3]	11		
OUT_B[0]	38	O	Low-speed port control output B. Output is disabled by default (high-Z) and when enabled drives low logic unless reprogrammed. A 10-kΩ pullup or pulldown resistor is recommended to set a default logic value before this output is enabled. See セクション 8.3.3 for more details. Example usage: SFP: RS[3:0] QSFP: LPMODE[3:0]
OUT_B[1]	45		
OUT_B[2]	2		
OUT_B[3]	13		
OUT_C[0]	34	O	Low-speed port control output C. Can be used to drive port status LED. Special LED driving features are available on this output. This output is enabled and high logic by default at power up. See セクション 8.3.2 for more details. Example usage: SFP: LED_GRN[3:0] QSFP: LED_GRN[3:0] This pin requires a series resistor with a value of at least 33 Ω. The LED current-limiting resistor can serve for this purpose.
OUT_C[1]	51		
OUT_C[2]	6		
OUT_C[3]	17		
OUT_D[0]	33	O	Low-speed port control output D. Can be used to drive port status LED. Special LED driving features are available on this output. This output is enabled and high logic by default at power up. See セクション 8.3.2 for more details. Example usage: SFP: LED_YLW[3:0] QSFP: N/A This pin requires a series resistor with a value of at least 33 Ω. The LED current-limiting resistor can serve for this purpose.
OUT_D[1]	52		
OUT_D[2]	7		
OUT_D[3]	18		
PROTOCOL_SEL	31	I, Weak internal pullup	Used to select between I2C and SPI host-side control interface. Float or High: Inter-IC Control (I2C) GND: Serial Peripheral Interface (SPI)
SPI_LED_SYNC	30	I/O	LED clock synchronization pin for SPI mode only. When using SPI as the host-side control interface (PROTOCOL_SEL=GND), connect all FPC402 SPI_LED_CLK pins together. This ensures LED synchronization across all FPC402 devices. When using I2C as the host-side control interface, this pin can be floating. LED synchronization is ensured by other means in I2C mode.

PIN		I/O	DESCRIPTION
NAME	NO.		
TEST_N	29	I, Weak internal pullup	TI test mode. Float or High: Normal operation GND: TI Test Mode
VDD1	9, 43, 54	Power	Main power supply, VDD1 = 3.3 V ± 5%. TI recommends connecting at least one 1-μF and one 0.1-μF decoupling capacitors per VDD1 pin as close to the pin as possible.
VDD2	20, 26	Power	Power supply for host-side interface I/Os (CTRL[4:1]). VDD2 can be 1.8 V to 3.3 V ± 5%. If the host-side interface operates at 3.3 V, then VDD1 and VDD2 can be connected to the same 3.3-V ± 5% supply. TI recommends connecting at least one 1-μF and one 0.1-μF decoupling capacitors per VDD2 pin as close to the pin as possible.

7 Specifications

7.1 Absolute Maximum Ratings

over operating free-air temperature range (unless otherwise noted)⁽¹⁾

		MIN	MAX	UNIT
VDD1 _{ABSMAX}	Supply voltage (VDD1)	-0.5	5	V
VDD2 _{ABSMAX}	Supply voltage (VDD2)	-0.5	5	V
VIO _{VDD1,ABSMAX}	3.3-V LVCMOS I/O voltage (all pins except CTRL[4:1])	-0.5	5	V
VIO _{VDD2,ABSMAX}	VDD2 LVCMOS I/O voltage (CTRL[4:1] pins only)	-0.5	5	V
T _{J,ABSMAX}	Junction temperature		150	°C
T _{stg}	Storage temperature	-65	150	°C

- (1) Stresses beyond those listed under *Absolute Maximum Ratings* may cause permanent damage to the device. These are stress ratings only, which do not imply functional operation of the device at these or any other conditions beyond those indicated under *Recommended Operating Conditions*. Exposure to absolute-maximum-rated conditions for extended periods may affect device reliability.

7.2 ESD Ratings

		VALUE	UNIT
V _(ESD)	Electrostatic discharge	Human-body model (HBM), per ANSI/ESDA/JEDEC JS-001 ⁽¹⁾	V
		Charged-device model (CDM), per JEDEC specification JESD22-C101 ⁽²⁾	

- (1) JEDEC document JEP155 states that 500-V HBM allows safe manufacturing with a standard ESD control process.
(2) JEDEC document JEP157 states that 250-V CDM allows safe manufacturing with a standard ESD control process.

7.3 Recommended Operating Conditions

Over operating free-air temperature range (unless otherwise noted).

		MIN	NOM	MAX	UNIT
VDD1	Supply voltage, VDD1 to GND. DC plus AC power should not exceed these limits.	3.135	3.3	3.465	V
VDD2	Host-side interface supply voltage, VDD2 to GND. 1.8 to 3.3 V typical. DC plus AC power should not exceed these limits.	1.71	1.8, 2.5, 3.3	3.465	V
t _{Ramp-VDD1}	VDD1 supply ramp time, from 0 V to 3.135 V	1			ms
t _{Ramp-VDD2}	VDD2 supply ramp time, from 0 V to VDD2 – 5%	1			ms
T _A	Operating ambient temperature	-40		85	°C
T _J	Operating junction temperature	-40		125	°C

7.4 Thermal Information

THERMAL METRIC ⁽¹⁾		FPC402	UNIT
		RHU (WQFN)	
		56 PINS	
R _{θJA}	Junction-to-ambient thermal resistance	30.1	°C/W
R _{θJC(top)}	Junction-to-case (top) thermal resistance	13.3	°C/W
R _{θJB}	Junction-to-board thermal resistance	6.5	°C/W
ψ _{JT}	Junction-to-top characterization parameter	0.3	°C/W
ψ _{JB}	Junction-to-board characterization parameter	6.4	°C/W
R _{θJC(bot)}	Junction-to-case (bottom) thermal resistance	2.0	°C/W

(1) For more information about traditional and new thermal metrics, see the [Semiconductor and IC Package Thermal Metrics](#) application report.

7.5 Electrical Characteristics

T_J = –40°C to 125°C, VDD1 = 3.3 V ± 5%, VDD2 = 3.3 V ± 5% (unless otherwise noted).

PARAMETER		TEST CONDITIONS	MIN	TYP	MAX	UNIT
POWER SUPPLY						
W _{TOTAL}	Total device power dissipation	VDD1 = VDD2 = 3.3 V, Outputs sourcing maximum current, OUT_C and OUT_D are OFF (V _{out} = High)		90	110	mW
		VDD1 = 3.3 V, VDD2 = 2.5 V, Outputs sourcing maximum current, OUT_C and OUT_D are OFF (V _{out} = High)		100	110	
		VDD1 = 3.3 V, VDD2 = 1.8 V, Outputs sourcing maximum current, OUT_C and OUT_D are OFF (V _{out} = High)		100	120	
I _{VDD1}	Current consumption for VDD1 supply	VDD1 = VDD2 = 3.3 V, OUT_C and OUT_D are OFF (V _{out} = High)		26	31	mA
		VDD1 = VDD2 = 2.5 V, OUT_C and OUT_D are OFF (V _{out} = High)		27	32	
		VDD1 = 3.3 V, VDD2 = 1.8 V, OUT_C and OUT_D are OFF (V _{out} = High)		29	34	
I _{VDD2}	Current consumption for VDD2 supply	VDD1 = VDD2 = 3.3 V, Outputs sourcing maximum current, OUT_C and OUT_D are OFF (V _{out} = High)		0.2	0.35	mA
		VDD1 = 3.3 V, VDD2 = 2.5 V, Outputs sourcing maximum current, OUT_C and OUT_D are OFF (V _{out} = High)		0.1	0.3	
		VDD1 = 3.3 V, VDD2 = 1.8 V, Outputs sourcing maximum current, OUT_C and OUT_D are OFF (V _{out} = High)		0.1	0.25	
I _{total-idle}	Total device supply current consumption in idle mode				6.5	mA
LVC MOS I/O DC SPECIFICATIONS						
V _{IH}	High level input voltage	Applies to IN_A, IN_B, IN_C, PROTOCOL_SEL, and GPIO[3:0]	2		3.465	V
		Applies to EN	0.7 × VDD2		VDD2	

$T_J = -40^{\circ}\text{C}$ to 125°C , $V_{DD1} = 3.3\text{ V} \pm 5\%$, $V_{DD2} = 3.3\text{ V} \pm 5\%$ (unless otherwise noted).

PARAMETER		TEST CONDITIONS	MIN	TYP	MAX	UNIT
V_{IL}	Low level input voltage	Applies to IN_A, IN_B, IN_C, PROTOCOL_SEL, GPIO[3:0], and EN	-0.3		0.8	V
V_{OH}	High level output voltage	Applies to OUT_A, OUT_B, and GPIO[3:0], $I_{OH} = -2\text{ mA}$	2.8		3.465	V
		Applies to OUT_C and OUT_D, $I_{OH} = -50\text{ }\mu\text{A}$	2.5			
V_{OL}	Low level output voltage	Applies to OUT_A, OUT_B, and GPIO[3:0], $I_{OL} = 2\text{ mA}$	GND		0.4	V
		Applies to OUT_C and OUT_D, $I_{OL} = 18\text{ mA}$	GND		0.4	
I_{IH}	High level input current	Applies to IN_A, IN_B, IN_C, and GPIO[3:0]	-1		1	μA
I_{IL}	Low level input current	Applies to IN_A, IN_B, IN_C	-220		-170	μA
		Applies to GPIO[3:0]	-1		1	
t_{SP-LS}	Pulse width of spikes that are suppressed by FPC402 input de-glitch filter on all IN_* low-speed pins	Pulses shorter than min are suppressed, and pulses longer than the max are not suppressed.	30		50	μs
DOWNSTREAM MASTER I2C ELECTRICAL CHARACTERISTICS (MOD_SCL AND MOD_SDA)						
V_{OL}	Low level output voltage	$I_{OL} = 3\text{ mA}$	GND		0.4	V
V_{IL}	Low level input voltage		-0.3		1.04	V
V_{IH}	High level input voltage		2.19		3.465	V
$C_b^{(1)}$	I2C bus capacitive load	1.6 k Ω pull-up resistor max			200	pF
HOST-SIDE I2C ELECTRICAL CHARACTERISTICS (PROTOCOL_SEL = FLOAT/HIGH)						
V_{IH}	Input high level voltage	SDA (CTRL2) and SCL (CTRL1)	$0.7 \times V_{DD2}$		V_{DD2}	V
V_{IL}	Input low level voltage	SDA (CTRL2) and SCL (CTRL1)			$0.3 \times V_{DD2}$	V
$C_{IN}^{(1)}$	Input pin capacitance	SDA (CTRL2) and SCL (CTRL1)		0.5	1	pF
V_{OL}	Low level output voltage	SDA (CTRL2) or SCL (CTRL1), $I_{OL} = 3\text{ mA}$	GND		0.4	V
I_L	IL Leakage current	SDA (CTRL2) or SCL (CTRL1), $V_{IN} = V_{DD2}$	-1		1	μA
$C_b^{(1)}$	I2C bus capacitive load				550	pF
HOST-SIDE SPI ELECTRICAL CHARACTERISTICS (PROTOCOL_SEL = GND)						
V_{IH}	Input high level voltage	SCK (CTRL1), SS_N (CTRL2), and MOSI (CTRL3)	$0.7 \times V_{DD2}$			V
V_{IL}	Input low level voltage	SCK (CTRL1), SS_N (CTRL2), and MOSI (CTRL3)			$0.3 \times V_{DD2}$	V
$C_{IN}^{(1)}$	Input pin capacitance	SCK (CTRL1), SS_N (CTRL2), and MOSI (CTRL3)		0.5	1	pF
V_{OH}	High level output voltage	MISO (CTRL4) pin, $I_{OH} = -4\text{ mA}$	$0.7 \times V_{DD2}$			V
V_{OL}	Low level output voltage	MISO (CTRL4) pin, $I_{OL} = 4\text{ mA}$	GND		0.4	V
I_L	Leakage current	MOSI (CTRL3)	-220		-170	μA
		SCK (CTRL1), SS_N (CTRL2), and MISO (CTRL4)	-1		1	
$C_{MISO}^{(1)}$	MISO output capacitive load	MISO (CTRL4) pin			50	pF

(1) These parameters are not production tested.

7.6 Timing Requirements

		MIN	NOM	MAX	UNIT	
GENERAL TIMING REQUIREMENTS						
t_{POR}	Internal power-on reset (PoR) time	Time between stable VDD1 power supply ($VDD1 \geq 3.3V - 5\%$) and de-assertion of internal PoR. The port-side and host-side control interfaces (I2C and/or SPI) are not operational during this time.		30	60	ms
HOST-SIDE SPI TIMING REQUIREMENTS (PROTOCOL_SEL = GND) ^{(1) (2)}						
f_{SPI}		0.1		10	MHz	
t_{HI-SCK}		$0.4 + f_{SPI}$			ns	
t_{LO-SCK}		$0.4 + f_{SPI}$			ns	
$t_{HD-MOSI}$		1			ns	
$t_{SU-MOSI}$		1			ns	
t_{HD-SSN}		4			ns	
t_{SU-SSN}		1.2			ns	
$t_{OFF-SSN}$		For writes and local FPC402 register reads	1		μs	
		For consecutive downstream (remote) register reads on the same port, assuming 400-KHz I2C	170			
		For consecutive downstream (remote) register reads on the same port, assuming 100-KHz I2C	620			
$t_{ODZ-MISO}$	MISO (CTRL4) driven-to-TRI_STATE time	32			ns	
$t_{OZD-MISO}$	MISO (CTRL4) TRI_STATE-to-driven time	10			ns	
t_{OD}	MISO (CTRL4) output delay time	15			ns	
HOST-SIDE I2C TIMING REQUIREMENTS (PROTOCOL_SEL = FLOAT OR HIGH) ^{(2) (3) (4)}						
f_{SCL}	Host-side I2C clock frequency (CTRL1) in I2C mode	100		1000	kHz	
t_{BUF}	Bus free time between STOP and START condition	0.5			μs	
t_{HD-STA}	Hold time after (repeated) START condition. After this period, the first clock is generated.	0.3			μs	
t_{SU-STA}	Repeated START condition setup time	0.3			μs	
t_{SU-STO}	STOP condition setup time	0.3			μs	
t_{HD-DAT}	SDA (CTRL2) hold time	32			ns	
t_{SU-DAT}	SDA (CTRL2) setup time	Applies to standard-mode I2C, 100 kHz	250		ns	
		Applies to fast-mode I2C, 400 kHz	100		ns	
		Applies to fast-mode plus I2C, 1000 kHz	50		ns	
t_{LOW}	SCL (CTRL1) clock low time	0.5			μs	
t_{HIGH}	SCL (CTRL1) clock high time	0.3			μs	

			MIN	NOM	MAX	UNIT
t _R	SDA (CTRL2) rise time, read	Applies to standard-mode I2C, 100 kHz			1000	ns
		Applies to fast-mode I2C, 400 kHz	20		300	ns
		Applies to fast-mode plus I2C, 1000 kHz			120	ns
t _F	SDA (CTRL2) fall time, read	Applies to standard-mode I2C, 100 kHz			300	ns
		Applies to fast-mode I2C, 400 kHz	4.4		300	ns
		Applies to fast-mode plus I2C, 1000 kHz	4.4		120	ns

- (1) SPI operation is available T_{POR} milliseconds after VDD1 power up, provided EN = high or float and VDD2 is stable.
- (2) These parameters are not production tested.
- (3) I2C operation is available T_{POR} milliseconds after VDD1 power up, provided EN = high or float and VDD2 is stable.
- (4) These specifications support I2C Rev 6 specifications

7.7 Switching Characteristics

over operating free-air temperature range (unless otherwise noted)

			MIN	TYP	MAX	UNIT
DOWNSTREAM MASTER I2C SWITCHING CHARACTERISTICS						
f _{SCL}	SCL clock frequency	Applies to standard-mode I2C, 100 kHz	66	83	100	kHz
		Applies to fast-mode I2C, 400 kHz	264	332	400	
t _{LOW-SCL}	SCL clock pulse width low period		1.3			μs
t _{HIGH-SCL}	SCL clock pulse width high period		0.6			μs
t _{BUF}	Time bus free before new transmission starts	Between STOP and START and between ACK and RESTART	20			μs
t _{HD-STA}	Hold time START operation		0.6			μs
t _{SU-STA}	Setup time START operation		0.6			μs
t _{HD-DAT}	Data hold time		0			μs
t _{SU-DAT}	Data setup time		0			μs
t _R	SCL and SDA rise time	100-KHz operation. From V _{IL} (Max) – 0.15 V to V _{IH} (Min) + 0.15 V.			300	ns
		100-KHz operation. From V _{IL} (Max) – 0.15 V to V _{IH} (Min) + 0.15 V.			300	
t _F	SCL and SDA fall time	100-KHz operation. From V _{IH} (Min) + 0.15 V to V _{IL} (Max) – 0.15 V.			300	ns
		400-KHz operation. From V _{IH} (Min) + 0.15 V to V _{IL} (Max) – 0.15 V.			300	
t _{SU-STO}	STOP condition setup time		0.6			μs
t _{SP-I2C} ⁽¹⁾	Pulse width of spikes that are suppressed by FPC402 input filter		0		50	ns

- (1) These parameters are not production tested.

7.8 Typical Characteristics

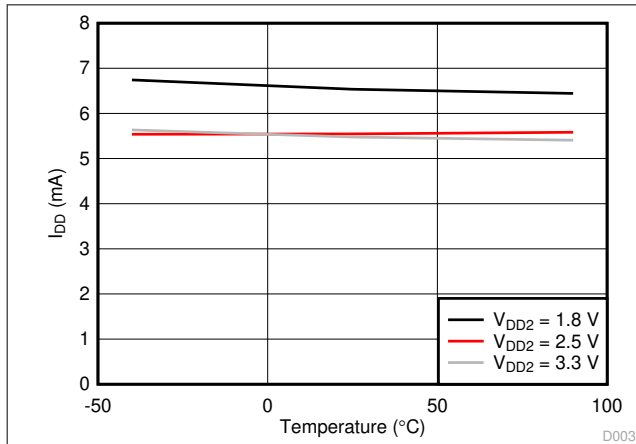

7-1. Static IDD1 vs. Ambient Temperature

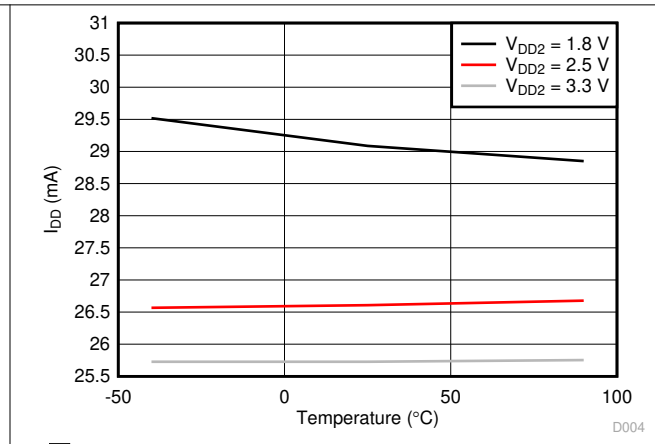

7-2. Dynamic IDD1 vs. Ambient Temperature

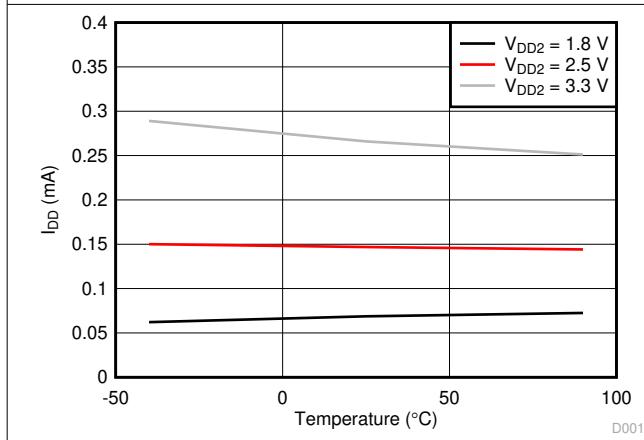

7-3. Static IDD2 vs. Ambient Temperature

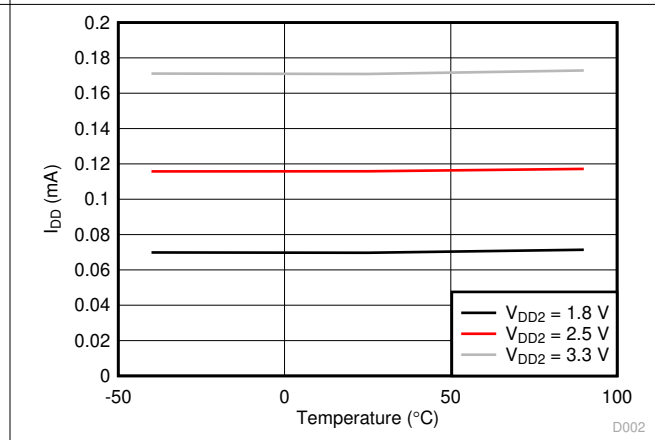

7-4. Dynamic IDD2 vs. Ambient Temperature

8 Detailed Description

8.1 Overview

The FPC402 is designed to interface with four ports and aggregate the I2C and low-speed control and status signals associated with these ports into a single host-side interface (I2C or SPI). Multiple FPC402s can be combined to support up to 56 total ports, all of which are controlled via the same host-side interface. This greatly reduces the number of signals which route to the host controller, saving valuable I/O resources, board routing space, and bill of materials (BOM) cost.

Functionally, the FPC402 is organized as shown in [セクション 8.2](#). Two types of host-side control interfaces are supported (I2C and SPI) for controlling and monitoring the downstream ports. The FPC402 has two special outputs per downstream port (OUT_C and OUT_D) which can be used to drive port status LEDs.

8.2 Functional Block Diagram

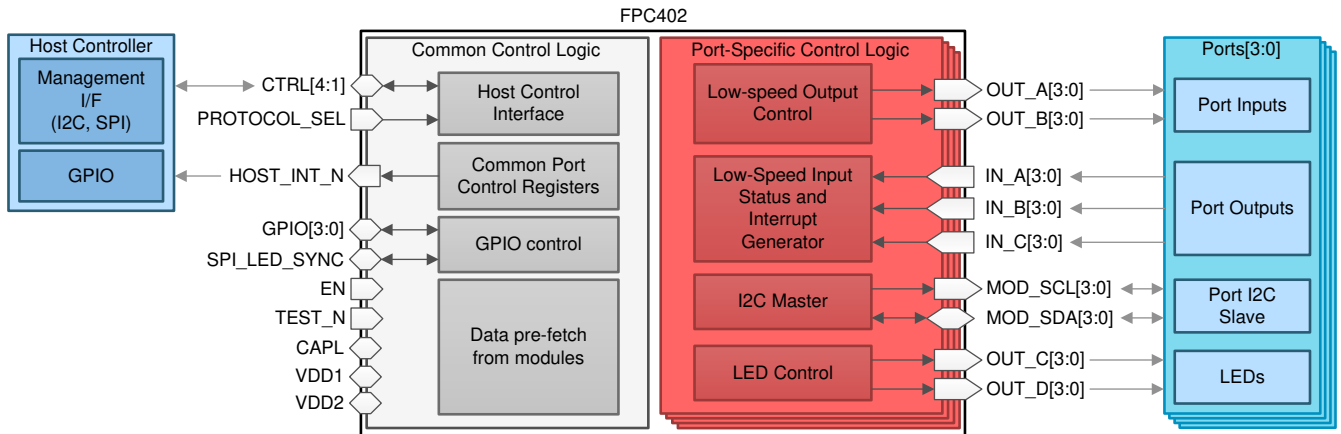

Copyright © 2017, Texas Instruments Incorporated

8.3 Feature Description

The features of the FPC402 quad port controller include:

- [Host-Side Control Interface](#)
- [LED Control](#)
- [Low-Speed Output Signal Control](#)
- [Low-Speed Input Status and Interrupt Generation](#)
- [Downstream \(Port-Side\) I2C Master](#)
- [Data Prefetch From Modules](#)
- [Scheduled Write](#)
- [Protocol Timeouts](#)
- [General-Purpose Inputs and Outputs](#)
- [Hot-Plug Support](#)

8.3.1 Host-Side Control Interface

The FPC402 has a single host-side interface which can be configured as one of two available protocols, depending on the pin strap value of the PROTOCOL_SEL pin:

- Inter-Integrated Circuit (I2C) up to 1-MHz Fast-mode Plus
- Serial Peripheral Interface (SPI) up to 10 MHz

These represent the two functional modes of operation for which the FPC402 can be configured. Refer to [セクション 8.4](#) for more details.

8.3.2 LED Control

The FPC402 uses two sets of outputs, OUT_C[3:0] and OUT_D[3:0], to drive LEDs associated with the ports under its control. Most SFP and QSFP applications use one yellow and one green LED per port to indicate different link status such as link up, link down, and other link states.

LEDs must be connected to the FPC402 in an active-low fashion as shown in [図 8-1](#) below. When the OUT_C or OUT_D pin drives a low voltage (V_{OL}), the LED is illuminated. When the OUT_C or OUT_D pin drives a high voltage (V_{OH}), the LED is off. Bi-color LEDs can be connected in a similar fashion, and each LED must have its own current-limiting resistor. The current-limiting resistor value is selected by choosing the desired maximum current through the LED and the corresponding voltage drop from the LED's current vs. voltage plot. The sum of forward voltage drop of the LED, the voltage drop across the series resistor, and the maximum V_{OL} (0.5-V maximum for currents between 2 and 18 mA) is equal to the LED supply voltage. Note that OUT_C and OUT_D are tri-stated while the device is held in reset (during POR or while the EN pin is low), and are enabled during normal operation and drive a high voltage by default.

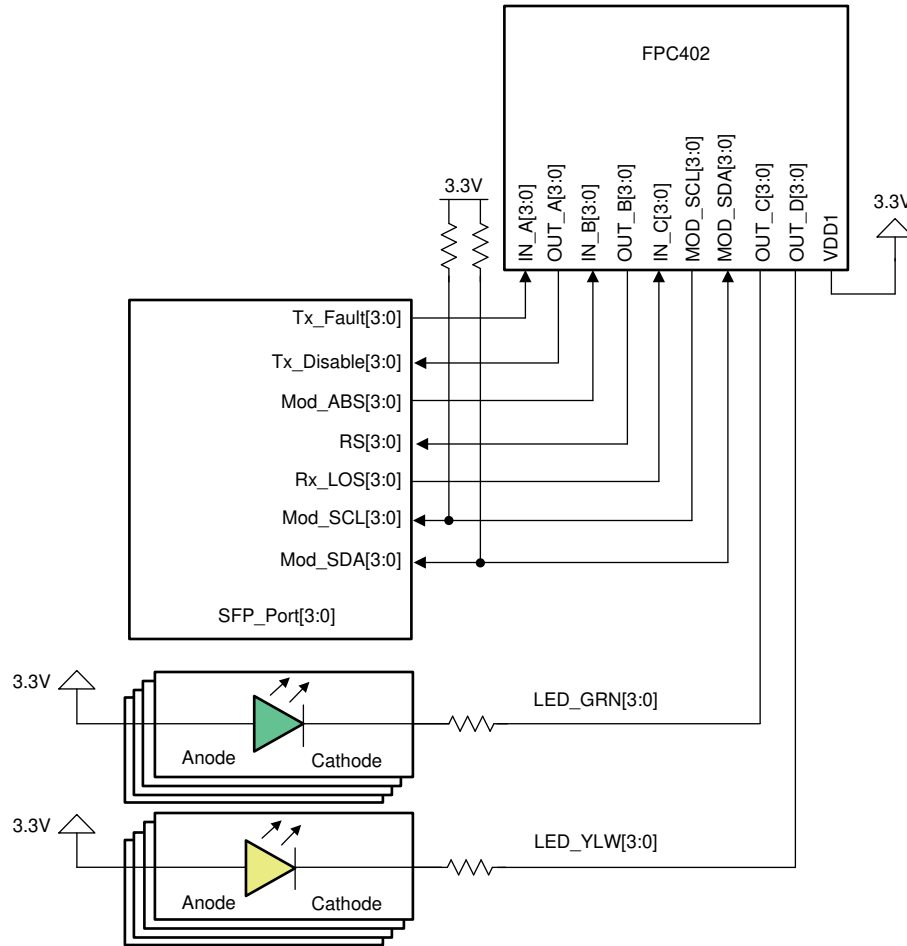

Copyright © 2017, Texas Instruments Incorporated

8-1. Example Connection Between OUT_C/OUT_D and Active-Low LEDs

Each port controlled by the FPC402 has a set of registers that allow the user to configure each LED into one of the following states:

- ON
- OFF
- PWM (ON with programmable intensity)
- BLINK (with programmable blink duty cycle, frequency, and ON intensity)

LED blinking is configured by setting an on and an off time. Each of these times is configured separately and have a minimum value of 2.5 ms and a maximum value of 637.5 ms for a maximum blinking period of 1.275 seconds. The pulse width modulation (PWM) duty cycle has 256 settings where 0 is completely off, and 255 is maximum brightness. Note that the PWM is 0 by default and must be configured for the LEDs to be visible in BLINK or PWM modes.

LED blinking can be synchronized across all four ports controlled by the FPC402, and the blinking can be synchronized across all ports in the system. For SPI, cross-device synchronization uses the SPI_LED_SYNC pin. One device is configured to forward its internal LED clock to this pin, and all other devices are configured to receive an external LED clock on this pin. For I2C, the first device in the CTRL4 to CTRL3 pin daisy chain is configured to output the internal LED clock to the CTRL4 pin. All other devices are configured to receive an external LED clock from the CTRL3 pin and to output the clock to the CTRL4 pin.

In some applications, it may be desirable to control more than two LEDs per port. In cases where the additional LEDs are relatively static in nature and blinking is not required, the GPIO and OUT_B pins of the FPC402 can be allocated for driving these LEDs in an active-low configuration. OUT_C and OUT_D must be connected to LEDs

requiring blinking, dimming, or both, and up to two additional LEDs can be controlled per port from the GPIO and OUT_B pins. OUT_B is optionally used to drive RS0/RS1 in SFP ports or LPMODE in QSFP ports. These module pins are often not used in a system and are instead pulled to 3.3 V (SFP) or GND (QSFP). The module functionality affected by these pins is anyway controllable through software.  8-2 shows an example of how up to four LEDs can be controlled per port.

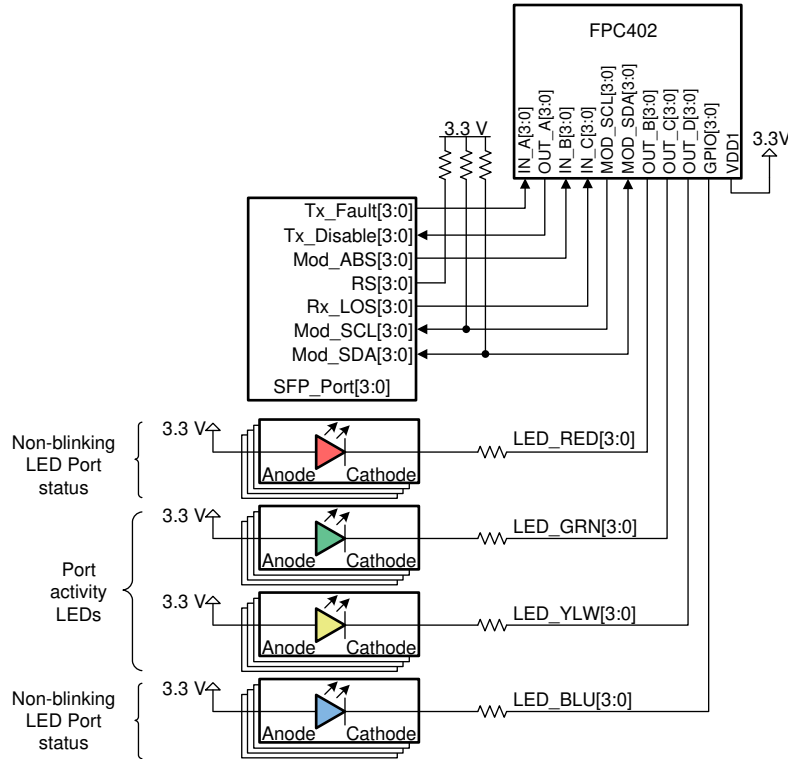

Copyright © 2017, Texas Instruments Incorporated

图 8-2. Example Configuration for Driving Four LEDs Per Port

8.3.3 Low-Speed Output Signal Control

The FPC402 has two general-purpose outputs per port which can be used to drive the low-speed inputs to the module. The host controller can change the state of these outputs for each port individually, for all ports connected to a given FPC402 device simultaneously, or for all ports in the system simultaneously.

There are two configuration registers for these outputs. One register configures the enable state of the OUT_A and OUT_B pins for every port, and by default both OUT_A and OUT_B pins are disabled (tri-stated). The second register controls the output value for all OUT_A and OUT_B pins, where OUT_A has default value of 1 and OUT_B has a default value of 0. The output values must be configured before the outputs are enabled. If a default value is desired during boot up before these pins are enabled, a 10-kΩ pullup or pulldown resistor is recommended (note that SFP and QSFP modules have internal pullup and pulldowns on certain inputs). Note that if the VDD1 rail does not have power and there is an externally powered pullup resistor connected to an output pin, the output pin will be pulled low until VDD1 is supplied.

表 8-1 provides an example signal connection. OUT_A and OUT_B are not restricted to this port pin assignment, and they can be used to drive any 3.3-V signal required for the application, provided the I_{OH} and I_{OL} limits are met.

表 8-1. Example Connections for Low-Speed FPC402 Outputs to SFP/QSFP ports

PIN NAME	EXAMPLE CONNECTION		COMMENT
	SFP	QSFP	
OUT_A	Tx_Disable	ResetL	

表 8-1. Example Connections for Low-Speed FPC402 Outputs to SFP/QSFP ports (continued)

PIN NAME	EXAMPLE CONNECTION		COMMENT
	SFP	QSFP	
OUT_B	RS0 and RS1	LPMode	RS0 and RS1 will both be driven to the same level.

8.3.4 Low-Speed Input Status and Interrupt Generation

The FPC402 has three general-purpose inputs per port which can be used to monitor the low-speed outputs from the module. The host controller can monitor the status of these signals for each port by reading the appropriate registers in the FPC402. In addition, the FPC402 can be configured to generate an interrupt to the host through the HOST_INT_N signal whenever one or more of the low-speed input signals change state. The interrupt can be configured to trigger on the falling edge, the rising edge, or both the falling and rising edges. A single register stores flags for which inputs and edges are responsible for the trigger.

The recommended signal connection is as follows. IN_A, IN_B, and IN_C are not restricted to this port pin assignment, and in fact they can be used to monitor the status of any low-speed 3.3-V signal required for the application.

表 8-2. Example Connections for Low-Speed FPC402 Inputs to SFP/QSFP ports

PIN NAME	EXAMPLE CONNECTION		COMMENT
	SFP	QSFP	
IN_A	Tx_Fault	IntL	
IN_B	Mod_ABS	ModPrsL	
IN_C	Rx_LOS	—	This pin is unused in QSFP applications, or it can be utilized as a general-purpose input.

The events which trigger an active-low interrupt on the HOST_INT_N pin are user-configurable. The HOST_INT_N pins from multiple FPC402 devices can be connected together in a wired-or fashion. Interrupt generation can be configured as follows:

表 8-3. Host-Side Interrupt Options

INTERRUPT-TRIGGERING EVENT	PIN(S) MONITORED	EXAMPLE APPLICATION ⁽¹⁾
Rising edge	IN_A	Indicates deassertion of port-side interrupt (Tx_Fault or IntL).
	IN_B	Indicates that a module has been removed.
	IN_C	Indicates loss of optical signal (Rx_LOS) for SFP applications.
	IN_A, IN_B, or IN_C	Indicates deassertion of port-side interrupt, removal of module, or loss of optical signal (Rx_LOS).
Falling edge	IN_A	Indicates assertion of port-side interrupt (Tx_Fault or IntL).
	IN_B	Indicates that a module has been inserted.
	IN_C	Indicates presence of optical signal (Rx_LOS) for SFP applications.
	IN_A, IN_B, or IN_C	Indicates assertion of port-side interrupt, insertion of module, or presence of optical signal (Rx_LOS).
Rising or falling edge	IN_A	Indicates assertion or deassertion of port-side interrupt (Tx_Fault or IntL).
	IN_B	Indicates that a module has been inserted/removed.
	IN_C	Indicates presence or absence of optical signal (Rx_LOS) for SFP applications.
	IN_A, IN_B, or IN_C	Indicates assertion or deassertion of port-side interrupt, the insertion or removal of module, or the presence or absence of optical signal (Rx_LOS).

(1) Example applications assume that IN_A, IN_B, and IN_C are connected to the downstream ports as per the example connection table, 表 8-2.

The FPC402 is also able to generate an interrupt based on prefetched data. This is known as a data-driven interrupt. The FPC402 monitors up to four bytes within the prefetched range for each port. For each of the bytes, the register offset address is programmed to a local FPC402 register as well as the enable bit fields which will trigger the interrupt. When one of the enabled bits of the four monitored bytes changes state from a 0 to a 1 and stays a 1 for two consecutive periodic prefetch cycles (0→1→1), the interrupt is generated and the periodic prefetch operation is halted. The FPC402 has four port-specific registers which contain the sampled data from the bytes being monitored after the interrupt is triggered. To clear the interrupt, the sampled data register of the trigger source byte is read. The periodic prefetch must be restarted after the interrupt is cleared with an I2C command. Because it takes two periodic prefetch cycles to trigger this interrupt, it may take up to 10 ms for the host to see the trigger after the monitored bit field of the downstream module changes for the fastest periodic prefetch setting.

The FPC402 also has the ability to generate an interrupt if there is a mishap in the downstream I2C bus. The SDA bus and the SCL bus each have timers that will trigger an interrupt if they are held in a low state too long due to excessive clock stretching or a port error. Once the interrupt is triggered, it is cleared by issuing a port reset on the relevant port. These interrupts are known as *SCL Stuck* and *SDA Stuck* interrupts and can be configured individually for each port. By default, the *SCL Stuck* interrupt will trigger after the SCL bus is held low for 35 ms (typical). This value is configurable individually by port. The *SDA Stuck* interrupt will trigger after the SDA is held low for 1 s (typical). The user may issue a port reset sequence (9 consecutive SCL clock cycles with the last being an I2C stop condition) or module reset to restore the module to a known state.

When a host-side interrupt is triggered, the host must determine the source and cause of the interrupt. The recommended procedure for identifying the source and cause of an interrupt is as follows:

1. Read the FPC402 aggregated port interrupt flags of the first FPC402 instance to see which, if any, downstream port triggered the interrupt.
2. If this instance of the FPC402 has any aggregated port interrupts flagged, read all of the status registers to determine the source of the interrupt and clear it. If an *SCL Stuck* or *SDA Stuck* interrupt is triggered, a port reset must be issued and the periodic prefetch must be restarted. The host may also perform other housekeeping activities based on the interrupt, such as change the state of the LEDs after a module is no longer present.
3. Repeat steps 1 and 2 for the next FPC402 instance, until the HOST_INT_N bus is cleared.

This procedure applies to every FPC402 device which is wire-or'ed to the host-side interrupt signal. The total time required for the host to identify the source and cause of the interrupt for an implementation consisting of N total FPC402s, where all N HOST_INT_N outputs are wire-or'ed together, is as follows:

$T_{\text{interrupt}}$ = Delay between the IN_* pin changing state and the corresponding FPC402 device triggering an interrupt (50 μ s maximum).

T_{read} = Time required to read a single register from N FPC402 devices.

For I2C mode, $T_{\text{read}} = (9 \times 4 \times N)/F_{\text{I2C}}$, where F_{I2C} is the SCL clock frequency.

For SPI mode, $T_{\text{read}} = (29 \times 2 \times N)/F_{\text{SPI}} + T_{\text{OFF-SSN}}$, where F_{SPI} is the SCK clock frequency, and $T_{\text{OFF-SSN}}$ is the SS_N off time.

$$T_{\text{total}} = T_{\text{interrupt}} + 4 \times T_{\text{read}}$$

表 8-4 gives some examples of T_{total} for different I2C/SPI frequencies and different values of N.

表 8-4. Example Calculations for Determining the Source and Cause of a Host-Side Interrupt

MODE	F _{I2C}	F _{SPI}	N	T _{read} (ms)	T _{total} (ms)
I2C	100 kHz	–	1	0.36	1.5
I2C	100 kHz	–	4	1.44	5.8
I2C	100 kHz	–	8	2.88	11.6
I2C	100 kHz	–	12	4.32	17.3
I2C	400 kHz	–	1	0.09	0.4
I2C	400 kHz	–	4	0.36	1.5
I2C	400 kHz	–	8	0.72	2.9

表 8-4. Example Calculations for Determining the Source and Cause of a Host-Side Interrupt (continued)

MODE	F _{I2C}	F _{SPI}	N	T _{read} (ms)	T _{total} (ms)
I2C	400 kHz	–	12	1.08	4.4
I2C	1000 kHz	–	1	0.0036	0.1
I2C	1000 kHz	–	4	0.144	0.6
I2C	1000 kHz	–	8	0.288	1.2
I2C	1000 kHz	–	12	0.432	1.8
SPI	–	1 MHz	1	0.06	0.3
SPI	–	1 MHz	4	0.23	1.0
SPI	–	1 MHz	8	0.47	1.9
SPI	–	1 MHz	12	0.70	2.8
SPI	–	10 MHz	1	0.01	0.1
SPI	–	10 MHz	4	0.02	0.1
SPI	–	10 MHz	8	0.05	0.2
SPI	–	10 MHz	12	0.07	0.3

Click [here](#) to request access to the *FPC401 Programmer's Guide* (SNLU221) for more details on how to configure the interrupts.

8.3.5 Downstream (Port-Side) I2C Master

The FPC402 has four master I2C interfaces for managing up to four ports, referred to as *downstream* ports. Each downstream I2C interface can be configured to operate with an SCL clock frequency between 100 kHz and 400 kHz (maximum). The downstream I2C master supports clock stretching.

The SFF-8472 and SFF-8431 specifications define up to two logical device addresses per SFP port: 0xA0 and 0xA2. The SFF-8436 specification defines one logical device address per QSFP port: 0xA0. Both 0xA0 and 0xA2 are directly addressable by the upstream host controller by default. The directly accessible addresses may be modified through I2C writes to the FPC402 such that any valid I2C address is directly accessible. Refer to [表 8-6](#) (I2C) and [表 8-7](#) (SPI). The FPC402 uses this address mapping scheme to decode the port and device address and perform a downstream I2C read or write operation. This is known as a remote access. Remote accesses have the highest priority when accessing the downstream module. If there is an on-going periodic prefetch or scheduled write, these operations will be stopped at the next byte boundary and the remote access will be executed. The periodic prefetch or schedule write operation will be resumed after the remote access finishes. Note that the periodic prefetch will begin from the starting register offset of the prefetch range rather than where it left off during the interruption. If a remote access is attempted during an interrupt-driven prefetch, the interrupt-driven prefetch will finish and the remote access is executed afterwards. If an autonomous access (prefetch or scheduled write) occurs during a remote access, the autonomous access is executed after the remote access is completed.

8.3.6 Data Prefetch From Modules

The FPC402 can be configured to prefetch data from each module of the downstream port. The prefetched data is stored locally in the memory of the device, allowing any downstream read operations in the prefetch range to be directly read from the FPC402 rather than waiting for the FPC402 to read from the downstream device through I2C. The FPC402 can prefetch data from the ports on a one-time basis, a regular basis (periodic prefetch), or upon the occurrence of certain events (interrupt-driven prefetch).

For periodic prefetching, the period is configured in steps of 5 ms from 0 to 1.275 s, where 0 is a one-time prefetch. The prefetched range is determined by two settings, the prefetch length and the prefetch offset address. The FPC402 will prefetch beginning at the offset address for a length of bytes between 1 and 32. The target device is configured between downstream device 0 and device 1, and both of these device addresses are fully configurable to any valid I2C address. By default, these addresses are 0xA0 and 0xA2 respectively. Once configured, the start bit is set to begin periodic prefetching and the stop bit is set to stop prefetching. After a prefetch is completed, the gate bit is set to 0, and any attempted read operation in the prefetched range will

return data from the FPC402's memory containing the last prefetched data. To modify the prefetched range or to stop the FPC402 from returning the data from memory, the gate bit must be reset to 1. If the FPC402 receives a NACK during a prefetch attempt, the gate bit will automatically be reset. Each port has its own gate bit and separate memory and settings.

For interrupt-driven prefetch, the interrupt event can be configured for either the rising- or falling-edge of one of the IN_[A,B,C] input signals of a port. The prefetch range and target device address is configured similarly but independently of the periodic prefetch settings. Interrupt-driven prefetch also has a gate bit and memory independent of the periodic prefetch. Once an interrupt-driven prefetch occurs successfully, an interrupt is triggered on the HOST_INT_N pin and the aggregated interrupt flag for that port will be set. For the interrupt to be cleared and for another interrupt prefetch to occur, it must be re-armed with a register write. If the prefetch attempt is NACK'd, the gate bit will not be set, the interrupt will not be generated, and the interrupt-driven prefetch does not need to be re-armed. Note that the prefetched data from the interrupt-driven prefetch has precedence over the data from a periodic prefetch if they have overlapping prefetch ranges. The FPC402 will return data from the interrupt-driven prefetch even if the periodic prefetch data is more recent. When an interrupt-driven prefetch occurs, TI recommends correcting this immediately by reading the prefetched data and re-arming it.

Click [here](#) to request access to the *FPC401 Programmer's Guide* (SNLU221) for more details on how to configure data prefetch.

8.3.7 Scheduled Write

The FPC402 has the ability to schedule a write operation on one or more downstream modules simultaneously by writing to local FPC402 registers. This operation, known as a scheduled write, allows for quicker writing by using the faster host-side I2C rate. The host-side I2C bus is not held while the write occurs in the downstream I2C. This command may be broadcasted to all FPC402s to write to any combination of ports concurrently. The downstream device address targeted by the scheduled write is configured between downstream device 0 and device 1, and both of these device addresses are fully configurable to any valid I2C address. By default, these addresses are 0xA0 and 0xA2, respectively.

Scheduled writes can be directed to an individual port (port scheduled write) or to a group of two or more ports simultaneously (common scheduled write). The status of the port scheduled write or common scheduled write may be checked in a local FPC402 register. This register will reflect if the operation completed successfully, or if it was NACKed by the downstream module. The on-going scheduled write command must be completed before the scheduled write settings for the target port are modified, or before a new command on the same port is issued.

Scheduled write operations have a higher priority than periodic prefetch operations. This means that if a schedule write is sent while a periodic prefetch is on-going, the periodic prefetch is stopped at the next byte boundary and the scheduled write is executed. The periodic prefetch resumes on the next period. Note that it will begin reading at the start of the prefetch range rather than where the scheduled write occurred.

Click [here](#) to request access to the *FPC401 Programmer's Guide* (SNLU221) for more details on how to configure scheduled write.

8.3.8 Protocol Timeouts

The FPC402 has a watchdog timer to ensure that the I2C buses do not become permanently stuck. For example, if the host is performing a remote access on a downstream module, the FPC402 will clock stretch the host-side I2C while the downstream I2C transaction occurs. If the downstream module clock stretches for a very long time or any other error occurs that prevents the transaction from finishing, the host-side I2C will not become stuck. The watchdog timer is what prevents this from happening by setting a maximum time for the downstream transaction to complete; and if it does not complete, the timer expires and the FPC402 will NACK the host to terminate the transaction. By default, the timer is set to 3 ms and is programmable in steps of 1 ms up to 127 ms. This timer may also be disabled, but this is not recommended as the I2C bus may become permanently stuck and a device reset will be necessary. Each port's I2C master also has a programmable watchdog timer which operates similarly to the host-side I2C watchdog timer.

When the host attempts a remote access transaction through I2C, after the I2C device ID has been ACKed, the FPC402 waits for the host to send a register offset address or a read/write command before downplaying it on the downstream port I2C. If the host becomes busy with something else and does not finish the I2C transaction, the FPC402 state machine will be stuck. There is a protocol timeout timer for each port to prevent this from happening. If the host does not finish the I2C transaction within this timer, the FPC402 will timeout and return to the idle state. This counter is 10 ms (typical) by default and is configurable in steps of 1 ms up to 255 ms.

Click [here](#) to request access to the *FPC401 Programmer's Guide* (SNLU221) for more details on how to configure protocol timeouts.

8.3.9 General-Purpose Inputs and Outputs

The FPC402 has multiple general-purpose input and output pins which can be used to control auxiliary functions on the board through the same host-side control interface which is used to manage the ports. The GPIO pins can be configured as inputs or outputs through the FPC402 registers. One example use case for these GPIO pins is to control a power switch (that is, TPS2556 or TSP2557) to enable or disable power to the modules to manage power sequencing of the modules and prevent large inrush current at board power up.

A GPIO pin can be used with an external pullup resistor to drive low-voltage I/Os on other devices. When used in this fashion, the GPIO would drive V_{OL} when set to logic 0, and when set to high-impedance (tri-state), the pullup resistor would pull the signal up to the appropriate I/O voltage. When using the GPIO pins for this purpose, it is important to drive the GPIOs to logic 0 and high-impedance only. Do not drive the GPIO to logic 1 as it would risk damaging the I/O of the connected device.

Figure 8-3 shows an example configuration for using the GPIOs to drive 1.2-V I/Os on another device.

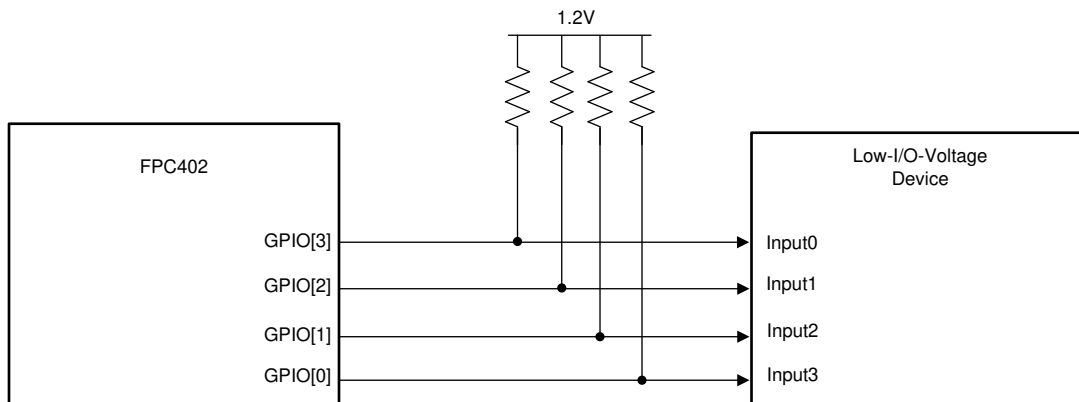

Copyright © 2017, Texas Instruments Incorporated

Figure 8-3. Example Use Of External Pullups to Drive Low-I/O-Voltage Devices From GPIOs

The GPIO pins have a driver impedance of 10 Ω (typical). This is lower than the typical characteristic impedance of a transmission line and therefore may cause ringing due to the fast edge rate. The ringing duration is a function of the transmission line length and will typically be less than 100 ns. The magnitude of the overshoot is a function of the difference of driver impedance and impedance seen by the driver and may be as large as 5 V to GND for a transmission line with a characteristic impedance of 60 Ω . If ringing is a concern, a series resistor may be placed near the GPIO pin. A good rule of thumb for sizing the resistor is the difference of the transmission line characteristic impedance minus the driver impedance. For example, in the case of a 60 Ω transmission line impedance, a 50- Ω series resistor may be used to minimize ringing. Cases such as these may be simulated using the provided FPC402 IBIS model.

8.3.10 Hot-Plug Support

The FPC402 has features which enable it to support hot-plug applications.

- Power-on-reset (PoR). The FPC402 is automatically held in reset until T_{POR} milliseconds have elapsed after VDD1 power supply is stable. The host-side control interface (I2C or SPI) must not be used prior to the completion of the PoR. Likewise, the port-side I2C interfaces are not exercised prior to the completion of the PoR.

- Enable pin (EN). When this pin is low, the FPC402 is held in reset. The host must hold this pin low until the host-side control interface (I2C or SPI) is fully connected and stable. This pin has a weak pullup such that it can be left floating for applications which do not require hot-plug or manual enable control.
- Host-side I2C false START / false STOP tolerance. The FPC402 is designed to ignore false START and STOP conditions on the host-side I2C control interface.
- Port-side glitch suppression. The FPC402 is designed to suppress glitches from the port-side module lasting less than 30 μ s (typical). This applies to all IN_* pins.

8.4 Device Functional Modes

The FPC402 has a single host-side control interface which can be configured as one of two available protocols, depending on the pin strap value of the `PROTOCOL_SEL` pin:

- Inter-Integrated Circuit (I2C) up to 1-MHz Fast-mode Plus
- Serial Peripheral Interface (SPI) up to 10 MHz

Depending on which functional mode is selected (SPI or I2C), the `CTRL[4:1]` pins will assume the corresponding behavior.

表 8-5. Host-Side Control Interface Options

HOST-SIDE INTERFACE	PROTOCOL_SEL	CTRL4	CTRL3	CTRL2	CTRL1
I2C	Float or High	ADDR_DONE_N	SET_ADDR_N	SDA	SCL
SPI	GND	MISO	MOSI	SS_N	SCK

8.4.1 I2C Host-Side Control Interface

If I2C is used as the host-side communication protocol, the maximum number of FPC402 devices which can share a single I2C bus is 14. This allows for controlling up to 56 downstream ports through a single I2C bus.

I2C is an addressed interface. To reduce pin count and simplify integration, the FPC402 has an auto-addressing scheme whereby all FPC402s in a system will take on a unique address without requiring dedicated address pins. This is accomplished by connecting one `CTRL4` (`ADDR_DONE_N`) pin of a FPC402 device to the subsequent `CTRL3` (`SET_ADDR_N`) pin of another FPC402 device. The first FPC402 will connect `CTRL3` (`SET_ADDR_N`) to GND, and the final FPC402 will connect `CTRL4` (`ADDR_DONE_N`) to GND, as shown in [Figure 8-4](#).

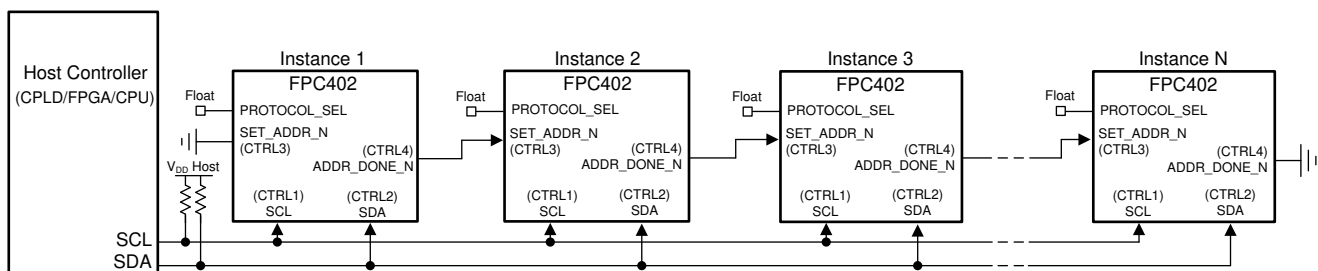

Copyright © 2017, Texas Instruments Incorporated

Figure 8-4. FPC402 Connection Diagram for Unique Addressing in I2C Mode

For I2C host-side control interface implementations, the host controller must first configure each FPC402 device to have a unique address. The `CTRL3` (`SET_ADDR_N`) pin is internally pulled to high logic (regardless of the EN pin status) and the FPC402 device will not respond to any I2C transactions until this pin is pulled low. Once it is driven to low logic, the device will respond to the default I2C 8-bit address (0x1E). A single I2C write to the FPC402 will reassign a new I2C address, and once this is done, the FPC402 will drive low logic with the `CTRL4` pin (`ADDR_DONE_N`) which allows the next FPC402 in the daisy chain to be programmed using the default address. Until this address reassignment happens, the `CTRL4` (`ADDR_DONE_N`) pin is high-Z.

This scheme allows each FPC402 to take a unique I2C address without any contention on the bus. The addresses may be programmed in any order except for the default 8-bit address (0x1E) which must be assigned to the last device in the daisy chain, or else two FPC402s will respond to 0x1E and bus contention will occur.

The state of the CTRL3 (SET_ADDR_N) pin does not matter after the address is reprogrammed (this pin is then used to transfer the LED clock for blinking synchronization). Once the new address is programmed, it becomes fixed and may no longer be changed by a new register write. Only power cycling the device or toggling the EN pin will restore the device to the default reprogrammable address.

The I2C address space for FPC402 applications is designed such that each FPC402, each port being controlled, and each logical device address within each port is accessible to the host controller through a unique I2C address. All FPC402 devices will also respond to 8-bit I2C address 0x02. This allows the host controller to broadcast write to all FPC402 devices simultaneously. For a system with up to 14 FPC402 devices on a single I2C bus, the full 8-bit I2C address map is shown in 表 8-6.

表 8-6. I2C 8-Bit Address Map

FPC402 INSTANCE NUMBER	FPC402 SELF-ADDRESS	PORT 0		PORT 1		PORT 2		PORT 3	
		DEVICE 0 DEFAULT = 0xA0 ⁽¹⁾	DEVICE 1 DEFAULT = 0xA2 ⁽¹⁾	DEVICE 0 DEFAULT = 0xA0 ⁽¹⁾	DEVICE 1 DEFAULT = 0xA2 ⁽¹⁾	DEVICE 0 DEFAULT = 0xA0 ⁽¹⁾	DEVICE 1 DEFAULT = 0xA2 ⁽¹⁾	DEVICE 0 DEFAULT = 0xA0 ⁽¹⁾	DEVICE 1 DEFAULT = 0xA2 ⁽¹⁾
ALL	0x02	–	–	–	–	–	–	–	–
0	0x04	0x20	0x22	0x24	0x26	0x28	0x2A	0x2C	0x2E
1	0x06	0x30	0x32	0x34	0x36	0x38	0x3A	0x3C	0x3E
2	0x08	0x40	0x42	0x44	0x46	0x48	0x4A	0x4C	0x4E
3	0x0A	0x50	0x52	0x54	0x56	0x58	0x5A	0x5C	0x5E
4	0x0C	0x60	0x62	0x64	0x66	0x68	0x6A	0x6C	0x6E
5	0x0E	0x70	0x72	0x74	0x76	0x78	0x7A	0x7C	0x7E
6	0x10	0x80	0x82	0x84	0x86	0x88	0x8A	0x8C	0x8E
7	0x12	0x90	0x92	0x94	0x96	0x98	0x9A	0x9C	0x9E
8	0x14	0xA0	0xA2	0xA4	0xA6	0xA8	0xAA	0xAC	0xAE
9	0x16	0xB0	0xB2	0xB4	0xB6	0xB8	0xBA	0xBC	0xBE
10	0x18	0xC0	0xC2	0xC4	0xC6	0xC8	0xCA	0xCC	0xCE
11	0x1A	0xD0	0xD2	0xD4	0xD6	0xD8	0xDA	0xDC	0xDE
12	0x1C	0xE0	0xE2	0xE4	0xE6	0xE8	0xEA	0xEC	0xEE
13	0x1E	0xF0	0xF2	0xF4	0xF6	0xF8	0xFA	0xFC	0xFE

(1) Device addresses are programmable. By default, the device 0 address is 0xA0 and the device 1 address is 0xA2. Click [here](#) to request access to the *FPC401 Programmer's Guide* (SNLU221) for more details.

The timing specification for an I2C transaction is described in 图 8-5.



图 8-5. I2C Timing Diagram

8.4.2 SPI Host-Side Control Interface

If SPI is used as the host-side communication protocol, the maximum number of FPC402 devices which can share a single SPI bus is technically unlimited. The read and write latency from/to the downstream ports will increase as the length of the SPI chain increases.

SPI does not require each FPC402 to have an address. The FPC402 devices are connected in a daisy-chain fashion as shown in 图 8-6. The first FPC402 will connect CTRL3 (MOSI) to the MOSI signal of the host controller. CTRL4 (MISO) on the first FPC402 will connect to the subsequent CTRL3 (MOSI) signal of another

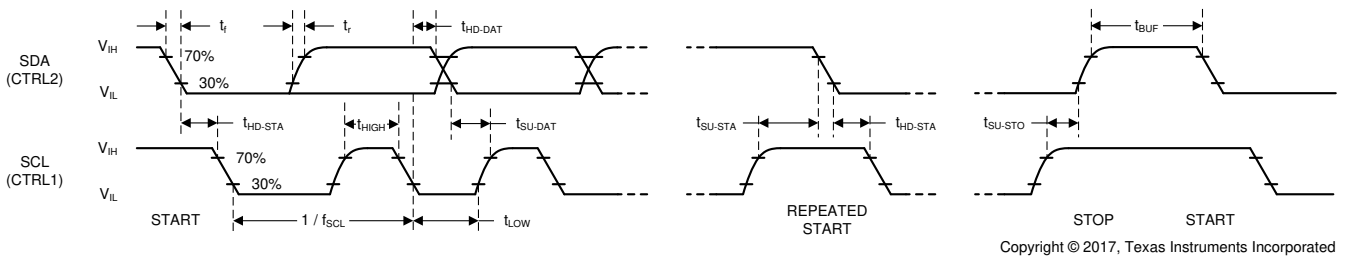
FPC402, and continues until the final CTRL4 (MISO) signal connects back to the MISO signal of the host controller. All FPC402 devices will connect CTRL1 (SCK) and CTRL2 (SS_N) to the same SCK and SS_N pin on the host controller. For LED blink synchronization across multiple FPC402 devices, the SPI_LED_SYNC pin must be connected across all FPC402 devices in SPI mode. This is not necessary in I2C mode.

Each FPC402 device in the SPI chain will capture and act upon the command in its shift register when SS_N transitions from low (0) to high (1). The MOSI input is ignored and the MISO output is high impedance whenever SS_N is deasserted high.

The prior SPI command, address, and data are shifted out on MISO as the current SPI command, address, and data are shifted in on MOSI. In all SPI transactions, the MISO output signal is enabled asynchronously whenever SS_N is asserted low.

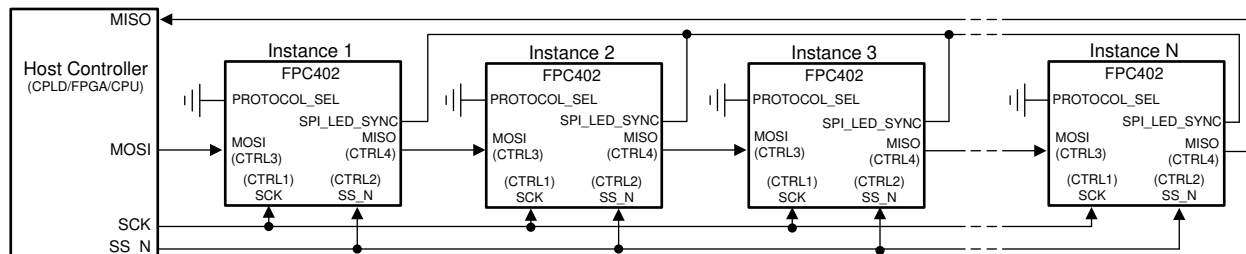

Copyright © 2017, Texas Instruments Incorporated

图 8-6. FPC402 Connection Diagram for SPI Mode

The SPI address space for FPC402 applications is designed such that each port being controlled and each logical device address within each port is accessible to the host controller through a unique 12-bit address. Refer to 表 8-7 for the appropriate address offset mapping.

For a system with up to N FPC402 devices on a single SPI chain, the full SPI address map is as follows.

表 8-7. SPI Address Map

FPC402 INSTANCE NUMBER	ADDRESS RANGE								FPC402 REGS
	PORT 0		PORT 1		PORT 2		PORT 3		
	DEVICE 0 DEFAULT = 0xA0 ⁽¹⁾	DEVICE 1 DEFAULT = 0xA2 ⁽¹⁾	DEVICE 0 DEFAULT = 0xA0 ⁽¹⁾	DEVICE 1 DEFAULT = 0xA2 ⁽¹⁾	DEVICE 0 DEFAULT = 0xA0 ⁽¹⁾	DEVICE 1 DEFAULT = 0xA2 ⁽¹⁾	DEVICE 0 DEFAULT = 0xA0 ⁽¹⁾	DEVICE 1 DEFAULT = 0xA2 ⁽¹⁾	
0									
1									
2	0x000 to 0x0FF	0x100 to 0x1FF	0x200 to 0x2FF	0x300 to 0x3FF	0x400 to 0x4FF	0x500 to 0x5FF	0x600 to 0x6FF	0x700 to 0x7FF	0x800 to 0x8FF
–									
N									

(1) Device addresses are programmable. By default, the device 0 address is 0xA0 and the device 1 address is 0xA2. Click [here](#) to request access to the *FPC401 Programmer's Guide* (SNLU221) for more details.

In SPI mode, the CTRL4 pin has a driver impedance of 60 Ω (typical). To minimize ringing due to the fast edge rate of the driver, TI recommends matching the transmission line characteristic impedance with the driver impedance. A series resistor near the driver pin (CTRL4) may be used to facilitate this impedance matching. If ringing is a concern, the IBIS model provided may be used for simulations.

8.4.2.1 SPI Frame Structure

Each SPI transaction to a single FPC402 device is 29 bits long and is framed by the assertion of SS_N (CTRL2) low. The MOSI (CTRL3) input is ignored and the MISO (CTRL4) output is high impedance whenever SS_N is deasserted high. The prior SPI command, address, and data are shifted out on MISO as the current SPI command, address, and data are shifted in on MOSI. In all SPI transactions, the MISO output signal is enabled asynchronously whenever SS_N is asserted low.

表 8-8 shows the structure of a SPI frame. 图 8-7 shows an example implementation, including the internal SPI registers, for two FPC402 devices.

表 8-8. SPI Frame Structure

BIT	FIELD	DESCRIPTION
28	R/W	0: Write command 1: Read command This is the first bit shifted in on the MOSI input.
27:16	ADDR[11:0]	12-bit address field. See 表 8-7.
15	DATA[15]	Busy flag. For read operations, a 1 means the downstream port is busy. For write operations, DATA[15] is a don't care.
14	DATA[14]	Don't care.
13	DATA[13]	NACK received flag. A 1 means the FPC402 has received a NACK from the downstream port.
12	DATA[12]	Reject flag. A 1 means the FPC402 has rejected the previous command because it is busy servicing a prior command.
11:8	DATA[11:8]	Don't care.
7:0	DATA[7:0]	8-bit data field. DATA[0] is the last bit shifted in on the MOSI input.

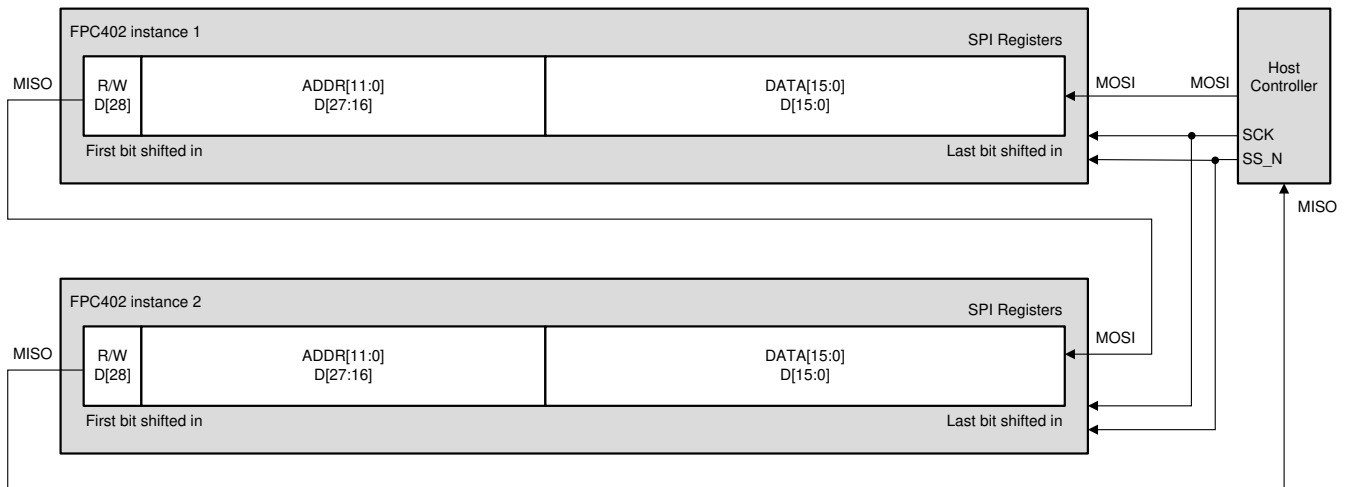

Copyright © 2017, Texas Instruments Incorporated

图 8-7. Example SPI Implementation for Two FPC402 Devices

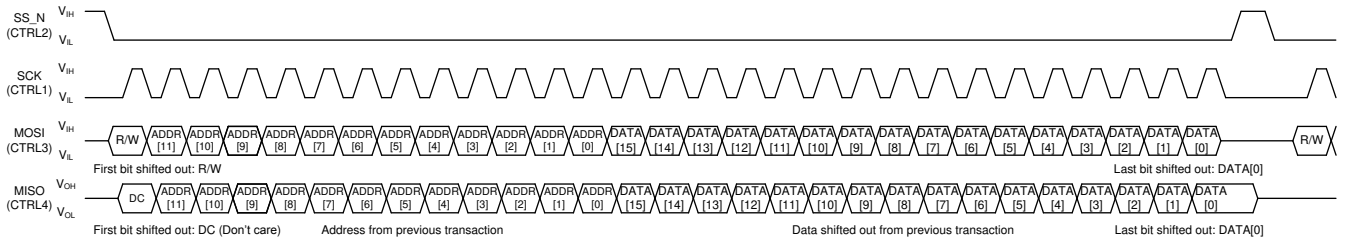

Copyright © 2017, Texas Instruments Incorporated

图 8-8. Generic SPI Transaction

The timing specification for an SPI transaction is described in 图 8-9.

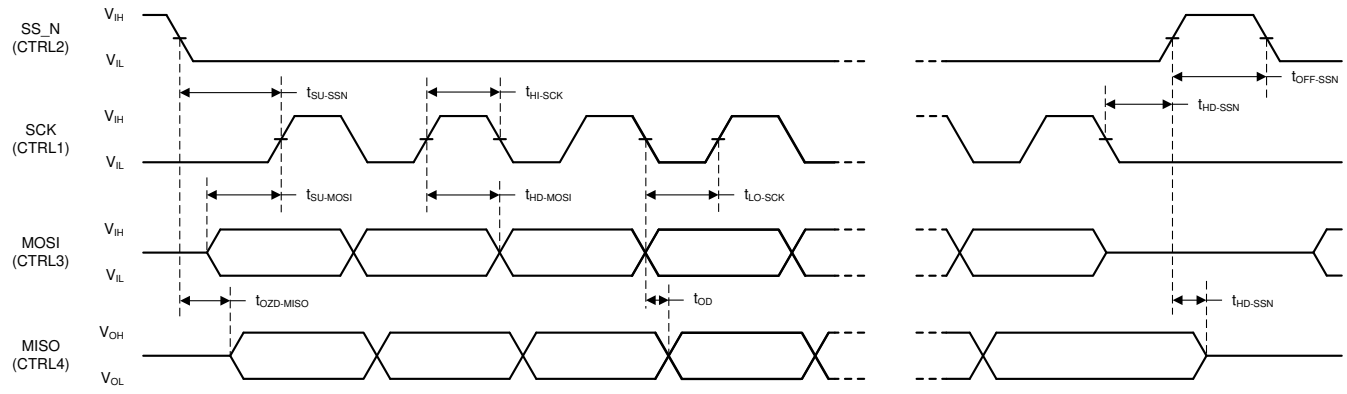

Copyright © 2017, Texas Instruments Incorporated

图 8-9. SPI Timing Diagram

8.4.2.2 SPI Read Operation

Reading data from an FPC402 device requires two complete SPI transactions as shown in 图 8-10. In between these two transactions, the FPC402 fetches the requested information from either the local FPC402 registers or from the downstream port, depending on the address specified in the read transaction. Note that for downstream (also known as remote) register reads, the required time delay between the two transactions is longer:

- Local FPC402 register reads: $t_{OFF-SSN} \geq 1 \mu s$
- Downstream (remote) register reads: $t_{OFF-SSN} \geq 170 \mu s$ assuming 400-kHz I2C; $620 \mu s$ assuming 100-kHz I2C

Also note that the second SPI transaction does not have to be a valid read or write operation and can instead be a dummy frame composed of all ones. This dummy frame is considered an invalid address by the FPC402 so it does not take any actions, but the read data from the prior frame still is shifted out and is valid. The use of a dummy frame is recommended when reading a single local FPC402 register because, if a register is read twice using the same SPI frame, any self-clearing bits will be cleared in the second frame and the received data may be incorrect.





图 8-10. SPI Read Consisting of Two Separate SPI Transactions

For downstream (remote) register reads, where the FPC402 must translate a SPI read into an I2C read transaction with the downstream port, the most significant bit of the data returned on MISO indicates whether the downstream port is busy or not. If the second SPI read transaction is executed prematurely during a downstream (remote) read, the returned data will indicate BUSY = 1. When reading from a downstream port at an address that is not prefetched into local FPC402 memory, the time in between the first SPI transaction on a port, where the read is initiated, and the second SPI transaction on the same port, where the data is returned, must be at least 170 μs for a downstream I2C rate of 400 kHz and 620 μs for a downstream I2C rate of 100 kHz. 图 8-11 shows what happens when this prescribed delay is not followed.

If a back-to-back read transaction is issued to the same downstream port before the FPC402 has completed the first read transaction, then the subsequent transaction will contain status from the second read transaction with REJECT=1, which means that the second transaction was rejected due to the downstream I2C master being busy executing the first read transaction.  8-11 shows what happens when back-to-back reads are issued to the same downstream port without allowing enough time to complete the first read.

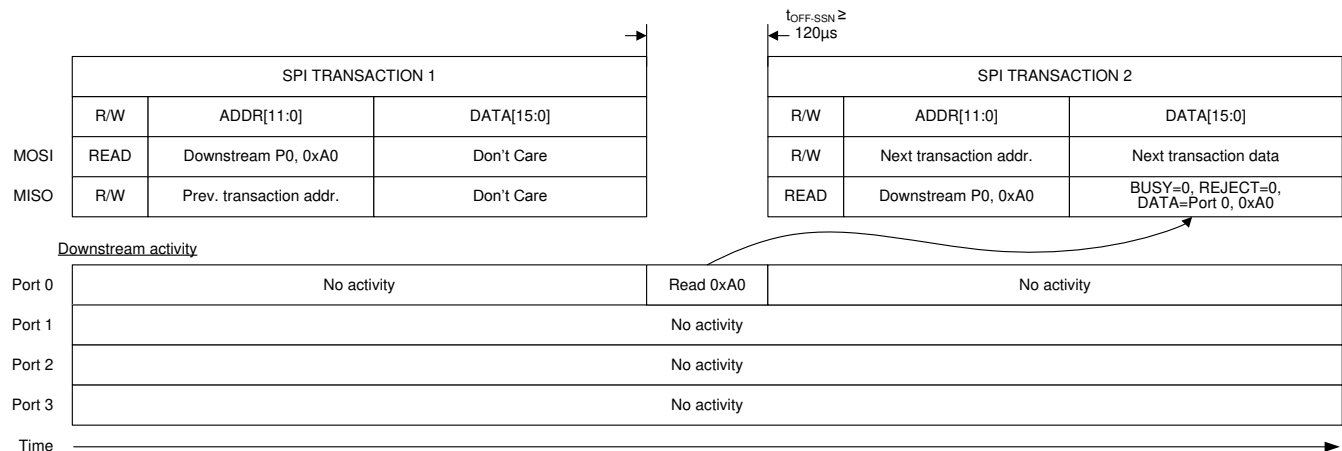

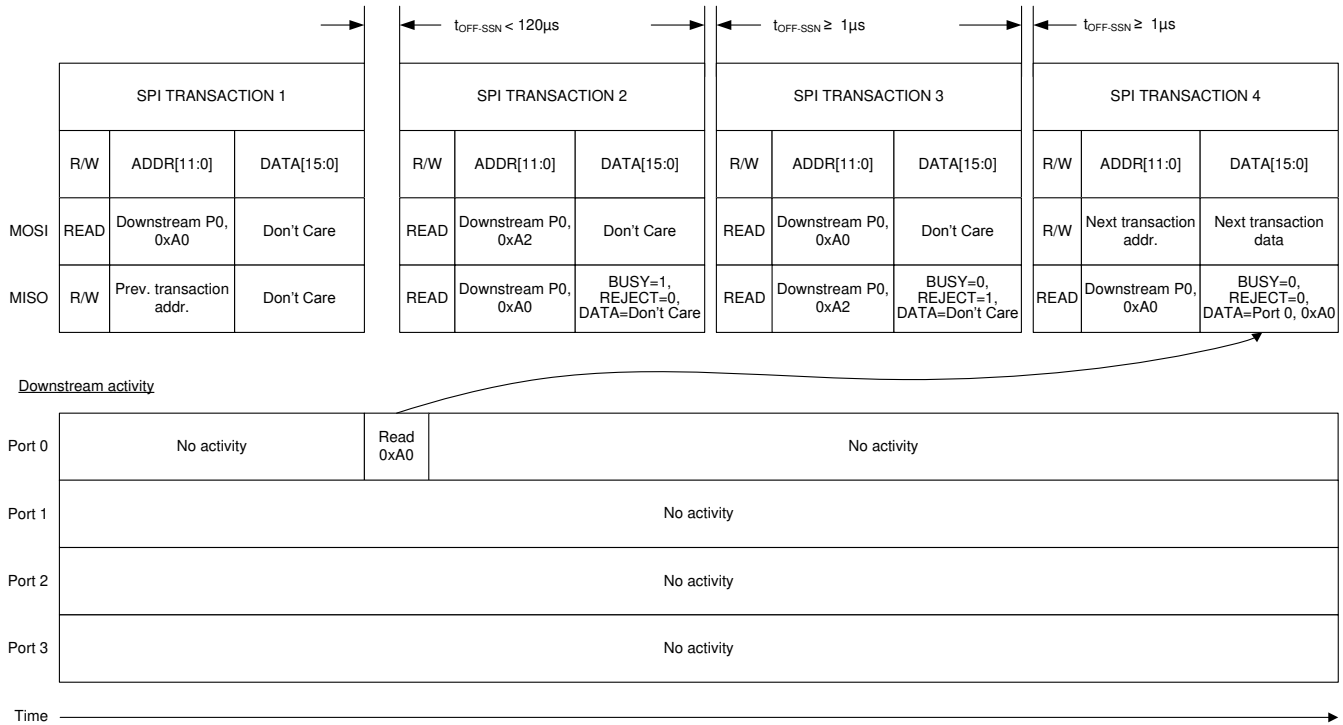
 8-11. Back-to-Back SPI Reads From Same Port

8.4.2.3 SPI Write Operation

Writing data to an FPC402 device or the downstream ports under its management requires one SPI transactions. Multiple write transactions to downstream ports can proceed with minimal delay provided that different ports are being written to. If attempting to write data to the same downstream port, then the corresponding downstream access delay, $t_{OFF-SSN}$, is required.  8-12 shows an example of writing to all four downstream ports in succession.

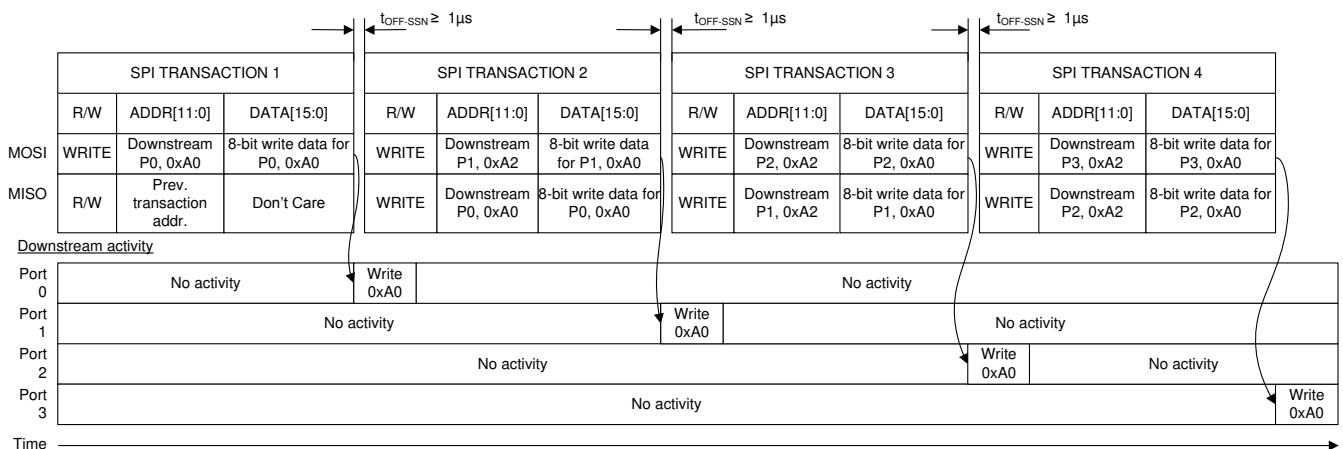

 8-12. SPI Writes to All Four Downstream Ports in Succession

8.5 Programming

Programming the FPC402 is accomplished through a single SPI or I2C interface, depending on the `PROTOCOL_SEL` pin state. To simplify configuration, a C function library is provided which can be integrated into the system software or used as a reference. The existence of basic SPI or I2C read and write functions is assumed within the provided C function library. The exact implementation of SPI or I2C read and write functions is beyond the scope of the C function library. Click [here](#) to request access to the *FPC401 Programmer's Guide* (SNLU221) more details about the register map.

9 Application and Implementation

Note

以下のアプリケーション情報は、TI の製品仕様に含まれるものではなく、TI ではその正確性または完全性を保証いたしません。個々の目的に対する製品の適合性については、お客様の責任で判断していただくことになります。お客様は自身の設計実装を検証しテストすることで、システムの機能を確認する必要があります。

9.1 Application Information

The FPC402 is general-purpose and can be used to control a variety of interfaces including, but not limited to, SFP, QSFP, Mini-SAS HD, and others. The following sections describe typical applications and their associated design considerations.

9.2 Typical Application

The FPC402 is typically used in the following application scenarios:

1. SFP/QSFP port management
2. Mini-SAS HD port management

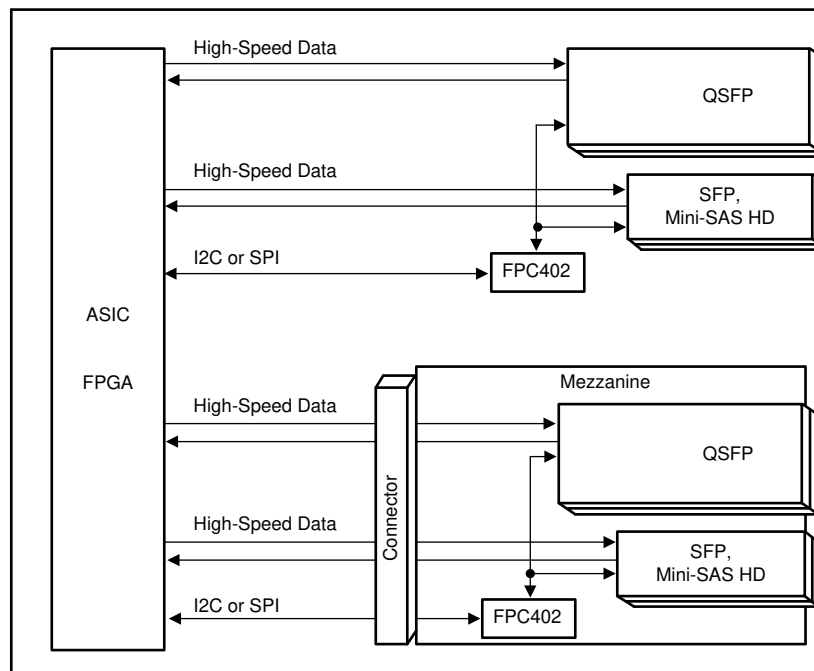

Copyright © 2017, Texas Instruments Incorporated

図 9-1. Typical Uses for the FPC402 in a System

9.2.1 SFP/QSFP Port Management

The FPC402 can be used to manage the low-speed signals, I2C, and LEDs for multiple SFP and/or QSFP ports, up to four per FPC402 device. The FPC402 package is optimized to allow placement underneath an SFP or QSFP port on the opposite side of the board. This allows hardware designers to terminate all SFP/QSFP low-speed signals close to the port and route a single I2C or SPI interface back to the system controller (ASIC or FPGA). [図 9-2](#) shows an example of this application where two FPC402 devices are used to control two QSFP ports and six SFP ports, in addition to controlling LEDs and two TPS2556 power distribution switches. [図 9-3](#) shows an example schematic for the first four ports of this application.

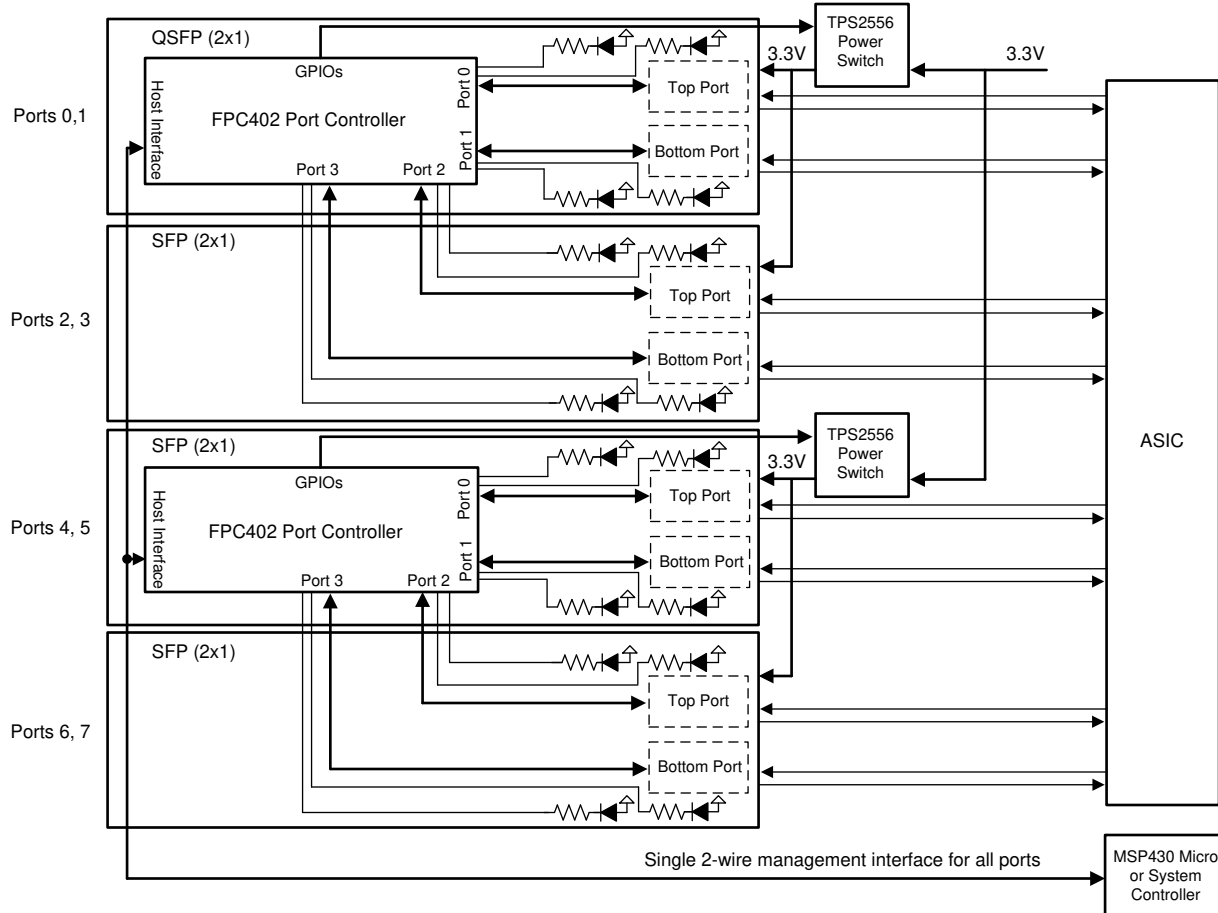

Copyright © 2017, Texas Instruments Incorporated

9-2. SFP/QSFP Application Block Diagram

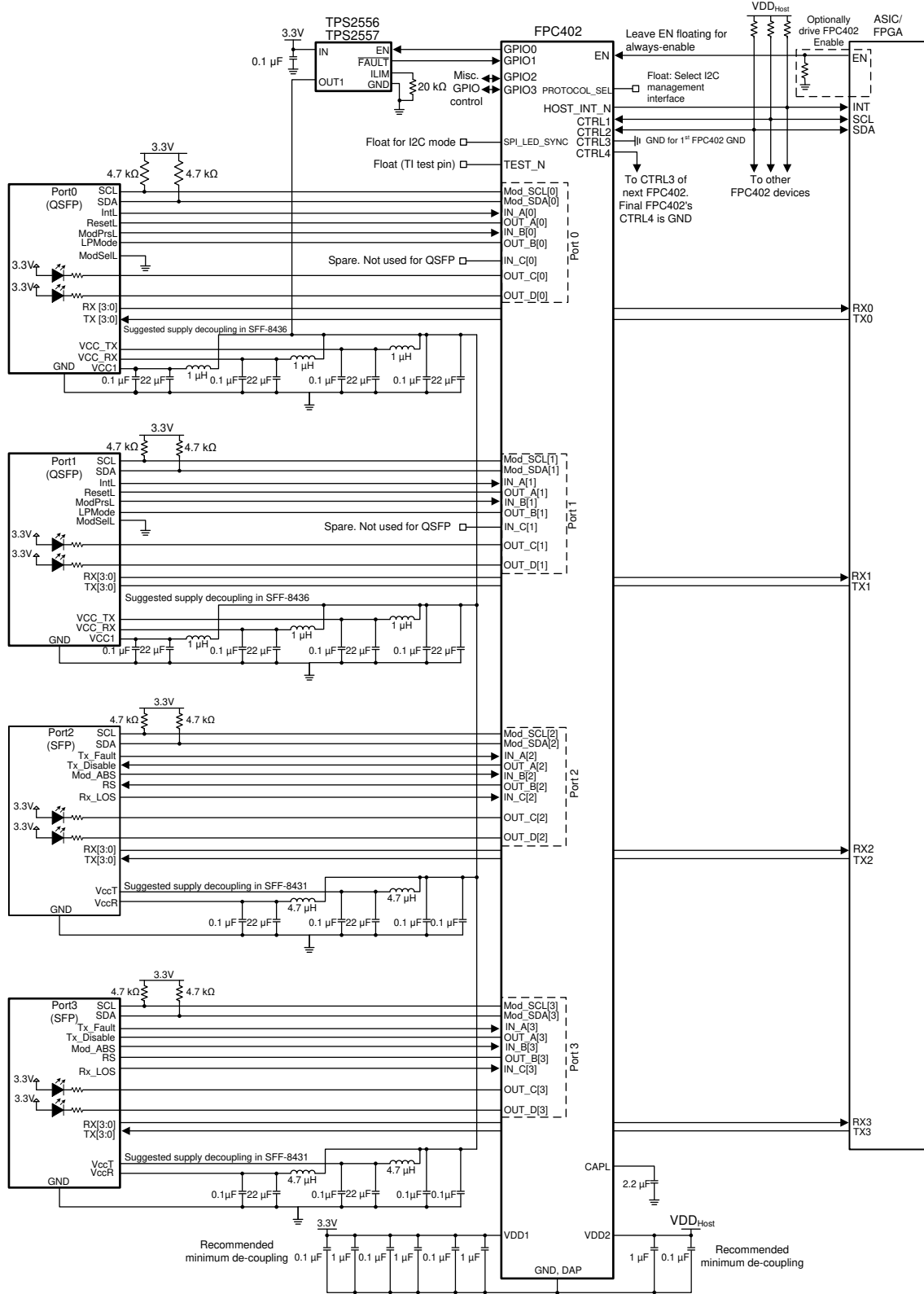

Copyright © 2017, Texas Instruments Incorporated

9-3. SFP/QSFP Application Schematic

9.2.1.1 Design Requirements

For this design example, the following guidelines outlined in [表 9-1](#) apply.

表 9-1. SFP/QSFP Application Design Guidelines

DESIGN PARAMETER	REQUIREMENT
FPC402 physical placement	The FPC402 package is small enough to fit underneath an SFP or QSFP cage, on the opposite side of the board. For SFP applications, such a placement leaves 4.6 mm of air gap between the FPC402 package edge and the SFP pressfit pins (assuming 14.25 mm pin-to-pin spacing for a stacked SFP cage). For QSFP applications, such a placement leaves 7.2 mm of air gap between the FPC402 package edge and the QSFP pressfit pins (assuming 19.5 mm pin-to-pin spacing for a stacked QSFP cage).
LED implementation	The FPC402 is designed to drive active-low LEDs which have their anode connected to the port-side 3.3 V supply. Refer to セクション 8.3.2 .
Port-side I2C SDA and SCL pullups	As per the SFF-8431 and SFF-8436 specification, the port-side (downstream) SCL and SDA nets must be pulled up to 3.3 V using resistors in the 4.7-kΩ to 10-kΩ range.
SFP Rate Select, RS0 and RS1	The SFP module provides two inputs RS0 and RS1 that can optionally be used for rate selection. RS0 controls the receive path signaling rate capability, and RS1 controls the transmit path signaling rate capability. In the vast majority of applications, the receive and transmit rates will coincide, and RS0 and RS1 can be controlled by the same pin on the FPC402: OUT_B. For applications where RS0 and RS1 must be controlled independently, the GPIO[3:0] pins can be used in conjunction with OUT_B[3:0] to control both RS0 and RS1.
QSFP ModSelL	QSFP provides a mechanism to enable or disable the port's I2C interface. Because the FPC402 has a separate I2C master to communicate with each port, the ModSelL input for every QSFP can be connected to GND, thereby permanently enabling each QSFP port's I2C bus.
SFP/QSFP port power supply de-coupling	Follow the SFF-8431 and SFF-8436 recommendations for power supply de-coupling.

9.2.1.2 Detailed Design Procedure

The design procedure for SFP/QSFP applications is as follows:

- Determine the total number of ports in the system, N_{ports} , which require management through an FPC402 device. The minimum number of FPC402 devices required to support N_{ports} is $\text{ceiling}\{N_{ports}/4\}$.
- Determine which host-side control interface will be used to manage all FPC402 devices and all ports: I2C or SPI.
- For I2C applications:
 - Up to 14 FPC402 devices can share a single host-side I2C control bus. If more than 14 FPC402 devices are used, then more than one I2C control bus will be required.
 - Take care to ensure the I2C clock (SCL) and data (SDA) lines do not exceed the maximum bus capacitance defined in [セクション 7.5](#). The bus capacitance will consist of the pin capacitance from each device connected plus the trace capacitance.
 - Make sure appropriate pullup resistors are selected for the I2C clock (SCL) and data (SDA) lines.
- For SPI applications:
 - When using SPI for host-side communications, technically there is no limit to the number of FPC402 devices which can exist on the SPI chain. However, the user must be aware that for SPI communication, skew is introduced between the SCK and MISO lines due to the propagation delay of the data through all of the devices and trace and then back to the host. It is up to the user to ensure that SPI timings of the host are met after any skew due to propagation delay.
 - Take care to ensure the SPI clock (SCK) and data (MOSI and MISO) lines do not exceed the maximum bus capacitance defined in [セクション 7.5](#). The bus capacitance will consist of the pin capacitance from each device connected plus the trace capacitance.

5. Route the low-speed inputs (IN_*[3:0]), outputs (OUT_*[3:0]), and I2C signals (MOD_SCL[3:0] / MOD_SDA[3:0]) from the FPC402 to the corresponding port, keeping all the signals for a given port grouped together. For example, if FPC402 port 2 is being used to control QSFP port 7, then all of low-speed signals of the QSFP port 7s , LED signals, and I2C signals must connect to FPC402 pins IN_*[2], OUT_*[2], and MOD_SCL[2]/MOD_SDA[2].
6. Use the spare GPIO[3:0] signals to control miscellaneous functions on the board, like enabling and disabling a power switch.
7. For applications requiring hot-plug between the FPC402 and the host controller, control the FPC402 enable signal (EN, pin 22) such that EN is deasserted low until VDD2 and the host-side control interface (I2C or SPI) is fully connected and stable.

9.2.1.3 Application Curves

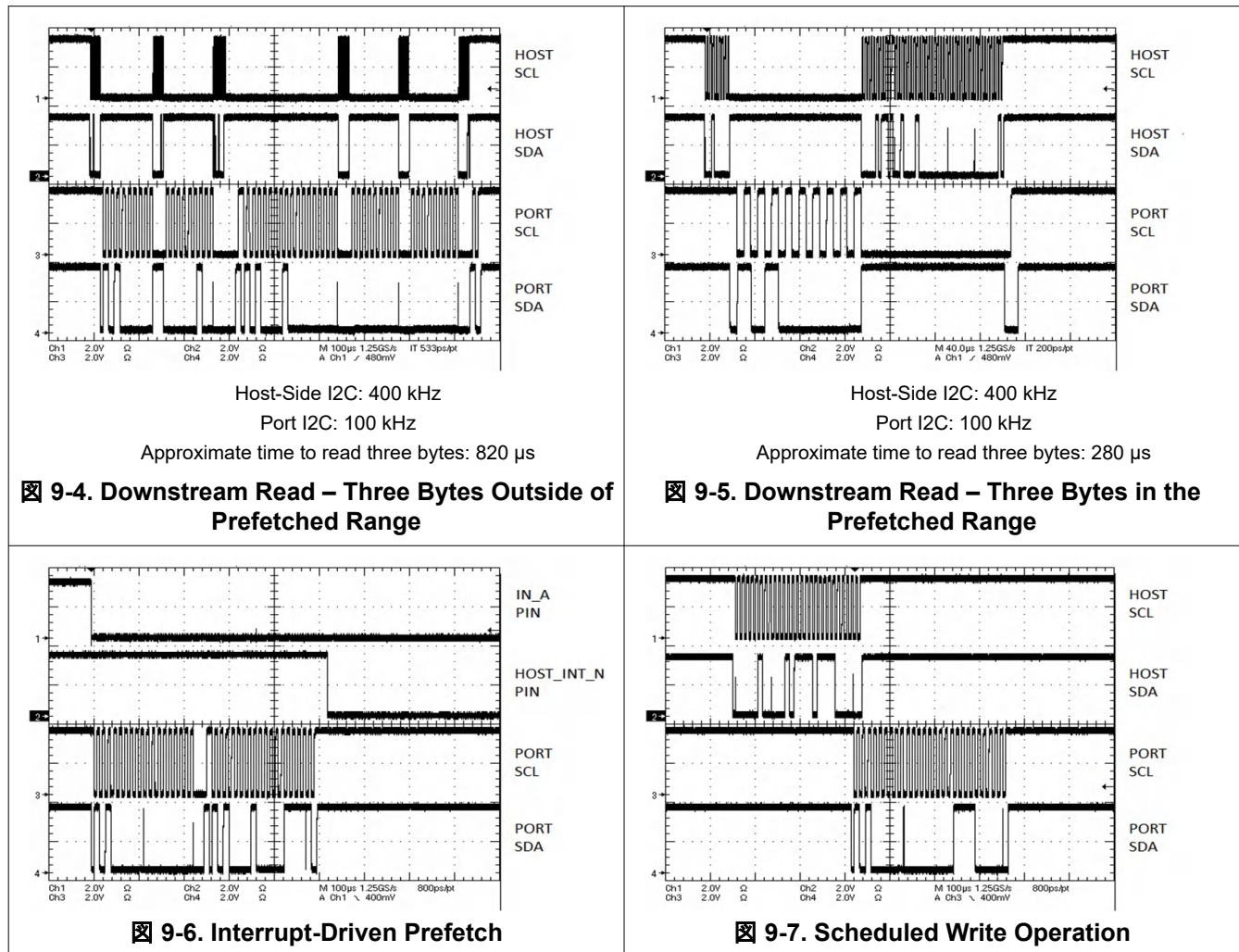

10 Power Supply Recommendations

Follow these general guidelines when designing the power supply:

1. The port-side supply, VDD1, must be 3.3-V (typical) and must meet the recommended operating conditions outlined in [セクション 7.3](#) in terms of DC voltage, AC noise, and start-up ramp time. If using the FPC402 to control a power switch to enable or disable power to the front-port connectors, the FPC402 must be connected to 3.3-V power on the input side of the switch.
2. The host-side supply, VDD2, must be 1.8 V to 3.3 V (typical) and must meet the recommended operating conditions outlined in [セクション 7.3](#) in terms of DC voltage, AC noise, and start-up ramp time.
3. The maximum current draw for the FPC402 is provided in [セクション 7.5](#). This figure can be used to calculate the maximum current the supply must provide.
4. The FPC402 does not require any special power supply filtering (that is, ferrite bead), provided the recommended operating conditions are met. Only standard decoupling is required. See [セクション 6](#) for details concerning the recommended supply decoupling for each pin.

10.1 Power Supply Sequencing

There are no sequencing requirements for the VDD1 and VDD2 power supplies. Note, however, that the FPC402 will not respond to host-side communications (SPI or I2C) until both of the following conditions are met:

1. The internal power-on-reset (PoR) is complete. Power-on-reset lasts for T_{POR} milliseconds after the VDD1 supply reaches a stable voltage (see [セクション 7.6](#)).
2. The VDD2 (host-side) supply reaches a stable voltage.

11 Layout

11.1 Layout Guidelines

The following guidelines must be followed when designing the layout:

1. Decoupling capacitors must be placed as close to the VDD1/VDD2 pins as possible.
2. The die attach pad (DAP) must have a low-impedance connection to the nearest GND plane. This is typically accomplished with vias connecting the surface GND plane to inner-layer GND planes. One recommended option is to place 14 vias spaced ≥ 1.0 mm apart in a seven by two grid as shown in [Figure 11-1](#).
3. When placing the FPC402 underneath an SFP or QSFP cage, on the opposite side of the PCB, as shown in [Figure 11-1](#), take note of the SFP/QSFP keep-out areas as well as any keep-out area required for the pressfit assembly tooling.
4. Pin 32 (CAPL) must have a low-impedance, low-inductance path to a 2.2- μ F decoupling capacitor to GND. If space constraints force this capacitor to be placed away from the pin, then a wider metal trace (that is, 20 mil) to the capacitor, using an inner layer if necessary, is recommended.
5. A GND pin is provided (pin 27) to make it easy to probe GND near the FPC402, especially in applications where the opposite side of the PCB is covered by an SFP or QSFP cage and therefore inaccessible. To maximize the benefit of this probe point, connect this pin to the local GND plane (that is, to the DAP and associated GND vias) through a low-impedance trace. In addition, it may be helpful to route a short trace to a probe point for easy access.

11.2 Layout Example

The following layout example shows how the FPC402 can be placed underneath a stacked SFP cage, on the opposite side of the PCB. In this example, the FPC402 is being used to control four ports: two SFP ports and two QSFP ports. In addition, the FPC402 is using two of its GPIO pins to control a TPS2556 power distribution switch which is placed beneath the QSFP cage. Note that there are multiple ways to route the low-speed control signals and I2C signal between the cages and the FPC402. This example uses two inner layers to accomplish this routing.

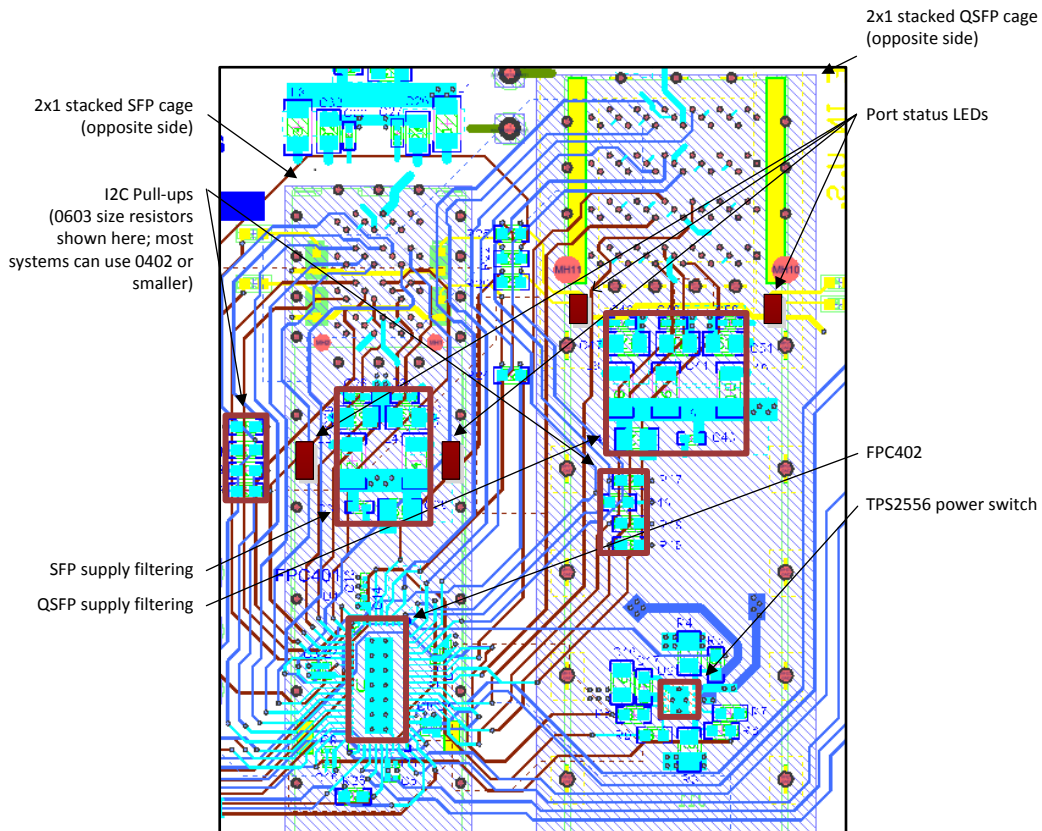

Copyright © 2017, Texas Instruments Incorporated

图 11-1. Layout Example

11.3 Recommended Package Footprint

Figure 11-2 shows the recommended package footprint for this device. The dimensions are in millimeters.

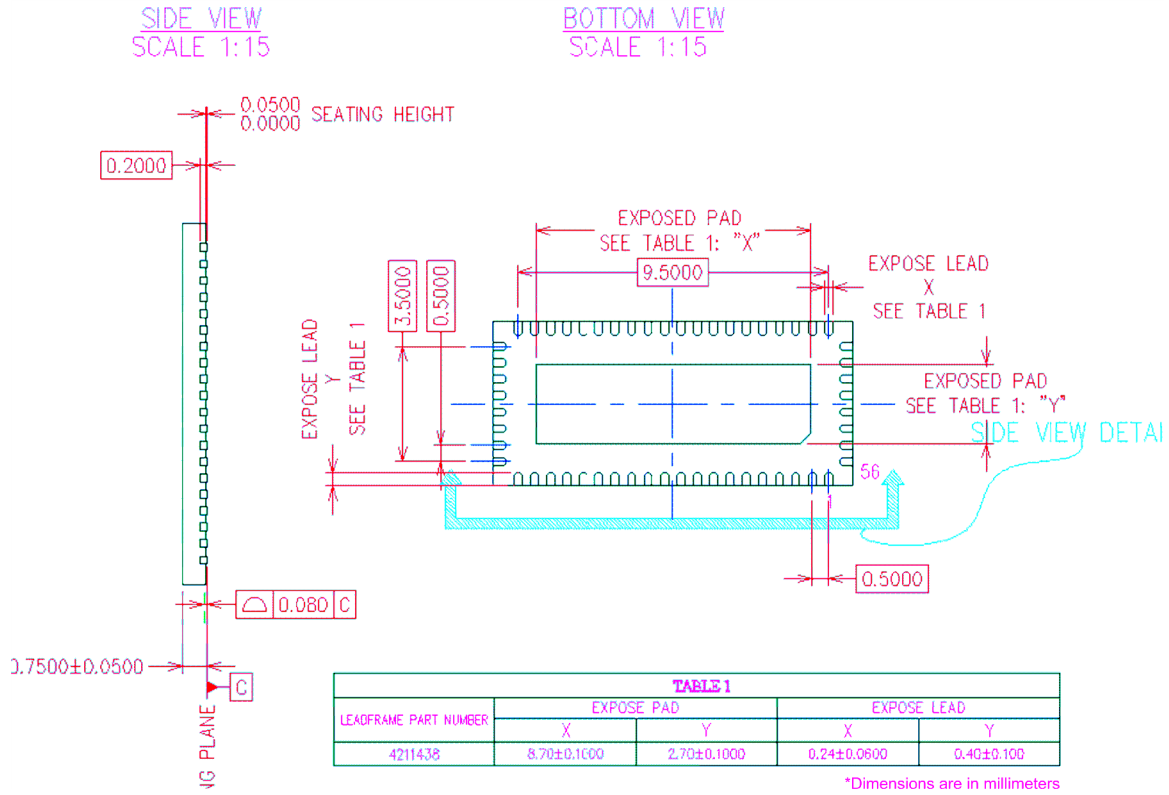

Figure 11-2. Recommended Package Footprint

12 Device and Documentation Support

12.1 Documentation Support

12.1.1 Related Documentation

For related documentation see the following:

- [FPC402 Programmer's Guide](#) (SNLU227)
- [FPC401 Evaluation Module \(EVM\) User's Guide](#) (SNLU222)

12.2 ドキュメントの更新通知を受け取る方法

ドキュメントの更新についての通知を受け取るには、[ti.com](#) のデバイス製品フォルダを開いてください。「更新の通知を受け取る」をクリックして登録すると、変更されたすべての製品情報に関するダイジェストを毎週受け取れます。変更の詳細については、修正されたドキュメントに含まれている改訂履歴をご覧ください。

12.3 サポート・リソース

TI E2E™ サポート・フォーラムは、エンジニアが検証済みの回答と設計に関するヒントをエキスパートから迅速かつ直接得ることができる場所です。既存の回答を検索したり、独自の質問をしたりすることで、設計に必要な支援を迅速に得ることができます。

リンクされているコンテンツは、該当する貢献者により、現状のまま提供されるものです。これらは TI の仕様を構成するものではなく、必ずしも TI の見解を反映したものではありません。TI の [使用条件](#) を参照してください。

12.4 Trademarks

TI E2E™ is a trademark of Texas Instruments.

すべての商標は、それぞれの所有者に帰属します。

12.5 静電気放電に関する注意事項



この IC は、ESD によって破損する可能性があります。テキサス・インスツルメンツは、IC を取り扱う際には常に適切な注意を払うことを推奨します。正しい ESD 対策をとらないと、デバイスを破損するおそれがあります。

ESD による破損は、わずかな性能低下からデバイスの完全な故障まで多岐にわたります。精密な IC の場合、パラメータがわずかに変化するだけで公表されている仕様から外れる可能性があるため、破損が発生しやすくなっています。

12.6 用語集

TI 用語集 この用語集には、用語や略語の一覧および定義が記載されています。

13 Mechanical, Packaging, and Orderable Information

The following pages include mechanical, packaging, and orderable information. This information is the most current data available for the designated devices. This data is subject to change without notice and revision of this document. For browser-based versions of this data sheet, refer to the left-hand navigation.

PACKAGING INFORMATION

Orderable Device	Status (1)	Package Type	Package Drawing	Pins	Package Qty	Eco Plan (2)	Lead finish/ Ball material (6)	MSL Peak Temp (3)	Op Temp (°C)	Device Marking (4/5)	Samples
FPC402RHUR	ACTIVE	WQFN	RHU	56	2000	RoHS & Green	SN	Level-2-260C-1 YEAR	-40 to 85	FPC402	Samples
FPC402RHUT	ACTIVE	WQFN	RHU	56	250	RoHS & Green	SN	Level-2-260C-1 YEAR	-40 to 85	FPC402	Samples

(1) The marketing status values are defined as follows:

ACTIVE: Product device recommended for new designs.

LIFEBUY: TI has announced that the device will be discontinued, and a lifetime-buy period is in effect.

NRND: Not recommended for new designs. Device is in production to support existing customers, but TI does not recommend using this part in a new design.

PREVIEW: Device has been announced but is not in production. Samples may or may not be available.

OBsolete: TI has discontinued the production of the device.

(2) **RoHS:** TI defines "RoHS" to mean semiconductor products that are compliant with the current EU RoHS requirements for all 10 RoHS substances, including the requirement that RoHS substance do not exceed 0.1% by weight in homogeneous materials. Where designed to be soldered at high temperatures, "RoHS" products are suitable for use in specified lead-free processes. TI may reference these types of products as "Pb-Free".

RoHS Exempt: TI defines "RoHS Exempt" to mean products that contain lead but are compliant with EU RoHS pursuant to a specific EU RoHS exemption.

Green: TI defines "Green" to mean the content of Chlorine (Cl) and Bromine (Br) based flame retardants meet JS709B low halogen requirements of <=1000ppm threshold. Antimony trioxide based flame retardants must also meet the <=1000ppm threshold requirement.

(3) MSL, Peak Temp. - The Moisture Sensitivity Level rating according to the JEDEC industry standard classifications, and peak solder temperature.

(4) There may be additional marking, which relates to the logo, the lot trace code information, or the environmental category on the device.

(5) Multiple Device Markings will be inside parentheses. Only one Device Marking contained in parentheses and separated by a "~" will appear on a device. If a line is indented then it is a continuation of the previous line and the two combined represent the entire Device Marking for that device.

(6) Lead finish/Ball material - Orderable Devices may have multiple material finish options. Finish options are separated by a vertical ruled line. Lead finish/Ball material values may wrap to two lines if the finish value exceeds the maximum column width.

Important Information and Disclaimer:The information provided on this page represents TI's knowledge and belief as of the date that it is provided. TI bases its knowledge and belief on information provided by third parties, and makes no representation or warranty as to the accuracy of such information. Efforts are underway to better integrate information from third parties. TI has taken and continues to take reasonable steps to provide representative and accurate information but may not have conducted destructive testing or chemical analysis on incoming materials and chemicals. TI and TI suppliers consider certain information to be proprietary, and thus CAS numbers and other limited information may not be available for release.

In no event shall TI's liability arising out of such information exceed the total purchase price of the TI part(s) at issue in this document sold by TI to Customer on an annual basis.

TAPE AND REEL INFORMATION

QUADRANT ASSIGNMENTS FOR PIN 1 ORIENTATION IN TAPE

*All dimensions are nominal

Device	Package Type	Package Drawing	Pins	SPQ	Reel Diameter (mm)	Reel Width W1 (mm)	A0 (mm)	B0 (mm)	K0 (mm)	P1 (mm)	W (mm)	Pin1 Quadrant
FPC402RHUR	WQFN	RHU	56	2000	330.0	24.4	5.3	11.3	1.0	8.0	24.0	Q1
FPC402RHUT	WQFN	RHU	56	250	178.0	24.4	5.3	11.3	1.0	8.0	24.0	Q1

TAPE AND REEL BOX DIMENSIONS

*All dimensions are nominal

Device	Package Type	Package Drawing	Pins	SPQ	Length (mm)	Width (mm)	Height (mm)
FPC402RHUR	WQFN	RHU	56	2000	356.0	356.0	45.0
FPC402RHUT	WQFN	RHU	56	250	213.0	191.0	55.0

RHU0056A

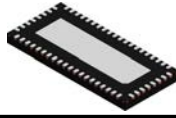

PACKAGE OUTLINE

WQFN - 0.8 mm max height

PLASTIC QUAD FLATPACK - NO LEAD

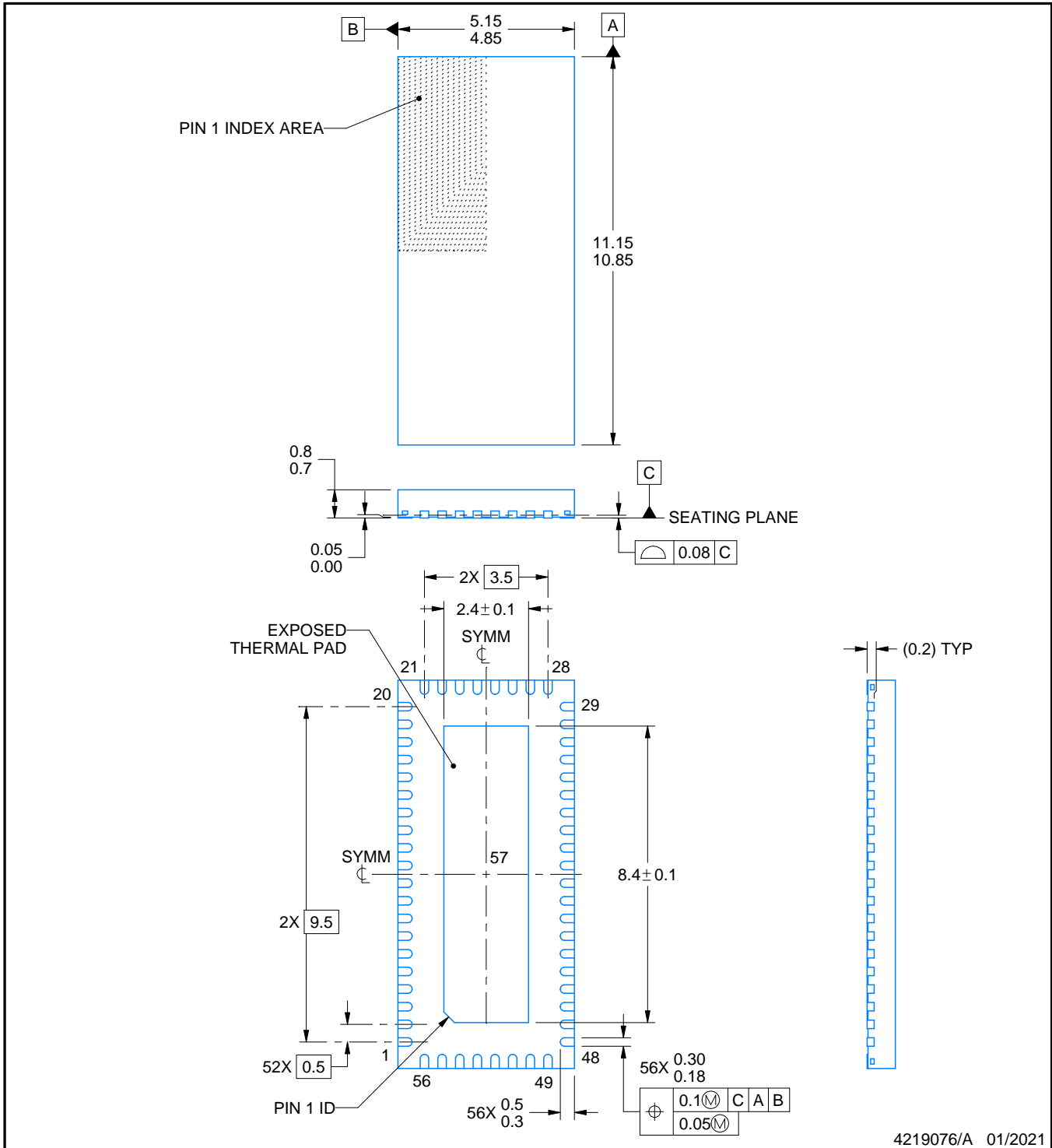

NOTES:

1. All linear dimensions are in millimeters. Any dimensions in parenthesis are for reference only. Dimensioning and tolerancing per ASME Y14.5M.
2. This drawing is subject to change without notice.
3. The package thermal pad must be soldered to the printed circuit board for thermal and mechanical performance.

EXAMPLE BOARD LAYOUT

RHU0056A

WQFN - 0.8 mm max height

PLASTIC QUAD FLATPACK - NO LEAD

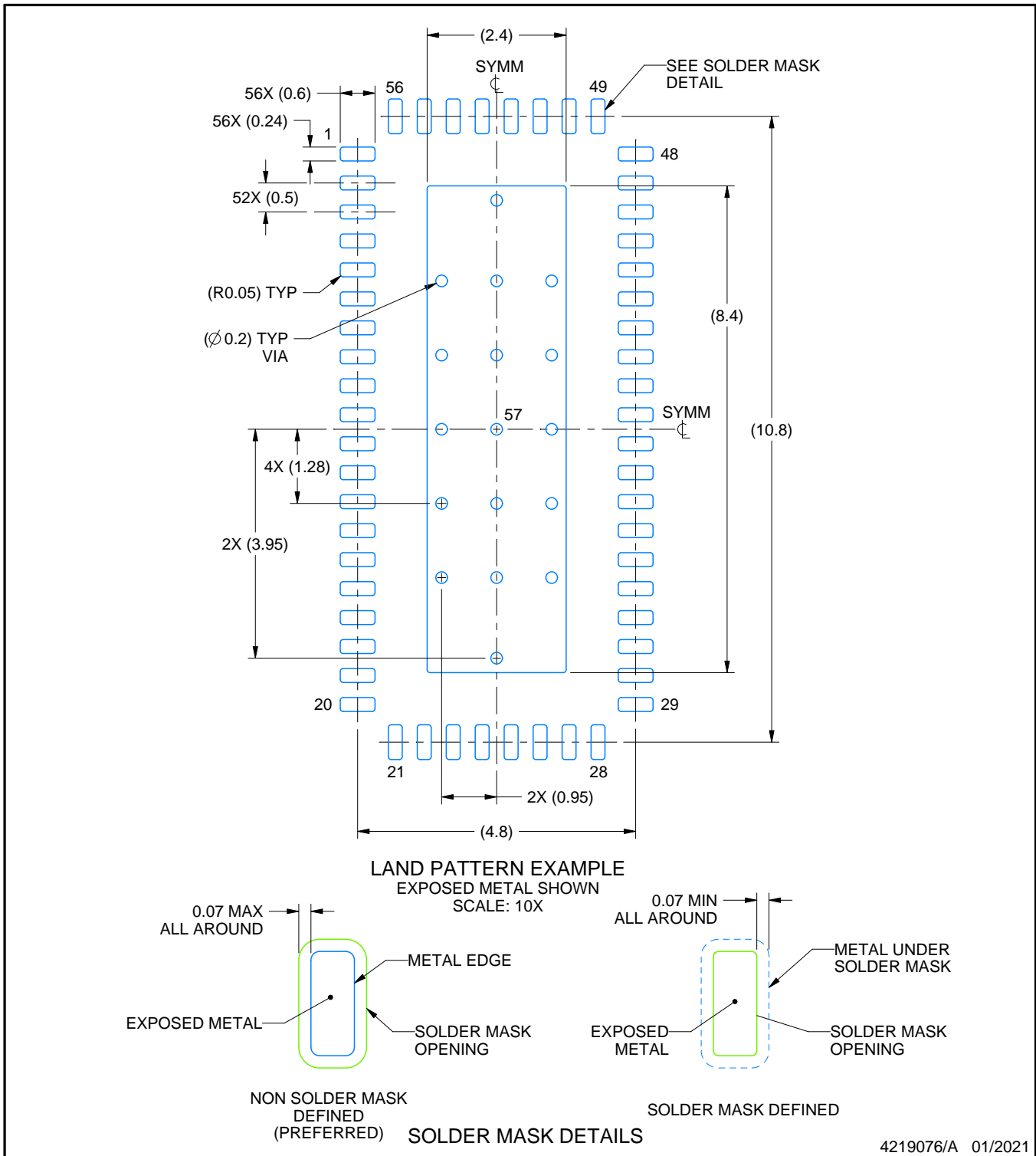

NOTES: (continued)

4. This package is designed to be soldered to a thermal pad on the board. For more information, see Texas Instruments literature number SLUA271 (www.ti.com/lit/slua271).
5. Vias are optional depending on application, refer to device data sheet. If any vias are implemented, refer to their locations shown on this view. It is recommended that vias under paste be filled, plugged or tented.

EXAMPLE STENCIL DESIGN

RHU0056A

WQFN - 0.8 mm max height

PLASTIC QUAD FLATPACK - NO LEAD

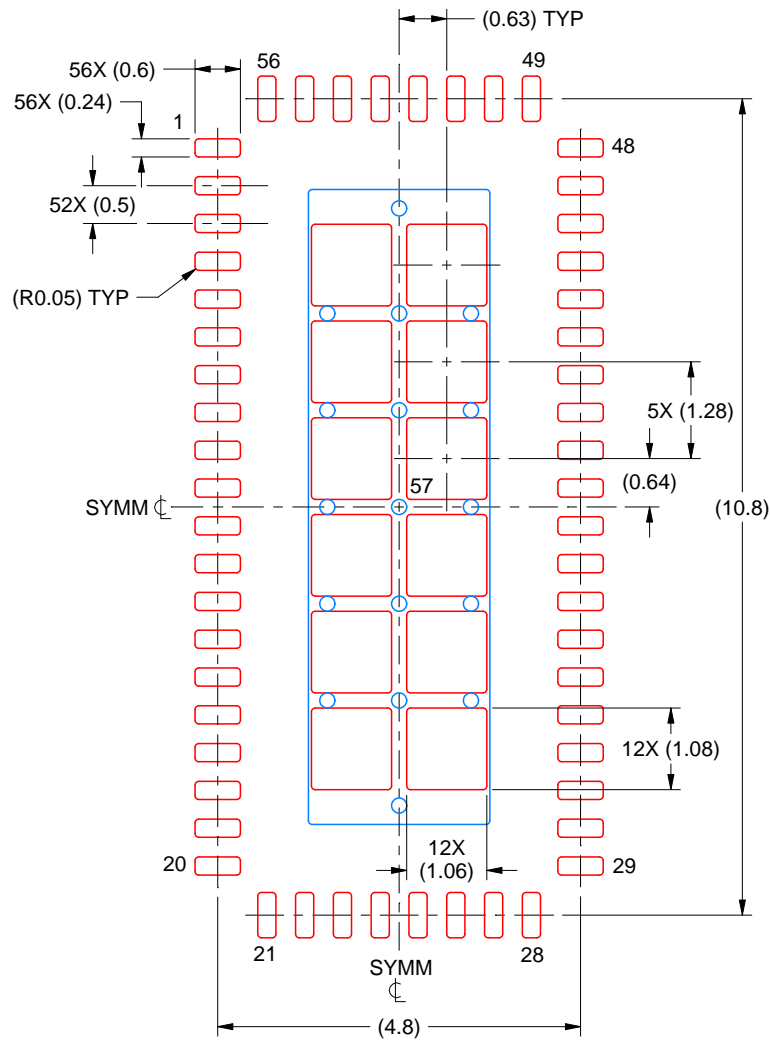

SOLDER PASTE EXAMPLE
BASED ON 0.125 MM THICK STENCIL
SCALE: 10X

EXPOSED PAD 57
68% PRINTED SOLDER COVERAGE BY AREA UNDER PACKAGE

4219076/A 01/2021

NOTES: (continued)

6. Laser cutting apertures with trapezoidal walls and rounded corners may offer better paste release. IPC-7525 may have alternate design recommendations.

重要なお知らせと免責事項

TI は、技術データと信頼性データ (データシートを含みます)、設計リソース (リファレンス・デザインを含みます)、アプリケーションや設計に関する各種アドバイス、Web ツール、安全性情報、その他のリソースを、欠陥が存在する可能性のある「現状のまま」提供しており、商品性および特定目的に対する適合性の黙示保証、第三者の知的財産権の非侵害保証を含むいかなる保証も、明示的または黙示的にかかわらず拒否します。

これらのリソースは、TI 製品を使用する設計の経験を積んだ開発者への提供を意図したものです。(1) お客様のアプリケーションに適した TI 製品の選定、(2) お客様のアプリケーションの設計、検証、試験、(3) お客様のアプリケーションに該当する各種規格や、その他のあらゆる安全性、セキュリティ、規制、または他の要件への確実な適合に関する責任を、お客様のみが単独で負うものとし、

上記の各種リソースは、予告なく変更される可能性があります。これらのリソースは、リソースで説明されている TI 製品を使用するアプリケーションの開発の目的でのみ、TI はその使用をお客様に許諾します。これらのリソースに関して、他の目的で複製することや掲載することは禁止されています。TI や第三者の知的財産権のライセンスが付与されている訳ではありません。お客様は、これらのリソースを自身で使用した結果発生するあらゆる申し立て、損害、費用、損失、責任について、TI およびその代理人を完全に補償するものとし、TI は一切の責任を拒否します。

TI の製品は、[TI の販売条件](#)、または [ti.com](#) やかかる TI 製品の関連資料などのいずれかを通じて提供する適用可能な条項の下で提供されています。TI がこれらのリソースを提供することは、適用される TI の保証または他の保証の放棄の拡大や変更を意味するものではありません。

お客様がいかなる追加条項または代替条項を提案した場合でも、TI はそれらに異議を唱え、拒否します。

郵送先住所 : Texas Instruments, Post Office Box 655303, Dallas, Texas 75265
Copyright © 2024, Texas Instruments Incorporated