

HD3SS3202 2チャンネル差動2:1/1:2 USB3.1マルチプレクサ/デマルチプレクサ

1 特長

- USB 3.1 Gen 1およびGen 2データ速度で、USB Type-C™エコシステム用のマルチプレクサ/デマルチプレクサ・ソリューションを提供
- MIPI DSI/CSI-2 DPHY、LVDS、PCIE Gen III、SATA Express、SATAと互換
- 最高10Gbpsで動作
- 8GHzを超える広い-3dB差動帯域幅
- 優れた動特性(5GHz時)
 - クロストーク = -41dB
 - オフ絶縁 = -20dB
 - 挿入損失 = -2.4dB
 - 反射損失 = -8dB
- 双方向「マルチプレクサ/デマルチプレクサ」差動スイッチ
- 0~2Vの同相電圧をサポート
- V_{CC} が3.3V±10%の単一電源
- 商業用温度範囲: 0°C~70°C (HD3SS3202)
- 工業用温度範囲: -40°C~85°C (HD3SS3202I)

2 アプリケーション

- USB Type-C™エコシステム
- デスクトップPCおよびノートPC
- 共有I/Oポート
- ドッキング・ステーション
- モニタ、テレビ
- セットトップ・ボックス
- ネットワーク・セキュリティ・カメラ

3 概要

HD3SS3202は、マルチプレクサまたはデマルチプレクサ構成の高速双方向パッシブ・スイッチで、USB 3.1 Gen 1およびGen 2データ速度をサポートするUSB Type-C™アプリケーションに適しています。このデバイスは制御ピンSELに従い、ポートBまたはポートCとポートAとの間で差動チャンネルのスイッチングを行います。

HD3SS3202は汎用のアナログ差動パッシブ・スイッチです。0~2Vの同相電圧範囲と、最大1800mVppの差動振幅での差動信号処理を必要とする、任意の高速インターフェイス・アプリケーションで動作します。このデバイスには適応型トラッキング機能があり、同相電圧範囲の全体にわたってチャンネルが変化せず維持されることを保証します。

このデバイスにより、信号のアイ・ダイアグラムへの減衰を最小限に抑え、追加のジッタもほとんどなしに、高速なスイッチングが可能になります。動作時の消費電力は1.65mW未満(標準値)です。OEnピンによるシャットダウン・モードがあり、シャットダウン時の消費電力は0.02μW未満(標準値)です。

製品情報⁽¹⁾

型番	パッケージ	本体サイズ(公称)
HD3SS3202	UQFN (16)	2.60mm×1.80mm
HD3SS3202I		

(1) 提供されているすべてのパッケージについては、巻末の注文情報を参照してください。

概略回路図

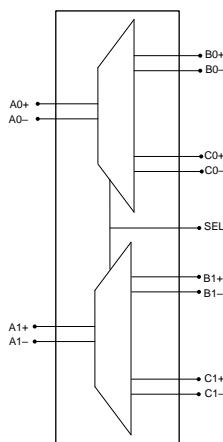

目次

1	特長	1	8.3	Feature Description	9
2	アプリケーション	1	8.4	Device Functional Modes	10
3	概要	1	9	Application and Implementation	11
4	改訂履歴	2	9.1	Application Information	11
5	Pin Configuration and Functions	3	9.2	Typical Applications	14
6	Specifications	4	9.3	Systems Examples	15
6.1	Absolute Maximum Ratings	4	10	Power Supply Recommendations	18
6.2	ESD Ratings	4	11	Layout	18
6.3	Recommended Operating Conditions	4	11.1	Layout Guidelines	18
6.4	Thermal Information	4	11.2	Layout Example	18
6.5	Electrical Characteristics	5	12	デバイスおよびドキュメントのサポート	19
6.6	High-Speed Performance Parameters	5	12.1	ドキュメントの更新通知を受け取る方法	19
6.7	Switching Characteristics	6	12.2	コミュニティ・リソース	19
6.8	Typical Characteristics	6	12.3	商標	19
7	Parameter Measurement Information	7	12.4	静電気放電に関する注意事項	19
8	Detailed Description	9	12.5	Glossary	19
8.1	Overview	9	13	メカニカル、パッケージ、および注文情報	19
8.2	Functional Block Diagram	9			

4 改訂履歴

資料番号末尾の英字は改訂を表しています。その改訂履歴は英語版に準じています。

2018年5月発行のものから更新

Page

•	Changed I_{CC} max from 0.6mA to 0.8mA	5
---	--	---

5 Pin Configuration and Functions

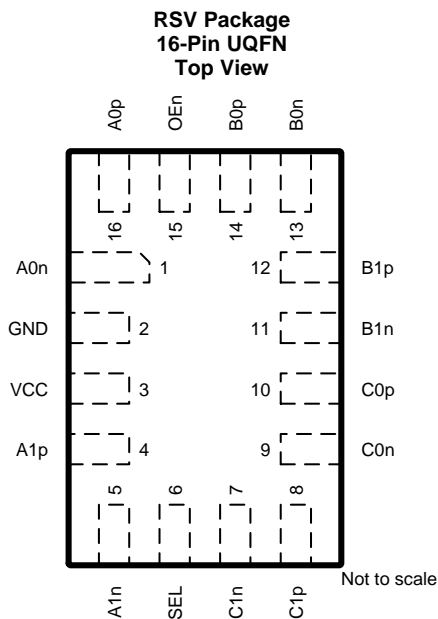

Pin Functions

PIN		I/O	DESCRIPTION
NAME	NO.		
A0n	1	I/O	Port A, channel 0, high-speed negative signal
GND	2	G	Ground
V _{CC}	3	P	3.3-V power
A1p	4	I/O	Port A, channel 1, high-speed positive signal
A1n	5	I/O	Port A, channel 1, high-speed negative signal
SEL	6	I	Port select pin. To help with noise immunity, a 0.01 μ F capacitor to GND on this pin is suggested. L: Port A to Port B H: Port A to Port C
C1n	7	I/O	Port C, channel 1, high-speed negative signal (connector side)
C1p	8	I/O	Port C, channel 1, high-speed positive signal (connector side)
C0n	9	I/O	Port C, channel 0, high-speed negative signal (connector side)
C0p	10	I/O	Port C, channel 0, high-speed positive signal (connector side)
B1n	11	I/O	Port B, channel 1, high-speed negative signal (connector side)
B1p	12	I/O	Port B, channel 1, high-speed positive signal (connector side)
B0n	13	I/O	Port B, channel 0, high-speed negative signal (connector side)
B0p	14	I/O	Port B, channel 0, high-speed positive signal (connector side)
OEn	15	I	Active-low chip enable. To help with noise immunity, a 0.01 μ F capacitor to GND on this pin is suggested. L: Normal operation H: Shutdown
A0p	16	I/O	Port A, channel 0, high-speed positive signal

6 Specifications

6.1 Absolute Maximum Ratings

 over operating free-air temperature range (unless otherwise noted)⁽¹⁾

			MIN	MAX	UNIT
V _{CC}	Supply voltage		-0.5	4	V
	Voltage	Differential I/O	-0.5	2.5	V
		Control pins	-0.5	V _{CC} + 0.5	
T _{stg}	Storage temperature		-65	150	°C

(1) Stresses beyond those listed under *Absolute Maximum Ratings* may cause permanent damage to the device. These are stress ratings only, which do not imply functional operation of the device at these or any other conditions beyond those indicated under *Recommended Operating Conditions*. Exposure to absolute-maximum-rated conditions for extended periods may affect device reliability.

6.2 ESD Ratings

			VALUE	UNIT
V _(ESD)	Electrostatic discharge	Human-body model (HBM), per ANSI/ESDA/JEDEC JS-001 ⁽¹⁾	±2000	V
		Charged-device model (CDM), per JEDEC specification JESD22-C101 ⁽²⁾	±500	

(1) JEDEC document JEP155 states that 500-V HBM allows safe manufacturing with a standard ESD control process.

(2) JEDEC document JEP157 states that 250-V CDM allows safe manufacturing with a standard ESD control process.

6.3 Recommended Operating Conditions

over operating free-air temperature range (unless otherwise noted)

			MIN	NOM	MAX	UNIT
V _{CC}	Supply voltage		3	3.3	3.6	V
V _{ih}	Input high voltage (SEL, OEn pins)		2		V _{CC}	V
V _{il}	Input low voltage (SEL, OEn pins)		-0.1		0.8	V
V _{diff}	High-speed signal pins differential voltage		0		1.8	V _{pp}
V _{cm}	High speed signal pins common mode voltage		0		2	V
T _A	Operating free-air/ambient temperature	HD3SS3202RSV	0		70	°C
		HD3SS3202IRSV	-40		85	

6.4 Thermal Information

THERMAL METRIC ⁽¹⁾		HD3SS3202	UNIT
		RSV (VQFN)	
		16 PINS	
R _{θJA}	Junction-to-ambient thermal resistance	117.3	°C/W
R _{θJC(top)}	Junction-to-case (top) thermal resistance	52.1	°C/W
R _{θJB}	Junction-to-board thermal resistance	52.6	°C/W
ψ _{JT}	Junction-to-top characterization parameter	1.2	°C/W
ψ _{JB}	Junction-to-board characterization parameter	51.1	°C/W
R _{θJC(bot)}	Junction-to-case (bottom) thermal resistance	n/a	°C/W

(1) For more information about traditional and new thermal metrics, see the [Semiconductor and IC Package Thermal Metrics](#) application report.

6.5 Electrical Characteristics

over operating free-air temperature range (unless otherwise noted)

PARAMETER		TEST CONDITIONS	MIN	TYP	MAX	UNIT
I_{CC}	Device active current	$V_{CC} = 3.3\text{ V}$, $OEN = 0$		0.5	0.8	mA
I_{STDN}	Device shutdown current	$V_{CC} = 3.3\text{ V}$, $OEN = V_{CC}$		0.005	1	μA
C_{ON}	Output ON capacitance to GND			0.6		pF
C_{OFF}	Output OFF capacitance to GND			0.8		pF
R_{ON}	Output ON resistance	$V_{CC} = 3.3\text{ V}$; $V_{CM} = 0\text{ to }2\text{ V}$; $I_O = -8\text{ mA}$		5	8	Ω
ΔR_{ON}	On-resistance match between pairs of the same channel	$V_{CC} = 3.3\text{ V}$; $-0.35\text{ V} \leq V_{IN} \leq 2.35\text{ V}$; $I_O = -8\text{ mA}$			0.7	Ω
R_{FLAT_ON}	On-resistance flatness $R_{ON}(MAX) - R_{ON}(MIN)$	$V_{CC} = 3.3\text{ V}$; $-0.35\text{ V} \leq V_{IN} \leq 2.35\text{ V}$			1	Ω
$I_{IH,CTRL}$	Input high current, control pins (SEL, OEn)				1	μA
$I_{IL,CTRL}$	Input low current, control pins (SEL, OEn)				1	μA
$I_{IH,HS}$	Input high current, high-speed pins [Ax/Bx/Cx][p/n]	$V_{IN} = 2\text{ V}$ for selected port, A and B with SEL = 0, and A and C with SEL = V_{CC}			1	μA
$I_{IH,HS}$	Input high current, high-speed pins [Ax/Bx/Cx][p/n]	$V_{IN} = 2\text{ V}$ for non-selected port, C with SEL = 0, and B with SEL = V_{CC} ⁽¹⁾		100	140	μA
$I_{IL,HS}$	Input low current, high-speed pins [Ax/Bx/Cx][p/n]				1	μA

(1) There is a 20-k Ω pull-down in non-selected port.

6.6 High-Speed Performance Parameters

PARAMETER	TEST CONDITION	MIN	TYP	MAX	UNIT
I_L	Differential insertion loss	$f = 0.3\text{ MHz}$		-0.4	dB
		$f = 0.625\text{ MHz}$		-0.4	
		$f = 2.5\text{ GHz}$		-1.3	
		$f = 4\text{ GHz}$		-2.0	
		$f = 5\text{ GHz}$		-2.4	
BW	-3-dB bandwidth		8		GHz
R_L	Differential return loss	$f = 0.3\text{ MHz}$		-27	dB
		$f = 2.5\text{ GHz}$		-11	
		$f = 4\text{ GHz}$		-9	
		$f = 5\text{ GHz}$		-8	
O_{IRR}	Differential OFF isolation	$f = 0.3\text{ MHz}$		-77	dB
		$f = 2.5\text{ GHz}$		-23	
		$f = 4\text{ GHz}$		-21	
		$f = 5\text{ GHz}$		-20	
X_{TALK}	Differential crosstalk	$f = 0.3\text{ MHz}$		-82	dB
		$f = 2.5\text{ GHz}$		-44	
		$f = 4\text{ GHz}$		-41	
		$f = 5\text{ GHz}$		-41	

6.7 Switching Characteristics

PARAMETER		MIN	TYP	MAX	UNIT
t _{PD}	Switch propagation delay (see 4)			80	ps
t _{SW_ON}	Switching time SEL-to-Switch ON (see 3)			0.5	μs
t _{SW_OFF}	Switching time SEL-to-Switch OFF (see 3)			0.5	μs
t _{SK_INTRA}	Intra-pair output skew (see 4)			6	ps
t _{SK_INTER}	Inter-pair output skew (see 4)			20	ps
t _{PD}	Average propagation delay, see 1	f = 100 MHz	16	54	ps
		f = 200 MHz	33	63	
		f = 300 MHz	33	59	
		f = 400 MHz	33	57	
		f = 500 MHz	33	56	
		f = 600 MHz	33	53	
		f = 700 MHz	33	50	
		f = 750 MHz	33	50	
		f = 800 MHz	33	50	
		f = 900 MHz	31	50	
		f = 1000 MHz	30	50	

6.8 Typical Characteristics

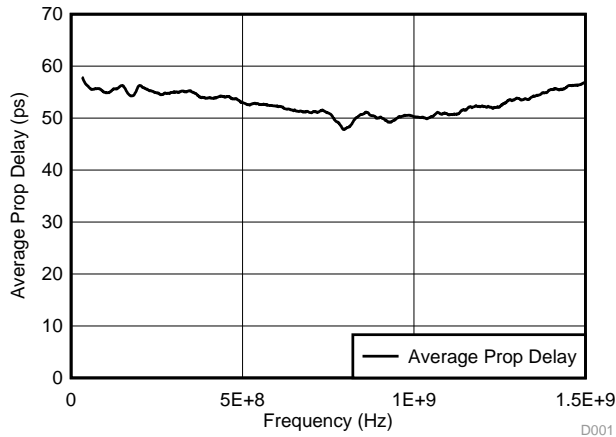

1. Average Propagation Delay vs Frequency

7 Parameter Measurement Information



图 2. Test Setup



图 3. Switch On and Off Timing Diagram

Parameter Measurement Information (continued)

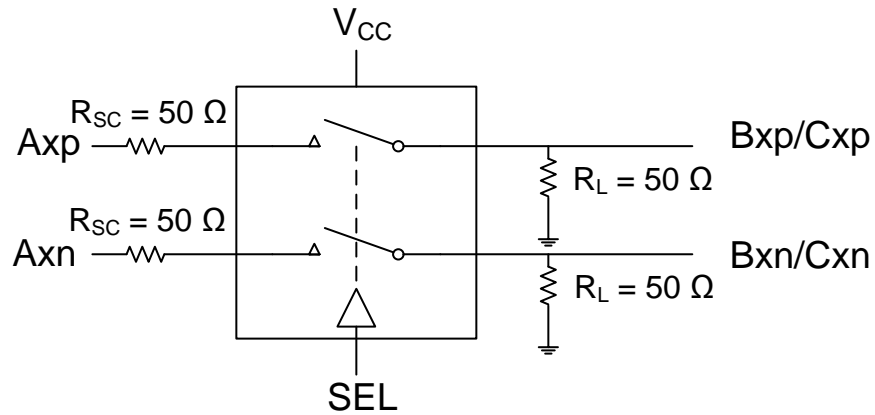

图 4. Timing Diagrams and Test Setup

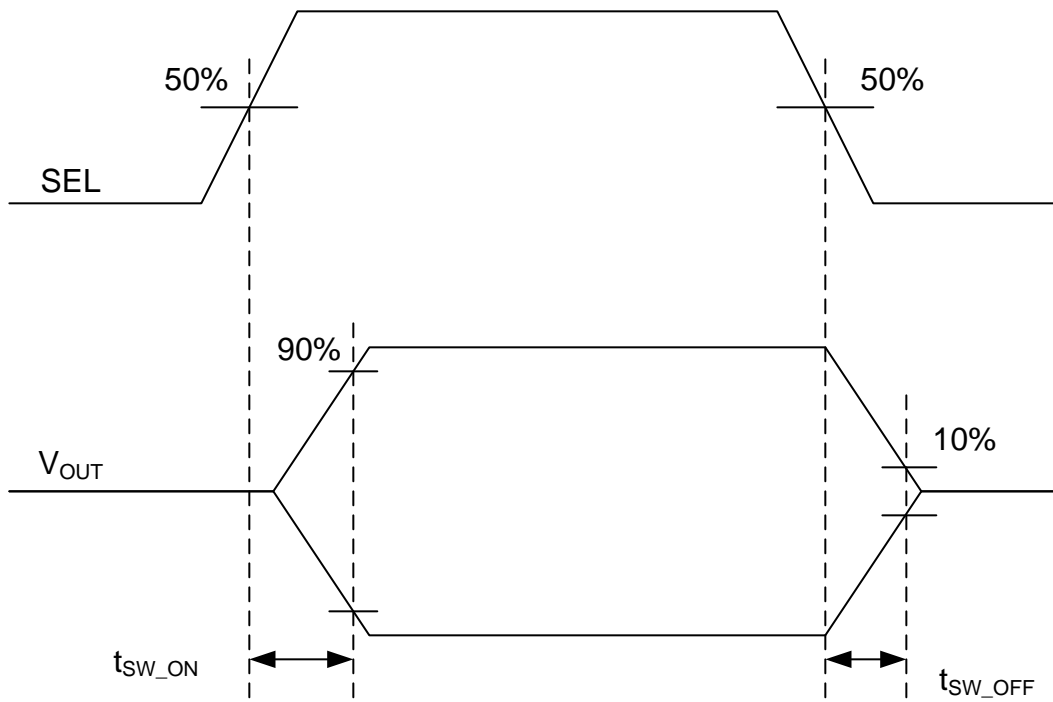
8 Detailed Description

8.1 Overview

The HD3SS3202 is a generic analog differential passive switch that can work for any high-speed interface applications requiring a common mode voltage range of 0 to 2 V and differential signaling with differential amplitude up to 1800 mVpp. It uses adaptive tracking to ensure the channel remains unchanged for the entire common mode voltage range.

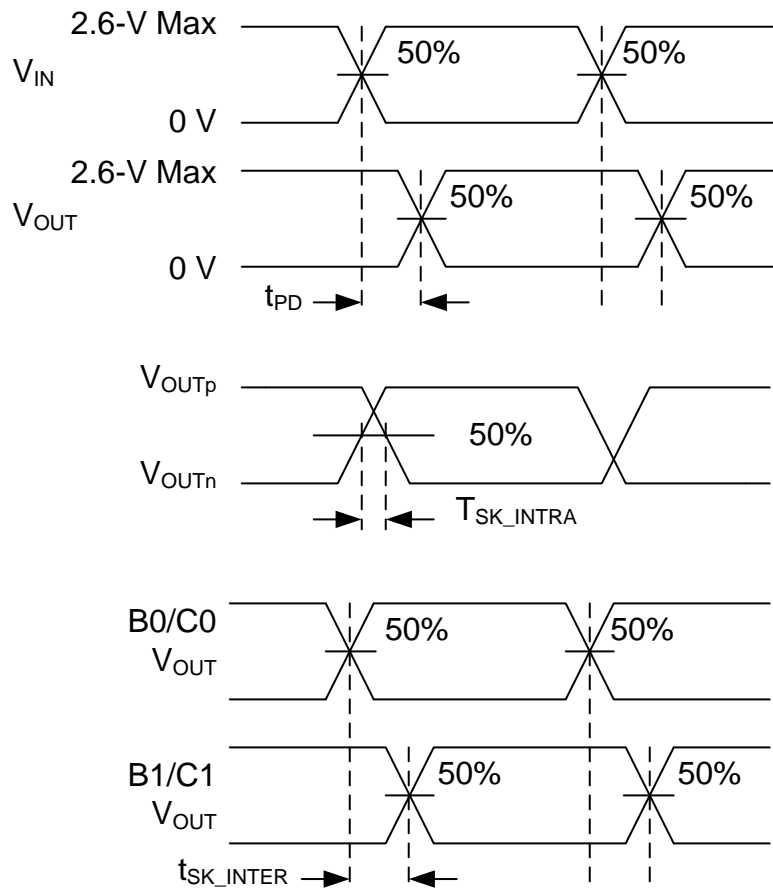
Excellent dynamic characteristics of the device allow high-speed switching with minimum attenuation to the signal eye diagram with little added jitter. It consumes < 1.65 mW (typ) of power when operational and has a shutdown mode exercisable by OEn pin resulting in < .02 μ W (typical).

8.2 Functional Block Diagram

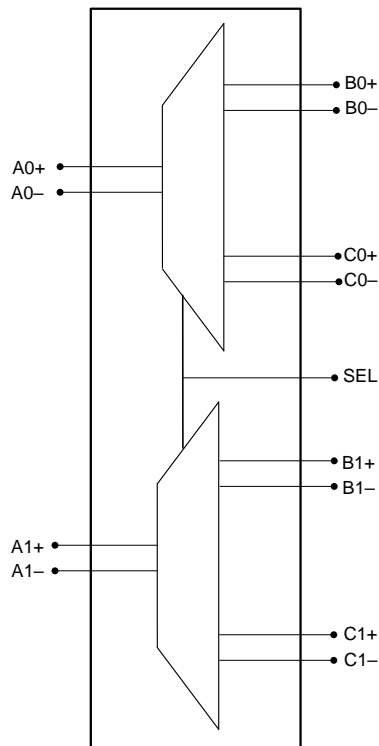

8.3 Feature Description

8.3.1 Output Enable and Power Savings

The HD3SS3202 has two power modes, active/normal operating mode and standby/shutdown mode. During standby mode, the device consumes little current to save the maximum power. To enter standby mode, the OEn control pin is pulled high through a resistor and must remain high. For active/normal operation, the OEn control pin should be pulled low to GND.

HD3SS3202 consumes < 1.65 mW (typ) of power when operational and has a shutdown mode exercisable by the OEn pin resulting in < .02 μ W (typ).

8.4 Device Functional Modes

表 1. Port Select Control Logic⁽¹⁾

PORT A CHANNEL	PORT B OR PORT C CHANNEL CONNECTED TO PORT A CHANNEL	
	SEL = L	SEL = H
A0p	B0p	C0p
A0n	B0n	C0n
A1p	B1p	C1p
A1n	B1n	C1n

- (1) The HD3SS3202 can tolerate polarity inversions for all differential signals on Ports A, B, and C. Take care to ensure the same polarity is maintained on Port A versus Ports B/C.

9 Application and Implementation

注

Information in the following applications sections is not part of the TI component specification, and TI does not warrant its accuracy or completeness. TI's customers are responsible for determining suitability of components for their purposes. Customers should validate and test their design implementation to confirm system functionality.

9.1 Application Information

The HD3SS3202 is a generic 2-channel high-speed mux/demux type of switch that can be used for routing high-speed signals between two different locations on a circuit board. The HD3SS3202 supports several high-speed data protocols with a differential amplitude of <math><1800\text{ mVpp}</math> and a common mode voltage of <math><2\text{ V}</math>, as with USB 3.1 and DisplayPort 1.2. The device has one select input (SEL) pin that can be controlled by an available GPIO pin within a system or from a microcontroller.

The HD3SS3202 with its adaptive common mode tracking technology can support applications where the common mode is different between the RX and TX pair. The two USB3.1 Type C connector applications show both a host and device side. The cable between the two connectors swivels the pairs to properly route the signals to the correct pin. The other applications are more generic because different connectors can be used.

Many interfaces require AC coupling between the transmitter and receiver. The 0201 capacitors are the preferred option to provide AC coupling; 0402 size capacitors also work. Avoid the capacitors greater than 0402 and C-packs. When placing AC coupling capacitors, symmetric placement is best. The designer should place them along the TX pairs on the system board, which are usually routed on the top layer of the board.

The AC coupling capacitors have several placement options. Because the HD3SS3202 requires a bias voltage, the designer must place the capacitors on one side of the switch. If they are placed on both sides of the switch, a biasing voltage should be provided. Figure 5 shows a few placement options. The coupling capacitors are placed between the HD3SS3202 and endpoint.



图 5. AC Coupling Capacitors between HD3SS3202 TX and Endpoint TX

Application Information (continued)

In [Figure 6](#), the coupling capacitors are placed on the host transmit pair and endpoint transmit pair. In this situation, the switch on top is biased by the endpoint and the lower switch is biased by the host controller.

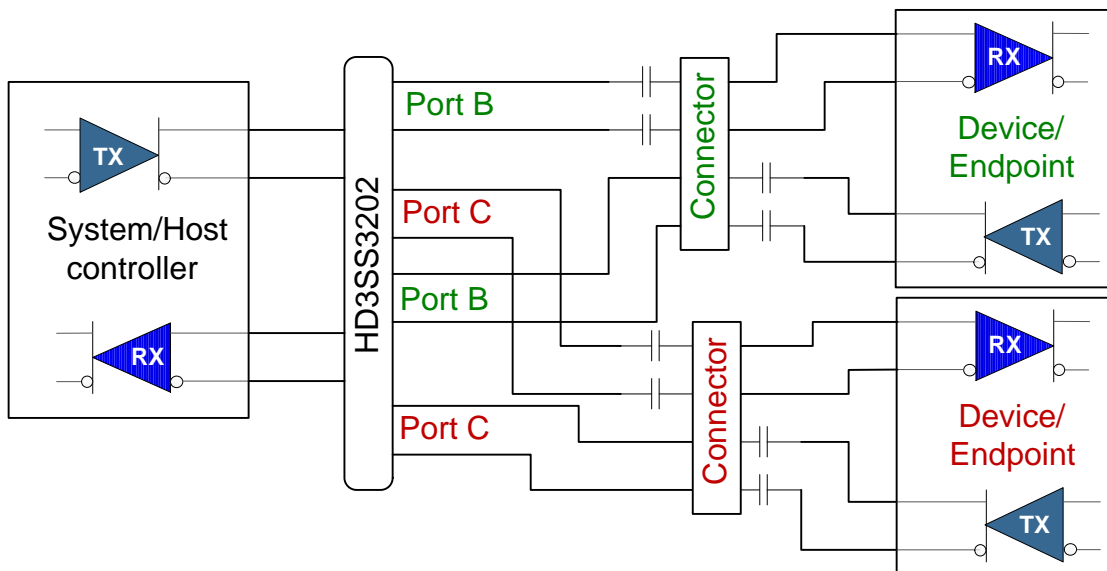
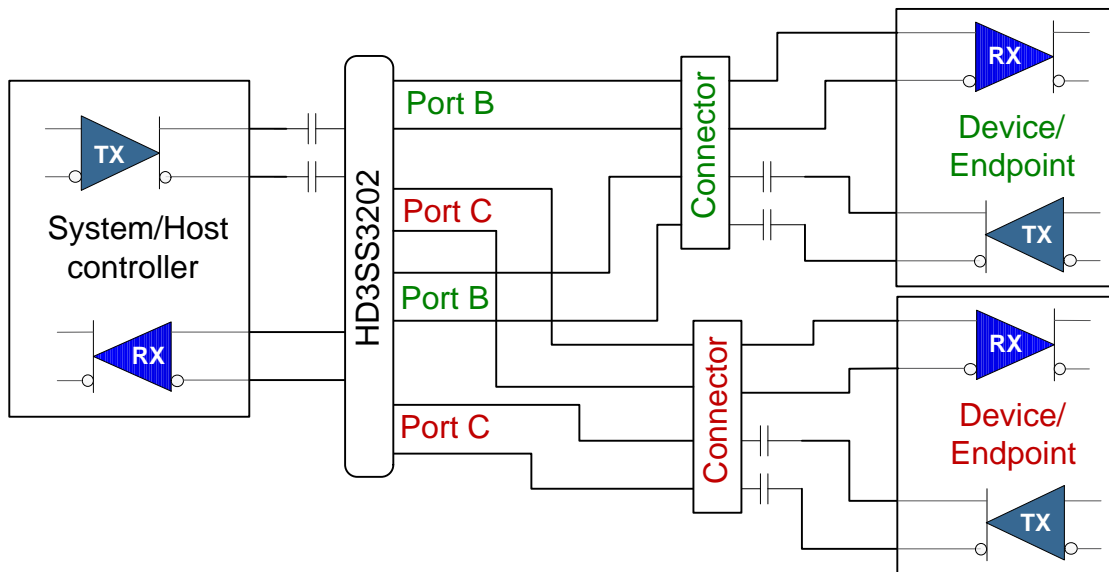
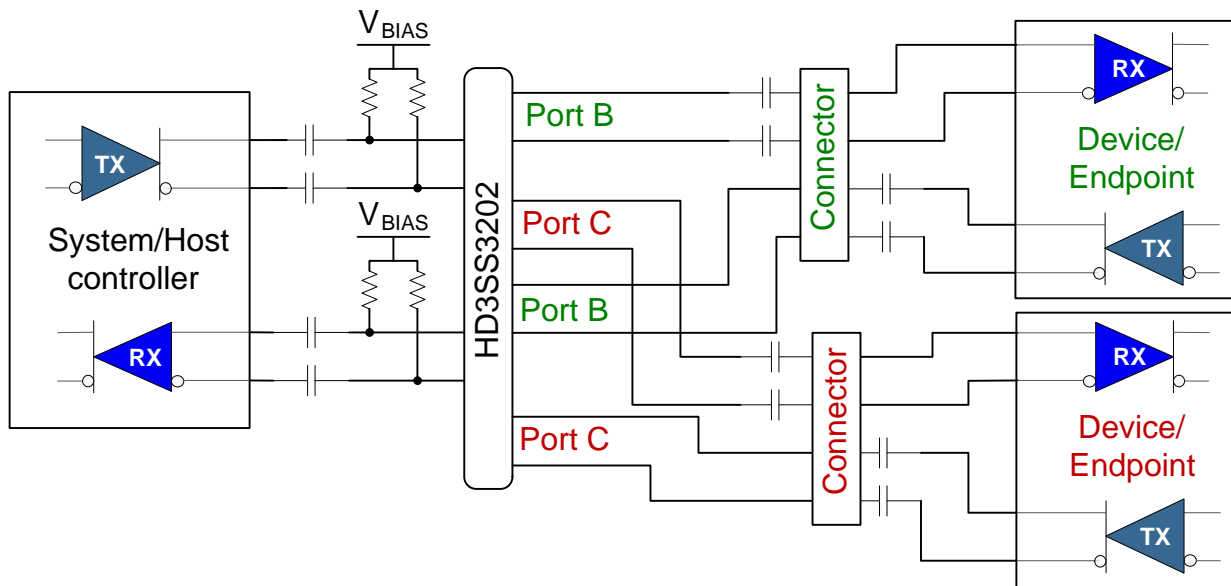

Figure 6. AC Coupling Capacitors on Host TX and Endpoint TX

If the common mode voltage in the system is higher than 2 V, the coupling capacitors are placed on both sides of the switch (shown in [Figure 7](#)). A biasing voltage of < 2 V is required in this case.



V_{BIAS} can be GND

Capacitor and resistor values depend upon application.

Figure 7. AC Coupling Capacitors on Both Sides of Switch

Application Information (continued)

The HD3SS3202 can be used with the USB Type C connector to support the connector's flip ability. [Figure 8](#) provides the generic location for the AC coupling capacitors for this application.

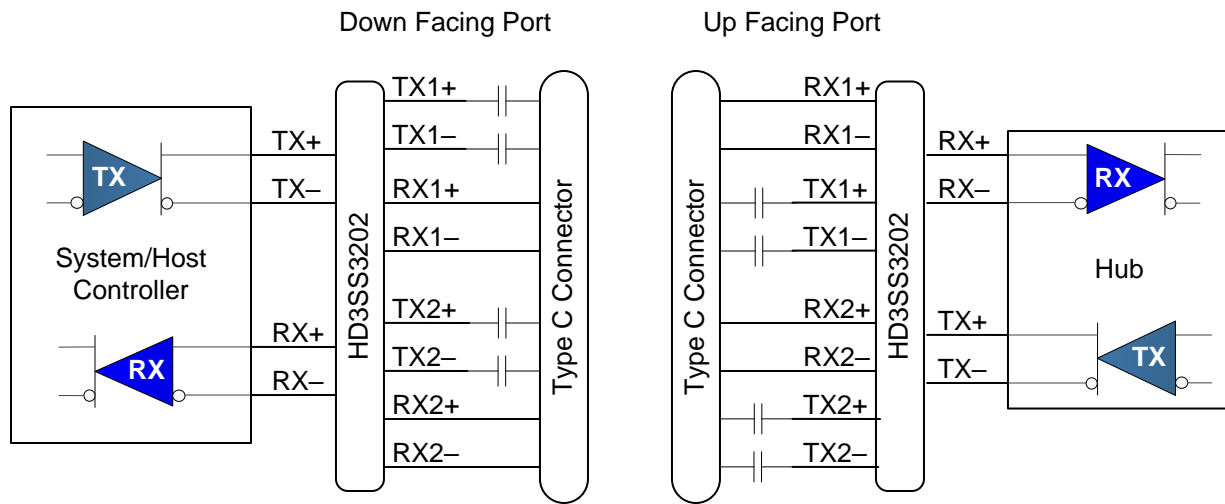

Figure 8. AC Coupling Capacitors for USB Type C

9.2 Typical Applications

9.2.1 Down Facing Port for USB3.1 Type C



图 9. Down Facing Port for USB3.1 Type C Connector

9.2.1.1 Design Requirements

The HD3SS3202 can be designed into many different applications. All the applications have certain requirements for the system to work properly. The HD3SS3202 requires 3.3-V $\pm 10\%$ V_{CC} rail. The OEn pin must be low for device to work; otherwise, it disables the outputs. This pin can be driven by a processor. The expectation is that one side of the device has AC coupling capacitors. 表 2 provides information on expected values to perform properly.

表 2. Design Parameters

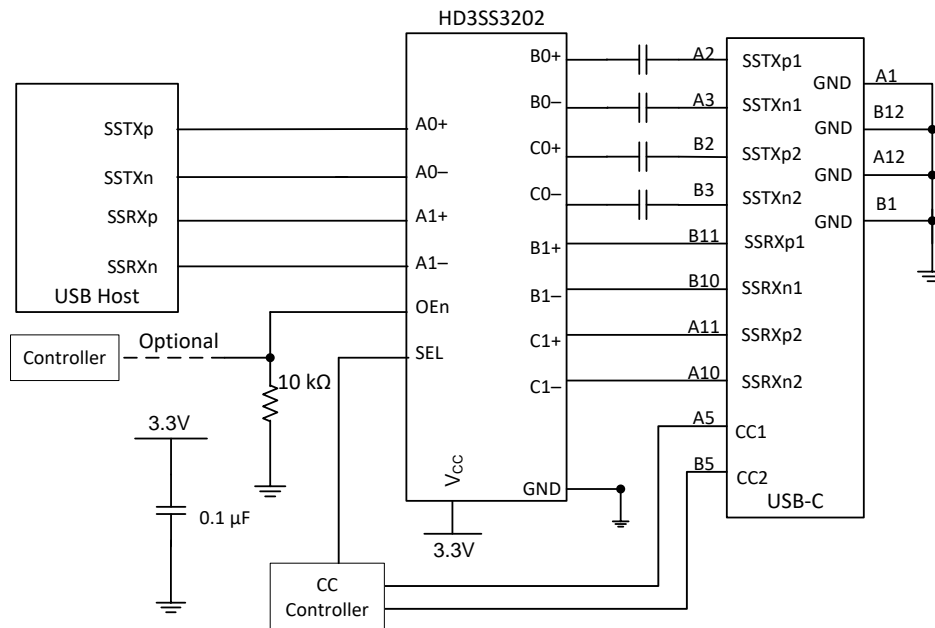
DESIGN PARAMETER	VALUE
V_{CC}	3.3 V
AXp/n, BXp/n, CXp/n CM input voltage	0 to 2 V
Control/OEn pin max voltage for low	0.8 V
Control/OEn pin min voltage for high	2.0 V
AC coupling capacitor	75 nF to 265 nF.
R_{BIAS} (图 9) when needed	100 kΩ

9.2.1.2 Detailed Design Procedure

The HD3SS3202 is a high-speed passive switch device that can behave as a mux or demux. Because this is a passive switch, signal integrity is important because the device provides no signal conditioning capability. The device can support 1 to 2 inches of board trace and a connector on either end.

To design in the HD3SS3202, the designer needs to understand the following.

- Determine the loss profile between circuits that are to be muxed or demuxed.
- Provide clean impedance and electrical length matched board traces.
- Depending upon the application, determine the best place to put the 100-nF coupling capacitor.
- Provide a control signal for the SEL and OEn pins. It may be necessary to include a 0.01 μ F to GND on each of these pins to help with noise immunity.
- See the application schematics on recommended decouple capacitors from V_{CC} pins to ground

9.2.1.3 Application Curves

Figure 10 shows the eye at the input of the HD3SS3202 and Figure 11 at the output of the HD3SS3202.

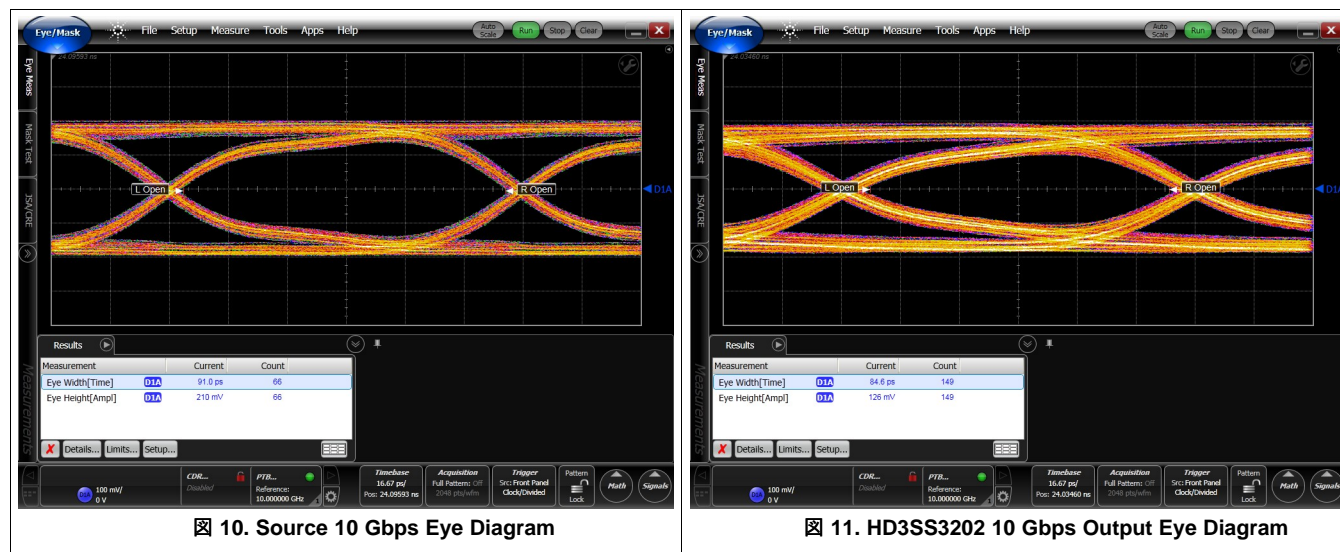

9.3 Systems Examples

9.3.1 Up Facing Port for USB3.1 Type C

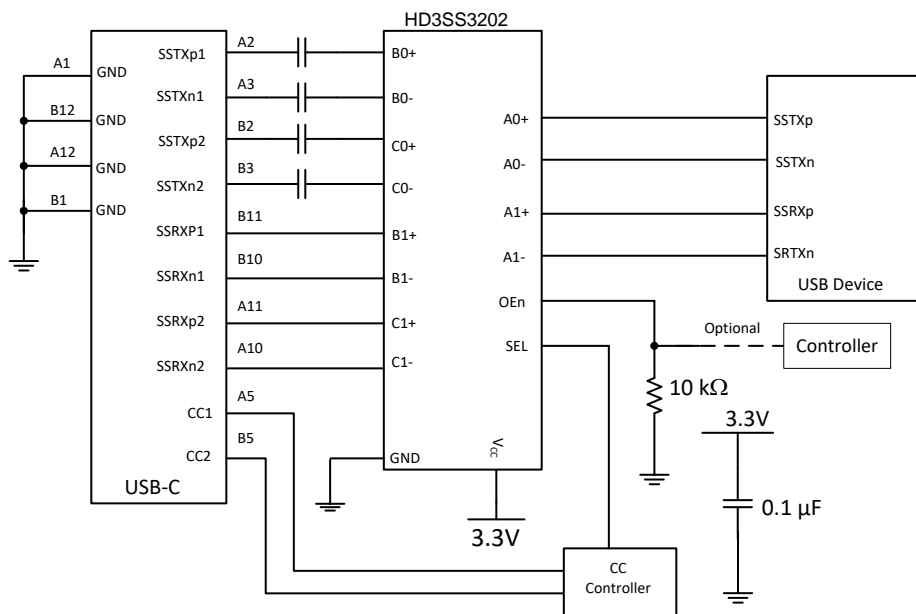
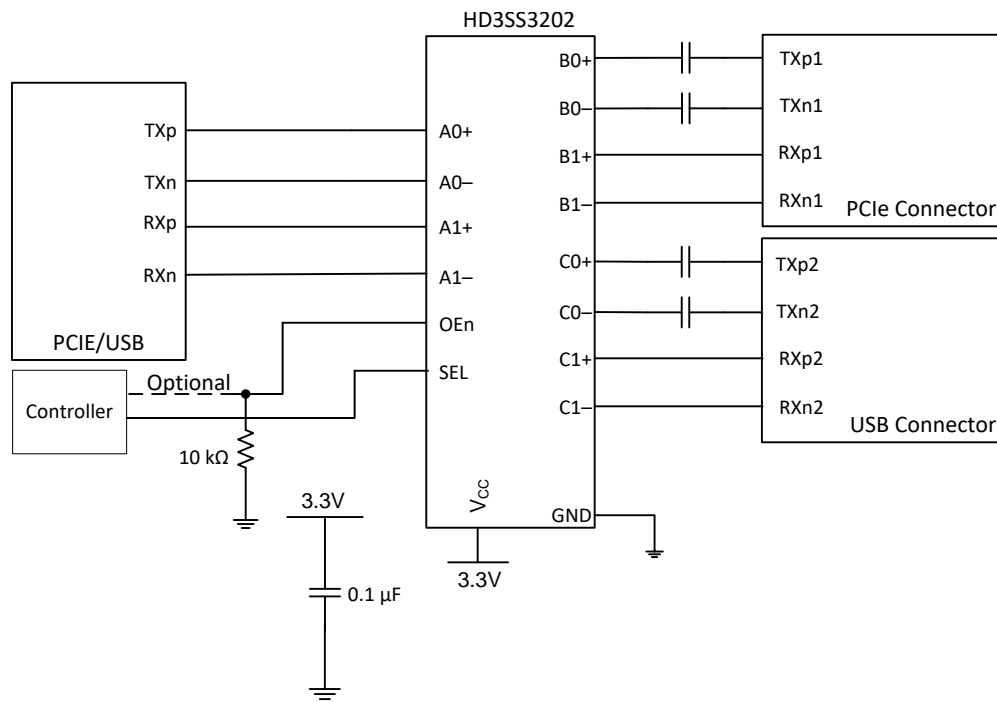

Figure 12. Up Facing Port for USB3.1 USB Type-C Connector

Systems Examples (continued)

9.3.2 PCIE/USB



13. PCIE Motherboard

9.3.3 PCIE/eSATA

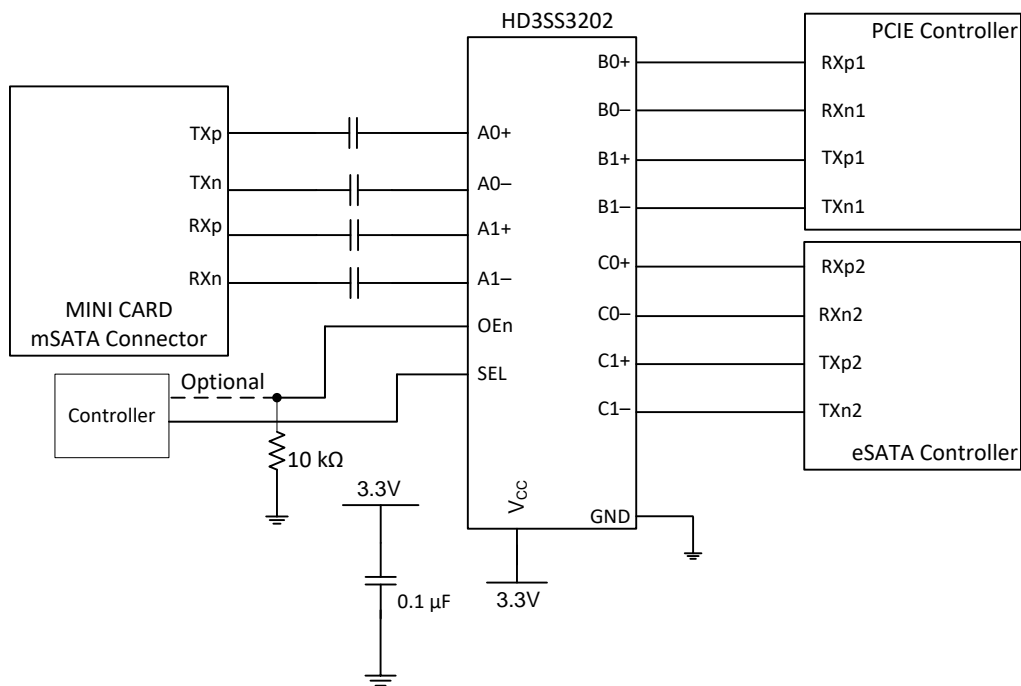

14. PCIE and eSATA Combo

Systems Examples (continued)

9.3.4 USB/eSATA

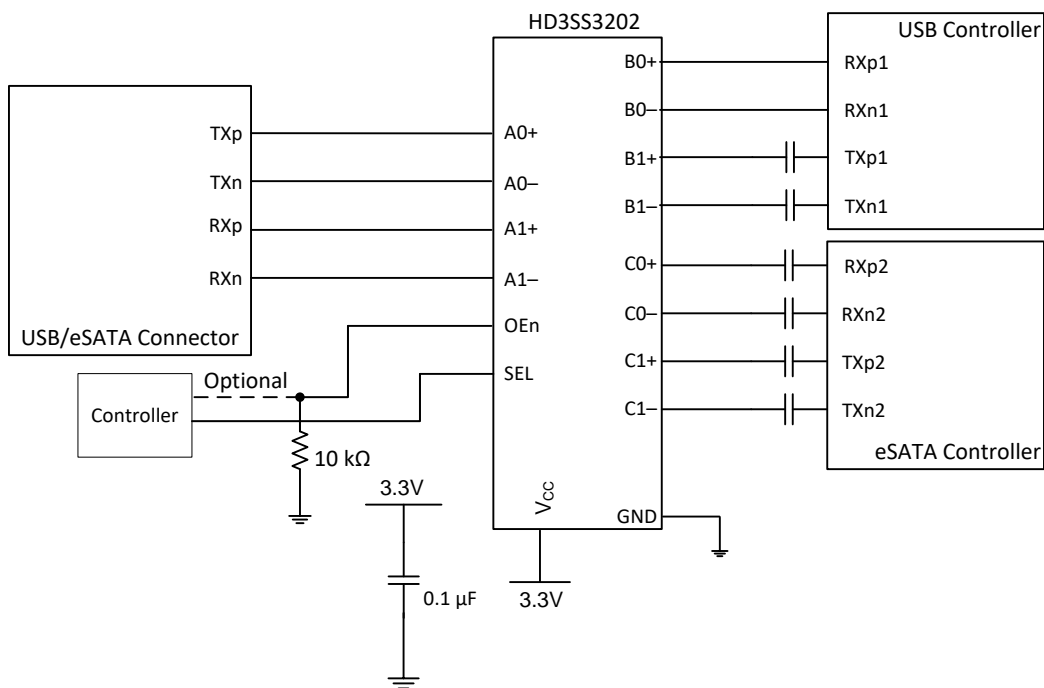

15. eSATA and USB 3.1 Combo Connector

9.3.5 MIPI Camera Serial Interface

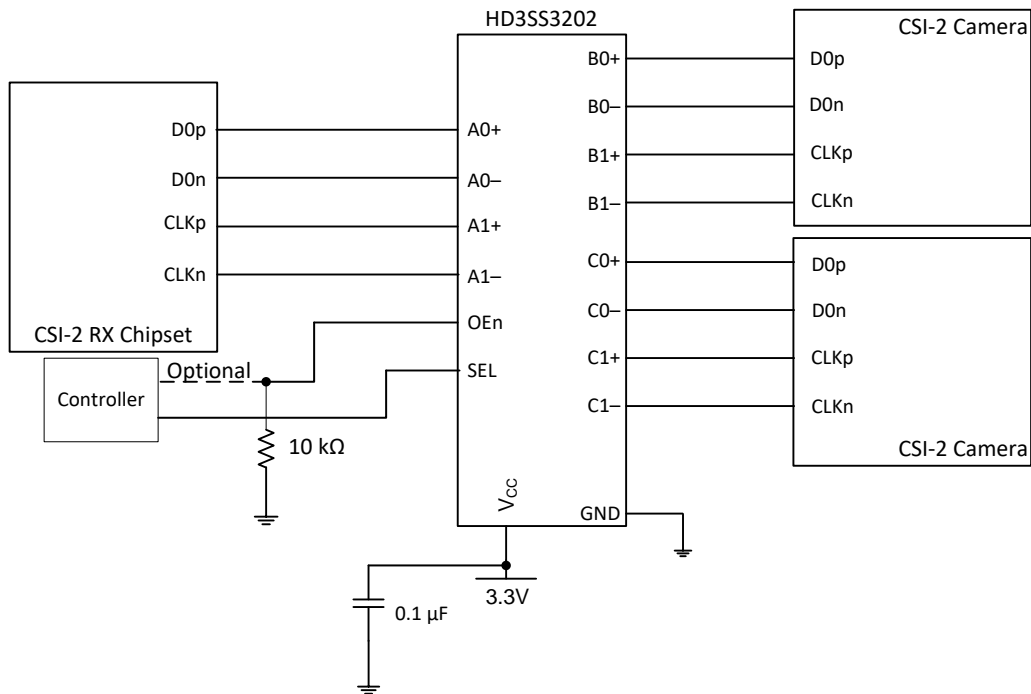

16. CSI Camera Array

10 Power Supply Recommendations

The HD3SS3202 does not require a power supply sequence. TI recommends placing a 100nF de-coupling capacitor at the device V_{CC} near the pin.

11 Layout

11.1 Layout Guidelines

11.2 Layout Example

Example 4 layer PCB Stackup

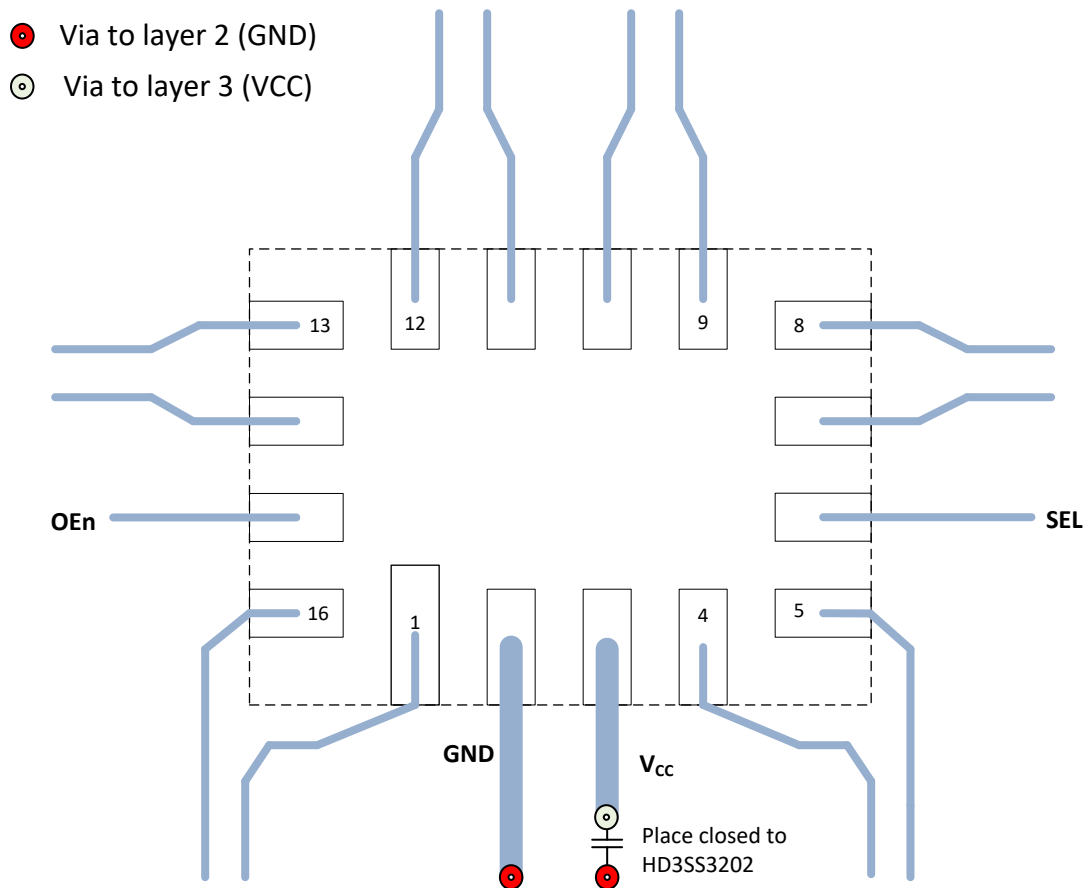
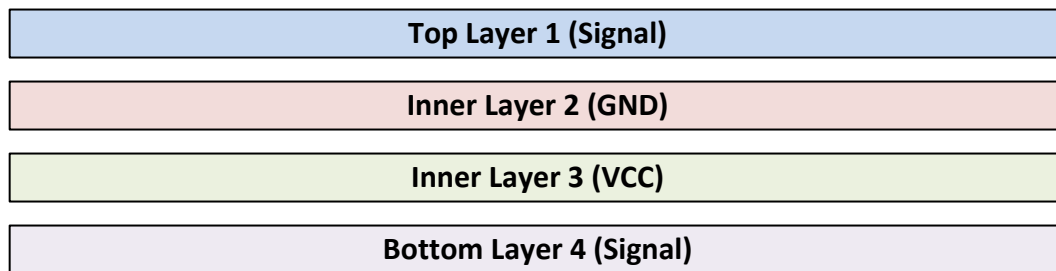

Copyright © 2018, Texas Instruments Incorporated

Figure 17. HD3SS3202 Basic Layout Example

12 デバイスおよびドキュメントのサポート

12.1 ドキュメントの更新通知を受け取る方法

ドキュメントの更新についての通知を受け取るには、ti.comのデバイス製品フォルダを開いてください。右上の隅にある「通知を受け取る」をクリックして登録すると、変更されたすべての製品情報に関するダイジェストを毎週受け取れます。変更の詳細については、修正されたドキュメントに含まれている改訂履歴をご覧ください。

12.2 コミュニティ・リソース

The following links connect to TI community resources. Linked contents are provided "AS IS" by the respective contributors. They do not constitute TI specifications and do not necessarily reflect TI's views; see TI's [Terms of Use](#).

TI E2E™オンライン・コミュニティ *TIのE2E (Engineer-to-Engineer) コミュニティ*。エンジニア間の共同作業を促進するために開設されたものです。e2e.ti.comでは、他のエンジニアに質問し、知識を共有し、アイデアを検討して、問題解決に役立てることができます。

設計サポート *TIの設計サポート* 役に立つE2Eフォーラムや、設計サポート・ツールをすばやく見つけることができます。技術サポート用の連絡先情報も参照できます。

12.3 商標

E2E is a trademark of Texas Instruments.

12.4 静電気放電に関する注意事項



すべての集積回路は、適切なESD保護方法を用いて、取扱いと保存を行うようにして下さい。

静電気放電はわずかな性能の低下から完全なデバイスの故障に至るまで、様々な損傷を与えます。高精度の集積回路は、損傷に対して敏感であり、極めてわずかなパラメータの変化により、デバイスに規定された仕様に適合しなくなる場合があります。

12.5 Glossary

SLYZ022 — *TI Glossary*.

This glossary lists and explains terms, acronyms, and definitions.

13 メカニカル、パッケージ、および注文情報

以降のページには、メカニカル、パッケージ、および注文に関する情報が記載されています。この情報は、そのデバイスについて利用可能な最新のデータです。このデータは予告なく変更されることがあり、ドキュメントが改訂される場合もあります。本データシートのブラウザ版を使用されている場合は、画面左側の説明をご覧ください。

PACKAGING INFORMATION

Orderable Device	Status (1)	Package Type	Package Drawing	Pins	Package Qty	Eco Plan (2)	Lead finish/ Ball material (6)	MSL Peak Temp (3)	Op Temp (°C)	Device Marking (4/5)	Samples
HD3SS3202IRSVR	ACTIVE	UQFN	RSV	16	3000	RoHS & Green	NIPDAU	Level-1-260C-UNLIM	-40 to 85	3202	Samples
HD3SS3202IRSVT	ACTIVE	UQFN	RSV	16	250	RoHS & Green	NIPDAU	Level-1-260C-UNLIM	-40 to 85	3202	Samples
HD3SS3202RSVR	ACTIVE	UQFN	RSV	16	3000	RoHS & Green	NIPDAU	Level-1-260C-UNLIM	0 to 70	3202	Samples
HD3SS3202RSVT	ACTIVE	UQFN	RSV	16	250	RoHS & Green	NIPDAU	Level-1-260C-UNLIM	0 to 70	3202	Samples

(1) The marketing status values are defined as follows:

ACTIVE: Product device recommended for new designs.

LIFEBUY: TI has announced that the device will be discontinued, and a lifetime-buy period is in effect.

NRND: Not recommended for new designs. Device is in production to support existing customers, but TI does not recommend using this part in a new design.

PREVIEW: Device has been announced but is not in production. Samples may or may not be available.

OBSELETE: TI has discontinued the production of the device.

(2) **RoHS:** TI defines "RoHS" to mean semiconductor products that are compliant with the current EU RoHS requirements for all 10 RoHS substances, including the requirement that RoHS substance do not exceed 0.1% by weight in homogeneous materials. Where designed to be soldered at high temperatures, "RoHS" products are suitable for use in specified lead-free processes. TI may reference these types of products as "Pb-Free".

RoHS Exempt: TI defines "RoHS Exempt" to mean products that contain lead but are compliant with EU RoHS pursuant to a specific EU RoHS exemption.

Green: TI defines "Green" to mean the content of Chlorine (Cl) and Bromine (Br) based flame retardants meet JS709B low halogen requirements of <=1000ppm threshold. Antimony trioxide based flame retardants must also meet the <=1000ppm threshold requirement.

(3) MSL, Peak Temp. - The Moisture Sensitivity Level rating according to the JEDEC industry standard classifications, and peak solder temperature.

(4) There may be additional marking, which relates to the logo, the lot trace code information, or the environmental category on the device.

(5) Multiple Device Markings will be inside parentheses. Only one Device Marking contained in parentheses and separated by a "-" will appear on a device. If a line is indented then it is a continuation of the previous line and the two combined represent the entire Device Marking for that device.

(6) Lead finish/Ball material - Orderable Devices may have multiple material finish options. Finish options are separated by a vertical ruled line. Lead finish/Ball material values may wrap to two lines if the finish value exceeds the maximum column width.

Important Information and Disclaimer:The information provided on this page represents TI's knowledge and belief as of the date that it is provided. TI bases its knowledge and belief on information provided by third parties, and makes no representation or warranty as to the accuracy of such information. Efforts are underway to better integrate information from third parties. TI has taken and

continues to take reasonable steps to provide representative and accurate information but may not have conducted destructive testing or chemical analysis on incoming materials and chemicals. TI and TI suppliers consider certain information to be proprietary, and thus CAS numbers and other limited information may not be available for release.

In no event shall TI's liability arising out of such information exceed the total purchase price of the TI part(s) at issue in this document sold by TI to Customer on an annual basis.

TAPE AND REEL INFORMATION

QUADRANT ASSIGNMENTS FOR PIN 1 ORIENTATION IN TAPE

*All dimensions are nominal

Device	Package Type	Package Drawing	Pins	SPQ	Reel Diameter (mm)	Reel Width W1 (mm)	A0 (mm)	B0 (mm)	K0 (mm)	P1 (mm)	W (mm)	Pin1 Quadrant
HD3SS3202IRSVR	UQFN	RSV	16	3000	178.0	13.5	2.1	2.9	0.75	4.0	12.0	Q1
HD3SS3202IRSVT	UQFN	RSV	16	250	178.0	13.5	2.1	2.9	0.75	4.0	12.0	Q1
HD3SS3202RSVR	UQFN	RSV	16	3000	178.0	13.5	2.1	2.9	0.75	4.0	12.0	Q1
HD3SS3202RSVT	UQFN	RSV	16	250	178.0	13.5	2.1	2.9	0.75	4.0	12.0	Q1

TAPE AND REEL BOX DIMENSIONS



*All dimensions are nominal

Device	Package Type	Package Drawing	Pins	SPQ	Length (mm)	Width (mm)	Height (mm)
HD3SS3202IRSVR	UQFN	RSV	16	3000	189.0	185.0	36.0
HD3SS3202IRSVT	UQFN	RSV	16	250	189.0	185.0	36.0
HD3SS3202RSVR	UQFN	RSV	16	3000	189.0	185.0	36.0
HD3SS3202RSVT	UQFN	RSV	16	250	189.0	185.0	36.0

GENERIC PACKAGE VIEW

RSV 16

UQFN - 0.55 mm max height

1.8 x 2.6, 0.4 mm pitch

ULTRA THIN QUAD FLATPACK - NO LEAD

This image is a representation of the package family, actual package may vary.
Refer to the product data sheet for package details.

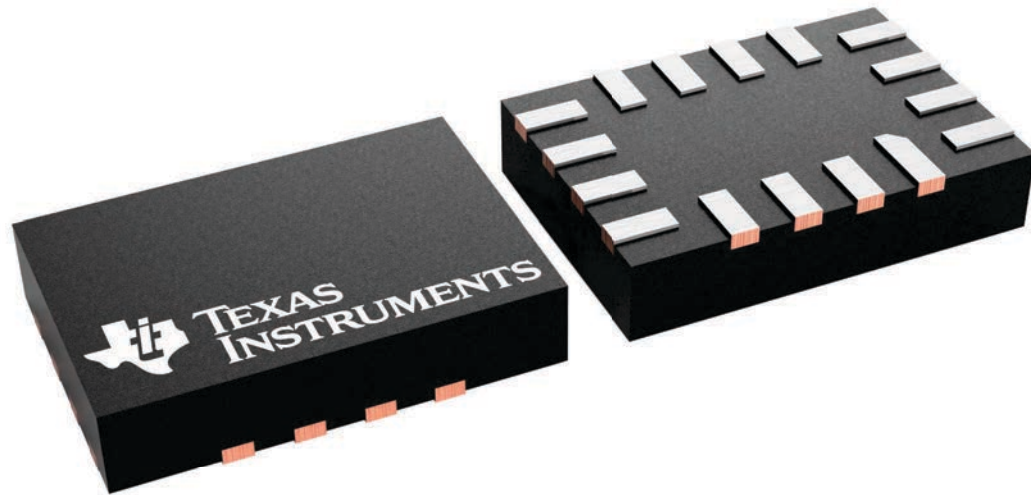

4231225/A

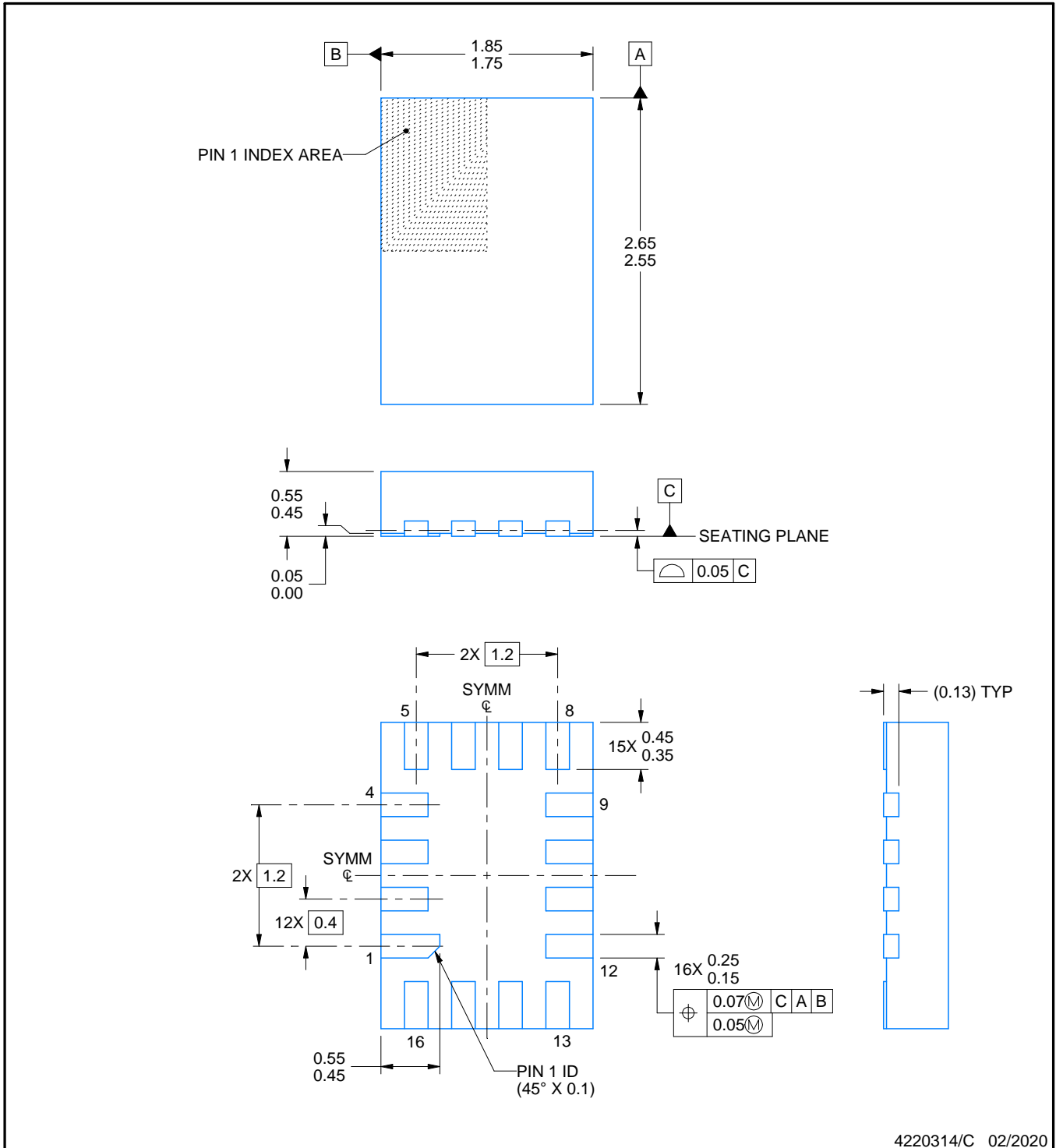
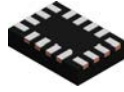

4220314/C 02/2020

NOTES:

1. All linear dimensions are in millimeters. Any dimensions in parenthesis are for reference only. Dimensioning and tolerancing per ASME Y14.5M.
2. This drawing is subject to change without notice.

EXAMPLE BOARD LAYOUT

RSV0016A

UQFN - 0.55 mm max height

ULTRA THIN QUAD FLATPACK - NO LEAD

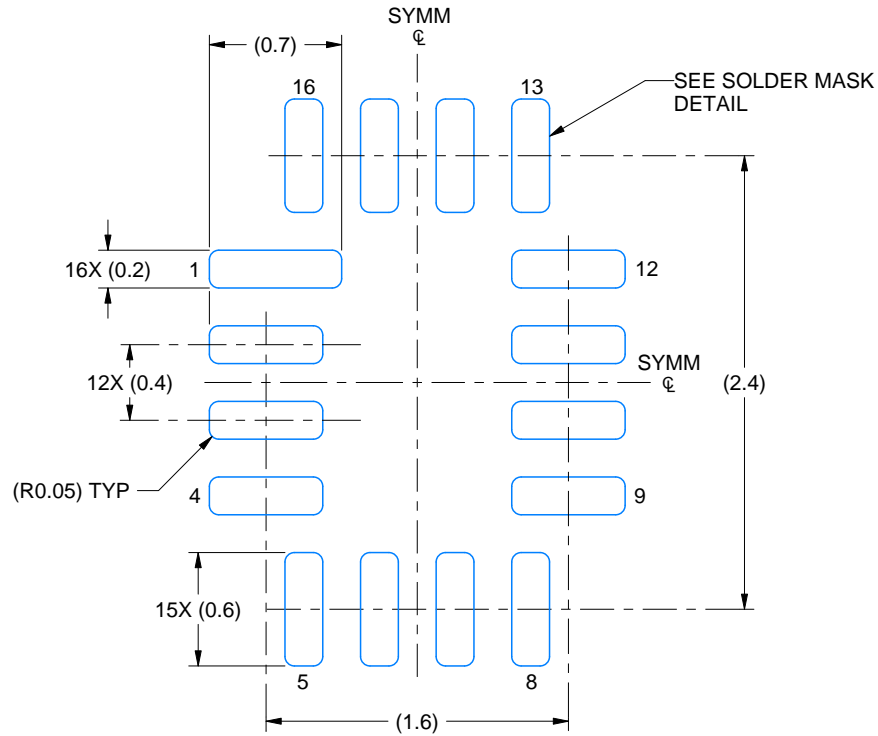

LAND PATTERN EXAMPLE
EXPOSED METAL SHOWN
SCALE: 25X

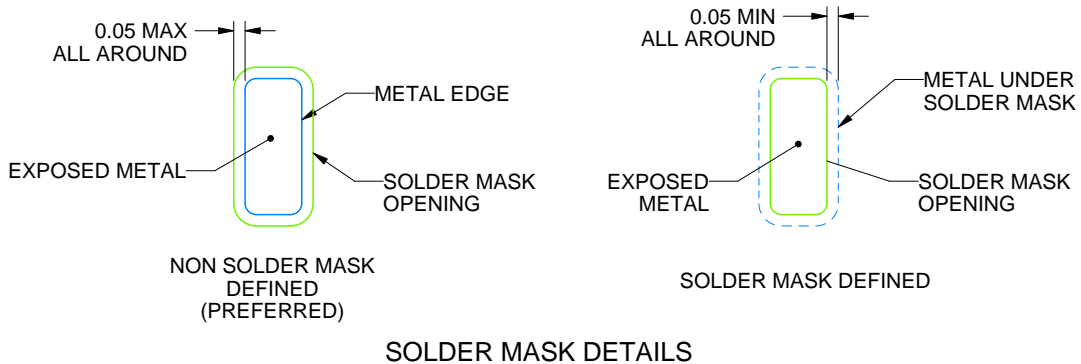

4220314/C 02/2020

NOTES: (continued)

3. For more information, see Texas Instruments literature number SLUA271 (www.ti.com/lit/slua271).

EXAMPLE STENCIL DESIGN

RSV0016A

UQFN - 0.55 mm max height

ULTRA THIN QUAD FLATPACK - NO LEAD

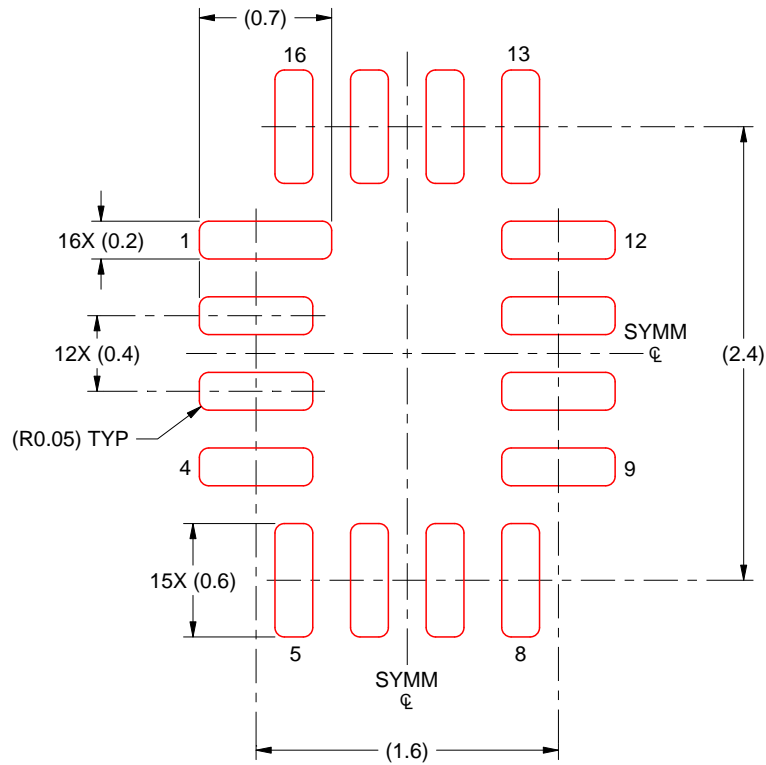

SOLDER PASTE EXAMPLE
BASED ON 0.125 MM THICK STENCIL
SCALE: 25X

4220314/C 02/2020

NOTES: (continued)

4. Laser cutting apertures with trapezoidal walls and rounded corners may offer better paste release. IPC-7525 may have alternate design recommendations.

重要なお知らせと免責事項

テキサス・インスツルメンツは、技術データと信頼性データ(データシートを含みます)、設計リソース(リファレンス デザインを含みます)、アプリケーションや設計に関する各種アドバイス、Web ツール、安全性情報、その他のリソースを、欠陥が存在する可能性のある「現状のまま」提供しており、商品性および特定目的に対する適合性の黙示保証、第三者の知的財産権の非侵害保証を含むいかなる保証も、明示的または黙示的にかかわらず拒否します。

これらのリソースは、テキサス・インスツルメンツ製品を使用する設計の経験を積んだ開発者への提供を意図したものです。(1) お客様のアプリケーションに適したテキサス・インスツルメンツ製品の選定、(2) お客様のアプリケーションの設計、検証、試験、(3) お客様のアプリケーションに該当する各種規格や、その他のあらゆる安全性、セキュリティ、規制、または他の要件への確実な適合に関する責任を、お客様のみが単独で負うものとし、ます。

上記の各種リソースは、予告なく変更される可能性があります。これらのリソースは、リソースで説明されているテキサス・インスツルメンツ製品を使用するアプリケーションの開発の目的でのみ、テキサス・インスツルメンツはその使用をお客様に許諾します。これらのリソースに関して、他の目的で複製することや掲載することは禁止されています。テキサス・インスツルメンツや第三者の知的財産権のライセンスが付与されている訳ではありません。お客様は、これらのリソースを自身で使用した結果発生するあらゆる申し立て、損害、費用、損失、責任について、テキサス・インスツルメンツおよびその代理人を完全に補償するものとし、テキサス・インスツルメンツは一切の責任を拒否します。

テキサス・インスツルメンツの製品は、[テキサス・インスツルメンツの販売条件](#)、または [ti.com](https://www.ti.com) やかかるテキサス・インスツルメンツ製品の関連資料などのいずれかを通じて提供する適用可能な条項の下で提供されています。テキサス・インスツルメンツがこれらのリソースを提供することは、適用されるテキサス・インスツルメンツの保証または他の保証の放棄の拡大や変更を意味するものではありません。

お客様がいかなる追加条項または代替条項を提案した場合でも、テキサス・インスツルメンツはそれらに異議を唱え、拒否します。

郵送先住所：Texas Instruments, Post Office Box 655303, Dallas, Texas 75265
Copyright © 2025, Texas Instruments Incorporated