

INA220 ハイサイドまたはローサイド、双方向電流および電力モニタ 2線式インターフェイス搭載

1 特長

- ハイサイドまたはローサイドのセンシング
- 0V～26Vのバス電圧を検出
- 電流、電圧、電力を報告
- 16のアドレスをプログラム可能
- 高精度: 温度範囲全体にわたって0.5% (最大値、INA220B)
- 較正をユーザーがプログラム可能
- 高速(2.56MHz) I²CまたはSMBUS互換インターフェイス
- VSSOP-10パッケージ

2 アプリケーション

- サーバー
- 通信機器
- ノートブック・コンピュータ
- パワー・マネージメント
- バッテリー充電器
- 自動車
- 電源
- 試験用機器

3 概要

INA220は、I²C またはSMBUS互換インターフェイスを搭載した電流シャントおよび電力モニタです。INA220は、シャントの電圧降下と電源電圧の両方を監視します。プログラム可能な較正值と、内部的なマルチプライヤとの組み合わせにより、値をアンペア単位で直接読み出すことが可能です。追加の乗算レジスタにより、電力がワット単位で計算されます。I²CまたはSMBUS互換のインターフェイスは、16のアドレスをプログラム可能です。INA220には独立のシャント入力があり、ローサイド・センシングのシステムで使用可能です。

INA220にはAとBの2つのグレードが存在し、Bグレードのほうが高い正確度と精度の仕様を満たしています。

INA220は0～26Vの範囲で変動するバス上でシャントの両端の電圧を検出できるため、ローサイド・センシングやCPU電源に便利です。このデバイスは3～5.5Vの単一電源で動作し、消費電流は最大1mAです。INA220の動作温度範囲は、-40℃～125℃です。

製品情報⁽¹⁾

型番	パッケージ	本体サイズ(公称)
INA220	VSSOP (10)	3.00mm×3.00mm

(1) 提供されているすべてのパッケージについては、データシートの末尾にある注文情報を参照してください。

一般的な負荷、ローサイドまたはハイサイド・センシング

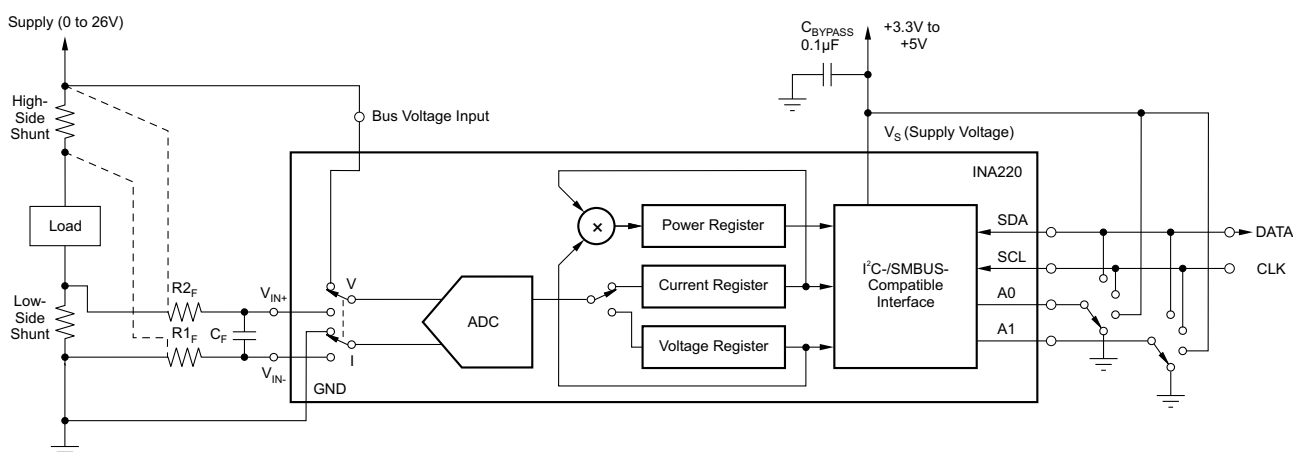

目次

1	特長	1	8.4	Device Functional Modes	11
2	アプリケーション	1	8.5	Programming	12
3	概要	1	8.6	Register Maps	18
4	改訂履歴	2	9	Application and Implementation	25
5	Related Products	4	9.1	Application Information	25
6	Pin Configuration and Functions	4	9.2	Typical Application	25
7	Specifications	5	10	Power Supply Recommendations	29
7.1	Absolute Maximum Ratings	5	11	Layout	29
7.2	ESD Ratings	5	11.1	Layout Guidelines	29
7.3	Recommended Operating Conditions	5	11.2	Layout Example	29
7.4	Thermal Information	5	12	デバイスおよびドキュメントのサポート	30
7.5	Electrical Characteristics	6	12.1	関連資料	30
7.6	Bus Timing Diagram Definitions	7	12.2	コミュニティ・リソース	30
7.7	Typical Characteristics	8	12.3	商標	30
8	Detailed Description	10	12.4	静電気放電に関する注意事項	30
8.1	Overview	10	12.5	用語集	30
8.2	Functional Block Diagram	10	13	メカニカル、パッケージ、および注文情報	30
8.3	Feature Description	10			

4 改訂履歴

資料番号末尾の英字は改訂を表しています。その改訂履歴は英語版に準じています。

Revision D (September 2010) から Revision E に変更

Page

• 「ESD定格」表、「機能説明」セクション、「デバイスの機能モード」セクション、「アプリケーションと実装」セクション、「電源に関する推奨事項」セクション、「レイアウト」セクション、「デバイスおよびドキュメントのサポート」セクション、「メカニカル、パッケージ、および注文情報」セクション 追加	1
• 表紙の図 変更	1
• Changed pin names in the pin description.	4
• Changed the temperature values in the <i>Absolute Maximum Ratings</i> table	5
• Changed Ambient temperature from –25 to –40 in the MIN column.	5
• Deleted <i>Temperature Range</i> parameters from <i>Electrical Characteristics</i> .	7
• Changed I2C timing spec change based on characterization data.	7

Revision C (September, 2009) から Revision D に変更

Page

• 「特長」の箇条書きで「高精度」を1%からBグレード・デバイスの0.5%に変更	1
• 「概要」に、デバイスのAおよびBグレードのバージョンに関する段落を追加	1
• Added new row to <i>Packaging Information</i> table to show new B-grade device	4
• Added B-grade columns in <i>Electrical Characteristics</i> for MIN, TYP and MAX values	6
• Changed <i>Current Sense Gain Error over temperature</i> specification from 10 ppm/°C to 1m%/°C	6
• Added <i>Configure/Measure/Calculate Example</i>	25

Revision B (June, 2009) から Revision C に変更**Page**

• Changed specified temperature range from -25°C to -40°C	6
• Changed Offset Voltage (RTI) vs Temperature minimum specification from $0.1\ \mu\text{V}/^{\circ}\text{C}$ to $0.16\ \mu\text{V}/^{\circ}\text{C}$	6
• Changed <i>Typical Characteristics</i> : Figure 3 , Figure 4 , Figure 5 , Figure 6	8
• Changed <i>Typical Characteristics</i> : Figure 9 , Figure 10	8

5 Related Products

DEVICE	DESCRIPTION
INA209	Current/power monitor with watchdog, peak-hold, and fast comparator functions
INA210 , INA211 , INA212 , INA213 , INA214	Zero-drift, low-cost, analog current shunt monitor series in small package
INA219	Zero-drift, bidirectional current power monitor with two-wire interface

6 Pin Configuration and Functions

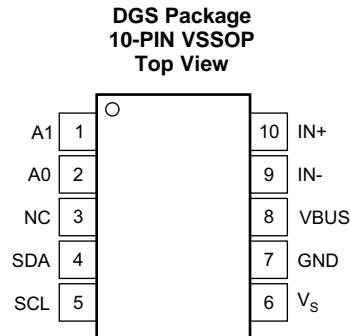

Pin Functions

PIN		I/O	DESCRIPTION
NAME	NO.		
A1	1	Digital Input	Address pin. Connect to GND, SCL, SDA, or V_S . Table 1 shows pin settings and corresponding addresses.
A0	2	Digital Input	Address pin. Connect to GND, SCL, SDA, or V_S . Table 1 shows pin settings and corresponding addresses.
NC	3	—	No internal connection
SDA	4	Digital I/O	Serial bus data line
SCL	5	Digital Input	Serial bus clock line
V_S	6	Analog	Power supply, 3 V to 5.5 V
GND	7	Analog	Ground
VBUS	8	Analog Input	Bus voltage input
IN-	9	Analog Input	Negative differential shunt voltage. Connect to negative side of shunt resistor. Bus voltage is measured from this pin to ground.
IN+	10	Analog Input	Positive differential shunt voltage. Connect to positive side of shunt resistor.

7 Specifications

7.1 Absolute Maximum Ratings

over operating free-air temperature range (unless otherwise noted).⁽¹⁾

		MIN	MAX	UNIT
V _S	Supply voltage		6	V
Analog inputs IN+, IN–	Differential (V _{IN+}) – (V _{IN–}) ⁽²⁾	–26	26	V
	Common-mode (V _{IN+} + V _{IN–}) / 2	–0.3	26	V
V _{VBUS}	Voltage at VBUS pin	–0.3	26	V
V _{SDA}	Voltage at SDA pin	GND – 0.3	6	V
V _{SCL}	Voltage at SCL pin	GND – 0.3	V _S + 0.3	V
Input current into any pin			5	mA
Open-drain digital output current			10	mA
Operating temperature		–40	125	°C
T _J	Junction temperature		150	°C
T _{stg}	Storage temperature	–65	150	°C

- (1) Stresses beyond those listed under *Absolute Maximum Ratings* may cause permanent damage to the device. These are stress ratings only, which do not imply functional operation of the device at these or any other conditions beyond those indicated under *Recommended Operating Conditions*. Exposure to absolute-maximum-rated conditions for extended periods may affect device reliability.
- (2) IN+ and IN– may have a differential voltage of –26 to 26 V; however, the voltage at these pins must not exceed the range of –0.3 to 26 V.

7.2 ESD Ratings

		VALUE	UNIT
V _(ESD)	Electrostatic discharge	Human body model (HBM), per ANSI/ESDA/JEDEC JS-001, all pins ⁽¹⁾	±4000
		Charged device model (CDM), per JEDEC specification JESD22-C101, all pins ⁽²⁾	±1000
		Machine model (MM)	±150

- (1) JEDEC document JEP155 states that 500-V HBM allows safe manufacturing with a standard ESD control process.
- (2) JEDEC document JEP157 states that 250-V CDM allows safe manufacturing with a standard ESD control process.

7.3 Recommended Operating Conditions

over operating free-air temperature range (unless otherwise noted)

		MIN	NOM	MAX	UNIT
V _{CM}	(V _{IN+} + V _{IN–}) / 2		12		V
V _S	Supply voltage		3.3		V
T _A	Ambient temperature	–40		85	°C

7.4 Thermal Information

THERMAL METRIC ⁽¹⁾		INA220	UNIT
		DGS (VSSOP)	
		10 PINS	
R _{θJA}	Junction-to-ambient thermal resistance	165.4	°C/W
R _{θJC(top)}	Junction-to-case (top) thermal resistance	53.2	°C/W
R _{θJB}	Junction-to-board thermal resistance	86.6	°C/W
ψ _{JT}	Junction-to-top characterization parameter	6.4	°C/W
ψ _{JB}	Junction-to-board characterization parameter	85.0	°C/W

- (1) For more information about traditional and new thermal metrics, see the *Semiconductor and IC Package Thermal Metrics* application report, [SPRA953](#).

7.5 Electrical Characteristics

at $T_A = 25^\circ\text{C}$, $V_S = 3.3\text{ V}$, $V_{IN+} = 12\text{ V}$, $V_{SHUNT} = (V_{IN+} - V_{IN-}) = 32\text{ mV}$, $V_{VBUS} = 12\text{ V}$, $\text{PGA} = /1$, and $\text{BRNG}^{(1)} = 1$, unless otherwise noted.

		TEST CONDITIONS	INA220A			INA220B			UNIT
			MIN	TYP	MAX	MIN	TYP	MAX	
INPUT									
Full-scale current sense (input) voltage range	V_{SHUNT}	PGA = /1	0		±40	0		±40	mV
		PGA = /2	0		±80	0		±80	mV
		PGA = /4	0		±160	0		±160	mV
		PGA = /8	0		±320	0		±320	mV
Bus voltage (input voltage) ⁽²⁾		BRNG = 1	0		32	0		32	V
		BRNG = 0	0		16	0		16	V
Common-mode rejection		$V_{IN+} = 0\text{ to }26\text{ V}$	100	120		100	120		dB
Offset Voltage, RTI ⁽³⁾	V_{OS}	PGA = /1		±10	±100		±10	±50 ⁽⁴⁾	µV
		PGA = /2		±20	±125		±20	±75 ⁽⁴⁾	µV
		PGA = /4		±30	±150		±30	±75 ⁽⁴⁾	µV
		PGA = /8		±40	±200		±40	±100 ⁽⁴⁾	µV
		versus power supply	PSRR	$V_S = 3\text{ to }5.5\text{ V}$		10		10	
Current sense gain error				±40			±40		m%
		$T_A = -40^\circ\text{C to }85^\circ\text{C}$		1			1		m%/°C
IN+ pin input impedance		Active mode		20			20		µA
IN– pin input impedance		Active mode		20			20		µA
VBUS pin input impedance ⁽⁵⁾		Active mode		320			320		kΩ
IN+ pin input leakage ⁽⁶⁾		Power-down mode		0.1	±0.5		0.1	±0.5	µA
IN– pin input leakage ⁽⁶⁾		Power-down mode		0.1	±0.5		0.1	±0.5	µA
DC ACCURACY									
ADC basic resolution				12			12		bits
Shunt voltage		1-LSB step size		10			10		µV
Bus voltage		1-LSB step size		4			4		mV
Current measurement error				±0.2%	±0.5%		±0.2%	±0.3% ⁽⁴⁾	
		over Temperature $T_A = -40^\circ\text{C to }85^\circ\text{C}$				±1%		±0.5% ⁽⁴⁾	
Bus voltage measurement error		$V_{BUS} = 12\text{ V}$		±0.2%	±0.5%		±0.2%	±0.5%	
		over Temperature $T_A = -40^\circ\text{C to }85^\circ\text{C}$				±1%		±1%	
Differential nonlinearity				±0.1			±0.1		LSB
ADC TIMING									
ADC conversion time		12-bit		532	586		532	586	µs
		11-bit		276	304		276	304	µs
		10-bit		148	163		148	163	µs
		9-bit		84	93		84	93	µs
Minimum convert input low time			4			4		µs	
SMBus									
SMBus timeout ⁽⁷⁾				28	35		28	35	ms

- (1) BRNG is bit 13 of the Configuration Register 00h (see [Figure 19](#)).
- (2) This parameter only expresses the full-scale range of the ADC scaling. In no event should more than 26 V be applied to this device.
- (3) Referred-to-input (RTI)
- (4) Indicates improved specifications of the INA220B.
- (5) The input impedance of this pin may vary approximately ±15%.
- (6) Input leakage is positive (current flowing into the pin) for the conditions shown at the top of the table. Negative leakage currents can occur under different input conditions.
- (7) SMBus timeout in the INA220 resets the interface any time SCL or SDA is low for more than 28 ms.

Electrical Characteristics (continued)

at $T_A = 25^\circ\text{C}$, $V_S = 3.3\text{ V}$, $V_{IN+} = 12\text{ V}$, $V_{SHUNT} = (V_{IN+} - V_{IN-}) = 32\text{ mV}$, $V_{VBUS} = 12\text{ V}$, $\text{PGA} = /1$, and $\text{BRNG}^{(1)} = 1$, unless otherwise noted.

	TEST CONDITIONS	INA220A			INA220B			UNIT
		MIN	TYP	MAX	MIN	TYP	MAX	
DIGITAL INPUTS (SDA as Input, SCL, A0, A1)								
Input capacitance		3			3			pF
Leakage input current	$0 \leq V_{IN} \leq V_S$	0.1			0.1			μA
V_{IH} input logic level		0.7 (V_S)			0.7 (V_S)			V
V_{IL} input logic level		-0.3			-0.3			V
Hysteresis		500			500			mV
OPEN-DRAIN DIGITAL OUTPUTS (SDA)								
Logic 0 output level	$I_{\text{SINK}} = 3\text{ mA}$	0.15			0.15			V
High-level output leakage current	$V_{\text{OUT}} = V_S$	0.1			0.1			μA
POWER SUPPLY								
Operating supply range		3			3			V
Quiescent current		0.7			0.7			mA
Quiescent current, power-down mode		6			6			μA
Power-on reset threshold		2			2			V

7.6 Bus Timing Diagram Definitions⁽¹⁾

		FAST MODE			HIGH-SPEED MODE			UNIT
		MIN	TYP	MAX	MIN	TYP	MAX	
f_{SCL}	SCL operating frequency	0.001			0.001			MHz
t_{BUF}	Bus free time between STOP and START condition	1300			160			ns
t_{HDSTA}	Hold time after repeated START condition. After this period, the first clock is generated.	600			160			ns
t_{SUSTA}	Repeated START condition setup time	600			160			ns
t_{SUSTO}	STOP condition setup time	600			160			ns
t_{HDDAT}	Data hold time	0			90			ns
t_{SUDAT}	Data setup time	100			10			ns
t_{LOW}	SCL clock LOW period	1300			250			ns
t_{HIGH}	SCL clock HIGH period	600			60			ns
t_{FDA}	Data fall time	300			150			ns
t_{FCL}	Clock fall time	300			40			ns
t_{RCL}	Clock rise time	300			40			ns
t_{RCL}	Clock rise time for SCLK $\leq 100\text{ kHz}$	1000						ns

(1) Values based on a statistical analysis of a one-time sample of devices. Minimum and maximum values are not ensured and not production tested. Condition: A0=A1=0.

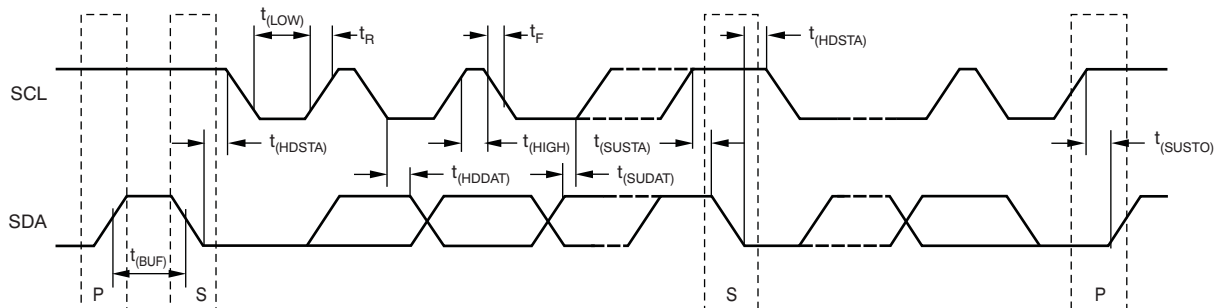

Figure 1. Bus Timing Diagram

7.7 Typical Characteristics

at $T_A = 25^\circ\text{C}$, $V_S = 3.3\text{ V}$, $V_{IN+} = 12\text{ V}$, $V_{SHUNT} = (V_{IN+} - V_{IN-}) = 32\text{ mV}$, $\text{PGA} = /1$, and $\text{BRNG} = 1$, unless otherwise noted.

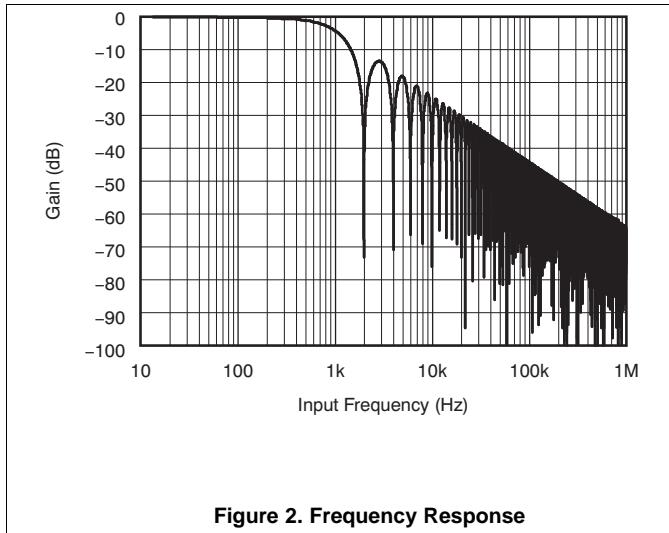

Figure 2. Frequency Response

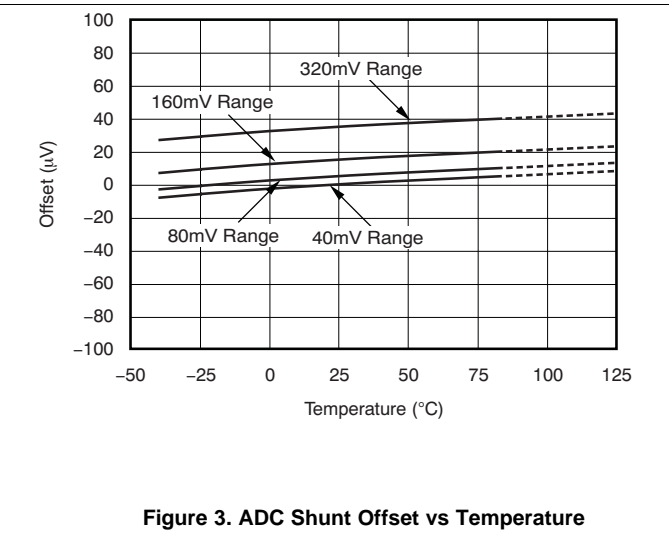

Figure 3. ADC Shunt Offset vs Temperature

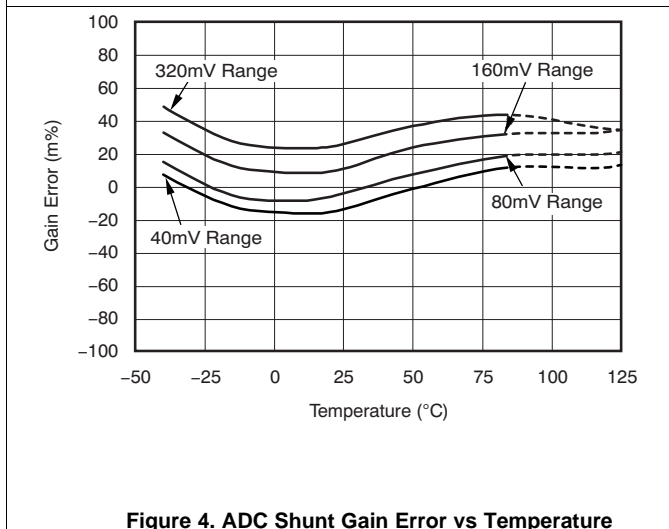

Figure 4. ADC Shunt Gain Error vs Temperature

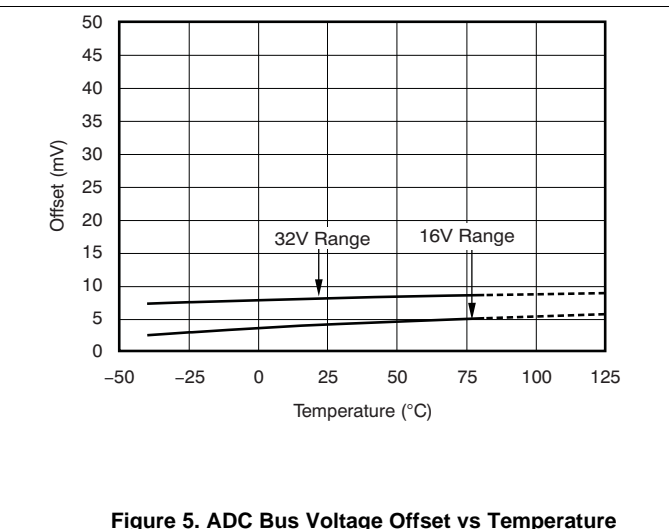

Figure 5. ADC Bus Voltage Offset vs Temperature

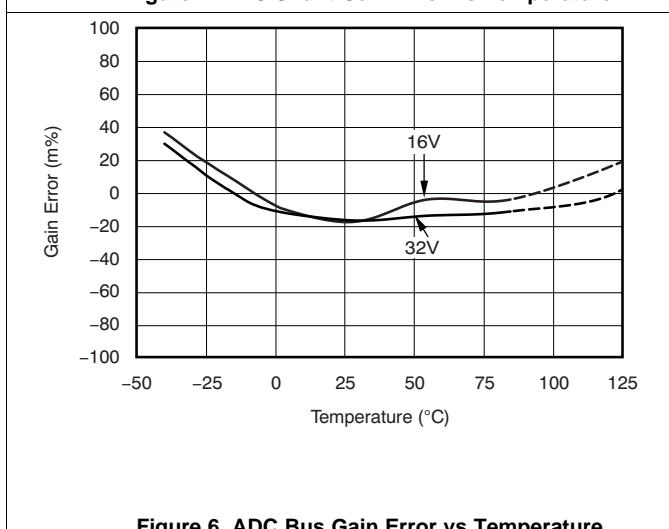

Figure 6. ADC Bus Gain Error vs Temperature

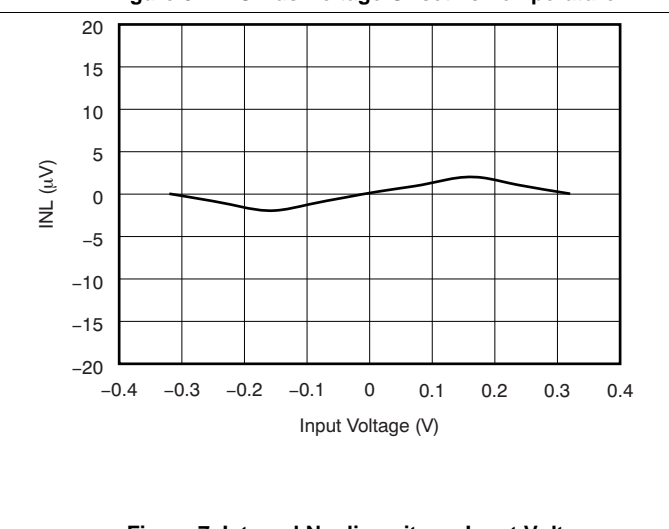

Figure 7. Integral Nonlinearity vs Input Voltage

Typical Characteristics (continued)

at $T_A = 25^\circ\text{C}$, $V_S = 3.3\text{ V}$, $V_{IN+} = 12\text{ V}$, $V_{SHUNT} = (V_{IN+} - V_{IN-}) = 32\text{ mV}$, $\text{PGA} = /1$, and $\text{BRNG} = 1$, unless otherwise noted.

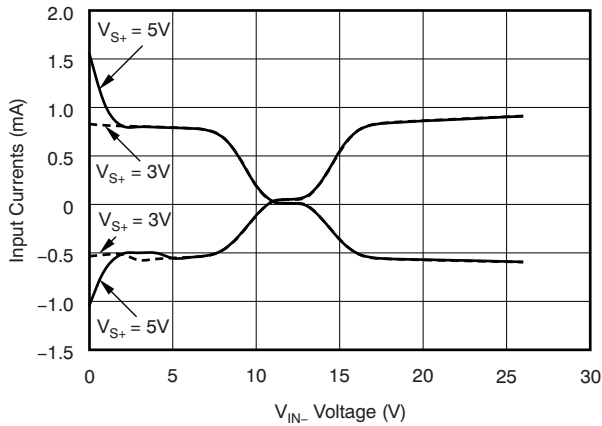

Figure 8. Input Currents With Large Differential Voltages (V_{IN+} at 12 V, Sweep Of V_{IN-})

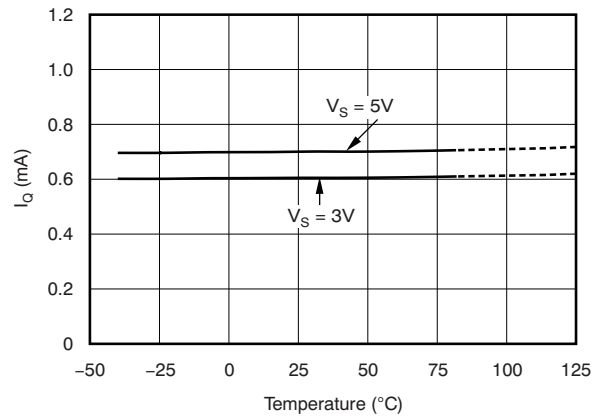

Figure 9. Active I_Q vs Temperature

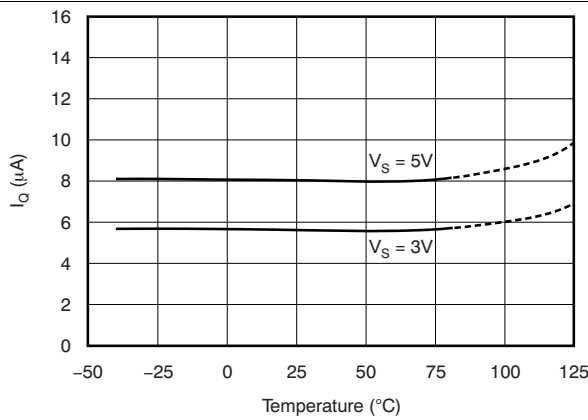

Figure 10. Shutdown I_Q vs Temperature

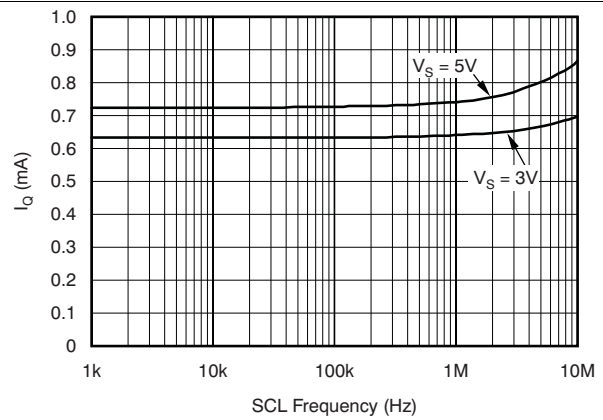

Figure 11. Active I_Q vs Two-Wire Clock Frequency

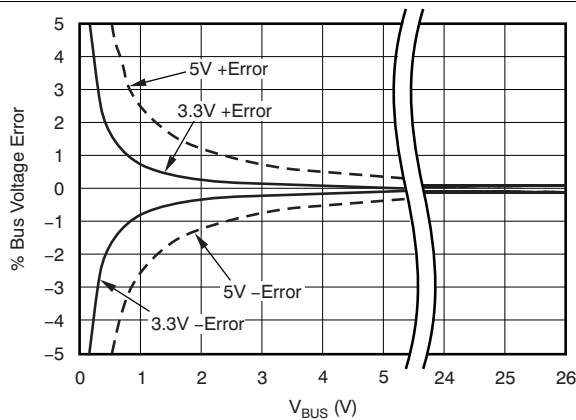

Figure 12. Total Percent Bus Voltage Error vs Supply Voltage

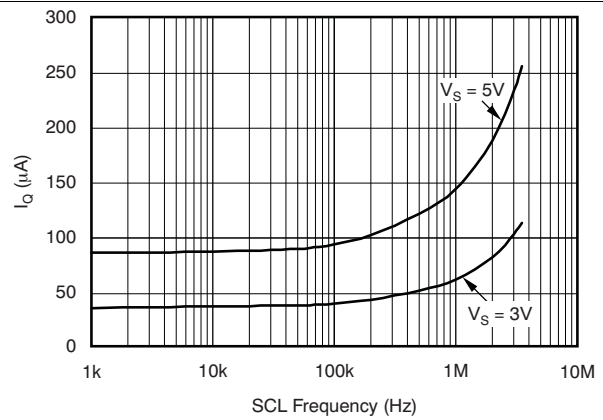

Figure 13. Shutdown I_Q vs Two-Wire Clock Frequency

8 Detailed Description

8.1 Overview

The INA220 is a digital current sense amplifier with an I²C- and SMBus-compatible interface. It provides digital current, voltage, and power readings necessary for accurate decision-making in precisely-controlled systems. Programmable registers allow flexible configuration for measurement resolution as well as continuous-versus-triggered operation. Detailed register information appears at the end of this data sheet, beginning with [Table 2](#). See [Functional Block Diagram](#) for a block diagram of the INA220 device.

8.2 Functional Block Diagram

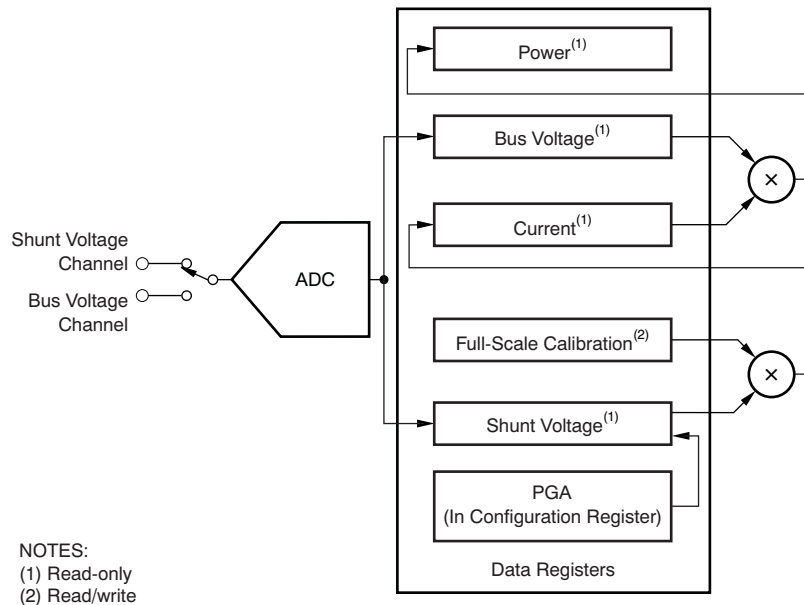

8.3 Feature Description

8.3.1 Basic ADC Functions

The two analog inputs to the INA220, IN+ and IN–, connect to a shunt resistor in the bus of interest. Bus voltage is measured at VBUS pin. The INA220 is typically powered by a separate supply from 3 to 5.5 V. The bus being sensed can vary from 0 to 26 V. It requires no special considerations for power-supply sequencing (for example, a bus voltage can be present with the supply voltage off, and vice-versa). The INA220 senses the small drop across the shunt for shunt voltage, and senses the voltage with respect to ground from VBUS pin for the bus voltage.

When the INA220 is in the normal operating mode (that is, MODE bits of the Configuration register are set to 111), it continuously converts the shunt voltage up to the number set in the shunt voltage averaging function (Configuration register, SADC bits). The device then converts the bus voltage up to the number set in the bus voltage averaging (Configuration register, BADC bits). The Mode control in the Configuration register also permits selecting modes to convert only voltage or current, either continuously or in response to an event (triggered).

All current and power calculations are performed in the background and do not contribute to conversion time; conversion times shown in [Electrical Characteristics](#) can be used to determine the actual conversion time.

Power-down mode reduces the quiescent current and turns off current into the INA220 inputs, avoiding any supply drain. Full recovery from power-down requires 40 μs. ADC off mode (set by the Configuration register, MODE bits) stops all conversions.

In triggered mode, writing any of the triggered convert modes into the Configuration register (even if the desired mode is already programmed into the register) triggers a single-shot conversion.

Feature Description (continued)

Although the INA220 can be read at any time, and the data from the last conversion remain available, the Conversion Ready bit (Status register, CNVR bit) is provided to help coordinate one-shot or triggered conversions. The Conversion Ready bit is set after all conversions, averaging, and multiplication operations are complete.

The Conversion Ready bit clears under any of these conditions:

- Writing to the Configuration register, except when configuring the MODE bits for power down or ADC off (disable) modes
- Reading the Status register
- Triggering a single-shot conversion with the convert pin

8.3.1.1 Power Measurement

Current and bus voltage are converted at different points in time, depending on the resolution and averaging mode settings. For instance, when configured for 12-bit and 128-sample averaging, up to 68 ms in time between sampling these two values is possible. Again, these calculations are performed in the background and do not add to the overall conversion time.

8.3.1.2 PGA Function

If larger full-scale shunt voltages are desired, the INA220 provides a PGA function that increases the full-scale range up to 2, 4, or 8 times (320 mV). Additionally, the bus voltage measurement has two full-scale ranges: 16 or 32 V.

8.3.1.3 Compatibility With TI Hot Swap Controllers

The INA220 is designed for compatibility with hot swap controllers such as the TI [TPS2490](#). The TPS2490 uses a high-side shunt with a limit at 50 mV; the INA220 full-scale range of 40 mV enables the use of the same shunt for current sensing below this limit. When sensing is required at (or through) the 50-mV sense point of the TPS2490, the PGA of the INA220 can be set to /2 to provide an 80-mV full-scale range.

8.4 Device Functional Modes

8.4.1 Filtering and Input Considerations

Measuring current is often noisy, and such noise can be difficult to define. The INA220 offers several options for filtering by choosing resolution and averaging in the Configuration register. These filtering options can be set independently for either voltage or current measurement.

The internal ADC is based on a delta-sigma ($\Delta\Sigma$) front-end with a 500-kHz ($\pm 30\%$) typical sampling rate. This architecture has good inherent noise rejection; however, transients that occur at or very close to the sampling rate harmonics can cause problems. Because these signals are at 1 MHz and higher, they can be dealt with by incorporating filtering at the input of the INA220. The high frequency enables the use of low-value series resistors on the filter for negligible effects on measurement accuracy. In general, filtering the INA220 input is only necessary if there are transients at exact harmonics of the 500-kHz ($\pm 30\%$) sampling rate (>1 MHz). Filter using the lowest possible series resistance and ceramic capacitor. TI recommends values of 0.1 to 1 μF . [Figure 14](#) shows the INA220 with an additional filter added at the input.

Overload conditions are another consideration for the INA220 inputs. The INA220 inputs are specified to tolerate 26 V across the inputs. A large differential scenario might be a short to ground on the load side of the shunt. This type of event can result in full power-supply voltage across the shunt (as long as the power supply or energy storage capacitors support it). It must be remembered that removing a short to ground can result in inductive kickbacks that could exceed the 26-V differential and common-mode rating of the INA220. Inductive kickback voltages are best dealt with by Zener-type transient-absorbing devices combined with sufficient energy storage capacitance.

Device Functional Modes (continued)

In applications that do not have large energy storage electrolytics on one or both sides of the shunt, an input overstress condition may result from an excessive dV/dt of the voltage applied to the input. A hard physical short is the most likely cause of this event, particularly in applications with no large electrolytics present. This problem occurs because an excessive dV/dt can activate the ESD protection in the INA220 in systems where large currents are available. Testing has demonstrated that the addition of 10- Ω resistors in series with each input of the INA220 sufficiently protects the inputs against dV/dt failure up to the 26-V rating of the INA220. These resistors have no significant effect on accuracy.

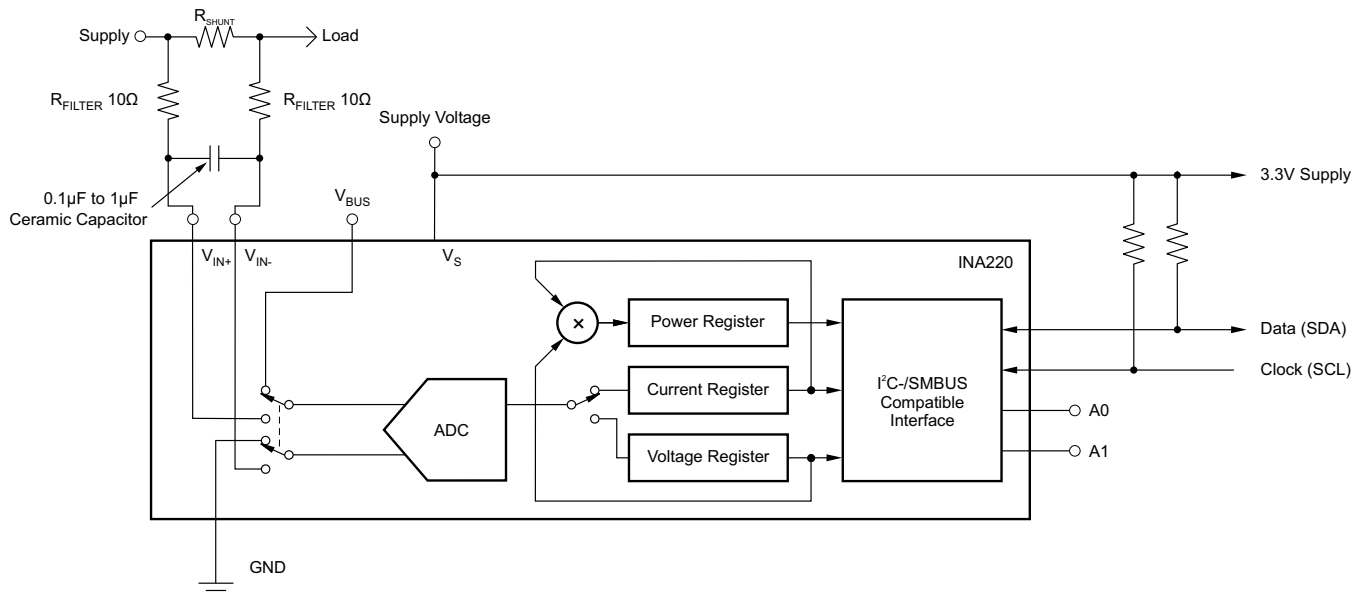

Figure 14. INA220 With Input Filtering

8.5 Programming

8.5.1 Programming the INA220 Calibration Register

[Register Details](#) shows the default power-up states of the registers. These registers are volatile, and if programmed to anything other than default values, they must be reprogrammed at every device power-up. The Calibration Register is calculated based on [Equation 1](#). This equation includes the term `Current_LSB`, which is the programmed value for the LSB for the Current Register (04h). The `Current_LSB` value is used to convert the value in the Current Register (04h) to the actual current in amperes. The highest resolution for the Current Register (04h) can be obtained by using the smallest allowable `Current_LSB` based on the maximum expected current as shown in [Equation 2](#). While this value yields the highest resolution, it is common to select a value for the `Current_LSB` to the nearest round number above this value to simplify the conversion of the Current Register (04h) and Power Register (03h) to amperes and watts respectively. The R_{SHUNT} term is the value of the external shunt used to develop the differential voltage across the input pins. The Power Register (03h) is internally set to be 20 times the programmed `Current_LSB` (see [Equation 3](#)).

$$\text{Cal} = \text{trunc} \left[\frac{0.04096}{\text{Current_LSB} \times R_{SHUNT}} \right]$$

where

- 0.04096 is an internal fixed value used to ensure scaling is maintained properly
- `Current_LSB` is the programmed value for the LSB for the Current Register (04h) (1)

$$\text{Current_LSB} = \frac{\text{Maximum Expected Current}}{2^{15}} \quad (2)$$

$$\text{Power_LSB} = 20 \text{ Current_LSB} \quad (3)$$

Programming (continued)

Shunt voltage is calculated by multiplying the Shunt Voltage Register contents with the Shunt Voltage LSB of 10 μ V. The Bus Voltage register bits are not right-aligned. To compute the value of the Bus Voltage, Bus Voltage Register contents must be shifted right by three bits. This shift puts the BD0 bit in the LSB position so that the contents can be multiplied by the Bus Voltage LSB of 4-mV to compute the bus voltage measured by the device. After programming the Calibration Register, the value expected in the Current Register (04h) can be calculated by multiplying the Shunt Voltage register contents by the Calibration Register and then dividing by 4096 as shown in [Equation 4](#). To obtain a value in amperes, the Current register value is multiplied by the programmed Current_LSB.

$$\text{Current Register} = \frac{\text{Shunt Voltage Register} \times \text{Calibration Register}}{4096} \quad (4)$$

The value expected in the Power register (03h) can be calculated by multiplying the Current register value by the Bus Voltage register value and then dividing by 5000 as shown in [Equation 5](#). Power Register content is multiplied by Power LSB which is 20 times the Current_LSB for a power value in watts.

$$\text{Power Register} = \frac{\text{Current Register} \times \text{Bus Voltage Register}}{5000} \quad (5)$$

8.5.2 Programming the INA220 Power Measurement Engine

8.5.2.1 Calibration Register and Scaling

The Calibration register makes it possible to set the scaling of the Current and Power registers to whatever values are most useful for a given application. One strategy may be to set the Calibration register such that the largest possible number is generated in the Current register or Power register at the expected full-scale point; this approach yields the highest resolution. The Calibration register can also be selected to provide values in the Current and Power registers that either provide direct decimal equivalents of the values being measured, or yield a round LSB number. After these choices have been made, the Calibration register also offers possibilities for end-user system-level calibration, where the value is adjusted slightly to cancel total system error. After determining the exact current by using an external ammeter, the value of the Calibration Register can then be adjusted based on the measured current result of the INA220 to cancel the total system error as shown in [Equation 6](#).

$$\text{Corrected_Full_Scale_Cal} = \text{trunc} \left(\frac{\text{Cal} \times \text{MeasShuntCurrent}}{\text{INA220_Current}} \right) \quad (6)$$

8.5.3 Simple Current Shunt Monitor Usage (No Programming Necessary)

The INA220 can be used without any programming if it is only necessary to read a shunt voltage drop and bus voltage with the default 12-bit resolution, 320-mV shunt full-scale range (PGA = /8), 32-V bus full-scale range, and continuous conversion of shunt and bus voltage.

Without programming, current is measured by reading the shunt voltage. The Current register and Power register are only available if the Calibration register contains a programmed value.

8.5.4 Bus Overview

The INA220 offers compatibility with both I²C and SMBus interfaces. The I²C and SMBus protocols are essentially compatible with one another.

The I²C interface is used throughout this data sheet as the primary example, with SMBus protocol specified only when a difference between the two systems is being addressed. Two lines, SCL and SDA, connect the INA220 to the bus. Both SCL and SDA are open-drain connections.

The device that initiates the transfer is called a *master*, and the devices controlled by the master are *slaves*. The bus must be controlled by a master device that generates the serial clock (SCL), controls the bus access, and generates START and STOP conditions.

Programming (continued)

To address a specific device, the master initiates a START condition by pulling the data signal line (SDA) from a high to a low logic level while SCL is high. All slaves on the bus shift in the slave address byte on the rising edge of SCL, with the last bit indicating whether a read or write operation is intended. During the ninth clock pulse, the slave being addressed responds to the master by generating an Acknowledge and pulling SDA low.

Data transfer is then initiated and eight bits of data are sent, followed by an *Acknowledge* bit. During data transfer, SDA must remain stable while SCL is high. Any change in SDA while SCL is high is interpreted as a START or STOP condition.

After all data have been transferred, the master generates a STOP condition, indicated by pulling SDA from low to high while SCL is high. The INA220 includes a 28-ms timeout on its interface to prevent locking up an SMBus.

8.5.4.1 Serial Bus Address

To communicate with the INA220, the master must first address slave devices through a slave address byte. The slave address byte consists of seven address bits, and a direction bit indicating the intent of executing a read or write operation.

The INA220 has two address pins, A0 and A1. [Table 1](#) describes the pin logic levels for each of the 16 possible addresses. The state of pins A0 and A1 is sampled on every bus communication and should be set before any activity on the interface occurs. The address pins are read at the start of each communication event.

Table 1. INA220 Address Pins and Slave Addresses

A1	A0	SLAVE ADDRESS
GND	GND	1000000
GND	V _S	1000001
GND	SDA	1000010
GND	SCL	1000011
V _S	GND	1000100
V _S	V _S	1000101
V _S	SDA	1000110
V _S	SCL	1000111
SDA	GND	1001000
SDA	V _S	1001001
SDA	SDA	1001010
SDA	SCL	1001011
SCL	GND	1001100
SCL	V _S	1001101
SCL	SDA	1001110
SCL	SCL	1001111

8.5.4.2 Serial Interface

The INA220 operates only as a slave device on the I²C bus and SMBus. Connections to the bus are made by the open-drain I/O lines SDA and SCL. The SDA and SCL pins feature integrated spike suppression filters and Schmitt triggers to minimize the effects of input spikes and bus noise. The INA220 supports the transmission protocol for fast (1-kHz to 400-kHz) and high-speed (1-kHz to 2.56-MHz) modes. All data bytes are transmitted most significant byte first.

8.5.5 Writing to and Reading from the INA220

Accessing a particular register on the INA220 is accomplished by writing the appropriate value to the register pointer. Refer to [Table 2](#) for a complete list of registers and corresponding addresses. The value for the register pointer, as shown in [Figure 18](#), is the first byte transferred after the slave address byte with the R/W bit LOW. Every write operation to the INA220 requires a value for the register pointer.

Writing to a register begins with the first byte transmitted by the master. This byte is the slave address, with the R/W bit LOW. The INA220 then acknowledges receipt of a valid address. The next byte transmitted by the master is the address of the register to which data will be written. This register address value updates the register pointer to the desired register. The next two bytes are written to the register addressed by the register pointer. The INA220 acknowledges receipt of each data byte. The master may terminate data transfer by generating a START or STOP condition.

When reading from the INA220, the last value stored in the register pointer by a write operation determines which register is read during a read operation. To change the register pointer for a read operation, a new value must be written to the register pointer. This write is accomplished by issuing a slave address byte with the R/W bit LOW, followed by the register pointer byte. No additional data are required. The master then generates a START condition and sends the slave address byte with the R/W bit HIGH to initiate the read command. The next byte is transmitted by the slave and is the most significant byte of the register indicated by the register pointer. This byte is followed by an *Acknowledge* from the master; then the slave transmits the least significant byte. The master acknowledges receipt of the data byte. The master may terminate data transfer by generating a *Not Acknowledge* after receiving any data byte, or generating a START or STOP condition. If repeated reads from the same register are desired, it is not necessary to continually send the register pointer bytes; the INA220 retains the register pointer value until it is changed by the next write operation.

[Figure 15](#) and [Figure 16](#) show write and read operation timing diagrams, respectively. Note that register bytes are sent most-significant byte first, followed by the least significant byte. [Figure 17](#) shows the timing diagram for the SMBus Alert response operation. [Figure 18](#) shows a typical register pointer configuration.

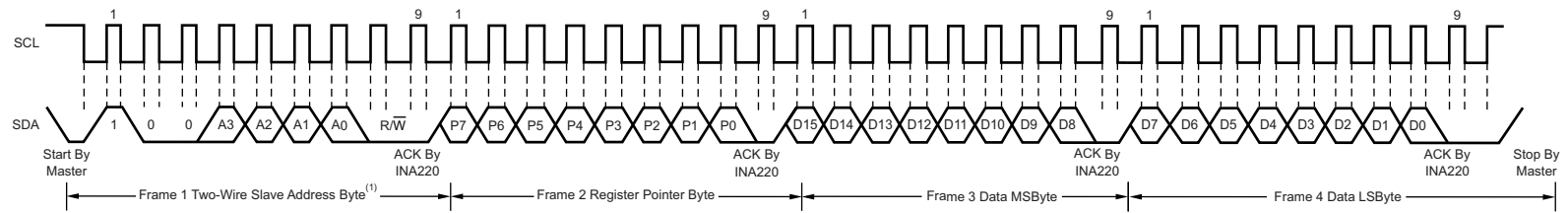

NOTE (1): The value of the Slave Address Byte is determined by the settings of the A0 and A1 pins. Refer to Table 1.

Figure 15. Timing Diagram for Write Word Format

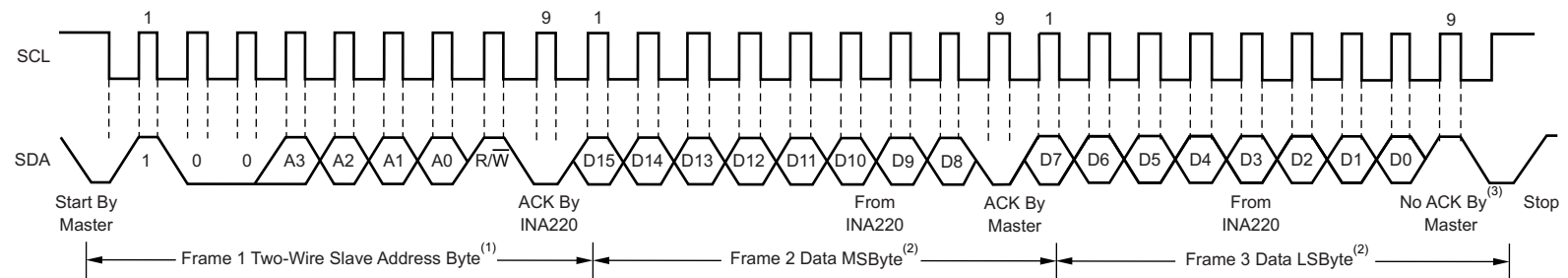

NOTES: (1) The value of the Slave Address Byte is determined by the settings of the A0 and A1 pins. Refer to Table 1.

(2) Read data is from the last register pointer location. If a new register is desired, the register pointer must be updated. See Figure 19.

(3) ACK by Master can also be sent.

Figure 16. Timing Diagram for Read Word Format

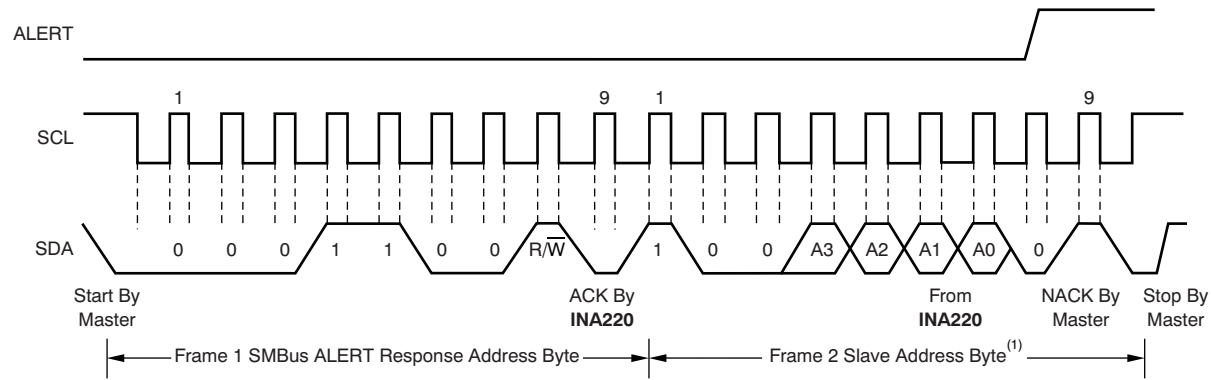

NOTE (1): The value of the Slave Address Byte is determined by the settings of the A0 and A1 pins. Refer to Table 1.

Figure 17. Timing Diagram for SMBus Alert

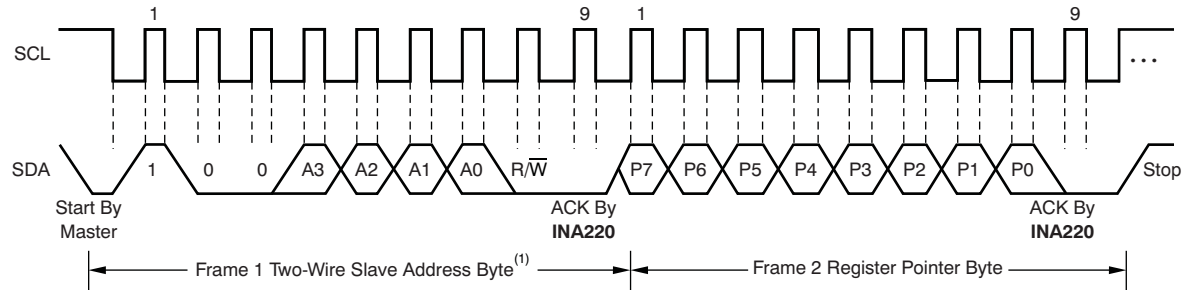

NOTE (1): The value of the Slave Address Byte is determined by the settings of the A0 and A1 pins. Refer to Table 1.

Figure 18. Typical Register Pointer Set

8.5.5.1 High-Speed Two-Wire Mode

When the bus is idle, both the SDA and SCL lines are pulled high by the pullup devices. The master generates a start condition followed by a valid serial byte containing high-speed (HS) master code *00001XXX*. This transmission is made in fast (400 kbps) or standard (100 kbps) (F/S) mode at no more than 400 kbps. The INA220 does not acknowledge the HS master code, but does recognize it and switches its internal filters to support 2.56-Mbps operation.

The master then generates a repeated start condition (a repeated start condition has the same timing as the start condition). After this repeated start condition, the protocol is the same as F/S mode, except that transmission speeds up to 2.56 Mbps are allowed. Instead of using a stop condition, repeated start conditions should be used to secure the bus in HS-mode. A STOP condition ends the HS-mode and switches all the internal filters of the INA220 to support the F/S mode. See [Bus Timing Diagram Definitions^{\(1\)}](#) and [Figure 1](#) for timing.

8.5.5.2 Power-Up Conditions

Power-up conditions apply to a software reset through the RST bit (bit 15) in the Configuration register, or the I²C bus General Call Reset.

8.6 Register Maps

8.6.1 Register Information

The INA220 uses a bank of registers for holding configuration settings, measurement results, and status information. [Table 2](#) summarizes the INA220 registers; [Functional Block Diagram](#) illustrates the registers.

Register contents are updated 4 μ s after completion of the write command. Therefore, a 4- μ s delay is required between completion of a write to a given register and a subsequent read of that register (without changing the pointer) when using SCL frequencies in excess of 1 MHz.

Table 2. Summary of Register Set

POINTER ADDRESS	REGISTER NAME	FUNCTION	POWER-ON RESET		TYPE ⁽¹⁾
			BINARY	HEX	
00	Configuration	All-register reset, settings for bus voltage range, PGA gain, ADC resolution/averaging.	00111001 10011111	399F	R/ \bar{W}
01	Shunt voltage	Shunt voltage measurement data.	Shunt voltage	—	R
02	Bus voltage	Bus voltage measurement data.	Bus voltage	—	R
03	Power ⁽²⁾	Power measurement data.	00000000 00000000	0000	R
04	Current ⁽²⁾	Contains the value of the current flowing through the shunt resistor.	00000000 00000000	0000	R
05	Calibration	Sets full-scale range and LSB of current and power measurements. Overall system calibration.	00000000 00000000	0000	R/ \bar{W}

(1) Values based on a statistical analysis of a one-time sample of devices. Minimum and maximum values are not ensured and not production tested. Condition: A0=A1=0.

(1) Type: **R** = Read only, **R/ \bar{W}** = Read/Write.

(2) The Power register and Current register default to 0 because the Calibration register defaults to 0, yielding a zero current value until the Calibration register is programmed.

8.6.2 Register Details

All INA220 registers 16-bit registers are actually two 8-bit bytes through the I²C- or SMBUS-compatible interface.

8.6.2.1 Configuration Register (address = 00h) [reset = 399Fh]

Figure 19. Configuration Register

15	14	13	12	11	10	9	8	7	6	5	4	3	2	1	0
RST	—	BRNG	PG1	PG0	BADC 4	BADC 3	BADC 2	BADC 1	SADC 4	SADC 3	SADC 2	SADC 1	MODE 3	MODE 2	MODE 1
R/W- 0	R/W- 0	R/W-1	R/W-1	R/W-1	R/W-0	R/W-0	R/W-1	R/W-1	R/W-0	R/W-0	R/W-1	R/W-1	R/W-1	R/W-1	R/W-1

LEGEND: R/W = Read/Write; R = Read only; -n = value after reset

RST: **Reset Bit**

Bit 15 Setting this bit to 1 generates a system reset that is the same as power-on reset. Resets all registers to default values; this bit self-clears.

BRNG: **Bus Voltage Range**

Bit 13 0 = 16-V FSR
1 = 32-V FSR (default value)

PG: **PGA (Shunt Voltage Only)**

Bits 11, 12 Sets PGA gain and range. Note that the PGA defaults to ÷8 (320-mV range). Table 3 shows the gain and range for the various product gain settings.

Table 3. PG Bit Settings [12:11] ⁽¹⁾

PG1	PG0	GAIN	RANGE
0	0	1	±40 mV
0	1	/2	±80 mV
1	0	/4	±160 mV
1	1	/8	±320 mV

(1) Shaded values are default.

BADC: **BADC Bus ADC Resolution/Averaging**

Bits 7–10 These bits adjust the Bus ADC resolution (9-, 10-, 11-, or 12-bit) or set the number of samples used when averaging results for the Bus Voltage Register (02h).

SADC: **SADC Shunt ADC Resolution/Averaging**

Bits 3–6 These bits adjust the Shunt ADC resolution (9-, 10-, 11-, or 12-bit) or set the number of samples used when averaging results for the Shunt Voltage Register (01h).
BADC (Bus) and SADC (Shunt) ADC resolution/averaging and conversion time settings are shown in Table 4.

Table 4. ADC Settings (SADC [6:3], BADC [10:7])⁽¹⁾

ADC4	ADC3	ADC2	ADC1	Mode/Samples	Conversion Time
0	X ⁽²⁾	0	0	9-bit	84 µs
0	X ⁽²⁾	0	1	10-bit	148 µs
0	X ⁽²⁾	1	0	11-bit	276 µs
0	X ⁽²⁾	1	1	12-bit	532 µs
1	0	0	0	12-bit	532 µs
1	0	0	1	2	1.06 ms
1	0	1	0	4	2.13 ms
1	0	1	1	8	4.26 ms
1	1	0	0	16	8.51 ms
1	1	0	1	32	17.02 ms

(1) Shaded values are default.

(2) X = Don't care

Table 4. ADC Settings (SADC [6:3], BADC [10:7])⁰ (continued)

ADC4	ADC3	ADC2	ADC1	Mode/Samples	Conversion Time
1	1	1	0	64	34.05 ms
1	1	1	1	128	68.10 ms

MODE: **Operating Mode**
 Bits 0–2 Selects continuous, triggered, or power-down mode of operation. These bits default to continuous shunt and bus measurement mode. The mode settings are shown in [Table 5](#).

Table 5. Mode Settings [2:0]⁽¹⁾

MODE3	MODE2	MODE1	MODE
0	0	0	Power-down
0	0	1	Shunt voltage, triggered
0	1	0	Bus voltage, triggered
0	1	1	Shunt and bus, triggered
1	0	0	ADC off (disabled)
1	0	1	Shunt voltage, continuous
1	1	0	Bus voltage, continuous
1	1	1	Shunt and bus, continuous

(1) Shaded values are default.

8.6.3 Data Output Registers

8.6.3.1 Shunt Voltage Register (address = 01h)

The Shunt Voltage register stores the current shunt voltage reading, V_{SHUNT} . Shunt Voltage register bits are shifted according to the PGA setting selected in the Configuration register (00h). When multiple sign bits are present, they are all the same value. Negative numbers are represented in 2's complement format. Generate the 2's complement of a negative number by complementing the absolute value binary number and adding 1. Extend the sign, denoting a negative number by setting the MSB = 1. Extend the sign to any additional sign bits to form the 16-bit word.

Example: For a value of $V_{SHUNT} = -320$ mV:

1. Take the absolute value (include accuracy to 0.01 mV) → 320.00
2. Translate this number to a whole decimal number → 32000
3. Convert it to binary → 111 1101 0000 0000
4. Complement the binary result : 000 0010 1111 1111
5. Add 1 to the complement to create the 2's-complement formatted result → 000 0011 0000 0000
6. Extend the sign and create the 16-bit word: 1000 0011 0000 0000 = 8300h (Remember to extend the sign to all sign-bits, as necessary based on the PGA setting.)

At PGA = /8, full-scale range = ±320 mV (decimal = 32000). For $V_{SHUNT} = +320$ mV, Value = 7D00h; For $V_{SHUNT} = -320$ mV, Value = 8300h; and LSB = 10 μV.

Figure 20. Shunt Voltage Register at PGA = /8

15	14	13	12	11	10	9	8	7	6	5	4	3	2	1	0
SIGN	SD14 ₈	SD13 ₈	SD12 ₈	SD11 ₈	SD10 ₈	SD9 ₈	SD8 ₈	SD7 ₈	SD6 ₈	SD5 ₈	SD4 ₈	SD3 ₈	SD2 ₈	SD1 ₈	SD0 ₈

At PGA = /4, full-scale range = ±160 mV (decimal = 16000). For $V_{SHUNT} = +160$ mV, Value = 3E80h; For $V_{SHUNT} = -160$ mV, Value = C180h; and LSB = 10 μV.

Figure 21. Shunt Voltage Register at PGA = /4

15	14	13	12	11	10	9	8	7	6	5	4	3	2	1	0
SIGN	SIGN	SD13 ₄	SD12 ₄	SD11 ₄	SD10 ₄	SD9 ₄	SD8 ₄	SD7 ₄	SD6 ₄	SD5 ₄	SD4 ₄	SD3 ₄	SD2 ₄	SD1 ₄	SD0 ₄

At PGA = /2, full-scale range = ±80 mV (decimal = 8000). For $V_{SHUNT} = +80$ mV, Value = 1F40h; For $V_{SHUNT} = -80$ mV, Value = E0C0h; and LSB = 10 μ V.

Figure 22. Shunt Voltage Register at PGA = /2

15	14	13	12	11	10	9	8	7	6	5	4	3	2	1	0
SIGN	SIGN	SIGN	SD12 ₂	SD11 ₂	SD10 ₂	SD9 ₂	SD8 ₂	SD7 ₂	SD6 ₂	SD5 ₂	SD4 ₂	SD3 ₂	SD2 ₂	SD1 ₂	SD0 ₂

At PGA = /1, full-scale range = ±40 mV (decimal = 4000). For $V_{SHUNT} = +40$ mV, Value = 0FA0h; For $V_{SHUNT} = -40$ mV, Value = F060h; and LSB = 10 μ V.

Figure 23. Shunt Voltage Register at PGA = /1

15	14	13	12	11	10	9	8	7	6	5	4	3	2	1	0
SIGN	SIGN	SIGN	SIGN	SD11 ₁	SD10 ₁	SD9 ₁	SD8 ₁	SD7 ₁	SD6 ₁	SD5 ₁	SD4 ₁	SD3 ₁	SD2 ₁	SD1 ₁	SD0 ₁

Table 6. Shunt Voltage Register Format⁽¹⁾

V _{SHUNT} Reading (mV)	Decimal Value	PGA = /8 (D15:D0)	PGA = /4 (D15:D0)	PGA = /2 (D15:D0)	PGA = /1 (D15:D0)
320.02	32002	0111 1101 0000 0000	0011 1110 1000 0000	0001 1111 0100 0000	0000 1111 1010 0000
320.01	32001	0111 1101 0000 0000	0011 1110 1000 0000	0001 1111 0100 0000	0000 1111 1010 0000
320.00	32000	0111 1101 0000 0000	0011 1110 1000 0000	0001 1111 0100 0000	0000 1111 1010 0000
319.99	31999	0111 1100 1111 1111	0011 1110 1000 0000	0001 1111 0100 0000	0000 1111 1010 0000
319.98	31998	0111 1100 1111 1110	0011 1110 1000 0000	0001 1111 0100 0000	0000 1111 1010 0000
⋮	⋮	⋮	⋮	⋮	⋮
160.02	16002	0011 1110 1000 0010	0011 1110 1000 0000	0001 1111 0100 0000	0000 1111 1010 0000
160.01	16001	0011 1110 1000 0001	0011 1110 1000 0000	0001 1111 0100 0000	0000 1111 1010 0000
160.00	16000	0011 1110 1000 0000	0011 1110 1000 0000	0001 1111 0100 0000	0000 1111 1010 0000
159.99	15999	0011 1110 0111 1111	0011 1110 0111 1111	0001 1111 0100 0000	0000 1111 1010 0000
159.98	15998	0011 1110 0111 1110	0011 1110 0111 1110	0001 1111 0100 0000	0000 1111 1010 0000
⋮	⋮	⋮	⋮	⋮	⋮
80.02	8002	0001 1111 0100 0010	0001 1111 0100 0010	0001 1111 0100 0000	0000 1111 1010 0000
80.01	8001	0001 1111 0100 0001	0001 1111 0100 0001	0001 1111 0100 0000	0000 1111 1010 0000
80.00	8000	0001 1111 0100 0000	0001 1111 0100 0000	0001 1111 0100 0000	0000 1111 1010 0000
79.99	7999	0001 1111 0011 1111	0001 1111 0011 1111	0001 1111 0011 1111	0000 1111 1010 0000
79.98	7998	0001 1111 0011 1110	0001 1111 0011 1110	0001 1111 0011 1110	0000 1111 1010 0000
⋮	⋮	⋮	⋮	⋮	⋮
40.02	4002	0000 1111 1010 0010	0000 1111 1010 0010	0000 1111 1010 0010	0000 1111 1010 0000
40.01	4001	0000 1111 1010 0001	0000 1111 1010 0001	0000 1111 1010 0001	0000 1111 1010 0000
40.00	4000	0000 1111 1010 0000	0000 1111 1010 0000	0000 1111 1010 0000	0000 1111 1010 0000
39.99	3999	0000 1111 1001 1111	0000 1111 1001 1111	0000 1111 1001 1111	0000 1111 1001 1111
39.98	3998	0000 1111 1001 1110	0000 1111 1001 1110	0000 1111 1001 1110	0000 1111 1001 1110
⋮	⋮	⋮	⋮	⋮	⋮
0.02	2	0000 0000 0000 0010	0000 0000 0000 0010	0000 0000 0000 0010	0000 0000 0000 0010
0.01	1	0000 0000 0000 0001	0000 0000 0000 0001	0000 0000 0000 0001	0000 0000 0000 0001
0	0	0000 0000 0000 0000	0000 0000 0000 0000	0000 0000 0000 0000	0000 0000 0000 0000
-0.01	-1	1111 1111 1111 1111	1111 1111 1111 1111	1111 1111 1111 1111	1111 1111 1111 1111
-0.02	-2	1111 1111 1111 1110	1111 1111 1111 1110	1111 1111 1111 1110	1111 1111 1111 1110
⋮	⋮	⋮	⋮	⋮	⋮
-39.98	-3998	1111 0000 0110 0010	1111 0000 0110 0010	1111 0000 0110 0010	1111 0000 0110 0010
-39.99	-3999	1111 0000 0110 0001	1111 0000 0110 0001	1111 0000 0110 0001	1111 0000 0110 0001
-40.00	-4000	1111 0000 0110 0000	1111 0000 0110 0000	1111 0000 0110 0000	1111 0000 0110 0000
-40.01	-4001	1111 0000 0101 1111	1111 0000 0101 1111	1111 0000 0101 1111	1111 0000 0110 0000
-40.02	-4002	1111 0000 0101 1110	1111 0000 0101 1110	1111 0000 0101 1110	1111 0000 0110 0000
⋮	⋮	⋮	⋮	⋮	⋮
-79.98	-7998	1110 0000 1100 0010	1110 0000 1100 0010	1110 0000 1100 0010	1111 0000 0110 0000
-79.99	-7999	1110 0000 1100 0001	1110 0000 1100 0001	1110 0000 1100 0001	1111 0000 0110 0000
-80.00	-8000	1110 0000 1100 0000	1110 0000 1100 0000	1110 0000 1100 0000	1111 0000 0110 0000
-80.01	-8001	1110 0000 1011 1111	1110 0000 1011 1111	1110 0000 1100 0000	1111 0000 0110 0000
-80.02	-8002	1110 0000 1011 1110	1110 0000 1011 1110	1110 0000 1100 0000	1111 0000 0110 0000
⋮	⋮	⋮	⋮	⋮	⋮
-159.98	-15998	1100 0001 1000 0010	1100 0001 1000 0010	1110 0000 1100 0000	1111 0000 0110 0000
-159.99	-15999	1100 0001 1000 0001	1100 0001 1000 0001	1110 0000 1100 0000	1111 0000 0110 0000
-160.00	-16000	1100 0001 1000 0000	1100 0001 1000 0000	1110 0000 1100 0000	1111 0000 0110 0000
-160.01	-16001	1100 0001 0111 1111	1100 0001 1000 0000	1110 0000 1100 0000	1111 0000 0110 0000
-160.02	-16002	1100 0001 0111 1110	1100 0001 1000 0000	1110 0000 1100 0000	1111 0000 0110 0000
⋮	⋮	⋮	⋮	⋮	⋮
-319.98	-31998	1000 0011 0000 0010	1100 0001 1000 0000	1110 0000 1100 0000	1111 0000 0110 0000
-319.99	-31999	1000 0011 0000 0001	1100 0001 1000 0000	1110 0000 1100 0000	1111 0000 0110 0000
-320.00	-32000	1000 0011 0000 0000	1100 0001 1000 0000	1110 0000 1100 0000	1111 0000 0110 0000
-320.01	-32001	1000 0011 0000 0000	1100 0001 1000 0000	1110 0000 1100 0000	1111 0000 0110 0000
-320.02	-32002	1000 0011 0000 0000	1100 0001 1000 0000	1110 0000 1100 0000	1111 0000 0110 0000

(1) Out-of-range values are shown in gray shading.

8.6.3.2 Bus Voltage Register (address = 02h)

The Bus Voltage register stores the most recent bus voltage reading, V_{BUS} .

At full-scale range = 32 V (decimal = 8000, hex = 1F40), and LSB = 4 mV.

Figure 24. Bus Voltage Register (BRNG = 1)

15	14	13	12	11	10	9	8	7	6	5	4	3	2	1	0
BD12	BD11	BD10	BD9	BD8	BD7	BD6	BD5	BD4	BD3	BD2	BD1	BD0	—	CNVR	OVF

At full-scale range = 16 V (decimal = 4000, hex = 0FA0), and LSB = 4 mV.

Figure 25. Bus Voltage Register (BRNG = 0)

15	14	13	12	11	10	9	8	7	6	5	4	3	2	1	0
0	BD11	BD10	BD9	BD8	BD7	BD6	BD5	BD4	BD3	BD2	BD1	BD0	—	CNVR	OVF

CNVR: Conversion Ready

Bit 1

Although the data from the last conversion can be read at any time, the INA220 Conversion Ready bit (CNVR) indicates when data from a conversion is available in the data output registers. The CNVR bit is set after all conversions, averaging, and multiplications are complete. CNVR will clear under the following conditions:

- 1.) Writing a new mode into the Operating Mode bits in the Configuration Register (except for Power-Down or Disable)
- 2.) Reading the Power Register

OVF: Math Overflow Flag

Bit 0

The Math Overflow Flag (OVF) is set when the Power or Current calculations are out of range. It indicates that current and power data may be meaningless.

8.6.3.3 Power Register (address = 03h) [reset = 00h]

Full-scale range and LSB are set by the Calibration register. See [Programming the INA220 Calibration Register](#).

Figure 26. Power Register

15	14	13	12	11	10	9	8	7	6	5	4	3	2	1	0
PD15	PD14	PD13	PD12	PD11	PD10	PD9	PD8	PD7	PD6	PD5	PD4	PD3	PD2	PD1	PD0
R-0	R-0	R-0	R-0	R-0	R-0	R-0	R-0	R-0	R-0	R-0	R-0	R-0	R-0	R-0	R-0

LEGEND: R/W = Read/Write; R = Read only; -n = value after reset

The Power register records power in watts by multiplying the values of the current with the value of the bus voltage according to the [Equation 5](#):

8.6.3.4 Current Register (address = 04h) [reset = 00h]

Full-scale range and LSB depend on the value entered in the Calibration register. See [Programming the INA220 Calibration Register](#). Negative values are stored in 2's complement format.

Figure 27. Current Register

15	14	13	12	11	10	9	8	7	6	5	4	3	2	1	0
CSIGN	CD14	CD13	CD12	CD11	CD10	CD9	CD8	CD7	CD6	CD5	CD4	CD3	CD2	CD1	CD0
R-0	R-0	R-0	R-0	R-0	R-0	R-0	R-0	R-0	R-0	R-0	R-0	R-0	R-0	R-0	R-0

LEGEND: R/W = Read/Write; R = Read only; -n = value after reset

The value of the Current register is calculated by multiplying the value in the Shunt Voltage register with the value in the Calibration register according to the [Equation 4](#).

8.6.4 Calibration Register

8.6.4.1 Calibration Register (address = 05h) [reset = 00h]

Current and power calibration are set by bits FS15 to FS1 of the Calibration register. Note that bit FS0 is not used in the calculation. This register sets the current that corresponds to a full-scale drop across the shunt. Full-scale range and the LSB of the current and power measurement depend on the value entered in this register. See the [Programming the INA220 Calibration Register](#). This register is suitable for use in overall system calibration. Note that the 0 POR values are all default.

Figure 28. Calibration Register⁽¹⁾

15	14	13	12	11	10	9	8	7	6	5	4	3	2	1	0
FS15	FS14	FS13	FS12	FS11	FS10	FS9	FS8	FS7	FS6	FS5	FS4	FS3	FS2	FS1	FS0
R/W-0	R/W-0	R/W-0	R/W-0	R/W-0	R/W-0	R/W-0	R/W-0	R/W-0	R/W-0	R/W-0	R/W-0	R/W-0	R/W-0	R/W-0	R-0

LEGEND: R/W = Read/Write; R = Read only; -n = value after reset

(1) FS0 is a *void* bit and will always be 0. It is not possible to write a 1 to FS0. CALIBRATION is the value stored in FS15:FS1.

9 Application and Implementation

NOTE

Information in the following applications sections is not part of the TI component specification, and TI does not warrant its accuracy or completeness. TI's customers are responsible for determining suitability of components for their purposes. Customers should validate and test their design implementation to confirm system functionality.

9.1 Application Information

The INA220 is a digital current-shunt monitor with an I²C- and SMBus-compatible interface. It provides digital current, voltage, and power readings necessary for accurate decision-making in precisely-controlled systems. Programmable registers allow flexible configuration for measurement resolution, and continuous-versus-triggered operation. See Table 2 for detailed register information. See Figure 29 for a block diagram of the INA220.

9.2 Typical Application

Figure 29 shows a typical application circuit for the INA220. Use a 0.1- μ F ceramic capacitor for power-supply bypassing, placed as closely as possible to the supply and ground pins.

The input filter circuit consisting of R_{F1} , R_{F2} , and C_F is not necessary in most applications. If the need for filtering is unknown, reserve board space for the components and install 0- Ω resistors unless a filter is needed. See [Filtering and Input Considerations](#).

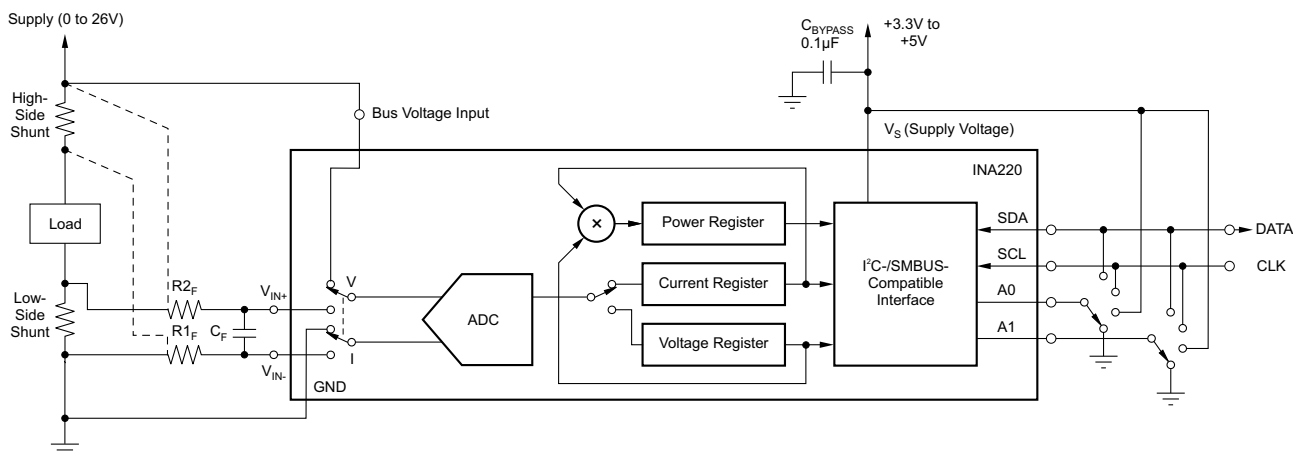

Figure 29. General Load, Low- or High-Side Sensing

9.2.1 Design Requirements

The INA220 measures the voltage across a current-sensing resistor (R_{SHUNT}) when current passes through the resistor. The device also measures the bus supply voltage, and calculates power when calibrated. This section goes through the steps to program the device for power measurements, and shows the register results in Table 7. The Conditions for the example circuit is: Maximum expected load current = 15 A, Nominal load current = 10 A, $V_{CM} = 12$ V, $R_{SHUNT} = 2$ m Ω , $V_{SHUNT} FSR = 40$ mV ($PGA = /1$), and $BRNG = 0$ (V_{BUS} range = 16 V).

9.2.2 Detailed Design Procedure

In this example, the 10-A load creates a differential voltage of 20 mV across a 2-m Ω shunt resistor. The voltage present at the IN- pin is equal to the common-mode voltage minus the differential drop across the resistor. The bus voltage for the INA220 is measured at the external VBUS input pin, which in this example is connected to the IN- pin to measure the voltage level delivered to the load. For this example, the voltage at the IN- pin is 11.98 V. For this particular range (40-mV full-scale), this small difference is not a significant deviation from the 12-V common-mode voltage. However, at larger full-scale ranges, this deviation can be much larger.

Typical Application (continued)

Note that the Bus Voltage register bits are not right-aligned. To compute the value of the Bus Voltage register contents using the LSB of 4 mV, the register must be shifted right by three bits. This shift puts the BD0 bit in the LSB position so that the contents can be multiplied by the 4-mV LSB value to compute the bus voltage measured by the device. The shifted value of the bus voltage register contents is now equal to BB3h, a decimal equivalent of 2995. This value of 2995 multiplied by the 4-mV LSB results in a value of 11.98 V.

The Calibration register (05h) is set to provide the device information about the current shunt resistor that was used to create the measured shunt voltage. By knowing the value of the shunt resistor, the device can then calculate the amount of current that created the measured shunt voltage drop. The first step when calculating the calibration value is setting the current LSB. The Calibration register value is based on a calculation that has its precision capability limited by the size of the register and the Current register LSB. The device can measure bidirectional current; thus, the MSB of the Current register is a sign bit that allows for the rest of the 15 bits to be used for the Current register value. For this example, the minimum current LSB would be $457.78 \mu\text{A/bit}$ assuming a maximum expected current of 15 A using Equation 2. For this example, a value of 1 mA/bit was chosen for the current LSB. Setting the current LSB to this value allows for sufficient precision while serving to simplify the math as well. Using Equation 1 results in a Calibration register value of 20480 or 5000h.

The Current register (04h) is internally calculated by multiplying the shunt voltage contents by the Calibration register and then dividing by 4096 using Equation 4. For this example, the shunt voltage of 2000 is multiplied by the Calibration register of 20480 and then divided by 4096 to yield a Current register value of 10000 (2710h).

The Power register (03h) is internally calculated by multiplying the Current register value of 10000 by the Bus Voltage register value of 2995 and then dividing by 5000 using Equation 5. For this example, the Power register contents are 5990 (1766h). Multiplying this result by the power LSB that is 20 times the 1×10^{-3} current LSB, or 20×10^{-3} , results in a power calculation of $5990 \times 20 \text{ mW/bit}$, which equals 119.8 W. This result matches what is expected for this register. A manual calculation for the power being delivered to the load would use 11.98 V (12 VCM – 20 mV shunt drop) multiplied by the load current of 10 A to give a 119.8-W result.

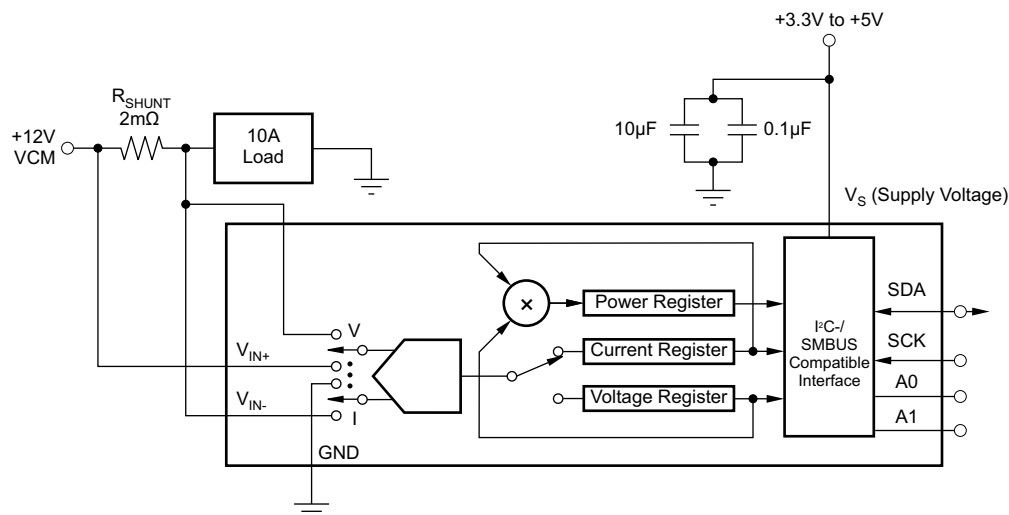

Figure 30. Example Circuit Configuration

Typical Application (continued)

9.2.2.1 Register Results for the Example Circuit

Table 7 shows the register readings for the Calibration example.

Table 7. Register Results⁽¹⁾

REGISTER NAME	ADDRESS	CONTENTS	ADJ	DEC	LSB	VALUE
Configuration	00h	019Fh				
Shunt	01h	07D0h		2000	10 μ V	20 mV
Bus	02h	5D98h	0BB3	2995	4 mV	11.98 V
Calibration	05h	5000h		20480		
Current	04h	2710h		10000	1 mA	10.0 A
Power	03h	1766h		5990	20 mW	119.8 W

(1) Conditions: load = 10 A, $V_{CM} = 12$ V, $R_{SHUNT} = 2$ m Ω , V_{SHUNT} FSR = 40 mV, and $V_{BUS} = 16$ V.

9.2.3 Typical Application: –48-V Telecom Current/Voltage/Power Sense With Isolation

Figure 31, Figure 32, and Figure 33 show the INA220 in additional circuit configurations for current, voltage, and power monitoring applications.

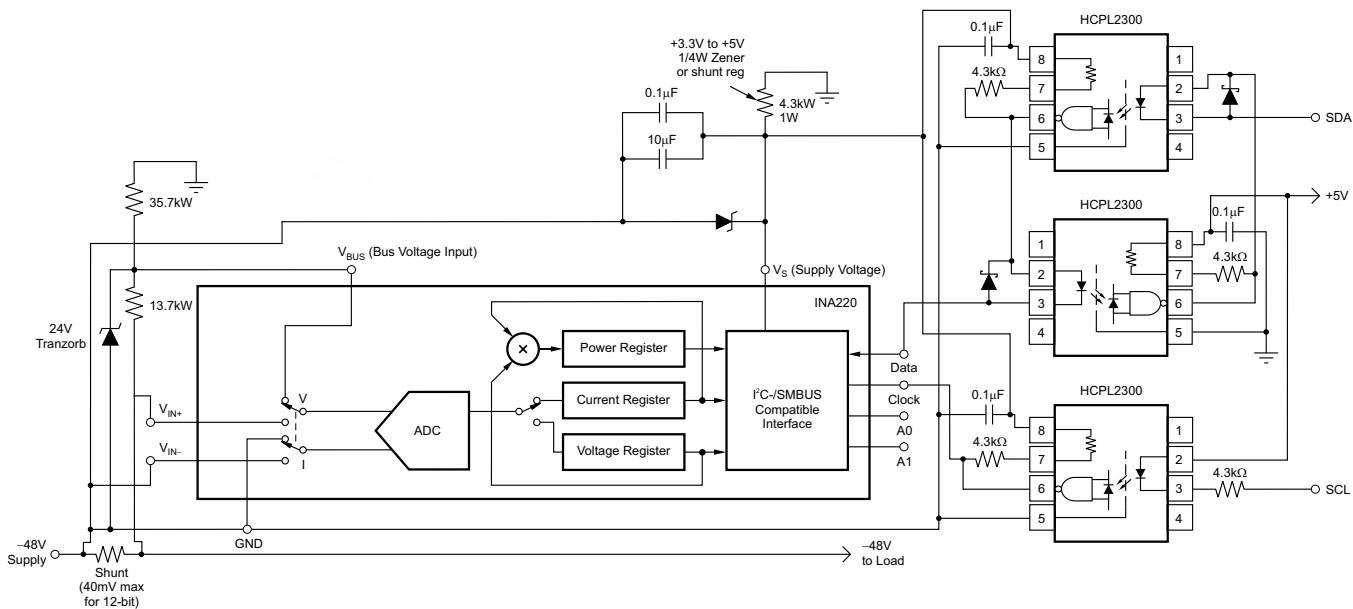

Figure 31. –48-V Telecom Current/Voltage/Power Sense With Isolation

9.2.4 Typical Application: 48-V Telecom Current/Voltage/Power Sense

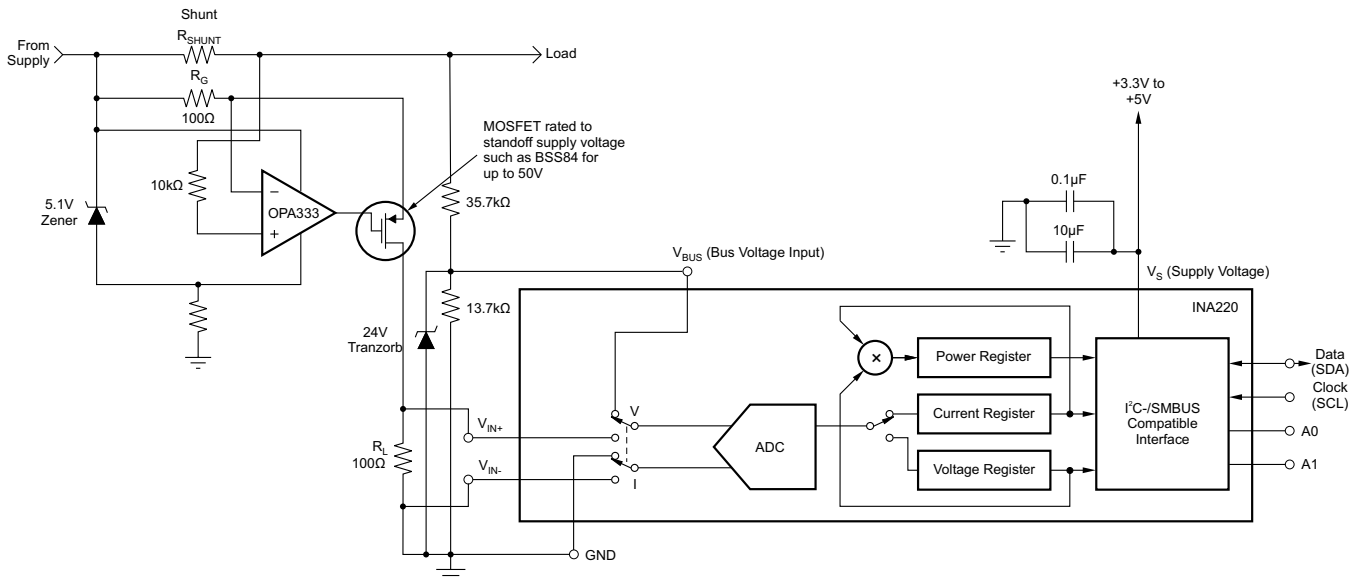

Figure 32. 48-V Telecom Current/Voltage/Power Sense

9.2.5 Typical Application: General Source Low-Side Sensing

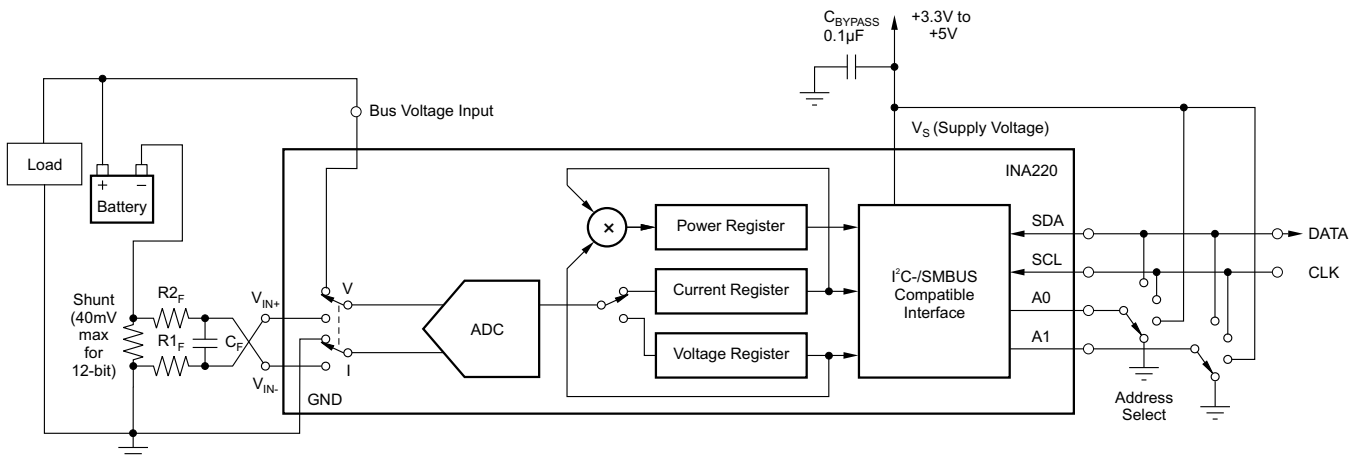

Figure 33. General Source Low-Side Sensing

10 Power Supply Recommendations

The input circuitry of the device can accurately measure signals on common-mode voltages beyond its power supply voltage, V_S . For example, the voltage applied to the V_S power supply terminal can be 5 V, whereas the load power-supply voltage being monitored (the common-mode voltage) can be as high as 26 V. Note also that the device can withstand the full 0-V to 26-V range at the input terminals, regardless of whether the device has power applied or not. Place the required power-supply bypass capacitors as close as possible to the supply and ground terminals of the device to ensure stability. A typical value for this supply bypass capacitor is 0.1 μF . Applications with noisy or high-impedance power supplies may require additional decoupling capacitors to reject power-supply noise.

11 Layout

11.1 Layout Guidelines

Connect the input pins (IN+ and IN–) to the sensing resistor using a Kelvin connection or a 4-wire connection. These connection techniques ensure that only the current-sensing resistor impedance is detected between the input pins. Poor routing of the current-sensing resistor commonly results in additional resistance present between the input pins. Given the very low ohmic value of the current-sensing resistor, any additional high-current carrying impedance causes significant measurement errors. Place the power-supply bypass capacitor as close as possible to the supply and ground pins.

11.2 Layout Example

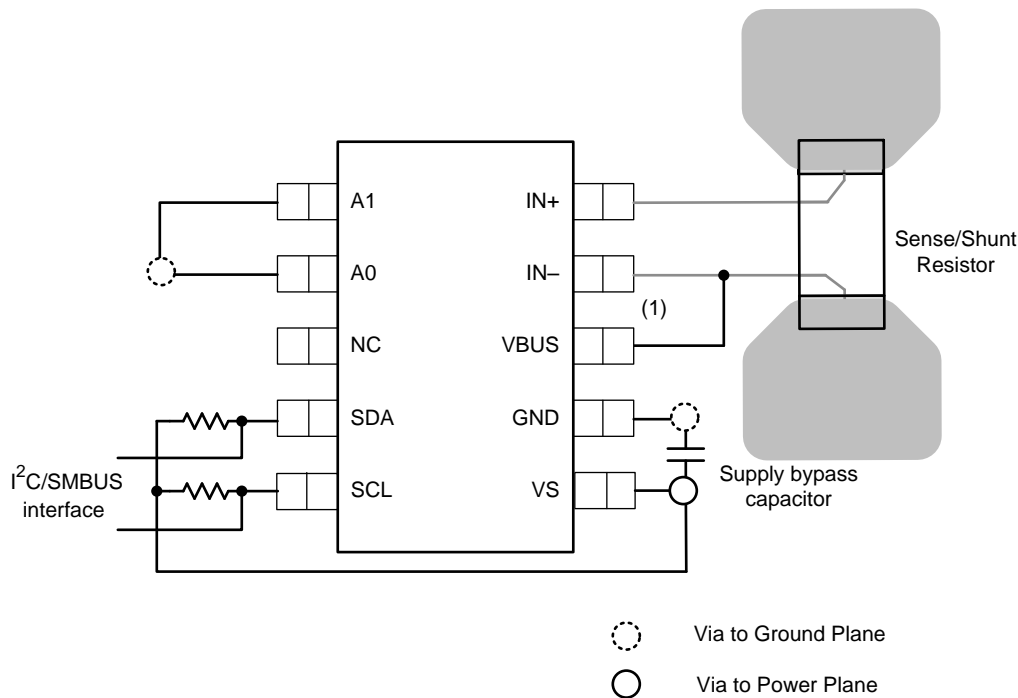

(1) Connect the VBUS pin to the power supply rail

Figure 34. Layout Recommendation

12 デバイスおよびドキュメントのサポート

12.1 関連資料

関連資料については、『[TPS2490/1 正の高電圧の電力制限ホットスワップ・コントローラ](#)』データシート(SLV5503)を参照してください。

12.2 コミュニティ・リソース

The following links connect to TI community resources. Linked contents are provided "AS IS" by the respective contributors. They do not constitute TI specifications and do not necessarily reflect TI's views; see TI's [Terms of Use](#).

TI E2E™オンライン・コミュニティ *TIのE2E (Engineer-to-Engineer) コミュニティ*。エンジニア間の共同作業を促進するために開設されたものです。e2e.ti.comでは、他のエンジニアに質問し、知識を共有し、アイデアを検討して、問題解決に役立てることができます。

設計サポート *TIの設計サポート* 役に立つE2Eフォーラムや、設計サポート・ツールをすばやく見つけることができます。技術サポート用の連絡先情報も参照できます。

12.3 商標

E2E is a trademark of Texas Instruments.
All other trademarks are the property of their respective owners.

12.4 静電気放電に関する注意事項



これらのデバイスは、限定的なESD(静電破壊)保護機能を内蔵しています。保存時または取り扱い時は、MOSゲートに対する静電破壊を防止するために、リード線同士をショートさせておくか、デバイスを導電フォームに入れる必要があります。

12.5 用語集

SLYZ022 — *TI用語集*。

この用語集には、用語や略語の一覧および定義が記載されています。

13 メカニカル、パッケージ、および注文情報

以降のページには、メカニカル、パッケージ、および注文に関する情報が記載されています。この情報は、そのデバイスについて利用可能な最新のデータです。このデータは予告なく変更されることがあり、ドキュメントが改訂される場合もあります。本データシートのブラウザ版を使用されている場合は、画面左側の説明をご覧ください。

PACKAGING INFORMATION

Orderable Device	Status (1)	Package Type	Package Drawing	Pins	Package Qty	Eco Plan (2)	Lead finish/ Ball material (6)	MSL Peak Temp (3)	Op Temp (°C)	Device Marking (4/5)	Samples
INA220AIDGSR	ACTIVE	VSSOP	DGS	10	2500	RoHS & Green	NIPDAU NIPDAUAG	Level-2-260C-1 YEAR	-40 to 125	OOUI	Samples
INA220AIDGST	LIFEBUY	VSSOP	DGS	10	250	RoHS & Green	NIPDAU NIPDAUAG	Level-2-260C-1 YEAR	-40 to 125	OOUI	
INA220BIDGSR	ACTIVE	VSSOP	DGS	10	2500	RoHS & Green	NIPDAU NIPDAUAG	Level-2-260C-1 YEAR	-40 to 125	ZAEI	Samples
INA220BIDGST	LIFEBUY	VSSOP	DGS	10	250	RoHS & Green	NIPDAU NIPDAUAG	Level-2-260C-1 YEAR	-40 to 125	ZAEI	

(1) The marketing status values are defined as follows:

ACTIVE: Product device recommended for new designs.

LIFEBUY: TI has announced that the device will be discontinued, and a lifetime-buy period is in effect.

NRND: Not recommended for new designs. Device is in production to support existing customers, but TI does not recommend using this part in a new design.

PREVIEW: Device has been announced but is not in production. Samples may or may not be available.

OBSOLETE: TI has discontinued the production of the device.

(2) **RoHS:** TI defines "RoHS" to mean semiconductor products that are compliant with the current EU RoHS requirements for all 10 RoHS substances, including the requirement that RoHS substance do not exceed 0.1% by weight in homogeneous materials. Where designed to be soldered at high temperatures, "RoHS" products are suitable for use in specified lead-free processes. TI may reference these types of products as "Pb-Free".

RoHS Exempt: TI defines "RoHS Exempt" to mean products that contain lead but are compliant with EU RoHS pursuant to a specific EU RoHS exemption.

Green: TI defines "Green" to mean the content of Chlorine (Cl) and Bromine (Br) based flame retardants meet JS709B low halogen requirements of <=1000ppm threshold. Antimony trioxide based flame retardants must also meet the <=1000ppm threshold requirement.

(3) MSL, Peak Temp. - The Moisture Sensitivity Level rating according to the JEDEC industry standard classifications, and peak solder temperature.

(4) There may be additional marking, which relates to the logo, the lot trace code information, or the environmental category on the device.

(5) Multiple Device Markings will be inside parentheses. Only one Device Marking contained in parentheses and separated by a "~" will appear on a device. If a line is indented then it is a continuation of the previous line and the two combined represent the entire Device Marking for that device.

(6) Lead finish/Ball material - Orderable Devices may have multiple material finish options. Finish options are separated by a vertical ruled line. Lead finish/Ball material values may wrap to two lines if the finish value exceeds the maximum column width.

Important Information and Disclaimer:The information provided on this page represents TI's knowledge and belief as of the date that it is provided. TI bases its knowledge and belief on information provided by third parties, and makes no representation or warranty as to the accuracy of such information. Efforts are underway to better integrate information from third parties. TI has taken and continues to take reasonable steps to provide representative and accurate information but may not have conducted destructive testing or chemical analysis on incoming materials and chemicals. TI and TI suppliers consider certain information to be proprietary, and thus CAS numbers and other limited information may not be available for release.

In no event shall TI's liability arising out of such information exceed the total purchase price of the TI part(s) at issue in this document sold by TI to Customer on an annual basis.

OTHER QUALIFIED VERSIONS OF INA220 :

- Automotive : [INA220-Q1](#)

NOTE: Qualified Version Definitions:

- Automotive - Q100 devices qualified for high-reliability automotive applications targeting zero defects

TAPE AND REEL INFORMATION



QUADRANT ASSIGNMENTS FOR PIN 1 ORIENTATION IN TAPE



*All dimensions are nominal

Device	Package Type	Package Drawing	Pins	SPQ	Reel Diameter (mm)	Reel Width W1 (mm)	A0 (mm)	B0 (mm)	K0 (mm)	P1 (mm)	W (mm)	Pin1 Quadrant
INA220AIDGSR	VSSOP	DGS	10	2500	330.0	12.4	5.3	3.4	1.4	8.0	12.0	Q1
INA220AIDGSR	VSSOP	DGS	10	2500	330.0	12.4	5.3	3.3	1.3	8.0	12.0	Q1
INA220AIDGST	VSSOP	DGS	10	250	330.0	12.4	5.3	3.4	1.4	8.0	12.0	Q1
INA220AIDGST	VSSOP	DGS	10	250	180.0	12.4	5.3	3.3	1.3	8.0	12.0	Q1
INA220BIDGSR	VSSOP	DGS	10	2500	330.0	12.4	5.3	3.4	1.4	8.0	12.0	Q1
INA220BIDGSR	VSSOP	DGS	10	2500	330.0	12.4	5.3	3.3	1.3	8.0	12.0	Q1
INA220BIDGST	VSSOP	DGS	10	250	180.0	12.4	5.3	3.3	1.3	8.0	12.0	Q1
INA220BIDGST	VSSOP	DGS	10	250	330.0	12.4	5.3	3.4	1.4	8.0	12.0	Q1

TAPE AND REEL BOX DIMENSIONS

*All dimensions are nominal

Device	Package Type	Package Drawing	Pins	SPQ	Length (mm)	Width (mm)	Height (mm)
INA220AIDGSR	VSSOP	DGS	10	2500	366.0	364.0	50.0
INA220AIDGSR	VSSOP	DGS	10	2500	367.0	367.0	38.0
INA220AIDGST	VSSOP	DGS	10	250	366.0	364.0	50.0
INA220AIDGST	VSSOP	DGS	10	250	213.0	191.0	35.0
INA220BIDGSR	VSSOP	DGS	10	2500	366.0	364.0	50.0
INA220BIDGSR	VSSOP	DGS	10	2500	367.0	367.0	38.0
INA220BIDGST	VSSOP	DGS	10	250	213.0	191.0	35.0
INA220BIDGST	VSSOP	DGS	10	250	366.0	364.0	50.0

DGS0010A

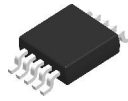

PACKAGE OUTLINE

VSSOP - 1.1 mm max height

SMALL OUTLINE PACKAGE



4221984/A 05/2015

NOTES:

1. All linear dimensions are in millimeters. Any dimensions in parenthesis are for reference only. Dimensioning and tolerancing per ASME Y14.5M.
2. This drawing is subject to change without notice.
3. This dimension does not include mold flash, protrusions, or gate burrs. Mold flash, protrusions, or gate burrs shall not exceed 0.15 mm per side.
4. This dimension does not include interlead flash. Interlead flash shall not exceed 0.25 mm per side.
5. Reference JEDEC registration MO-187, variation BA.

EXAMPLE BOARD LAYOUT

DGS0010A

VSSOP - 1.1 mm max height

SMALL OUTLINE PACKAGE



LAND PATTERN EXAMPLE
SCALE:10X

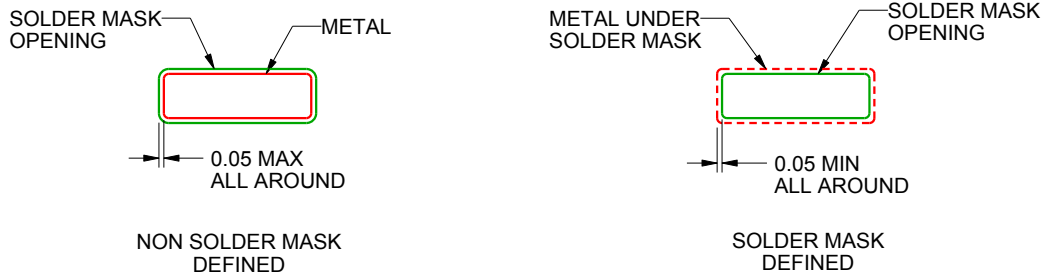

SOLDER MASK DETAILS
NOT TO SCALE

4221984/A 05/2015

NOTES: (continued)

- 6. Publication IPC-7351 may have alternate designs.
- 7. Solder mask tolerances between and around signal pads can vary based on board fabrication site.

EXAMPLE STENCIL DESIGN

DGS0010A

VSSOP - 1.1 mm max height

SMALL OUTLINE PACKAGE



SOLDER PASTE EXAMPLE
BASED ON 0.125 mm THICK STENCIL
SCALE:10X

4221984/A 05/2015

NOTES: (continued)

8. Laser cutting apertures with trapezoidal walls and rounded corners may offer better paste release. IPC-7525 may have alternate design recommendations.
9. Board assembly site may have different recommendations for stencil design.

重要なお知らせと免責事項

テキサス・インスツルメンツは、技術データと信頼性データ(データシートを含みます)、設計リソース(リファレンス デザインを含みます)、アプリケーションや設計に関する各種アドバイス、Web ツール、安全性情報、その他のリソースを、欠陥が存在する可能性のある「現状のまま」提供しており、商品性および特定目的に対する適合性の黙示保証、第三者の知的財産権の非侵害保証を含むいかなる保証も、明示的または黙示的にかかわらず拒否します。

これらのリソースは、テキサス・インスツルメンツ製品を使用する設計の経験を積んだ開発者への提供を意図したものです。(1) お客様のアプリケーションに適したテキサス・インスツルメンツ製品の選定、(2) お客様のアプリケーションの設計、検証、試験、(3) お客様のアプリケーションに該当する各種規格や、その他のあらゆる安全性、セキュリティ、規制、または他の要件への確実な適合に関する責任を、お客様のみが単独で負うものとし、ます。

上記の各種リソースは、予告なく変更される可能性があります。これらのリソースは、リソースで説明されているテキサス・インスツルメンツ製品を使用するアプリケーションの開発の目的でのみ、テキサス・インスツルメンツはその使用をお客様に許諾します。これらのリソースに関して、他の目的で複製することや掲載することは禁止されています。テキサス・インスツルメンツや第三者の知的財産権のライセンスが付与されている訳ではありません。お客様は、これらのリソースを自身で使用した結果発生するあらゆる申し立て、損害、費用、損失、責任について、テキサス・インスツルメンツおよびその代理人を完全に補償するものとし、テキサス・インスツルメンツは一切の責任を拒否します。

テキサス・インスツルメンツの製品は、[テキサス・インスツルメンツの販売条件](#)、または [ti.com](https://www.ti.com) やかかるテキサス・インスツルメンツ製品の関連資料などのいずれかを通じて提供する適用可能な条項の下で提供されています。テキサス・インスツルメンツがこれらのリソースを提供することは、適用されるテキサス・インスツルメンツの保証または他の保証の放棄の拡大や変更を意味するものではありません。

お客様がいかなる追加条項または代替条項を提案した場合でも、テキサス・インスツルメンツはそれらに異議を唱え、拒否します。

郵送先住所：Texas Instruments, Post Office Box 655303, Dallas, Texas 75265
Copyright © 2025, Texas Instruments Incorporated