

## INA300 過電流保護、電流センシング・コンパレータ

### 1 特長

- 広い同相電圧範囲: 0V~36V
- 応答時間を選択可能:
  - 10 $\mu$ s、50 $\mu$ s、100 $\mu$ s
- スレッシュホールドをプログラム可能:
  - 1つの抵抗を使って設定
  - 0mV~250mVの範囲でプログラム可能
- 精度:
  - オフセット電圧:  $\pm 500\mu$ V以下
  - オフセット電圧ドリフト: 0.5 $\mu$ V/°C以下
- ヒステリシスを選択可能:
  - 2mV、4mV、8mV
- アクティブ時の静止電流: 135 $\mu$ A以下
- ディスエーブル・モードを選択可能
  - ディスエーブル時の静止電流: 3.5 $\mu$ A以下
  - ディスエーブル時の入力バイアス電流: 500nA以下
- ラッチ・モード付きのオープン・ドレイン出力が利用可能

### 2 アプリケーション

- 過電流保護
- コンピュータ
- サーバー
- 通信機器
- 電源
- バッテリ充電器

### 3 概要

過電流保護アプリケーション向けに設計された INA300 は、シャント抵抗の両端に発生する電圧を測定し、その電圧をスレッシュホールド電圧入力レベルと比較することで過電流を検出する電流センシング・コンパレータです。このデバイスは、電源電圧にかかわらず、0V~36Vの同相電圧で差動電圧信号を測定できます。INA300 デバイスは、外付けの制限設定抵抗 1 つで、スレッシュホールド範囲を設定できます。ヒステリシスを選択できるため、0mV~250mVの広い入力信号範囲に合わせてコンパレータの動作を調整できます。

デバイスにはオープン・ドレインのアラート出力があり、透過モード (出力ステータスが入力状態に従う) またはラッチ・モード (ラッチがクリアされたときにアラート出力がクリアされる) で動作するよう構成できます。デバイスの応答時間を選択可能なため、過電流アラートは最短では 10 $\mu$ s で発行できます。

INA300 デバイスは 2.7V~5.5V の単一電源で動作し、最大消費電流は 135 $\mu$ A です。INA300 デバイスは拡張動作温度範囲の -40°C~+125°C で動作が規定されており、WSO-10 および VSSOP-10 パッケージで供給されます。

#### 製品情報

部品番号	パッケージ <sup>(1)</sup>	本体サイズ (公称)
INA300	WSO-10	2.00mm × 2.00mm
	VSSOP-10	3.00mm × 3.00mm

- (1) 提供されているすべてのパッケージについては、データシートの末尾にあるパッケージ・オプションについての付録を参照してください。

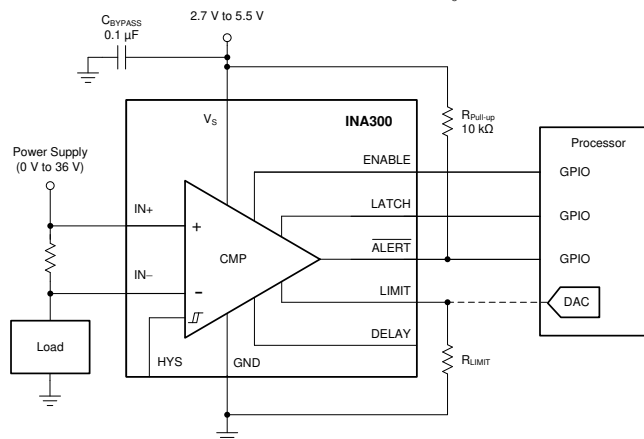

代表的なアプリケーション回路図



## Table of Contents

<b>1 特長</b> .....	1	7.4 Device Functional Modes.....	18
<b>2 アプリケーション</b> .....	1	<b>8 Application and Implementation</b> .....	22
<b>3 概要</b> .....	1	8.1 Application Information.....	22
<b>4 Revision History</b> .....	2	8.2 Typical Applications.....	22
<b>5 Pin Configuration and Functions</b> .....	3	<b>9 Power Supply Recommendations</b> .....	28
<b>6 Specifications</b> .....	4	<b>10 Layout</b> .....	29
6.1 Absolute Maximum Ratings <sup>(1)</sup> .....	4	10.1 Layout Guidelines.....	29
6.2 ESD Ratings.....	4	10.2 Layout Example.....	30
6.3 Recommended Operating Conditions.....	4	<b>11 Device and Documentation Support</b> .....	32
6.4 Thermal Information.....	4	11.1 Documentation Support.....	32
6.5 Electrical Characteristics.....	5	11.2 Receiving Notification of Documentation Updates..	32
6.6 Timing Requirements.....	5	11.3 サポート・リソース.....	32
6.7 Typical Characteristics.....	6	11.4 Trademarks.....	32
<b>7 Detailed Description</b> .....	10	11.5 Electrostatic Discharge Caution.....	32
7.1 Overview.....	10	11.6 Glossary.....	32
7.2 Functional Block Diagram.....	10	<b>12 Mechanical, Packaging, and Orderable Information</b> .....	32
7.3 Feature Description.....	10		

## 4 Revision History

資料番号末尾の英字は改訂を表しています。その改訂履歴は英語版に準じています。

<b>Changes from Revision B (April 2016) to Revision C (June 2021)</b>	<b>Page</b>
• Changed  7-6 caption.....	16

---

<b>Changes from Revision A (March 2014) to Revision B (April 2016)</b>	<b>Page</b>
• データシートのタイトルを変更.....	1
• データシートに VSSOP (DGS) パッケージを追加.....	1
• 「概要」の文章を明確化のため修正.....	1
• Moved storage temperature from Handling Ratings table to Absolute Maximum Ratings table.....	4
• Changed Handling Ratings to ESD Ratings.....	4
• Added DGS data to <i>Thermal Information</i> table .....	4

---

<b>Changes from Revision * (February 2014) to Revision A (March 2014)</b>	<b>Page</b>
• 製品プレビューのデータシートを変更.....	1

## 5 Pin Configuration and Functions



图 5-1. DSQ Package 10-Pin WSON Top View



图 5-2. DGS Package 10-Pin VSSOP Top View

表 5-1. Pin Functions

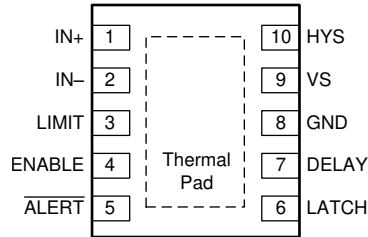
PIN		I/O	DESCRIPTION
NO.	NAME		
1	IN+	Analog input	Connect to supply side of shunt resistor.
2	IN-	Analog input	Connect to load side of shunt resistor.
3	LIMIT	Analog input	Alert threshold limit input. See <a href="#">Setting The Current-Limit Threshold</a> for details on setting limit threshold.
4	ENABLE	Digital input	Enable or disable selection input
5	ALERT	Digital output	Overlimit alert, active-low, open-drain output.
6	LATCH	Digital input	Transparent or latch mode selection input.
7	DELAY	Digital input	Response time selection input.
8	GND	Analog	Ground
9	VS	Analog	Power supply, 2.7 V to 5.5 V.
10	HYS	Digital input	Hysteresis setting input. See <a href="#">Selectable Hysteresis</a> for hysteresis settings.
	Thermal pad	—	This pad can be connected to ground or left floating.

## 6 Specifications

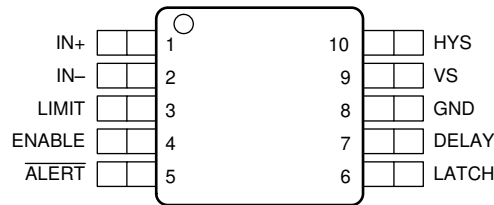
### 6.1 Absolute Maximum Ratings<sup>(1)</sup>

over operating free-air temperature range (unless otherwise noted)

		MIN	MAX	UNIT
Supply voltage, $V_S$			6	V
Analog inputs (IN+, IN-)	Differential ( $V_{IN+} - V_{IN-}$ ) <sup>(2)</sup>	-40	40	V
	Common-mode <sup>(3)</sup>	GND - 0.3	40	
Analog input	LIMIT	GND - 0.3	$(V_S) + 0.3$	V
Digital inputs	LATCH, DELAY, ENABLE, HYS	GND - 0.3	$(V_S) + 0.3$	V
Alert output		GND - 0.3	6	V
Operating temperature		-40	125	°C
Junction temperature, $T_J$			150	°C
Storage temperature, $T_{stg}$		-65	150	°C

- (1) Stresses beyond those listed under *Absolute Maximum Ratings* may cause permanent damage to the device. These are stress ratings only, and do not imply functional operation of the device at these or any other conditions beyond those indicated under *Recommended Operating Conditions*. Exposure to absolute-maximum-rated conditions for extended periods may affect device reliability.
- (2)  $V_{IN+}$  and  $V_{IN-}$  are the voltages at the IN+ and IN- terminals, respectively.
- (3) Input voltage may exceed the voltage shown if the current at that terminal is limited to 5 mA.

### 6.2 ESD Ratings

			VALUE	UNIT
$V_{(ESD)}$	Electrostatic discharge	Human-body model (HBM), per ANSI/ESDA/JEDEC JS-001 <sup>(1)</sup>	±2500	V
		Charged-device model (CDM), per JEDEC specification JESD22-C101 <sup>(2)</sup>	±1000	

- (1) JEDEC document JEP155 states that 500-V HBM allows safe manufacturing with a standard ESD control process.
- (2) JEDEC document JEP157 states that 250-V CDM allows safe manufacturing with a standard ESD control process.

### 6.3 Recommended Operating Conditions

over operating free-air temperature range (unless otherwise noted)

		MIN	NOM	MAX	UNIT
$V_{CM}$	Common-mode input voltage		12		V
$V_S$	Operating supply voltage	2.7	3.3	5.5	V
	Delay setting		100		µs
$T_A$	Operating free-air temperature	-40		125	°C

### 6.4 Thermal Information

THERMAL METRIC <sup>(1)</sup>		INA300		UNIT
		DSQ (WSON)	DGS (VSSOP)	
		10 PINS	10 PINS	
$R_{\theta JA}$	Junction-to-ambient thermal resistance	63.5	169.4	°C/W
$R_{\theta JC(top)}$	Junction-to-case (top) thermal resistance	79.5	59.1	°C/W
$R_{\theta JB}$	Junction-to-board thermal resistance	33.9	89.6	°C/W
$\Psi_{JT}$	Junction-to-top characterization parameter	7.8	8.5	°C/W
$\Psi_{JB}$	Junction-to-board characterization parameter	34.3	88.3	°C/W
$R_{\theta JC(bot)}$	Junction-to-case (bottom) thermal resistance	7.5	n/a	°C/W

- (1) For more information about traditional and new thermal metrics, see the *IC Package Thermal Metrics* application report, [SPRA953](#).

## 6.5 Electrical Characteristics

at  $T_A = 25^\circ\text{C}$ ,  $V_{\text{SENSE}} = V_{\text{IN}+} - V_{\text{IN}-} = 0\text{ mV}$ ,  $V_S = 3.3\text{ V}$ ,  $V_{\text{IN}+} = 12\text{ V}$ ,  $V_{\text{LIMIT}} = 10\text{ mV}$ , and  $\text{DELAY} = 100\text{ }\mu\text{s}$  (unless otherwise noted)

PARAMETER		CONDITIONS	MIN	TYP	MAX	UNIT
<b>INPUT</b>						
$V_{\text{CM}}$	Common-mode input voltage		0		36	V
$V_{\text{IN}}$	Differential input voltage	$V_{\text{IN}} = V_{\text{IN}+} - V_{\text{IN}-}$	0		250	mV
CMR	Common-mode rejection	$V_{\text{IN}+} = 0\text{ V to }36\text{ V}$ , $T_A = -40^\circ\text{C to }125^\circ\text{C}$	100	120		dB
$V_{\text{OS}}$	Offset voltage, RTI <sup>(1)</sup>	$V_S = 3.3\text{ V}$ , DELAY = 100 $\mu\text{s}$		-75	-500	$\mu\text{V}$
		$V_S = +3.3\text{ V}$ , DELAY = 50 $\mu\text{s}$		-125	-500	
		$V_S = +3.3\text{ V}$ , DELAY = 10 $\mu\text{s}$ <sup>(2)</sup>		-350	-650	
$dV_{\text{OS}}/dT$	Offset voltage drift, RTI <sup>(1)</sup>	$T_A = -40^\circ\text{C to }125^\circ\text{C}$		0.1	0.5	$\mu\text{V}/^\circ\text{C}$
PSR	Power-supply rejection ratio	$V_S = 2.7\text{ V to }5.5\text{ V}$ , $V_{\text{IN}+} = 12\text{ V}$ , $T_A = -40^\circ\text{C to }125^\circ\text{C}$		75	150	$\mu\text{V}/\text{V}$
$I_{\text{B}}$	Input bias current			5	10	$\mu\text{A}$
		Disable mode		0.05	0.5	
$I_{\text{OS}}$	Input offset current			$\pm 0.1$		$\mu\text{A}$
$I_{\text{LIMIT}}$	Limit threshold output current	$T_A = 25^\circ\text{C}$	19.9	20	20.1	$\mu\text{A}$
		$T_A = -40^\circ\text{C to }125^\circ\text{C}$	19.85		20.15	
<b>DIGITAL INPUT/OUTPUT</b>						
$t_{\text{p}}$	Alert propagation delay	Delay = open, overdrive = 1 mV		10		$\mu\text{s}$
		Delay = GND, overdrive = 1 mV		50		
		Delay = $V_S$ , overdrive = 1 mV		100		
HYS	Hysteresis	HYS = open		2		mV
		HYS = GND		4		
		HYS = $V_S$		8		
$V_{\text{IH}}$	High-level input voltage	Latch, enable	1.4		6	V
		Delay, hysteresis	$V_S - 0.5$		6	
$V_{\text{IL}}$	Low-level input voltage	Latch, enable	0		0.4	V
		Delay, hysteresis	0		0.5	
$V_{\text{OL}}$	Alert low-level output voltage	$I_{\text{OL}} = 3\text{ mA}$		50	400	mV
	ALERT terminal leakage input current	$V_{\text{OH}} = 3.3\text{ V}$		0.1	1	$\mu\text{A}$
	Digital leakage input current	$0 \leq V_{\text{IN}} \leq V_S$		1	2	$\mu\text{A}$
<b>POWER SUPPLY</b>						
$I_{\text{Q}}$	Quiescent current	$V_{\text{SENSE}} = 0\text{ mV}$ , $T_A = 25^\circ\text{C}$		115	135	$\mu\text{A}$
		$T_A = -40^\circ\text{C to }125^\circ\text{C}$			150	
		$V_{\text{SENSE}} = 0\text{ mV}$ , disable mode, HYS = 2 mV		2	3.5	

(1) RTI = referred-to-input.

(2) Absolute-maximum values are tested with the threshold limit set using the corresponding noise adjustment factor (NAF) value. See [Figure 7.3.7](#) for additional information on applying the NAF value.

## 6.6 Timing Requirements

		MIN	NOM	MAX	UNIT
	Start-up time		1		ms
$t_{\text{en}}$	Enable time		300		$\mu\text{s}$
$t_{\text{dis}}$	Disable time		20		$\mu\text{s}$

### 6.7 Typical Characteristics

at  $T_A = 25^\circ\text{C}$ ,  $V_S = 3.3\text{ V}$ ,  $V_{IN+} = 12\text{ V}$ , alert pull-up resistor =  $10\text{ k}\Omega$ , and Delay =  $100\ \mu\text{s}$  (unless otherwise noted)

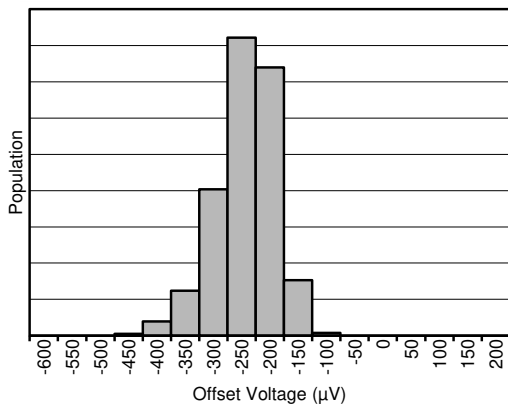

Delay =  $10\ \mu\text{s}$

**6-1. Input Offset Voltage**

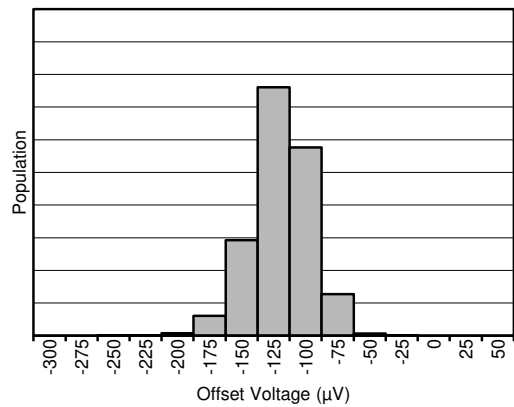

Delay =  $50\ \mu\text{s}$

**6-2. Input Offset Voltage**

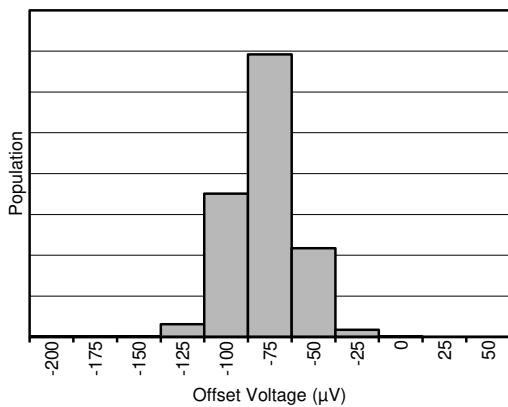

Delay =  $100\ \mu\text{s}$

**6-3. Input Offset Voltage**

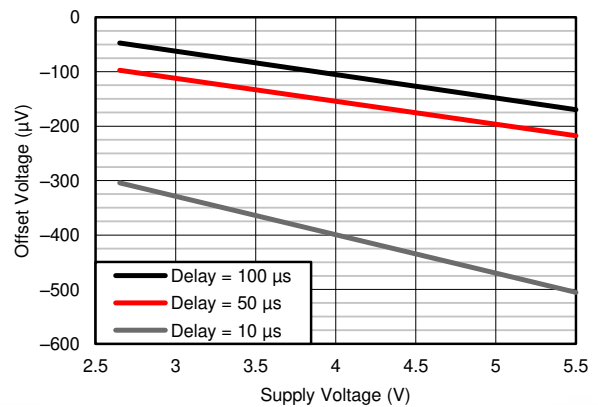

**6-4. Input Offset Voltage vs Supply Voltage**

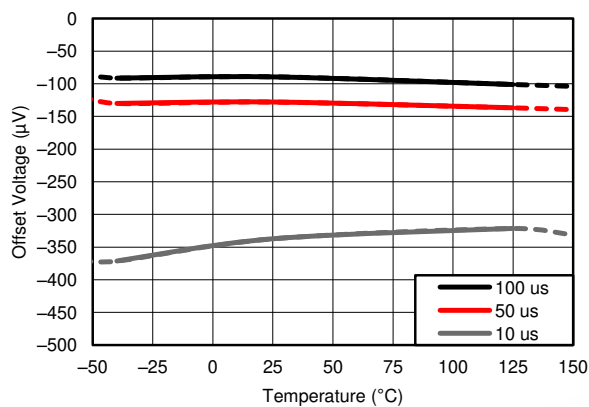

**6-5. Input Offset Voltage vs Temperature**

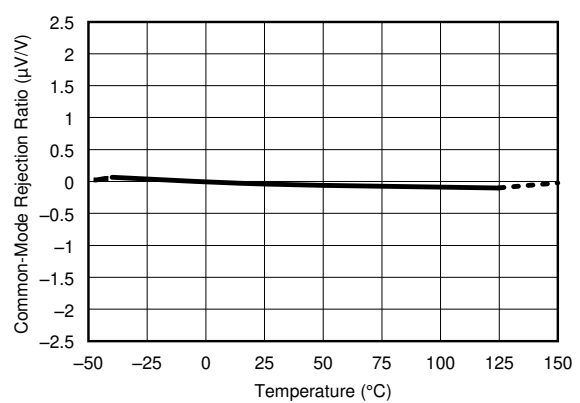

**6-6. Common-Mode Rejection Ratio vs Temperature**

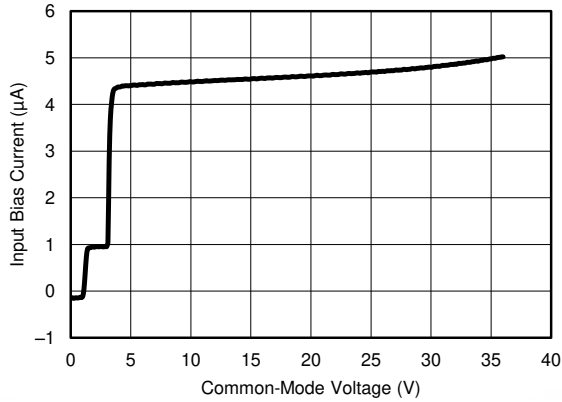

6-7. Input Bias Current vs Common-Mode Voltage (Enabled)

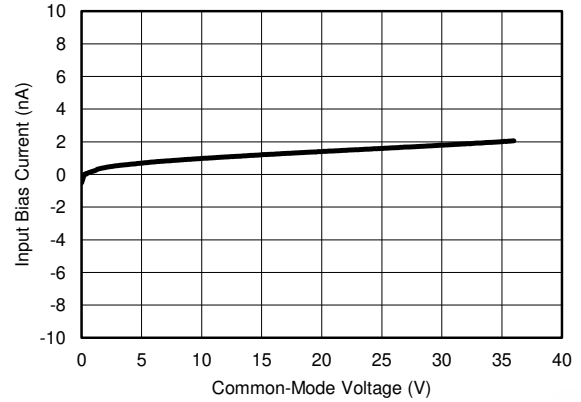

6-8. Input Bias Current vs Common-Mode Voltage (Disabled)

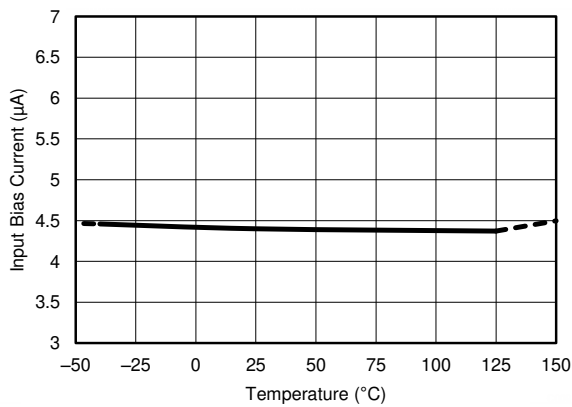

6-9. Input Bias Current vs Temperature (Enabled)

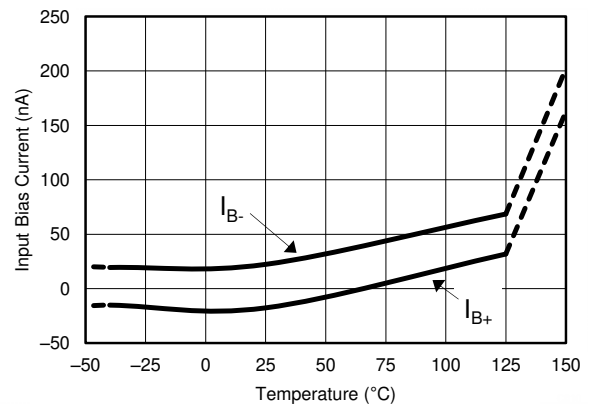

6-10. Input Bias Current vs Temperature (Disabled)

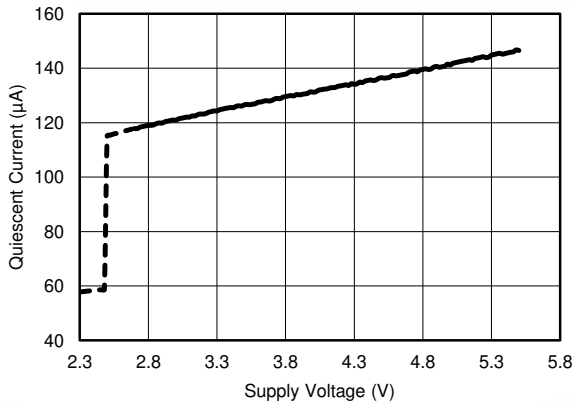

6-11. Quiescent Current vs Supply Voltage (Enabled)

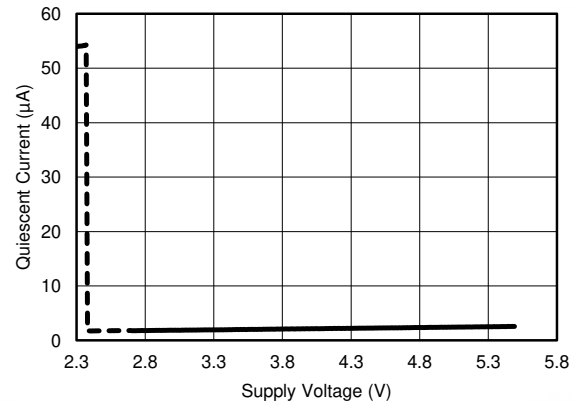

6-12. Quiescent Current vs Supply Voltage (Disabled)

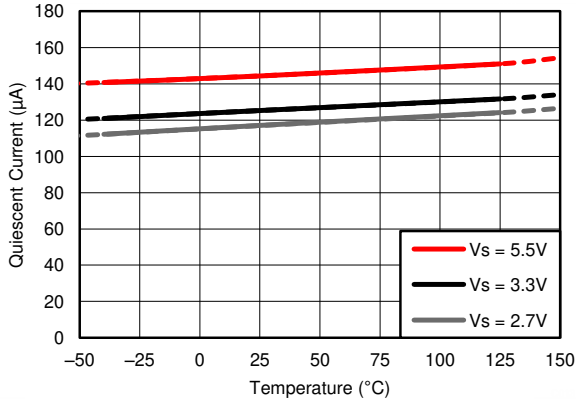

**6-13. Quiescent Current vs Temperature (Enabled)**

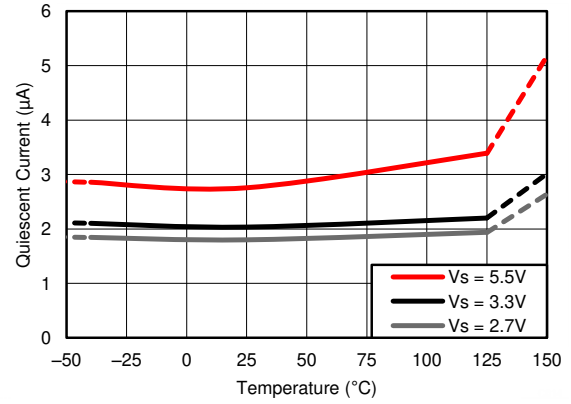

**6-14. Quiescent Current vs Temperature (Disabled)**

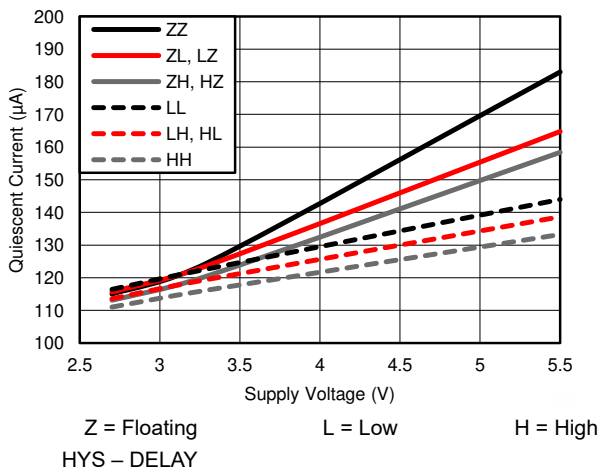

**6-15. Quiescent Current vs HYS and DELAY Settings (Enabled)**

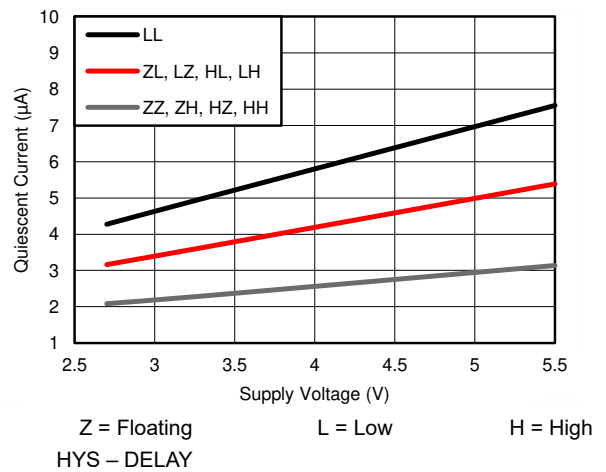

**6-16. Quiescent Current vs HYS and DELAY Settings (Disabled)**

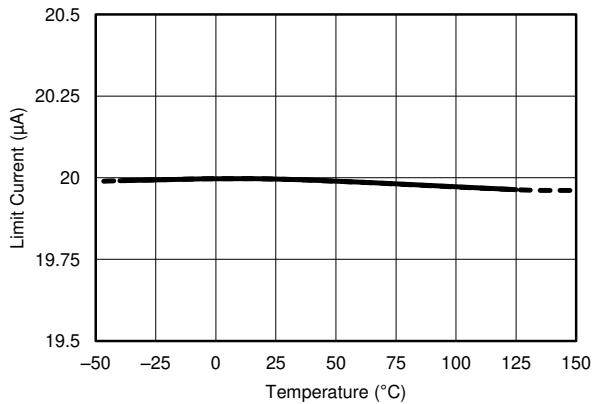

**6-17. Limit Current Source vs Temperature**

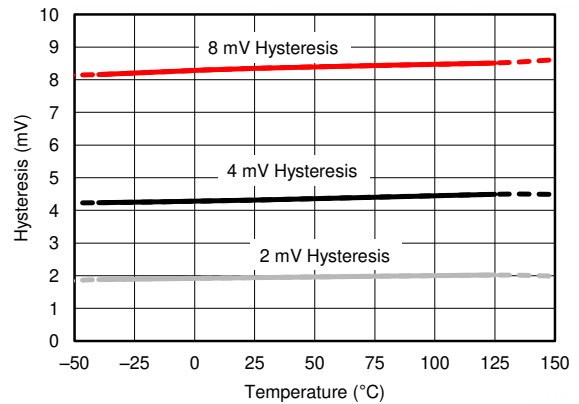

**6-18. Hysteresis vs Temperature**



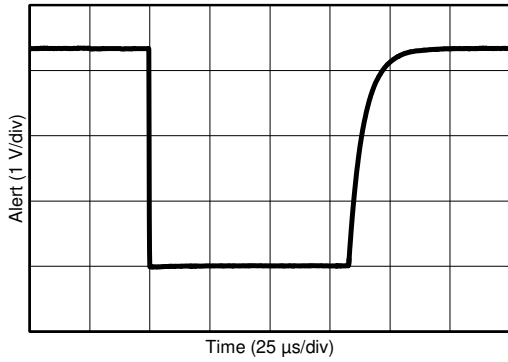

**6-19. Alert Step Response**

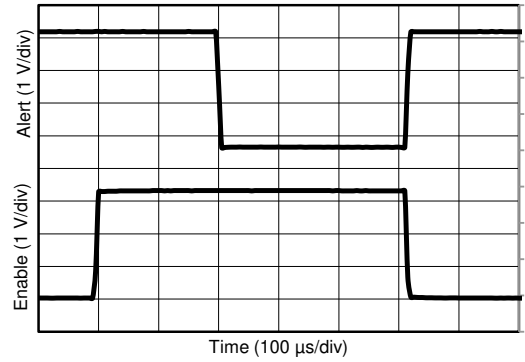

**6-20. Alert Response (Disable to Enable)**

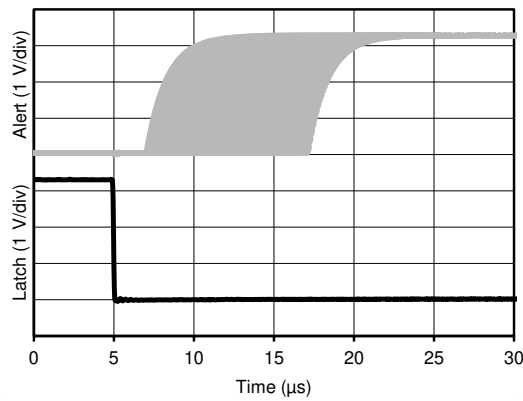

**6-21. Alert Response (Latch Mode to Transparent Mode)**

## 7 Detailed Description

### 7.1 Overview

The INA300 INA300 is a 36-V, common-mode comparator designed for overcurrent protection applications. To reduce the system component count, this device combines the current-sense amplifier and threshold comparison into a single product for the overcurrent detection function. Programming this comparison threshold is configured through a single external resistor, which simplifies the current design while allowing for easy adjustments to the threshold when needed. The threshold setting resistor value is selected based on an internal 20- $\mu$ A current source to achieve a corresponding signal to the voltage that develops across the current-sensing or current-shunt resistor in series with the monitored load current.

The device is designed to accommodate a range of application requirements, including common-mode voltage, noise thresholds, and signal ranges. A wide signal threshold range reaching up to 250 mV is available to accommodate both power-sensitive applications requiring small dissipations across a current sense resistor and larger current-sensing resistors used in lower current applications.

Additional features available with the INA300 INA300 device include a disable mode for reducing the current consumption of the device to below 10  $\mu$ A, an output mode selector to enable a latched or transparent alert output, and a selectable hysteresis value and alert response delay.

The wide signal range of the device is further enhanced with an adjustable hysteresis value to adjust the characteristics of the comparator, which allows for better accommodation of the full input range. The selectable alert response delays present in the INA300 INA300 device assist in optimizing device operation to account for the system noise levels and operating characteristics required from this device. Longer delay settings allow for added rejection of system noise, thus reducing the potential for false alerts resulting from noise spikes that can occur in high-speed comparators.

### 7.2 Functional Block Diagram

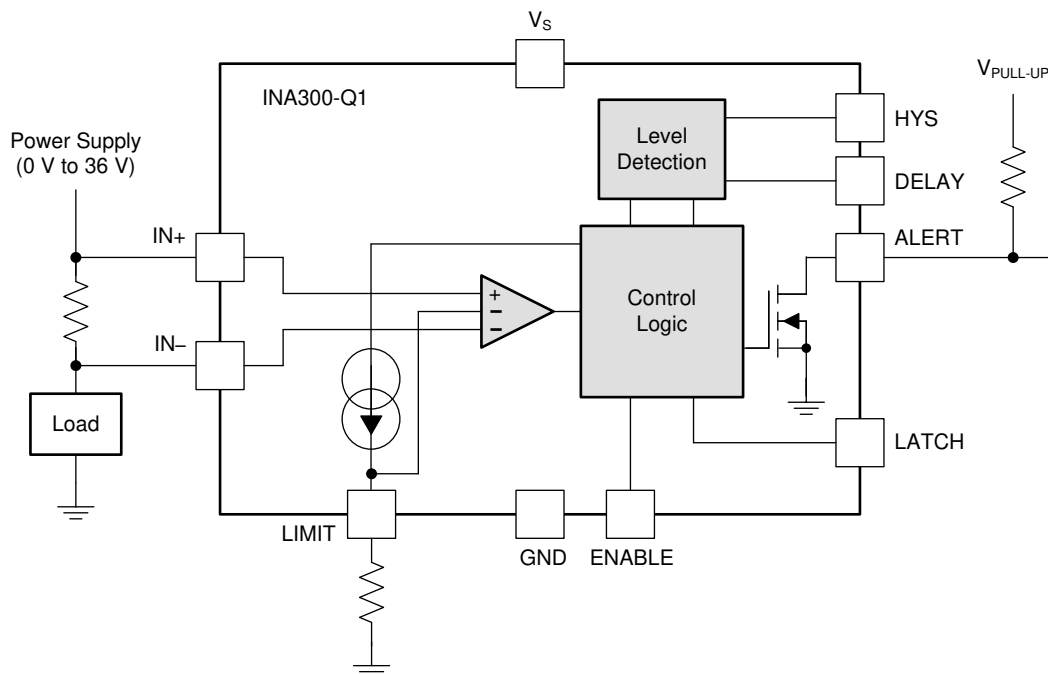

Copyright © 2016, Texas Instruments Incorporated

### 7.3 Feature Description

#### 7.3.1 Selecting a Current-Sensing Resistor

The device measures the differential voltage developed across a resistor when current flows through it to determine if the monitored current exceeds a defined limit. This resistor is referred to as a *current-sensing*

*resistor* or a *current-shunt resistor*, with each term used interchangeably. The flexible design of the device allows for measuring a wide differential input signal range across this current-sensing resistor, which can extend up to 250 mV.

Selecting the value of this current-sensing resistor is based primarily on two factors: the required accuracy of the current measurement and the allowable power dissipation across the current-sensing resistor. Larger voltages developed across this resistor allow more accurate measurements. This large signal accuracy improvement results from the fixed internal amplifier errors that are dominated by the inherent input offset voltage of the device. When the input signal decreases, these fixed internal amplifier errors become a larger portion of the measurement and increase the uncertainty in the measurement accuracy. When the input signal increases, the measurement uncertainty is reduced because the fixed errors are a smaller percentage of measured signal.

A system design trade-off for improving the measurement accuracy using larger input signals is the increase in power across the current-sensing resistor. Increasing the value of the current-shunt resistor increases the differential voltage developed across the resistor when current passes through the component. This increase in voltage across the resistor increases the power that the resistor must be able to dissipate. Decreasing the value of the current-shunt resistor value reduces the power dissipation requirements of the resistor, but increases the measurement errors resulting from the decreased input signal. Selecting the optimal value for the shunt resistor requires factoring both the accuracy requirement for the specific application and the allowable power dissipation of this component.

An increasing number of low ohmic-value resistors are becoming available with values as low as 200  $\mu\Omega$ , with power dissipations of up to 5 W that enable large currents to be monitored with sensing resistors.

#### **7.3.1.1 Selecting a Current-Sensing Resistor: Example**

In this example, the trade-offs involved in selecting a current-sensing resistor are discussed. This example requires a 5% measurement accuracy for detecting a 10-A overcurrent event at a 50- $\mu$ s delay setting where only 250 mW is allowable for the dissipation across the current-sensing resistor at the full-scale current level. Although the maximum power dissipation is defined as 250 mW, a lower dissipation is preferred to improve system efficiency. Some initial assumptions are made that are used in this example: the limit setting resistor,  $R_{LIMIT}$ , is a 1% component and the maximum tolerance specification for the internal threshold setting current source, 0.5%, is used. Given the total error budget of 5%, up to 3.5% of error is available to be attributed to the internal offset of the device.

As shown in 表 7-1, the maximum value calculated for the current-sensing resistor with these requirements is 2.5 mΩ. Although this value satisfies the maximum power dissipation requirement of 250 mW, headroom is available from the 5% maximum total error to reduce the value of the current-sensing resistor and reduce the power dissipation further. Selecting a 1.5-mΩ, current-sensing resistor value offers a tradeoff for reducing the power dissipation in this scenario by approximately 40%, while still remaining within the defined accuracy region.

**表 7-1. Calculating the Current-Sensing Resistor, R<sub>SENSE</sub>**

PARAMETER	EQUATION	VALUE	UNIT
	Maximum measurement error	5%	
I <sub>MAX</sub>	Maximum current	10	A
P <sub>RSENSE</sub>	Maximum allowable R <sub>SENSE</sub> power dissipation	$R_{SENSE} \times I_{MAX}^2$	mW
	Initial error	R <sub>LIMIT</sub> + I <sub>LIMIT</sub> tolerances	1.5%
R <sub>SENSE_MAX</sub>	Maximum sensing resistor value	$P_{RSENSE} / I_{MAX}^2$	mΩ
V <sub>SENSE_MAX</sub>	Input sense voltage	$R_{SENSE\_MAX} \times I_{MAX}$	mV
V <sub>OS_Error</sub>	Offset voltage error	$(V_{OS} / V_{SENSE\_MAX}) \times 100$	2%
Error_Available	Maximum allowable offset error	Maximum Error – Initial Error	3.5%
V <sub>SENSE_MIN</sub>	Minimum input sense voltage	$V_{OS} / (Error\_Available / 100)$	mV
R <sub>SENSE_MIN</sub>	Minimum sensing resistor value	$V_{SENSE\_MIN} / I_{MAX}$	mΩ
P <sub>RSENSE_MIN</sub>	Minimum power dissipation	$R_{SENSE\_MIN} \times I_{MAX}^2$	mW

### 7.3.2 Setting The Current-Limit Threshold

The device determines if an overcurrent event is present by comparing the measured differential voltage developed across the current-sensing resistor to the corresponding signal programmed at the LIMIT terminal. The threshold voltage for the LIMIT terminal can be set using a resistor or an external voltage source.

#### 7.3.2.1 Resistor-Controlled Current Limit

The typical approach for setting the limit threshold voltage is to connect a resistor from the LIMIT terminal to ground. The value of this resistor, R<sub>LIMIT</sub>, is chosen to create a corresponding voltage at the LIMIT terminal equivalent to the voltage, V<sub>TRIP</sub>, developed by the load current flowing through the current-sensing resistor. An internal 20-μA current source is present at the LIMIT terminal that creates the corresponding voltage depending on the value of R<sub>LIMIT</sub>. In the equations from 表 7-2, V<sub>TRIP</sub> represents the overcurrent threshold the device is programmed to monitor for and V<sub>LIMIT</sub> is the programmed signal set to detect the V<sub>TRIP</sub> level. The term *noise adjustment factor* (NAF) is included in the V<sub>LIMIT</sub> equation for the 10-μs delay setting. This value is equal to 500 μV and adjusts the operating point for the internal noise in this delay setting. The 50-μs and 100-μs delay settings do not use the NAF term in calculating the V<sub>LIMIT</sub> threshold. See [Noise Adjustment Factor \(NAF\)](#) for more details on the noise adjustment factor.

In 表 7-2, the process for calculating the required value for R<sub>LIMIT</sub> to set the appropriate threshold voltage, V<sub>LIMIT</sub>, is shown. This calculation is based on the 10-μs delay setting so the NAF term is included in the calculation. For a delay setting of 50 μs or 100 μs, the NAF term is omitted.

**表 7-2. Calculating the Limit Threshold Setting Resistor, R<sub>LIMIT</sub>**

PARAMETER	EQUATION
V <sub>TRIP</sub>	Desired current trip value
	$I_{LOAD} \times R_{SENSE}$
V <sub>LIMIT</sub>	Programmed threshold limit voltage
	$V_{LIMIT} = V_{TRIP}$
V <sub>LIMIT</sub> <sup>(1)</sup>	Threshold voltage
	$(I_{LIMIT} \times R_{LIMIT}) - NAF$
R <sub>LIMIT</sub> <sup>(1)</sup>	Threshold limit setting resistor
	$(V_{LIMIT} + NAF) / I_{LIMIT}$
R <sub>LIMIT</sub> <sup>(1)</sup>	Limit setting resistor
	$(V_{LIMIT} + 500 \mu V) / 20 \mu A$

(1) NAF is used with the 10-μs delay setting. NAF can be omitted in the R<sub>LIMIT</sub> calculation for the 50-μs and 100-μs delay settings.

TI recommends using NAF in calculating the value for V<sub>LIMIT</sub> and R<sub>LIMIT</sub> at the 10-μs delay setting. Removing NAF from the V<sub>LIMIT</sub> and R<sub>LIMIT</sub> calculation at the 10-μs delay setting lowers the trigger point of the alert output.

Lowering the trigger point results in the device issuing an overcurrent alert prior to reaching the corresponding  $V_{TRIP}$  threshold. The averaging effect included with the 50- $\mu$ s and 100- $\mu$ s delay settings inherently eliminates the effect internal noise has on the threshold voltage.

### 7.3.2.2 Voltage Source-Controlled Current Limit

The second method for setting the limit voltage is to connect the LIMIT terminal to a programmable DAC (digital-to-analog converter) or other external voltage source. The benefit of this method is the ability to adjust the current limit to account for different threshold voltages that are used for different system operating conditions. For example, this method can be used in a system that has one current-limit threshold level that must be monitored during the power-up sequence but different thresholds must be monitored during other system operating modes.

In 表 7-3,  $V_{TRIP}$  represents the overcurrent threshold the device is programmed to monitor for and  $V_{SOURCE}$  is the programmed signal set to detect the  $V_{TRIP}$  level. NAF is included in the  $V_{SOURCE}$  equation for the 10- $\mu$ s delay setting. This value equals 500  $\mu$ V and is adjusts the operating point for the noise in the delay setting. The 50- $\mu$ s and 100- $\mu$ s delay settings do not use the NAF term in calculating the  $V_{SOURCE}$  threshold. For these delay settings, the NAF term is omitted. See the [Noise Adjustment Factor \(NAF\)](#) section for more details on the noise adjustment factor.

**表 7-3. Calculating the Limit Threshold Voltage Source,  $V_{SOURCE}$**

PARAMETER		EQUATION
$V_{TRIP}$	Desired current trip value	$I_{LOAD} \times R_{SENSE}$
$V_{SOURCE}^{(1)}$	Programmed threshold limit voltage	$V_{TRIP} + NAF$
$V_{SOURCE}^{(1)}$	Programmed signal set to detect the $V_{TRIP}$ level	$V_{TRIP} + 500 \mu V$

(1) NAF is used with the 10- $\mu$ s delay setting. NAF can be omitted in the  $V_{SOURCE}$  calculation for the 50- $\mu$ s and 100- $\mu$ s delay settings.

TI recommends using NAF in calculating the value for  $V_{SOURCE}$  at the 10- $\mu$ s delay setting. Removing NAF from the  $V_{SOURCE}$  calculation at the 10- $\mu$ s delay setting lowers the trigger point of the alert output. Lowering the trigger point results in the device issuing an overcurrent alert prior to reaching the corresponding  $V_{TRIP}$  threshold. The averaging effect included with the 50- $\mu$ s and 100- $\mu$ s delay settings inherently eliminates the effect internal noise has on the threshold voltage.

### 7.3.3 Delay Setting

The device response time for overcurrent events is adjustable based on the DELAY terminal setting. Three response time settings are available, ranging from 10  $\mu$ s to 100  $\mu$ s. The primary purpose for the three different delay settings is to offer a trade-off between a faster alert response and a more precise overcurrent threshold level detection.

The device has a 10- $\mu$ s internal comparison window. This single comparison window is the fundamental time unit used for all three delay settings. For the 10- $\mu$ s delay setting, the device compares the average of the input signal during the 10- $\mu$ s comparison window to the threshold limit programmed at the LIMIT terminal. If the averaged input signal exceeds the threshold at the end of the 10- $\mu$ s comparison window, the output alert triggers and pulls the ALERT terminal low. However, if the averaged input does not exceed the threshold at the end of the 10- $\mu$ s comparison window, there is no change in the output alert status, which remains high to indicate that no overcurrent event is detected.

For the 50- $\mu$ s delay setting, there must be five consecutive 10- $\mu$ s comparison windows that result in an average input signal exceeding the threshold limit in order for the output alert to trigger and pull the ALERT terminal low. If any single 10- $\mu$ s comparison window fails to detect an overcurrent condition before reaching five consecutive overcurrent comparisons, the internal counter is reset and no output alert is issued. With the internal counter reset, a new group of five consecutive 10- $\mu$ s comparison windows of overcurrent conditions are required in order to trigger the alert and pull the ALERT terminal low.

The 100- $\mu$ s delay setting operates in the same manner as the 50- $\mu$ s method, but instead requires ten consecutive 10- $\mu$ s comparison windows with an input signal exceeding the threshold limit to issue an output alert and pull the ALERT terminal low.

Requiring multiple consecutive overcurrent detections aids significantly in reducing the likelihood of system noise causing false alerts, which can be detrimental to critical system operations. However, by enabling an alert window equal to the comparison window of 10  $\mu\text{s}$ , the device still has the flexibility to be used in fast overcurrent detection applications that require quick responses to rapidly changing system operating characteristics.

In  7-1, the device alert output response is shown for a 10- $\mu\text{s}$  delay setting and a 50- $\mu\text{s}$  delay setting based on the same input signal condition. The initial increase of the input signal,  $V_{\text{IN}}$ , above the  $V_{\text{LIMIT}}$  level remains above the limit for approximately 30  $\mu\text{s}$ . With the device set to the 10- $\mu\text{s}$  delay setting, the overcurrent condition is detected and the alert output terminal is pulled low approximately 10  $\mu\text{s}$  later. With the device set to the 50- $\mu\text{s}$  delay setting, an alert is not issued because five consecutive 10- $\mu\text{s}$  overcurrent measurements are not detected. With the input signal only being over the limit for 30  $\mu\text{s}$  rather than the corresponding 50  $\mu\text{s}$  needed for this delay setting, the device does not issue an alert under this condition. For the second instance where  $V_{\text{IN}}$  rises above the  $V_{\text{LIMIT}}$  threshold, the input remains above the limit for more than five consecutive 10- $\mu\text{s}$  measurements, indicating an overcurrent condition and the alert output terminal is pulled low.

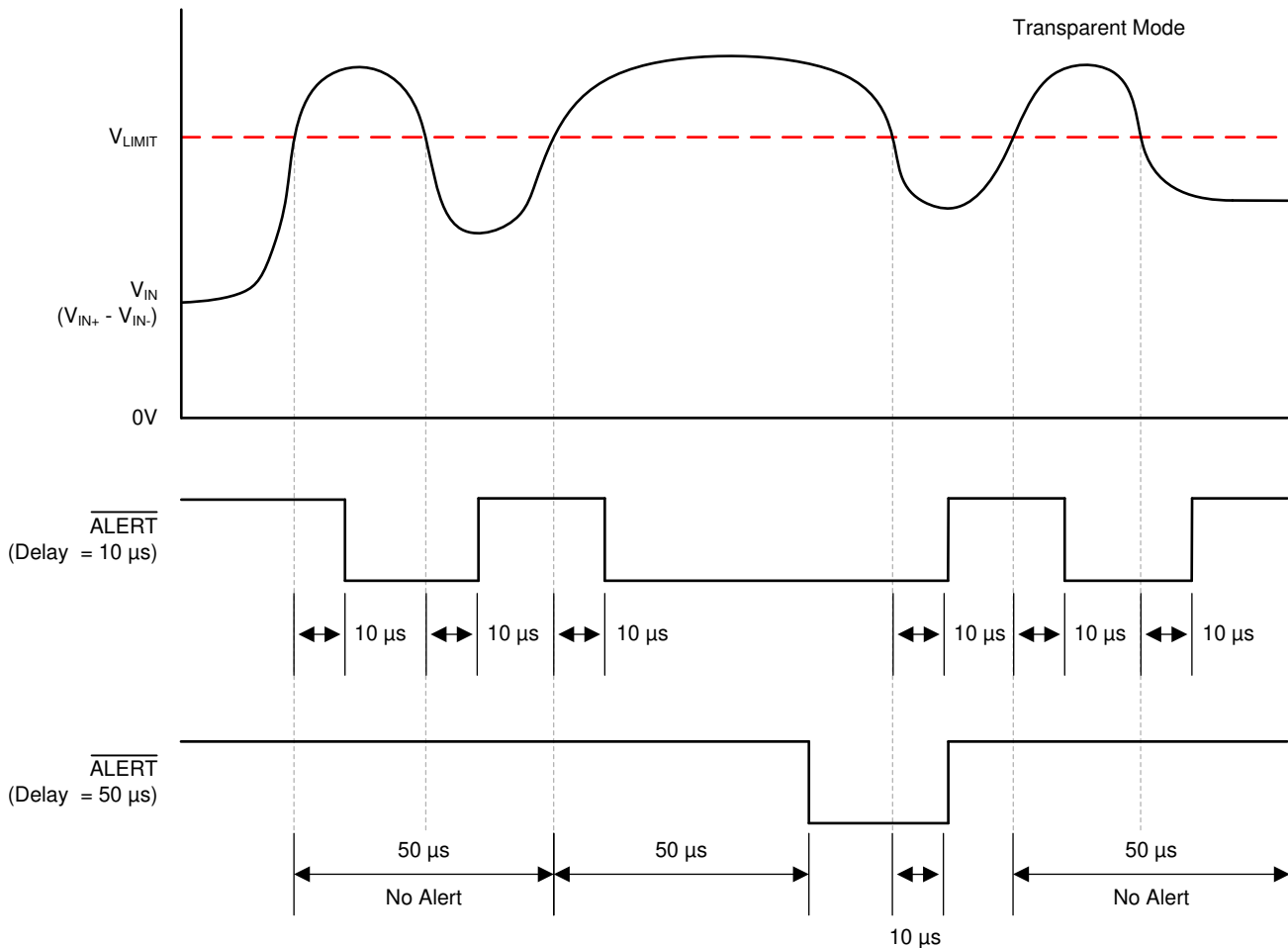

 7-1. DELAY Terminal Settings

As discussed previously, there are three different available delay settings that are configured based on the signal connected to the DELAY terminal, as shown in 图 7-2 and 表 7-4. The DELAY terminal must be either connected directly to ground, directly to supply, or left completely floating. Additional external resistors must not be connected to this terminal. If a resistance is required by the application to be placed in series with either the supply or ground connection to the DELAY terminal, this resistance must be limited to 1 kΩ so as to not conflict with the internal level-detection circuitry.



图 7-2. Delay Response

表 7-4. Delay Settings

DELAY	ALERT DELAY (μs)
Open or floating	10
GND	50
V <sub>S</sub>	100

### 7.3.4 Alert Timing Response

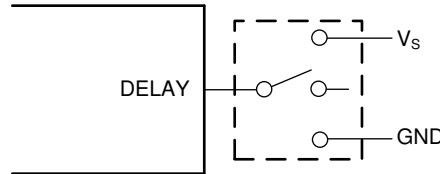
The device has a 10-μs internal comparison window where the input signal is measured to compare to the limit threshold voltage. This window continuously runs internal to the device without any external indicator or control. A comparison is made at the completion of each 10-μs comparison window to determine if the averaged input over the comparison window exceeds the limit threshold, thus indicating if an overcurrent event has occurred.

This comparison window is not synchronized with the input signal so there is an unknown timing component present. With this free-running internal timing window, an overcurrent event can occur anywhere within the 10-μs comparison window. This condition causes a variation in the amount of time before the alert appears at the output because the comparison is always made at the end of the 10-μs comparison window. 图 7-3 shows the variation in time between when the input signal rises above the threshold voltage and when a change at the alert output terminal occurs.



图 7-3. 10-μs Alert Response Window

The delay shown in [Figure 7-3](#) represents the response time of the device with a 10- $\mu$ s delay setting. With a 50- $\mu$ s delay setting, an additional 40  $\mu$ s is added to the timing response, as shown in [Figure 7-4](#). A 100- $\mu$ s delay setting adds 90  $\mu$ s to the response time, as shown in [Figure 7-5](#).

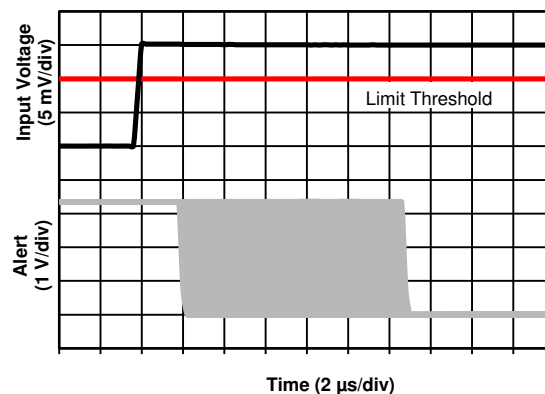
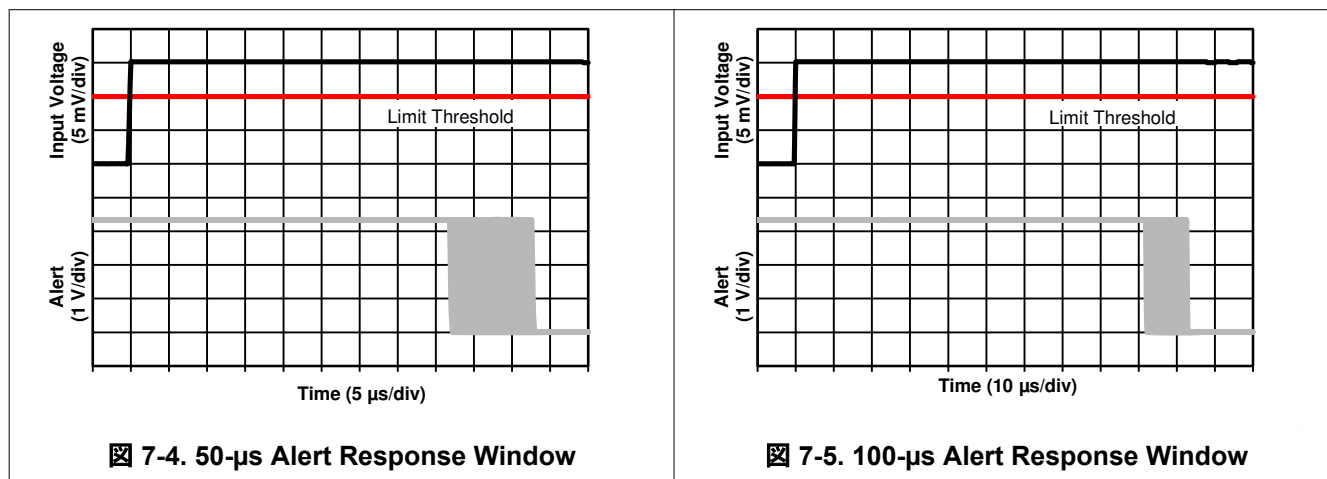

### 7.3.5 Selectable Hysteresis

Device hysteresis is adjustable based on the setting at the hysteresis (HYS) terminal. The smallest setting for hysteresis on the device, 2 mV, is enabled by leaving the HYS terminal open and floating. A 4-mV hysteresis is set by connecting the HYS terminal to ground; connecting this terminal to the supply voltage sets the hysteresis to 8 mV, as shown in [Figure 7-6](#). The HYS terminal must be either connected directly to ground, directly to supply, or left completely floating. Additional external resistors must not be connected to this terminal. If a resistance is required by the application to be placed in series with either the supply or ground connections to the HYS terminal, this resistance must be limited to 1 k $\Omega$  so as to not conflict with the internal level-detection circuitry.

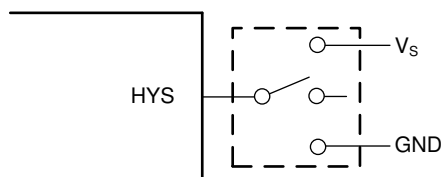

**Figure 7-6. Hysteresis**



The wide dynamic input range of the INA300 necessitates an adjustable hysteresis to ensure that the device can be appropriately configured based on the specific operating conditions and application requirements. Figure 7-7 illustrates the transition locations for the  $\overline{\text{ALERT}}$  terminal based on where the input signal,  $V_{\text{IN}}$ , is measured relative the limit threshold,  $V_{\text{LIMIT}}$ . The corresponding hysteresis levels and physical terminal settings for the device are shown in Table 7-5.

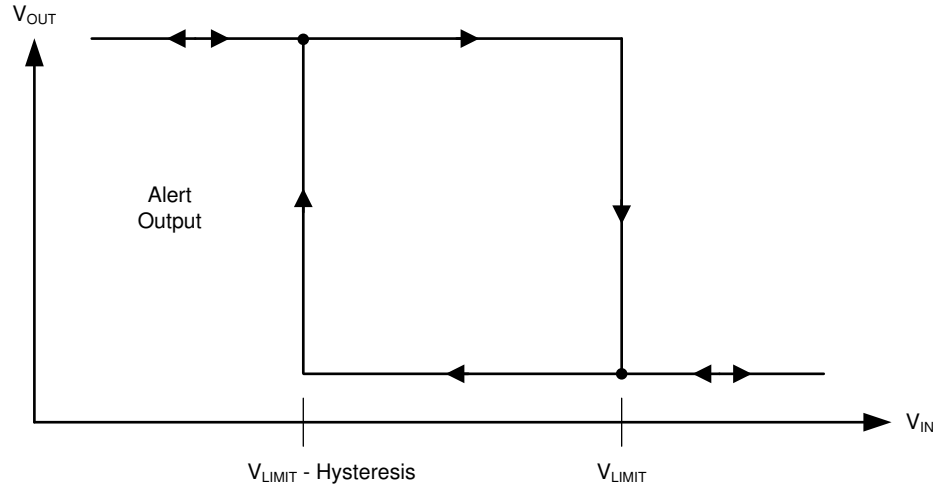

Figure 7-7. Typical Comparator Hysteresis

Table 7-5. Hysteresis Settings

HYSTERESIS	HYSTERESIS SETTING
Float	2 mV
GND	4 mV
$V_{\text{S}}$	8 mV

### 7.3.6 Alert Output

The device  $\overline{\text{ALERT}}$  terminal is an active-low, open-drain output. This output is designed to be pulled low when the input conditions are detected as out-of-range. This open-drain output pin is recommended to include a 10-k $\Omega$ , pull-up resistor to the supply voltage. This open-drain terminal can be pulled up to a voltage beyond the supply voltage,  $V_{\text{S}}$ , but must not exceed 5.5 V.

### 7.3.7 Noise Adjustment Factor (NAF)

The device is a high-speed, low-noise comparator that is designed to alert when the measured input signal exceeds the programmed limit level. Internal noise in the device couples into the measurement and can result in alerts being issued prior to the input signal exceeding the voltage level present at the LIMIT terminal. This known internal noise component effects the input signal measurement by causing a consistent shift in the device internal offset, resulting in a shifted trip threshold. NAF adjusts the  $V_{\text{LIMIT}}$  setting to account for this internal shift, thus allowing for a more precise level detection of the measured current.

The NAF value is based on the noise contribution on the measurement at the 10- $\mu\text{s}$  delay setting. This value is equal to 500  $\mu\text{V}$  and is applied in the calculation to adjust the  $V_{\text{LIMIT}}$  threshold level to allow for a more accurate alert trip point. The NAF term is only applied in the  $V_{\text{LIMIT}}$  calculation at the 10- $\mu\text{s}$  delay setting. The averaging effect included with the 50- $\mu\text{s}$  and 100- $\mu\text{s}$  delay settings inherently eliminates the effect internal noise has on the threshold voltage. The NAF term can be omitted from the  $R_{\text{LIMIT}}$  calculation at the 10- $\mu\text{s}$  delay setting with the effect of a lower trigger point of the alert output. Lowering the trigger point results in an overcurrent alert prior to reaching the corresponding  $V_{\text{TRIP}}$  threshold.

## 7.4 Device Functional Modes

### 7.4.1 Alert Mode

The device has two output operating modes that are selected based on the LATCH terminal setting: transparent mode and latch mode. These modes change how the  $\overline{\text{ALERT}}$  terminal responds to the changing input signal conditions.

#### 7.4.1.1 Transparent Output Mode

The device is set to transparent mode when the LATCH terminal is pulled low, thus allowing the output alert state to change and follow the input signal with respect to the programmed alert threshold. For example, when the differential input signal rises above the alert threshold, the alert output terminal is pulled low. When the differential input signal drops below the alert threshold for 10  $\mu\text{s}$ , the output returns to the default high output state. A common implementation using the device in transparent mode is to connect the  $\overline{\text{ALERT}}$  terminal to a hardware interrupt input on a controller. As soon as an overcurrent condition is detected in the device and the  $\overline{\text{ALERT}}$  terminal is pulled low, the controller interrupt terminal detects the output state change and can begin making changes to the system operation needed to address the overcurrent condition.

#### 7.4.1.2 Latch Output Mode

Some applications do not have the functionality available to continuously monitor the state of the output  $\overline{\text{ALERT}}$  terminal to detect an overcurrent condition. A typical example of this application is a system that is only able to poll the  $\overline{\text{ALERT}}$  terminal state periodically to determine if the system is functioning correctly. If the device is set to transparent mode in this type of application, missing the change in state of the  $\overline{\text{ALERT}}$  terminal is possible when  $\overline{\text{ALERT}}$  is pulled low to indicate an out-of-range event if the out-of-range condition does not appear during one of these periodic polling events.

Latch mode is specifically intended to accommodate these applications. As shown in [表 7-6](#), the device is placed in latch mode by setting the voltage on the LATCH terminal to a logic high level. The difference between latch mode and transparent mode is how the alert output responds when an overcurrent event ends. In transparent mode, when the differential input signal drops below the limit threshold level for 10  $\mu\text{s}$ , the output state returns to the default high setting to indicate that the overcurrent event had ended.

In latch mode, when an overlimit condition is detected and the  $\overline{\text{ALERT}}$  terminal is pulled low, the  $\overline{\text{ALERT}}$  terminal does not return to the default high level when the differential input signal drops below the alert threshold level for 10  $\mu\text{s}$ . To clear the alert the LATCH terminal must be pulled low for at least 20  $\mu\text{s}$ . Pulling the LATCH terminal low allows the  $\overline{\text{ALERT}}$  terminal to return to the default high level, provided that the differential input signal has dropped below the alert threshold. If the input signal is still above the threshold limit when the LATCH terminal is pulled low, the  $\overline{\text{ALERT}}$  terminal remains low. When the alert condition is detected by the system controller (the LATCH terminal) can be set back to high in order to place the device back in latch mode.

**表 7-6. Output Mode Settings**

OUTPUT MODE	LATCH TERMINAL SETTING
Transparent mode	LATCH = low
Latch mode	LATCH = high

The latch and transparent modes are represented in Figure 7-8. In Figure 7-8 when  $V_{IN}$  drops back below the  $V_{LIMIT}$  threshold for the first time, the LATCH terminal is pulled high. With the LATCH terminal pulled high, the device is set to latch mode so that the alert output state does not return high when the input signal drops below the  $V_{LIMIT}$  threshold. Only when the LATCH terminal is pulled low does the  $\overline{ALERT}$  terminal return to the default high level, indicating that the input signal is below the limit threshold. When the input signal drops below the limit threshold for the second time, the LATCH terminal is already pulled low. The device is set to transparent mode at this point and the  $\overline{ALERT}$  terminal is pulled back high when the input signal drops below the alert threshold.

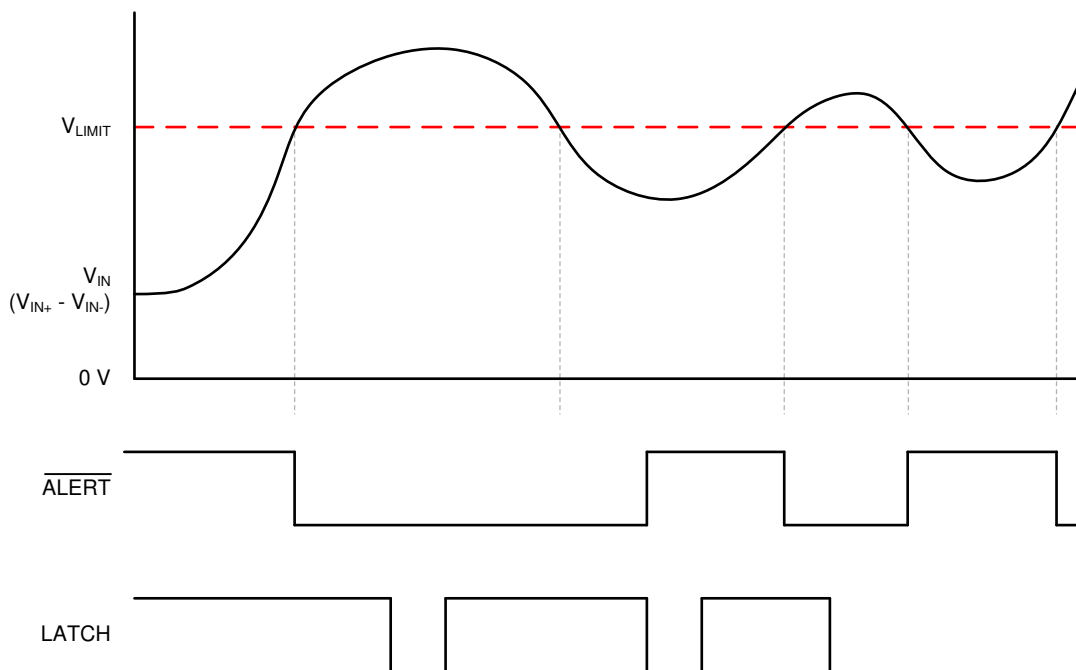

Figure 7-8. Transparent vs Latch Mode

#### 7.4.2 Disable Mode

The INA300 device has an ENABLE terminal that allows the device to be placed into an active enabled state or a low-power disabled state where less than 10  $\mu\text{A}$  is consumed from all terminals. This disable state allows the device to be used in applications where low current consumption is required to extend battery life where constant monitoring is not required. The INA300 device requires approximately 20  $\mu\text{s}$  to enter the low-power state when the ENABLE terminal transitions from high to low, as shown in Figure 7-7. To return to the enabled active state, the INA300 device requires approximately 300  $\mu\text{s}$  to return to normal operation when the ENABLE terminal transitions from low to high, taking the device out of the low-power state.

Table 7-7. Enable and Disable Mode Settings

ENABLE MODE	ENABLE TERMINAL SETTING
Disable mode	ENABLE = low
Enable mode	ENABLE = high

The internal counter that determines if the necessary consecutive 10- $\mu\text{s}$  window comparison alert conditions are reached for the 50- $\mu\text{s}$  and 100- $\mu\text{s}$  delay setting is reset when the device is put into a disabled state. When the device is re-enabled, the counter restarts.

### 7.4.3 Input Filtering

External system noise can have a significant effect in the ability of a comparator to accurately measure and detect whether input signals exceed the reference threshold levels, indicating an overrange condition. The device is susceptible to external noise, although the 50- $\mu$ s and 100- $\mu$ s delay settings are can mitigate the impact of noise based on the effective averaging achieved in these modes. The obvious effect that external noise can have on the operation of a comparator is to cause a false alert condition. If a comparator detects a large noise transient coupled into the signal, the device can interpret this transient as an overrange condition.

External filtering can help reduce the amount of noise that reaches the comparator inputs, and can reduce the likelihood of a false alert from occurring. The tradeoff to adding this noise filter is increased comparator response time, because of the input signal being filtered as well as the noise. [Figure 7-9](#) shows the implementation of an input filter for the device.

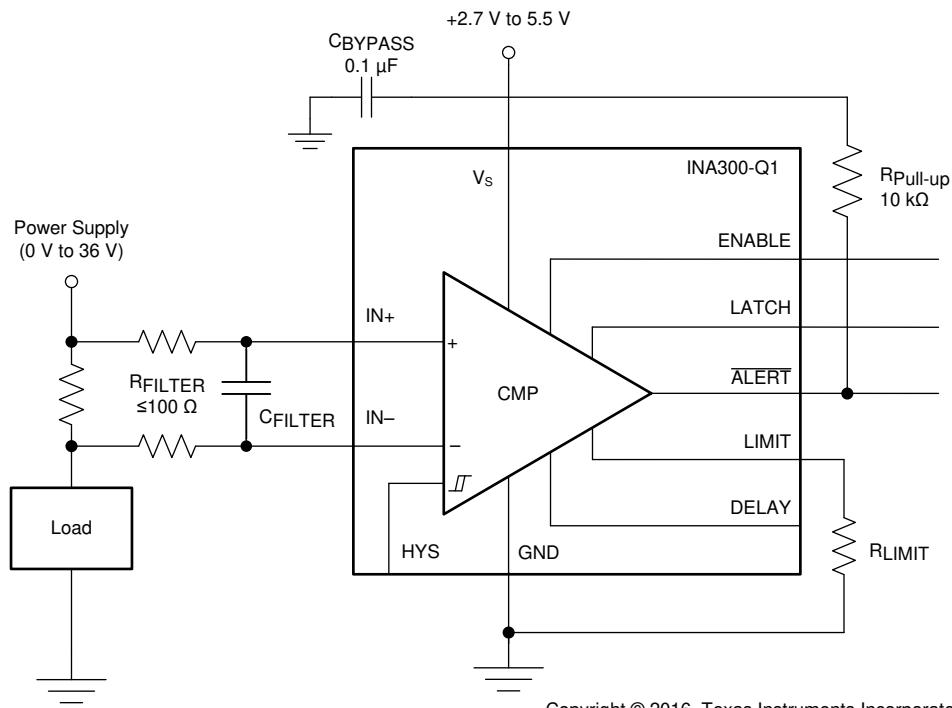

Copyright © 2016, Texas Instruments Incorporated

**Figure 7-9. Input Filter**

Limiting the amount of input resistance used in this filter is important because this resistance can have a significant effect on the input signal that reaches the device input pins resulting from the device input bias currents. A typical system implementation involves placing the current-sensing resistor near the device so the traces are short and the trace impedance is small. This layout helps reduce the ability of coupling additional noise into the measurement. Under these conditions, the characteristics of the input bias currents have minimal effect on device performance.

As shown in [Figure 7-10](#), the input bias currents increase in opposite directions when the differential input voltage increases. This increase results from the design of the device, which allows common-mode input voltages to far exceed the device supply voltage range. With input filter resistors now placed in series with these unequal input bias currents, there are unequal voltage drops developed across the input resistors. The difference between the two drops appears as an added signal that (in this case) subtracts from the voltage developed across the current-sensing resistor, reducing the signal that reaches the device input terminals. Smaller value input resistors reduce this effect of signal attenuation to allow for a more accurate measurement.

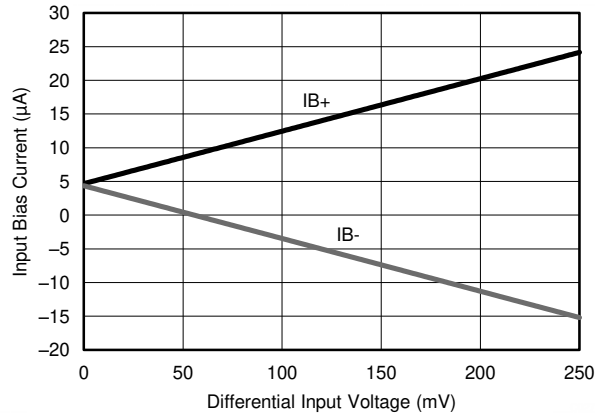

7-10. Input Bias Current vs Differential Input Voltage

For example, with a differential voltage of 10 mV developed across a current-sensing resistor and using 100-Ω resistors, the differential signal that reaches the device is 9.8 mV. A measurement error of 2% is created as a result of the external input filter resistors. Using 10-Ω input filter resistors instead of the 100-Ω resistors reduces this added error from 2% to 0.2%.

#### 7.4.4 Using the INA300 With Common-Mode Transients Above 36 V

With a small amount of additional circuitry, the device can be used in circuits subject to transients higher than 36 V. Use only zener diodes or zener-type transient absorbers (sometimes referred to as *Transzorbs*). Any other type of transient absorber has an unacceptable time delay. Start by adding a pair of resistors, as shown in 7-11, as a working impedance for the zener diode. Keeping these resistors as small as possible is best, preferably 100 Ω or less. Larger values can be used with an additional error induced resulting from a reduced signal that reaches the device input terminals. Because this circuit limits only short-term transients, many applications are satisfied with a 100-Ω resistor along with conventional zener diodes of the lowest power rating available. This combination uses the least amount of board space. These diodes can be found in SOT-523 or SOD-523 packages.

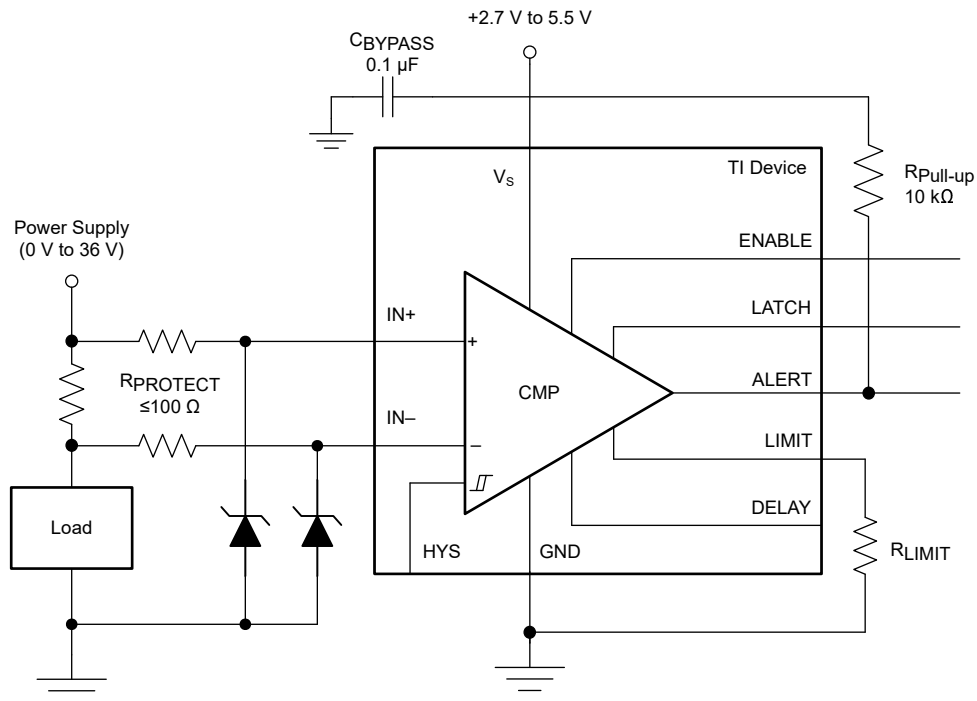

7-11. Transient Protection

## 8 Application and Implementation

### Note

Information in the following applications sections is not part of the TI component specification, and TI does not warrant its accuracy or completeness. TI's customers are responsible for determining suitability of components for their purposes, as well as validating and testing their design implementation to confirm system functionality.

### 8.1 Application Information

The INA300 is designed to enable configuration for detecting overcurrent conditions in an application. This device is individually targeted towards overcurrent detection of a single threshold. However, this device can be paired with additional devices and circuitry to create more complex monitoring functional blocks.

### 8.2 Typical Applications

#### 8.2.1 Unidirectional Operation

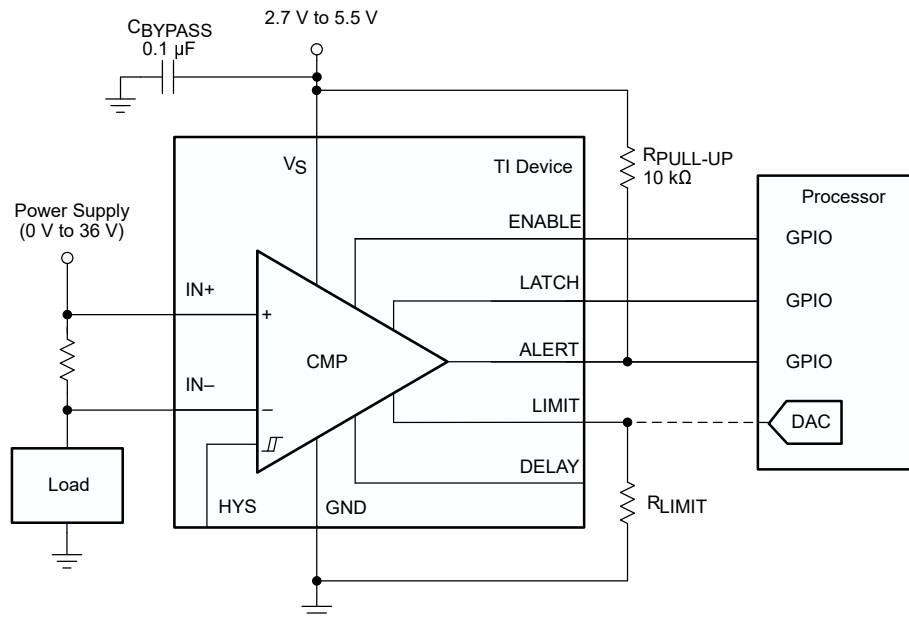

8-1. Unidirectional Application Schematic

##### 8.2.1.1 Design Requirements

The INA300 device measures current through a resistive shunt with current flowing in one direction, enabling detection of an overcurrent event only when the differential input voltage exceeds the threshold limit.

##### 8.2.1.2 Detailed Design Procedure

8-1 shows the basic connections of the INA300 device. The input terminals, IN+ and IN–, must be connected as closely as possible to the current-sensing resistor to minimize any resistance in series with the shunt resistance. Additional resistance between the current-sensing resistor and input terminals can result in errors in the measurement. When input current flows through this external input resistance, the voltage developed across the shunt resistor can differ from the voltage reaching the input terminals.

### 8.2.1.3 Application Curve

Figure 8-2 shows the alert response transitioning from a high to a low state following the input signal exceeding the limit threshold voltage. The time required for the output to respond varies as a result of when the input signal crosses the threshold limit voltage relative to where in the continuous running internal 10- $\mu$ s comparison window the overrange condition occurs. In Figure 8-2, the output response varies from roughly 2  $\mu$ s to approximately 12  $\mu$ s when the input exceeds the threshold level. This variance is a result of where in the 10- $\mu$ s comparison window the overrange event occurs. If the overrange event occurs late in the 10- $\mu$ s comparison window and is large enough to average the entire window measurement up above the threshold level, the alert appears to respond very quickly. If the alert occurs late in the 10- $\mu$ s comparison window and is not large enough to average the entire window measurement up above the threshold level, the alert does not appear until the next 10- $\mu$ s comparison window completes, assuming the input signal remains above the threshold for the entire duration.

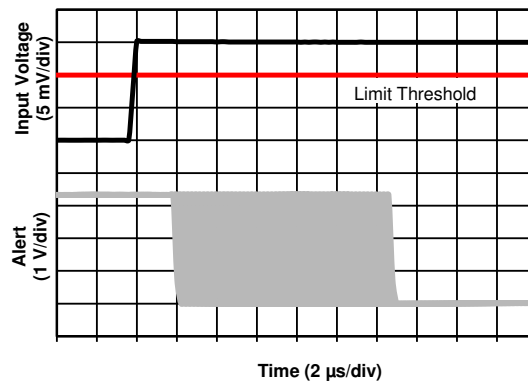

**Figure 8-2. Alert Response**

### 8.2.2 Bidirectional Operation

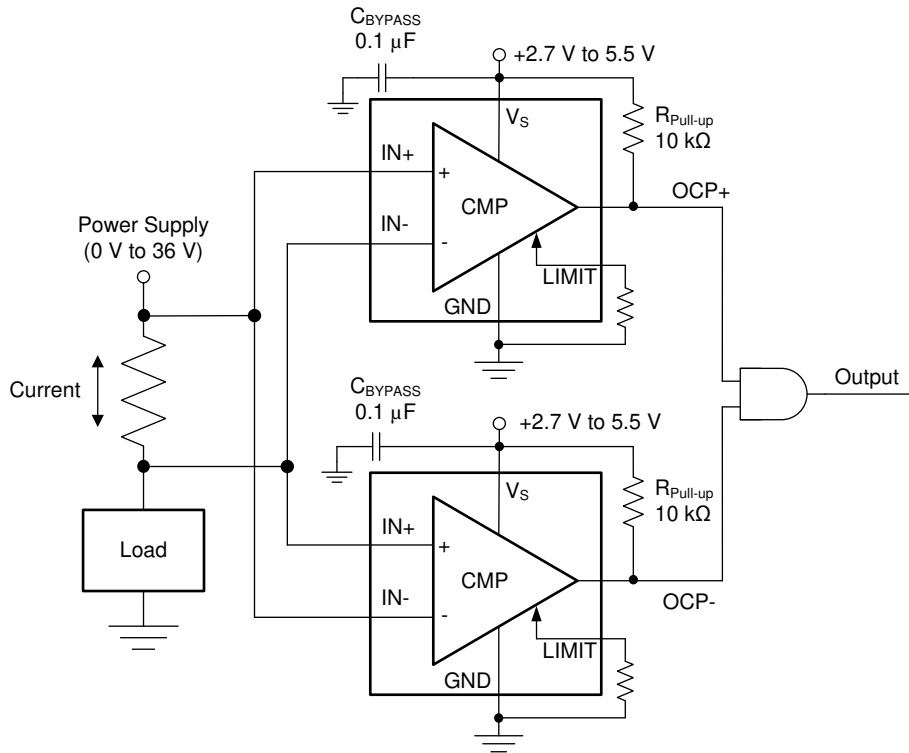

**图 8-3. Bidirectional Application**

#### 8.2.2.1 Design Requirements

Although the INA300 device is only able to measure current through a current-sensing resistor flowing in one direction, a second INA300 device can be used to create a bidirectional monitor.

#### 8.2.2.2 Detailed Design Procedure

With the input terminals of a second INA300 device reversed across the same current-sensing resistor, the second INA300 device is now able to detect current flowing in the other direction relative to the first device, as shown in [图 8-3](#). The outputs of each INA300 device connect to an AND gate to detect if either of the limit threshold levels are exceeded. The output of the AND gate is high if neither overcurrent limit thresholds are exceeded. A low output state of the AND gate indicates that either the positive overcurrent limit or the negative overcurrent limit are surpassed.

**表 8-1. Bidirectional Overcurrent Output Status**

OCP STATUS	OUTPUT
OCP+	0
OCP-	0
No OCP	1



### 8.2.2.3 Application Curve

☒ 8-4 illustrates two INA300 INA300 devices being used in a bidirectional configuration and an output control circuit to detect if one of the two alerts is exceeded.

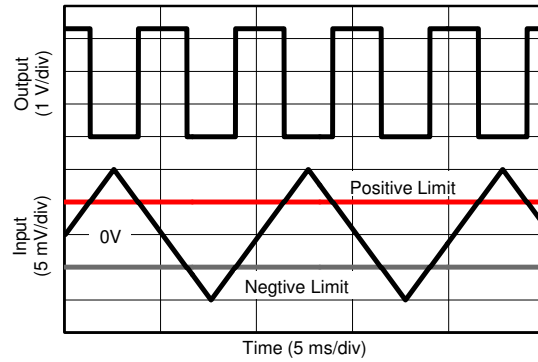

☒ 8-4. Bidirectional Application Curve

### 8.2.3 Window Comparator

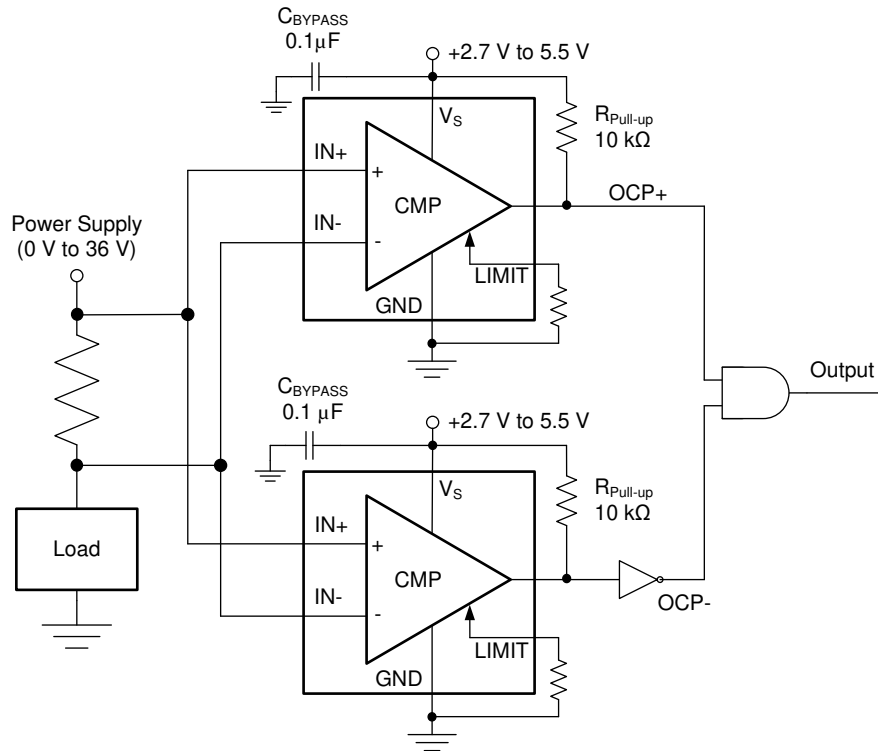

**图 8-5. Window Comparator Application**

#### 8.2.3.1 Design Requirements

The INA300 device can be used to create a window comparator function, detecting whether the current being monitored is within a programmed range or has fallen outside of the expected operating region.

#### 8.2.3.2 Detailed Design Procedure

图 8-5 shows how the window comparator function is setup using two INA300 devices. The input terminals of each INA300 device are connected to the same current-sensing resistor. The limit threshold for the top device is set to the upper limit of the window range. The bottom device limit threshold is set to the desired lower limit of the range. With a logic inverter placed at the output of the device monitoring the lower limit, the OCP- signal is high when the input signal is above the lower limit threshold. The OCP+ signal is high when the input signal is below the upper limit threshold. A high value at the output (output of the AND gate) indicates that the monitored current is operating within the desired window range.

**表 8-2. Window Comparator Output Status**

INPUT CONDITION	OUTPUT STATUS
Above range	0
Below range	0
In range	1

### 8.2.3.3 Application Curve

Figure 8-6 shows the output waveform from the device window comparator application. In Figure 8-6, the output signal is high when OCP<sup>-</sup> is low (the input signal is above the lower limit) and when OCP<sup>+</sup> is high (the input signal is below the upper limit). If the signal rises above the upper limit or drops below the lower limit, the corresponding OCP output changes state, causing the state of the output (following the AND gate) to change to zero to indicate an out-of-range condition.

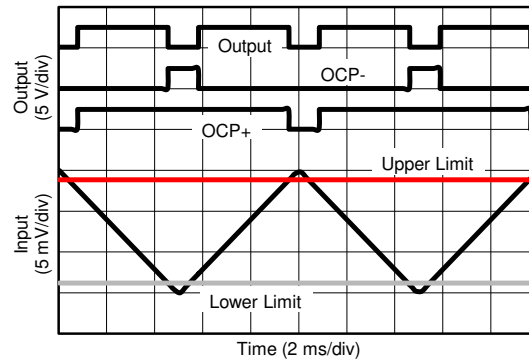

Figure 8-6. Output Waveform

## 9 Power Supply Recommendations

The INA300 device input circuitry can accurately measure signals on common-mode voltages beyond the power-supply voltage,  $V_S$ . For example, the voltage applied to the  $V_S$  power-supply terminal can be 5 V, whereas the load power-supply voltage being monitored ( $V_{CM}$ ) can be as high as 36 V. Note that the INA300 device can withstand the full  $-0.3$  V to  $+36$  V range at the input terminals, regardless of whether the device has power applied or not.

Power-supply bypass capacitors are required for stability and must be placed as closely as possible to the supply and ground terminals of the device. A typical value for this supply bypass capacitor is  $0.1 \mu\text{F}$ . Applications with noisy or high-impedance power supplies may require additional decoupling capacitors to reject power-supply noise.

## 10 Layout

### 10.1 Layout Guidelines

- The power-supply bypass capacitor must be placed as closely as possible to the supply and ground terminals. The recommended value of this bypass capacitor is 0.1  $\mu\text{F}$ . Additional decoupling capacitance can be added to compensate for noisy or high-impedance power supplies.
- The connection of  $R_{\text{LIMIT}}$  to the ground terminal must be made as direct as possible to limit additional capacitance on this node. Routing this connection must be limited to the same plane if possible avoiding vias to internal planes. If the routing cannot be made on the same plane and must pass through vias, ensure that a path is routed from the  $R_{\text{LIMIT}}$  back to the ground terminal and that the  $R_{\text{LIMIT}}$  is not connected directly to a ground plane.
- The DELAY terminal must be either connected directly to ground, directly to supply, or left completely floating. Additional external resistors must not be connected to this terminal. If a resistance is required by the application to be placed in series with either the supply or ground connection to the DELAY terminal, this resistance must be limited to 1 k $\Omega$  so as to not conflict with the internal level detection circuitry.
- The HYS terminal must be either connected directly to ground, directly to supply, or left completely floating. Additional external resistors must not be connected to this terminal. If a resistance is required by the application to be placed in series with either the supply or ground connections to the HYS terminal, this resistance must be limited to 1 k $\Omega$  so as to not conflict with the internal level detection circuitry.
- The open-drain output pin is recommended to be pulled up to the supply voltage rail through a 10-k $\Omega$  pull-up resistor.

## 10.2 Layout Example

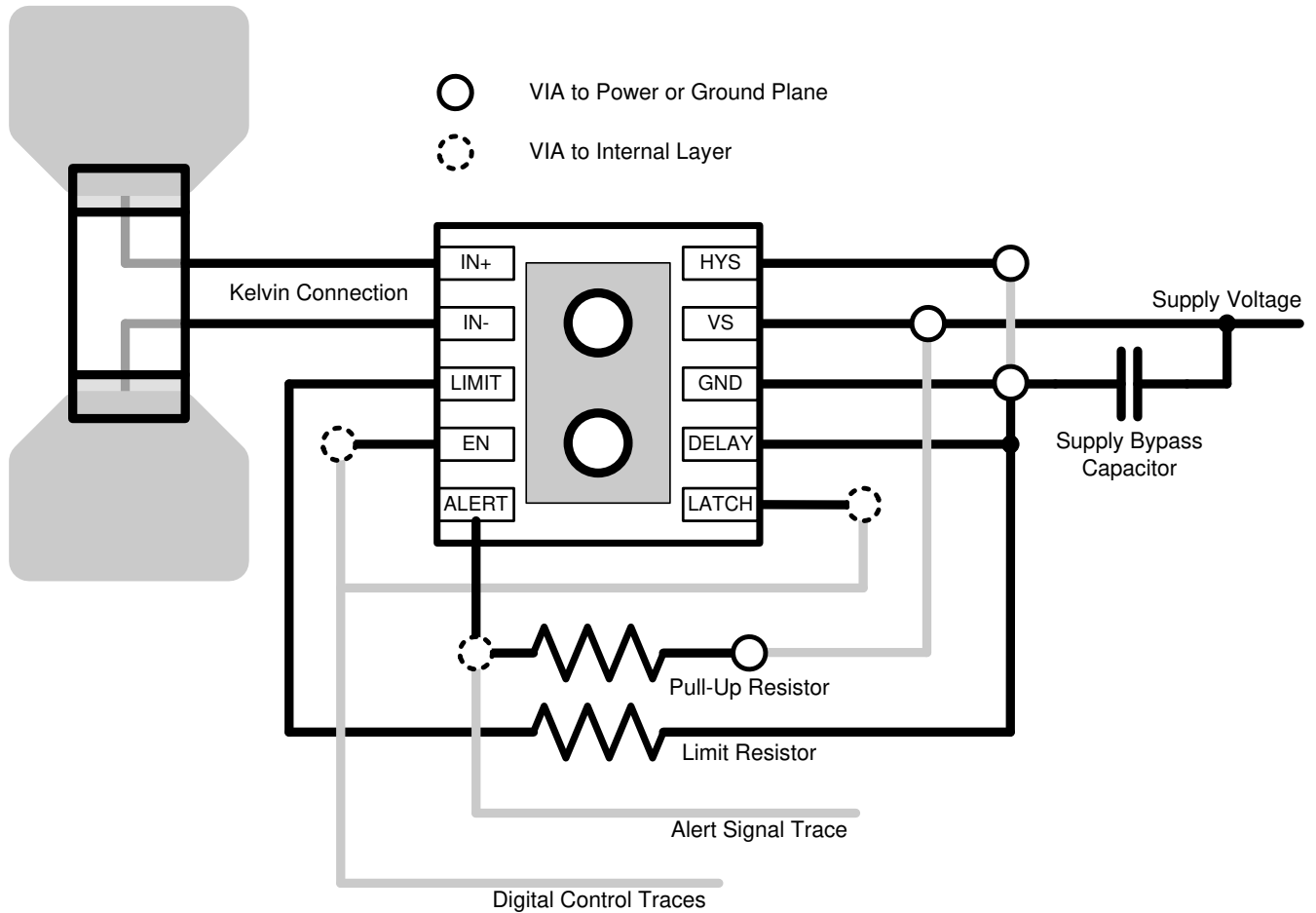

NOTE: Connect the limit resistor directly to the GND terminal.

**10-1. Recommended Layout for WSON Package**

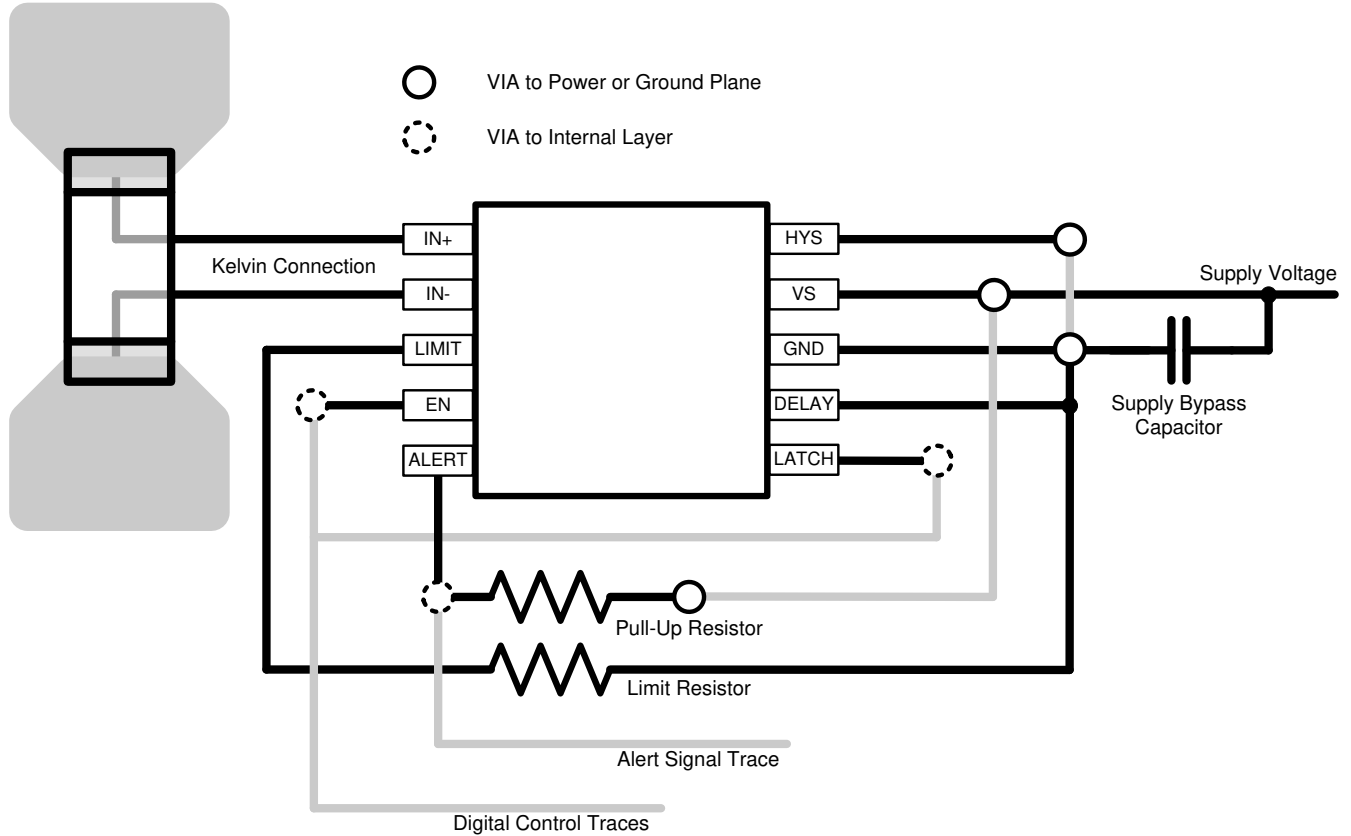

NOTE: Connect the limit resistor directly to the GND terminal.

**10-2. Recommended Layout for VSSOP Package**

## 11 Device and Documentation Support

### 11.1 Documentation Support

#### 11.1.1 Related Documentation

For related documentation see the following:

- [INA300EVM User's Guide](#) (SBAU220).

### 11.2 Receiving Notification of Documentation Updates

To receive notification of documentation updates, navigate to the device product folder on [ti.com](http://ti.com). Click on *Subscribe to updates* to register and receive a weekly digest of any product information that has changed. For change details, review the revision history included in any revised document.

### 11.3 サポート・リソース

TI E2E™ サポート・フォーラムは、エンジニアが検証済みの回答と設計に関するヒントをエキスパートから迅速かつ直接得ることができる場所です。既存の回答を検索したり、独自の質問をしたりすることで、設計に必要な支援を迅速に得ることができます。

リンクされているコンテンツは、該当する貢献者により、現状のまま提供されるものです。これらは TI の仕様を構成するものではなく、必ずしも TI の見解を反映したものではありません。TI の [使用条件](#) を参照してください。

### 11.4 Trademarks

TI E2E™ is a trademark of Texas Instruments.

すべての商標は、それぞれの所有者に帰属します。

### 11.5 Electrostatic Discharge Caution



This integrated circuit can be damaged by ESD. Texas Instruments recommends that all integrated circuits be handled with appropriate precautions. Failure to observe proper handling and installation procedures can cause damage.

ESD damage can range from subtle performance degradation to complete device failure. Precision integrated circuits may be more susceptible to damage because very small parametric changes could cause the device not to meet its published specifications.

### 11.6 Glossary

[TI Glossary](#) This glossary lists and explains terms, acronyms, and definitions.

## 12 Mechanical, Packaging, and Orderable Information

The following pages include mechanical packaging and orderable information. This information is the most current data available for the designated devices. This data is subject to change without notice and revision of this document. For browser-based versions of this data sheet, refer to the left-hand navigation.



**PACKAGING INFORMATION**

Orderable Device	Status (1)	Package Type	Package Drawing	Pins	Package Qty	Eco Plan (2)	Lead finish/ Ball material (6)	MSL Peak Temp (3)	Op Temp (°C)	Device Marking (4/5)	Samples
INA300AIDGSR	ACTIVE	VSSOP	DGS	10	2500	RoHS & Green	NIPDAUAG   SN	Level-1-260C-UNLIM	-40 to 125	12T6	<a href="#">Samples</a>
INA300AIDGST	LIFEBUY	VSSOP	DGS	10	250	RoHS & Green	NIPDAUAG   SN	Level-1-260C-UNLIM	-40 to 125	12T6	
INA300AIDSQR	ACTIVE	WSON	DSQ	10	3000	RoHS & Green	NIPDAU	Level-2-260C-1 YEAR	-40 to 125	SKD	<a href="#">Samples</a>
INA300AIDSQT	LIFEBUY	WSON	DSQ	10	250	RoHS & Green	NIPDAU	Level-2-260C-1 YEAR	-40 to 125	SKD	

(1) The marketing status values are defined as follows:

**ACTIVE:** Product device recommended for new designs.

**LIFEBUY:** TI has announced that the device will be discontinued, and a lifetime-buy period is in effect.

**NRND:** Not recommended for new designs. Device is in production to support existing customers, but TI does not recommend using this part in a new design.

**PREVIEW:** Device has been announced but is not in production. Samples may or may not be available.

**OBSOLETE:** TI has discontinued the production of the device.

(2) **RoHS:** TI defines "RoHS" to mean semiconductor products that are compliant with the current EU RoHS requirements for all 10 RoHS substances, including the requirement that RoHS substance do not exceed 0.1% by weight in homogeneous materials. Where designed to be soldered at high temperatures, "RoHS" products are suitable for use in specified lead-free processes. TI may reference these types of products as "Pb-Free".

**RoHS Exempt:** TI defines "RoHS Exempt" to mean products that contain lead but are compliant with EU RoHS pursuant to a specific EU RoHS exemption.

**Green:** TI defines "Green" to mean the content of Chlorine (Cl) and Bromine (Br) based flame retardants meet JS709B low halogen requirements of <=1000ppm threshold. Antimony trioxide based flame retardants must also meet the <=1000ppm threshold requirement.

(3) MSL, Peak Temp. - The Moisture Sensitivity Level rating according to the JEDEC industry standard classifications, and peak solder temperature.

(4) There may be additional marking, which relates to the logo, the lot trace code information, or the environmental category on the device.

(5) Multiple Device Markings will be inside parentheses. Only one Device Marking contained in parentheses and separated by a "~" will appear on a device. If a line is indented then it is a continuation of the previous line and the two combined represent the entire Device Marking for that device.

(6) Lead finish/Ball material - Orderable Devices may have multiple material finish options. Finish options are separated by a vertical ruled line. Lead finish/Ball material values may wrap to two lines if the finish value exceeds the maximum column width.

**Important Information and Disclaimer:**The information provided on this page represents TI's knowledge and belief as of the date that it is provided. TI bases its knowledge and belief on information provided by third parties, and makes no representation or warranty as to the accuracy of such information. Efforts are underway to better integrate information from third parties. TI has taken and continues to take reasonable steps to provide representative and accurate information but may not have conducted destructive testing or chemical analysis on incoming materials and chemicals. TI and TI suppliers consider certain information to be proprietary, and thus CAS numbers and other limited information may not be available for release.

In no event shall TI's liability arising out of such information exceed the total purchase price of the TI part(s) at issue in this document sold by TI to Customer on an annual basis.

**OTHER QUALIFIED VERSIONS OF INA300 :**

- Automotive : [INA300-Q1](#)

NOTE: Qualified Version Definitions:

- Automotive - Q100 devices qualified for high-reliability automotive applications targeting zero defects

**TAPE AND REEL INFORMATION**

**QUADRANT ASSIGNMENTS FOR PIN 1 ORIENTATION IN TAPE**

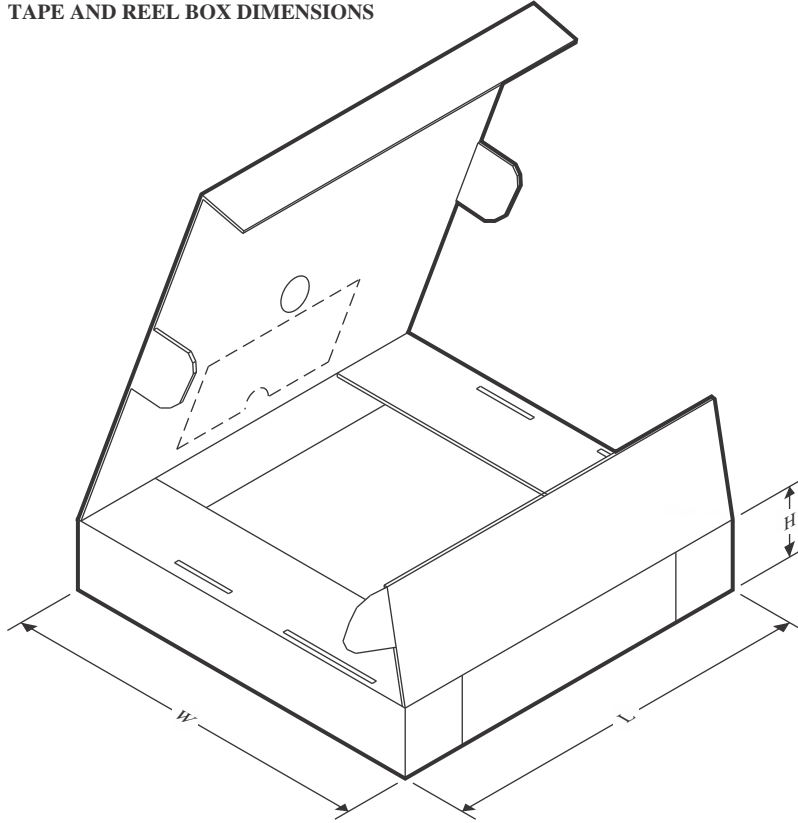

\*All dimensions are nominal

Device	Package Type	Package Drawing	Pins	SPQ	Reel Diameter (mm)	Reel Width W1 (mm)	A0 (mm)	B0 (mm)	K0 (mm)	P1 (mm)	W (mm)	Pin1 Quadrant
INA300AIDGSR	VSSOP	DGS	10	2500	330.0	12.4	5.25	3.35	1.25	8.0	12.0	Q1
INA300AIDGST	VSSOP	DGS	10	250	330.0	12.4	5.25	3.35	1.25	8.0	12.0	Q1
INA300AIDSQR	WSO	DSQ	10	3000	180.0	8.4	2.3	2.3	1.15	4.0	8.0	Q2
INA300AIDSQT	WSO	DSQ	10	250	180.0	8.4	2.3	2.3	1.15	4.0	8.0	Q2

**TAPE AND REEL BOX DIMENSIONS**

\*All dimensions are nominal

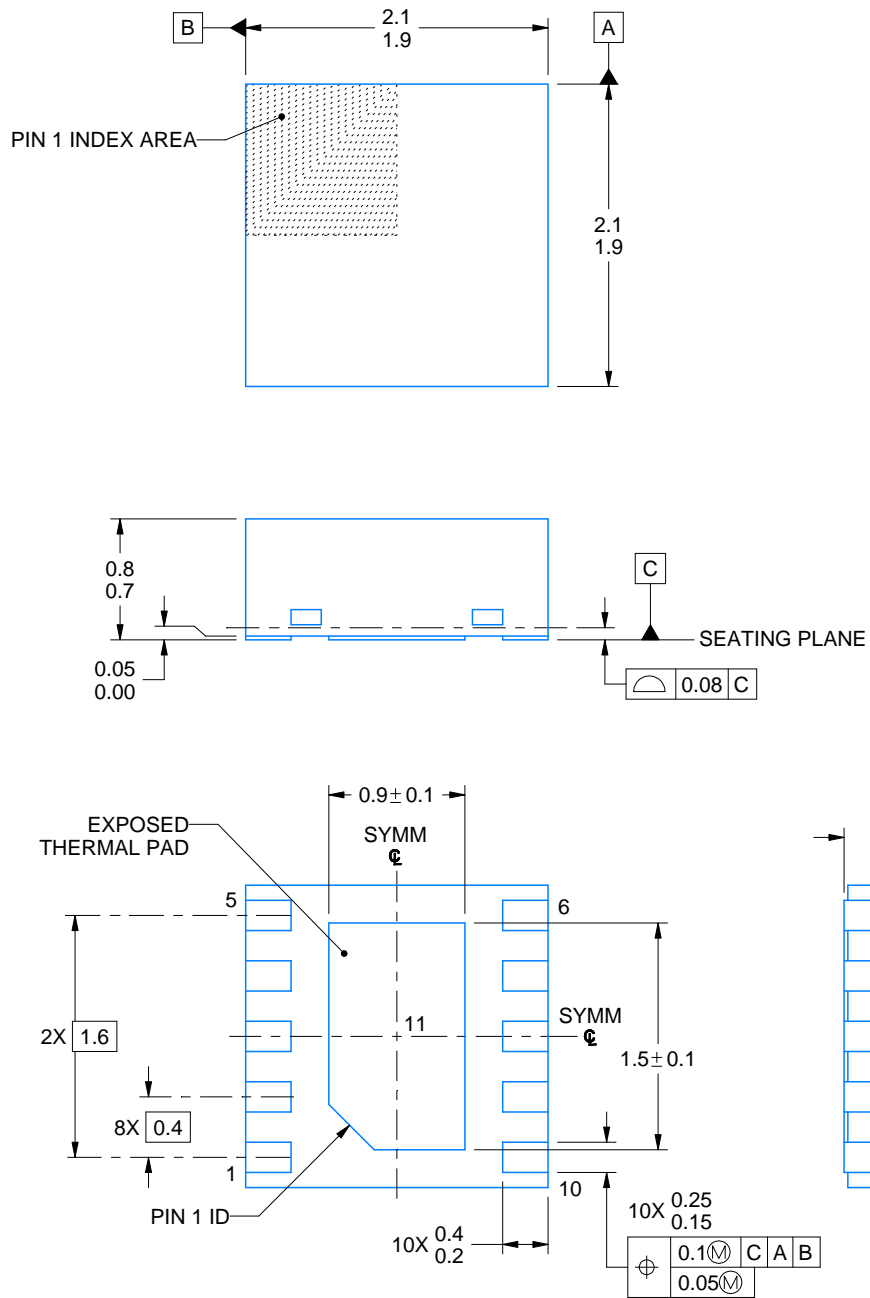
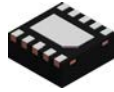
Device	Package Type	Package Drawing	Pins	SPQ	Length (mm)	Width (mm)	Height (mm)
INA300AIDGSR	VSSOP	DGS	10	2500	366.0	364.0	50.0
INA300AIDGST	VSSOP	DGS	10	250	366.0	364.0	50.0
INA300AIDSQR	WSON	DSQ	10	3000	210.0	185.0	35.0
INA300AIDSQT	WSON	DSQ	10	250	210.0	185.0	35.0



4218906/A 04/2019

NOTES:

1. All linear dimensions are in millimeters. Any dimensions in parenthesis are for reference only. Dimensioning and tolerancing per ASME Y14.5M.
2. This drawing is subject to change without notice.
3. The package thermal pad must be soldered to the printed circuit board for thermal and mechanical performance.

# EXAMPLE BOARD LAYOUT

DSQ0010A

WSON - 0.8 mm max height

PLASTIC SMALL OUTLINE - NO LEAD

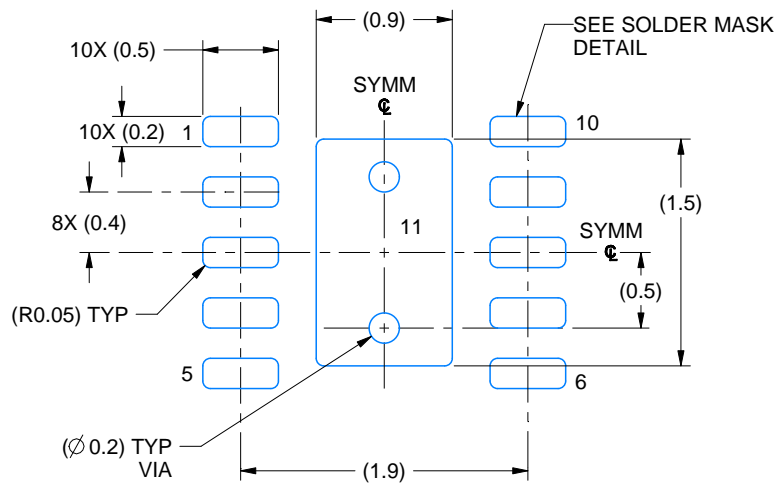

LAND PATTERN EXAMPLE  
EXPOSED METAL SHOWN  
SCALE: 20X



SOLDER MASK DETAILS

4218906/A 04/2019

NOTES: (continued)

- This package is designed to be soldered to a thermal pad on the board. For more information, see Texas Instruments literature number SLUA271 ([www.ti.com/lit/slua271](http://www.ti.com/lit/slua271)).
- Vias are optional depending on application, refer to device data sheet. If any vias are implemented, refer to their locations shown on this view. It is recommended that vias under paste be filled, plugged or tented.

# EXAMPLE STENCIL DESIGN

DSQ0010A

WSON - 0.8 mm max height

PLASTIC SMALL OUTLINE - NO LEAD



SOLDER PASTE EXAMPLE  
BASED ON 0.125 MM THICK STENCIL  
SCALE: 20X

EXPOSED PAD 11  
87% PRINTED SOLDER COVERAGE BY AREA UNDER PACKAGE

4218906/A 04/2019

NOTES: (continued)

6. Laser cutting apertures with trapezoidal walls and rounded corners may offer better paste release. IPC-7525 may have alternate design recommendations.

# DGS0010A



# PACKAGE OUTLINE

## VSSOP - 1.1 mm max height

SMALL OUTLINE PACKAGE



**NOTES:**

1. All linear dimensions are in millimeters. Any dimensions in parenthesis are for reference only. Dimensioning and tolerancing per ASME Y14.5M.
2. This drawing is subject to change without notice.
3. This dimension does not include mold flash, protrusions, or gate burrs. Mold flash, protrusions, or gate burrs shall not exceed 0.15 mm per side.
4. This dimension does not include interlead flash. Interlead flash shall not exceed 0.25 mm per side.
5. Reference JEDEC registration MO-187, variation BA.



# EXAMPLE BOARD LAYOUT

DGS0010A

VSSOP - 1.1 mm max height

SMALL OUTLINE PACKAGE



LAND PATTERN EXAMPLE  
SCALE:10X

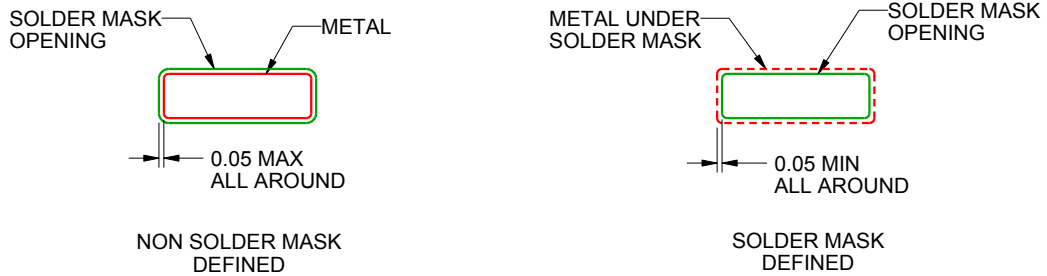

SOLDER MASK DETAILS  
NOT TO SCALE

4221984/A 05/2015

NOTES: (continued)

6. Publication IPC-7351 may have alternate designs.
7. Solder mask tolerances between and around signal pads can vary based on board fabrication site.

# EXAMPLE STENCIL DESIGN

DGS0010A

VSSOP - 1.1 mm max height

SMALL OUTLINE PACKAGE



SOLDER PASTE EXAMPLE  
BASED ON 0.125 mm THICK STENCIL  
SCALE:10X

4221984/A 05/2015

NOTES: (continued)

8. Laser cutting apertures with trapezoidal walls and rounded corners may offer better paste release. IPC-7525 may have alternate design recommendations.
9. Board assembly site may have different recommendations for stencil design.

## 重要なお知らせと免責事項

テキサス・インスツルメンツは、技術データと信頼性データ(データシートを含みます)、設計リソース(リファレンス デザインを含みます)、アプリケーションや設計に関する各種アドバイス、Web ツール、安全性情報、その他のリソースを、欠陥が存在する可能性のある「現状のまま」提供しており、商品性および特定目的に対する適合性の黙示保証、第三者の知的財産権の非侵害保証を含むいかなる保証も、明示的または黙示的にかかわらず拒否します。

これらのリソースは、テキサス・インスツルメンツ製品を使用する設計の経験を積んだ開発者への提供を意図したものです。(1) お客様のアプリケーションに適したテキサス・インスツルメンツ製品の選定、(2) お客様のアプリケーションの設計、検証、試験、(3) お客様のアプリケーションに該当する各種規格や、その他のあらゆる安全性、セキュリティ、規制、または他の要件への確実な適合に関する責任を、お客様のみが単独で負うものとします。

上記の各種リソースは、予告なく変更される可能性があります。これらのリソースは、リソースで説明されているテキサス・インスツルメンツ製品を使用するアプリケーションの開発の目的でのみ、テキサス・インスツルメンツはその使用をお客様に許諾します。これらのリソースに関して、他の目的で複製することや掲載することは禁止されています。テキサス・インスツルメンツや第三者の知的財産権のライセンスが付与されている訳ではありません。お客様は、これらのリソースを自身で使用した結果発生するあらゆる申し立て、損害、費用、損失、責任について、テキサス・インスツルメンツおよびその代理人を完全に補償するものとし、テキサス・インスツルメンツは一切の責任を拒否します。

テキサス・インスツルメンツの製品は、[テキサス・インスツルメンツの販売条件](#)、または [ti.com](https://www.ti.com) やかかるテキサス・インスツルメンツ製品の関連資料などのいずれかを通じて提供する適用可能な条項の下で提供されています。テキサス・インスツルメンツがこれらのリソースを提供することは、適用されるテキサス・インスツルメンツの保証または他の保証の放棄の拡大や変更を意味するものではありません。

お客様がいかなる追加条項または代替条項を提案した場合でも、テキサス・インスツルメンツはそれらに異議を唱え、拒否します。

郵送先住所：Texas Instruments, Post Office Box 655303, Dallas, Texas 75265  
Copyright © 2025, Texas Instruments Incorporated