

ISO5852S 高 CMTI 2.5A/5A 強化絶縁型 IGBT、MOSFET ゲート・ドライバ、 分割出力とアクティブ保護機能を搭載

1 特長

- $V_{CM} = 1500V$ での最小同相過渡耐性 (CMTI): 100kV/ μs
- 分割出力により 2.5A のピーク・ソース電流および 5A のピーク・シンク電流を供給
- 短い伝搬遅延: 76ns (標準値)、110ns (最大値)
- 2A のアクティブ・ミラー・クランプ
- 出力短絡クランプ
- 短絡時のソフト電源オフ (STO) 機能
- 不飽和化検出時のフォルト・アラームは \overline{FLT} により通知され、 \overline{RST} によりリセット
- 入出力低電圧誤動作防止 (UVLO): レディ (RDY) ピンによる標示付き
- 低電源またはフローティング入力時の、アクティブ出力プルダウンおよびデフォルト Low 出力
- 入力電源電圧: 2.25V~5.5V
- 出力ドライバ供給電圧: 15V~30V
- CMOS 互換の入力
- 20ns 未満の入力パルスと過渡ノイズを除去
- 動作温度: -40°C~+125°C (周囲)
- 絶縁サージ耐久電圧 12800V_{PK}
- 安全関連の認定:
 - 8000V_{PK} V_{IO}TM および 2121V_{PK} V_{IO}RM の、DIN V VDE V 0884-10 (VDE V 0884-10):2006-12 準拠の強化絶縁
 - UL1577 準拠で 5700V_{RMS} において 1 分間の絶縁
 - CSA Component Acceptance Notice 5A、IEC-60950-1、および IEC 60601-1 最終機器標準
 - EN 61010-1 および EN 60950-1 準拠の TUV 認定
 - GB4943.1-2011 CQC 認定

2 アプリケーション

- 次のような用途の絶縁型 IGBT および MOSFET ドライバ:
 - 産業用モーター制御ドライバ
 - 産業用電源
 - ソーラー・インバータ
 - HEV および EV の電源モジュール
 - 誘導加熱

3 概要

ISO5852S デバイスは、IGBT および MOSFET 用の 5.7kV_{RMS} 強化絶縁型ゲート・ドライバで、分割出力の OUTH と OUTL があり、2.5A のソース電流と 5A のシンク電流を供給できます。入力側は、単一の 2.25V~5.5V 電源で動作します。出力側では、最小 15V から最大 30V までの電源電圧範囲が使用できます。2 つの相補 CMOS 入力により、ゲート・ドライバの出力状態が制御されます。伝搬時間が 76ns と短いため、出力ステージを正確に制御できます。

内部不飽和化 (DESAT) フォルト検出により、IGBT が過電流状況にあることが認識されます。DESAT が検出されると、ミュート・ロジックによりアイソレータの出力がただちにブロックされ、ソフト電源オフ手順が開始されて、OUTH ピンがディセーブルされ、OUTL ピンが 2 μs の間 Low になります。OUTL ピンが、負の方向に最も大きい供給電圧である V_{EE2} との比較で 2V に達すると、ゲート・ドライバ出力が V_{EE2} の電位に強制的に設定され、IGBT はただちにオフになります。

製品情報 (1)

部品番号	パッケージ	本体サイズ (公称)
ISO5852S	SOIC (16)	10.30mm × 7.50mm

- (1) 利用可能なすべてのパッケージについては、このデータシートの末尾にある注文情報を参照してください。

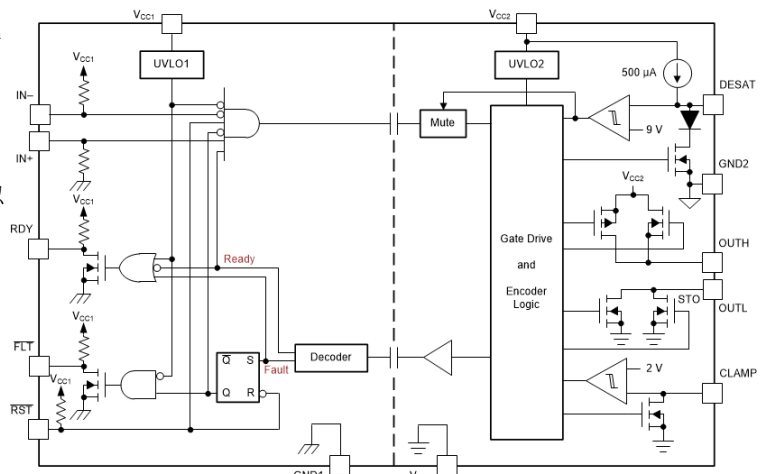

機能ブロック図



Table of Contents

1 特長	1	9.2 Functional Block Diagram.....	21
2 アプリケーション	1	9.3 Feature Description.....	22
3 概要	1	9.4 Device Functional Modes.....	23
4 Revision History	2	10 Application and Implementation	24
5 概要 (続き)	3	10.1 Application Information.....	24
6 Pin Configuration and Function	4	10.2 Typical Applications.....	24
7 Specifications	5	11 Power Supply Recommendations	33
7.1 Absolute Maximum Ratings.....	5	12 Layout	34
7.2 ESD Ratings.....	5	12.1 Layout Guidelines.....	34
7.3 Recommended Operating Conditions.....	5	12.2 Layout Example.....	34
7.4 Thermal Information.....	6	12.3 PCB Material.....	34
7.5 Power Ratings.....	6	13 Device and Documentation Support	35
7.6 Insulation Specifications.....	7	13.1 Device Support.....	35
7.7 Safety-Related Certifications.....	7	13.2 Documentation Support.....	35
7.8 Safety Limiting Values.....	8	13.3 ドキュメントの更新通知を受け取る方法.....	35
7.9 Electrical Characteristics.....	9	13.4 サポート・リソース.....	35
7.10 Switching Characteristics.....	10	13.5 Trademarks.....	35
7.11 Insulation Characteristics Curves.....	11	13.6 静電気放電に関する注意事項.....	35
7.12 Typical Characteristics.....	12	13.7 用語集.....	35
8 Parameter Measurement Information	19	14 Mechanical, Packaging, and Orderable Information	35
9 Detailed Description	21		
9.1 Overview.....	21		

4 Revision History

資料番号末尾の英字は改訂を表しています。その改訂履歴は英語版に準じています。

Changes from Revision B (January 2017) to Revision C (May 2023)	Page
• Added Additional manufacturing certification pending to Safety-Related Certifications table.....	8
Changes from Revision A (September 2015) to Revision B (January 2017)	Page
• データシートのタイトルを「アクティブ安全機能」から「アクティブ保護機能」に変更	1
• 「特長」の「サージ耐性 1200V _{PK} (IEC 61000-4-5 準拠)」を「絶縁サージ耐久電圧 1200V _{PK} 」に変更.....	1
• Changed the minimum external tracking (creepage) parameter to the external creepage parameter.....	7
• Changed the input-to-output test voltage parameter to the apparent charge parameter.....	7
• Added the climatic category to the <i>Insulation Specifications</i> table.....	7
• Changed the CSA status from planned to certified.....	8
• Added text ", but connecting CLAMP output of the gate driver to the IGBT gate is also not an issue." to <i>Supply and Active Miller Clamp</i>	22
• Changed the second paragraph of the <i>Typical Applications</i>	24
• Added text "and \overline{RST} input signal" to the <i>Design Requirements</i>	25
Changes from Revision * (July 2015) to Revision A (September 2015)	Page
• 「特長」の「100kV/ μ s の最小同相過渡耐性..」をリストの先頭に移動.....	1
• 1 ページの製品プレビューから完全なデータシートへ変更.....	1
• 「概要」のテキスト「単一の 3V~5.5V 電源」を「単一の 2.25V~5.5V 電源」に変更	1
• 「概要」のテキスト「IGBT は過負荷状態です」を「IGBT は過電流状態です」に変更	1
• 「概要」のテキスト「そして、OUTL の電圧を最小 2 μ s の期間にわたって低下させます」を「そして、OUTL を 2 μ s の期間にわたって Low にプルします」に変更	1
• 「機能ブロック図」を変更、ピン OUTL に STO を追加	1
• 「概要」の段落 3 を変更	3
• Changed the minimum air gap (clearance) parameter to the external clearance parameter.....	7

5 概要 (続き)

不飽和化がアクティブのとき、絶縁バリアを通してフォルト信号が送信され、入力側の $\overline{\text{FLT}}$ 出力が **Low** になって、アイソレータ入力がブロックされます。ソフト電源オフ期間の間は、ミュート・ロジックがアクティブになります。 $\overline{\text{FLT}}$ 出力状態はラッチされ、RDY ピンが **High** に移行した後でのみ、 $\overline{\text{RST}}$ 入力の **Low** アクティブ・パルスを使用してリセット可能です。

バイポーラ電源による通常動作時に IGBT がオフになると、出力は V_{EE2} にハード・クランプされます。出力電源がユニポラの場合、アクティブなミラー・クランプを使用でき、低インピーダンスのパスを通してミラー電流をシンクできるため、高電圧の過渡状況で IGBT が動的にオンになることを防止できます。

ゲート・ドライバの動作準備は、入力側と出力側の電源を監視する 2 つの低電圧誤動作防止回路により制御されます。いずれかの側の電源が不十分な場合は RDY 出力が **Low** になり、そうでない場合はこの出力が **High** になります。

ISO5852S デバイスは、16 ピンの SOIC パッケージで供給されます。デバイスの動作は、 $-40^{\circ}\text{C} \sim +125^{\circ}\text{C}$ の周囲温度範囲について規定されています。

6 Pin Configuration and Function



图 6-1. DWV Package 16-Pin SOIC Top View

表 6-1. Pin Functions

PIN		I/O	DESCRIPTION
NAME	NO.		
CLAMP	7	O	Miller clamp output
DESAT	2	I	Desaturation voltage input
FLT	13	O	Fault output, active-low during DESAT condition
GND1	9	—	Input ground
	16		
GND2	3	—	Gate drive common. Connect to IGBT emitter.
IN+	10	I	Non-inverting gate drive voltage control input
IN-	11	I	Inverting gate drive voltage control input
OUTH	4	O	Positive gate drive voltage output
OUTL	6	O	Negative gate drive voltage output
RDY	12	O	Power-good output, active high when both supplies are good.
RST	14	I	Reset input, apply a low pulse to reset fault latch.
V _{CC1}	15	—	Positive input supply (2.25 V to 5.5 V)
V _{CC2}	5	—	Most positive output supply potential.
V _{EE2}	1	—	Output negative supply. Connect to GND2 for unipolar supply application.
	8		

7 Specifications

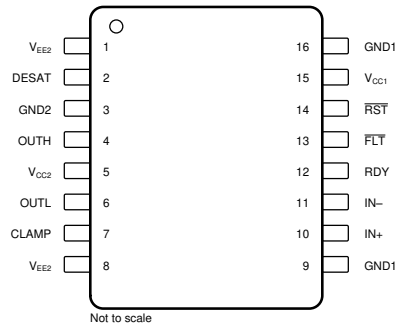
7.1 Absolute Maximum Ratings

Over operating free-air temperature range (unless otherwise noted)⁽¹⁾

			MIN	MAX	UNIT
V _{CC1}	Supply-voltage input side		GND1 – 0.3	6	V
V _{CC2}	Positive supply-voltage output side	(V _{CC2} – GND2)	–0.3	35	V
V _{EE2}	Negative supply-voltage output side	(V _{EE2} – GND2)	–17.5	0.3	V
V _(SUP2)	Total-supply output voltage	(V _{CC2} – V _{EE2})	–0.3	35	V
V _(OUTH)	Positive gate-driver output voltage		V _{EE2} – 0.3	V _{CC2} + 0.3	V
V _(OUTL)	Negative gate-driver output voltage		V _{EE2} – 0.3	V _{CC2} + 0.3	V
I _(OUTH)	Gate-driver high output current	Maximum pulse width = 10 μs, Maximum duty cycle = 0.2%		2.7	A
I _(OUTL)	Gate-driver low output current	Maximum pulse width = 10 μs, Maximum duty cycle = 0.2%		5.5	A
V _(LIP)	Voltage at IN+, IN–, FLT, RDY, RST		GND1 – 0.3	V _{CC1} + 0.3	V
I _(LOP)	Output current of FLT, RDY			10	mA
V _(DESAT)	Voltage at DESAT		GND2 – 0.3	V _{CC2} + 0.3	V
V _(CLAMP)	Clamp voltage		V _{EE2} – 0.3	V _{CC2} + 0.3	V
T _J	Junction temperature		–40	150	°C
T _{STG}	Storage temperature		–65	150	°C

- (1) Stresses beyond those listed under *Absolute Maximum Ratings* may cause permanent damage to the device. These are stress ratings only, which do not imply functional operation of the device at these or any other conditions beyond those indicated under *Recommended Operating Conditions*. Exposure to absolute-maximum-rated conditions for extended periods may affect device reliability.

7.2 ESD Ratings

			VALUE	UNIT
V _(ESD)	Electrostatic discharge	Human body model (HBM), per ANSI/ESDA/JEDEC JS-001 ⁽¹⁾	±4000	V
		Charged-device model (CDM), per JEDEC specification JESD22-C101 ⁽²⁾	±1500	

- (1) JEDEC document JEP155 states that 500-V HBM allows safe manufacturing with a standard ESD control process.
(2) JEDEC document JEP157 states that 250-V CDM allows safe manufacturing with a standard ESD control process.

7.3 Recommended Operating Conditions

over operating free-air temperature range (unless otherwise noted)

			MIN	NOM	MAX	UNIT
V _{CC1}	Supply-voltage input side		2.25		5.5	V
V _{CC2}	Positive supply-voltage output side	(V _{CC2} – GND2)	15		30	V
V _(EE2)	Negative supply-voltage output side	(V _{EE2} – GND2)	–15		0	V
V _(SUP2)	Total supply-voltage output side	(V _{CC2} – V _{EE2})	15		30	V
V _(IH)	High-level input voltage	(IN+, IN–, RST)	0.7 × V _{CC1}		V _{CC1}	V
V _(IL)	Low-level input voltage	(IN+, IN–, RST)	0		0.3 × V _{CC1}	V
t _{UI}	Pulse width at IN+, IN– for full output	(C _{LOAD} = 1 nF)	40			ns
t _{RST}	Pulse width at RST for resetting fault latch		800			ns
T _A	Ambient temperature		–40		125	°C

7.4 Thermal Information

THERMAL METRIC ⁽¹⁾		ISO5852S	UNIT
		DWW (SOIC)	
		16 PINS	
$R_{\theta JA}$	Junction-to-ambient thermal resistance	99.6	°C/W
$R_{\theta JC(top)}$	Junction-to-case (top) thermal resistance	48.5	°C/W
$R_{\theta JB}$	Junction-to-board thermal resistance	56.5	°C/W
Ψ_{JT}	Junction-to-top characterization parameter	29.2	°C/W
Ψ_{JB}	Junction-to-board characterization parameter	56.5	°C/W

(1) For more information about traditional and new thermal metrics, see the [Semiconductor and IC Package Thermal Metrics](#) application report.

7.5 Power Ratings

Full-chip power dissipation is derated 10.04 mW/°C beyond 25°C ambient temperature. At 125°C ambient temperature, a maximum of 251 mW total power dissipation is allowed. Power dissipation can be optimized depending on ambient temperature and board design, while ensuring that the junction temperature does not exceed 150°C.

PARAMETER		TEST CONDITIONS	MIN	TYP	MAX	UNIT
P_D	Maximum power dissipation (both sides)	$V_{CC1} = 5.5\text{ V}, V_{CC2} = 30\text{ V}, T_A = 25^\circ\text{C}$			1255	mW
P_{ID}	Maximum input power dissipation	$V_{CC1} = 5.5\text{ V}, V_{CC2} = 30\text{ V}, T_A = 25^\circ\text{C}$			175	mW
P_{OD}	Maximum output power dissipation	$V_{CC1} = 5.5\text{ V}, V_{CC2} = 30\text{ V}, T_A = 25^\circ\text{C}$			1080	mW

7.6 Insulation Specifications

PARAMETER		TEST CONDITIONS	VALUE	UNIT
GENERAL				
CLR	External clearance ⁽¹⁾	Shortest terminal-to-terminal distance through air	14.5	mm
CPG	External creepage ⁽¹⁾	Shortest terminal-to-terminal distance across the package surface	14.5	mm
DTI	Distance through the insulation	Minimum internal gap (internal clearance)	21	μm
CTI	Comparative tracking index	DIN EN 60112 (VDE 0303-11); IEC 60112; UL 746A	>600	V
	Material group	According to IEC 60664-1	I	
	Overvoltage Category	Rated mains voltage ≤ 600 V _{RMS}	I-IV	
		Rated mains voltage ≤ 1000 V _{RMS}	I-III	
DIN V VDE V 0884-10 (VDE V 0884-10):2006-12⁽²⁾				
V _{IORM}	Maximum repetitive peak isolation voltage	AC voltage (bipolar)	2828	V _{PK}
V _{IOWM}	Maximum isolation working voltage	AC voltage (sine wave) Time dependent dielectric breakdown (TDDb) test, see 7-1	2000	V _{RMS}
		DC voltage	2828	V _{DC}
V _{IOTM}	Maximum transient isolation voltage	V _{TEST} = V _{IOTM} ; t = 60 s (qualification); t = 1 s (100% production)	8000	V _{PK}
V _{IOSM}	Maximum surge isolation voltage ⁽³⁾	Test method per IEC 60065, 1.2/50 μs waveform, V _{TEST} = 1.6 × V _{IOSM} = 12800 V _{PK} (qualification)	8000	
q _{pd}	Apparent charge ⁽⁴⁾	Method a: After I/O safety test subgroup 2/3, V _{ini} = V _{IOTM} , t _{ini} = 60 s; V _{pd(m)} = 1.2 × V _{IORM} = 2545 V _{PK} , t _m = 10 s	≤5	pC
		Method a: After environmental tests subgroup 1, V _{ini} = V _{IOTM} , t _{ini} = 60 s; V _{pd(m)} = 1.6 × V _{IORM} = 3394 V _{PK} , t _m = 10 s	≤5	
		Method b1: At routine test (100% production) and preconditioning (type test) V _{ini} = V _{IOTM} , t _{ini} = 60 s; V _{pd(m)} = 1.875 × V _{IORM} = 3977 V _{PK} , t _m = 10 s	≤5	
C _{IO}	Barrier capacitance, input to output ⁽⁵⁾	V _{IO} = 0.4 sin (2πft), f = 1 MHz	~1	pF
R _{IO}	Isolation resistance, input to output ⁽⁵⁾	V _{IO} = 500 V, T _A = 25°C	> 10 ¹²	Ω
		V _{IO} = 500 V, 100°C ≤ T _A ≤ 125°C	> 10 ¹¹	
		V _{IO} = 500 V at T _S = 150°C	> 10 ⁹	
	Pollution degree		2	
	Climatic category		40/125/21	
UL 1577				
V _{ISO}	Withstand isolation voltage	V _{TEST} = V _{ISO} = 5700 V _{RMS} , t = 60 s (qualification); V _{TEST} = 1.2 × V _{ISO} = 6840 V _{RMS} , t = 1 s (100% production)	5700	V _{RMS}

- (1) Creepage and clearance requirements should be applied according to the specific equipment isolation standards of an application. Care should be taken to maintain the creepage and clearance distance of a board design to ensure that the mounting pads of the isolator on the printed-circuit board do not reduce this distance. Creepage and clearance on a printed-circuit board become equal in certain cases. Techniques such as inserting grooves and/or ribs on a printed circuit board are used to help increase these specifications.
- (2) This coupler is suitable for *safe electrical insulation* only within the maximum operating ratings. Compliance with the safety ratings shall be ensured by means of suitable protective circuits.
- (3) Testing is carried out in air or oil to determine the intrinsic surge immunity of the isolation barrier.
- (4) Apparent charge is electrical discharge caused by a partial discharge (pd).
- (5) All pins on each side of the barrier tied together creating a two-terminal device

7.7 Safety-Related Certifications

VDE	CSA	UL	CQC	TUV
Certified according to DIN V VDE V 0884-10 (VDE V 0884-10):2006-12 and DIN EN 61010-1 (VDE 0411-1):2011-07	Certified according to CSA Component Acceptance Notice 5A, IEC 60950-1, and IEC 60601-1	Recognized under UL 1577 Component Recognition Program	Certified according to GB4943.1-2011	Certified according to EN 61010-1:2010 (3rd Ed) and EN 60950-1:2006/A11:2009/A1:2010/A12:2011/A2:2013
Reinforced Insulation Maximum Transient isolation voltage, 8000 V _{PK} ; Maximum surge isolation voltage, 8000 V _{PK} ; Maximum repetitive peak isolation voltage, 2828 V _{PK}	Isolation Rating of 5700 V _{RMS} ; Reinforced insulation per CSA 60950-1-07+A1+A2 and IEC 60950-1 (2nd Ed.), 1450 V _{RMS} max working voltage (pollution degree 2, material group I) ; 2 MOPP (Means of Patient Protection) per CSA 60601-1:14 and IEC 60601-1 Ed. 3.1, 250 V _{RMS} (354 V _{PK}) max working voltage	Single Protection, 5700 V _{RMS}	Reinforced Insulation, Altitude ≤ 5000m, Tropical climate, 400 V _{RMS} maximum working voltage	5700 V _{RMS} Reinforced insulation per EN 61010-1:2010 (3rd Ed) up to working voltage of 1000 V _{RMS} 5700 V _{RMS} Reinforced insulation per EN 60950-1:2006/A11:2009/A1:2010/A12:2011/A2:2013 up to working voltage of 1450 V _{RMS}
Certification completed Certificate number: 40040142	Certification completed Master contract number: 220991	Certification completed File number: E181974	Certification completed Certificate number: CQC16001141761 Additional manufacturing certification pending	Certification completed Client ID number: 77311

7.8 Safety Limiting Values

Safety limiting intends to minimize potential damage to the isolation barrier upon failure of input or output circuitry. A failure of the I/O can allow low resistance to ground or the supply and, without current limiting, dissipate sufficient power to overheat the die and damage the isolation barrier, potentially leading to secondary system failures.

PARAMETER	TEST CONDITIONS	MIN	TYP	MAX	UNIT
I _S Safety input, output, or supply current	R _{θJA} = 99.6°C/W, V _I = 2.75 V, T _J = 150°C, T _A = 25°C, see 7-2			456	mA
	R _{θJA} = 99.6°C/W, V _I = 3.6 V, T _J = 150°C, T _A = 25°C, see 7-2			346	
	R _{θJA} = 99.6°C/W, V _I = 5.5 V, T _J = 150°C, T _A = 25°C, see 7-2			228	
	R _{θJA} = 99.6°C/W, V _I = 15 V, T _J = 150°C, T _A = 25°C, see 7-2			84	
	R _{θJA} = 99.6°C/W, V _I = 30 V, T _J = 150°C, T _A = 25°C, see 7-2			42	
P _S Safety input, output, or total power	R _{θJA} = 99.6°C/W, T _J = 150°C, T _A = 25°C, see 7-3			255 ⁽¹⁾	mW
T _S Maximum ambient safety temperature				150	°C

(1) Input, output, or the sum of input and output power should not exceed this value

The safety-limiting constraint is the maximum junction temperature specified in the data sheet. The power dissipation and junction-to-air thermal impedance of the device installed in the application hardware determines the junction temperature. The assumed junction-to-air thermal resistance in the [セクション 7.4](#) table is that of a device installed on a high-K test board for leaded surface-mount packages. The power is the recommended maximum input voltage times the current. The junction temperature is then the ambient temperature plus the power times the junction-to-air thermal resistance.

7.9 Electrical Characteristics

Over recommended operating conditions unless otherwise noted. All typical values are at $T_A = 25^\circ\text{C}$, $V_{CC1} = 5\text{ V}$, $V_{CC2} - \text{GND2} = 15\text{ V}$, $\text{GND2} - V_{EE2} = 8\text{ V}$

PARAMETER		TEST CONDITIONS	MIN	TYP	MAX	UNIT
VOLTAGE SUPPLY						
$V_{IT+(UVLO1)}$	Positive-going UVLO1 threshold-voltage input side ($V_{CC1} - \text{GND1}$)				2.25	V
$V_{IT-(UVLO1)}$	Negative-going UVLO1 threshold-voltage input side ($V_{CC1} - \text{GND1}$)		1.7			V
$V_{HYS(UVLO1)}$	UVLO1 Hysteresis voltage ($V_{IT+} - V_{IT-}$) input side			0.2		V
$V_{IT+(UVLO2)}$	Positive-going UVLO2 threshold-voltage output side ($V_{CC2} - \text{GND2}$)			12	13	V
$V_{IT-(UVLO2)}$	Negative-going UVLO2 threshold-voltage output side ($V_{CC2} - \text{GND2}$)		9.5	11		V
$V_{HYS(UVLO2)}$	UVLO2 hysteresis voltage ($V_{IT+} - V_{IT-}$) output side			1		V
I_{Q1}	Input-supply quiescent current			2.8	4.5	mA
I_{Q2}	Output-supply quiescent current			3.6	6	mA
LOGIC I/O						
$V_{IT+(IN, RST)}$	Positive-going input-threshold voltage ($IN+$, $IN-$, RST)				$0.7 \times V_{CC1}$	V
$V_{IT-(IN, RST)}$	Negative-going input-threshold voltage ($IN+$, $IN-$, RST)		$0.3 \times V_{CC1}$			V
$V_{HYS(IN, RST)}$	Input hysteresis voltage ($IN+$, $IN-$, RST)			$0.15 \times V_{CC1}$		V
I_{IH}	High-level input leakage at ($IN+$) ⁽¹⁾	$IN+ = V_{CC1}$		100		μA
I_{IL}	Low-level input leakage at ($IN-$, RST) ⁽²⁾	$IN- = \text{GND1}$, $RST = \text{GND1}$		-100		μA
I_{PU}	Pullup current of FLT , RDY	$V_{(RDY)} = \text{GND1}$, $V_{(FLT)} = \text{GND1}$		100		μA
$V_{(OL)}$	Low-level output voltage at FLT , RDY	$I_{(FLT)} = 5\text{ mA}$			0.2	V
GATE DRIVER STAGE						
$V_{(OUTPD)}$	Active output pulldown voltage	$I_{(OUTH/L)} = 200\text{ mA}$, $V_{CC2} = \text{open}$			2	V
V_{OUTH}	High-level output voltage	$I_{(OUTH)} = -20\text{ mA}$	$V_{CC2} - 0.5$	$V_{CC2} - 0.24$		V
V_{OUTL}	Low-level output voltage	$I_{(OUTL)} = 20\text{ mA}$		$V_{EE2} + 13$	$V_{EE2} + 50$	mV
$I_{(OUTH)}$	High-level output peak current	$IN+ = \text{high}$, $IN- = \text{low}$, $V_{(OUTH)} = V_{CC2} - 15\text{ V}$	1.5	2.5		A
$I_{(OUTL)}$	Low-level output peak current	$IN+ = \text{low}$, $IN- = \text{high}$, $V_{(OUTL)} = V_{EE2} + 15\text{ V}$	3.4	5		A
$I_{(OLF)}$	Low-level output current during fault condition			130		mA
ACTIVE MILLER CLAMP						
$V_{(CLP)}$	Low-level clamp voltage	$I_{(CLP)} = 20\text{ mA}$		$V_{EE2} + 0.015$	$V_{EE2} + 0.08$	V
$I_{(CLP)}$	Low-level clamp current	$V_{(CLAMP)} = V_{EE2} + 2.5\text{ V}$	1.6	2.5	3.3	A
$V_{(CLTH)}$	Clamp threshold voltage		1.6	2.1	2.5	V
SHORT CIRCUIT CLAMPING						
$V_{(CLP-OUTH)}$	Clamping voltage ($V_{OUTH} - V_{CC2}$)	$IN+ = \text{high}$, $IN- = \text{low}$, $t_{CLP} = 10\ \mu\text{s}$, $I_{(OUTH)} = 500\text{ mA}$		1.1	1.3	V
$V_{(CLP-OUTL)}$	Clamping voltage ($V_{OUTL} - V_{CC2}$)	$IN+ = \text{high}$, $IN- = \text{low}$, $t_{CLP} = 10\ \mu\text{s}$, $I_{(OUTL)} = 500\text{ mA}$		1.3	1.5	V
$V_{(CLP-CLP)}$	Clamping voltage ($V_{CLP} - V_{CC2}$)	$IN+ = \text{high}$, $IN- = \text{low}$, $t_{CLP} = 10\ \mu\text{s}$, $I_{(CLP)} = 500\text{ mA}$		1.3		V
$V_{(CLP-CLAMP)}$	Clamping voltage at CLAMP	$IN+ = \text{High}$, $IN- = \text{Low}$, $I_{(CLP)} = 20\text{ mA}$		0.7	1.1	V
$V_{(CLP-OUTL)}$	Clamping voltage at OUTL ($V_{CLP} - V_{CC2}$)	$IN+ = \text{High}$, $IN- = \text{Low}$, $I_{(OUTL)} = 20\text{ mA}$		0.7	1.1	V
DESAT PROTECTION						
$I_{(CHG)}$	Blanking-capacitor charge current	$V_{(DESAT)} - \text{GND2} = 2\text{ V}$	0.42	0.5	0.58	mA

7.9 Electrical Characteristics (continued)

Over recommended operating conditions unless otherwise noted. All typical values are at $T_A = 25^\circ\text{C}$, $V_{CC1} = 5\text{ V}$, $V_{CC2} = \text{GND2} = 15\text{ V}$, $\text{GND2} - V_{EE2} = 8\text{ V}$

PARAMETER		TEST CONDITIONS	MIN	TYP	MAX	UNIT
I_{DCHG}	Blanking-capacitor discharge current	$V_{\text{DESAT}} - \text{GND2} = 6\text{ V}$	9	14		mA
V_{DSTH}	DESAT threshold voltage with respect to GND2		8.3	9	9.5	V
V_{DSL}	DESAT voltage with respect to GND2, when OUTH or OUTL is driven low		0.4		1	V

- (1) I_{IH} for IN-, $\overline{\text{RST}}$ pin is zero as they are pulled high internally
 (2) I_{IL} for IN+ is zero, as it is pulled low internally

7.10 Switching Characteristics

Over recommended operating conditions unless otherwise noted. All typical values are at $T_A = 25^\circ\text{C}$, $V_{CC1} = 5\text{ V}$, $V_{CC2} = \text{GND2} = 15\text{ V}$, $\text{GND2} - V_{EE2} = 8\text{ V}$

PARAMETER		TEST CONDITIONS	MIN	TYP	MAX	UNIT
t_r	Output-signal rise time at OUTH	$C_{\text{LOAD}} = 1\text{ nF}$	12	18	35	ns
t_f	Output-signal fall time at OUTL	$C_{\text{LOAD}} = 1\text{ nF}$	12	20	37	ns
$t_{\text{PLH}}, t_{\text{PHL}}$	Propagation Delay	$C_{\text{LOAD}} = 1\text{ nF}$		76	110	ns
$t_{\text{sk-p}}$	Pulse skew $ t_{\text{PHL}} - t_{\text{PLH}} $	$C_{\text{LOAD}} = 1\text{ nF}$			20	ns
$t_{\text{sk-pp}}$	Part-to-part skew	$C_{\text{LOAD}} = 1\text{ nF}$			30 ⁽¹⁾	ns
$t_{\text{GF}} (\text{IN}/\overline{\text{RST}})$	Glitch filter on IN+, IN-, $\overline{\text{RST}}$	$C_{\text{LOAD}} = 1\text{ nF}$	20	30	40	ns
$t_{\text{DS}} (90\%)$	DESAT sense to 90% $V_{\text{OUTH/L}}$ delay	$C_{\text{LOAD}} = 10\text{ nF}$		553	760	ns
$t_{\text{DS}} (10\%)$	DESAT sense to 10% $V_{\text{OUTH/L}}$ delay	$C_{\text{LOAD}} = 10\text{ nF}$		2	3.5	μs
$t_{\text{DS}} (\text{GF})$	DESAT-glitch filter delay	$C_{\text{LOAD}} = 1\text{ nF}$		330		ns
$t_{\text{DS}} (\overline{\text{FLT}})$	DESAT sense to $\overline{\text{FLT}}$ -low delay	See 8-3			1.4	μs
t_{LEB}	Leading-edge blanking time	See 8-1 and 8-2	310	400	480	ns
$t_{\text{GF}} (\overline{\text{RSTFLT}})$	Glitch filter on $\overline{\text{RST}}$ for resetting $\overline{\text{FLT}}$		300		800	ns
C_i	Input capacitance ⁽²⁾	$V_i = V_{CC1} / 2 + 0.4 \times \sin(2\pi ft)$, $f = 1\text{ MHz}$, $V_{CC1} = 5\text{ V}$		2		pF
CMTI	Common-mode transient immunity	$V_{\text{CM}} = 1500\text{ V}$, see 8-4	100	120		kV/ μs

- (1) Measured at same supply voltage and temperature condition
 (2) Measured from input pin to ground.

7.11 Insulation Characteristics Curves

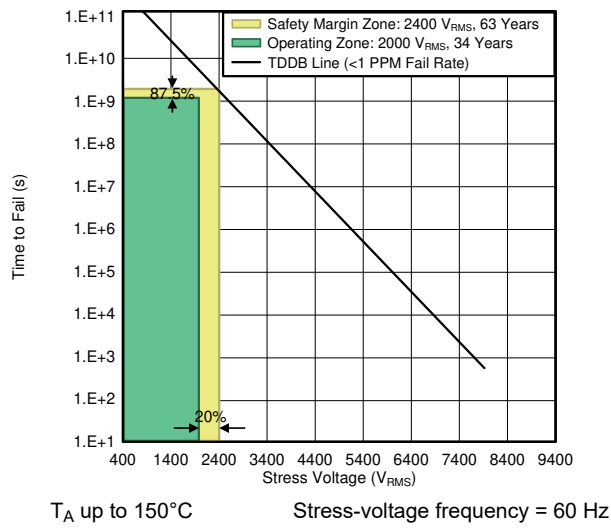

7-1. Reinforced Isolation Capacitor Lifetime Projection

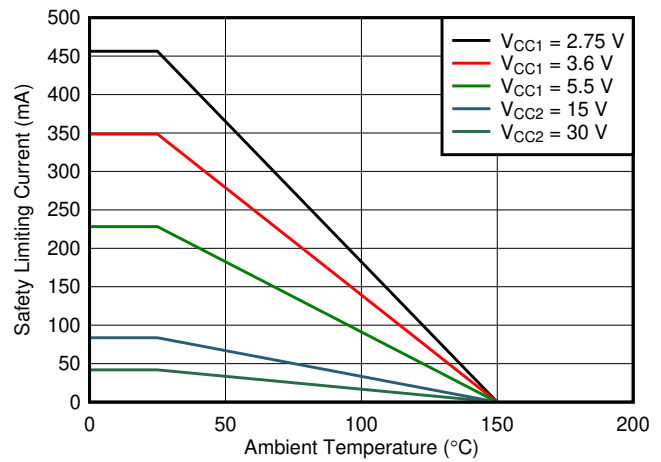

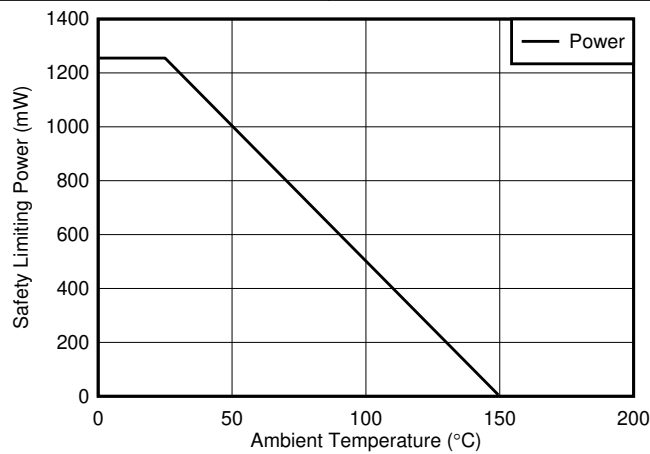

7-2. Thermal Derating Curve for Limiting Current per VDE



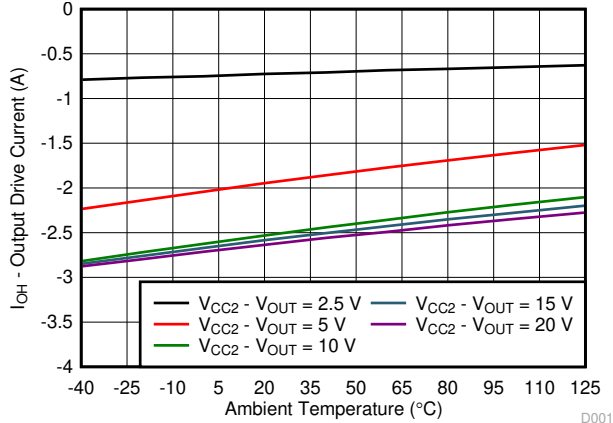

7-3. Thermal Derating Curve for Limiting Power per VDE

7.12 Typical Characteristics

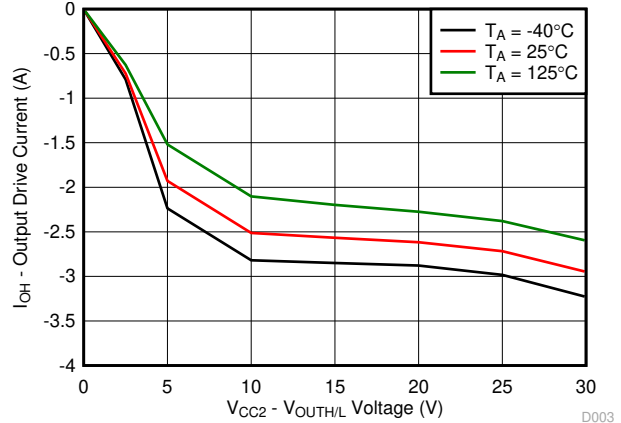

7-4. Output High Drive Current vs Temperature



7-5. Output High Drive Current vs Output Voltage

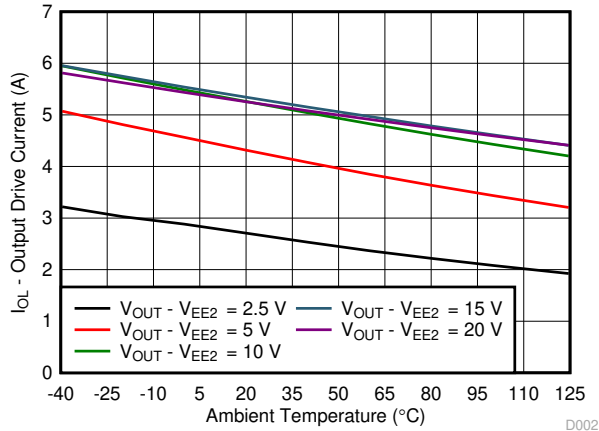

7-6. Output Low Drive Current vs Temperature

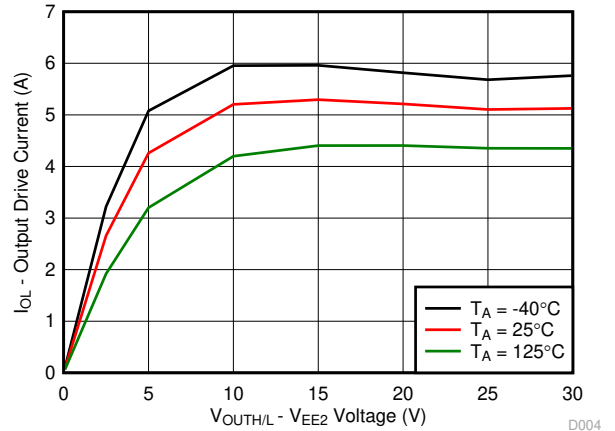

7-7. Output Low Drive Current vs Output Voltage

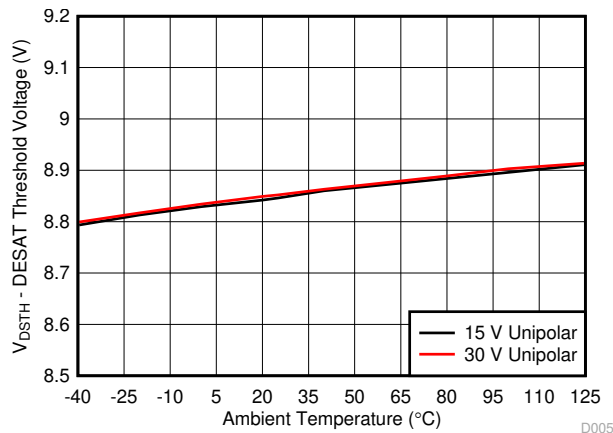

7-8. DESAT Threshold Voltage vs Temperature
Unipolar: $V_{CC2} - V_{EE2} = V_{CC2} - GND2$

7.12 Typical Characteristics (continued)

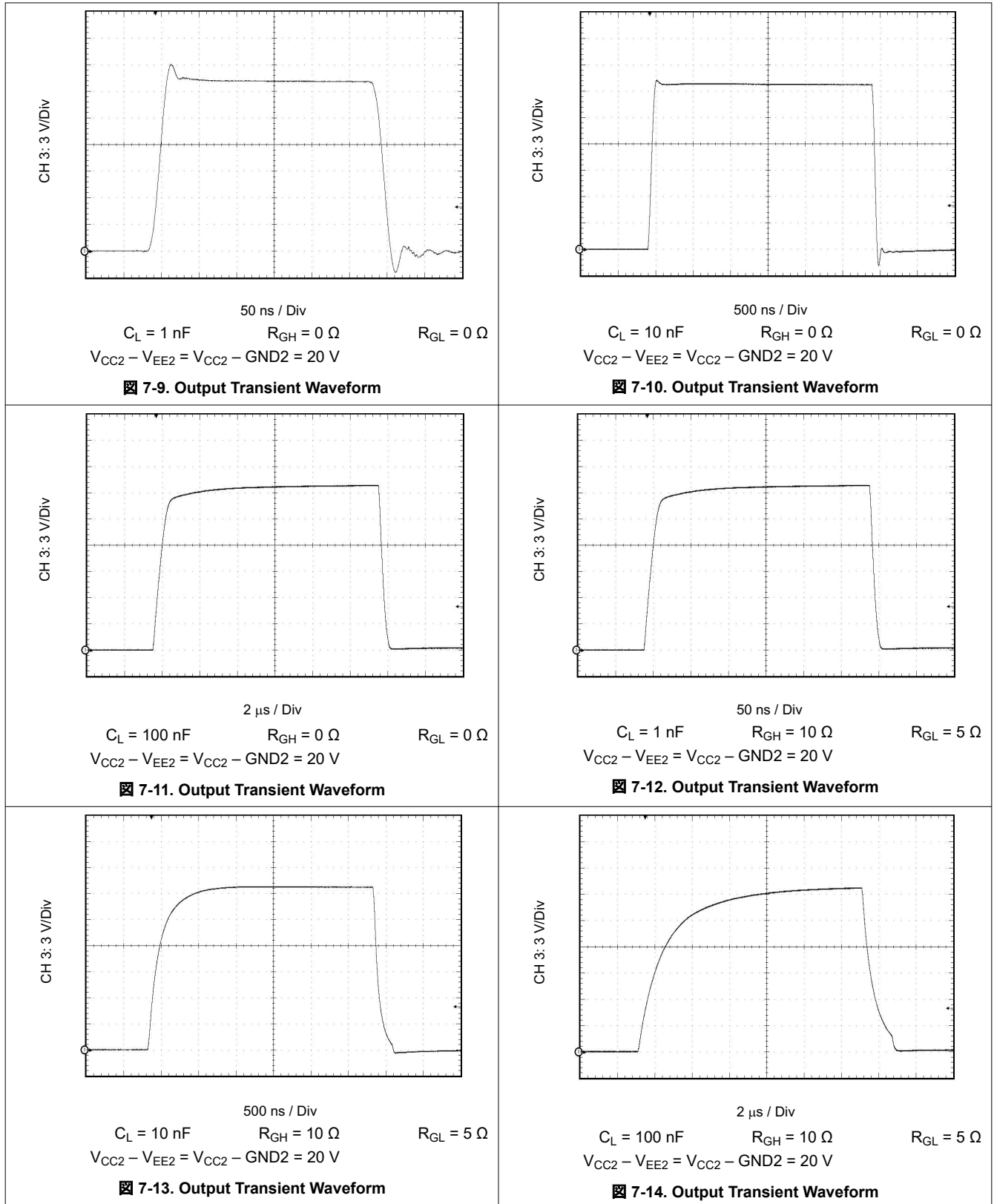

7.12 Typical Characteristics (continued)

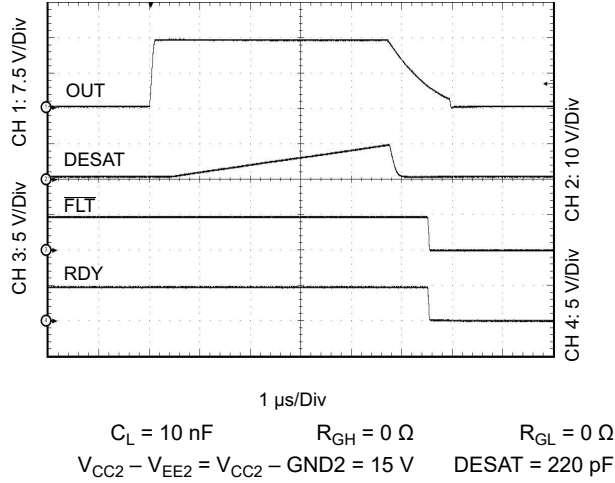

7-15. Output Transient Waveform DESAT, RDY, and \overline{FLT}

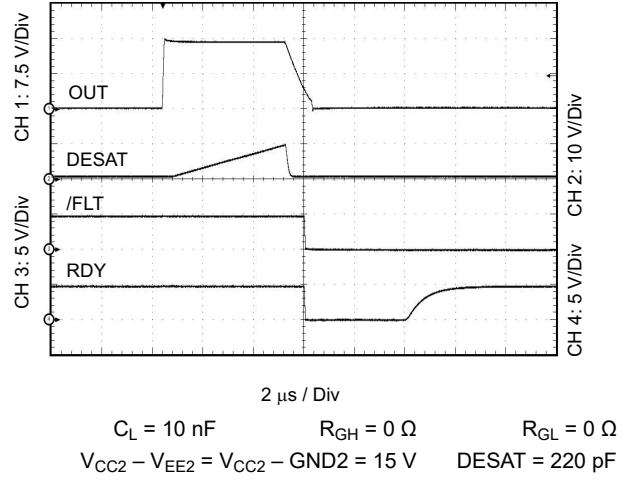

7-16. Output Transient Waveform DESAT, RDY, and \overline{FLT}

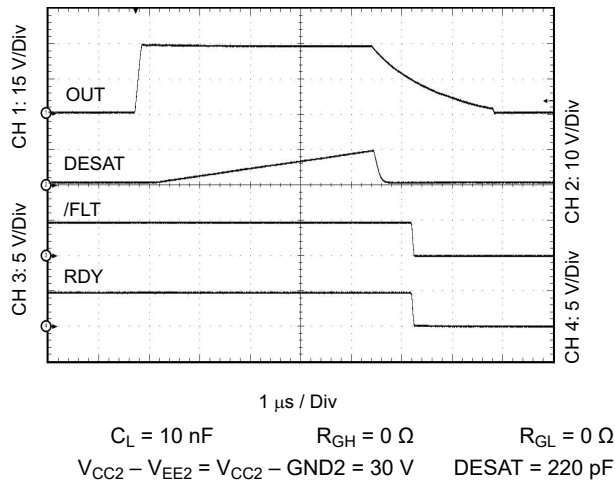

7-17. Output Transient Waveform DESAT, RDY, and \overline{FLT}

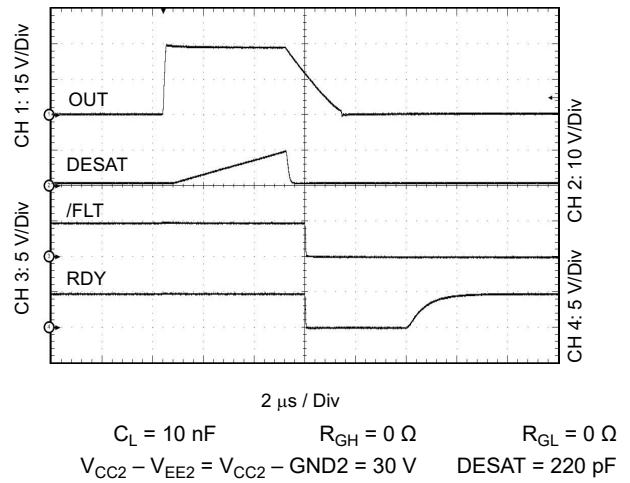

7-18. Output Transient Waveform DESAT, RDY, and \overline{FLT}

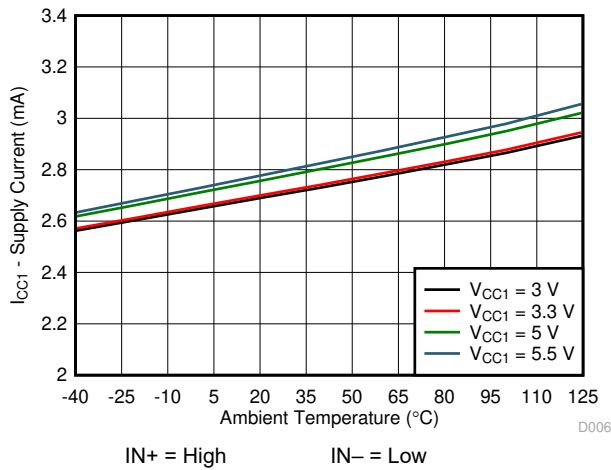

7-19. I_{CC1} Supply Current vs Temperature

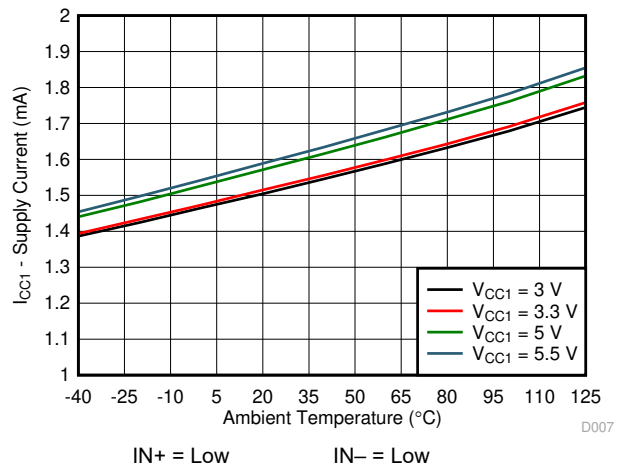

7-20. I_{CC1} Supply Current vs Temperature

7.12 Typical Characteristics (continued)

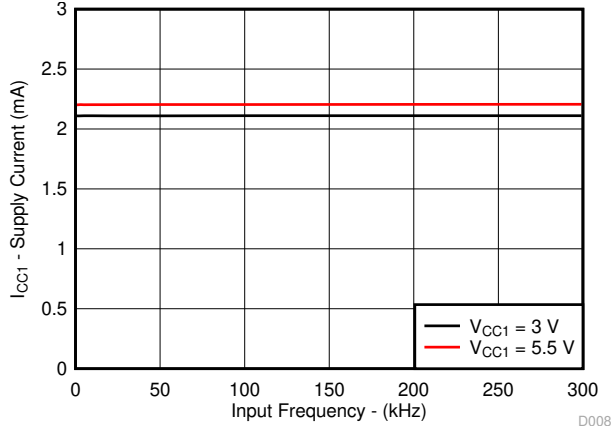

7-21. I_{CC1} Supply Current vs Input Frequency

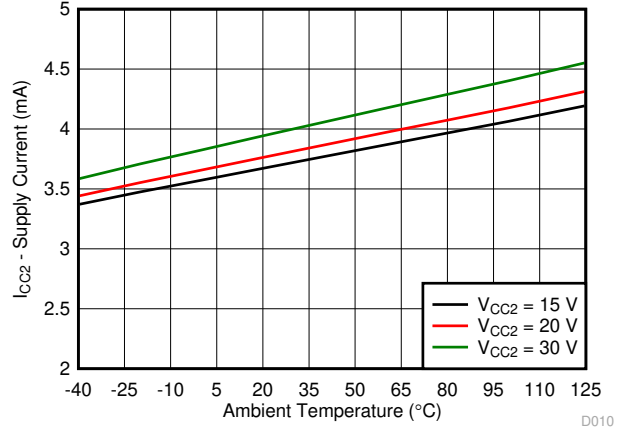

Input frequency = 1 kHz

7-22. I_{CC2} Supply Current vs Temperature

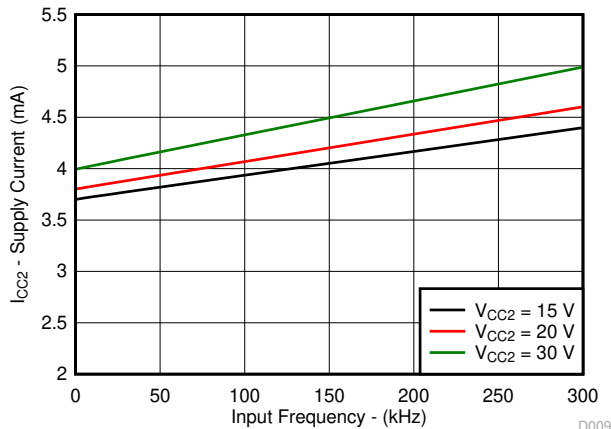

No C_L

7-23. I_{CC2} Supply Current vs Input Frequency

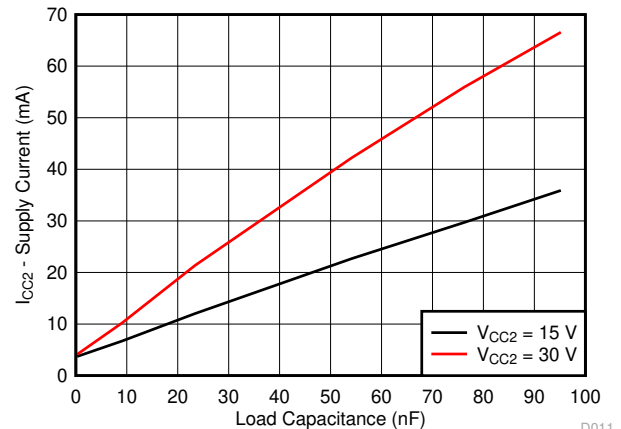

$R_{GH} = 10 \Omega$ $R_{GL} = 5 \Omega, 20 \text{ kHz}$

7-24. I_{CC2} Supply Current vs Load Capacitance

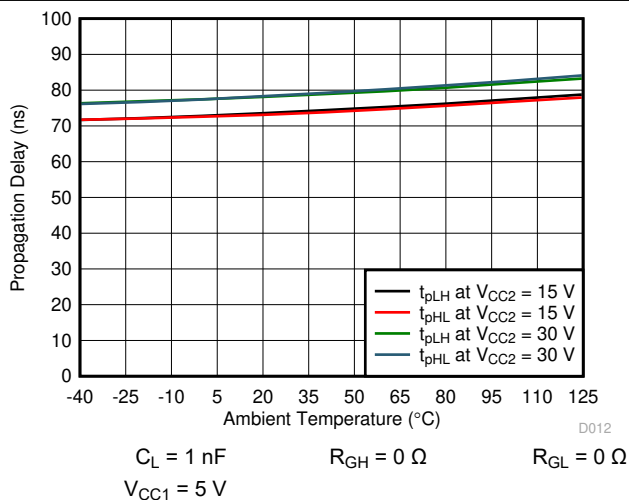

$C_L = 1 \text{ nF}$ $R_{GH} = 0 \Omega$ $R_{GL} = 0 \Omega$
 $V_{CC1} = 5 \text{ V}$

7-25. Propagation Delay vs Temperature

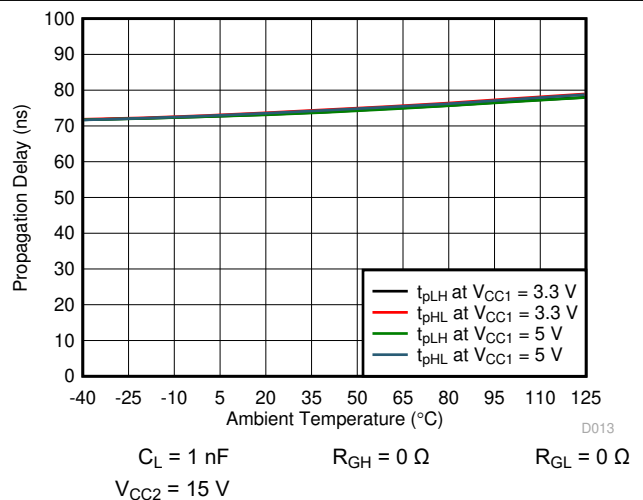

$C_L = 1 \text{ nF}$ $R_{GH} = 0 \Omega$ $R_{GL} = 0 \Omega$
 $V_{CC2} = 15 \text{ V}$

7-26. Propagation Delay vs Temperature

7.12 Typical Characteristics (continued)

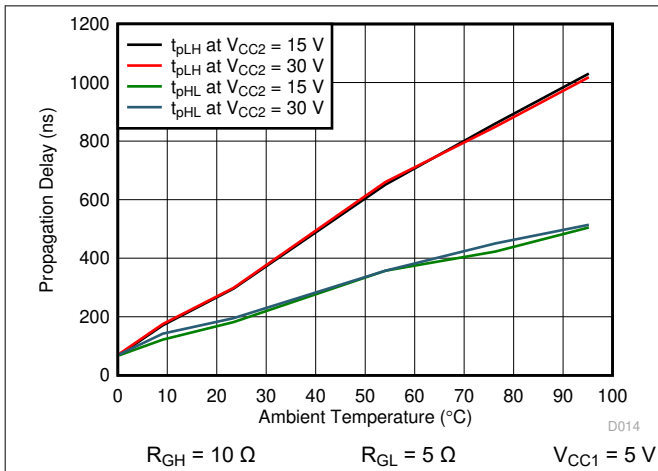

7-27. Propagation Delay vs Load Capacitance

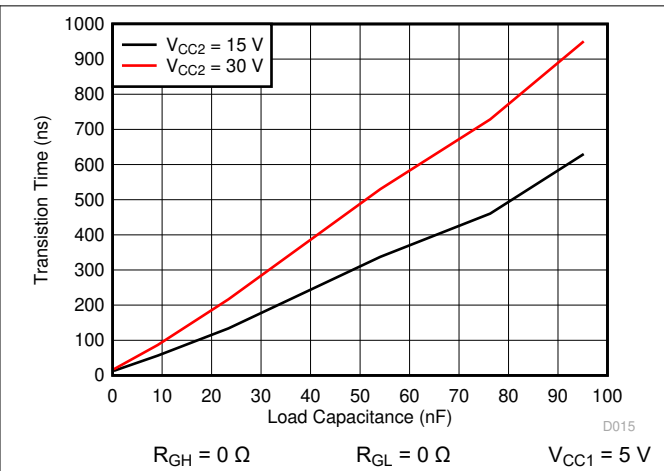

7-28. t_r Rise Time vs Load Capacitance

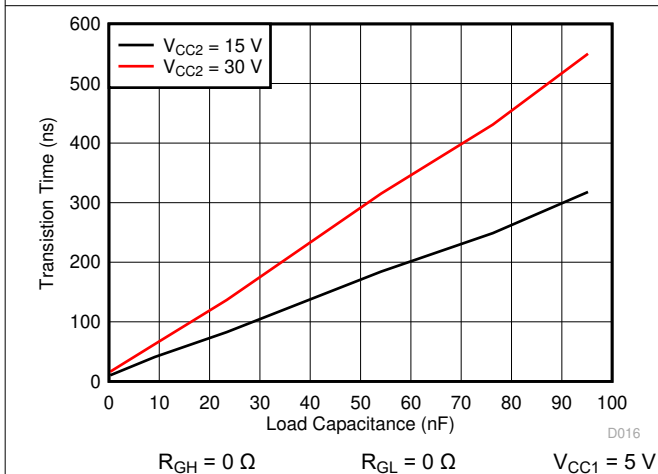

7-29. t_f Fall Time vs Load Capacitance

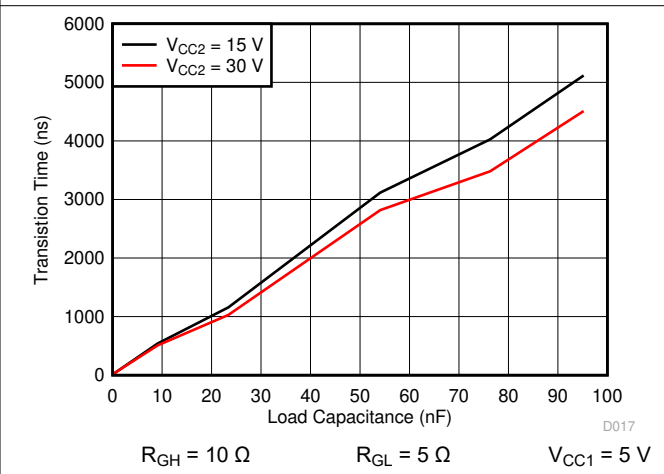

7-30. t_r Rise Time vs Load Capacitance

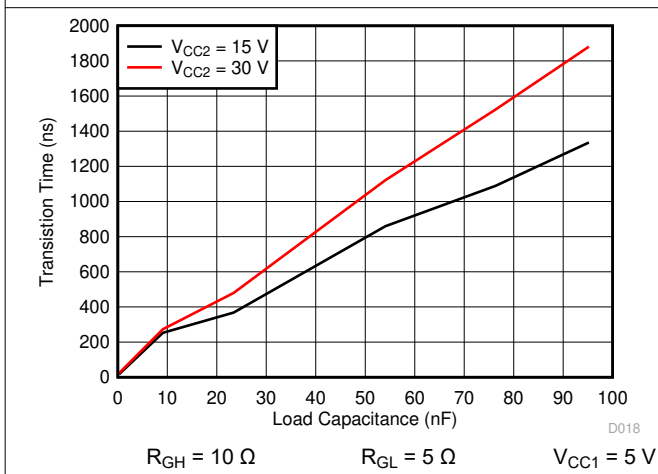

7-31. t_f Fall Time vs Load Capacitance

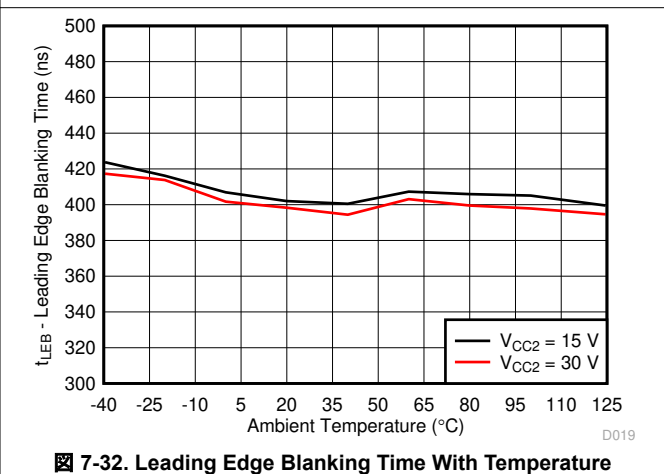

7-32. Leading Edge Blanking Time With Temperature

7.12 Typical Characteristics (continued)

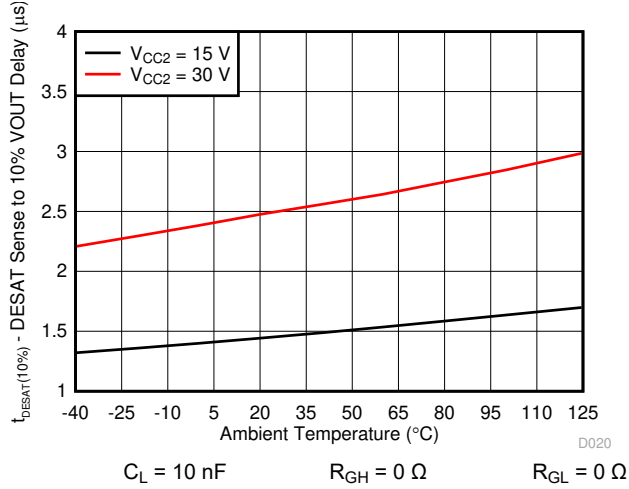

7-33. DESAT Sense to V_{OUT} 10% Delay vs Temperature

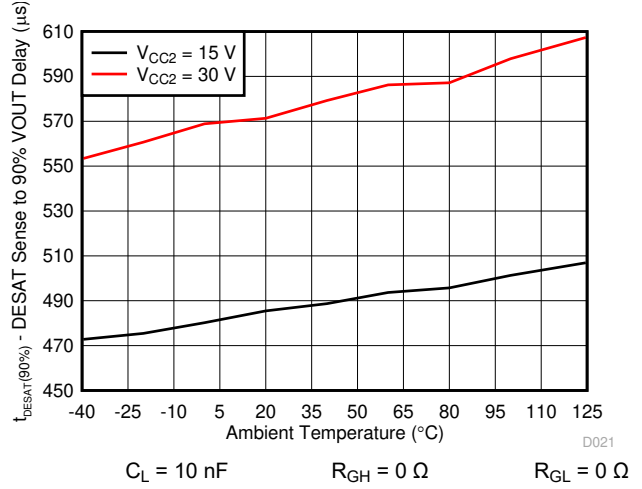

7-34. DESAT Sense to V_{OUT} 90% Delay vs Temperature

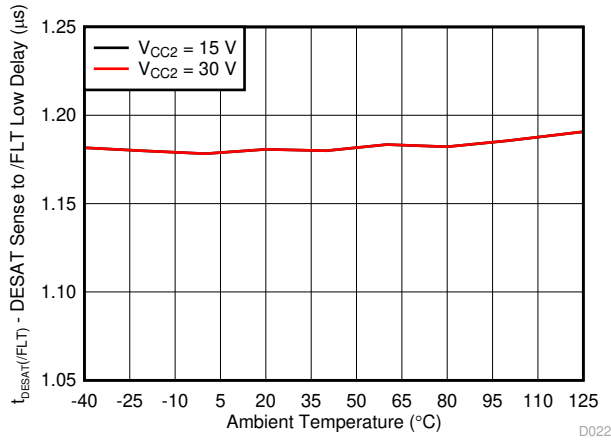

7-35. DESAT Sense to Fault Low Delay vs Temperature

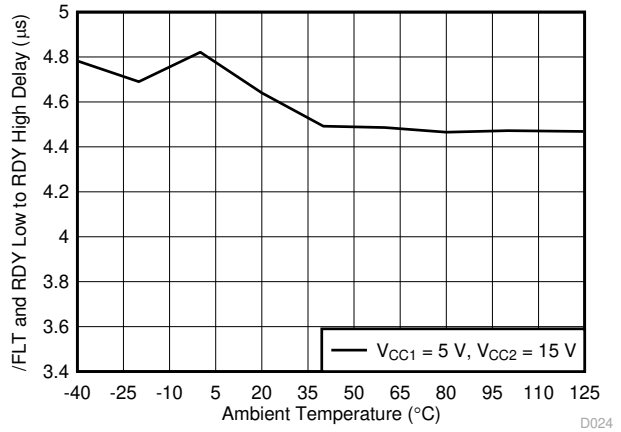

7-36. Fault and RDY Low to RDY High Delay vs Temperature

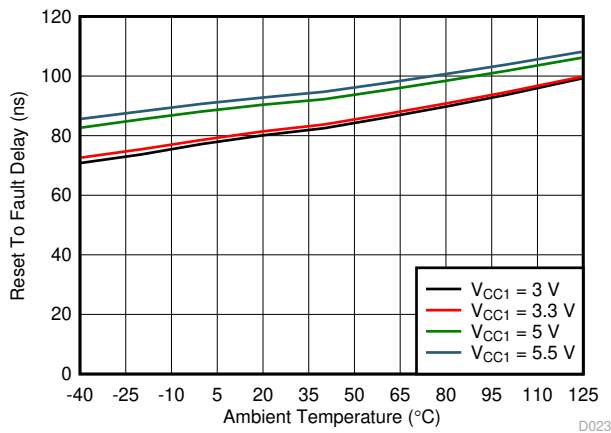

7-37. Reset to Fault Delay Across Temperature

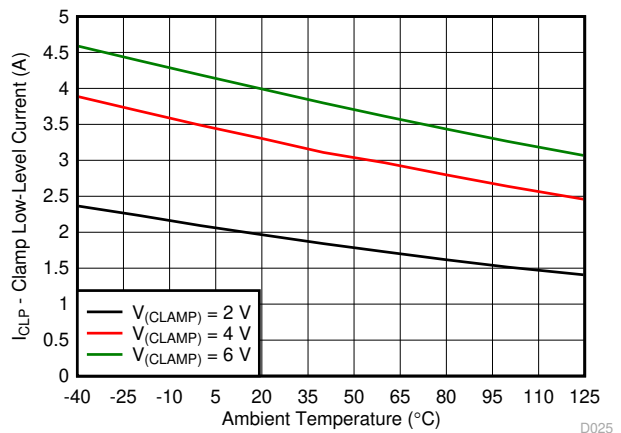

7-38. Miller Clamp Current vs Temperature

7.12 Typical Characteristics (continued)

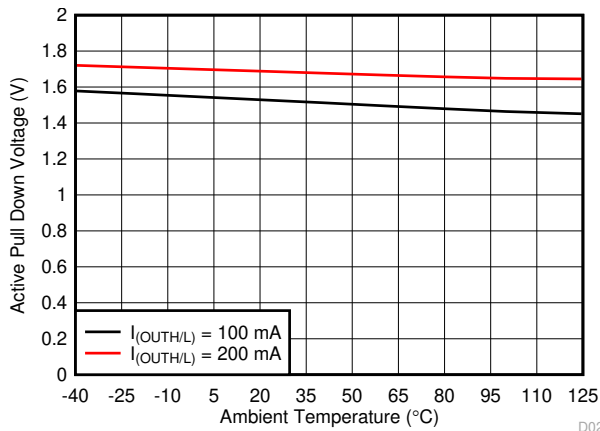

7-39. Active Pulldown Voltage vs Temperature

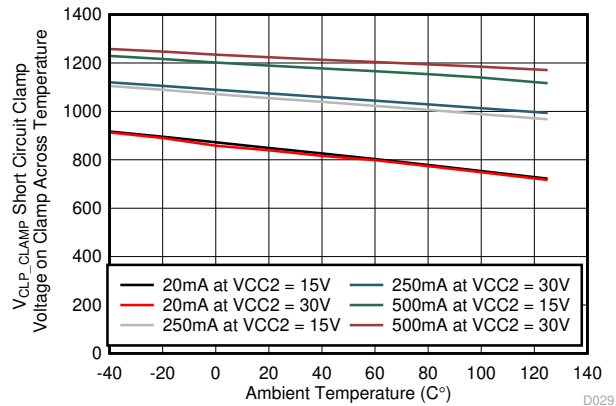

7-40. V_{CLP_CLAMP} - Short-Circuit Clamp Voltage on CLAMP Across Temperature

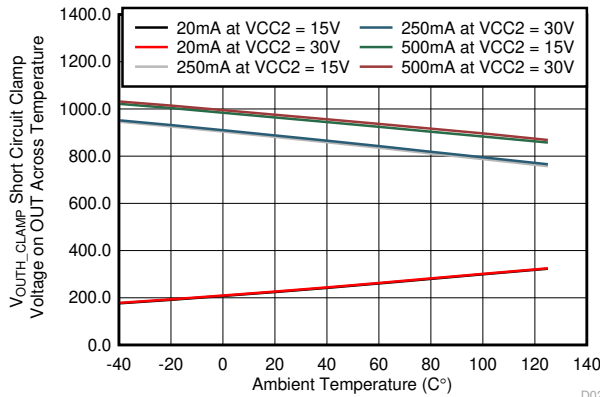

7-41. V_{OUTH_CLAMP} - Short-Circuit Clamp Voltage on OUTH Across Temperature

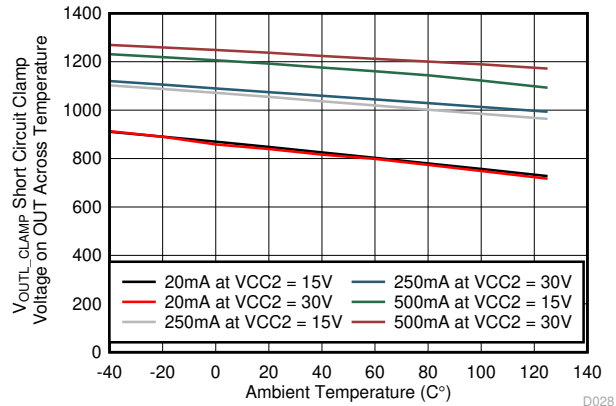

7-42. V_{OUTL_CLAMP} - Short-Circuit Clamp Voltage on OUTL Across Temperature

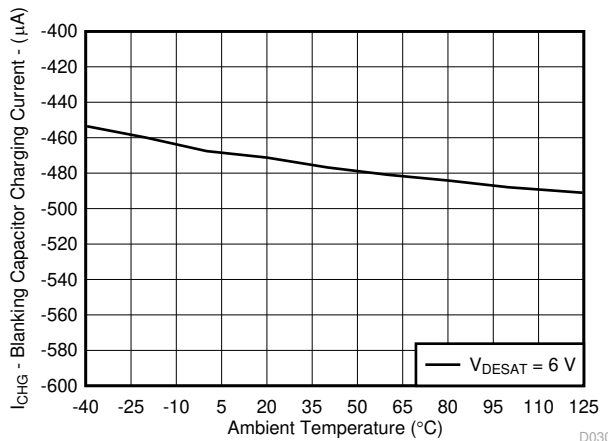

7-43. Blanking Capacitor Charging Current vs Temperature

8 Parameter Measurement Information

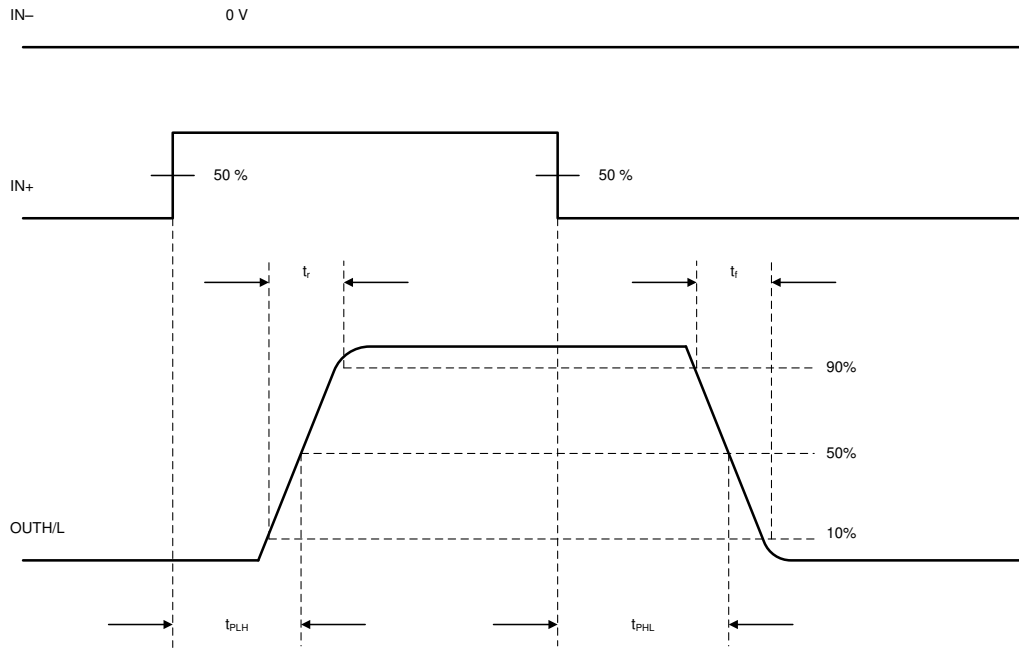

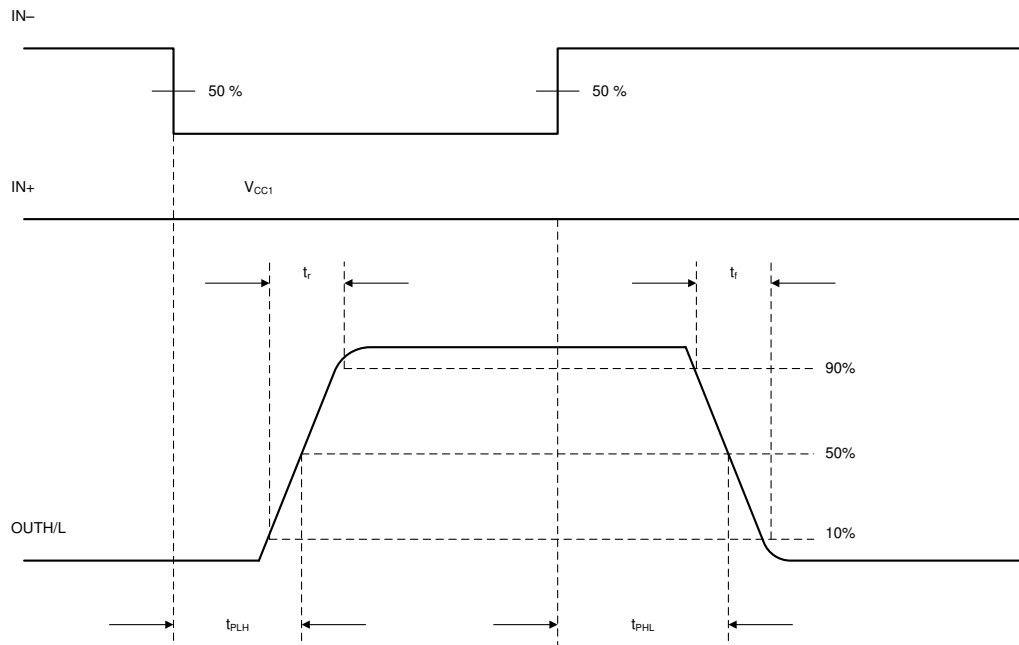

8-1. OUTH and OUTL Propagation Delay, Non-Inverting Configuration

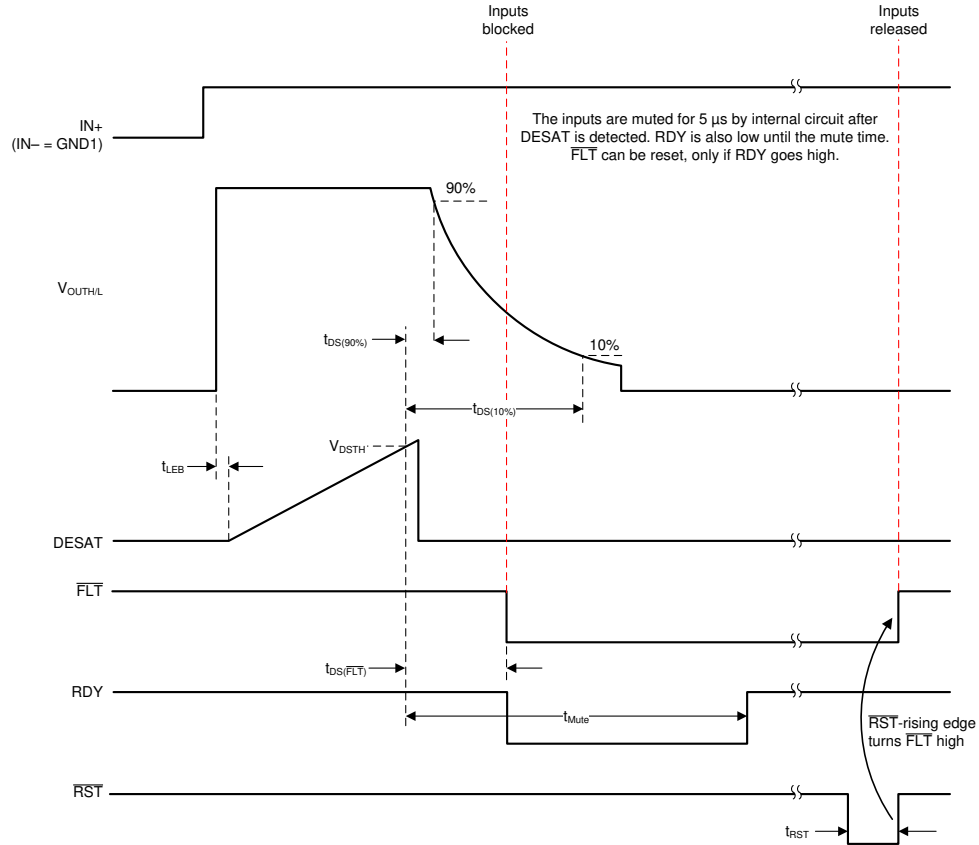

8-2. OUTH and OUTL Propagation Delay, Inverting Configuration

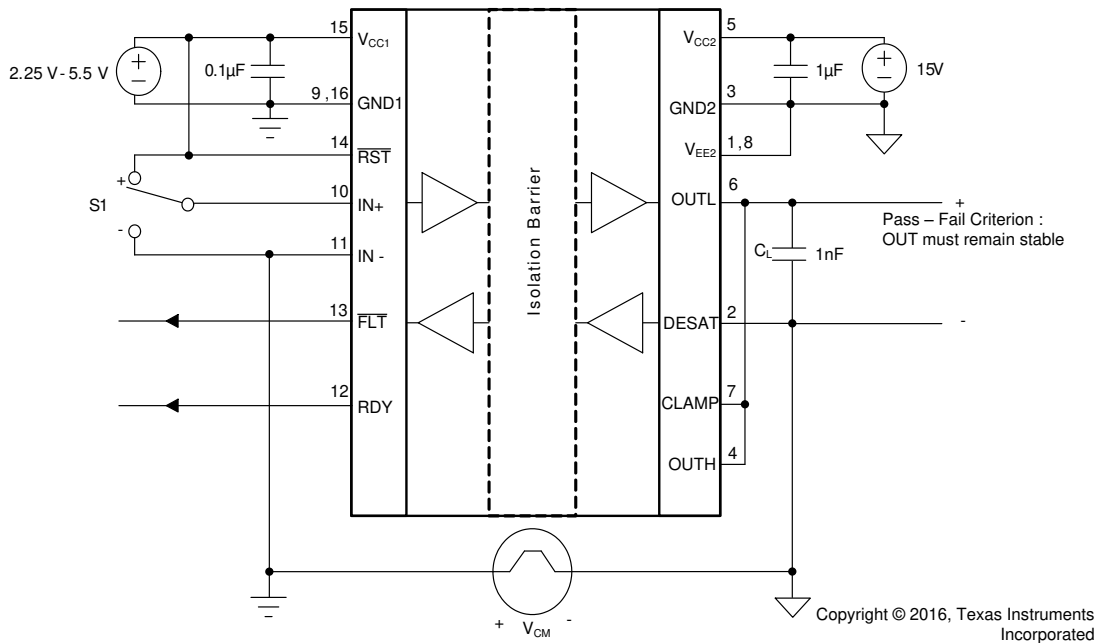

8-3. DESAT, OUTH/L, FLT, RST Delay



8-4. Common-Mode Transient Immunity Test Circuit

9 Detailed Description

9.1 Overview

The ISO5852S is an isolated gate driver for IGBTs and MOSFETs. Input CMOS logic and output power stage are separated by a Silicon dioxide (SiO₂) capacitive isolation.

The IO circuitry on the input side interfaces with a micro controller and consists of gate drive control and RESET ($\overline{\text{RST}}$) inputs, READY (RDY) and FAULT ($\overline{\text{FLT}}$) alarm outputs. The power stage consists of power transistors to supply 2.5-A pullup and 5-A pulldown currents to drive the capacitive load of the external power transistors, as well as DESAT detection circuitry to monitor IGBT collector-emitter overvoltage under short circuit events. The capacitive isolation core consists of transmit circuitry to couple signals across the capacitive isolation barrier, and receive circuitry to convert the resulting low-swing signals into CMOS levels. The ISO5852S also contains under voltage lockout circuitry to prevent insufficient gate drive to the external IGBT, and active output pulldown feature which ensures that the gate-driver output is held low, if the output supply voltage is absent. The ISO5852S also has an active Miller clamp function which can be used to prevent parasitic turn-on of the external power transistor, due to Miller effect, for unipolar supply operation.

9.2 Functional Block Diagram

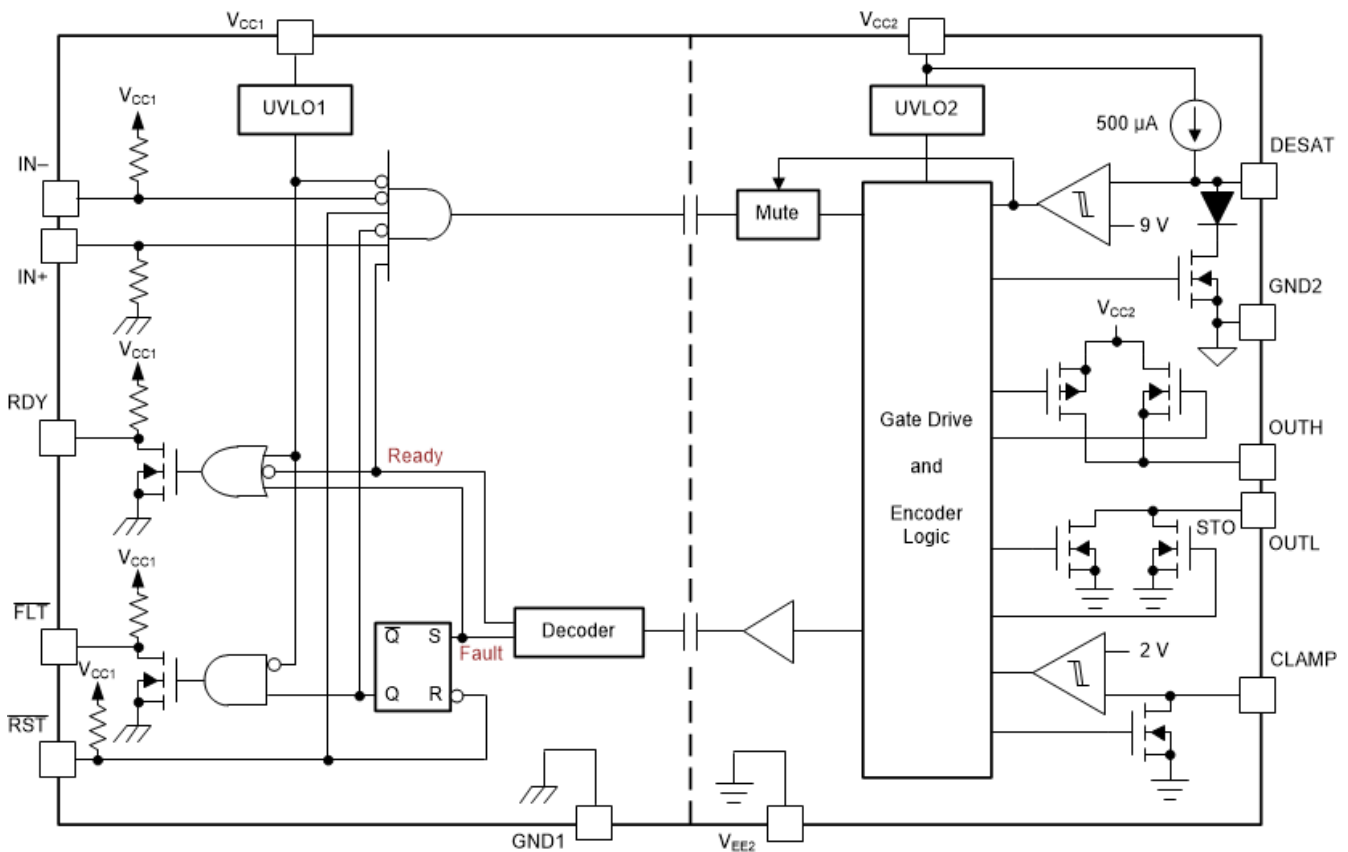

9.3 Feature Description

9.3.1 Supply and Active Miller Clamp

The ISO5852S supports both bipolar and unipolar power supply with active Miller clamp.

For operation with bipolar supplies, the IGBT is turned off with a negative voltage on its gate with respect to its emitter. This prevents the IGBT from unintentionally turning on because of current induced from its collector to its gate due to Miller effect. In this condition it is not necessary to connect CLAMP output of the gate driver to the IGBT gate, but connecting CLAMP output of the gate driver to the IGBT gate is also not an issue. Typical values of V_{CC2} and V_{EE2} for bipolar operation are 15-V and -8-V with respect to GND2.

For operation with unipolar supply, typically, V_{CC2} is connected to 15-V with respect to GND2, and V_{EE2} is connected to GND2. In this use case, the IGBT can turn on due to additional charge from IGBT Miller capacitance caused by a high voltage slew rate transition on the IGBT collector. To prevent IGBT to turn on, the CLAMP pin is connected to IGBT gate and Miller current is sunk through a low impedance CLAMP transistor.

Miller CLAMP is designed for Miller current up to 2-A. When the IGBT is turned-off and the gate voltage transitions below 2-V the CLAMP current output is activated.

9.3.2 Active Output Pulldown

The Active output pulldown feature ensures that the IGBT gate OUTH/L is clamped to V_{EE2} to ensure safe IGBT off-state, when the output side is not connected to the power supply.

9.3.3 Undervoltage Lockout (UVLO) With Ready (RDY) Pin Indication Output

Undervoltage Lockout (UVLO) ensures correct switching of IGBT. The IGBT is turned-off, if the supply V_{CC1} drops below $V_{IT-(UVLO1)}$, irrespective of IN+, IN– and RST input till V_{CC1} goes above $V_{IT+(UVLO1)}$.

In similar manner, the IGBT is turned-off, if the supply V_{CC2} drops below $V_{IT-(UVLO2)}$, irrespective of IN+, IN– and RST input till V_{CC2} goes above $V_{IT+(UVLO2)}$.

Ready (RDY) pin indicates status of input and output side Under Voltage Lock-Out (UVLO) internal protection feature. If either side of device have insufficient supply (V_{CC1} or V_{CC2}), the RDY pin output goes low; otherwise, RDY pin output is high. RDY pin also serves as an indication to the micro-controller that the device is ready for operation.

9.3.4 Soft Turnoff, Fault (\overline{FLT}) and Reset (\overline{RST})

During IGBT overcurrent condition, a mute logic initiates a soft-turn-off procedure which disables, OUTH, and pulls OUTL to low over a time span of 2 μ s. When desaturation is active, a fault signal is sent across the isolation barrier pulling the \overline{FLT} output at the input side low and blocking the isolator input. mute logic is activated through the soft-turn-off period. The \overline{FLT} output condition is latched and can be reset only after RDY goes high, through a active-low pulse at the \overline{RST} input. \overline{RST} has an internal filter to reject noise and glitches. By asserting \overline{RST} for at-least the specified minimum duration (800 ns), device input logic can be enabled or disabled.

9.3.5 Short Circuit Clamp

Under short circuit events it is possible that currents are induced back into the gate-driver OUTH/L and CLAMP pins due to parasitic Miller capacitance between the IGBT collector and gate terminals. Internal protection diodes on OUTH/L and CLAMP help to sink these currents while clamping the voltages on these pins to values slightly higher than the output side supply.

9.4 Device Functional Modes

In ISO5852S OUTH/L to follow IN+ in normal functional mode, $\overline{\text{FLT}}$ pin must be in the high state. 表 9-1 lists the device functions.

表 9-1. Function Table⁽¹⁾

V _{CC1}	V _{CC2}	IN+	IN-	RST	RDY	OUTH/L
PU	PD	X	X	X	Low	Low
PD	PU	X	X	X	Low	Low
PU	PU	X	X	Low	High	Low
PU	Open	X	X	X	Low	Low
PU	PU	Low	X	X	High	Low
PU	PU	X	High	X	High	Low
PU	PU	High	Low	High	High	High

(1) PU: Power Up ($V_{CC1} \geq 2.25\text{ V}$, $V_{CC2} \geq 13\text{ V}$), PD: Power Down ($V_{CC1} \leq 1.7\text{ V}$, $V_{CC2} \leq 9.5\text{ V}$), X: Irrelevant

10 Application and Implementation

注

以下のアプリケーション情報は、TI の製品仕様に含まれるものではなく、TI ではその正確性または完全性を保証いたしません。個々の目的に対する製品の適合性については、お客様の責任で判断していただくこととなります。お客様は自身の設計実装を検証しテストすることで、システムの機能を確認する必要があります。

10.1 Application Information

The ISO5852S device is an isolated gate driver for power semiconductor devices such as IGBTs and MOSFETs. It is intended for use in applications such as motor control, industrial inverters and switched mode power supplies. In these applications, sophisticated PWM control signals are required to turn the power devices on and off, which at the system level eventually may determine, for example, the speed, position, and torque of the motor or the output voltage, frequency and phase of the inverter. These control signals are usually the outputs of a microcontroller, and are at low voltage levels such as 2.5 V, 3.3 V or 5 V. The gate controls required by the MOSFETs and IGBTs, however, are in the range of 30-V (using unipolar output supply) to 15-V (using bipolar output supply), and require high-current capability to drive the large capacitive loads offered by those power transistors. The gate drive must also be applied with reference to the emitter of the IGBT (source for MOSFET), and by construction, the emitter node in a gate-drive system may swing between 0 to the DC-bus voltage, which can be several 100s of volts in magnitude.

The ISO5852S device is therefore used to level shift the incoming 2.5-V, 3.3-V, and 5-V control signals from the microcontroller to the 30-V (using unipolar output supply) to 15-V (using bipolar output supply) drive required by the power transistors while ensuring high-voltage isolation between the driver side and the microcontroller side.

10.2 Typical Applications

☒ [10-1](#) shows the typical application of a three-phase inverter using six ISO5852S isolated gate drivers. Three-phase inverters are used for variable-frequency drives to control the operating speed and torque of AC motors and for high-power applications such as high-voltage DC (HVDC) power transmission.

The basic three-phase inverter consists of six power switches, and each switch is driven by one SO5852S. The switches are driven on and off at high switching frequency with specific patterns that to converter dc bus voltage to three-phase AC voltages.



图 10-1. Typical Motor-Drive Application

10.2.1 Design Requirements

Unlike optocoupler-based gate drivers which required external current drivers and biasing circuitry to provide the input control signals, the input control to the device is CMOS and can be directly driven by the microcontroller. Other design requirements include decoupling capacitors on the input and output supplies, a pullup resistor on the common-drain FLT output signal and RST input signal, and a high-voltage protection diode between the IGBT collector and the DESAT input. Further details are explained in the subsequent sections. 表 10-1 lists the allowed range for input and output supply voltage, and the typical current output available from the gate-driver.

表 10-1. Design Parameters

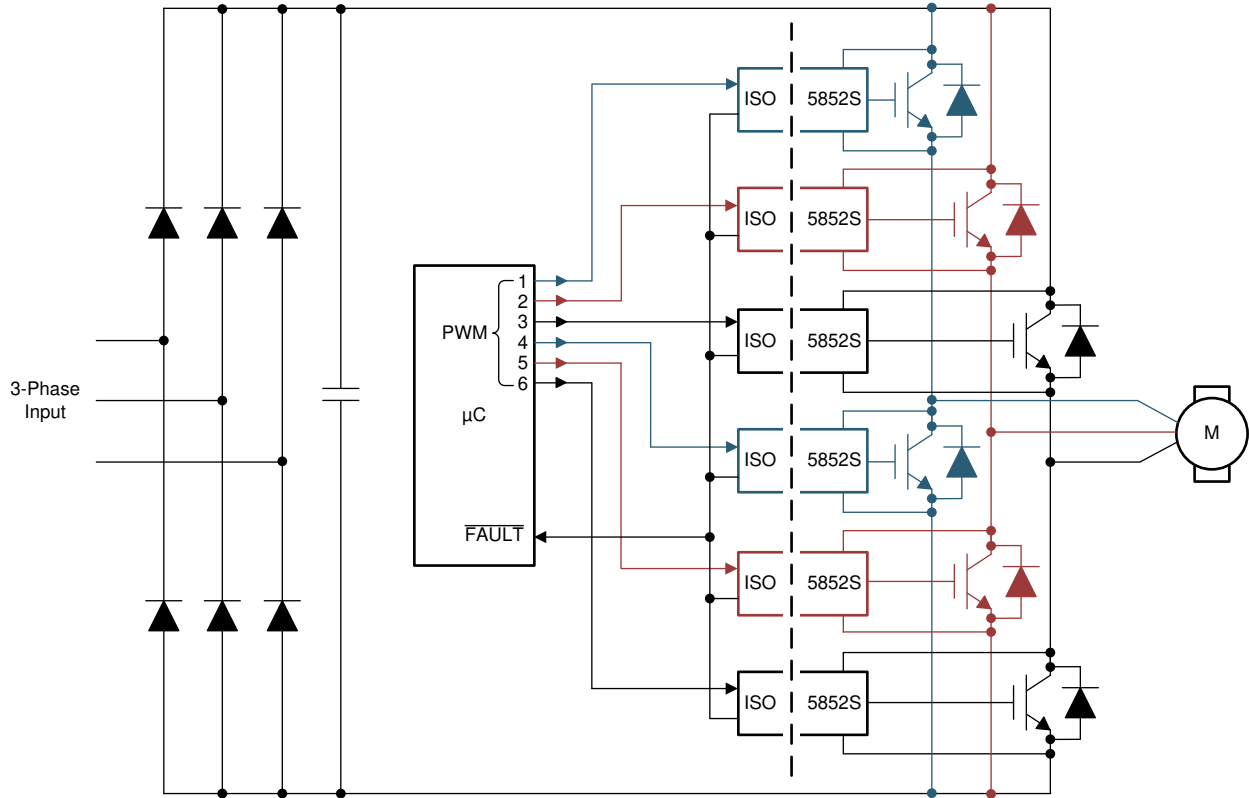
PARAMETER	VALUE
Input supply voltage	2.25 V to 5.5 V
Unipolar output-supply voltage ($V_{CC2} - GND2 = V_{CC2} - V_{EE2}$)	15 V to 30 V
Bipolar output-supply voltage ($V_{CC2} - V_{EE2}$)	15 V to 30 V
Bipolar output-supply voltage ($GND2 - V_{EE2}$)	0 V to 15 V
Output current	2.5 A

10.2.2 Detailed Design Procedure

10.2.2.1 Recommended ISO5852S Application Circuit

The ISO5852S device has both, inverting and noninverting gate-control inputs, an active-low reset input, and an open-drain fault output suitable for wired-OR applications. The recommended application circuit in 图 10-2 shows a typical gate-driver implementation with unipolar output supply. 图 10-3 shows a typical gate-driver implementation with bipolar output supply using the ISO5852S device.

A 0.1- μ F bypass capacitor, recommended at the input supply pin V_{CC1} , and 1- μ F bypass capacitor, recommended at the V_{CC2} output supply pin, provide the large transient currents required during a switching

transition to ensure reliable operation. The 220-pF blanking capacitor disables DESAT detection during the off-to-on transition of the power device. The DESAT diode (D_{DST}) and the 1-k Ω series resistor on the DESAT pin are external protection components. The R_G gate resistor limits the gate-charge current and indirectly controls the rise and fall times of the IGBT collector voltage. The open-drain \overline{FLT} output and RDY output have a passive 10-k Ω pullup resistor. In this application, the IGBT gate driver is disabled when a fault is detected and does not resume switching until the microcontroller applies a reset signal.

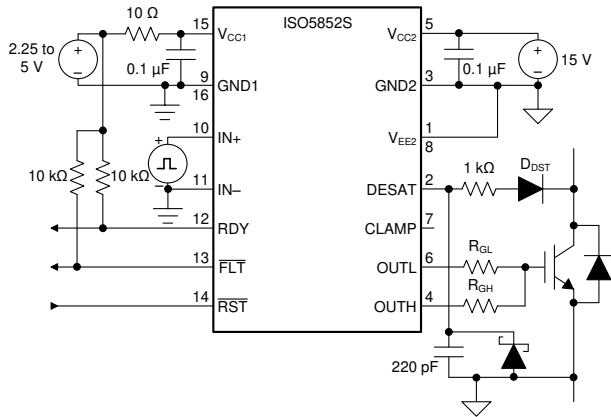

Copyright © 2016, Texas Instruments Incorporated

10-2. Unipolar Output Supply

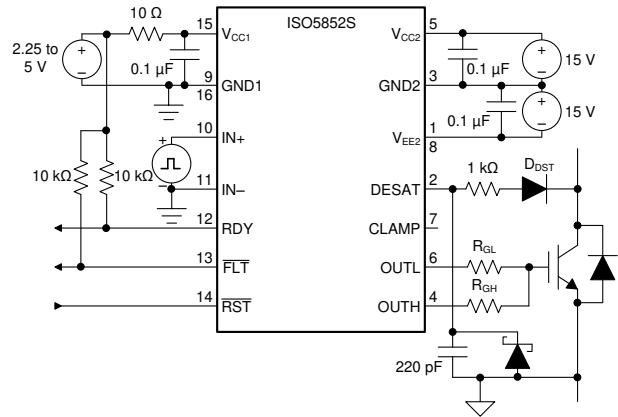

Copyright © 2016, Texas Instruments Incorporated

10-3. Bipolar Output Supply

10.2.2.2 \overline{FLT} and RDY Pin Circuitry

A 50-k Ω pullup resistor exists internally on \overline{FLT} and RDY pins. The \overline{FLT} and RDY pins are an open-drain output. A 10-k Ω pullup resistor can be used to make it faster rise and to provide logic high when \overline{FLT} and RDY is inactive, as shown in 10-4.

Fast common-mode transients can inject noise and glitches on \overline{FLT} and RDY pins because of parasitic coupling. The injection of noise and glitches is dependent on board layout. If required, additional capacitance (100 pF to 300 pF) can be included on the \overline{FLT} and RDY pins.

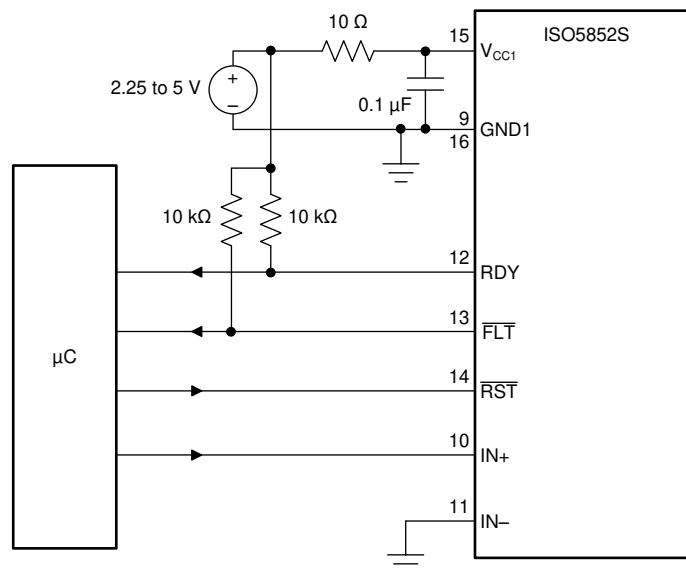

Copyright © 2016, Texas Instruments Incorporated

10-4. \overline{FLT} and RDY Pin Circuitry for High CMTI

10.2.2.3 Driving the Control Inputs

The amount of common-mode transient immunity (CMTI) can be curtailed by the capacitive coupling from the high-voltage output circuit to the low-voltage input side of the ISO5852S device. For maximum CMTI performance, the digital control inputs, IN+ and IN–, must be actively driven by standard CMOS, push-pull drive circuits. This type of low-impedance signal source provides active drive signals that prevent unwanted switching of the ISO5852S output under extreme common-mode transient conditions. Passive drive circuits, such as open-drain configurations using pullup resistors, must be avoided. A 20-ns glitch filter exists that can filter a glitch up to 20 ns on IN+ or IN–.

10.2.2.4 Local Shutdown and Reset

In applications with local shutdown and reset, the $\overline{\text{FLT}}$ output of each gate driver is polled separately, and the individual reset lines are independently asserted low to reset the motor controller after a fault condition.

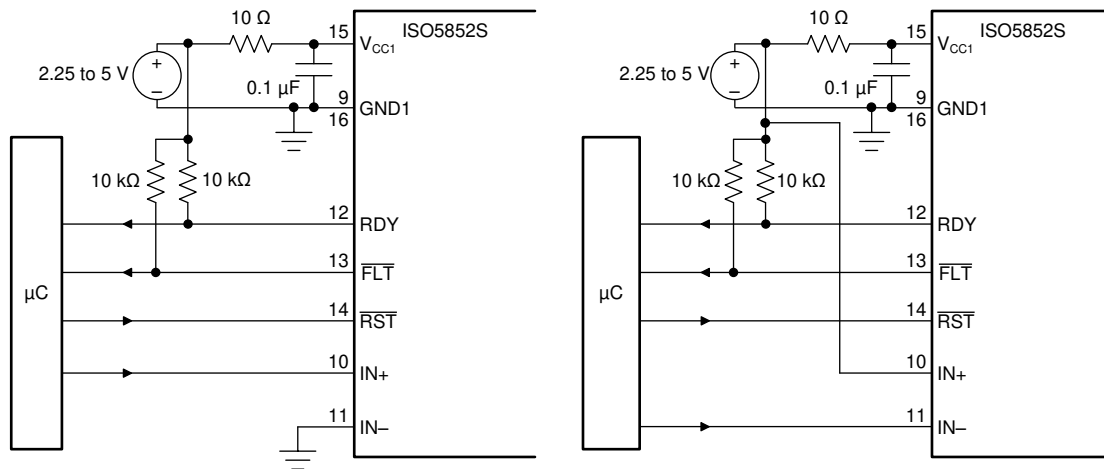

Copyright © 2016, Texas Instruments Incorporated

FIG 10-5. Local Shutdown and Reset for Noninverting (left) and Inverting Input Configuration (right)

10.2.2.5 Global-Shutdown and Reset

When configured for inverting operation, the ISO5852S device can be configured to shutdown automatically in the event of a fault condition by tying the $\overline{\text{FLT}}$ output to IN+. For high reliability drives, the open drain $\overline{\text{FLT}}$ outputs of multiple ISO5852S devices can be wired together forming a single, common fault bus for interfacing directly to the microcontroller. When any of the six gate drivers of a three-phase inverter detects a fault, the active-low $\overline{\text{FLT}}$ output disables all six gate drivers simultaneously.

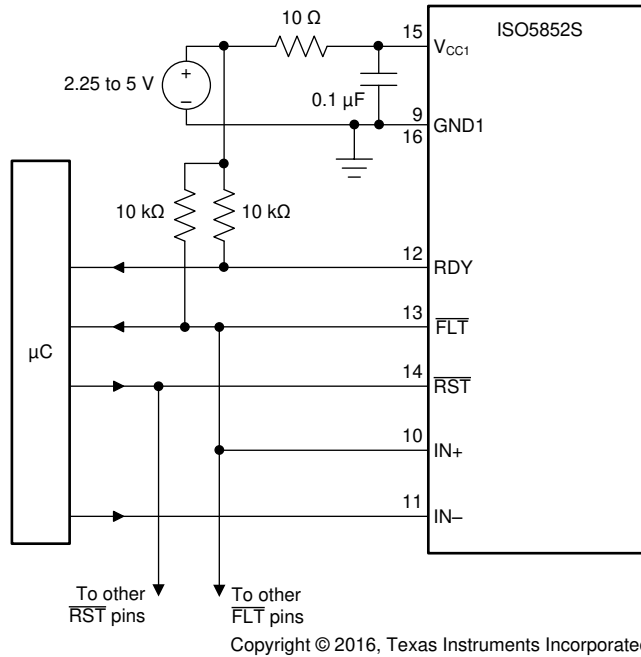

10-6. Global Shutdown With Inverting Input Configuration

10.2.2.6 Auto-Reset

In this case, the gate control signal at IN+ is also applied to the $\overline{\text{RST}}$ input to reset the fault latch every switching cycle. Incorrect $\overline{\text{RST}}$ makes output go low. A fault condition, however, the gate driver remains in the latched fault state until the gate control signal changes to the *gate-low* state and resets the fault latch.

If the gate control signal is a continuous PWM signal, the fault latch is always reset before IN+ goes high again. This configuration protects the IGBT on a cycle-by-cycle basis and automatically resets before the next *on* cycle.

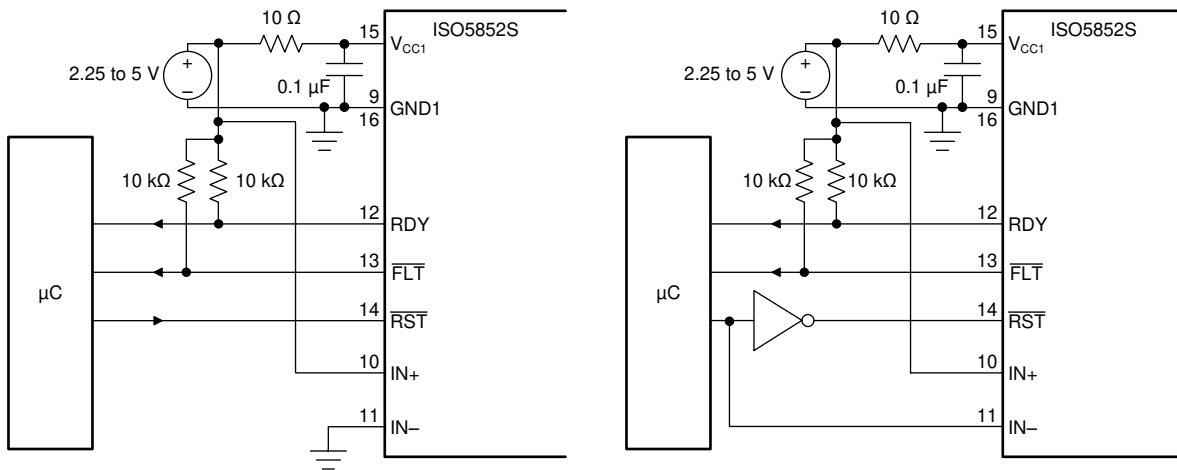

Copyright © 2016, Texas Instruments Incorporated

10-7. Auto Reset for Noninverting and Inverting Input Configuration

10.2.2.7 DESAT Pin Protection

Switching inductive loads causes large, instantaneous forward-voltage transients across the freewheeling diodes of the IGBTs. These transients result in large negative-voltage spikes on the DESAT pin which draw substantial current out of the device. To limit this current below damaging levels, a 100-Ω to 1-kΩ resistor is connected in series with the DESAT diode.

Further protection is possible through an optional Schottky diode, whose low-forward voltage assures clamping of the DESAT input to GND2 potential at low-voltage levels.

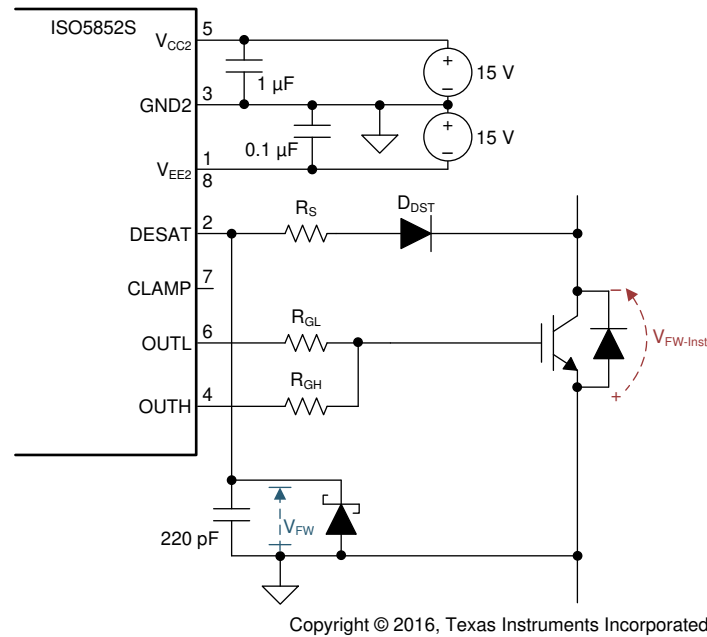

FIG 10-8. DESAT Pin Protection With Series Resistor and Schottky Diode

10.2.2.8 DESAT Diode and DESAT Threshold

The function of the DESAT diode is to conduct forward current, allowing sensing of the saturated collector-to-emitter voltage of the IGBT, $V_{(DESAT)}$, (when the IGBT is *on*), and to block high voltages (when the IGBT is *off*). During the short transition time when the IGBT is switching, a commonly high dV_{CE}/dt voltage ramp rate occurs across the IGBT. This ramp rate results in a charging current $I_{(CHARGE)} = C_{(D-DESAT)} \times dV_{CE}/dt$, charging the blanking capacitor. $C_{(D-DESAT)}$ is the diode capacitance at DESAT.

To minimize this current and avoid false DESAT triggering, fast switching diodes with low capacitance are recommended. As the diode capacitance builds a voltage divider with the blanking capacitor, large collector voltage transients appear at DESAT attenuated by the ratio of $1 + C_{(BLANK)} / C_{(D-DESAT)}$.

Because the sum of the DESAT diode forward-voltage and the IGBT collector-emitter voltage make up the voltage at the DESAT-pin, $V_F + V_{CE} = V_{(DESAT)}$, the V_{CE} level, which triggers a fault condition, can be modified by adding multiple DESAT diodes in series: $V_{CE-FAULT(TH)} = 9V - n \times VF$ (where n is the number of DESAT diodes).

When using two diodes instead of one, diodes with half the required maximum reverse-voltage rating can be selected.

10.2.2.9 Determining the Maximum Available, Dynamic Output Power, P_{OD-max}

The ISO5852S maximum-allowed total power consumption of $P_D = 251$ mW consists of the total input power, P_{ID} , the total output power, P_{OD} , and the output power under load, P_{OL} :

$$P_D = P_{ID} + P_{OD} + P_{OL} \quad (1)$$

With:

$$P_{ID} = V_{CC1-max} \times I_{CC1-max} = 5.5V \times 4.5mA = 24.75mW \quad (2)$$

and:

$$P_{OD} = (V_{CC2} - V_{EE2}) \times I_{CC2-max} = (15V - [-8V]) \times 6mA = 138mW \quad (3)$$

then:

$$P_{OL} = P_D - P_{ID} - P_{OD} = 251 \text{ mW} - 24.75 \text{ mW} - 138 \text{ mW} = 88.25 \text{ mW} \quad (4)$$

In comparison to P_{OL} , the actual dynamic output power under worst case condition, P_{OL-WC} , depends on a variety of parameters:

$$P_{OL-WC} = 0.5 \times f_{INP} \times Q_G \times (V_{CC2} - V_{EE2}) \times \left(\frac{r_{on-max}}{r_{on-max} + R_G} + \frac{r_{off-max}}{r_{off-max} + R_G} \right) \quad (5)$$

where

- f_{INP} = signal frequency at the control input IN+
- Q_G = power device gate charge
- V_{CC2} = positive output supply with respect to GND2
- V_{EE2} = negative output supply with respect to GND2
- r_{on-max} = worst case output resistance in the on-state: 4 Ω
- $r_{off-max}$ = worst case output resistance in the off-state: 2.5 Ω
- R_G = gate resistor

When R_G is determined, 式 5 is to be used to verify whether $P_{OL-WC} < P_{OL}$. 图 10-9 shows a simplified output stage model for calculating P_{OL-WC} .

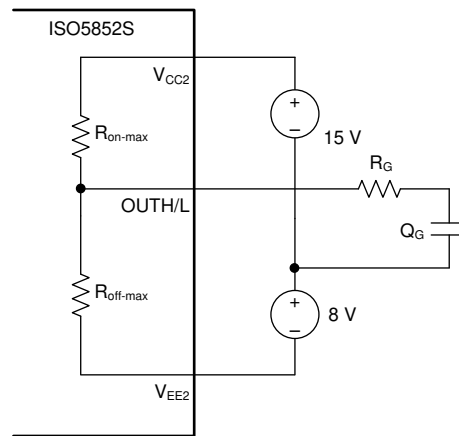

Copyright © 2016, Texas Instruments Incorporated

图 10-9. Simplified Output Model for Calculating P_{OL-WC}

10.2.2.10 Example

This examples considers an IGBT drive with the following parameters:

- $I_{ON-PK} = 2 \text{ A}$
- $Q_G = 650 \text{ nC}$
- $f_{INP} = 20 \text{ kHz}$
- $V_{CC2} = 15 \text{ V}$
- $V_{EE2} = -8 \text{ V}$

Applying the value of the gate resistor $R_G = 10 \Omega$.

Then, calculating the worst-case output-power consumption as a function of R_G , using 式 5 r_{on-max} = worst case output resistance in the on-state: 4 Ω , $r_{off-max}$ = worst case output resistance in the off-state: 2.5 Ω , R_G = gate resistor yields

$$P_{OL-WC} = 0.5 \times 20 \text{ kHz} \times 650 \text{ nC} \times (15 \text{ V} - (-8 \text{ V})) \times \left(\frac{4 \Omega}{4 \Omega + 10 \Omega} + \frac{2.5 \Omega}{2.5 \Omega + 10 \Omega} \right) = 72.61 \text{ mW} \quad (6)$$

Because $P_{OL-WC} = 72.61 \text{ mW}$ is less than the calculated maximum of $P_{OL} = 88.25 \text{ mW}$, the resistor value of $R_G = 10 \Omega$ is suitable for this application.

10.2.2.11 Higher Output Current Using an External Current Buffer

To increase the IGBT gate drive current, a non-inverting current buffer (such as the npn/npn buffer shown in [10-10](#)) can be used. Inverting types are not compatible with the desaturation fault protection circuitry and must be avoided. The MJD44H11/MJD45H11 pair is appropriate for currents up to 8 A, the D44VH10/ D45VH10 pair for up to 15 A maximum.

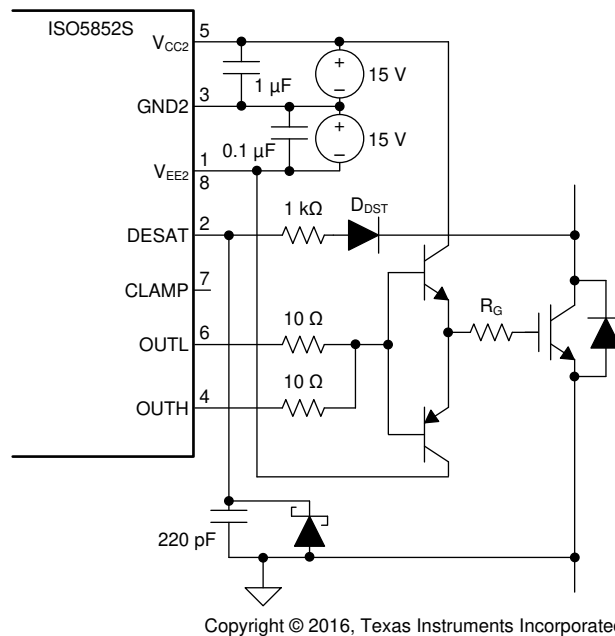

Copyright © 2016, Texas Instruments Incorporated

10-10. Current Buffer for Increased Drive Current

10.2.3 Application Curves

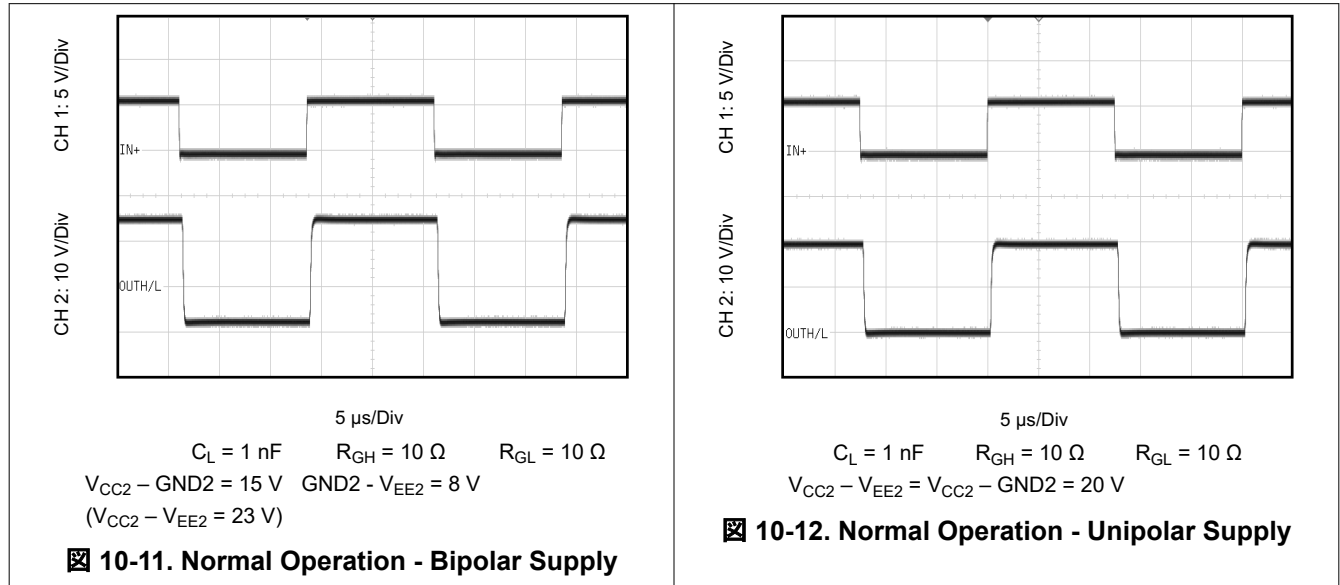

11 Power Supply Recommendations

To help ensure reliable operation at all data rates and supply voltages, a 0.1- μ F bypass capacitor is recommended at the V_{CC1} input supply pin and a 1- μ F bypass capacitor is recommended at the V_{CC2} output supply pin. The capacitors should be placed as close to the supply pins as possible. The recommended placement of the capacitors is 2 mm (maximum) from the input and output power supply pins (V_{CC1} and V_{CC2}).

12 Layout

12.1 Layout Guidelines

minimum of four layers is required to accomplish a low EMI PCB design (see [Figure 12-1](#)). Layer stacking should be in the following order (top-to-bottom): high-speed signal layer, ground plane, power plane and low-frequency signal layer.

- Routing the high-current or sensitive traces on the top layer avoids the use of vias (and the introduction of their inductances) and allows for clean interconnects between the gate driver and the microcontroller and power transistors. Gate driver control input, Gate driver output OUTH/L and DESAT should be routed in the top layer.
- Placing a solid ground plane next to the sensitive signal layer provides an excellent low-inductance path for the return current flow. On the driver side, use GND2 as the ground plane.
- Placing the power plane next to the ground plane creates additional high-frequency bypass capacitance of approximately 100 pF/inch². On the gate-driver V_{EE2} and V_{CC2} can be used as power planes. They can share the same layer on the PCB as long as they are not connected together.
- Routing the slower speed control signals on the bottom layer allows for greater flexibility as these signal links usually have margin to tolerate discontinuities such as vias.

For more detailed layout recommendations, including placement of capacitors, impact of vias, reference planes, routing, and other details, refer to the [Digital Isolator Design Guide](#) (SLLA284).

12.2 Layout Example

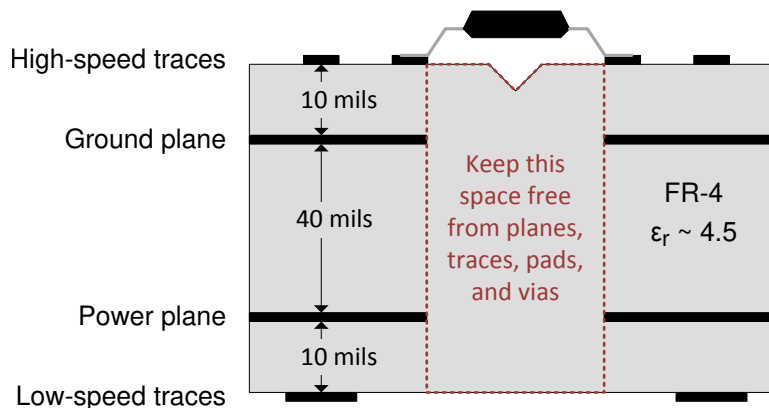

Figure 12-1. Recommended Layer Stack

12.3 PCB Material

For digital circuit boards operating at less than 150 Mbps, (or rise and fall times greater than 1 ns), and trace lengths of up to 10 inches, use standard FR-4 UL94V-0 printed circuit board. This PCB is preferred over cheaper alternatives because of lower dielectric losses at high frequencies, less moisture absorption, greater strength and stiffness, and the self-extinguishing flammability-characteristics.

13 Device and Documentation Support

13.1 Device Support

13.1.1 サード・パーティ製品に関する免責事項

サード・パーティ製品またはサービスに関するテキサス・インスツルメンツの出版物は、単独またはテキサス・インスツルメンツの製品、サービスと一緒に提供される場合に関係なく、サード・パーティ製品またはサービスの適合性に関する是認、サード・パーティ製品またはサービスの是認の表明を意味するものではありません。

13.2 Documentation Support

13.2.1 Related Documentation

For related documentation see the following:

- [Digital Isolator Design Guide](#)
- [ISO5852S Evaluation Module \(EVM\) User's Guide](#)
- [Isolation Glossary](#)

13.3 ドキュメントの更新通知を受け取る方法

ドキュメントの更新についての通知を受け取るには、[ti.com](#) のデバイス製品フォルダを開いてください。「更新の通知を受け取る」をクリックして登録すると、変更されたすべての製品情報に関するダイジェストを毎週受け取れます。変更の詳細については、修正されたドキュメントに含まれている改訂履歴をご覧ください。

13.4 サポート・リソース

[TI E2E™ サポート・フォーラム](#)は、エンジニアが検証済みの回答と設計に関するヒントをエキスパートから迅速かつ直接得ることができる場所です。既存の回答を検索したり、独自の質問をしたりすることで、設計に必要な支援を迅速に得ることができます。

リンクされているコンテンツは、該当する貢献者により、現状のまま提供されるものです。これらは TI の仕様を構成するものではなく、必ずしも TI の見解を反映したものではありません。TI の[使用条件](#)を参照してください。

13.5 Trademarks

TI E2E™ is a trademark of Texas Instruments.

すべての商標は、それぞれの所有者に帰属します。

13.6 静電気放電に関する注意事項



この IC は、ESD によって破損する可能性があります。テキサス・インスツルメンツは、IC を取り扱う際には常に適切な注意を払うことを推奨します。正しい取り扱いおよび設置手順に従わない場合、デバイスを破損するおそれがあります。

ESD による破損は、わずかな性能低下からデバイスの完全な故障まで多岐にわたります。精密な IC の場合、パラメータがわずかに変化するだけで公表されている仕様から外れる可能性があるため、破損が発生しやすくなっています。

13.7 用語集

[テキサス・インスツルメンツ用語集](#) この用語集には、用語や略語の一覧および定義が記載されています。

14 Mechanical, Packaging, and Orderable Information

The following pages include mechanical, packaging, and orderable information. This information is the most current data available for the designated devices. This data is subject to change without notice and revision of this document. For browser-based versions of this data sheet, refer to the left-hand navigation.

PACKAGING INFORMATION

Orderable Device	Status (1)	Package Type	Package Drawing	Pins	Package Qty	Eco Plan (2)	Lead finish/ Ball material (6)	MSL Peak Temp (3)	Op Temp (°C)	Device Marking (4/5)	Samples
ISO5852SDW	OBSOLETE	SOIC	DW	16		TBD	Call TI	Call TI	-40 to 125	ISO5852S	
ISO5852SDWR	ACTIVE	SOIC	DW	16	2000	RoHS & Green	NIPDAU	Level-2-260C-1 YEAR	-40 to 125	ISO5852S	Samples

(1) The marketing status values are defined as follows:

ACTIVE: Product device recommended for new designs.

LIFEBUY: TI has announced that the device will be discontinued, and a lifetime-buy period is in effect.

NRND: Not recommended for new designs. Device is in production to support existing customers, but TI does not recommend using this part in a new design.

PREVIEW: Device has been announced but is not in production. Samples may or may not be available.

OBSOLETE: TI has discontinued the production of the device.

(2) **RoHS:** TI defines "RoHS" to mean semiconductor products that are compliant with the current EU RoHS requirements for all 10 RoHS substances, including the requirement that RoHS substance do not exceed 0.1% by weight in homogeneous materials. Where designed to be soldered at high temperatures, "RoHS" products are suitable for use in specified lead-free processes. TI may reference these types of products as "Pb-Free".

RoHS Exempt: TI defines "RoHS Exempt" to mean products that contain lead but are compliant with EU RoHS pursuant to a specific EU RoHS exemption.

Green: TI defines "Green" to mean the content of Chlorine (Cl) and Bromine (Br) based flame retardants meet JS709B low halogen requirements of <=1000ppm threshold. Antimony trioxide based flame retardants must also meet the <=1000ppm threshold requirement.

(3) MSL, Peak Temp. - The Moisture Sensitivity Level rating according to the JEDEC industry standard classifications, and peak solder temperature.

(4) There may be additional marking, which relates to the logo, the lot trace code information, or the environmental category on the device.

(5) Multiple Device Markings will be inside parentheses. Only one Device Marking contained in parentheses and separated by a "~" will appear on a device. If a line is indented then it is a continuation of the previous line and the two combined represent the entire Device Marking for that device.

(6) Lead finish/Ball material - Orderable Devices may have multiple material finish options. Finish options are separated by a vertical ruled line. Lead finish/Ball material values may wrap to two lines if the finish value exceeds the maximum column width.

Important Information and Disclaimer:The information provided on this page represents TI's knowledge and belief as of the date that it is provided. TI bases its knowledge and belief on information provided by third parties, and makes no representation or warranty as to the accuracy of such information. Efforts are underway to better integrate information from third parties. TI has taken and continues to take reasonable steps to provide representative and accurate information but may not have conducted destructive testing or chemical analysis on incoming materials and chemicals. TI and TI suppliers consider certain information to be proprietary, and thus CAS numbers and other limited information may not be available for release.

In no event shall TI's liability arising out of such information exceed the total purchase price of the TI part(s) at issue in this document sold by TI to Customer on an annual basis.

OTHER QUALIFIED VERSIONS OF ISO5852S :

- Automotive : [ISO5852S-Q1](#)
- Enhanced Product : [ISO5852S-EP](#)

NOTE: Qualified Version Definitions:

- Automotive - Q100 devices qualified for high-reliability automotive applications targeting zero defects
- Enhanced Product - Supports Defense, Aerospace and Medical Applications

GENERIC PACKAGE VIEW

DW 16

SOIC - 2.65 mm max height

7.5 x 10.3, 1.27 mm pitch

SMALL OUTLINE INTEGRATED CIRCUIT

This image is a representation of the package family, actual package may vary.
Refer to the product data sheet for package details.



4224780/A



DW0016B

PACKAGE OUTLINE SOIC - 2.65 mm max height

SOIC



4221009/B 07/2016

NOTES:

1. All linear dimensions are in millimeters. Dimensions in parenthesis are for reference only. Dimensioning and tolerancing per ASME Y14.5M.
2. This drawing is subject to change without notice.
3. This dimension does not include mold flash, protrusions, or gate burrs. Mold flash, protrusions, or gate burrs shall not exceed 0.15 mm, per side.
4. This dimension does not include interlead flash. Interlead flash shall not exceed 0.25 mm, per side.
5. Reference JEDEC registration MS-013.

EXAMPLE BOARD LAYOUT

DW0016B

SOIC - 2.65 mm max height

SOIC



LAND PATTERN EXAMPLE
SCALE:4X



SOLDER MASK DETAILS

4221009/B 07/2016

NOTES: (continued)

- 6. Publication IPC-7351 may have alternate designs.
- 7. Solder mask tolerances between and around signal pads can vary based on board fabrication site.

EXAMPLE STENCIL DESIGN

DW0016B

SOIC - 2.65 mm max height

SOIC



NOTES: (continued)

8. Laser cutting apertures with trapezoidal walls and rounded corners may offer better paste release. IPC-7525 may have alternate design recommendations.
9. Board assembly site may have different recommendations for stencil design.

重要なお知らせと免責事項

テキサス・インスツルメンツは、技術データと信頼性データ(データシートを含みます)、設計リソース(リファレンス デザインを含みます)、アプリケーションや設計に関する各種アドバイス、Web ツール、安全性情報、その他のリソースを、欠陥が存在する可能性のある「現状のまま」提供しており、商品性および特定目的に対する適合性の黙示保証、第三者の知的財産権の非侵害保証を含むいかなる保証も、明示的または黙示的にかかわらず拒否します。

これらのリソースは、テキサス・インスツルメンツ製品を使用する設計の経験を積んだ開発者への提供を意図したものです。(1) お客様のアプリケーションに適したテキサス・インスツルメンツ製品の選定、(2) お客様のアプリケーションの設計、検証、試験、(3) お客様のアプリケーションに該当する各種規格や、その他のあらゆる安全性、セキュリティ、規制、または他の要件への確実な適合に関する責任を、お客様のみが単独で負うものとし、ます。

上記の各種リソースは、予告なく変更される可能性があります。これらのリソースは、リソースで説明されているテキサス・インスツルメンツ製品を使用するアプリケーションの開発の目的でのみ、テキサス・インスツルメンツはその使用をお客様に許諾します。これらのリソースに関して、他の目的で複製することや掲載することは禁止されています。テキサス・インスツルメンツや第三者の知的財産権のライセンスが付与されている訳ではありません。お客様は、これらのリソースを自身で使用した結果発生するあらゆる申し立て、損害、費用、損失、責任について、テキサス・インスツルメンツおよびその代理人を完全に補償するものとし、テキサス・インスツルメンツは一切の責任を拒否します。

テキサス・インスツルメンツの製品は、[テキサス・インスツルメンツの販売条件](#)、または [ti.com](https://www.ti.com) やかかるテキサス・インスツルメンツ製品の関連資料などのいずれかを通じて提供する適用可能な条項の下で提供されています。テキサス・インスツルメンツがこれらのリソースを提供することは、適用されるテキサス・インスツルメンツの保証または他の保証の放棄の拡大や変更を意味するものではありません。

お客様がいかなる追加条項または代替条項を提案した場合でも、テキサス・インスツルメンツはそれらに異議を唱え、拒否します。

郵送先住所：Texas Instruments, Post Office Box 655303, Dallas, Texas 75265
Copyright © 2025, Texas Instruments Incorporated