

## LM137JAN 3-Terminal Adjustable Negative Regulators

Check for Samples: [LM137JAN](#)

### FEATURES

- Output Voltage Adjustable from  $-37V$  to  $-1.2V$
- 1.5A Output Current Specified,  $-55^{\circ}C$  to  $+150^{\circ}C$
- Line Regulation Typically 0.01%/V
- Load Regulation Typically 0.3%
- Excellent Thermal Regulation, 0.002%/W
- 77 dB Ripple Rejection
- Excellent Rejection of Thermal Transients
- 50 ppm/ $^{\circ}C$  Temperature Coefficient
- Temperature-independent Current Limit
- Internal Thermal Overload Protection
- Standard 3-lead Transistor Package
- Output is Short Circuit Protected

### DESCRIPTION

The LM137 are adjustable 3-terminal negative voltage regulators capable of supplying in excess of  $-1.5A$  over an output voltage range of  $-37V$  to  $-1.2V$ . These regulators are exceptionally easy to apply, requiring only 2 external resistors to set the output voltage and 1 output capacitor for frequency compensation. The circuit design has been optimized for excellent regulation and low thermal transients. Further, the LM137 series features internal current limiting, thermal shutdown and safe-area compensation, making them virtually blowout-proof against overloads.

The LM137 serves a wide variety of applications including local on-card regulation, programmable-output voltage regulation or precision current regulation. The LM137 are ideal complements to the LM117 adjustable positive regulators.

### Connection Diagram

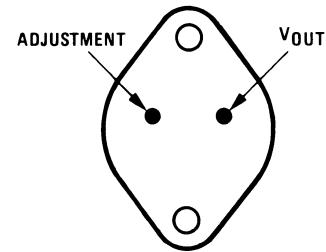

Case Is Input

**Figure 1. TO-3  
Metal Can Package  
Bottom View  
See Package Number K0002C**

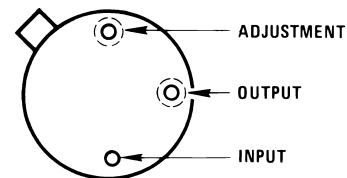

Case Is Input

**Figure 2. TO  
Metal Can Package  
Bottom View  
See Package Number NDT0003A**

**Table 1. LM137 Series Packages and Power Capability**

Device	Package	Rated Power Dissipation	Design Load Current
LM137	TO-3 (K)	20W	1.5A
	TO (NDT)	2W	0.5A



Please be aware that an important notice concerning availability, standard warranty, and use in critical applications of Texas Instruments semiconductor products and disclaimers thereto appears at the end of this data sheet.

All trademarks are the property of their respective owners.

## Typical Applications

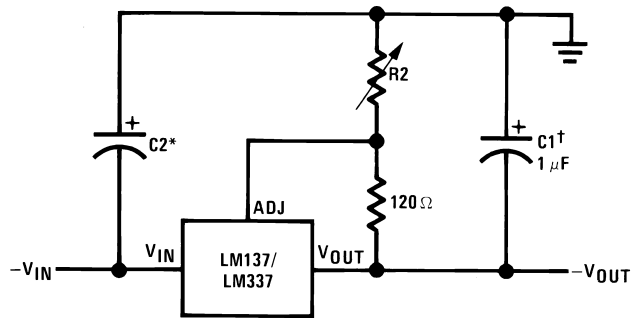

Full output current not available at high input-output voltages

$$-V_{OUT} = -1.25V \left( 1 + \frac{R_2}{120} \right) + (-I_{ADJ} \times R_2)$$

†C1 = 1  $\mu$ F solid tantalum or 10  $\mu$ F aluminum electrolytic required for stability

\*C2 = 1  $\mu$ F solid tantalum is required only if regulator is more than 4" from power-supply filter capacitor

Output capacitors in the range of 1  $\mu$ F to 1000  $\mu$ F of aluminum or tantalum electrolytic are commonly used to provide improved output impedance and rejection of transients

**Figure 3. Adjustable Negative Voltage Regulator**



These devices have limited built-in ESD protection. The leads should be shorted together or the device placed in conductive foam during storage or handling to prevent electrostatic damage to the MOS gates.

### Absolute Maximum Ratings<sup>(1)</sup>

Power Dissipation <sup>(2)</sup>		Internally Limited
Input-Output Voltage Differential		40V
Operating Ambient Temperature Range		$-55^{\circ}\text{C} \leq T_A \leq +125^{\circ}\text{C}$
Operating Junction Temperature Range		$-55^{\circ}\text{C} \leq T_J \leq +150^{\circ}\text{C}$
Maximum Junction Temperature		+150°C
Storage Temperature		$-65^{\circ}\text{C} \leq T_A \leq +150^{\circ}\text{C}$
Lead Temperature (Soldering, 10 sec.)		300°C
Minimum Input Voltage		-41.25V
Maximum Power Dissipation (@25°C)	TO-3	28 Watts
	TO	2.5Watts
Thermal Resistance		
$\theta_{JA}$	TO-3 Metal Can (Still Air)	40°C/W
	TO-3 Metal Can (500LF/Min Air Flow)	14°C/W
	TO Metal Can (Still Air @ 0.5W)	174°C/W
	TO Metal Can (500LF/Min Air Flow @ 0.5W)	64°C/W
$\theta_{JC}$	TO-3	4°C/W
	TO Metal Can (@ 1.0W)	15°C/W
Package Weight (typical)	TO-3	12,750mg
	TO Metal Can	955mg
ESD Rating <sup>(3)</sup>		4K Volts

- (1) Absolute Maximum Ratings indicate limits beyond which damage to the device may occur. Operating Ratings indicate conditions for which the device is functional, but do not ensure specific performance limits. For ensured specifications and test conditions, see the Electrical Characteristics. The ensured specifications apply only for the test conditions listed. Some performance characteristics may degrade when the device is not operated under the listed test conditions.
- (2) The maximum power dissipation must be derated at elevated temperatures and is dictated by  $T_{Jmax}$  (maximum junction temperature),  $\theta_{JA}$  (package junction to ambient thermal resistance), and  $T_A$  (ambient temperature). The maximum allowable power dissipation at any temperature is  $P_{Dmax} = (T_{Jmax} - T_A)/\theta_{JA}$  or the number given in the Absolute Maximum Ratings, whichever is lower.
- (3) Human body model, 100pF discharged through 1.5KΩ

**Table 2. Recommended Operating Conditions**

$T_A$	$-55^{\circ}\text{C} \leq T_A \leq +125^{\circ}\text{C}$
Input Voltage Range	-41.25V to -4.25V

## Quality Conformance Inspection

Mil-Std-883, Method 5005 — Group A

Subgroup	Description	Temp (°C)
1	Static tests at	+25
2	Static tests at	+125
3	Static tests at	-55
4	Dynamic tests at	+25
5	Dynamic tests at	+125
6	Dynamic tests at	-55
7	Functional tests at	+25
8A	Functional tests at	+125
8B	Functional tests at	-55
9	Switching tests at	+25
10	Switching tests at	+125
11	Switching tests at	-55

## LM137H Electrical Characteristics DC Parameters

Symbol	Parameter	Conditions	Notes	Min	Max	Units	Sub-groups
$V_{OUT}$	Output Voltage	$V_{IN} = -4.25V, I_L = 5mA$		-1.275	-1.225	V	1
				-1.3	-1.2	V	2, 3
		$V_{IN} = -4.25V, I_L = 500mA$		-1.275	-1.225	V	1
				-1.3	-1.2	V	2, 3
		$V_{IN} = -41.25V, I_L = 5mA$		-1.275	-1.225	V	1
				-1.3	-1.2	V	2, 3
$V_{IN} = -41.25V, I_L = 50mA$		-1.275	-1.225	V	1		
		-1.3	-1.2	V	2, 3		
$V_{R Line}$	Line Regulation	$V_{IN} = -41.25V$ to $-4.25V, I_L = 5mA$		-9.0	9.0	mV	1
				-23	23	mV	2, 3
$V_{R Load}$	Load Regulation	$V_{IN} = -6.25V, I_L = 5mA$ to $500mA$		-12	12	mV	1
				-24	24	mV	2, 3
		$V_{IN} = -41.25V, I_L = 5mA$ to $50mA$		-6.0	6.0	mV	1
				-12	12	mV	2, 3
$V_{IN} = -6.25V, I_L = 5mA$ to $200mA$		-6.0	6.0	mV	1		
		-12	12	mV	2, 3		
$V_{Rth}$	Thermal Regulation	$V_{IN} = -14.6V, I_L = 500mA$		-5.0	5.0	mV	1
$I_{Adj}$	Adjust Pin Current	$V_{IN} = -4.25V, I_L = 5mA$		25	100	$\mu A$	1, 2, 3
		$V_{IN} = -41.25V, I_L = 5mA$		25	100	$\mu A$	1, 2, 3
$\Delta I_{Adj} / V_{Line}$	Adjust Pin Current Change vs. Line Voltage	$V_{IN} = -41.25V$ to $-4.25V, I_L = 5mA$		-5.0	5.0	$\mu A$	1, 2, 3
$\Delta I_{Adj} / I_{Load}$	Adjust Pin Current Change vs. Load Current	$V_{IN} = -6.25V, I_L = 5mA$ to $500mA$		-5.0	5.0	$\mu A$	1, 2, 3
$I_{OS}$	Output Short Circuit Current	$V_{IN} = -4.25V$		0.5	1.8	A	1, 2, 3
		$V_{IN} = -40V$		0.05	0.5	A	1, 2, 3
$V_{OUT Recovery}$	Output Voltage Recovery After Output Short Circuit Current	$V_{IN} = -4.25V$		-1.275	-1.225	V	1
				-1.3	-1.2	V	2, 3
		$V_{IN} = -40V$		-1.275	-1.225	V	1
				-1.3	-1.2	V	2, 3

**LM137H Electrical Characteristics DC Parameters (continued)**

Symbol	Parameter	Conditions	Notes	Min	Max	Units	Sub-groups
I <sub>Q</sub>	Minimum Load Current	V <sub>IN</sub> = -4.25V		0.2	3.0	mA	1, 2, 3
		V <sub>IN</sub> = -14.25V		0.2	3.0	mA	1, 2, 3
		V <sub>IN</sub> = -41.25V		1.0	5.0	mA	1, 2, 3
V <sub>Start</sub>	Voltage Start-up	V <sub>IN</sub> = -4.25V, I <sub>L</sub> = 500mA		-1.275	-1.225	V	1
				-1.3	-1.2	V	2, 3
V <sub>OUT</sub>	Output Voltage	V <sub>IN</sub> = -6.25V, I <sub>L</sub> = 5mA (No Subgroup)	(1)	-1.3	-1.2	V	

(1) Tested at +125°C ; correlated to +150°C

**LM137H Electrical Characteristics A Parameters**

Symbol	Parameter	Conditions	Notes	Min	Max	Units	Sub-groups
$\frac{\Delta V_{IN}}{\Delta V_{OUT}}$	Ripple Rejection	V <sub>IN</sub> = -6.25V, I <sub>L</sub> = 125mA, e <sub>1</sub> = 1V <sub>RMS</sub> at 2400Hz		48		dB	4
V <sub>NO</sub>	Output Noise Voltage	V <sub>IN</sub> = -6.25V, I <sub>L</sub> = 50mA			120	μV <sub>RMS</sub>	
$\frac{\Delta V_{OUT}}{\Delta V_{IN}}$	Line Transient Response	V <sub>IN</sub> = -6.25V, V <sub>Pulse</sub> = -1V, I <sub>L</sub> = 50mA			80	mV/V	7
$\frac{\Delta V_{OUT}}{\Delta I_L}$	Load Transient Response	V <sub>IN</sub> = -6.25V, I <sub>L</sub> = 50mA, ΔI <sub>L</sub> = 200mA	(1)		60	mV	7

(1) Slash sheet limit of 0.3mV/mA is equivalent to 60mV

## LM137H Electrical Characteristics DC Parameters: Drift Values

Delta calculations performed on JAN S devices at group B, subgroup 5 only.

Symbol	Parameter	Conditions	Notes	Min	Max	Units	Sub-groups
V <sub>OUT</sub>	Output Voltage	V <sub>IN</sub> = -4.25V, I <sub>L</sub> = 5mA		-0.01	0.01	V	1
		V <sub>IN</sub> = -4.25V, I <sub>L</sub> = 500mA		-0.01	0.01	V	1
		V <sub>IN</sub> = -41.25V, I <sub>L</sub> = 5mA		-0.01	0.01	V	1
		V <sub>IN</sub> = -41.25V, I <sub>L</sub> = 50mA		-0.01	0.01	V	1
V <sub>R Line</sub>	Line Regulation	V <sub>IN</sub> = 41.25V to -4.25V, I <sub>L</sub> = 5mA		-4.0	4.0	mV	1
I <sub>Adj</sub>	Adjust Pin Current	V <sub>IN</sub> = -4.25V, I <sub>L</sub> = 5mA		-10	10	μA	1
		V <sub>IN</sub> = -41.25V, I <sub>L</sub> = 5mA		-10	10	μA	1

## LM137K Electrical Characteristics DC Parameters

Symbol	Parameter	Conditions	Notes	Min	Max	Units	Sub-groups
V <sub>OUT</sub>	Output Voltage	V <sub>IN</sub> = -4.25V, I <sub>L</sub> = 5mA		-1.275	-1.225	V	1
				-1.3	-1.2	V	2, 3
		V <sub>IN</sub> = -4.25V, I <sub>L</sub> = 1.5A		-1.275	-1.225	V	1
				-1.3	-1.2	V	2, 3
		V <sub>IN</sub> = -41.25V, I <sub>L</sub> = 5mA		-1.275	-1.225	V	1
				-1.3	-1.2	V	2, 3
V <sub>R Line</sub>	Line Regulation	-41.25V ≤ V <sub>IN</sub> ≤ -4.25V, I <sub>L</sub> = 5mA		-9.0	9.0	mV	1
				-23	23	mV	2, 3
V <sub>R Load</sub>	Load Regulation	V <sub>IN</sub> = -6.25V, I <sub>L</sub> = 5mA to 1.5A		-6.0	6.0	mV	1
				-12	12	mV	2, 3
		V <sub>IN</sub> = -41.25V, I <sub>L</sub> = 5mA to 200mA		-6.0	6.0	mV	1
				-12	12	mV	2, 3
V <sub>Rth</sub>	Thermal Regulation	V <sub>IN</sub> = -14.6V, I <sub>L</sub> = 1.5A		-5.0	5.0	mV	1
I <sub>Adj</sub>	Adjust Pin Current	V <sub>IN</sub> = -4.25V, I <sub>L</sub> = 5mA		25	100	μA	1, 2, 3
		V <sub>IN</sub> = -41.25V, I <sub>L</sub> = 5mA		25	100	μA	1, 2, 3
ΔI <sub>Adj</sub> / V <sub>Line</sub>	Adjust Pin Current Change vs. Line Voltage	-41.25V ≤ V <sub>IN</sub> ≤ -4.25V, I <sub>L</sub> = 5mA		-5.0	5.0	μA	1, 2, 3
ΔI <sub>Adj</sub> / I <sub>Load</sub>	Adjust Pin Current Change vs. Load Current	V <sub>IN</sub> = -6.25V, I <sub>L</sub> = 5mA to 1.5A		-5.0	5.0	μA	1, 2, 3
I <sub>OS</sub>	Output Short Circuit Current	V <sub>IN</sub> = -4.25V		1.5	3.5	A	1, 2, 3
		V <sub>IN</sub> = -40V		0.2	1.0	A	1, 2, 3
V <sub>OUT Recovery</sub>	Output Voltage Recovery	V <sub>IN</sub> = -4.25V		-1.275	-1.225	V	1
				-1.3	-1.2	V	2, 3
		V <sub>IN</sub> = -40V		-1.275	-1.225	V	1
				-1.3	-1.2	V	2, 3
I <sub>Q</sub>	Minimum Load Current	V <sub>IN</sub> = -4.25V		0.2	3.0	mA	1, 2, 3
		V <sub>IN</sub> = -14.25V		0.2	3.0	mA	1, 2, 3
		V <sub>IN</sub> = -41.25V		1.0	5.0	mA	1, 2, 3
V <sub>Start</sub>	Voltage Start-up	V <sub>IN</sub> = 4.25V, I <sub>L</sub> = 1.5A		-1.275	-1.225	V	1
		V <sub>IN</sub> = 4.25V, I <sub>L</sub> = 1.5A		-1.3	-1.2	V	2, 3
V <sub>OUT</sub>	Output Voltage	V <sub>IN</sub> = -6.25V, I <sub>L</sub> = 5mA No Subgroup	(1)	-1.3	-1.2	V	

(1) Tested at +125°C ; correlated to +150°C

**LM137K Electrical Characteristics AC Parameters**

Symbol	Parameter	Conditions	Notes	Min	Max	Units	Sub-groups
$\Delta V_{IN} / \Delta V_{OUT}$	Ripple Rejection	$V_{IN} = -6.25V, I_L = 500mA, e_1 = 1V_{RMS}$ at 2400Hz		50		dB	4
$V_{NO}$	Output Noise Voltage	$V_{IN} = -6.25V, I_L = 100mA$			120	$\mu V_{RMS}$	
$\Delta V_{OUT} / \Delta V_{IN}$	Line Transient Response	$V_{IN} = -6.25V, I_L = 100mA, V_{Pulse} = -1V$			80	mV/V	7
$\Delta V_{OUT} / \Delta I_L$	Load Transient Response	$V_{IN} = -6.25V, I_L = 100mA, \Delta I_L = 400mA$	(1)		60	mV	7

(1) Slash sheet limit of 0.15mV/mA is equivalent to 60mV

**LM137K Electrical Characteristics DC Parameters: Drift Values**

Delta calculations performed on JAN S devices at group B, subgroup 5 only.

Symbol	Parameter	Conditions	Notes	Min	Max	Units	Sub-groups
$V_{OUT}$	Output Voltage	$V_{IN} = -4.25V, I_L = 5mA$		-0.01	0.01	V	1
$V_{R\ line}$	Line Regulation	$V_{IN} = -41.25V$ to $-4.25, I_L = 5mA$		-4.0	4.0	mV	1
$I_{Adj}$	Adjust Pin Current	$V_{IN} = -41.25V, I_L = 5mA$		-10	10	$\mu A$	1

**Schematic Diagram**

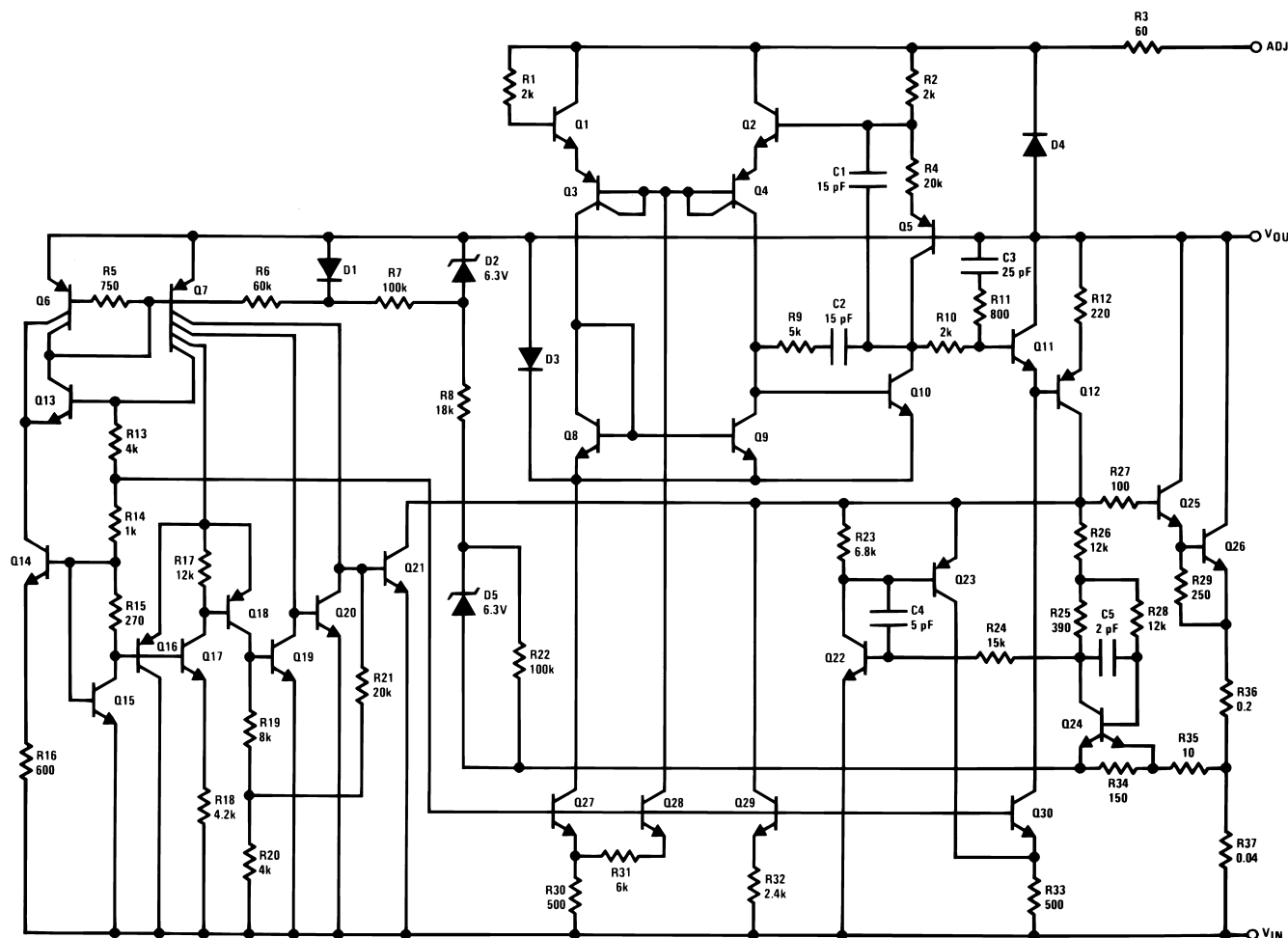

## Thermal Regulation

When power is dissipated in an IC, a temperature gradient occurs across the IC chip affecting the individual IC circuit components. With an IC regulator, this gradient can be especially severe since power dissipation is large. Thermal regulation is the effect of these temperature gradients on output voltage (in percentage output change) per Watt of power change in a specified time. Thermal regulation error is independent of electrical regulation or temperature coefficient, and occurs within 5 ms to 50 ms after a change in power dissipation. Thermal regulation depends on IC layout as well as electrical design. The thermal regulation of a voltage regulator is defined as the percentage change of  $V_{OUT}$ , per Watt, within the first 10 ms after a step of power is applied. The LM137's specification is 0.02%/W, max.

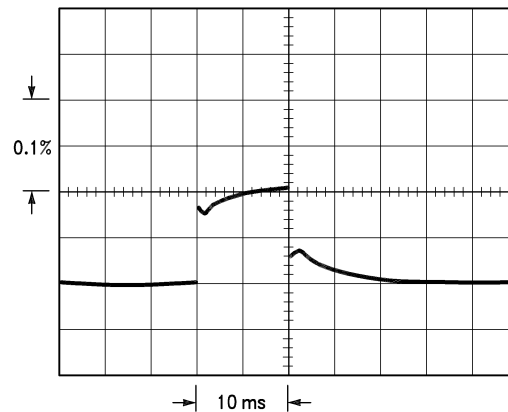

LM137,  $V_{OUT} = -10V$   
 $V_{IN} - V_{OUT} = -40V$   
 $I_{IL} = 0A \rightarrow 0.25A \rightarrow 0A$   
 Vertical sensitivity, 5 mV/div

**Figure 4.**

In [Figure 4](#), a typical LM137's output drifts only 3 mV (or 0.03% of  $V_{OUT} = -10V$ ) when a 10W pulse is applied for 10 ms. This performance is thus well inside the specification limit of  $0.02\%/W \times 10W = 0.2\%$  max. When the 10W pulse is ended, the thermal regulation again shows a 3 mV step as the LM137 chip cools off. Note that the load regulation error of about 8 mV (0.08%) is additional to the thermal regulation error. In [Figure 5](#), when the 10W pulse is applied for 100 ms, the output drifts only slightly beyond the drift in the first 10 ms, and the thermal error stays well within 0.1% (10 mV).

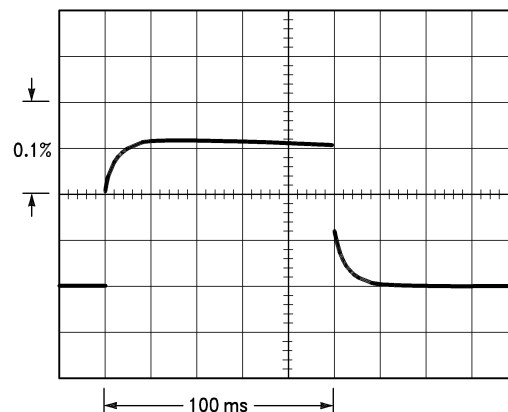

LM137,  $V_{OUT} = -10V$   
 $V_{IN} - V_{OUT} = -40V$   
 $I_L = 0A \rightarrow 0.25A \rightarrow 0A$   
 Horizontal sensitivity, 20 ms/div

**Figure 5.**



Typical Applications

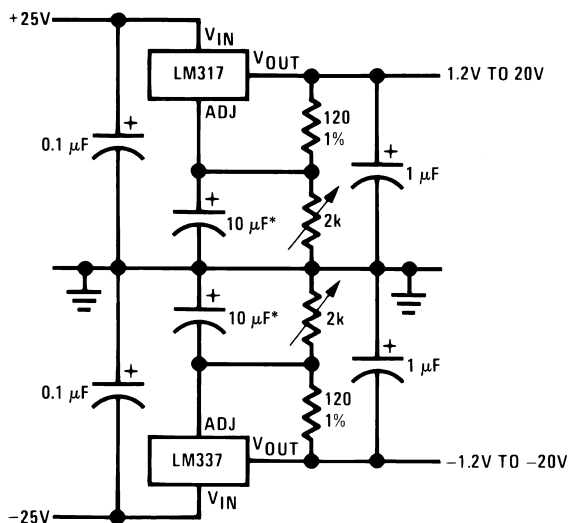

Full output current not available at high input-output voltages  
 \*The 10 μF capacitors are optional to improve ripple rejection

Figure 6. Adjustable Lab Voltage Regulator

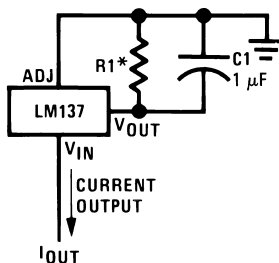

$$I_{OUT} = \frac{1.250V}{R1}$$

\*0.8Ω ≤ R1 ≤ 120Ω

Figure 7. Current Regulator

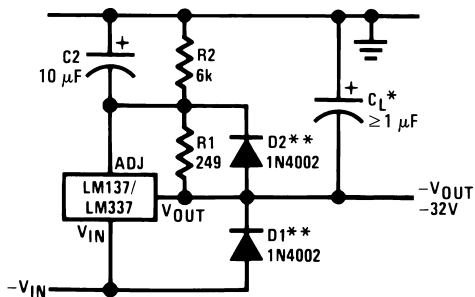

\*When CL is larger than 20 μF, D1 protects the LM137 in case the input supply is shorted  
 \*\*When C2 is larger than 10 μF and -VOUT is larger than -25V, D2 protects the LM137 in case the output is shorted

Figure 8. Negative Regulator with Protection Diodes

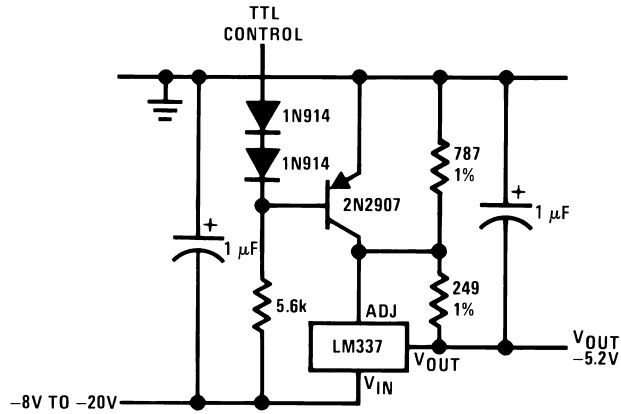

\*Minimum output  $\approx -1.3V$  when control input is low

Figure 9. -5.2V Regulator with Electronic Shutdown\*

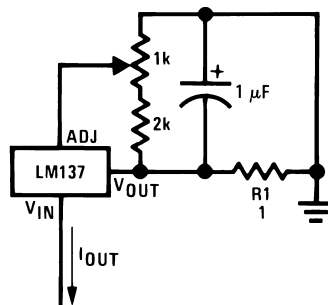

$$I_{OUT} = \left( \frac{1.5V}{R1} \right) \pm 15\% \text{ adjustable}$$

Figure 10. Adjustable Current Regulator

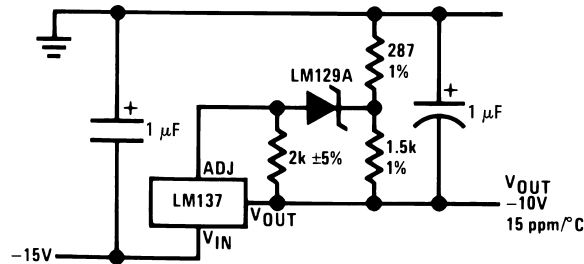

Figure 11. High Stability -10V Regulator

### Typical Performance Characteristics

(H & K Packages)

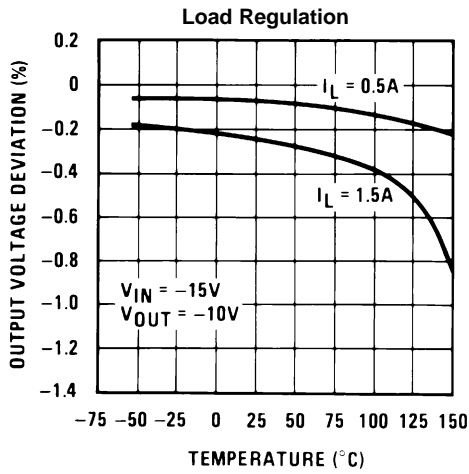

Figure 12.

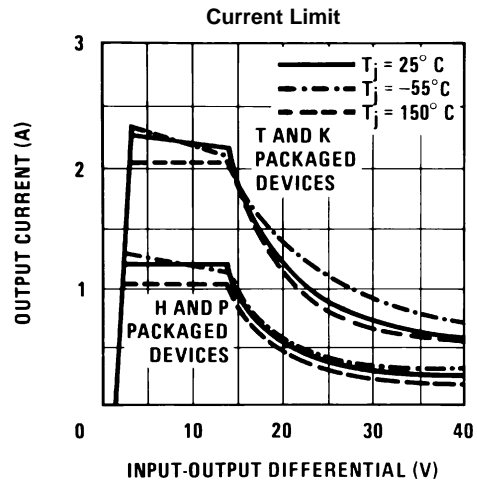

Figure 13.

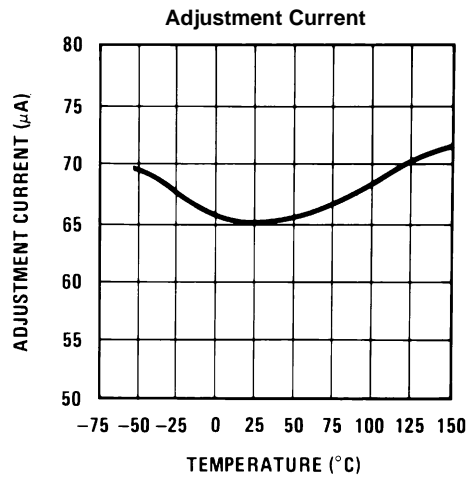

Figure 14.

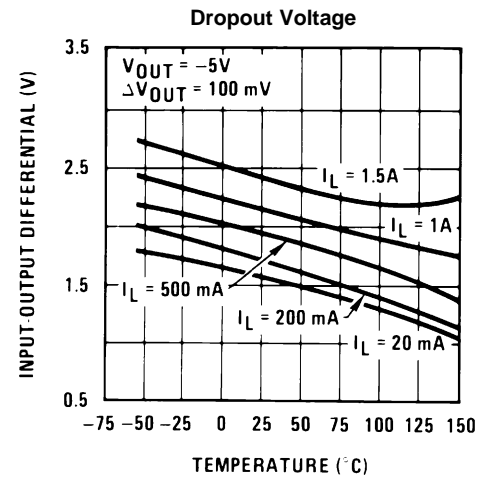

Figure 15.

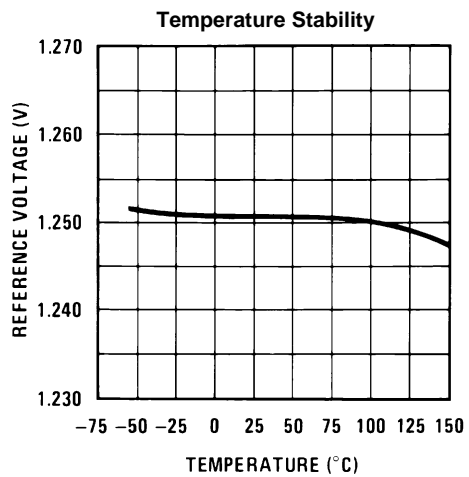

Figure 16.

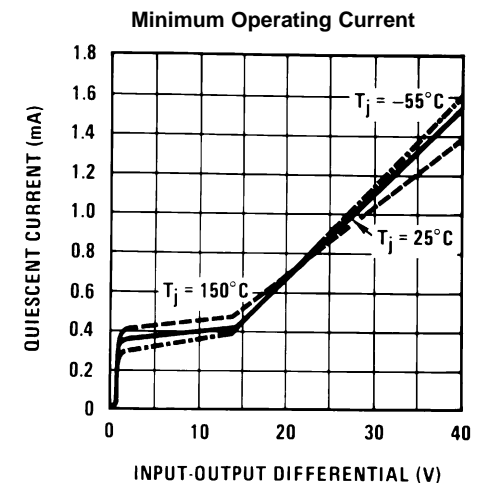

Figure 17.

Typical Performance Characteristics (continued)

(H & K Packages)

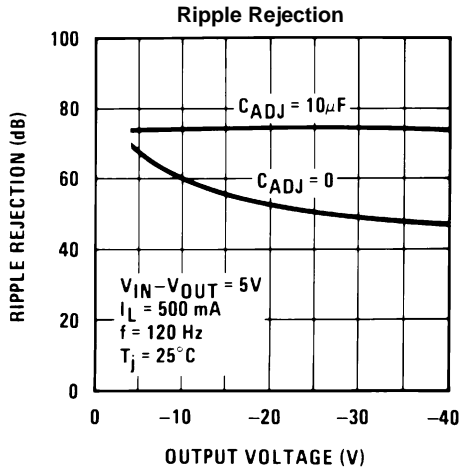

Figure 18.

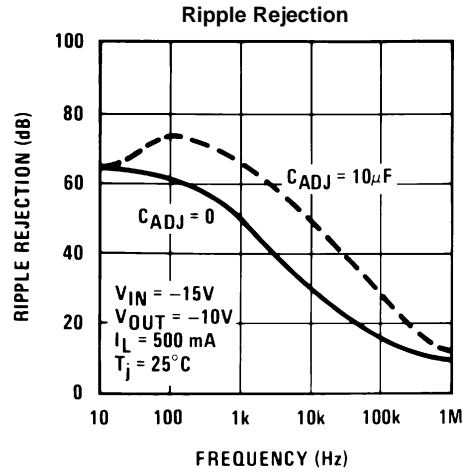

Figure 19.

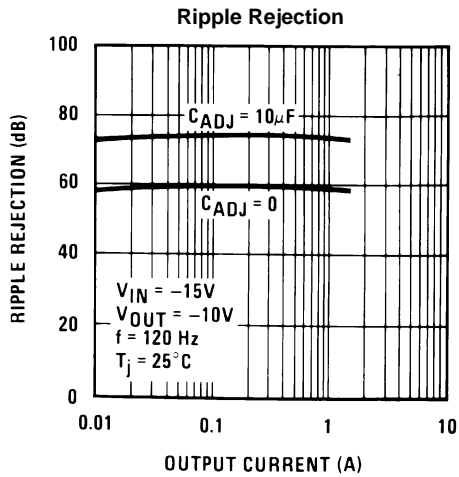

Figure 20.

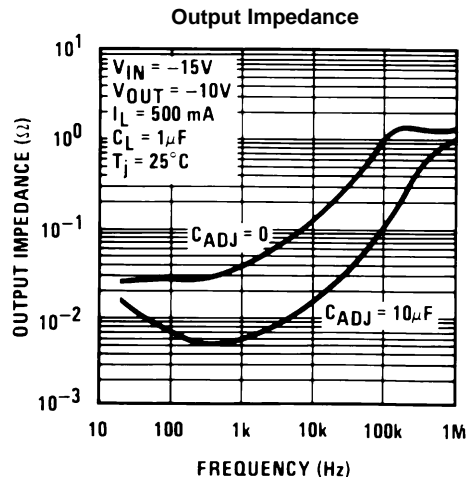

Figure 21.

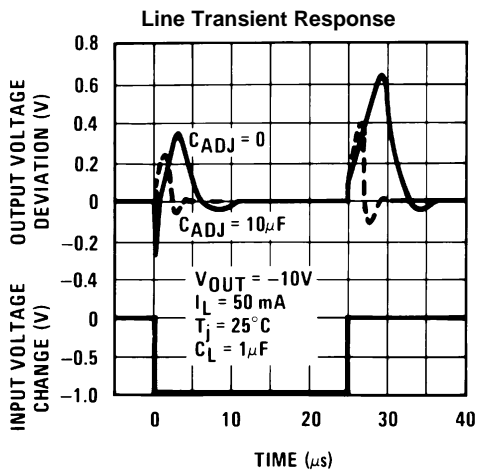

Figure 22.

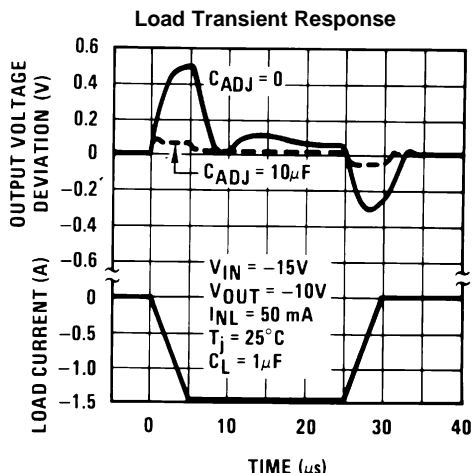

Figure 23.

### REVISION HISTORY

Date Released	Revision	Section	Changes
12/08/2010	A	New Release, Corporate format	2 MDS data sheets converted into one Corp. data sheet format. MJLM137-H Rev. 0A0, MJLM137-K Rev. 0A0. MDS data sheets will be archived.
03/20/2013	A	All	Changed layout of National Data Sheet to TI format

**PACKAGING INFORMATION**

Orderable Device	Status (1)	Package Type	Package Drawing	Pins	Package Qty	Eco Plan (2)	Lead finish/ Ball material (6)	MSL Peak Temp (3)	Op Temp (°C)	Device Marking (4/5)	Samples
JL137BXA	ACTIVE	TO	NDT	3	20	Non-RoHS & Green	Call TI	Level-1-NA-UNLIM	-55 to 150	JL137BXA JM38510/11803BXA Q ACO JM38510/11803BXA Q >T	<a href="#">Samples</a>
JL137SXA	ACTIVE	TO	NDT	3	20	Non-RoHS & Green	Call TI	Level-1-NA-UNLIM	-55 to 150	JL137SXA JM38510/11803SXA Q ACO JM38510/11803SXA Q >T	<a href="#">Samples</a>
JL137SYA	ACTIVE	TO	K	2	50	Non-RoHS & Green	Call TI	Level-1-NA-UNLIM	-55 to 150	JL137SYA Q JM38510/ 11804SYA ACO 11804SYA >T	<a href="#">Samples</a>
JM38510/11803BXA	ACTIVE	TO	NDT	3	20	Non-RoHS & Green	Call TI	Level-1-NA-UNLIM	-55 to 150	JL137BXA JM38510/11803BXA Q ACO JM38510/11803BXA Q >T	<a href="#">Samples</a>
JM38510/11804SYA	ACTIVE	TO	K	2	50	RoHS & Green	Call TI	Level-1-NA-UNLIM	-55 to 150	JL137SYA Q JM38510/ 11804SYA ACO 11804SYA >T	<a href="#">Samples</a>
M38510/11803BXA	ACTIVE	TO	NDT	3	20	Non-RoHS & Green	Call TI	Level-1-NA-UNLIM	-55 to 150	JL137BXA JM38510/11803BXA Q ACO JM38510/11803BXA Q >T	<a href="#">Samples</a>
M38510/11803BXX	ACTIVE	TO	NDT	3	20	Non-RoHS & Green	Call TI	Level-1-NA-UNLIM	-55 to 150	JL137BXA JM38510/11803BXA Q ACO JM38510/11803BXA Q >T	<a href="#">Samples</a>
M38510/11804SYA	ACTIVE	TO	K	2	50	RoHS & Green	Call TI	Level-1-NA-UNLIM	-55 to 150	JL137SYA Q JM38510/ 11804SYA ACO 11804SYA >T	<a href="#">Samples</a>

(1) The marketing status values are defined as follows:

**ACTIVE:** Product device recommended for new designs.

**LIFEBUY:** TI has announced that the device will be discontinued, and a lifetime-buy period is in effect.

**NRND:** Not recommended for new designs. Device is in production to support existing customers, but TI does not recommend using this part in a new design.

**PREVIEW:** Device has been announced but is not in production. Samples may or may not be available.

**OBSOLETE:** TI has discontinued the production of the device.

(2) **RoHS:** TI defines "RoHS" to mean semiconductor products that are compliant with the current EU RoHS requirements for all 10 RoHS substances, including the requirement that RoHS substance do not exceed 0.1% by weight in homogeneous materials. Where designed to be soldered at high temperatures, "RoHS" products are suitable for use in specified lead-free processes. TI may reference these types of products as "Pb-Free".

**RoHS Exempt:** TI defines "RoHS Exempt" to mean products that contain lead but are compliant with EU RoHS pursuant to a specific EU RoHS exemption.

**Green:** TI defines "Green" to mean the content of Chlorine (Cl) and Bromine (Br) based flame retardants meet JS709B low halogen requirements of  $\leq 1000$ ppm threshold. Antimony trioxide based flame retardants must also meet the  $\leq 1000$ ppm threshold requirement.

(3) MSL, Peak Temp. - The Moisture Sensitivity Level rating according to the JEDEC industry standard classifications, and peak solder temperature.

(4) There may be additional marking, which relates to the logo, the lot trace code information, or the environmental category on the device.

(5) Multiple Device Markings will be inside parentheses. Only one Device Marking contained in parentheses and separated by a "~" will appear on a device. If a line is indented then it is a continuation of the previous line and the two combined represent the entire Device Marking for that device.

(6) Lead finish/Ball material - Orderable Devices may have multiple material finish options. Finish options are separated by a vertical ruled line. Lead finish/Ball material values may wrap to two lines if the finish value exceeds the maximum column width.

**Important Information and Disclaimer:**The information provided on this page represents TI's knowledge and belief as of the date that it is provided. TI bases its knowledge and belief on information provided by third parties, and makes no representation or warranty as to the accuracy of such information. Efforts are underway to better integrate information from third parties. TI has taken and continues to take reasonable steps to provide representative and accurate information but may not have conducted destructive testing or chemical analysis on incoming materials and chemicals. TI and TI suppliers consider certain information to be proprietary, and thus CAS numbers and other limited information may not be available for release.

In no event shall TI's liability arising out of such information exceed the total purchase price of the TI part(s) at issue in this document sold by TI to Customer on an annual basis.

**OTHER QUALIFIED VERSIONS OF LM137JAN, LM137JAN-SP :**

● Military : [LM137JAN](#)

● Space : [LM137JAN-SP](#)

NOTE: Qualified Version Definitions:

- Military - QML certified for Military and Defense Applications
- Space - Radiation tolerant, ceramic packaging and qualified for use in Space-based application



**TRAY**

Chamfer on Tray corner indicates Pin 1 orientation of packed units.

\*All dimensions are nominal

Device	Package Name	Package Type	Pins	SPQ	Unit array matrix	Max temperature (°C)	L (mm)	W (mm)	K0 (µm)	P1 (mm)	CL (mm)	CW (mm)
JL137BXA	NDT	TO-CAN	3	20	2 X 10	150	126.49	61.98	8890	11.18	12.95	18.54
JL137SXA	NDT	TO-CAN	3	20	2 X 10	150	126.49	61.98	8890	11.18	12.95	18.54
JL137SYA	K	TO-CAN	2	50	9 X 6	NA	292.1	215.9	25654	3.87	22.3	25.4
JM38510/11803BXA	NDT	TO-CAN	3	20	2 X 10	150	126.49	61.98	8890	11.18	12.95	18.54
JM38510/11804SYA	K	TO-CAN	2	50	9 X 6	NA	292.1	215.9	25654	3.87	22.3	25.4
M38510/11803BXA	NDT	TO-CAN	3	20	2 X 10	150	126.49	61.98	8890	11.18	12.95	18.54
M38510/11803BXX	NDT	TO-CAN	3	20	2 X 10	150	126.49	61.98	8890	11.18	12.95	18.54
M38510/11804SYA	K	TO-CAN	2	50	9 X 6	NA	292.1	215.9	25654	3.87	22.3	25.4

NDT0003A

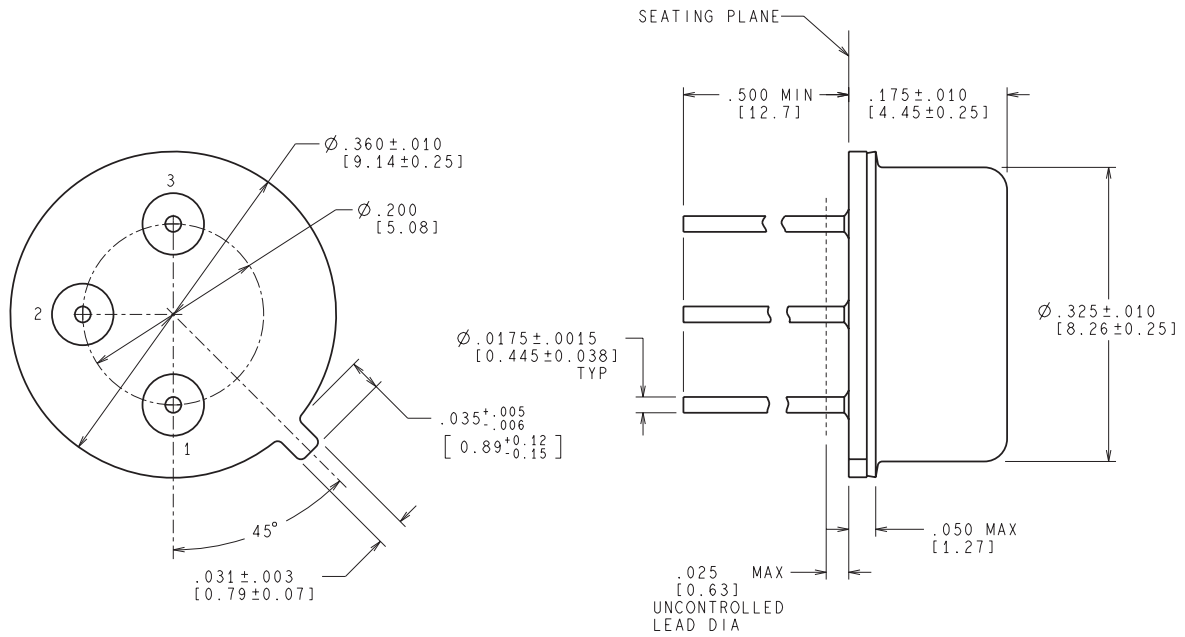

CONTROLLING DIMENSION IS INCH  
VALUES IN [ ] ARE MILLIMETERS

MIL-PRF-38535  
CONFIGURATION CONTROL

H03A (Rev D)

K0002A



# PACKAGE OUTLINE

## TO-CAN - 7.747 mm max height

TRANSISTOR OUTLINE

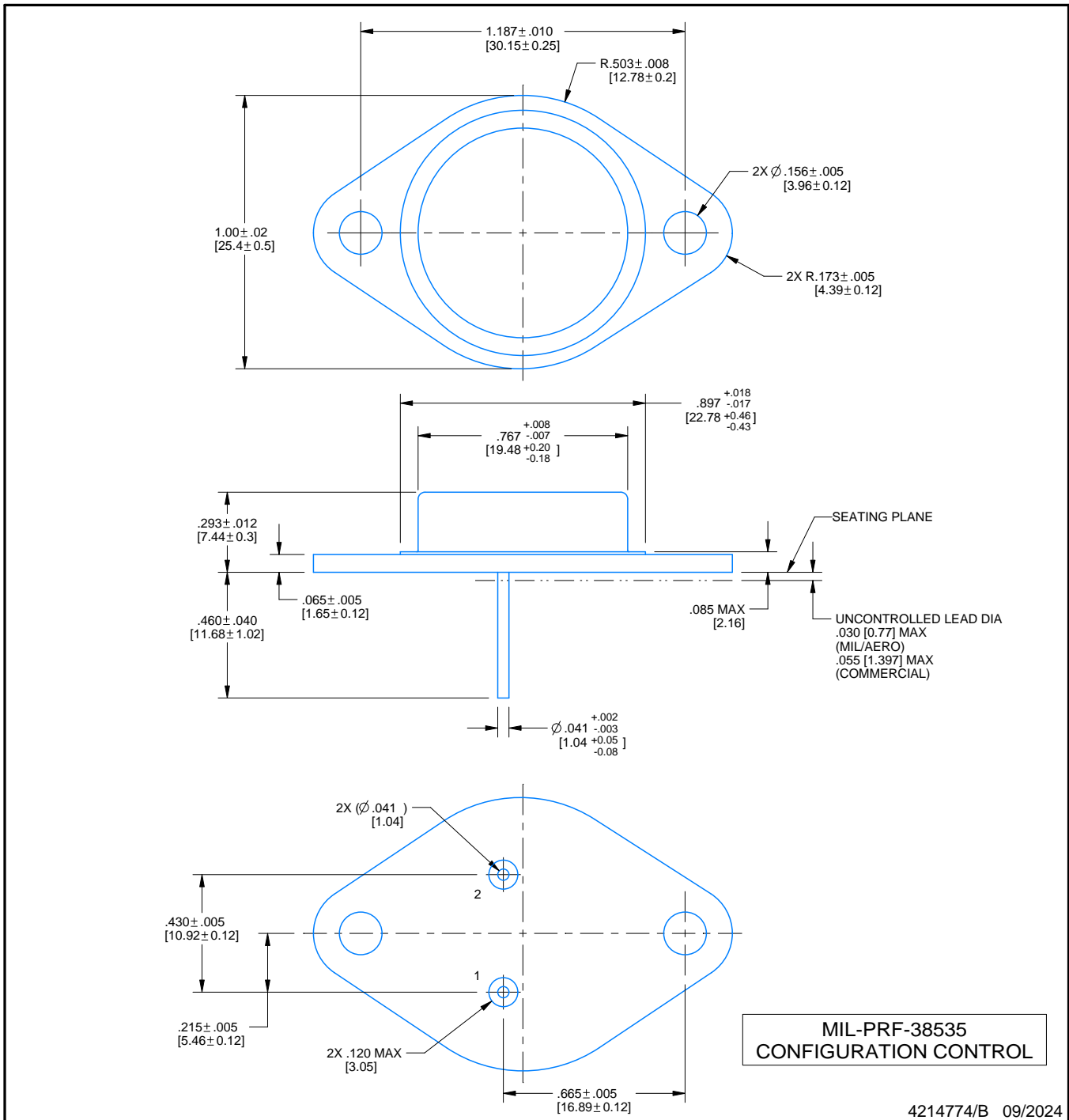

**NOTES:**

1. Linear dimensions are in inches [millimeters]. Dimensions in parenthesis are for reference only. Controlling dimensions are in inches. Dimensioning and tolerancing per ASME Y14.5M.
2. This drawing is subject to change without notice.
3. Leads not to be bent greater than 15°.

## IMPORTANT NOTICE AND DISCLAIMER

TI PROVIDES TECHNICAL AND RELIABILITY DATA (INCLUDING DATA SHEETS), DESIGN RESOURCES (INCLUDING REFERENCE DESIGNS), APPLICATION OR OTHER DESIGN ADVICE, WEB TOOLS, SAFETY INFORMATION, AND OTHER RESOURCES "AS IS" AND WITH ALL FAULTS, AND DISCLAIMS ALL WARRANTIES, EXPRESS AND IMPLIED, INCLUDING WITHOUT LIMITATION ANY IMPLIED WARRANTIES OF MERCHANTABILITY, FITNESS FOR A PARTICULAR PURPOSE OR NON-INFRINGEMENT OF THIRD PARTY INTELLECTUAL PROPERTY RIGHTS.

These resources are intended for skilled developers designing with TI products. You are solely responsible for (1) selecting the appropriate TI products for your application, (2) designing, validating and testing your application, and (3) ensuring your application meets applicable standards, and any other safety, security, regulatory or other requirements.

These resources are subject to change without notice. TI grants you permission to use these resources only for development of an application that uses the TI products described in the resource. Other reproduction and display of these resources is prohibited. No license is granted to any other TI intellectual property right or to any third party intellectual property right. TI disclaims responsibility for, and you will fully indemnify TI and its representatives against, any claims, damages, costs, losses, and liabilities arising out of your use of these resources.

TI's products are provided subject to [TI's Terms of Sale](#) or other applicable terms available either on [ti.com](https://www.ti.com) or provided in conjunction with such TI products. TI's provision of these resources does not expand or otherwise alter TI's applicable warranties or warranty disclaimers for TI products.

TI objects to and rejects any additional or different terms you may have proposed.

Mailing Address: Texas Instruments, Post Office Box 655303, Dallas, Texas 75265  
Copyright © 2025, Texas Instruments Incorporated