

LM2587 4V~40V、5A 昇圧、広 V_{IN} のフライバック・レギュレータ

1 特長

- 必要な外付け部品が少ない
- 標準のインダクタおよびトランス・ファミリ
- 耐圧 65V、5A の NPN 出力スイッチ
- 広い入力電圧範囲：4V~40V
- 電流モード動作により優れた過渡応答、ライン・レギュレーション、電流制限を実現
- 100kHz の固定スイッチング周波数
- 内部ソフトスタート機能により起動時の突入電流を低減
- 電流制限、低電圧誤動作防止、サーマル・シャットダウンにより出力トランジスタを保護
- システムの出力電圧許容差：規定のラインおよび負荷条件で最大 $\pm 4\%$
- **WEBENCH® Power Designer** により、LM2587 を使用するカスタム設計を作成

2 代表的なアプリケーション

- フライバック・レギュレータ
- 多出力レギュレータ
- シンプルな昇圧レギュレータ
- フォワード・コンバータ

3 概要

LM2587 シリーズのレギュレータは、フライバック、昇圧、およびフォワード・コンバータ用に設計されたモノリシック IC です。3.3V、5V、12V、可変型の 4 種の出力電圧バージョンがあります。

最小限の外付け部品で回路を構成できる、コスト効果の高い、使いやすいレギュレータです。データシートには、昇圧レギュレータとフライバック・レギュレータの代表的な回路例が記載されています。また、ダイオードとコンデンサの選択ガイド、これらのスイッチング・レギュレータと組み合わせて使用できる標準のインダクタおよびフライバック・トランスファミリについても記載されています。

電源スイッチは耐圧 65V、5A の NPN デバイスで、電流および熱制限回路と、低電圧誤動作防止回路により保護されます。この IC は 100kHz 固定周波数発振器を内蔵しているため、小型の磁気部品を使用できます。加えて、ソフトスタート・モードによる起動時突入電流の低減、電流モード制御による入力電圧および出力負荷過渡除去性能の向上、サイクル単位の電流制限といった特長も備えています。電源システムは、規定の入力電圧および出力負荷条件の範囲で、 $\pm 4\%$ の出力電圧許容差が保証されています。

製品情報⁽¹⁾

型番	パッケージ	本体サイズ(公称)
LM2587	DDPAK/TO-263 (5)	10.16mmx8.42mm
	TO-220 (5)	14.986mmx10.16mm

(1) 提供されているすべてのパッケージについては、巻末の注文情報を参照してください。

フライバック・レギュレータ

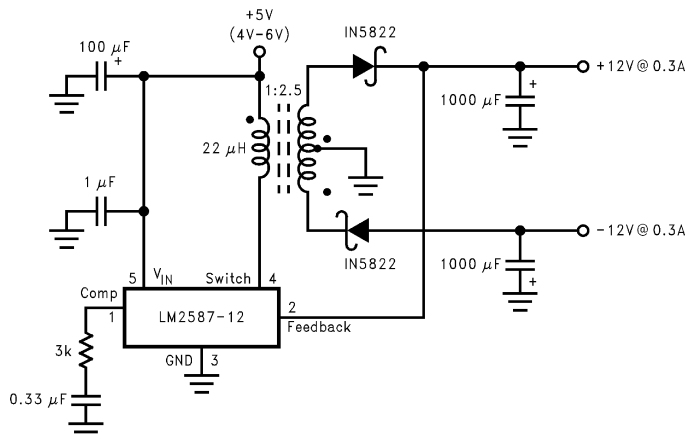

目次

1	特長	1	7.2	Functional Block Diagram	13
2	代表的なアプリケーション	1	7.3	Feature Description	14
3	概要	1	8	Application And Implementation	15
4	改訂履歴	2	8.1	Application Information	15
5	Pin Configurations	3	8.2	Typical Applications	15
6	Specifications	4	8.3	Additional Application Examples	27
6.1	Absolute Maximum Ratings	4	9	Layout	28
6.2	ESDRatings	4	9.1	Layout Guidelines	28
6.3	Recommended Operating Ratings	4	9.2	Layout Example	28
6.4	Thermal Information	5	9.3	Heat Sink/Thermal Considerations	28
6.5	Electrical Characteristics: 3.3 V	5	10	デバイスおよびドキュメントのサポート	31
6.6	Electrical Characteristics: 5 V	6	10.1	デバイス・サポート	31
6.7	Electrical Characteristics: 12 V	6	10.2	ドキュメントの更新通知を受け取る方法	31
6.8	Electrical Characteristics: Adjustable	7	10.3	コミュニティ・リソース	31
6.9	Electrical Characteristics: All Output Voltage Versions	7	10.4	商標	31
6.10	Typical Characteristics	9	10.5	静電気放電に関する注意事項	31
7	Detailed Description	12	10.6	Glossary	32
7.1	Overview	12	11	メカニカル、パッケージ、および注文情報	32

4 改訂履歴

資料番号末尾の英字は改訂を表しています。その改訂履歴は英語版に準じています。

Revision D (April 2013) から Revision E に変更		Page
•	編集上の変更のみ、技術上の修正なし、WEBENCH のリンクを追加	1
Revision C (April 2013) から Revision D に変更		Page
•	Changed layout of National Data Sheet to TI format	30

5 Pin Configurations

**NDH Package
5-Pin TO-220
Top View, Bent Staggered Leads**



**KTT Package
5-Pin DDPAK/TO-263
Top View**

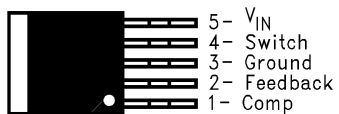

**NDH Package
5-Pin TO-220
Side View, Bent Staggered Leads**



**KTT Package
5-Pin DDPAK/TO-263
Side View**



6 Specifications

6.1 Absolute Maximum Ratings

over operating free-air temperature range (unless otherwise noted)⁽¹⁾⁽²⁾

Input Voltage		$-0.4V \leq V_{IN} \leq 45V$
Switch Voltage		$-0.4V \leq V_{SW} \leq 65V$
Switch Current ⁽³⁾		Internally Limited
Compensation Pin Voltage		$-0.4V \leq V_{COMP} \leq 2.4V$
Feedback Pin Voltage		$-0.4V \leq V_{FB} \leq 2 V_{OUT}$
Storage Temperature Range		$-65^{\circ}C$ to $+150^{\circ}C$
Lead Temperature	(Soldering, 10 sec.)	$260^{\circ}C$
Maximum Junction	Temperature ⁽⁴⁾	$150^{\circ}C$
Power Dissipation ⁽⁴⁾		Internally Limited

- (1) Absolute Maximum Ratings indicate limits beyond which damage to the device may occur. Operating ratings indicate conditions the device is intended to be functional, but device parameter specifications may not be specified under these conditions. For specifications and test conditions see .
- (2) If Military/Aerospace specified devices are required, contact the Texas Instruments Sales Office/ Distributors for availability and specifications.
- (3) Note that switch current and output current are not identical in a step-up regulator. Output current cannot be internally limited when the LM2587 is used as a step-up regulator. To prevent damage to the switch, the output current must be externally limited to 5A. However, output current is internally limited when the LM2587 is used as a flyback regulator (see the section for more information).
- (4) The junction temperature of the device (T_J) is a function of the ambient temperature (T_A), the junction-to-ambient thermal resistance (θ_{JA}), and the power dissipation of the device (P_D). A thermal shutdown will occur if the temperature exceeds the maximum junction temperature of the device: $P_D \times \theta_{JA} + T_{A(MAX)} \geq T_{J(MAX)}$. For a safe thermal design, check that the maximum power dissipated by the device is less than: $P_D \leq [T_{J(MAX)} - T_{A(MAX)}] / \theta_{JA}$. When calculating the maximum allowable power dissipation, derate the maximum junction temperature—this ensures a margin of safety in the thermal design.

6.2 ESD Ratings

			VALUE	UNIT
$V_{(ESD)}$	Electrostatic discharge (minimum)	Human-body model (HBM), per ANSI/ESDA/JEDEC JS-001 ⁽¹⁾ ($C = 100$ pF, $R = 1.5$ k Ω)	2000	V

- (1) JEDEC document JEP155 states that 500-V HBM allows safe manufacturing with a standard ESD control process.

6.3 Recommended Operating Ratings

Supply Voltage	$4V \leq V_{IN} \leq 40V$
Output Switch Voltage	$0V \leq V_{SW} \leq 60V$
Output Switch Current	$I_{SW} \leq 5.0A$
Junction Temperature Range	$-40^{\circ}C \leq T_J \leq +125^{\circ}C$

6.4 Thermal Information

THERMAL METRIC ⁽¹⁾⁽²⁾		LM2585		UNIT
		KTT (DDPAK/TO-263)	NDH (TO-220)	
		5 PINS	5 PINS	
R _{θJA}	Junction-to-ambient thermal resistance	56 ⁽³⁾	65 ⁽⁴⁾	°C/W
		35 ⁽⁵⁾	45 ⁽⁶⁾	
		26 ⁽⁷⁾	—	
R _{θJC}	Junction-to-case thermal resistance	2	2	°C/W

- (1) For more information about traditional and new thermal metrics, see the [Semiconductor and IC package thermal metrics application report](#).
- (2) External components such as the diode, inductor, input and output capacitors can affect switching regulator performance. When the LM2587 is used as shown in [Figure 61](#) and [Figure 62](#), system performance will be as specified by the system parameters.
- (3) Junction-to-ambient thermal resistance for the 5 lead TO-263 mounted horizontally against a PC board area of 0.136 square inches (the same size as the TO-263 package) of 1 oz. (0.0014 in. thick) copper.
- (4) Junction-to-ambient thermal resistance (no external heat sink) for the 5 lead TO-220 package mounted vertically, with ½ inch leads in a socket, or on a PC board with minimum copper area.
- (5) Junction-to-ambient thermal resistance for the 5 lead TO-263 mounted horizontally against a PC board area of 0.4896 square inches (3.6 times the area of the TO-263 package) of 1 oz. (0.0014 in. thick) copper.
- (6) Junction-to-ambient thermal resistance (no external heat sink) for the 5 lead TO-220 package mounted vertically, with ½ inch leads soldered to a PC board containing approximately 4 square inches of (1oz.) copper area surrounding the leads.
- (7) Junction-to-ambient thermal resistance for the 5 lead TO-263 mounted horizontally against a PC board copper area of 1.0064 square inches (7.4 times the area of the TO-263 package) of 1 oz. (0.0014 in. thick) copper. Additional copper area reduces thermal resistance further. See the thermal model in Switchers Made Simple[®] software.

6.5 Electrical Characteristics: 3.3 V

Specifications with standard type face are for T_J = 25°C, and those in **bold** apply over full **Operating Temperature Range**. Unless otherwise specified, V_{IN} = 5V.

PARAMETER		TEST CONDITIONS	TYP	MIN	MAX	UNIT
SYSTEM PARAMETERS Test Circuit of Figure 61 ⁽¹⁾						
V _{OUT}	Output Voltage	V _{IN} = 4V to 12V I _{LOAD} = 400 mA to 1.75A	3.3	3.17/ 3.14	3.43/ 3.46	V
ΔV _{OUT} / ΔV _{IN}	Line Regulation	V _{IN} = 4V to 12V I _{LOAD} = 400 mA	20		50/ 100	mV
ΔV _{OUT} / ΔI _{LOAD}	Load Regulation	V _{IN} = 12V I _{LOAD} = 400 mA to 1.75A	20		50/ 100	mV
η	Efficiency	V _{IN} = 12V, I _{LOAD} = 1A	75			%
UNIQUE DEVICE PARAMETERS ⁽²⁾						
V _{REF}	Output Reference Voltage	Measured at Feedback Pin V _{COMP} = 1.0V	3.3	3.242/ 3.234	3.358/ 3.366	V
ΔV _{REF}	Reference Voltage Line Regulation	V _{IN} = 4V to 40V	2.0			mV
G _M	Error Amp Transconductance	I _{COMP} = -30 μA to +30 μA V _{COMP} = 1.0V	1.193	0.678	2.259	mmho
A _{VOL}	Error Amp Voltage Gain	V _{COMP} = 0.5V to 1.6V R _{COMP} = 1.0 MΩ ⁽³⁾	260	151/ 75		V/V

- (1) External components such as the diode, inductor, input and output capacitors can affect switching regulator performance. When the LM2587 is used as shown in [Figure 61](#) and [Figure 62](#), system performance will be as specified by the system parameters.
- (2) All room temperature limits are 100% production tested, and all limits at temperature extremes are specified via correlation using standard Statistical Quality Control (SQC) methods.
- (3) A 1-MΩ resistor is connected to the compensation pin (which is the error amplifier output) to ensure accuracy in measuring A_{VOL}.

6.6 Electrical Characteristics: 5 V

Specifications with standard type face are for $T_J = 25^\circ\text{C}$, and those in **bold** apply over full **Operating Temperature Range**. Unless otherwise specified, $V_{IN} = 5\text{V}$.

PARAMETER		TEST CONDITIONS	TYP	MIN	MAX	UNIT
SYSTEM PARAMETERS Test Circuit of Figure 61 ⁽¹⁾						
V_{OUT}	Output Voltage	$V_{IN} = 4\text{V to }12\text{V}$ $I_{LOAD} = 500\text{ mA to }1.45\text{A}$	5.0	4.80/ 4.75	5.20/ 5.25	V
$\frac{\Delta V_{OUT}}{\Delta V_{IN}}$	Line Regulation	$V_{IN} = 4\text{V to }12\text{V}$ $I_{LOAD} = 500\text{ mA}$	20		50/ 100	mV
$\frac{\Delta V_{OUT}}{\Delta I_{LOAD}}$	Load Regulation	$V_{IN} = 12\text{V}$ $I_{LOAD} = 500\text{ mA to }1.45\text{A}$	20		50/ 100	mV
η	Efficiency	$V_{IN} = 12\text{V}$, $I_{LOAD} = 750\text{ mA}$	80			%
UNIQUE DEVICE PARAMETERS ⁽²⁾						
V_{REF}	Output Reference Voltage	Measured at Feedback Pin $V_{COMP} = 1.0\text{V}$	5.0	4.913/ 4.900	5.088/ 5.100	V
ΔV_{REF}	Reference Voltage Line Regulation	$V_{IN} = 4\text{V to }40\text{V}$	3.3			mV
G_M	Error Amp Transconductance	$I_{COMP} = -30\ \mu\text{A to }+30\ \mu\text{A}$ $V_{COMP} = 1.0\text{V}$	0.750	0.447	1.491	mmho
A_{VOL}	Error Amp Voltage Gain	$V_{COMP} = 0.5\text{V to }1.6\text{V}$ $R_{COMP} = 1.0\ \text{M}\Omega$ ⁽³⁾	165	99/ 49		V/V

- (1) External components such as the diode, inductor, input and output capacitors can affect switching regulator performance. When the LM2587 is used as shown in [Figure 61](#) and [Figure 62](#), system performance will be as specified by the system parameters.
- (2) All room temperature limits are 100% production tested, and all limits at temperature extremes are specified via correlation using standard Statistical Quality Control (SQC) methods.
- (3) A 1-M Ω resistor is connected to the compensation pin (which is the error amplifier output) to ensure accuracy in measuring A_{VOL} .

6.7 Electrical Characteristics: 12 V

Specifications with standard type face are for $T_J = 25^\circ\text{C}$, and those in **bold** apply over full **Operating Temperature Range**. Unless otherwise specified, $V_{IN} = 5\text{V}$.

PARAMETER		TEST CONDITIONS	TYP	MIN	MAX	UNIT
SYSTEM PARAMETERS Test Circuit of Figure 62 ⁽¹⁾						
V_{OUT}	Output Voltage	$V_{IN} = 4\text{V to }10\text{V}$ $I_{LOAD} = 300\text{ mA to }1.2\text{A}$	12.0	11.52/ 11.40	12.48/ 12.60	V
$\frac{\Delta V_{OUT}}{\Delta V_{IN}}$	Line Regulation	$V_{IN} = 4\text{V to }10\text{V}$ $I_{LOAD} = 300\text{ mA}$	20		100/ 200	mV
$\frac{\Delta V_{OUT}}{\Delta I_{LOAD}}$	Load Regulation	$V_{IN} = 10\text{V}$ $I_{LOAD} = 300\text{ mA to }1.2\text{A}$	20		100/ 200	mV
η	Efficiency	$V_{IN} = 10\text{V}$, $I_{LOAD} = 1\text{A}$	90			%
UNIQUE DEVICE PARAMETERS ⁽²⁾						
V_{REF}	Output Reference Voltage	Measured at Feedback Pin $V_{COMP} = 1.0\text{V}$	12.0	11.79/ 11.76	12.21/ 12.24	V
ΔV_{REF}	Reference Voltage Line Regulation	$V_{IN} = 4\text{V to }40\text{V}$	7.8			mV
G_M	Error Amp Transconductance	$I_{COMP} = -30\ \mu\text{A to }+30\ \mu\text{A}$ $V_{COMP} = 1.0\text{V}$	0.328	0.186	0.621	mmho
A_{VOL}	Error Amp Voltage Gain	$V_{COMP} = 0.5\text{V to }1.6\text{V}$ $R_{COMP} = 1.0\ \text{M}\Omega$ ⁽³⁾	70	41/ 21		V/V

- (1) External components such as the diode, inductor, input and output capacitors can affect switching regulator performance. When the LM2587 is used as shown in [Figure 61](#) and [Figure 62](#), system performance will be as specified by the system parameters.
- (2) All room temperature limits are 100% production tested, and all limits at temperature extremes are specified via correlation using standard Statistical Quality Control (SQC) methods.
- (3) A 1-M Ω resistor is connected to the compensation pin (which is the error amplifier output) to ensure accuracy in measuring A_{VOL} .

6.8 Electrical Characteristics: Adjustable

Specifications with standard type face are for $T_J = 25^\circ\text{C}$, and those in **bold type face** apply over full **Operating Temperature Range**. Unless otherwise specified, $V_{IN} = 5\text{V}$.

PARAMETER	TEST CONDITIONS	TYP	MIN	MAX	UNIT	
SYSTEM PARAMETERS Test Circuit of Figure 62 ⁽¹⁾						
V_{OUT}	Output Voltage	$V_{IN} = 4\text{V to }10\text{V}$ $I_{LOAD} = 300\text{ mA to }1.2\text{A}$	12.0	11.52/ 11.40	12.48/ 12.60	V
$\frac{\Delta V_{OUT}}{\Delta V_{IN}}$	Line Regulation	$V_{IN} = 4\text{V to }10\text{V}$ $I_{LOAD} = 300\text{ mA}$	20		100/ 200	mV
$\frac{\Delta V_{OUT}}{\Delta I_{LOAD}}$	Load Regulation	$V_{IN} = 10\text{V}$ $I_{LOAD} = 300\text{ mA to }1.2\text{A}$	20		100/ 200	mV
η	Efficiency	$V_{IN} = 10\text{V}$, $I_{LOAD} = 1\text{A}$	90			%
UNIQUE DEVICE PARAMETERS ⁽²⁾						
V_{REF}	Output Reference Voltage	Measured at Feedback Pin $V_{COMP} = 1.0\text{V}$	1.230	1.208/ 1.205	1.252/ 1.255	V
ΔV_{REF}	Reference Voltage Line Regulation	$V_{IN} = 4\text{V to }40\text{V}$	1.5			mV
G_M	Error Amp Transconductance	$I_{COMP} = -30\ \mu\text{A to }+30\ \mu\text{A}$ $V_{COMP} = 1.0\text{V}$	3.200	1.800	6.000	mmho
A_{VOL}	Error Amp Voltage Gain	$V_{COMP} = 0.5\text{V to }1.6\text{V}$ $R_{COMP} = 1.0\ \text{M}\Omega$ ⁽³⁾	670	400/ 200		V/V
I_B	Error Amp Input Bias Current	$V_{COMP} = 1.0\text{V}$	125		425/ 600	nA

(1) External components such as the diode, inductor, input and output capacitors can affect switching regulator performance. When the LM2587 is used as shown in [Figure 61](#) and [Figure 62](#), system performance will be as specified by the system parameters.

(2) All room temperature limits are 100% production tested, and all limits at temperature extremes are specified via correlation using standard Statistical Quality Control (SQC) methods.

(3) A 1-M Ω resistor is connected to the compensation pin (which is the error amplifier output) to ensure accuracy in measuring A_{VOL} .

6.9 Electrical Characteristics: All Output Voltage Versions⁽¹⁾

Specifications with standard type face are for $T_J = 25^\circ\text{C}$, and those in **bold type face** apply over full **Operating Temperature Range**. Unless otherwise specified, $V_{IN} = 5\text{V}$.

PARAMETER	TEST CONDITIONS	TYP	MIN	MAX	UNIT	
I_S	Input Supply Current	(Switch Off) See ⁽²⁾	11		15.5/ 16.5	mA
		$I_{SWITCH} = 3.0\text{A}$	85		140/ 165	mA
V_{UV}	Input Supply Undervoltage Lockout	$R_{LOAD} = 100\ \Omega$	3.30	3.05	3.75	V
f_O	Oscillator Frequency	Measured at Switch Pin $R_{LOAD} = 100\ \Omega$ $V_{COMP} = 1.0\text{V}$	100	85/75	115/125	kHz
f_{SC}	Short-Circuit Frequency	Measured at Switch Pin $R_{LOAD} = 100\ \Omega$ $V_{FEEDBACK} = 1.15\text{V}$	25			kHz
V_{EAO}	Error Amplifier Output Swing	Upper Limit See ⁽³⁾	2.8	2.6/ 2.4		V
		Lower Limit See ⁽²⁾	0.25		0.40/ 0.55	V
I_{EAO}	Error Amp Output Current (Source or Sink)	See ⁽⁴⁾	165	110/ 70	260/ 320	μA

(1) All room temperature limits are 100% production tested, and all limits at temperature extremes are specified via correlation using standard Statistical Quality Control (SQC) methods.

(2) To measure this parameter, the feedback voltage is set to a high value, depending on the output version of the device, to force the error amplifier output low. Adj: $V_{FB} = 1.41\text{ V}$; 3.3 V: $V_{FB} = 3.8\text{ V}$; 5 V: $V_{FB} = 5.75\text{ V}$; 12 V: $V_{FB} = 13.8\text{ V}$.

(3) To measure this parameter, the feedback voltage is set to a low value, depending on the output version of the device, to force the error amplifier output high. Adj: $V_{FB} = 1.05\text{ V}$; 3.3 V: $V_{FB} = 2.81\text{ V}$; 5 V: $V_{FB} = 4.25\text{ V}$; 12 V: $V_{FB} = 10.2\text{ V}$.

(4) To measure the worst-case error amplifier output current, the LM2587 is tested with the feedback voltage set to its low value (specified in Note 7) and at its high value (specified in Note 8).

Electrical Characteristics: All Output Voltage Versions ⁽¹⁾ (continued)

Specifications with standard type face are for $T_J = 25^\circ\text{C}$, and those in **bold type face** apply over full **Operating Temperature Range**. Unless otherwise specified, $V_{IN} = 5\text{V}$.

PARAMETER		TEST CONDITIONS	TYP	MIN	MAX	UNIT
I_{SS}	Soft Start Current	$V_{FEEDBACK} = 0.92\text{V}$ $V_{COMP} = 1.0\text{V}$	11.0	8.0/ 7.0	17.0/ 19.0	μA
D	Maximum Duty Cycle	$R_{LOAD} = 100\Omega$ See ⁽³⁾	98	93/ 90		%
I_L	Switch Leakage Current	Switch Off $V_{SWITCH} = 60\text{V}$	15		300/ 600	μA
V_{SUS}	Switch Sustaining Voltage	$dV/dT = 1.5\text{V/ns}$		65		V
V_{SAT}	Switch Saturation Voltage	$I_{SWITCH} = 5.0\text{A}$	0.7		1.1/ 1.4	V
I_{CL}	NPN Switch Current Limit		6.5	5.0	9.5	A

6.10 Typical Characteristics

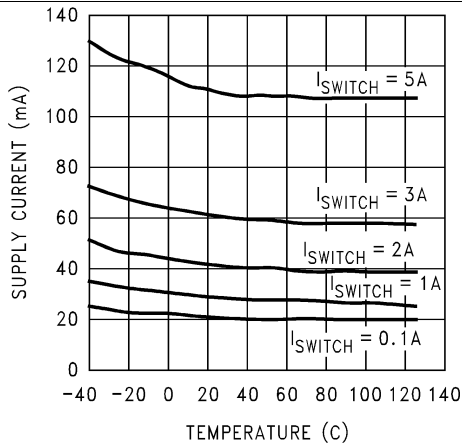

Figure 1. Supply Current vs Temperature

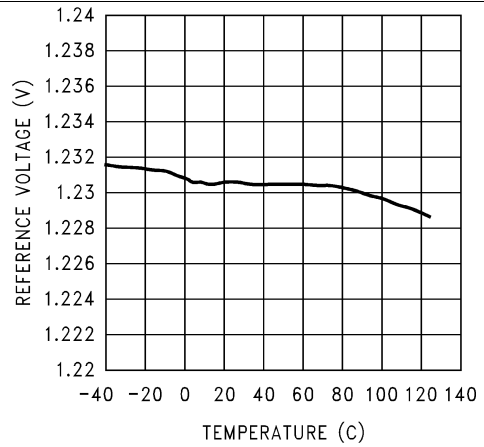

Figure 2. Reference Voltage vs Temperature

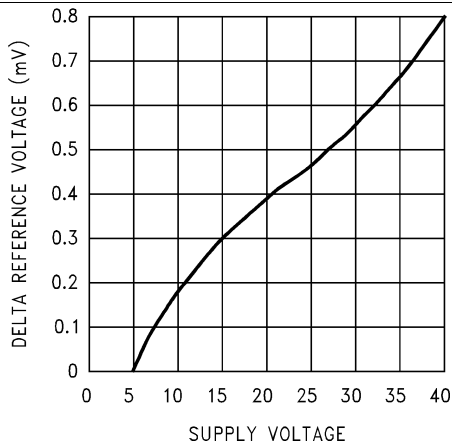

Figure 3. ΔReference Voltage vs Supply Voltage

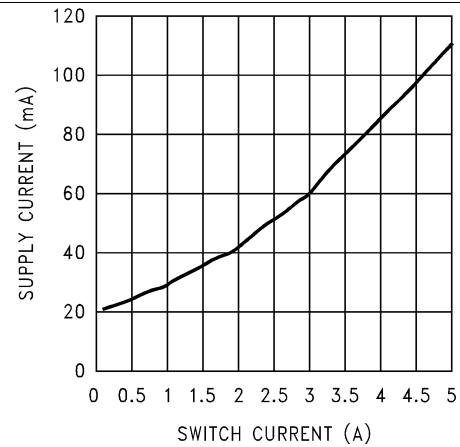

Figure 4. Supply Current vs Switch Current

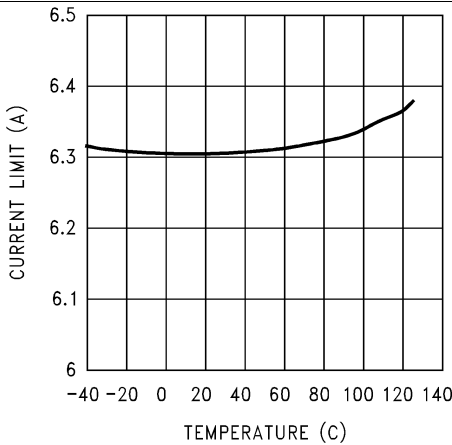

Figure 5. Current Limit vs Temperature

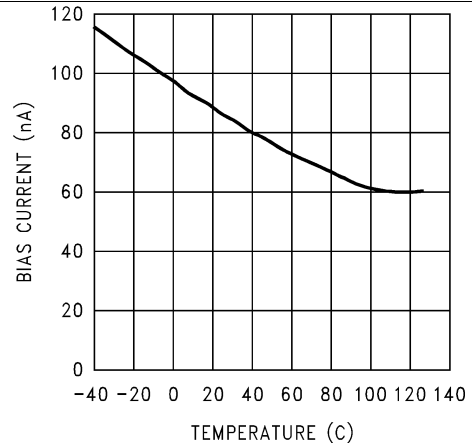

Figure 6. Feedback Pin Bias Current vs Temperature

Typical Characteristics (continued)

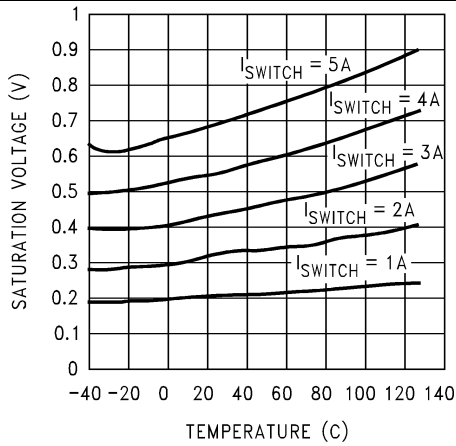

Figure 7. Switch Saturation Voltage vs Temperature

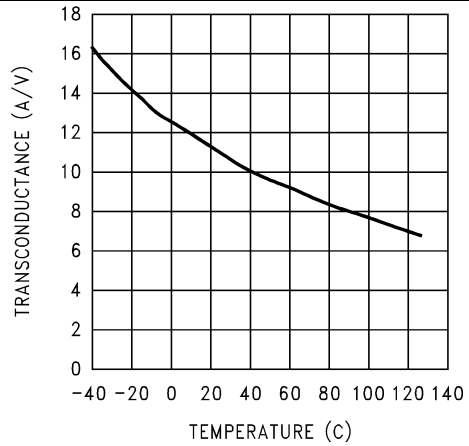

Figure 8. Switch Transconductance vs Temperature

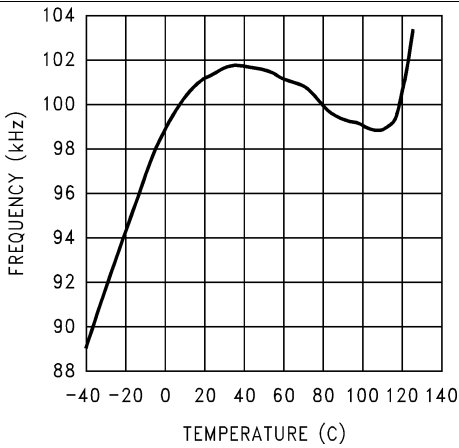

Figure 9. Oscillator Frequency vs Temperature

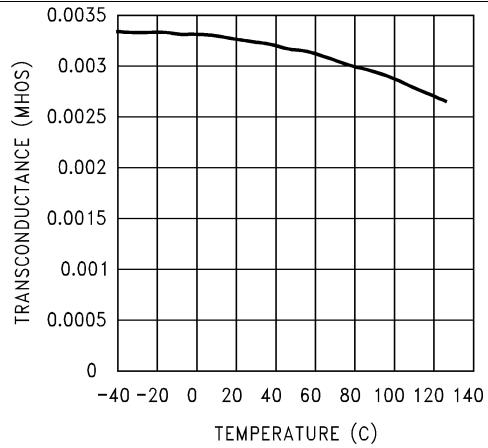

Figure 10. Error Amp Transconductance vs Temperature

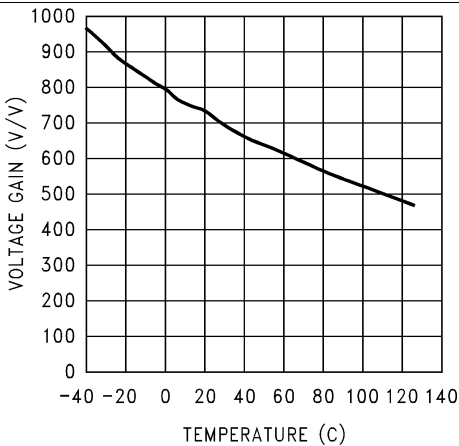

Figure 11. Error Amp Voltage Gain vs Temperature

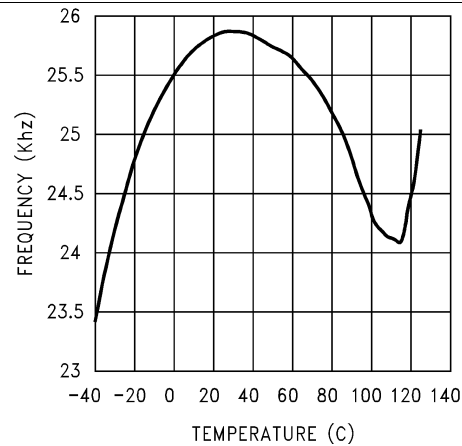
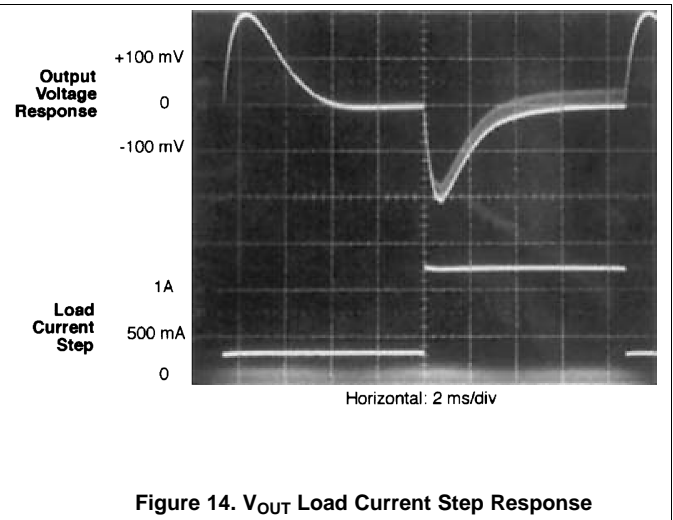
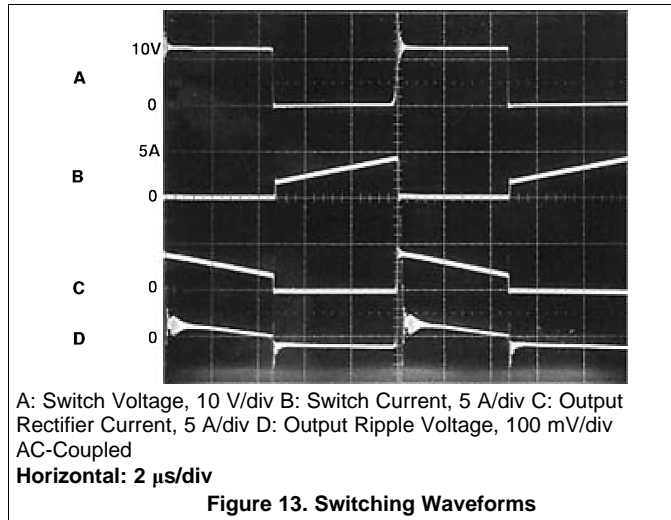

Figure 12. Short Circuit Frequency vs Temperature

Typical Characteristics (continued)



7 Detailed Description

7.1 Overview

The LM2587 is ideally suited for use in the flyback regulator topology. The flyback regulator can produce a single output voltage, such as the one shown in Figure 15, or multiple output voltages. In Figure 15, the flyback regulator generates an output voltage that is inside the range of the input voltage. This feature is unique to flyback regulators and cannot be duplicated with buck or boost regulators.

The operation of a flyback regulator is as follows (refer to Figure 15): when the switch is on, current flows through the primary winding of the transformer, T1, storing energy in the magnetic field of the transformer. Note that the primary and secondary windings are out of phase, so no current flows through the secondary when current flows through the primary. When the switch turns off, the magnetic field collapses, reversing the voltage polarity of the primary and secondary windings. Now rectifier D1 is forward biased and current flows through it, releasing the energy stored in the transformer. This produces voltage at the output.

The output voltage is controlled by modulating the peak switch current. This is done by feeding back a portion of the output voltage to the error amp, which amplifies the difference between the feedback voltage and a 1.23-V reference. The error amp output voltage is compared to a ramp voltage proportional to the switch current (in other words, inductor current during the switch on time). The comparator terminates the switch on time when the two voltages are equal, thereby controlling the peak switch current to maintain a constant output voltage.

As shown in Figure 15, the LM2587 can be used as a flyback regulator by using a minimum number of external components. The switching waveforms of this regulator are shown in Figure 13. Typical Performance Characteristics observed during the operation of this circuit are shown in Figure 14.

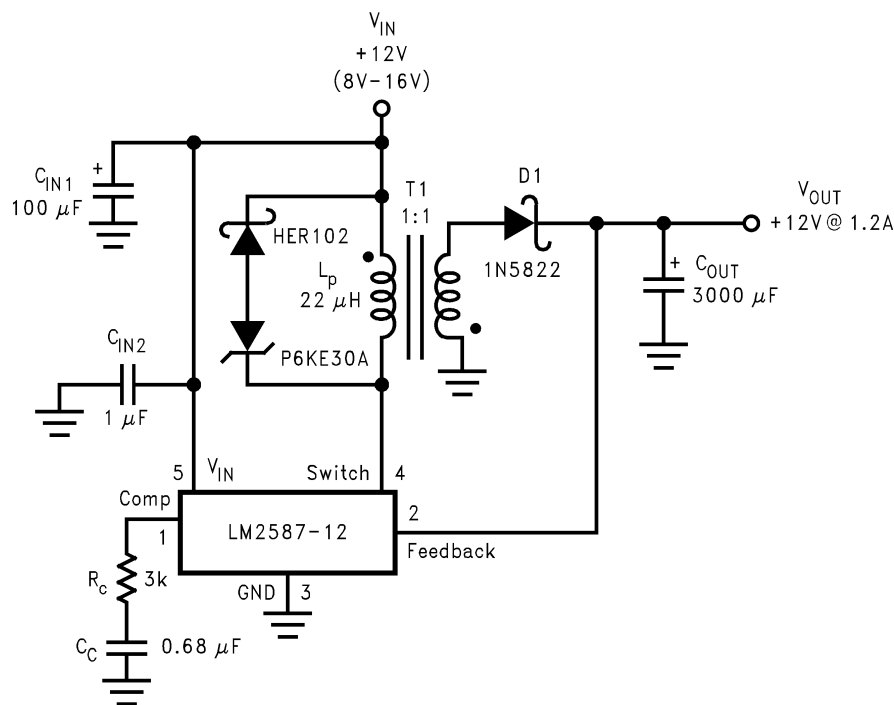

Figure 15. 12-V Flyback Regulator Design Example

For Fixed Versions 3.3 V, R1 = 3.4 k, R2 = 2 k, 5 V, R1 = 6.15 k, R2 = 2k 12V, R1 = 8.73 k, R2 = 1 k. For Adj. Version R1 = Short (0Ω), R2 = Open

7.3 Feature Description

7.3.1 Step-Up (Boost) Regulator Operation

Figure 16 shows the LM2587 used as a step-up (boost) regulator. This is a switching regulator that produces an output voltage greater than the input supply voltage.

A brief explanation of how the LM2587 Boost Regulator works is as follows (refer to Figure 16). When the NPN switch turns on, the inductor current ramps up at the rate of V_{IN}/L , storing energy in the inductor. When the switch turns off, the lower end of the inductor flies above V_{IN} , discharging its current through diode (D) into the output capacitor (C_{OUT}) at a rate of $(V_{OUT} - V_{IN})/L$. Thus, energy stored in the inductor during the switch on time is transferred to the output during the switch off time. The output voltage is controlled by adjusting the peak switch current, as described in the section.

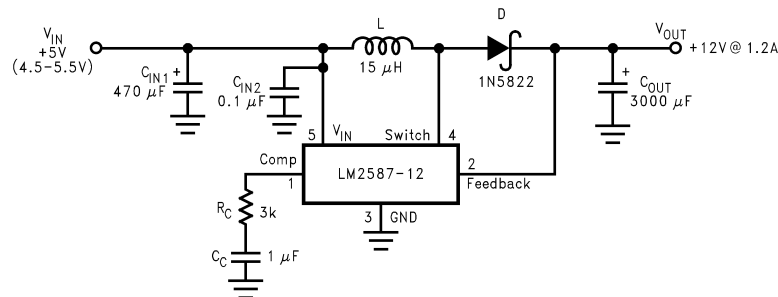

By adding a small number of external components (as shown in Figure 16), the LM2587 can be used to produce a regulated output voltage that is greater than the applied input voltage. The switching waveforms observed during the operation of this circuit are shown in . Typical performance of this regulator is shown in .

Figure 16. 12-V Boost Regulator

8 Application And Implementation

8.1 Application Information

The LM2587 series of regulators are monolithic integrated circuits specifically designed for flyback, step-up (boost), and forward converter applications. Requiring a minimum number of external components, these regulators are cost effective and simple to use.

8.2 Typical Applications

8.2.1 Typical Boost Regulator Applications

Figure 18 through Figure 21 show four typical boost applications—one fixed and three using the adjustable version of the LM2587. Each drawing contains the part number(s) and manufacturer(s) for every component. For the fixed 12-V output application, the part numbers and manufacturers' names for the inductor are listed in . For applications with different output voltages, refer to the *Switchers Made Simple* software.

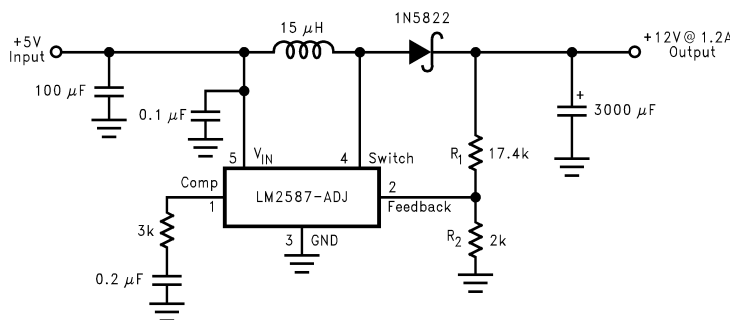

Figure 17. Boost Regulator

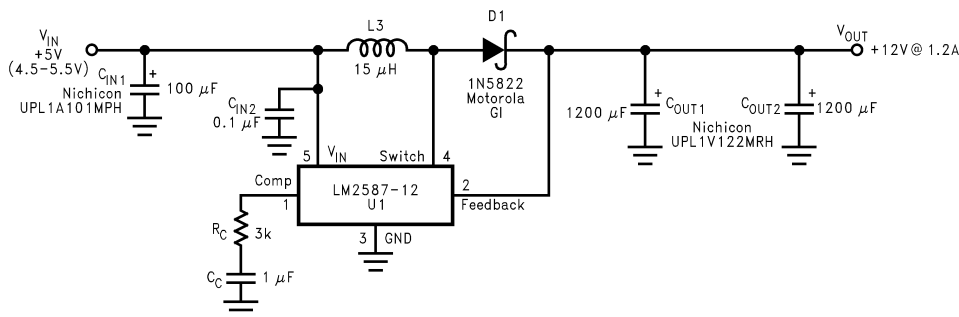

Figure 18. 5-V To 12-V Boost Regulator

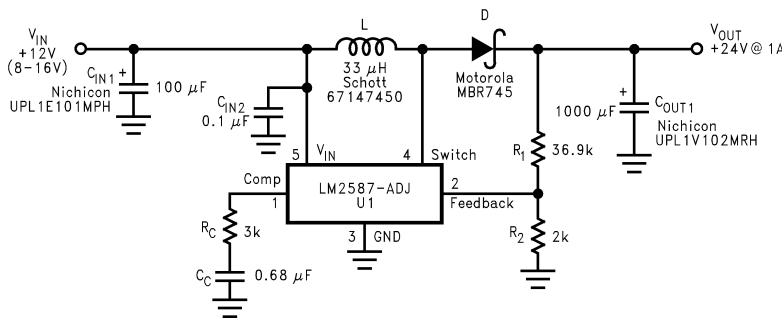
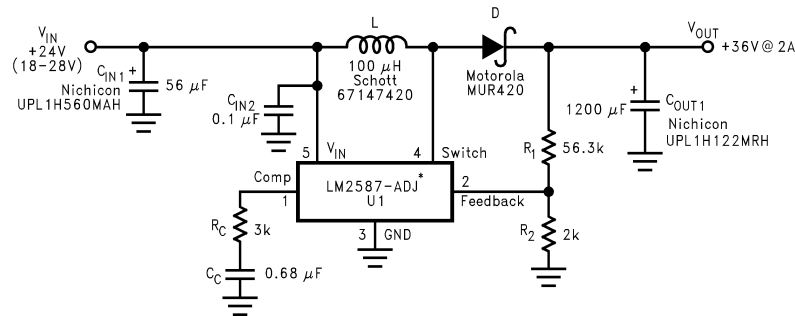
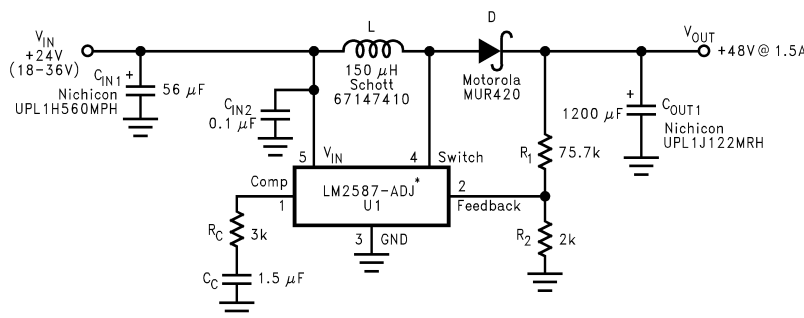

Figure 19. 12-V To 24-V Boost Regulator

Typical Applications (continued)

Figure 20. 24-V To 36-V Boost Regulator

*The LM2585 will require a heat sink in these applications. The size of the heat sink will depend on the maximum ambient temperature. To calculate the thermal resistance of the IC and the size of the heat sink needed, see

Figure 21. 24-V To 48-V Boost Regulator
8.2.2 Typical Flyback Regulator Applications

Figure 24 Figure 25 Figure 26 show six typical flyback applications, varying from single output to triple output. Each drawing contains the part number(s) and manufacturer(s) for every component except the transformer. For the transformer part numbers and manufacturers names, see the table in . For applications with different output voltages—requiring the LM2587-ADJ—or different output configurations that do not match the standard configurations, refer to the **Switchers Made Simple** software.

Typical Applications (continued)

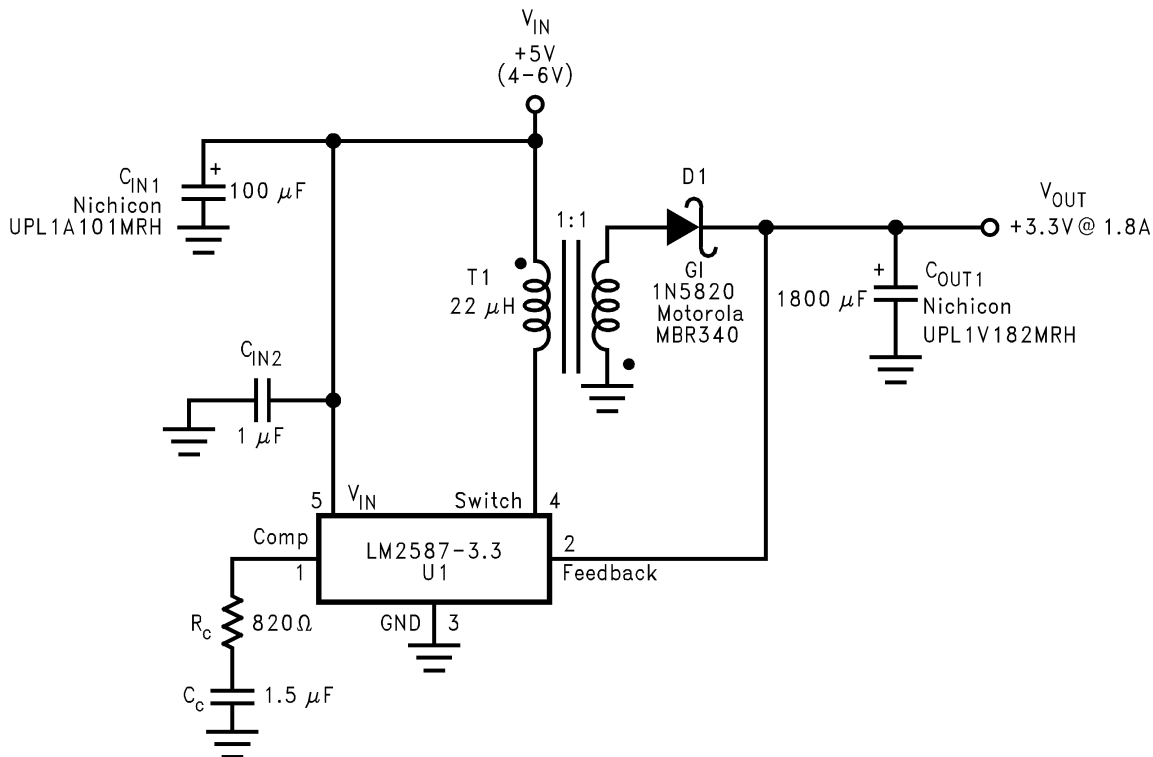

Figure 22. Single-Output Flyback Regulator

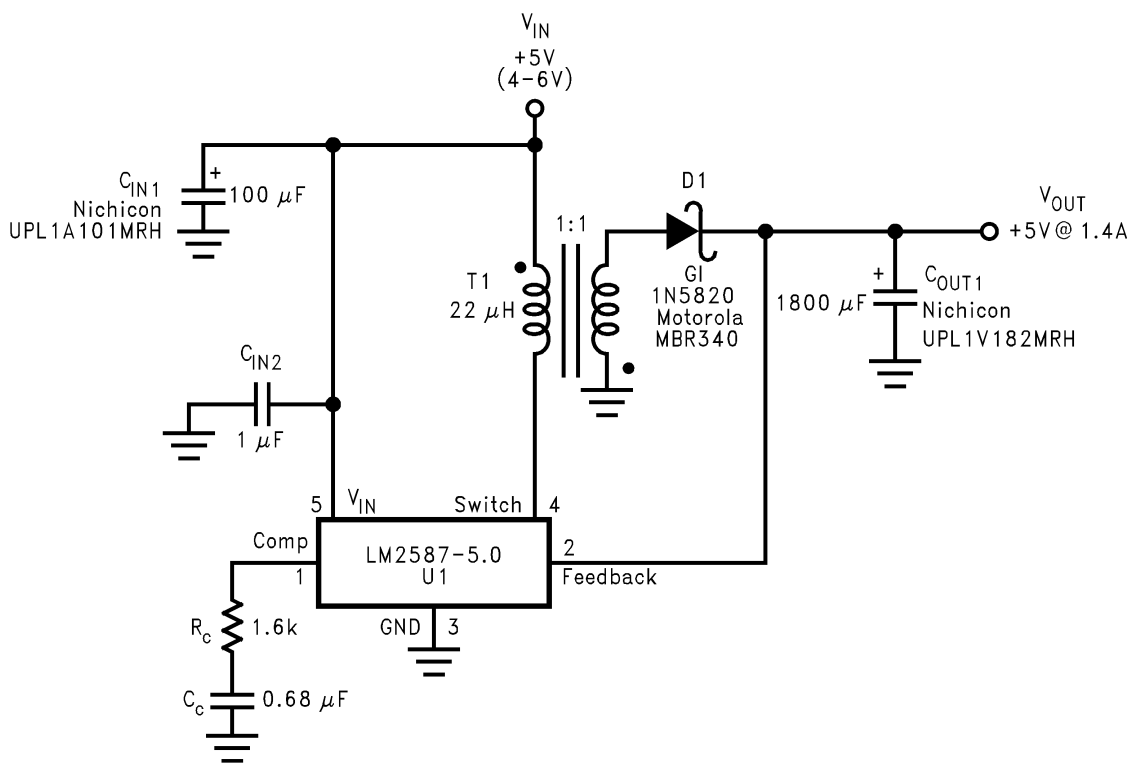

Figure 23. Single-Output Flyback Regulator

Typical Applications (continued)

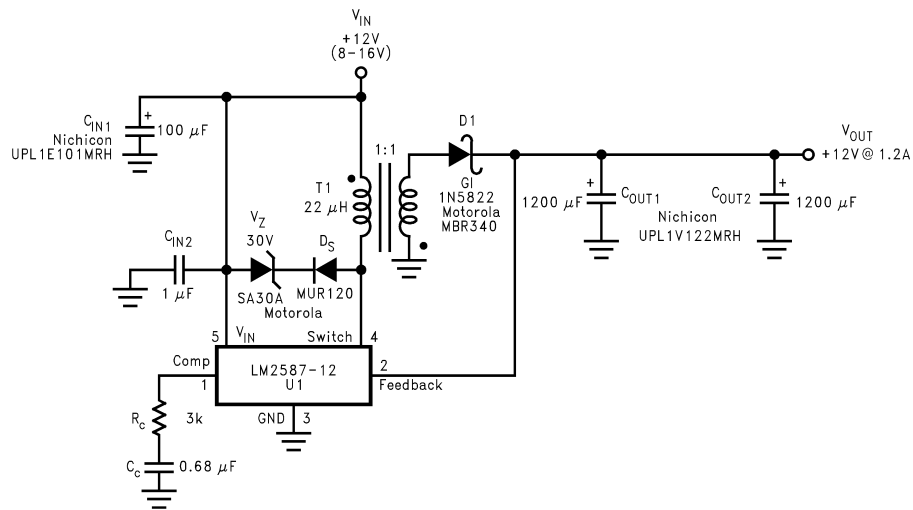

Figure 24. Single-Output Flyback Regulator

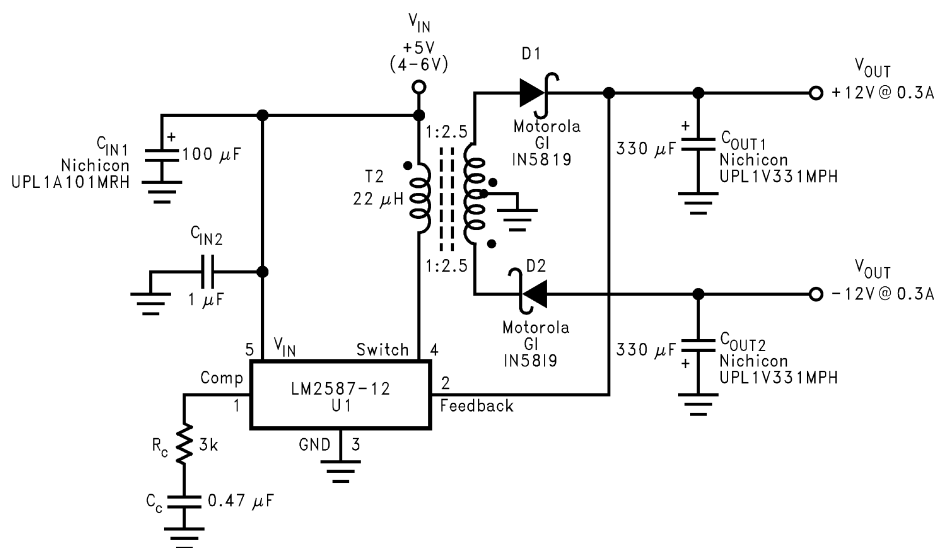

Figure 25. Dual-Output Flyback Regulator

Typical Applications (continued)

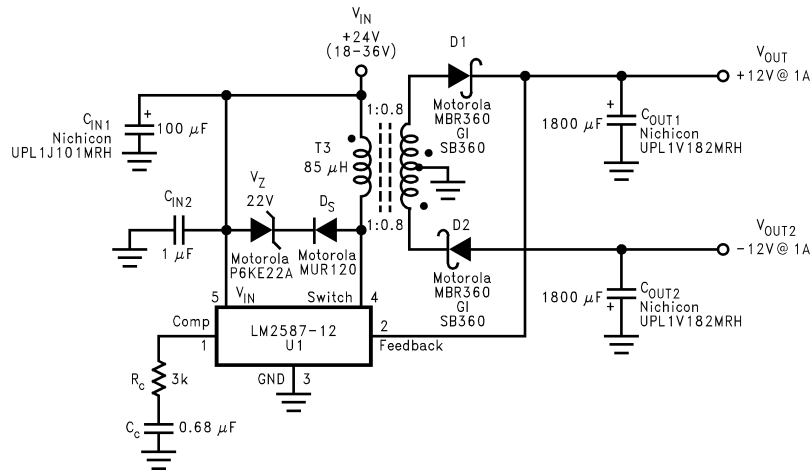

Figure 26. Dual-Output Flyback Regulator

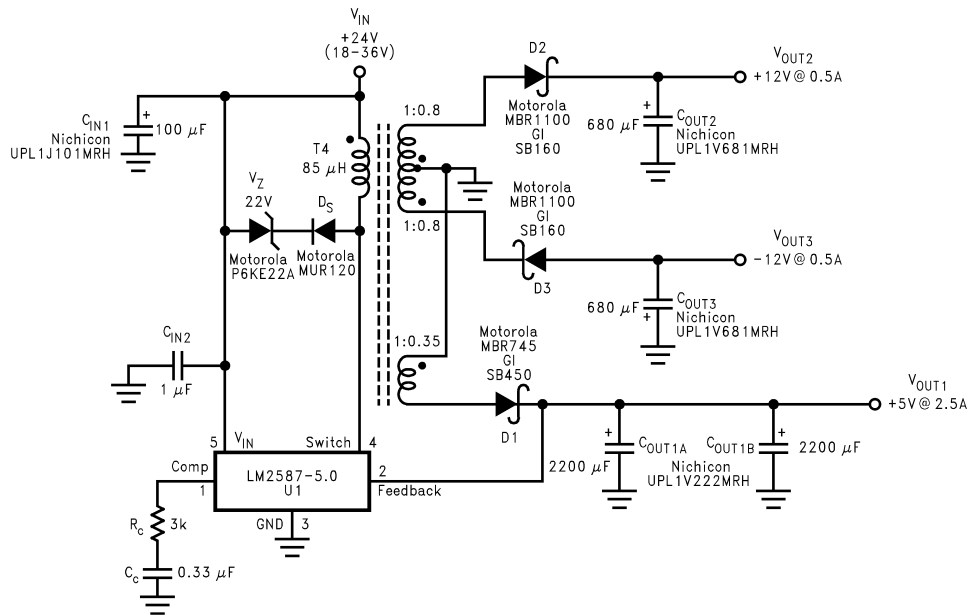

Figure 27. Triple-Output Flyback Regulator

Typical Applications (continued)

8.2.2.1 Transformer Selection (T)

lists the standard transformers available for flyback regulator applications. Included in the table are the turns ratio(s) for each transformer, as well as the output voltages, input voltage ranges, and the maximum load currents for each circuit.

Table 1. Transformer Selection Table

Applications			Figure 24	Figure 25	Figure 26	Figure 27
Transformers	T1	T1	T1	T2	T3	T4
V _{IN}	4V–6V	4V–6V	8V–16V	4V–6V	18V–36V	18V–36V
V _{OUT1}	3.3V	5V	12V	12V	12V	5V
I _{OUT1} (Max)	1.8A	1.4A	1.2A	0.3A	1A	2.5A
N ₁	1	1	1	2.5	0.8	0.35
V _{OUT2}				-12V	-12V	12V
I _{OUT2} (Max)				0.3A	1A	0.5A
N ₂				2.5	0.8	0.8
V _{OUT3}						-12V
I _{OUT3} (Max)						0.5A
N ₃						0.8

Table 2. Transformer Manufacturer Guide

Transformer Type	Manufacturers' Part Numbers					
	Coilcraft (1)	Coilcraft (1) Surface Mount	Pulse (2) Surface Mount	Pulse (2)	Renco (3)	Schott (4)
T5	Q4338-B	Q4437-B	PE-68413	—	RL-5532	67140890
T6	Q4339-B	Q4438-B	PE-68414	—	RL-5533	67140900
T7	S6000-A	S6057-A	—	PE-68482	RL-5751	26606

- (1) Coilcraft Inc. Phone: (800) 322-2645 www.coilcraft.com
- (2) Pulse Engineering Inc. Phone: (619) 674-8100 www.digikey.com
- (3) Renco Electronics Inc. Phone: (800) 645-5828 www.cdiweb.com/rengo
- (4) Schott Corp. Phone: (612) 475-1173 www.schottcorp.com/

8.2.2.2 Transformer Footprints

through Figure 58 show the footprints of each transformer, listed in .

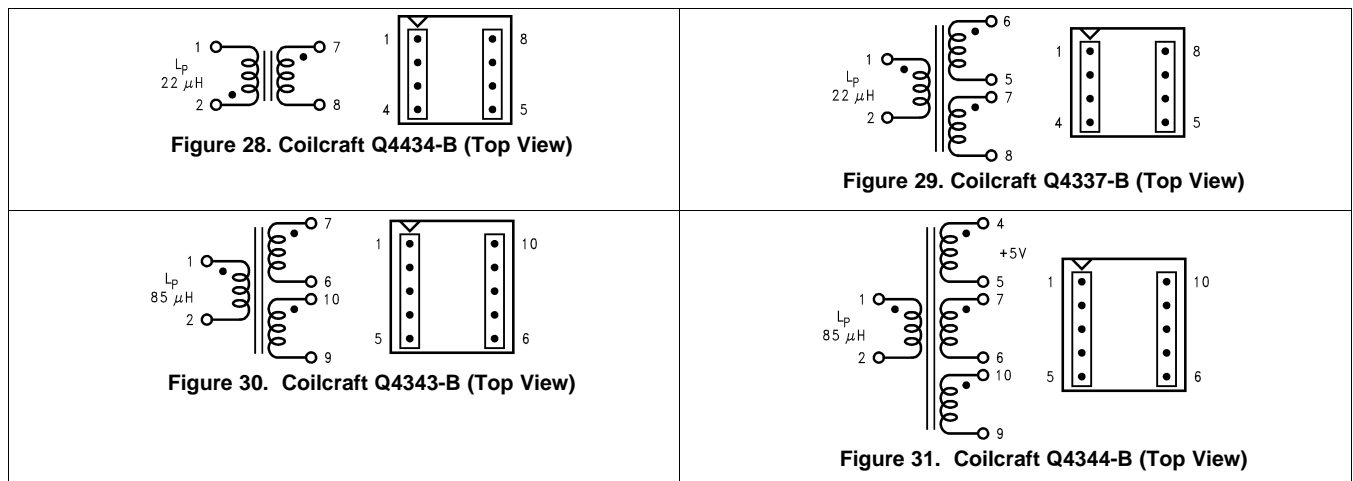

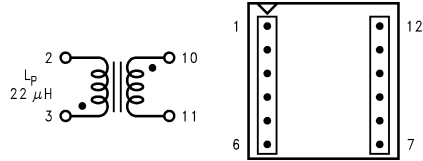

Figure 32. Coilcraft Q4435-B (Surface Mount) (Top View)

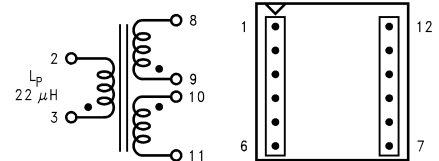

Figure 33. Coilcraft Q4436-B (Surface Mount) (Top View)

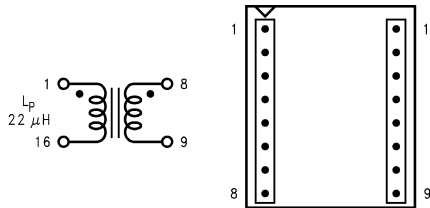

Figure 34. Pulse PE-68411 (Surface Mount) (Top View)

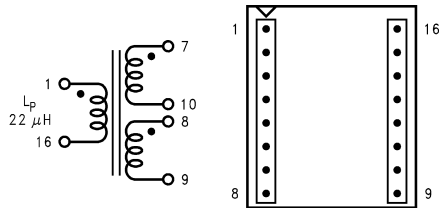

Figure 35. Pulse PE-68412 (Surface Mount) (Top View)

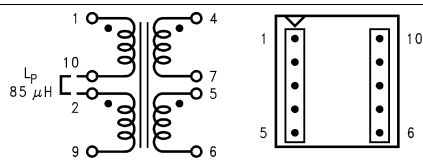

Figure 36. Pulse PE-68421 (Surface Mount) (Top View)

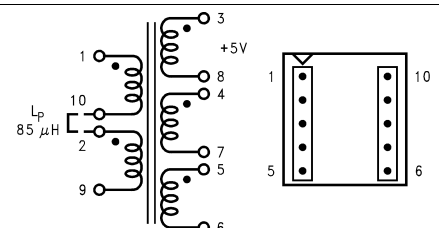

Figure 37. Pulse PE-68422 (Surface Mount) (Top View)

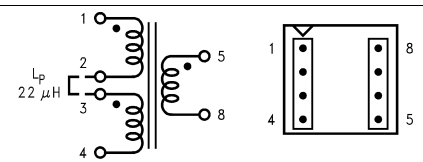

Figure 38. Renco RL-5530 (Top View)

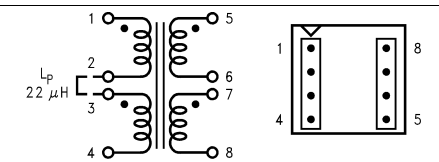

Figure 39. Renco RL-5531 (Top View)

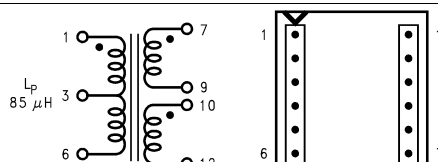

Figure 40. Renco RL-5534 (Top View)

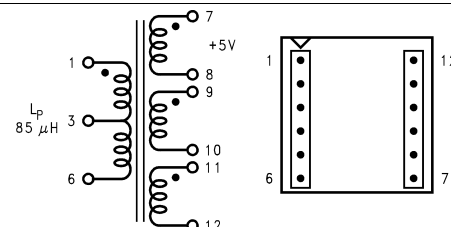

Figure 41. Renco RL-5535 (Top View)

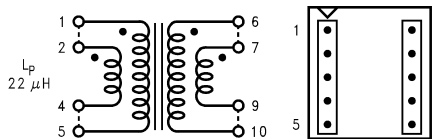

Figure 42. Schott 67141450 (Top View)

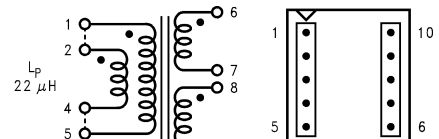

Figure 43. Schott 67140860 (Top View)

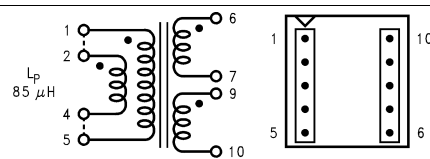

Figure 44. Schott 67140920 (Top View)

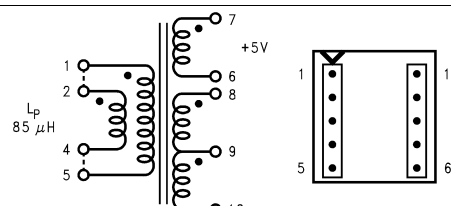

Figure 45. Schott 67140930 (Top View)

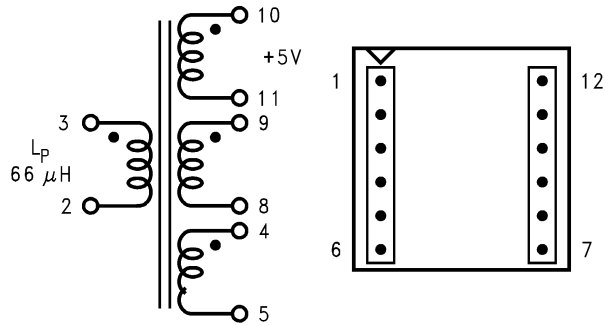

Figure 46. Coilcraft Q4437-B (Top View) (Surface Mount)

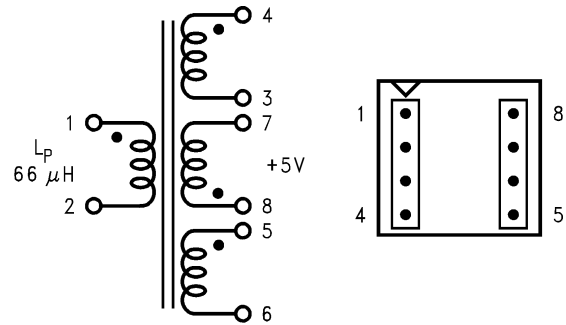

Figure 47. Coilcraft Q4338-B (Top View)

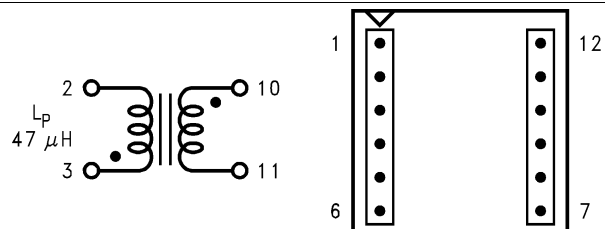

Figure 48. Coilcraft S6057-A (Top View) (Surface Mount)

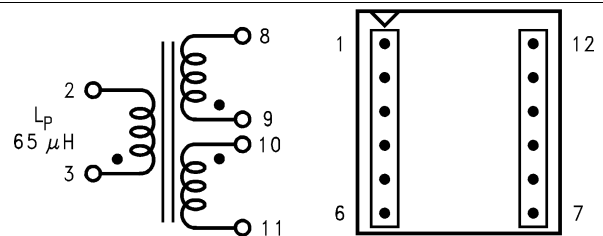

Figure 49. Coilcraft Q4438-B (Top View) (Surface Mount)

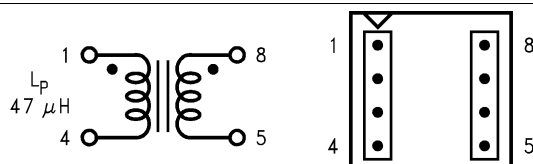

Figure 50. Pulse Pe-68482 (Top View)

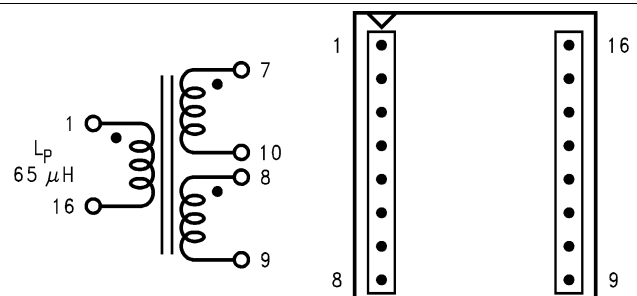

Figure 51. Pulse Pe-68414 (Top View) (Surface Mount)

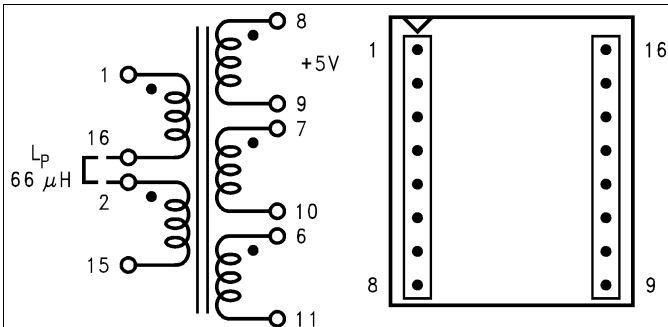

Figure 52. Pulse Pe-68413 (Top View) (Surface Mount)

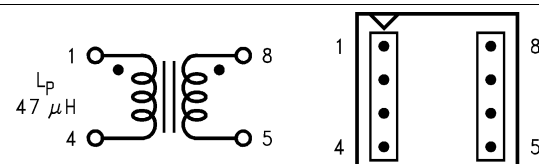

Figure 53. Renco RI-5751 (Top View)

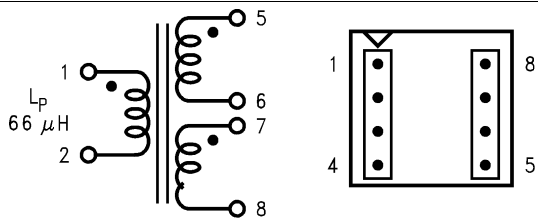

Figure 54. Renco RI-5533 (Top View)

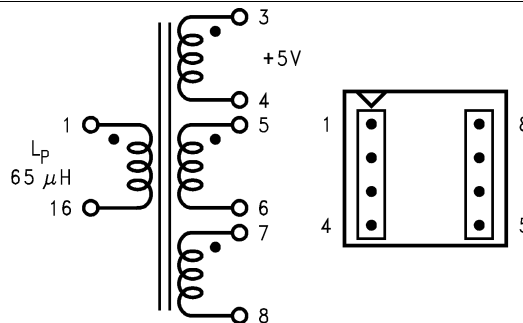

Figure 55. Renco RI-5532 (Top View)

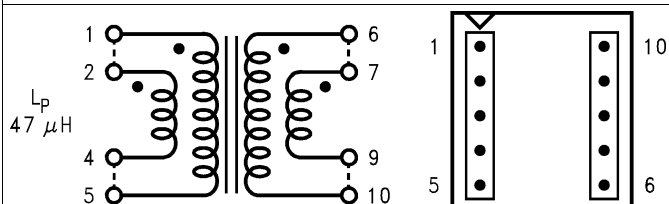

Figure 56. Schott 26606 (Top View)

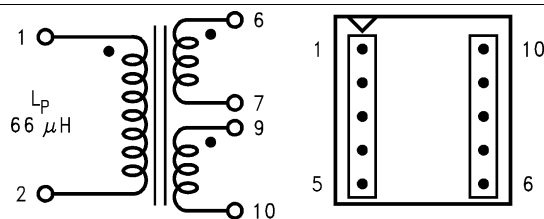

Figure 57. Schott 67140900 (Top View)

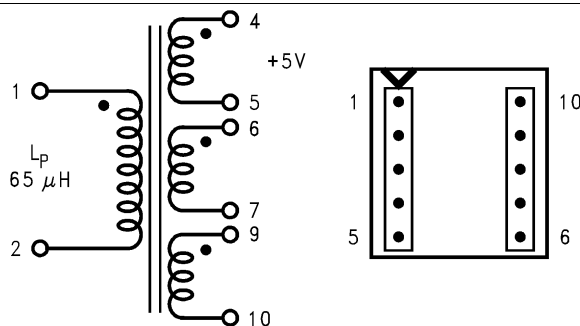

Figure 58. Schott 67140890 (Top View)

8.2.3 Design Requirements

Table 3 contains a table of standard inductors, by part number and corresponding manufacturer, for the fixed output regulator of Figure 18.

Table 3. Inductor Selection Table

Coilcraft ⁽¹⁾	Pulse ⁽²⁾	Renco ⁽³⁾	Schott ⁽⁴⁾
R4793-A	PE-53900	RL-5472-5	67146520

(1) Coilcraft Inc.: Phone: (800) 322-2645/1102 Silver Lake Road, Cary, IL 60013: Fax: (708) 639-1469

(2) Pulse Engineering Inc.: Phone: (619) 674-8100/12220 World Trade Drive, San Diego, CA 92128: Fax: (619) 674-8262

(3) Renco Electronics Inc.: Phone: (800) 645-5828/60 Jeffryn Blvd. East, Deer Park, NY 11729: Fax: (516) 586-5562

(4) Schott Corp.: Phone: (612) 475-1173/1000 Parkers Lane Road, Wayzata, MN 55391: Fax: (612) 475-1786

8.2.4 Detailed Design Procedure

8.2.4.1 Custom Design With Webench® Tools

Click [here](#) to create a custom design using the LM2587 device with the WEBENCH® Power Designer.

1. Start by entering the input voltage (V_{IN}), output voltage (V_{OUT}), and output current (I_{OUT}) requirements.
2. Optimize the design for key parameters such as efficiency, footprint, and cost using the optimizer dial.
3. Compare the generated design with other possible solutions from Texas Instruments.

The WEBENCH Power Designer provides a customized schematic along with a list of materials with real-time pricing and component availability.

In most cases, these actions are available:

- Run electrical simulations to see important waveforms and circuit performance
- Run thermal simulations to understand board thermal performance
- Export customized schematic and layout into popular CAD formats
- Print PDF reports for the design, and share the design with colleagues

Get more information about WEBENCH tools at www.ti.com/WEBENCH.

8.2.4.2 Programming Output Voltage (Selecting R_1 And R_2)

Referring to the adjustable regulator in Figure 17, the output voltage is programmed by the resistors R_1 and R_2 by the following formula:

$$V_{OUT} = V_{REF} (1 + R_1/R_2) \quad \text{where } V_{REF} = 1.23V \tag{1}$$

Resistors R_1 and R_2 divide the output voltage down so that it can be compared with the 1.23V internal reference. With R_2 between 1k and 5k, R_1 is:

$$R_1 = R_2 (V_{OUT}/V_{REF} - 1) \quad \text{where } V_{REF} = 1.23V \tag{2}$$

For best temperature coefficient and stability with time, use 1% metal film resistors.

8.2.4.3 Short Circuit Condition

Due to the inherent nature of boost regulators, when the output is shorted (see Figure 17), current flows directly from the input, through the inductor and the diode, to the output, bypassing the switch. The current limit of the switch *does not* limit the output current for the entire circuit. To protect the load and prevent damage to the switch, the current must be externally limited, either by the input supply or at the output with an external current limit circuit. The external limit should be set to the maximum switch current of the device, which is 5A.

In a flyback regulator application (Figure 59), using the standard transformers, the LM2587 will survive a short circuit to the main output. When the output voltage drops to 80% of its nominal value, the frequency will drop to 25 kHz. With a lower frequency, off times are larger. With the longer off times, the transformer can release all of its stored energy before the switch turns back on. Hence, the switch turns on initially with zero current at its collector. In this condition, the switch current limit will limit the peak current, saving the device.

8.2.4.4 Flyback Regulator Input Capacitors

A flyback regulator draws discontinuous pulses of current from the input supply. Therefore, there are two input capacitors needed in a flyback regulator; one for energy storage and one for filtering (see Figure 59). Both are required due to the inherent operation of a flyback regulator. To keep a stable or constant voltage supply to the LM2587, a storage capacitor ($\geq 100 \mu\text{F}$) is required. If the input source is a rectified DC supply and/or the application has a wide temperature range, the required rms current rating of the capacitor might be very large. This means a larger value of capacitance or a higher voltage rating will be needed of the input capacitor. The storage capacitor will also attenuate noise which may interfere with other circuits connected to the same input supply voltage.

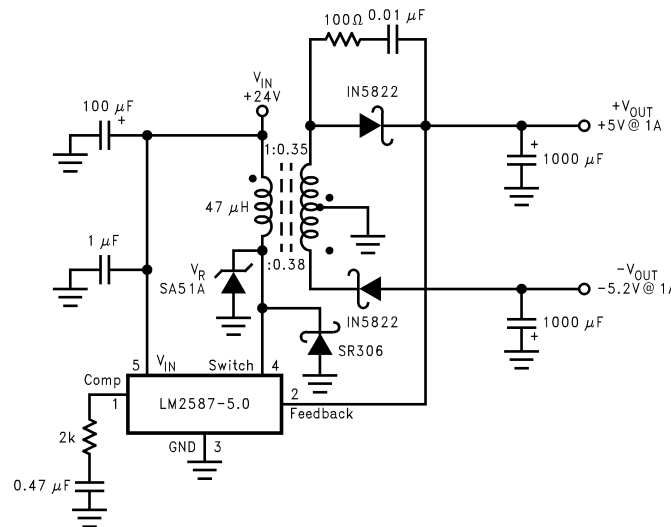

Figure 59. Flyback Regulator

In addition, a small bypass capacitor is required due to the noise generated by the input current pulses. To eliminate the noise, insert a $1.0 \mu\text{F}$ ceramic capacitor between V_{IN} and ground as close as possible to the device.

8.2.4.5 Switch Voltage Limits

In a flyback regulator, the maximum steady-state voltage appearing at the switch, when it is off, is set by the transformer turns ratio, N , the output voltage, V_{OUT} , and the maximum input voltage, $V_{IN}(\text{Max})$:

$$V_{SW(\text{OFF})} = V_{IN}(\text{Max}) + (V_{OUT} + V_F)/N \quad (3)$$

where V_F is the forward biased voltage of the output diode, and is 0.5V for Schottky diodes and 0.8V for ultra-fast recovery diodes (typically). In certain circuits, there exists a voltage spike, V_{LL} , superimposed on top of the steady-state voltage (see Figure 13, waveform A). Usually, this voltage spike is caused by the transformer leakage inductance and/or the output rectifier recovery time. To “clamp” the voltage at the switch from exceeding its maximum value, a transient suppressor in series with a diode is inserted across the transformer primary (as shown in the circuit on the front page and other flyback regulator circuits throughout the datasheet). The schematic in Figure 59 shows another method of clamping the switch voltage. A single voltage transient suppressor (the SA51A) is inserted at the switch pin. This method clamps the total voltage across the switch, not just the voltage across the primary.

If poor circuit layout techniques are used (see the Layout Guidelines section), negative voltage transients may appear on the Switch pin (pin 4). Applying a negative voltage (with respect to the IC's ground) to any monolithic IC pin causes erratic and unpredictable operation of that IC. This holds true for the LM2587 IC as well. When used in a flyback regulator, the voltage at the Switch pin (pin 4) can go negative when the switch turns on. The “ringing” voltage at the switch pin is caused by the output diode capacitance and the transformer leakage inductance forming a resonant circuit at the secondary(ies). The resonant circuit generates the “ringing” voltage, which gets reflected back through the transformer to the switch pin. There are two common methods to avoid this problem. One is to add an RC snubber around the output rectifier(s), as in Figure 59. The values of the resistor and the capacitor must be chosen so that the voltage at the Switch pin does not drop below -0.4V . The resistor may range in value between 10Ω and $1 \text{ k}\Omega$, and the capacitor will vary from $0.001 \mu\text{F}$ to $0.1 \mu\text{F}$. Adding a snubber will (slightly) reduce the efficiency of the overall circuit.

The other method to reduce or eliminate the “ringing” is to insert a Schottky diode clamp between pins 4 and 3 (ground), also shown in [Figure 59](#). This prevents the voltage at pin 4 from dropping below -0.4V . The reverse voltage rating of the diode must be greater than the switch off voltage.

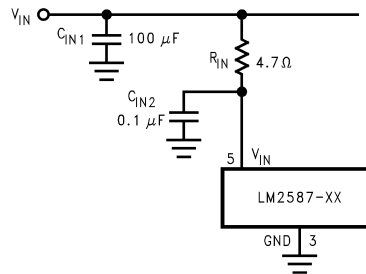

Figure 60. Input Line Filter

8.2.4.6 Output Voltage Limitations

The maximum output voltage of a boost regulator is the maximum switch voltage minus a diode drop. In a flyback regulator, the maximum output voltage is determined by the turns ratio, N , and the duty cycle, D , by the equation:

$$V_{\text{OUT}} \approx N \times V_{\text{IN}} \times D / (1 - D) \quad (4)$$

The duty cycle of a flyback regulator is determined by the following equation:

$$D = \frac{V_{\text{OUT}} + V_{\text{F}}}{N(V_{\text{IN}} - V_{\text{SAT}}) + V_{\text{OUT}} + V_{\text{F}}} \approx \frac{V_{\text{OUT}}}{N(V_{\text{IN}}) + V_{\text{OUT}}} \quad (5)$$

Theoretically, the maximum output voltage can be as large as desired—just keep increasing the turns ratio of the transformer. However, there exists some physical limitations that prevent the turns ratio, and thus the output voltage, from increasing to infinity. The physical limitations are capacitances and inductances in the LM2587 switch, the output diode(s), and the transformer—such as reverse recovery time of the output diode (mentioned above).

8.2.4.7 Noisy Input Line Condition)

A small, low-pass RC filter should be used at the input pin of the LM2587 if the input voltage has an unusual large amount of transient noise, such as with an input switch that bounces. The circuit in [Figure 60](#) demonstrates the layout of the filter, with the capacitor placed from the input pin to ground and the resistor placed between the input supply and the input pin. Note that the values of R_{IN} and C_{IN} shown in the schematic are good enough for most applications, but some readjusting might be required for a particular application. If efficiency is a major concern, replace the resistor with a small inductor (say $10 \mu\text{H}$ and rated at 100mA).

8.2.4.8 Stability

All current-mode controlled regulators can suffer from an instability, known as subharmonic oscillation, if they operate with a duty cycle above 50%. To eliminate subharmonic oscillations, a minimum value of inductance is required to ensure stability for all boost and flyback regulators. The minimum inductance is given by:

$$L(\text{Min}) = \frac{2.92 [(V_{\text{IN}}(\text{Min}) - V_{\text{SAT}}) \times (2D(\text{Max}) - 1)]}{1 - D(\text{Max})} (\mu\text{H})$$

where

- V_{SAT} is the switch saturation voltage and can be found in the Characteristic Curves. (6)

8.3 Additional Application Examples

8.3.1 Test Circuits

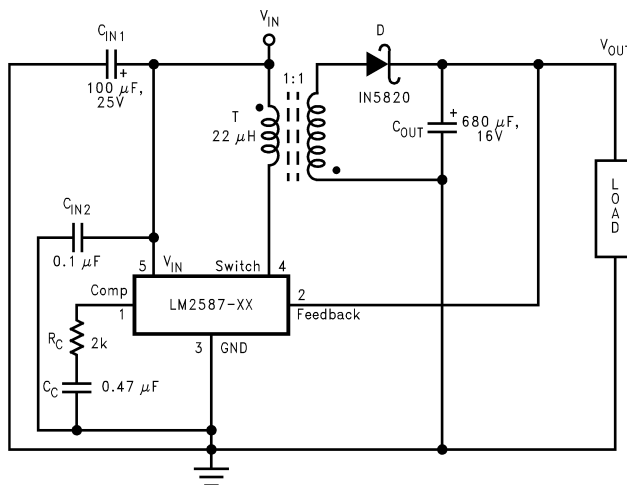

C_{IN1} —100 μ F, 25V Aluminum Electrolytic C_{IN2} —0.1 μ F Ceramic T —22 μ H, 1:1 Schott #67141450D—1N5820 C_{OUT} —680 μ F, 16V Aluminum Electrolytic C_C —0.47 μ F Ceramic R_C —2k

Figure 61. LM2587-3.3 and LM2587-5.0 Test Circuit

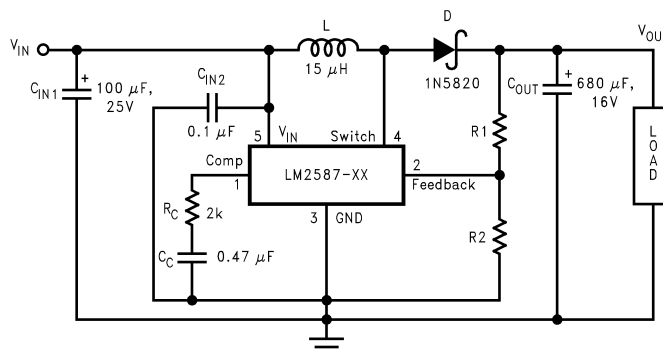

C_{IN1} —100 μ F, 25V Aluminum Electrolytic C_{IN2} —0.1 μ F Ceramic L —15 μ H, Renco #RL-5472-5D—1N5820 C_{OUT} —680 μ F, 16V Aluminum Electrolytic C_C —0.47 μ F Ceramic R_C —2k For 12V Devices: R_1 = Short (0 Ω) and R_2 = Open For ADJ Devices: R_1 = 48.75k, \pm 0.1% and R_2 = 5.62k, \pm 1%

Figure 62. LM2587-12 and LM2587-ADJ Test Circuit

9 Layout

9.1 Layout Guidelines

As in any switching regulator, layout is very important. Rapidly switching currents associated with wiring inductance generate voltage transients which can cause problems. For minimal inductance and ground loops, keep the length of the leads and traces as short as possible. Use single point grounding or ground plane construction for best results. Separate the signal grounds from the power grounds (as indicated in [Figure 63](#)). When using the adjustable version, physically locate the programming resistors as near the regulator IC as possible, to keep the sensitive feedback wiring short.

9.2 Layout Example

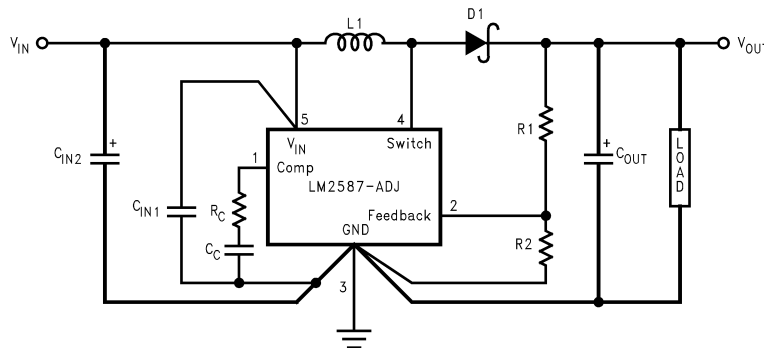

Figure 63. Circuit Board Layout

9.3 Heat Sink/Thermal Considerations

In many cases, no heat sink is required to keep the LM2587 junction temperature within the allowed operating range. For each application, to determine whether or not a heat sink will be required, the following must be identified:

- 1) Maximum ambient temperature (in the application).
- 2) Maximum regulator power dissipation (in the application).
- 3) Maximum allowed junction temperature (125°C for the LM2587). For a safe, conservative design, a temperature approximately 15°C cooler than the maximum junction temperature should be selected (110°C).
- 4) LM2587 package thermal resistances θ_{JA} and θ_{JC} (given in the Electrical Characteristics).

Total power dissipated (P_D) by the LM2587 can be estimated as follows:

Heat Sink/Thermal Considerations (continued)

Boost:

$$P_D = 0.15\Omega \times \left(\frac{I_{LOAD}}{1-D} \right)^2 \times D + \frac{I_{LOAD}}{50 \times (1-D)} \times D \times V_{IN}$$

Flyback:

$$P_D = 0.15\Omega \times \left(\frac{N \times \Sigma I_{LOAD}}{1-D} \right)^2 \times D + \frac{N \times \Sigma I_{LOAD}}{50 \times (1-D)} \times D \times V_{IN}$$

(7)

V_{IN} is the minimum input voltage, V_{OUT} is the output voltage, N is the transformer turns ratio, D is the duty cycle, and I_{LOAD} is the maximum load current (and ΣI_{LOAD} is the sum of the maximum load currents for multiple-output flyback regulators). The duty cycle is given by:

Boost:

$$D = \frac{V_{OUT} + V_F - V_{IN}}{V_{OUT} + V_F - V_{SAT}} \approx \frac{V_{OUT} - V_{IN}}{V_{OUT}}$$

Flyback:

$$D = \frac{V_{OUT} + V_F}{N(V_{IN} - V_{SAT}) + V_{OUT} + V_F} \approx \frac{V_{OUT}}{N(V_{IN}) + V_{OUT}}$$

where

- V_F is the forward biased voltage of the diode and is typically 0.5V for Schottky diodes and 0.8V for fast recovery diodes.
- V_{SAT} is the switch saturation voltage and can be found in the Characteristic Curves.

(8)

When no heat sink is used, the junction temperature rise is:

$$\Delta T_J = P_D \times \theta_{JA} \quad (9)$$

Adding the junction temperature rise to the maximum ambient temperature gives the actual operating junction temperature:

$$T_J = \Delta T_J + T_A \quad (10)$$

If the operating junction temperature exceeds the maximum junction temperature in item 3 above, then a heat sink is required. When using a heat sink, the junction temperature rise can be determined by the following:

$$\Delta T_J = P_D \times (\theta_{JC} + \theta_{Interface} + \theta_{Heat\ Sink}) \quad (11)$$

Again, the operating junction temperature will be:

$$T_J = \Delta T_J + T_A \quad (12)$$

As before, if the maximum junction temperature is exceeded, a larger heat sink is required (one that has a lower thermal resistance).

Included in the **Switchers Made Simple** design software is a more precise (non-linear) thermal model that can be used to determine junction temperature with different input-output parameters or different component values. It can also calculate the heat sink thermal resistance required to maintain the regulator junction temperature below the maximum operating temperature.

To further simplify the flyback regulator design procedure, TI is making available computer design software. Switchers Made Simple software is available on a (3½") diskette for IBM compatible computers from a TI sales office in your area or the TI WEBENCH Design Center team.

http://www.ti.com/ww/en/analog/webench/index.shtml?DCMP=hpa_sva_webench&HQS=webench-bb

Heat Sink/Thermal Considerations (continued)

9.3.1 European Magnetic Vendor Contacts

Please contact the following addresses for details of local distributors or representatives:

9.3.2 Coilcraft

21 Napier Place

Wardpark North Cumbernauld, Scotland G68 0LL Phone: +44 1236 730 595 Fax: +44 1236 730 627

9.3.3 Pulse Engineering

Dunmore Road

Tuam Co. Galway, Ireland Phone: +353 93 24 107 Fax: +353 93 24 459

10 デバイスおよびドキュメントのサポート

10.1 デバイス・サポート

10.1.1 デベロッパー・ネットワークの製品に関する免責事項

デベロッパー・ネットワークの製品またはサービスに関するTIの出版物は、単独またはTIの製品、サービスと一緒に提供される場合に関係なく、デベロッパー・ネットワークの製品またはサービスの適合性に関する是認、デベロッパー・ネットワークの製品またはサービスの是認の表明を意味するものではありません。

10.1.2 開発サポート

10.1.2.1 Webench® ツールによるカスタム設計

[ここをクリック](#)すると、WEBENCH® Power Designer により、LM2587 を使用するカスタム設計を作成できます。

1. 最初に、入力電圧(V_{IN})、出力電圧(V_{OUT})、出力電流(I_{OUT})の要件を入力します。
2. オプティマイザのダイヤルを使用して、効率、占有面積、コストなどの主要なパラメータについて設計を最適化します。
3. 生成された設計を、テキサス・インスツルメンツが提供する他の方式と比較します。

WEBENCH Power Designerでは、カスタマイズされた回路図と部品リストを、リアルタイムの価格と部品の在庫情報と併せて参照できます。

通常、次の操作を実行可能です。

- 電氣的なシミュレーションを実行し、重要な波形と回路の性能を確認する。
- 熱シミュレーションを実行し、基板の熱特性を把握する。
- カスタマイズされた回路図やレイアウトを、一般的なCADフォーマットで出力する。
- 設計のレポートをPDFで印刷し、設計を共有する。

WEBENCHツールの詳細は、www.ti.com/WEBENCHでご覧になれます。

10.2 ドキュメントの更新通知を受け取る方法

ドキュメントの更新についての通知を受け取るには、ti.comのデバイス製品フォルダを開いてください。右上の「アラートを受け取る」をクリックして登録すると、変更されたすべての製品情報に関するダイジェストを毎週受け取れます。変更の詳細については、修正されたドキュメントに含まれている改訂履歴をご覧ください。

10.3 コミュニティ・リソース

The following links connect to TI community resources. Linked contents are provided "AS IS" by the respective contributors. They do not constitute TI specifications and do not necessarily reflect TI's views; see TI's [Terms of Use](#).

TI E2E™ Online Community *TI's Engineer-to-Engineer (E2E) Community*. Created to foster collaboration among engineers. At e2e.ti.com, you can ask questions, share knowledge, explore ideas and help solve problems with fellow engineers.

Design Support *TI's Design Support* Quickly find helpful E2E forums along with design support tools and contact information for technical support.

10.4 商標

E2E is a trademark of Texas Instruments.

WEBENCH, Switchers Made Simple are registered trademarks of Texas Instruments.

All other trademarks are the property of their respective owners.

10.5 静電気放電に関する注意事項



すべての集積回路は、適切なESD保護方法を用いて、取扱いと保存を行うようにして下さい。

静電気放電はわずかな性能の低下から完全なデバイスの故障に至るまで、様々な損傷を与えます。高精度の集積回路は、損傷に対して敏感であり、極めてわずかなパラメータの変化により、デバイスに規定された仕様に適合しなくなる場合があります。

10.6 Glossary

[SLYZ022](#) — *TI Glossary*.

This glossary lists and explains terms, acronyms, and definitions.

11 メカニカル、パッケージ、および注文情報

以降のページには、メカニカル、パッケージ、および注文に関する情報が記載されています。この情報は、そのデバイスについて利用可能な最新のデータです。このデータは予告なく変更されることがあり、ドキュメントが改訂される場合もあります。本データシートのブラウザ版を使用されている場合は、画面左側の説明をご覧ください。

PACKAGING INFORMATION

Orderable part number	Status (1)	Material type (2)	Package Pins	Package qty Carrier	RoHS (3)	Lead finish/ Ball material (4)	MSL rating/ Peak reflow (5)	Op temp (°C)	Part marking (6)
LM2587S-12/NOPB	Active	Production	DDPAK/ TO-263 (KTT) 5	45 TUBE	ROHS Exempt	SN	Level-3-245C-168 HR	-40 to 125	LM2587S -12 P+
LM2587S-12/NOPB.B	Active	Production	DDPAK/ TO-263 (KTT) 5	45 TUBE	ROHS Exempt	SN	Level-3-245C-168 HR	-40 to 125	LM2587S -12 P+
LM2587S-3.3/NOPB	Active	Production	DDPAK/ TO-263 (KTT) 5	45 TUBE	ROHS Exempt	SN	Level-3-245C-168 HR	-40 to 125	LM2587S -3.3 P+
LM2587S-3.3/NOPB.B	Active	Production	DDPAK/ TO-263 (KTT) 5	45 TUBE	ROHS Exempt	SN	Level-3-245C-168 HR	-40 to 125	LM2587S -3.3 P+
LM2587S-5.0/NOPB	Active	Production	DDPAK/ TO-263 (KTT) 5	45 TUBE	ROHS Exempt	SN	Level-3-245C-168 HR	-40 to 125	LM2587S -5.0 P+
LM2587S-5.0/NOPB.B	Active	Production	DDPAK/ TO-263 (KTT) 5	45 TUBE	ROHS Exempt	SN	Level-3-245C-168 HR	-40 to 125	LM2587S -5.0 P+
LM2587S-ADJ/NOPB	Active	Production	DDPAK/ TO-263 (KTT) 5	45 TUBE	ROHS Exempt	SN	Level-3-245C-168 HR	-40 to 125	LM2587S -ADJ P+
LM2587S-ADJ/NOPB.B	Active	Production	DDPAK/ TO-263 (KTT) 5	45 TUBE	ROHS Exempt	SN	Level-3-245C-168 HR	-40 to 125	LM2587S -ADJ P+
LM2587SX-12/NOPB	Active	Production	DDPAK/ TO-263 (KTT) 5	500 LARGE T&R	ROHS Exempt	SN	Level-3-245C-168 HR	-40 to 125	LM2587S -12 P+
LM2587SX-12/NOPB.B	Active	Production	DDPAK/ TO-263 (KTT) 5	500 LARGE T&R	ROHS Exempt	SN	Level-3-245C-168 HR	-40 to 125	LM2587S -12 P+
LM2587SX-5.0/NOPB	Active	Production	DDPAK/ TO-263 (KTT) 5	500 LARGE T&R	ROHS Exempt	SN	Level-3-245C-168 HR	-40 to 125	LM2587S -5.0 P+
LM2587SX-5.0/NOPB.B	Active	Production	DDPAK/ TO-263 (KTT) 5	500 LARGE T&R	ROHS Exempt	SN	Level-3-245C-168 HR	-40 to 125	LM2587S -5.0 P+
LM2587SX-ADJ/NOPB	Active	Production	DDPAK/ TO-263 (KTT) 5	500 LARGE T&R	ROHS Exempt	SN	Level-3-245C-168 HR	-40 to 125	LM2587S -ADJ P+
LM2587SX-ADJ/NOPB.B	Active	Production	DDPAK/ TO-263 (KTT) 5	500 LARGE T&R	ROHS Exempt	SN	Level-3-245C-168 HR	-40 to 125	LM2587S -ADJ P+
LM2587T-12/NOPB	Active	Production	TO-220 (NDH) 5	45 TUBE	ROHS Exempt	SN	Level-1-NA-UNLIM	-40 to 125	LM2587T -12 P+
LM2587T-12/NOPB.B	Active	Production	TO-220 (NDH) 5	45 TUBE	ROHS Exempt	SN	Level-1-NA-UNLIM	-40 to 125	LM2587T -12 P+

Orderable part number	Status (1)	Material type (2)	Package Pins	Package qty Carrier	RoHS (3)	Lead finish/ Ball material (4)	MSL rating/ Peak reflow (5)	Op temp (°C)	Part marking (6)
LM2587T-3.3/NOPB	Active	Production	TO-220 (NDH) 5	45 TUBE	ROHS Exempt	SN	Level-1-NA-UNLIM	-40 to 125	LM2587T -3.3 P+
LM2587T-3.3/NOPB.B	Active	Production	TO-220 (NDH) 5	45 TUBE	ROHS Exempt	SN	Level-1-NA-UNLIM	-40 to 125	LM2587T -3.3 P+
LM2587T-5.0/NOPB	Active	Production	TO-220 (NDH) 5	45 TUBE	ROHS Exempt	SN	Level-1-NA-UNLIM	-40 to 125	LM2587T -5.0 P+
LM2587T-5.0/NOPB.B	Active	Production	TO-220 (NDH) 5	45 TUBE	ROHS Exempt	SN	Level-1-NA-UNLIM	-40 to 125	LM2587T -5.0 P+
LM2587T-ADJ/NOPB	Active	Production	TO-220 (NDH) 5	45 TUBE	ROHS Exempt	SN	Level-1-NA-UNLIM	-40 to 125	LM2587T -ADJ P+
LM2587T-ADJ/NOPB.B	Active	Production	TO-220 (NDH) 5	45 TUBE	ROHS Exempt	SN	Level-1-NA-UNLIM	-40 to 125	LM2587T -ADJ P+

(1) **Status:** For more details on status, see our [product life cycle](#).

(2) **Material type:** When designated, preproduction parts are prototypes/experimental devices, and are not yet approved or released for full production. Testing and final process, including without limitation quality assurance, reliability performance testing, and/or process qualification, may not yet be complete, and this item is subject to further changes or possible discontinuation. If available for ordering, purchases will be subject to an additional waiver at checkout, and are intended for early internal evaluation purposes only. These items are sold without warranties of any kind.

(3) **RoHS values:** Yes, No, RoHS Exempt. See the [TI RoHS Statement](#) for additional information and value definition.

(4) **Lead finish/Ball material:** Parts may have multiple material finish options. Finish options are separated by a vertical ruled line. Lead finish/Ball material values may wrap to two lines if the finish value exceeds the maximum column width.

(5) **MSL rating/Peak reflow:** The moisture sensitivity level ratings and peak solder (reflow) temperatures. In the event that a part has multiple moisture sensitivity ratings, only the lowest level per JEDEC standards is shown. Refer to the shipping label for the actual reflow temperature that will be used to mount the part to the printed circuit board.

(6) **Part marking:** There may be an additional marking, which relates to the logo, the lot trace code information, or the environmental category of the part.

Multiple part markings will be inside parentheses. Only one part marking contained in parentheses and separated by a "~" will appear on a part. If a line is indented then it is a continuation of the previous line and the two combined represent the entire part marking for that device.

Important Information and Disclaimer: The information provided on this page represents TI's knowledge and belief as of the date that it is provided. TI bases its knowledge and belief on information provided by third parties, and makes no representation or warranty as to the accuracy of such information. Efforts are underway to better integrate information from third parties. TI has taken and continues to take reasonable steps to provide representative

and accurate information but may not have conducted destructive testing or chemical analysis on incoming materials and chemicals. TI and TI suppliers consider certain information to be proprietary, and thus CAS numbers and other limited information may not be available for release.

In no event shall TI's liability arising out of such information exceed the total purchase price of the TI part(s) at issue in this document sold by TI to Customer on an annual basis.

TAPE AND REEL INFORMATION

QUADRANT ASSIGNMENTS FOR PIN 1 ORIENTATION IN TAPE

*All dimensions are nominal

Device	Package Type	Package Drawing	Pins	SPQ	Reel Diameter (mm)	Reel Width W1 (mm)	A0 (mm)	B0 (mm)	K0 (mm)	P1 (mm)	W (mm)	Pin1 Quadrant
LM2587SX-12/NOPB	DDPAK/TO-263	KTT	5	500	330.0	24.4	10.75	14.85	5.0	16.0	24.0	Q2
LM2587SX-5.0/NOPB	DDPAK/TO-263	KTT	5	500	330.0	24.4	10.75	14.85	5.0	16.0	24.0	Q2
LM2587SX-ADJ/NOPB	DDPAK/TO-263	KTT	5	500	330.0	24.4	10.75	14.85	5.0	16.0	24.0	Q2

TAPE AND REEL BOX DIMENSIONS

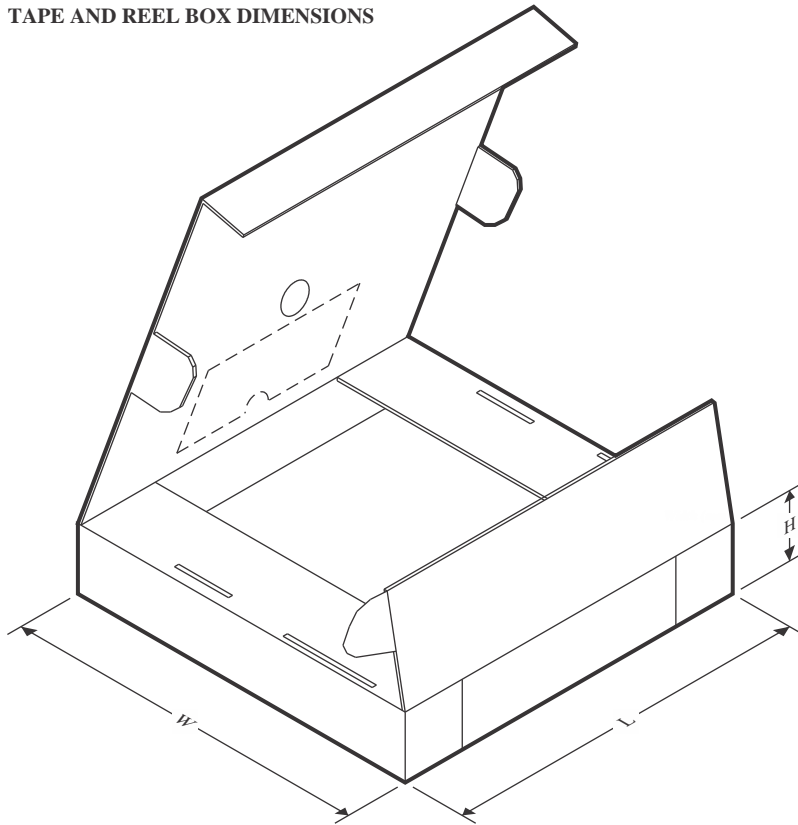

*All dimensions are nominal

Device	Package Type	Package Drawing	Pins	SPQ	Length (mm)	Width (mm)	Height (mm)
LM2587SX-12/NOPB	DDPAK/TO-263	KTT	5	500	356.0	356.0	45.0
LM2587SX-5.0/NOPB	DDPAK/TO-263	KTT	5	500	356.0	356.0	45.0
LM2587SX-ADJ/NOPB	DDPAK/TO-263	KTT	5	500	356.0	356.0	45.0

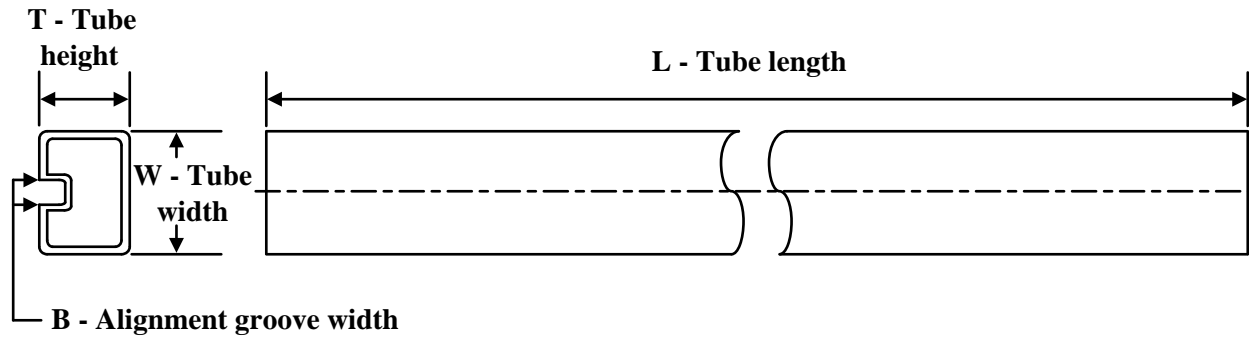
TUBE

*All dimensions are nominal

Device	Package Name	Package Type	Pins	SPQ	L (mm)	W (mm)	T (µm)	B (mm)
LM2587S-12/NOPB	KTT	TO-263	5	45	502	25	8204.2	9.19
LM2587S-12/NOPB.B	KTT	TO-263	5	45	502	25	8204.2	9.19
LM2587S-3.3/NOPB	KTT	TO-263	5	45	502	25	8204.2	9.19
LM2587S-3.3/NOPB.B	KTT	TO-263	5	45	502	25	8204.2	9.19
LM2587S-5.0/NOPB	KTT	TO-263	5	45	502	25	8204.2	9.19
LM2587S-5.0/NOPB.B	KTT	TO-263	5	45	502	25	8204.2	9.19
LM2587S-ADJ/NOPB	KTT	TO-263	5	45	502	25	8204.2	9.19
LM2587S-ADJ/NOPB.B	KTT	TO-263	5	45	502	25	8204.2	9.19
LM2587T-12/NOPB	NDH	TO-220	5	45	502	30	30048.2	10.74
LM2587T-12/NOPB.B	NDH	TO-220	5	45	502	30	30048.2	10.74
LM2587T-3.3/NOPB	NDH	TO-220	5	45	502	30	30048.2	10.74
LM2587T-3.3/NOPB.B	NDH	TO-220	5	45	502	30	30048.2	10.74
LM2587T-5.0/NOPB	NDH	TO-220	5	45	502	30	30048.2	10.74
LM2587T-5.0/NOPB.B	NDH	TO-220	5	45	502	30	30048.2	10.74
LM2587T-ADJ/NOPB	NDH	TO-220	5	45	502	30	30048.2	10.74
LM2587T-ADJ/NOPB.B	NDH	TO-220	5	45	502	30	30048.2	10.74

NDH0005D

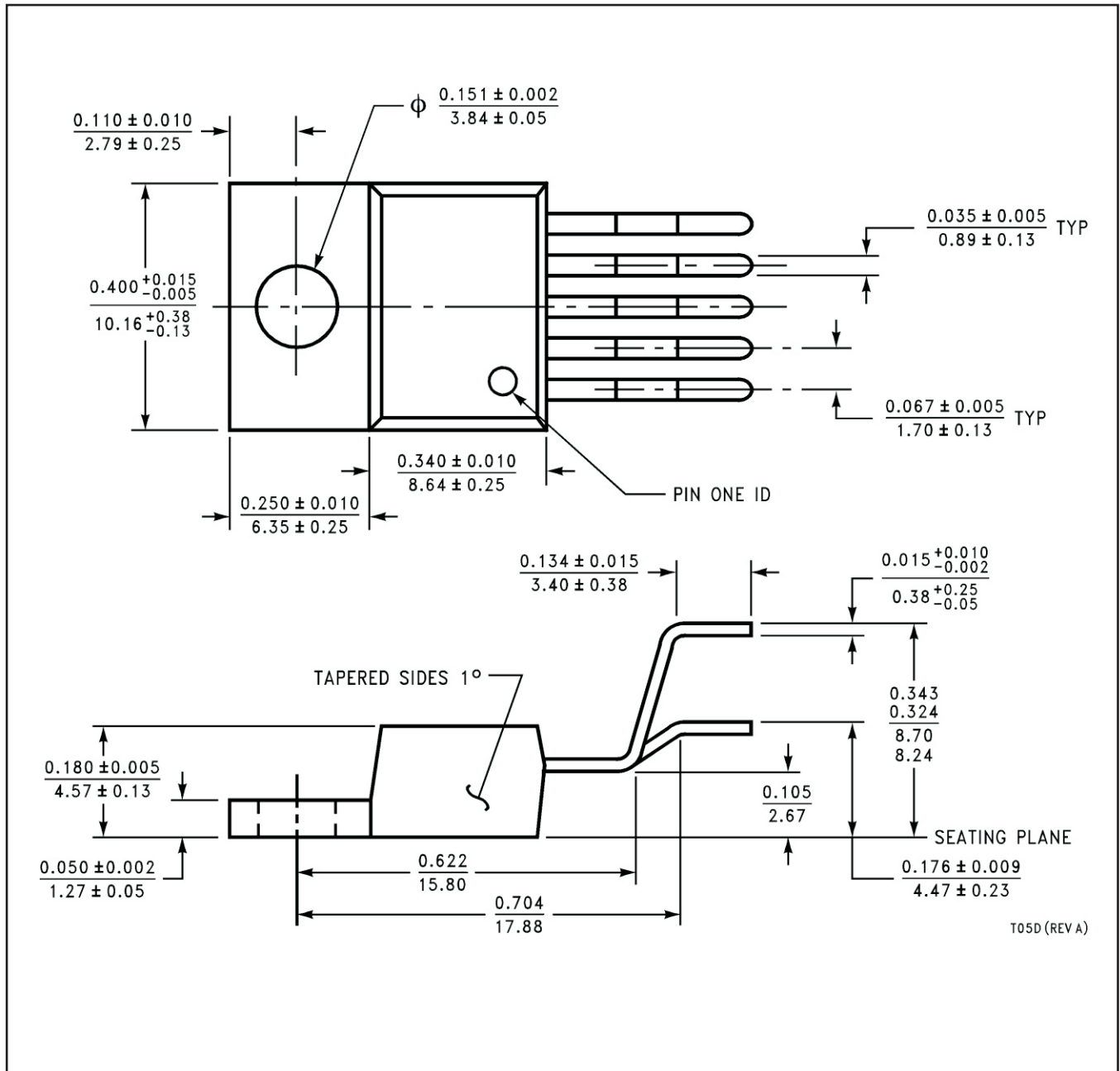

T05D (REV A)

KTT0005B

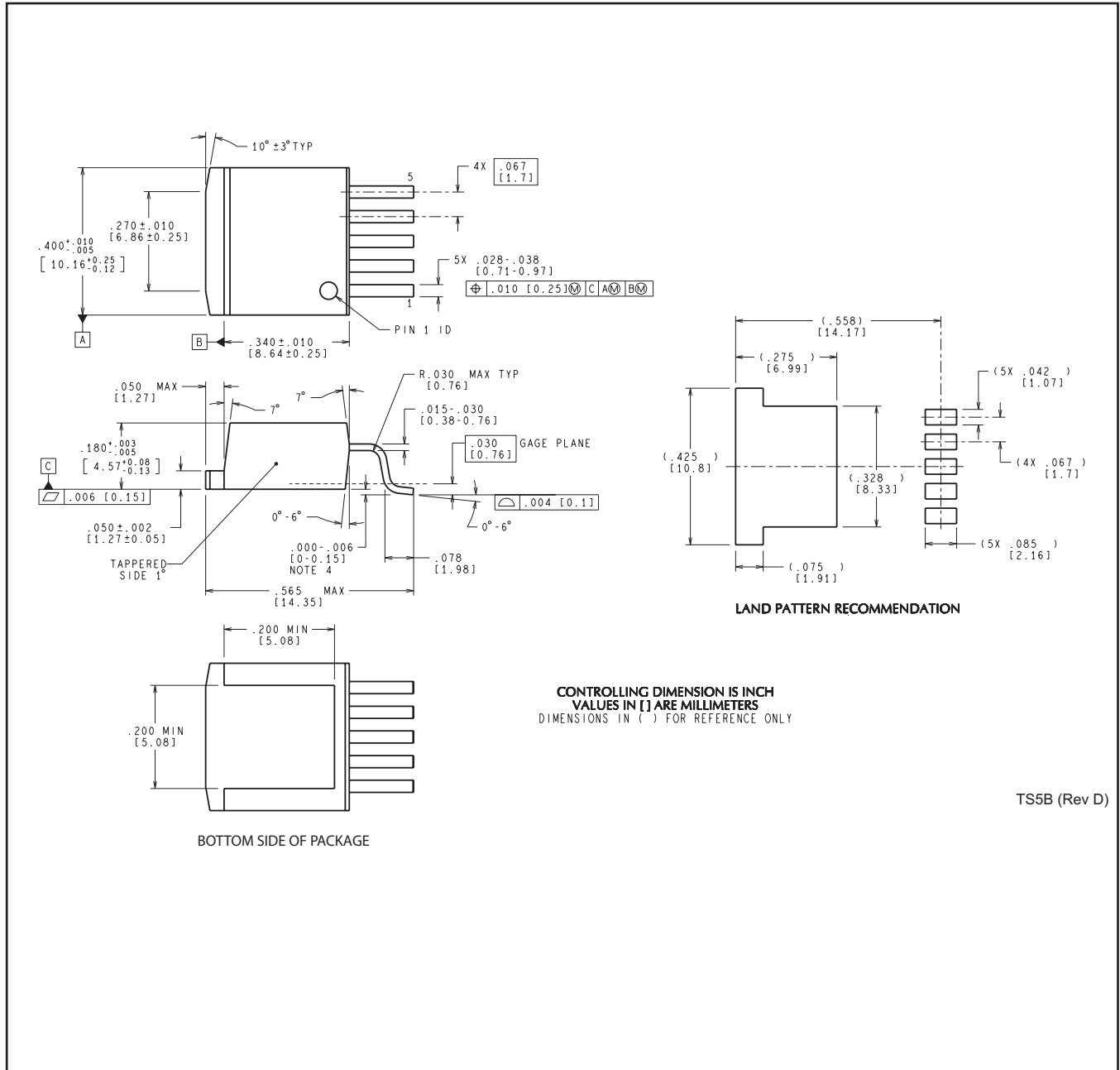

TS5B (Rev D)

重要なお知らせと免責事項

TI は、技術データと信頼性データ(データシートを含みます)、設計リソース(リファレンス デザインを含みます)、アプリケーションや設計に関する各種アドバイス、Web ツール、安全性情報、その他のリソースを、欠陥が存在する可能性のある「現状のまま」提供しており、商品性および特定目的に対する適合性の黙示保証、第三者の知的財産権の非侵害保証を含むいかなる保証も、明示的または黙示的にかかわらず拒否します。

これらのリソースは、TI 製品を使用する設計の経験を積んだ開発者への提供を意図したものです。(1) お客様のアプリケーションに適した TI 製品の選定、(2) お客様のアプリケーションの設計、検証、試験、(3) お客様のアプリケーションに該当する各種規格や、その他のあらゆる安全性、セキュリティ、規制、または他の要件への確実な適合に関する責任を、お客様のみが単独で負うものとし、

上記の各種リソースは、予告なく変更される可能性があります。これらのリソースは、リソースで説明されている TI 製品を使用するアプリケーションの開発の目的でのみ、TI はその使用をお客様に許諾します。これらのリソースに関して、他の目的で複製することや掲載することは禁止されています。TI や第三者の知的財産権のライセンスが付与されている訳ではありません。お客様は、これらのリソースを自身で使用した結果発生するあらゆる申し立て、損害、費用、損失、責任について、TI およびその代理人を完全に補償するものとし、TI は一切の責任を拒否します。

TI の製品は、[TI の販売条件](#)、[TI の総合的な品質ガイドライン](#)、[ti.com](#) または TI 製品などに関連して提供される他の適用条件に従い提供されます。TI がこれらのリソースを提供することは、適用される TI の保証または他の保証の放棄の拡大や変更を意味するものではありません。TI がカスタム、またはカスタマー仕様として明示的に指定していない限り、TI の製品は標準的なカタログに掲載される汎用機器です。

お客様がいかなる追加条項または代替条項を提案する場合も、TI はそれらに異議を唱え、拒否します。

Copyright © 2026, Texas Instruments Incorporated

最終更新日 : 2025 年 10 月