

## LM4051-N 高精度マイクロパワー・シャント型基準電圧

### 1 特長

- 出力コンデンサ不要
- 容量性負荷に対して安定
- 1.225Vと可変を選択できる逆方向降伏電圧
- 主な仕様
  - 出力電圧の許容誤差(Aグレード、25°C):  $\pm 0.1\%$  (最大値)
  - 出力ノイズ(10Hz~10kHz): 20 $\mu$ V rms
  - 動作電流範囲: 60 $\mu$ A~12mA
  - 産業用温度範囲: -40°C~+85°C
  - 拡張温度範囲: -40°C~+125°C
  - 温度ドリフト係数: 50ppm/°C (最大値)

### 2 アプリケーション

- バッテリー駆動のポータブル機器
- データ・アクイジション・システム
- 計測機器
- プロセス制御
- エネルギー管理
- 車載用および産業用
- 高精度のオーディオ・コンポーネント
- 基地局
- バッテリー・チャージャ
- 医療用機器
- 通信

### 3 概要

LM4051-N高精度基準電圧は、超小型(3mm×1.3mm)のSOT-23表面実装パッケージで供給され、スペースの制約が厳しいアプリケーションに理想的です。LM4051-Nは先進の設計により、いかなる容量性負荷に対しても安定性が確保されている一方で、安定化コンデンサを外付けする必要がなく、使いやすい製品になっています。逆降伏電圧として固定(1.225V)と可変を選択できるため、さらに設計の労力が軽減されます。LM4051-1.2およびLM4051-ADJの最小動作電流は60 $\mu$ Aです。最大動作電流は、どちらのバージョンも12mAです。

LM4051-Nには、A、B、Cの3つのグレードがあります。最も精度の高いAグレードのデバイスは初期精度が0.1%、Bグレードは0.2%、Cグレードは0.5%で、いずれも-40°C~125°Cの範囲で50ppm/°Cの温度ドリフト係数を保証しています。

LM4051-Nは、ウェハー・ソート時にヒューズとツェナーザップを使用して逆方向降伏電圧(基準電圧)を微調整することで、最も高い精度のグレードの場合、 $\pm 0.1\%$ 未満(Aグレード、25°C)の精度を確保しています。

#### 製品情報<sup>(1)</sup>

型番	パッケージ	本体サイズ(公称)
LM4051-N	SOT-23 (3)	3.00mm×1.30mm

(1) 利用可能なすべてのパッケージについては、このデータシートの末尾にある注文情報を参照してください。

1.2V<sub>REF</sub>の概略回路図

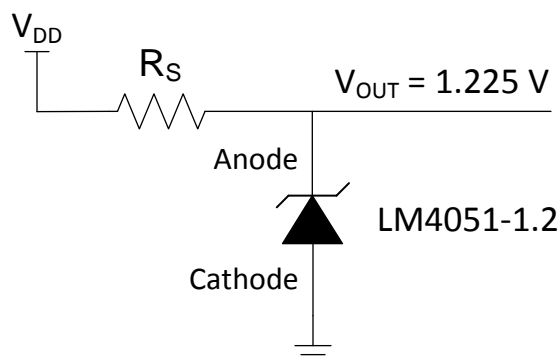

可変基準電圧の概略回路図

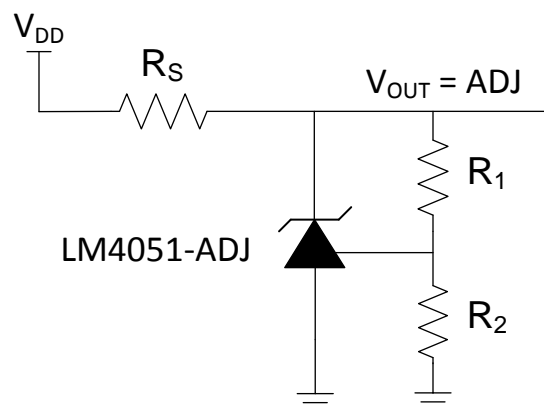

## 目次

1	特長	1	8.3	Feature Description	10
2	アプリケーション	1	8.4	Device Functional Modes	10
3	概要	1	<b>9</b>	<b>Application and Implementation</b>	<b>11</b>
4	改訂履歴	2	9.1	Application Information	11
<b>5</b>	<b>Pin Configuration and Functions</b>	<b>3</b>	9.2	Typical Applications	12
<b>6</b>	<b>Specifications</b>	<b>3</b>	9.3	System Examples	14
6.1	Absolute Maximum Ratings	3	<b>10</b>	<b>Power Supply Recommendations</b>	<b>18</b>
6.2	ESD Ratings	3	<b>11</b>	<b>Layout</b>	<b>18</b>
6.3	Recommended Operating Conditions	4	11.1	Layout Guidelines	18
6.4	Thermal Information	4	11.2	Layout Example	18
6.5	LM4051-1.2 Electrical Characteristics	4	<b>12</b>	<b>デバイスおよびドキュメントのサポート</b>	<b>19</b>
6.6	LM4051-ADJ Electrical Characteristics	5	12.1	ドキュメントの更新通知を受け取る方法	19
6.7	Typical Characteristics	7	12.2	コミュニティ・リソース	19
<b>7</b>	<b>Parameter Measurement Information</b>	<b>9</b>	12.3	商標	19
<b>8</b>	<b>Detailed Description</b>	<b>10</b>	12.4	静電気放電に関する注意事項	19
8.1	Overview	10	12.5	Glossary	19
8.2	Functional Block Diagram	10	<b>13</b>	<b>メカニカル、パッケージ、および注文情報</b>	<b>19</b>

## 4 改訂履歴

資料番号末尾の英字は改訂を表しています。その改訂履歴は英語版に準じています。

### Revision C (March 2005) から Revision D に変更

Page

• 「製品情報」表、「製品比較」表、「ESD定格」表、「機能説明」セクション、「デバイスの機能モード」セクション、「アプリケーションと実装」セクション、「電源に関する推奨事項」セクション、「レイアウト」セクション、「デバイスおよびドキュメントのサポート」セクション、「メカニカル、パッケージ、および注文情報」セクションを追加	1
--	---

## 5 Pin Configuration and Functions

**DBZ Package**  
1.2-V, 3-Pin SOT-23  
Top View

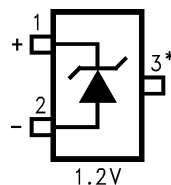

\* This pin must be left floating or connected to pin 2.

**DBZ Package**  
Adjustable, 3-Pin SOT-23  
Top View

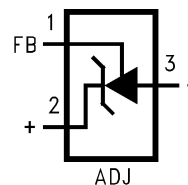

### Pin Functions

PIN			I/O	DESCRIPTION
NAME	1.2 V	ADJ		
Anode	2	3	O	Shunt Current/Voltage input
Cathode	1	2	I/O	Common pin, normally connected to ground
NC	3	-	-	Must float or connect to anode
FB	-	1	I	Threshold relative to cathode

## 6 Specifications

### 6.1 Absolute Maximum Ratings

over operating free-air temperature range (unless otherwise noted)<sup>(1)</sup>

	MIN	MAX	UNIT
Reverse current		20	mA
Forward current		10	mA
Maximum output voltage (LM4051-ADJ)		15	V
Power dissipation ( $T_A = 25^\circ\text{C}$ ) <sup>(2)</sup> M3 package		280	mW
Lead temperature M3 packages	Vapor phase (60 seconds)	215	°C
	Infrared (15 seconds)	220	
Storage temperature, $T_{\text{stg}}$	-65	150	°C

- (1) Stresses beyond those listed under *Absolute Maximum Ratings* may cause permanent damage to the device. These are stress ratings only, which do not imply functional operation of the device at these or any other conditions beyond those indicated under *Recommended Operating Conditions*. Exposure to absolute-maximum-rated conditions for extended periods may affect device reliability.
- (2) The maximum power dissipation must be derated at elevated temperatures and is dictated by  $T_{\text{Jmax}}$  (maximum junction temperature),  $\theta_{\text{JA}}$  (junction to ambient thermal resistance), and  $T_A$  (ambient temperature). The maximum allowable power dissipation at any temperature is  $P_{\text{Dmax}} = (T_{\text{Jmax}} - T_A) / \theta_{\text{JA}}$  or the number given in the *Absolute Maximum Ratings*, whichever is lower. For the LM4051-N,  $T_{\text{Jmax}} = 125^\circ\text{C}$ , and the typical thermal resistance ( $\theta_{\text{JA}}$ ), when board mounted, is  $280^\circ\text{C/W}$  for the SOT-23 package.

### 6.2 ESD Ratings

	VALUE	UNIT
$V_{\text{(ESD)}}$ Electrostatic discharge	Human-body model (HBM), per ANSI/ESDA/JEDEC JS-001 <sup>(1)(2)</sup>	±2000
	Machine model (MM) <sup>(3)</sup>	200

- (1) JEDEC document JEP155 states that 500-V HBM allows safe manufacturing with a standard ESD control process.
- (2) The human body model is a 100-pF capacitor discharged through a 1.5-k $\Omega$  resistor into each pin.
- (3) The machine model is a 200-pF capacitor discharged directly into each pin.

### 6.3 Recommended Operating Conditions

over operating free-air temperature range (unless otherwise noted)

		MIN	NOM	MAX	UNIT
Temperature ( $T_{\min} \leq T_A \leq T_{\max}$ )	Industrial temperature	-40		85	°C
	Extended temperature	-40		125	
Reverse current	LM4051-1.2	0.06		12	mA
	LM4051-ADJ	0.06		12	
Output voltage	LM4051-ADJ	1.24		10	V

### 6.4 Thermal Information

THERMAL METRIC <sup>(1)</sup>		LM4051-ADJ, LM4051-1.2 V	UNIT
		DBZ	
		3 PINS	
$R_{\theta JA}$	Junction-to-ambient thermal resistance	214.7	°C/W
$R_{\theta JC(top)}$	Junction-to-case (top) thermal resistance	76.4	°C/W
$R_{\theta JB}$	Junction-to-board thermal resistance	41.3	°C/W
$\Psi_{JT}$	Junction-to-top characterization parameter	2.0	°C/W
$\Psi_{JB}$	Junction-to-board characterization parameter	40.9	°C/W

(1) For more information about traditional and new thermal metrics, see the [Semiconductor and IC Package Thermal Metrics](#) application report.

### 6.5 LM4051-1.2 Electrical Characteristics

over operating free-air temperature range (unless otherwise noted)

PARAMETER		TEST CONDITIONS		MIN	TYP	MAX	UNIT
$V_R$	Reverse Breakdown Voltage	$I_R = 100 \mu A$		1.225			V
	Reverse Breakdown Voltage Tolerance <sup>(1)</sup>	$I_R = 100 \mu A$	LM4051AIM3 <sup>(2)</sup>			$\pm 1.2$	mV
			LM4051BIM3 LM4051BEM3 <sup>(2)</sup>			$\pm 2.4$	
			LM4051CIM3 <sup>(2)</sup>			$\pm 6$	
		Industrial Temp. Range $T_A = T_J = T_{\min}$ to $T_{\max}$	LM4051AIM3 <sup>(2)</sup>			$\pm 5.2^{(1)}$	
			LM4051BIM3 <sup>(2)</sup>			$\pm 6.4^{(1)}$	
			LM4051CIM3 <sup>(2)</sup>			$\pm 10.1^{(1)}$	
Extended Temp. Range $T_A = T_J = T_{\min}$ to $T_{\max}$	LM4051BEM3 <sup>(2)</sup>			$\pm 8.6^{(1)}$			
$I_{RMIN}$	Minimum Operating Current	$T_J = 25^\circ C$		39		μA	
		Industrial Temp. Range $T_A = T_J = T_{\min}$ to $T_{\max}$		65			
		Extended Temp. Range $T_A = T_J = T_{\min}$ to $T_{\max}$		70			

(1) This overtemperature limit for Reverse Breakdown Voltage Tolerance is defined as the room temperature Reverse Breakdown Voltage Tolerance  $\pm [(\Delta VR/\Delta T)(\max \Delta T)(VR)]$ . Where,  $\Delta VR/\Delta T$  is the VR temperature coefficient,  $\max \Delta T$  is the maximum difference in temperature from the reference point of 25°C to TMAX or TMIN, and VR is the reverse breakdown voltage. The total overtemperature tolerance for the different grades in the industrial temperature range where  $\max \Delta T = 65^\circ C$  is shown below:

- (a) A-grade:  $\pm 0.425\% = \pm 0.1\% \pm 50 \text{ ppm}/^\circ C \times 65^\circ C$
- (b) B-grade:  $\pm 0.525\% = \pm 0.2\% \pm 50 \text{ ppm}/^\circ C \times 65^\circ C$
- (c) C-grade:  $\pm 0.825\% = \pm 0.5\% \pm 50 \text{ ppm}/^\circ C \times 65^\circ C$

Therefore, as an example, the A-grade LM4051-1.2 has an over-temperature Reverse Breakdown Voltage tolerance of  $\pm 1.2V \times 0.425\% = \pm 5.2 \text{ mV}$ .

(2) Limits are 100% production tested at 25°C. Limits over temperature are guaranteed through correlation using Statistical Quality Control (SQC) methods. The limits are used to calculate National's AOQL.

## LM4051-1.2 Electrical Characteristics (continued)

over operating free-air temperature range (unless otherwise noted)

PARAMETER		TEST CONDITIONS		MIN	TYP	MAX	UNIT
$\Delta V_R/\Delta T$	Average Reverse Breakdown Voltage Temperature Coefficient <sup>(1)</sup>	$I_R = 10 \text{ mA}$			$\pm 20$		ppm/°C
		$I_R = 1 \text{ mA}$			$\pm 15$		
		$I_R = 100 \mu\text{A}$	$T_J = 25^\circ\text{C}$		$\pm 15$		
		$\Delta T = -40^\circ\text{C to } 125^\circ\text{C}$				$\pm 50^{(1)}$	
$\Delta V_R/\Delta I_R$	Reverse Breakdown Voltage Change with Operating Current Change	$I_{R\text{MIN}} \leq I_R \leq 1 \text{ mA}$	$T_J = 25^\circ\text{C}$		0.3		mV
			Industrial Temp. Range $T_A = T_J = T_{\text{MIN}} \text{ to } T_{\text{MAX}}$			1.1 <sup>(1)</sup>	
			Extended Temp. Range $T_A = T_J = T_{\text{MIN}} \text{ to } T_{\text{MAX}}$			1.5 <sup>(1)</sup>	
		$1 \text{ mA} \leq I_R \leq 12 \text{ mA}$	$T_J = 25^\circ\text{C}$		1.8		
			Industrial Temp. Range $T_A = T_J = T_{\text{MIN}} \text{ to } T_{\text{MAX}}$			6 <sup>(1)</sup>	
			Extended Temp. Range $T_A = T_J = T_{\text{MIN}} \text{ to } T_{\text{MAX}}$			8 <sup>(1)</sup>	
$Z_R$	Reverse Dynamic Impedance	$I_R = 1 \text{ mA}, f = 120 \text{ Hz}$			0.5		$\Omega$
$e_N$	Wideband Noise	$I_R = 100 \mu\text{A}$ $10 \text{ Hz} \leq f \leq 10 \text{ kHz}$			20		$\mu\text{V}_{\text{rms}}$
$\Delta V_R$	Reverse Breakdown Voltage Long Term Stability <sup>(3)</sup>	$t = 1000 \text{ hrs}, T = 25^\circ\text{C} \pm 0.1^\circ\text{C}, I_R = 100 \mu\text{A}$			120		ppm
$V_{\text{HYST}}$	Thermal Hysteresis <sup>(4)</sup>	$\Delta T = -40^\circ\text{C to } 125^\circ\text{C}$			0.36		mV/V

(3) Long-term stability is  $V_R$  at  $25^\circ\text{C}$  measured during 1000 hrs.

(4) Thermal hysteresis is defined as the difference in voltage measured at  $+25^\circ\text{C}$  after cycling to temperature  $-40^\circ\text{C}$  and the  $25^\circ\text{C}$  measurement after cycling to temperature  $+125^\circ\text{C}$ .

## 6.6 LM4051-ADJ Electrical Characteristics

over operating free-air temperature range (unless otherwise noted)

PARAMETER		TEST CONDITIONS		MIN	TYP	MAX	UNIT
$V_{\text{REF}}$	Reference Voltage	$I_R = 100 \mu\text{A}, V_{\text{OUT}} = 5 \text{ V}$			1.212		V
	Reference Voltage Tolerance <sup>(1)(2)</sup>	$I_R = 100 \mu\text{A}, V_{\text{OUT}} = 5 \text{ V}$	LM4051AIM3 <sup>(3)</sup>			$\pm 1.2$	
			LM4051BIM3 <sup>(3)</sup>			$\pm 2.4$	
			LM4051CIM3 <sup>(3)</sup>			$\pm 6$	
		Industrial Temp. Range $T_A = T_J = T_{\text{MIN}} \text{ to } T_{\text{MAX}}$	LM4051AIM3 <sup>(3)</sup>			$\pm 5.2$	
			LM4051BIM3 <sup>(3)</sup>			$\pm 6.4$	
			LM4051CIM3 <sup>(3)</sup>			$\pm 10.1$	

(1) This overtemperature limit for Reverse Breakdown Voltage Tolerance is defined as the room temperature Reverse Breakdown Voltage Tolerance  $\pm [(\Delta V_R/\Delta T)(\text{max}\Delta T)(V_R)]$ . Where,  $\Delta V_R/\Delta T$  is the  $V_R$  temperature coefficient,  $\text{max}\Delta T$  is the maximum difference in temperature from the reference point of  $25^\circ\text{C}$  to  $T_{\text{MAX}}$  or  $T_{\text{MIN}}$ , and  $V_R$  is the reverse breakdown voltage. The total overtemperature tolerance for the different grades in the industrial temperature range where  $\text{max}\Delta T = 65^\circ\text{C}$  is shown below:

(a) A-grade:  $\pm 0.425\% = \pm 0.1\% \pm 50 \text{ ppm}/^\circ\text{C} \times 65^\circ\text{C}$ 

(b) B-grade:  $\pm 0.525\% = \pm 0.2\% \pm 50 \text{ ppm}/^\circ\text{C} \times 65^\circ\text{C}$ 

(c) C-grade:  $\pm 0.825\% = \pm 0.5\% \pm 50 \text{ ppm}/^\circ\text{C} \times 65^\circ\text{C}$ 

Therefore, as an example, the A-grade LM4051-1.2 has an overtemperature Reverse Breakdown Voltage tolerance of  $\pm 1.2 \text{ V} \times 0.425\% = \pm 5.2 \text{ mV}$ .

(2) Reference voltage and temperature coefficient will change with output voltage. See [Typical Characteristics](#) curves.

(3) Limits are 100% production tested at  $25^\circ\text{C}$ . Limits over temperature are ensured through correlation using Statistical Quality Control (SQC) methods. The limits are used to calculate National's AOQL.

**LM4051-ADJ Electrical Characteristics (continued)**

over operating free-air temperature range (unless otherwise noted)

PARAMETER		TEST CONDITIONS		MIN	TYP	MAX	UNIT	
$I_{RMIN}$	Minimum Operating Current	LM4051AIM3 <sup>(4)</sup>			36		$\mu\text{A}$	
		LM4051BIM3 <sup>(4)</sup>			36			
		LM4051CIM3 <sup>(4)</sup>			36			
		Industrial Temp. Range $T_A = T_J = T_{MIN}$ to $T_{MAX}$	LM4051AIM3 <sup>(3)</sup>		60			
			LM4051BIM3 <sup>(3)</sup>		60			
		LM4051CIM3 <sup>(3)</sup>		65				
$\Delta V_{REF}/\Delta I_R$	Reference Voltage Change with Operating Current Change	$I_{RMIN} \leq I_R \leq 1 \text{ mA}$ $V_{OUT} \geq 1.6 \text{ V}^{(5)}$	$T_J = 25^\circ\text{C}$		0.3		$\text{mV}$	
			Industrial Temp. Range $T_A = T_J = T_{MIN}$ to $T_{MAX}$			1.1 <sup>(1)</sup>		
		$1 \text{ mA} \leq I_R \leq 12 \text{ mA}$ $V_{OUT} \geq 1.6 \text{ V}^{(5)}$	$T_J = 25^\circ\text{C}$		0.6			
			Industrial Temp. Range $T_A = T_J = T_{MIN}$ to $T_{MAX}$			6 <sup>(1)</sup>		
$\Delta V_{REF}/\Delta V_O$	Reference Voltage Change with Output Voltage Change	$I_R = 0.1 \text{ mA}$	$T_J = 25^\circ\text{C}$		-1.69		$\text{mV}$	
			Industrial Temp. Range $T_A = T_J = T_{MIN}$ to $T_{MAX}$			-2.8 <sup>(1)</sup>		
$I_{FB}$	Feedback Current				70	130	$\text{nA}$	
$\Delta V_{REF}/\Delta T$	Average Reference Voltage Temperature Coefficient (Note 8)	$V_{OUT} = 2.5 \text{ V}$ $\Delta T = -40^\circ\text{C}$ to $+125^\circ\text{C}$	$I_R = 10 \text{ mA}$	$T_J = 25^\circ\text{C}$		20	$\text{ppm}/^\circ\text{C}$	
				Industrial Temp. Range $T_A = T_J = T_{MIN}$ to $T_{MAX}$				$\pm 50^{(1)}$
			$I_R = 1 \text{ mA}$	$T_J = 25^\circ\text{C}$		15		
				Industrial Temp. Range $T_A = T_J = T_{MIN}$ to $T_{MAX}$				$\pm 50^{(1)}$
$I_R = 100 \mu\text{A}$	$T_J = 25^\circ\text{C}$		15					
	Industrial Temp. Range $T_A = T_J = T_{MIN}$ to $T_{MAX}$			$\pm 50^{(1)}$				
$Z_{OUT}$	Dynamic Output Impedance	$I_R = 1 \text{ mA}$ , $f = 120 \text{ Hz}$ , $I_{AC} = 0.1 I_R$	$V_{OUT} = V_{REF}$		0.3		$\Omega$	
			$V_{OUT} = 10 \text{ V}$		2			
$e_N$	Wideband Noise	$I_R = 100 \mu\text{A}$ , $V_{OUT} = V_{REF}$ , $10 \text{ Hz} \leq f \leq 10 \text{ kHz}$			20		$\mu\text{Vrms}$	
$\Delta V_{REF}$	Reference Voltage Long Term Stability <sup>(6)</sup>	$t = 1000 \text{ hrs}$ , $I_R = 100 \mu\text{A}$ , $T = 25^\circ\text{C} \pm 0.1^\circ\text{C}$			120		$\text{ppm}$	
$V_{HYST}$	Thermal Hysteresis <sup>(7)</sup>	$\Delta T = -40^\circ\text{C}$ to $+125^\circ\text{C}$			0.3		$\text{mV/V}$	

- (4) Limits are 100% production tested at 25 °C. Limits over temperature are guaranteed through correlation using Statistical Quality Control (SQC) methods. The limits are used to calculate National's AOQL.
- (5) When  $V_{OUT} \leq 1.6 \text{ V}$ , the LM4051-ADJ in the SOT-23 package must operate at reduced  $I_R$ . This is caused by the series resistance of the die attach between the die (-) output and the package (-) output pin. See the Output Saturation curve in the [Typical Characteristics](#) section.
- (6) Long-term stability is  $V_R$  at 25 °C measured during 1000 hrs.
- (7) Thermal hysteresis is defined as the difference in voltage measured at +25 °C after cycling to temperature -40 °C and the 25 °C measurement after cycling to temperature +125 °C.

### 6.7 Typical Characteristics

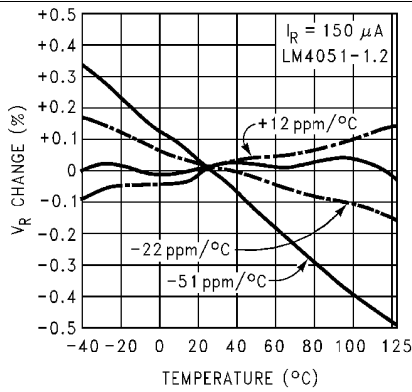

Figure 1. Temperature Drift for Different Average Temperature Coefficient

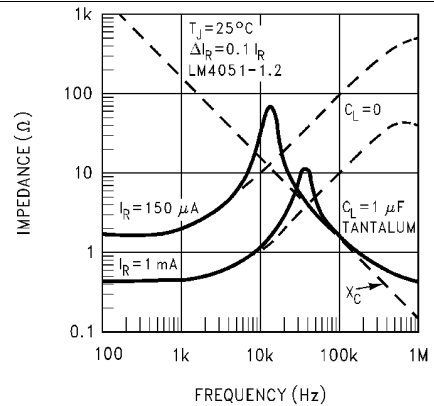

Figure 2. Output Impedance vs Frequency

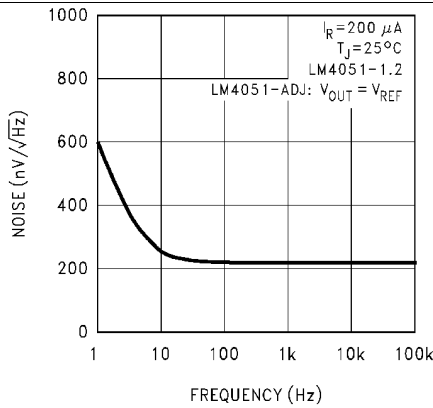

Figure 3. Noise Voltage

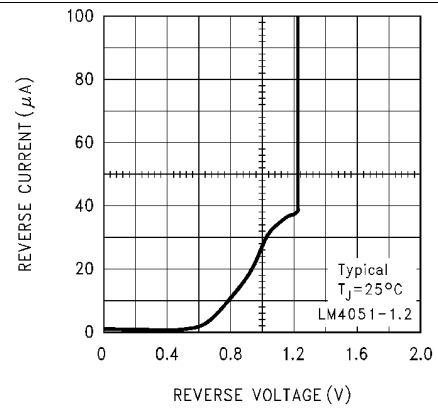

Figure 4. Reverse Characteristics and Minimum Operating Current

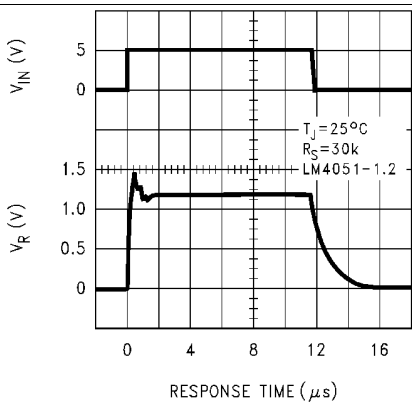

Figure 5. Start-Up Characteristics

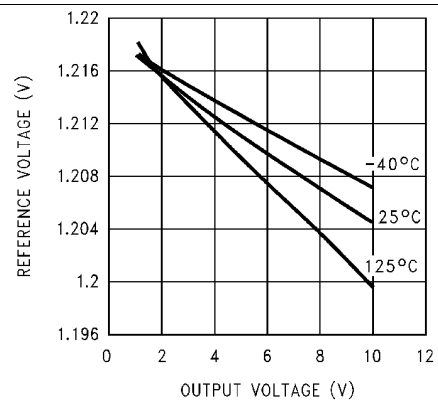

Figure 6. Reference Voltage vs Output Voltage and Temperature

Typical Characteristics (continued)

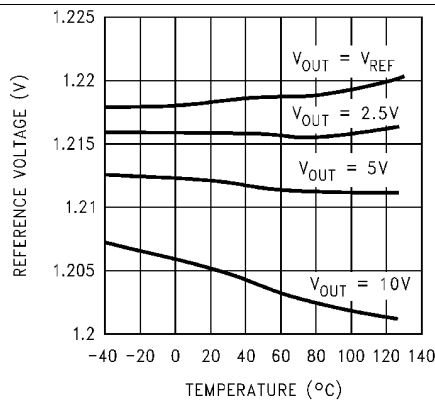

Figure 7. Reference Voltage vs Temperature and Output Voltage

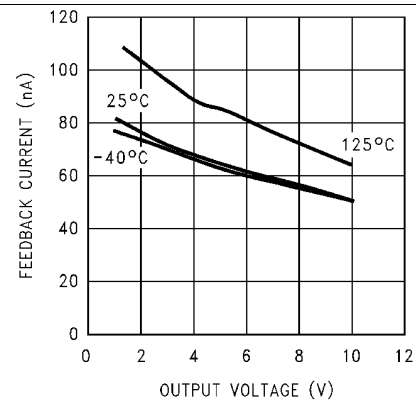

Figure 8. Feedback Current vs Output Voltage and Temperature

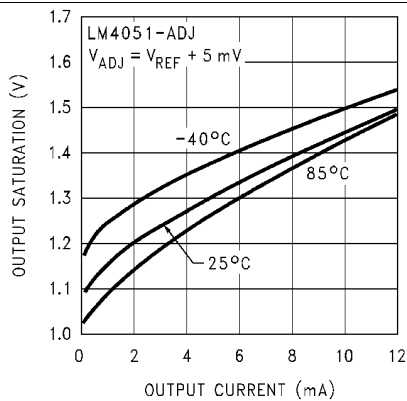

Figure 9. Output Saturation (SOT-23 Only)

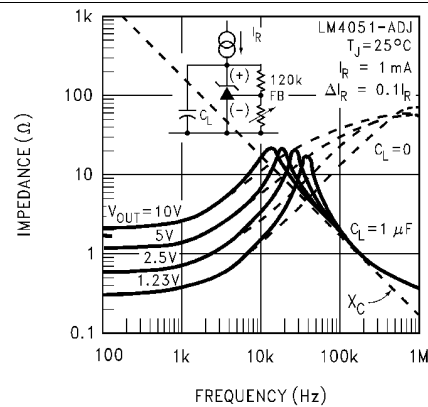

Figure 10. Output Impedance vs Frequency

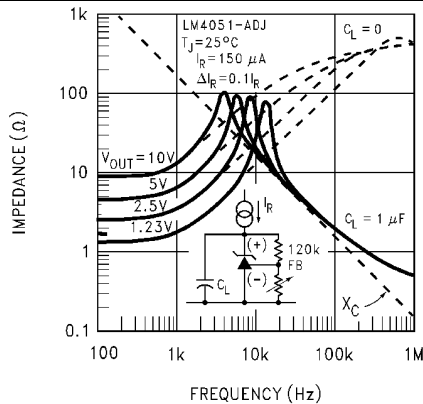

Figure 11. Output Impedance vs Frequency

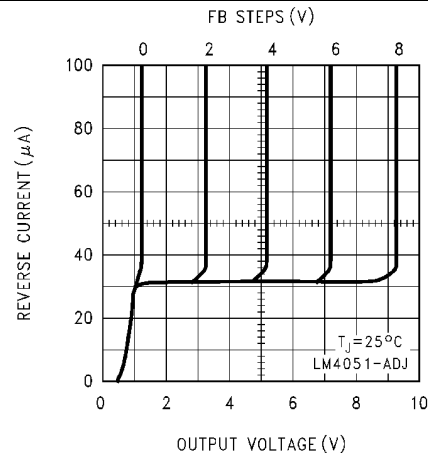
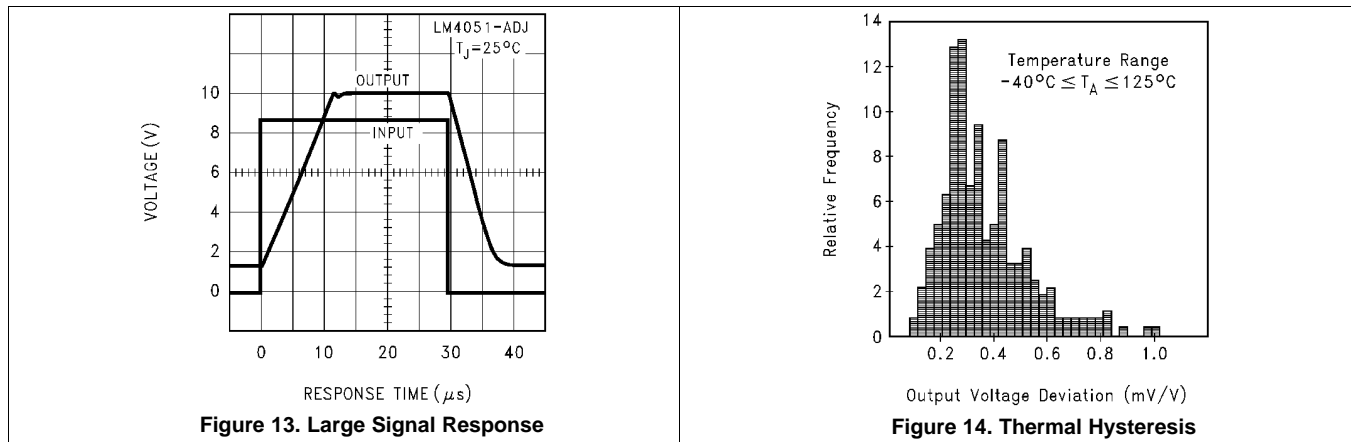

Figure 12. Reverse Characteristics



Typical Characteristics (continued)



7 Parameter Measurement Information

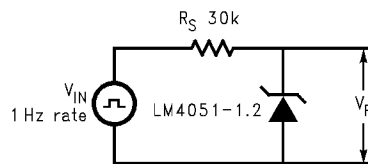

Figure 15. Test Circuit for Start-Up Characteristics

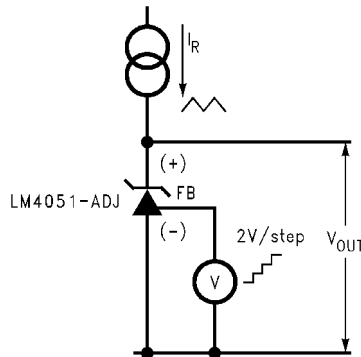

Figure 16. Test Circuit for Reverse Characteristics

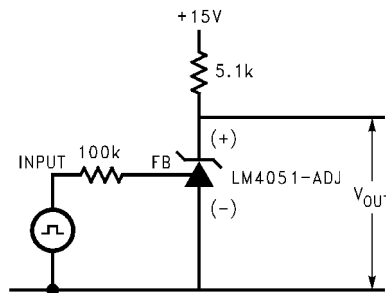

Figure 17. Test Circuit for Large Signal Response

## 8 Detailed Description

### 8.1 Overview

The LM4051-N is a precision voltage reference available in SOT-23 surface mount package. The LM4051-N is available in a 1.225 V fixed-option as well as an adjustable voltage option. The LM4051-N comes in three different tolerance grades (A, B, and C). The best grade devices (A) have an initial accuracy of 0.1%, while the B-grade have 0.2% and the C-grade 0.5%, all with a temperature coefficient of 50 ppm/°C guaranteed from -40°C to 125°C.

### 8.2 Functional Block Diagram

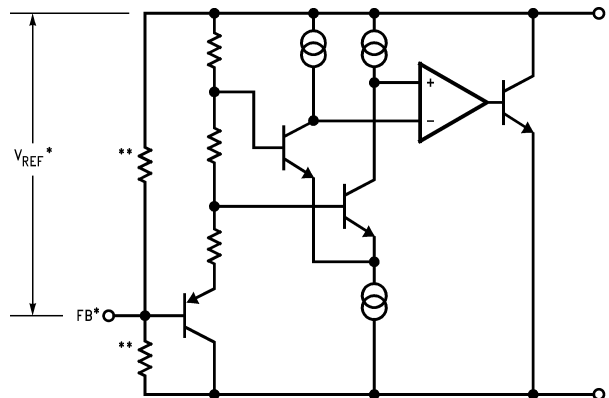

\*LM4051-ADJ only

\*\*LM4051-1.2 only

### 8.3 Feature Description

The LM4051-N device is effectively a precision Zener diode. The part requires a small quiescent current for regulation, and regulates the output voltage by shunting more or less current to ground, depending on input voltage and load. The only external component requirement is a resistor between the cathode and the input voltage to set the input current. An external capacitor can be used on the input or output, but is not required.

For the adjustable version, feedback is applied from the Cathode and Reference pins, the LM4051-N behaves as a Zener diode, regulating to a constant voltage dependent on current being supplied into the cathode. This is due to the internal amplifier and reference entering the proper operating regions. The same amount of current needed in the above feedback situation must be applied to this device in open loop, servo or error amplifying implementations in order for it to be in the proper linear region giving the LM4051-N enough gain.

### 8.4 Device Functional Modes

#### 8.4.1 LM4051-N - 1.2 V

The LM4051-N - 1.2V device is a fixed output voltage part, where the feedback is internal. Therefore, the part can only operate in a closed loop mode and the output voltage cannot be adjusted. The output voltage will remain in regulation as long as  $IR$  is between  $IR_{MIN}$ . Proper selection of the external resistor for input voltage range and load current range will ensure these conditions are met.

#### 8.4.2 LM4051-N - ADJ

The majority of applications involving LM4051-N uses closed loop operation to regulate a fixed voltage or current. The feedback enables this device to behave as an error amplifier, computing a portion of the output voltage and adjusting it to maintain the desired regulation. This is done by relating the output voltage back to the reference pin in a manner to make it equal to the internal reference voltage, which can be accomplished via resistive or direct feedback.

## 9 Application and Implementation

### NOTE

Information in the following applications sections is not part of the TI component specification, and TI does not warrant its accuracy or completeness. TI's customers are responsible for determining suitability of components for their purposes. Customers should validate and test their design implementation to confirm system functionality.

### 9.1 Application Information

The LM4051-N is a precision micro-power curvature-corrected bandgap shunt voltage reference. For space critical applications, the LM4051-N is available in the sub-miniature SOT-23 surface-mount package. The LM4051-N has been designed for stable operation without the need of an external capacitor connected between the “+” pin and the “-” pin. If, however, a bypass capacitor is used, the LM4051-N remains stable. Design effort is further reduced with the choice of either a fixed 1.2-V or an adjustable reverse breakdown voltage. The minimum operating current is 60  $\mu$ A for the LM4051-1.2 and the LM4051-ADJ. Both versions have a maximum operating current of 12 mA.

LM4051-N's using the SOT-23 package have pin 3 connected as the (–) output through the package's die attach interface. Therefore, the LM4051-1.2's pin 3 must be left floating or connected to pin 2 and the LM4051-ADJ's pin 3 is the (–) output.

The typical thermal hysteresis specification is defined as the change in +25  $^{\circ}$ C voltage measured after thermal cycling. The device is thermal cycled to temperature –40  $^{\circ}$ C and then measured at 25  $^{\circ}$ C. Next the device is thermal cycled to temperature +125  $^{\circ}$ C and again measured at 25  $^{\circ}$ C. The resulting  $V_{OUT}$  delta shift between the 25  $^{\circ}$ C measurements is thermal hysteresis. Thermal hysteresis is common in precision references and is induced by thermal-mechanical package stress. Changes in environmental storage temperature, operating temperature and board mounting temperature are all factors that can contribute to thermal hysteresis.

In a conventional shunt regulator application ([Figure 18](#)), an external series resistor ( $R_S$ ) is connected between the supply voltage and the LM4051-N.  $R_S$  determines the current that flows through the load ( $I_L$ ) and the LM4051-N ( $I_Q$ ). Since load current and supply voltage may vary,  $R_S$  should be small enough to supply at least the minimum acceptable  $I_Q$  to the LM4051-N even when the supply voltage is at its minimum and the load current is at its maximum value. When the supply voltage is at its maximum and  $I_L$  is at its minimum,  $R_S$  should be large enough so that the current flowing through the LM4051-N is less than 12 mA.

$R_S$  should be selected based on the supply voltage, ( $V_S$ ), the desired load and operating current, ( $I_L$  and  $I_Q$ ), and the LM4051-N's reverse breakdown voltage,  $V_R$ .

$$R_S = \frac{V_S - V_R}{I_L + I_Q} \quad (1)$$

The LM4051-ADJ's output voltage can be adjusted to any value in the range of 1.24 V through 10 V. It is a function of the internal reference voltage ( $V_{REF}$ ) and the ratio of the external feedback resistors as shown in [Figure 20](#). The output voltage is found using [Equation 2](#):

$$V_O = V_{REF} \left[ \left( \frac{R_2}{R_1} \right) + 1 \right]$$

where

- $V_O$  is the output voltage (2)

$$R_S = \frac{V_S - V_R}{I_L + I_Q + I_F} \quad (3)$$

The actual value of the internal  $V_{REF}$  is a function of  $V_O$ . The *corrected*  $V_{REF}$  is determined by [Equation 4](#):

$$V_{REF} = V_O \left( \Delta V_{REF} / \Delta V_O \right) + V_Y$$

where

- $V_Y = 1.22$  V (4)

## Application Information (continued)

$\Delta V_{REF}/\Delta V_O$  is found in the [LM4051-ADJ Electrical Characteristics](#) and is typically  $-1.55$  mV/V. You can get a more accurate indication of the output voltage by replacing the value of  $V_{REF}$  in [Equation 2](#) with the value found using [Equation 4](#).

## 9.2 Typical Applications

### 9.2.1 Shunt Regulator

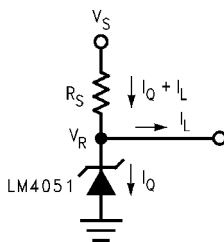

**Figure 18. Shunt Regulator**

#### 9.2.1.1 Design Requirements

$$V_{IN} > V_{OUT}$$

Select  $R_S$  such that:

$$I_{R_{MIN}} < I_R < I_{R_{MAX}} \text{ where } I_{R_{MAX}} = 12 \text{ mA}$$

See [LM4051-1.2 Electrical Characteristics](#) for minimum operating current for each voltage option and grade.

#### 9.2.1.2 Detailed Design Procedure

The resistor  $R_S$  must be selected such that current,  $I_R$ , will remain in the operational region of the part for the entire  $V_{IN}$  range and load current range. The two extremes to consider are  $V_{IN}$  at its maximum, and the load at its minimum, where  $R_S$  must be large enough to main  $I_R < I_{R_{MAX}}$ . For most designs,  $0.1 \text{ mA} \leq I_R \leq 1 \text{ mA}$  is a good starting point.

Use cross and cross to set  $R_S$  between  $R_{S\_MIN}$  and  $R_{S\_MAX}$ .

$$R_{S\_MIN} = \frac{V_{IN\_MAX} - V_{OUT}}{I_{LOAD\_MIN} + I_{R\_MAX}} \quad (5)$$

$$R_{S\_MAX} = \frac{V_{IN\_MIN} - V_{OUT}}{I_{LOAD\_MAX} + I_{R\_MIN}} \quad (6)$$

## Typical Applications (continued)

### 9.2.1.3 Application Curves

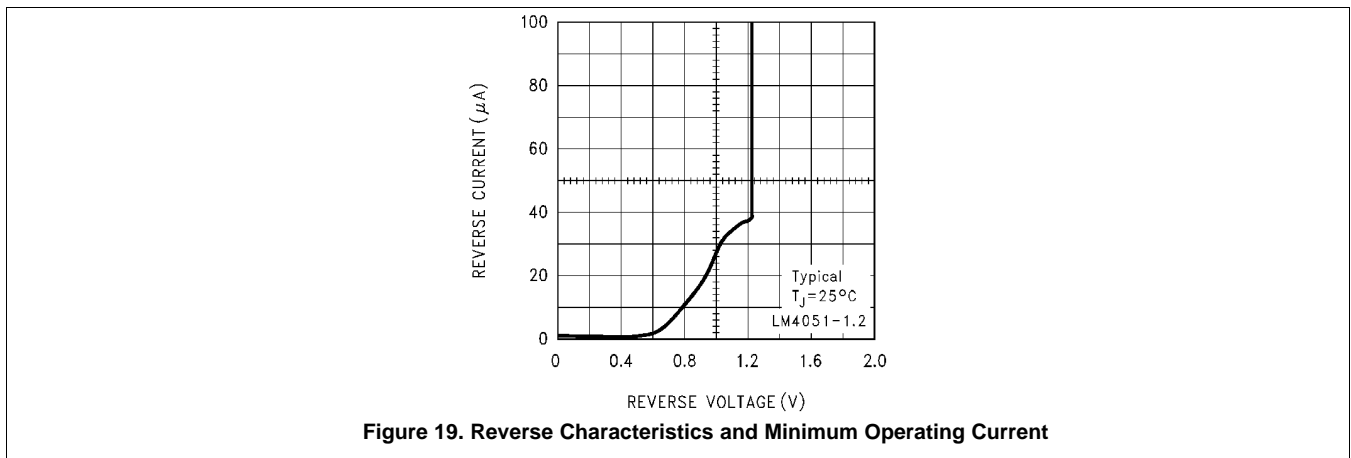

## 9.2.2 Adjustable Shunt Regulator

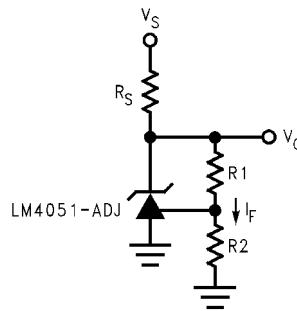

Figure 20. Adjustable Shunt Regulator

### 9.2.2.1 Design Requirements

$$V_{IN} > V_{OUT}$$

Select  $R_S$  such that:

$$I_{RMIN} < I_R < I_{RMAX} \text{ where } I_{RMAX} = 12 \text{ mA}$$

See [LM4051-ADJ Electrical Characteristics](#) for minimum operating current for each voltage option and grade.

### 9.2.2.2 Detailed Design Procedure

In order to program the cathode voltage to a regulated voltage a resistive bridge must be shunted between the cathode and anode pins with the mid point tied to the reference pin. This can be seen in [Figure 20](#), with R1 & R2 being the resistive bridge. The cathode/output voltage in the shunt regulator configuration can be approximated by the equation shown in [Equation 7](#). The cathode voltage can be more accurately determined by taking in to account the cathode current shown in [Equation 8](#).

$$V_o = \left(1 + \frac{R_1}{R_2}\right) \times V_{REF} \tag{7}$$

$$V_o = \left(1 + \frac{R_1}{R_2}\right) \times (V_{REF} - I_{REF} \times R_1) \tag{8}$$

### Typical Applications (continued)

In order for this equation to be valid, LM4051-ADJ must be fully biased so that it has enough open loop gain to mitigate any gain error. This can be done by meeting the  $I_{RMIN}$  denoted in [LM4051-ADJ Electrical Characteristics](#).

### 9.3 System Examples

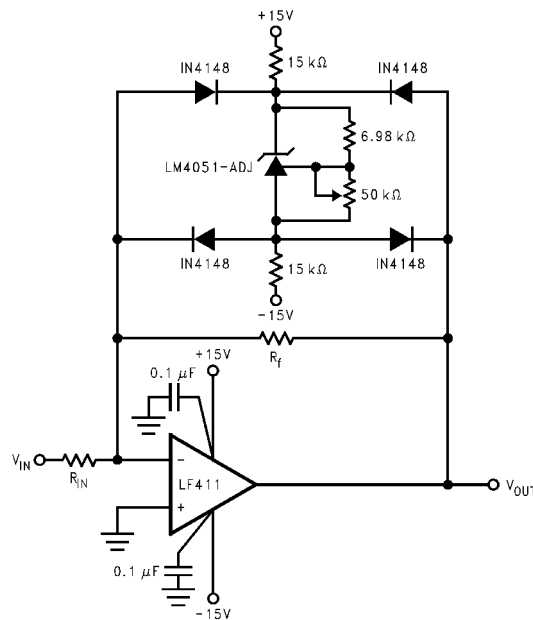

Figure 21. Bounded Amplifier Reduces Saturation-induced Delays and Can Prevent Succeeding Stage Damage. Nominal Clamping Voltage is  $\pm V_O$  (LM4051-N's Reverse Breakdown Voltage) +2 Diode  $V_F$ .

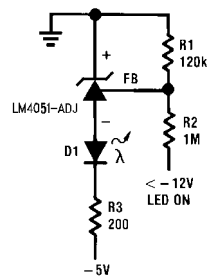

Figure 22. Voltage Level Detector

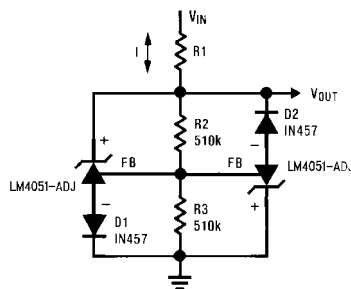

Figure 23. Voltage Level Detector

System Examples (continued)

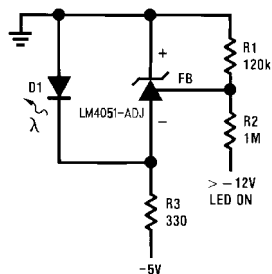

Figure 24. Fast Positive Clamp  $2.4V + V_{D1}$

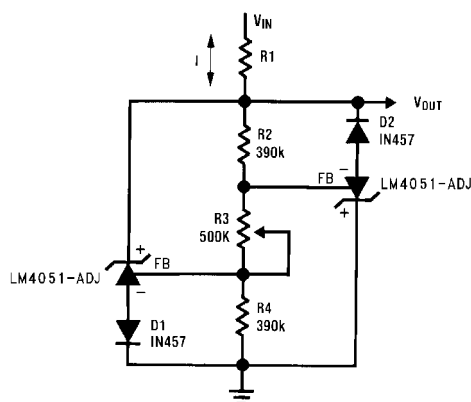

Figure 25. Bidirectional Clamp  $\pm 2.4V$

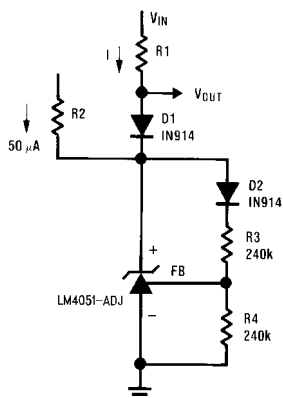

Figure 26. Bidirectional Adjustable Clamp  $\pm 18V$  to  $\pm 2.4V$

System Examples (continued)

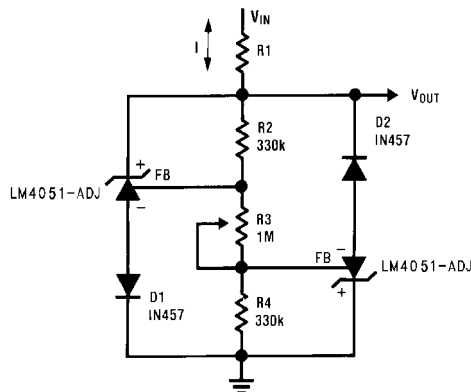

Figure 27. Bidirectional Adjustable Clamp  $\pm 2.4V$  to  $\pm 6V$

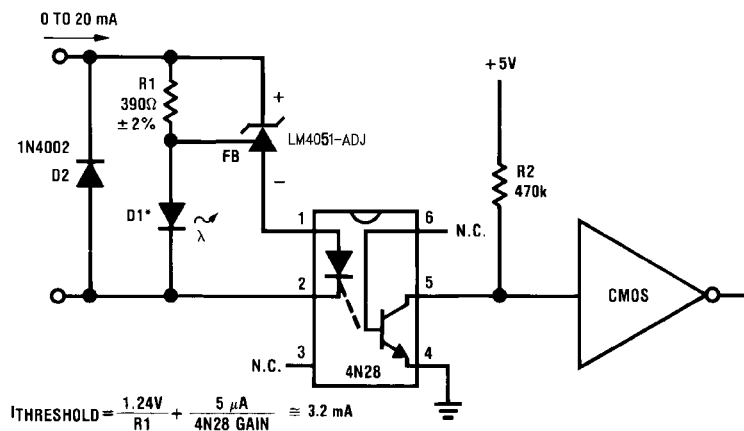
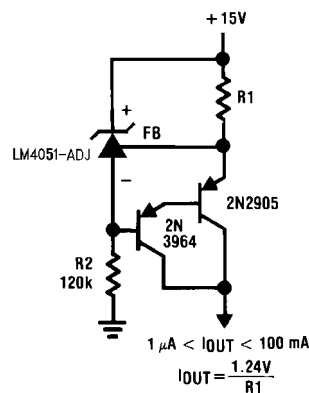

Figure 28. Simple Floating Current Detector



\*D1 can be any LED,  $V_F = 1.5V$  to  $2.2V$  at  $3\text{ mA}$ . D1 may act as an indicator. D1 will be on if  $I_{THRESHOLD}$  falls below the threshold current, except with  $I = 0$ .

Figure 29. Current Source



System Examples (continued)

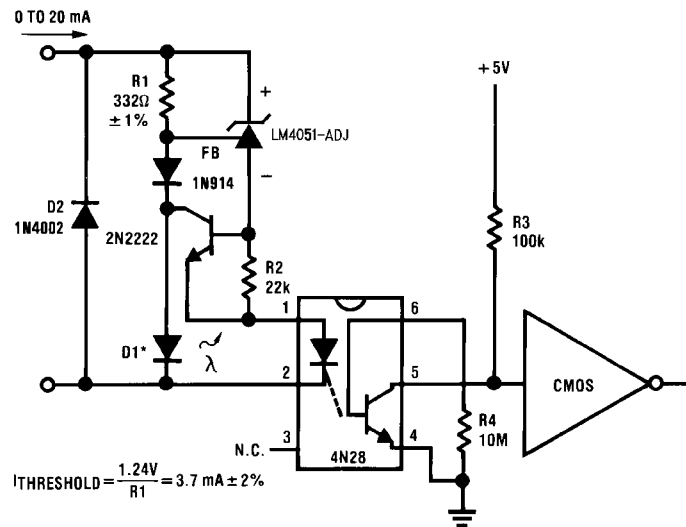

Figure 30. Precision Floating Current Detector

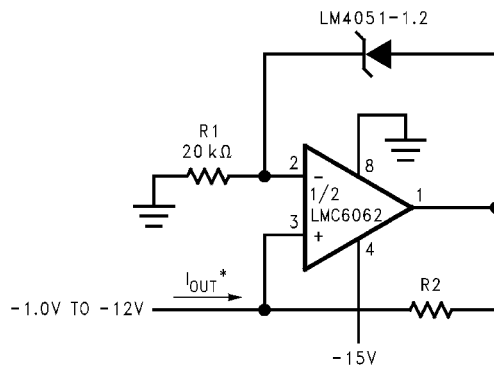

Figure 31. Precision 1 μA to 1 mA Current Source

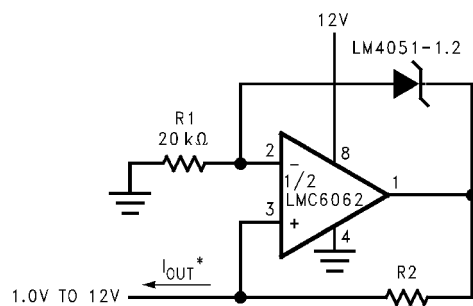

Figure 32. Precision 1 μA to 1 mA Current Source

## 10 Power Supply Recommendations

While a bypass capacitor is not required on the input voltage line, TI recommends reducing noise on the input which could affect the output. A 0.1- $\mu\text{F}$  ceramic capacitor or larger is recommended.

In order to not exceed the maximum cathode current, be sure that the supply current is limited. For applications shunting high currents, pay attention to the cathode and anode trace lengths, adjusting the width of the traces to have proper current density.

## 11 Layout

### 11.1 Layout Guidelines

Bypass capacitors should be placed as close to the device as possible. Current-carrying traces need to have widths appropriate for the amount of current they are carrying. Place  $R_S$  as close as possible to the cathode. Although not as critical, keep feedback resistor close to the device whenever possible.

### 11.2 Layout Example

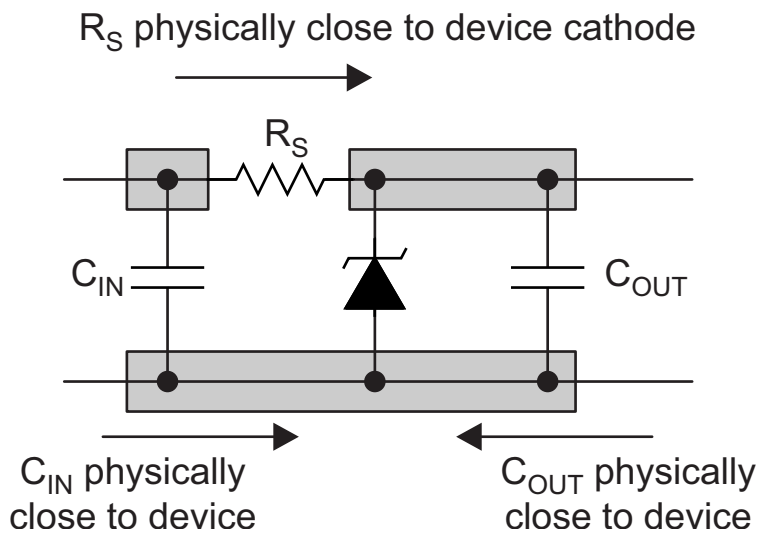

Figure 33. Layout Diagram

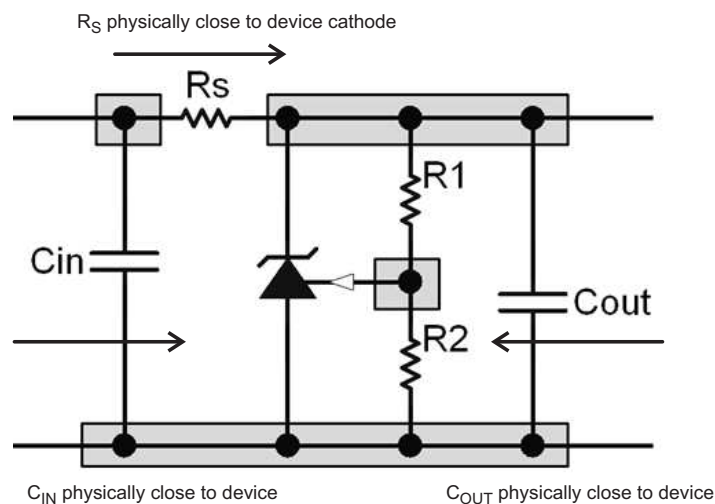

Figure 34. Feedback Resistors Layout Diagram

## 12 デバイスおよびドキュメントのサポート

### 12.1 ドキュメントの更新通知を受け取る方法

ドキュメントの更新についての通知を受け取るには、[ti.com](http://ti.com)のデバイス製品フォルダを開いてください。右上の隅にある「通知を受け取る」をクリックして登録すると、変更されたすべての製品情報に関するダイジェストを毎週受け取れます。変更の詳細については、修正されたドキュメントに含まれている改訂履歴をご覧ください。

### 12.2 コミュニティ・リソース

The following links connect to TI community resources. Linked contents are provided "AS IS" by the respective contributors. They do not constitute TI specifications and do not necessarily reflect TI's views; see TI's [Terms of Use](#).

**TI E2E™オンライン・コミュニティ** *TIのE2E (Engineer-to-Engineer) コミュニティ*。エンジニア間の共同作業を促進するために開設されたものです。e2e.ti.comでは、他のエンジニアに質問し、知識を共有し、アイデアを検討して、問題解決に役立てることができます。

**設計サポート** *TIの設計サポート* 役に立つE2Eフォーラムや、設計サポート・ツールをすばやく見つけることができます。技術サポート用の連絡先情報も参照できます。

### 12.3 商標

E2E is a trademark of Texas Instruments.  
All other trademarks are the property of their respective owners.

### 12.4 静電気放電に関する注意事項



すべての集積回路は、適切なESD保護方法を用いて、取扱いと保存を行うようにして下さい。

静電気放電はわずかな性能の低下から完全なデバイスの故障に至るまで、様々な損傷を与えます。高精度の集積回路は、損傷に対して敏感であり、極めてわずかなパラメータの変化により、デバイスに規定された仕様に適合しなくなる場合があります。

### 12.5 Glossary

**SLYZ022** — *TI Glossary*.

This glossary lists and explains terms, acronyms, and definitions.

## 13 メカニカル、パッケージ、および注文情報

以降のページには、メカニカル、パッケージ、および注文に関する情報が記載されています。この情報は、そのデバイスについて利用可能な最新のデータです。このデータは予告なく変更されることがあり、ドキュメントが改訂される場合もあります。本データシートのブラウザ版を使用されている場合は、画面左側の説明をご覧ください。

**表 1. SOT-23パッケージのマーキング情報**

部品マーキング	フィールドの定義		
RHA RIA	最初のフィールド: R = 基準電圧	2番目のフィールド: H = 1.225V電圧オプション I = 可変	3番目のフィールド: A-C = 初期予約の降伏電圧 または基準電圧の許容誤差 A = ±0.1%、B = ±0.2%、C = ±0.5%
RHB RIB			
RHC RIC			

## 重要なお知らせと免責事項

TI は、技術データと信頼性データ(データシートを含みます)、設計リソース(リファレンス・デザインを含みます)、アプリケーションや設計に関する各種アドバイス、Web ツール、安全性情報、その他のリソースを、欠陥が存在する可能性のある「現状のまま」提供しており、商品性および特定目的に対する適合性の黙示保証、第三者の知的財産権の非侵害保証を含むいかなる保証も、明示的または黙示的にかかわらず拒否します。

これらのリソースは、TI 製品を使用する設計の経験を積んだ開発者への提供を意図したものです。(1) お客様のアプリケーションに適した TI 製品の選定、(2) お客様のアプリケーションの設計、検証、試験、(3) お客様のアプリケーションが適用される各種規格や、その他のあらゆる安全性、セキュリティ、またはその他の要件を満たしていることを確実にする責任を、お客様のみが単独で負うものとします。上記の各種リソースは、予告なく変更される可能性があります。これらのリソースは、リソースで説明されている TI 製品を使用するアプリケーションの開発の目的でのみ、TI はその使用をお客様に許諾します。これらのリソースに関して、他の目的で複製することや掲載することは禁止されています。TI や第三者の知的財産権のライセンスが付与されている訳ではありません。お客様は、これらのリソースを自身で使用した結果発生するあらゆる申し立て、損害、費用、損失、責任について、TI およびその代理人を完全に補償するものとし、TI は一切の責任を拒否します。

TI の製品は、TI の販売条件 ([www.tij.co.jp/ja-jp/legal/termssofsale.html](http://www.tij.co.jp/ja-jp/legal/termssofsale.html))、または [ti.com](http://ti.com) やかかる TI 製品の関連資料などのいずれかを通じて提供する適用可能な条項の下で提供されています。TI がこれらのリソースを提供することは、適用される TI の保証または他の保証の放棄の拡大や変更を意味するものではありません。

Copyright © 2018, Texas Instruments Incorporated  
日本語版 日本テキサス・インスツルメンツ株式会社

## 重要なお知らせと免責事項

TI は、技術データと信頼性データ(データシートを含みます)、設計リソース(リファレンス・デザインを含みます)、アプリケーションや設計に関する各種アドバイス、Web ツール、安全性情報、その他のリソースを、欠陥が存在する可能性のある「現状のまま」提供しており、商品性および特定目的に対する適合性の黙示保証、第三者の知的財産権の非侵害保証を含むいかなる保証も、明示的または黙示的にかかわらず拒否します。

これらのリソースは、TI 製品を使用する設計の経験を積んだ開発者への提供を意図したものです。(1) お客様のアプリケーションに適した TI 製品の選定、(2) お客様のアプリケーションの設計、検証、試験、(3) お客様のアプリケーションが適用される各種規格や、その他のあらゆる安全性、セキュリティ、またはその他の要件を満たしていることを確実にする責任を、お客様のみが単独で負うものとします。上記の各種リソースは、予告なく変更される可能性があります。これらのリソースは、リソースで説明されている TI 製品を使用するアプリケーションの開発の目的でのみ、TI はその使用をお客様に許諾します。これらのリソースに関して、他の目的で複製することや掲載することは禁止されています。TI や第三者の知的財産権のライセンスが付与されている訳ではありません。お客様は、これらのリソースを自身で使用した結果発生するあらゆる申し立て、損害、費用、損失、責任について、TI およびその代理人を完全に補償するものとし、TI は一切の責任を拒否します。

TI の製品は、TI の販売条件 ([www.tij.co.jp/ja-jp/legal/termsofsale.html](http://www.tij.co.jp/ja-jp/legal/termsofsale.html))、または [ti.com](http://ti.com) やかかる TI 製品の関連資料などのいずれかを通じて提供する適用可能な条項の下で提供されています。TI がこれらのリソースを提供することは、適用される TI の保証または他の保証の放棄の拡大や変更を意味するものではありません。

Copyright © 2018, Texas Instruments Incorporated  
日本語版 日本テキサス・インスツルメンツ株式会社