

LM66100 入力極性保護機能搭載、5.5V、1.5A、79mΩ、低静止電流 (IQ) の理想的なダイオード

1 特長

- 広い動作電圧範囲：1.5V～5.5V
- VIN の逆電圧スタンドオフ：
絶対最大定格 -6V
- 最大連続電流 (I_{MAX}): 1.5A
- オン抵抗 (R_{ON})
 - 5V V_{IN} = 79mΩ (標準値)
 - 3.6V V_{IN} = 91mΩ (標準値)
 - 1.8V V_{IN} = 141mΩ (標準値)
- コンパレータのチップ・イネーブル (CE)
- チャネルのステータス表示 (ST)
- 低消費電流
 - 3.6V V_{IN} 時のシャットダウン電流 (I_{SD,VIN}): 120nA (標準値)
 - 3.6V V_{IN} 時の静止電流 (I_{Q, VIN}): 150nA (標準値)

2 アプリケーション

- スマート・メーター
- ビルディング・オートメーション
- GPS およびトラッキング
- プライマリおよびバックアップ・バッテリー

3 概要

LM66100 は、各種アプリケーションに適した単一入力、単一出力 (SISO) の集積化理想ダイオードです。このデバイスは、1.5V～5.5V の入力電圧範囲で動作でき、最大 1.5A の連続電流をサポートできる P チャネル MOSFET を内蔵しています。

チップ・イネーブルは、 \overline{CE} ピンの電圧を入力電圧と比較することで動作します。 \overline{CE} ピンの電圧が VIN より高い場合、デバイスはディセーブルで、MOSFET はオフです。 \overline{CE} ピンの電圧の方が低い場合、MOSFET はオンです。LM66100 には逆極性保護 (RPP) 機能もあり、バッテリーの逆接続など入力の誤配線からデバイスを保護します。

デュアル・ダイオードの OR 実装のように、2 つの LM66100 を OR 構成で使用することもできます。この構成では、極めて高い入力電圧を出力に伝達しながら、逆電流が入力電源に流れ込むのを阻止できます。これらのデバイスは内部電圧コンパレータで入力と出力の電圧を比較し、逆電流がブロックされるようにします。

LM66100 は標準の SC-70 パッケージで供給され、-40°C～125°C の接合部温度範囲で仕様が規定されています。

製品情報⁽¹⁾

型番	パッケージ	本体サイズ (公称)
LM66100	SC-70 (6)	2.1mmx2.0mm

(1) 提供されているすべてのパッケージについては、巻末の注文情報を参照してください。

代表的なアプリケーション

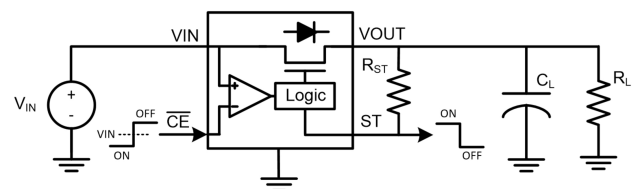

目次

1	特長	1	8.3	Feature Description	9
2	アプリケーション	1	8.4	Device Functional Modes	10
3	概要	1	9	Application and Implementation	10
4	改訂履歴	2	9.1	Application Information	10
5	Pin Configuration and Functions	3	9.2	Typical Applications	10
6	Specifications	4	10	Power Supply Recommendations	13
6.1	Absolute Maximum Ratings	4	11	Layout	14
6.2	ESD Ratings	4	11.1	Layout Guidelines	14
6.3	Recommended Operating Conditions	4	11.2	Layout Example	14
6.4	Thermal Information	4	12	デバイスおよびドキュメントのサポート	15
6.5	Electrical Characteristics	5	12.1	ドキュメントの更新通知を受け取る方法	15
6.6	Switching Characteristics	5	12.2	コミュニティ・リソース	15
6.7	Typical Characteristics	6	12.3	商標	15
7	Parameter Measurement Information	7	12.4	静電気放電に関する注意事項	15
8	Detailed Description	8	12.5	Glossary	15
8.1	Overview	8	13	メカニカル、パッケージ、および注文情報	15
8.2	Functional Block Diagram	8			

4 改訂履歴

2019年3月発行のものから更新

Page

• 事前情報から量産データに変更	1
------------------------	----------

5 Pin Configuration and Functions

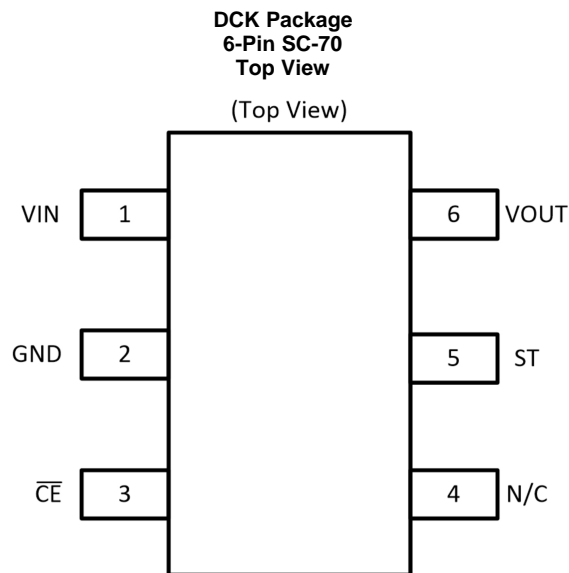

Pin Functions

PIN		I/O	DESCRIPTION
NO.	NAME		
1	VIN	I	Device input
2	GND	-	Device ground
3	\overline{CE}	I	Active-low chip enable. Can be connected to VOUT for reverse current protection. Do not leave floating.
4	N/C	-	Not internally connected, can be tied to GND or left floating.
5	ST	O	Active-low open-drain output, pulled low when the chip is disabled. Hi-Z when the chip is enabled. Connect to GND if not required.
6	VOUT	O	Device output

6 Specifications

6.1 Absolute Maximum Ratings

over operating free-air temperature range (unless otherwise noted) ⁽¹⁾

		MIN	MAX	UNIT
V _{IN}	Maximum Input Voltage Range	-6	6	V
V _{OUT}	Maximum Output Voltage Range	-0.3	6	V
V _{CE}	Maximum $\overline{\text{CE}}$ Pin Voltage	-0.3	6	V
V _{ST}	Maximum ST Pin Voltage	-0.3	6	V
I _{SW, MAX}	Maximum Continuous Switch Current		1.5	A
I _{SW, PLS}	Maximum Pulsed Switch Current (≤120 ms, 2% Duty Cycle)		2.5	A
I _{D, PLS}	Maximum Pulsed Body Diode Current (≤0.1 ms, 0.2% Duty Cycle)		2.5	A
I _{CE}	Maximum $\overline{\text{CE}}$ Pin Current	-1		mA
I _{ST}	Maximum ST Pin Current	-1		mA
T _J	Junction temperature	-40	125	°C
T _{STG}	Storage temperature	-65	150	°C
T _{LEAD}	Maximum Lead Temperature (10 s soldering time)		300	°C

(1) Stresses beyond those listed under *Absolute Maximum Rating* may cause permanent damage to the device. These are stress ratings only, which do not imply functional operation of the device at these or any other conditions beyond those indicated under *Recommended Operating Condition*. Exposure to absolute-maximum-rated conditions for extended periods may affect device reliability.

6.2 ESD Ratings

			VALUE	UNIT
V _(ESD)	Electrostatic discharge	Human body model (HBM), per ANSI/ESDA/JEDEC JS-001, allpins ⁽¹⁾	±2000	V
		Charged device model (CDM), per JEDEC specification JESD22-C101, all pins ⁽²⁾	±500	

(1) JEDEC document JEP155 states that 500-V HBM allows safe manufacturing with a standard ESD control process.

(2) JEDEC document JEP157 states that 250-V CDM allows safe manufacturing with a standard ESD control process. Manufacturing with less is possible with the necessary precautions. Pins listed may actually have higher performance.

6.3 Recommended Operating Conditions

over operating free-air temperature range (unless otherwise noted)

		MIN	TYP	MAX	UNIT
V _{IN}	Input Voltage Range	1.5		5.5	V
V _{OUT}	Output Voltage Range	1		5.5	V
V _{CE}	$\overline{\text{CE}}$ Pin Voltage Range	0		5.5	V
V _{ST}	ST Pin Voltage Range	0		5.5	V

6.4 Thermal Information

THERMAL METRIC ⁽¹⁾		LM66100	UNIT
		DCK (SC-70)	
		6 PINS	
R _{θJA}	Junction-to-ambient thermal resistance	192	°C/W
R _{θJC(top)}	Junction-to-case (top) thermal resistance	124	°C/W
R _{θJB}	Junction-to-board thermal resistance	52	°C/W
Ψ _{JT}	Junction-to-top characterization parameter	34	°C/W
Ψ _{JB}	Junction-to-board characterization parameter	52	°C/W

(1) For more information about traditional and new thermal metrics, see the [Semiconductor and IC Package Thermal Metrics](#) application report.

6.5 Electrical Characteristics

Typical values are at 25°C with an input voltage of 3.6V (unless otherwise noted)

PARAMETER		TEST CONDITIONS		MIN	TYP	MAX	UNIT	
Input Supply (VIN)								
$I_{SD,VIN}$	VIN Shutdown Current	VOUT = VIN VCE > VIN + 80mV IOUT = 0 A (VOUT = open)	25°C	0.12	0.3		μA	
			-40°C to 105°C			0.3	μA	
$I_{Q,VIN}$	VIN Quiescent Current	VOUT = VIN VCE < VIN - 250mV IOUT = 0 A (VOUT = open)	25°C	0.15	0.3		μA	
			-40°C to 105°C			0.3	μA	
$I_{OUT, OFF}$	OUT to IN Leakage Current (Current out of VIN)	VOUT - VIN ≤ 5.5 V VCE > VIN + 80mV	25°C	0.2	0.5		μA	
			-40°C to 85°C			2.7	μA	
			-40°C to 105°C			8	μA	
		VOUT - VIN ≤ 4.5 V VCE > VIN + 80mV	-40°C to 85°C			1.7	μA	
			-40°C to 105°C			5.1	μA	
			-40°C to 85°C			0.7	μA	
-40°C to 105°C			2.1	μA				
ON-Resistance (RON)								
R_{ON}	ON-State Resistance	IOUT = -200 mA	VIN = 5 V	25°C	79	95	mΩ	
				-40°C to 85°C				110
				-40°C to 125°C				120
R_{ON}	ON-State Resistance	IOUT = -200 mA	VIN = 3.6 V	25°C	91	110	mΩ	
				-40°C to 85°C				125
				-40°C to 125°C				140
R_{ON}	ON-State Resistance	IOUT = -200 mA	VIN = 1.8 V	25°C	141	180	mΩ	
				-40°C to 85°C				210
				-40°C to 125°C				230
Comparator Chip Enable (CE)								
V_{ON}	Turn ON Threshold	VCE - VIN	-40°C to 125°C	-250	-150	-80	mV	
V_{OFF}	Turn OFF Threshold	VCE - VIN	-40°C to 125°C	0	35	80	mV	
I_{CE}	CE Pin Leakage Current	VCE < VIN - 250mV	-40°C to 125°C	0	160	300	nA	
I_{CE}	CE Pin Leakage Current	VCE > VIN + 80mV	-40°C to 125°C	0	400	610	nA	
Reverse Current Blocking (RCB) and Body Diode Characteristics								
I_{RCB}	Reverse Activation Current	VCE = VOUT	-40°C to 125°C	0.5	1		A	
V_{FWD}	Body Diode Forward Voltage	IOUT = 10 mA VCE > VIN + 80mV	-40°C to 125°C	0.1	0.5	1.1	V	
Status Indication (ST)								
$V_{OL, ST}$	Output Low Voltage	IST = 1 mA	-40°C to 125°C			0.1	V	
t_{ST}	Status Delay Time	VCE transitions from low to high	-40°C to 125°C		1		μs	
I_{ST}	ST Pin Leakage Current	VCE < VIN - 250mV	-40°C to 125°C	-20		20	nA	

6.6 Switching Characteristics

Unless otherwise noted, the typical characteristics in the following table applies over the entire recommended operating voltage at an ambient temperature of 25°C and a load of $C_L = 100$ nF and $R_L = 1$ kΩ

PARAMETER		TEST CONDITIONS		MIN	TYP	MAX	UNIT
t_{ON}	Turn ON Time	VIN = 1.8 V			90		μs
		VIN = 3.6 V			40		μs
		VIN = 5 V			27		μs
t_{OFF}	Turn OFF Time	VIN = 1.8 V			2		μs
		VIN = 3.6 V			2		μs
		VIN = 5 V			2		μs

Switching Characteristics (continued)

Unless otherwise noted, the typical characteristics in the following table applies over the entire recommended operating voltage at an ambient temperature of 25°C and a load of $C_L = 100$ nF and $R_L = 1$ k Ω

PARAMETER	TEST CONDITIONS	MIN	TYP	MAX	UNIT
t_{FALL}	$V_{IN} = 1.8$ V		20		μ s
	$V_{IN} = 3.6$ V		10		μ s
	$V_{IN} = 5$ V		7.5		μ s

6.7 Typical Characteristics

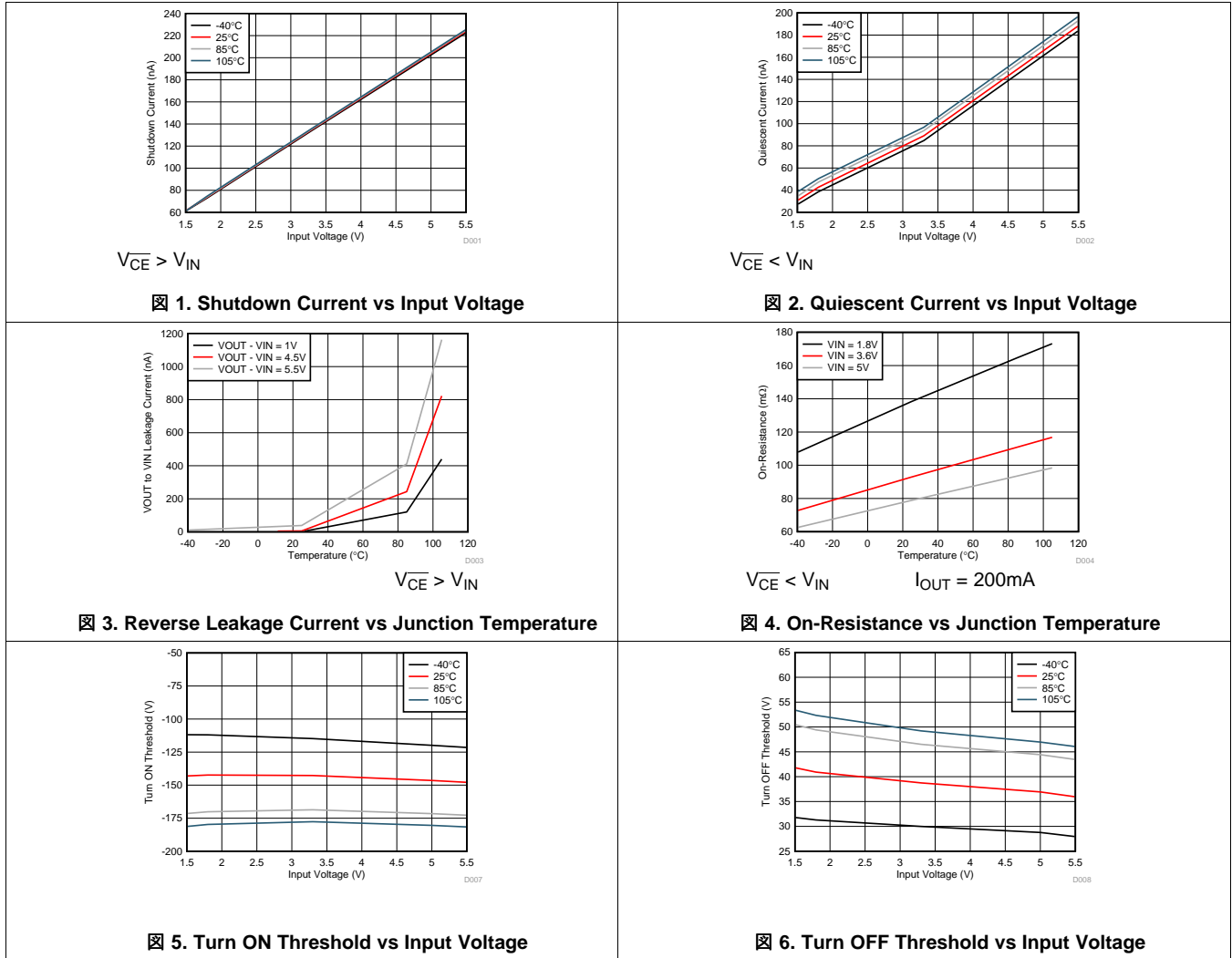

Typical Characteristics (continued)

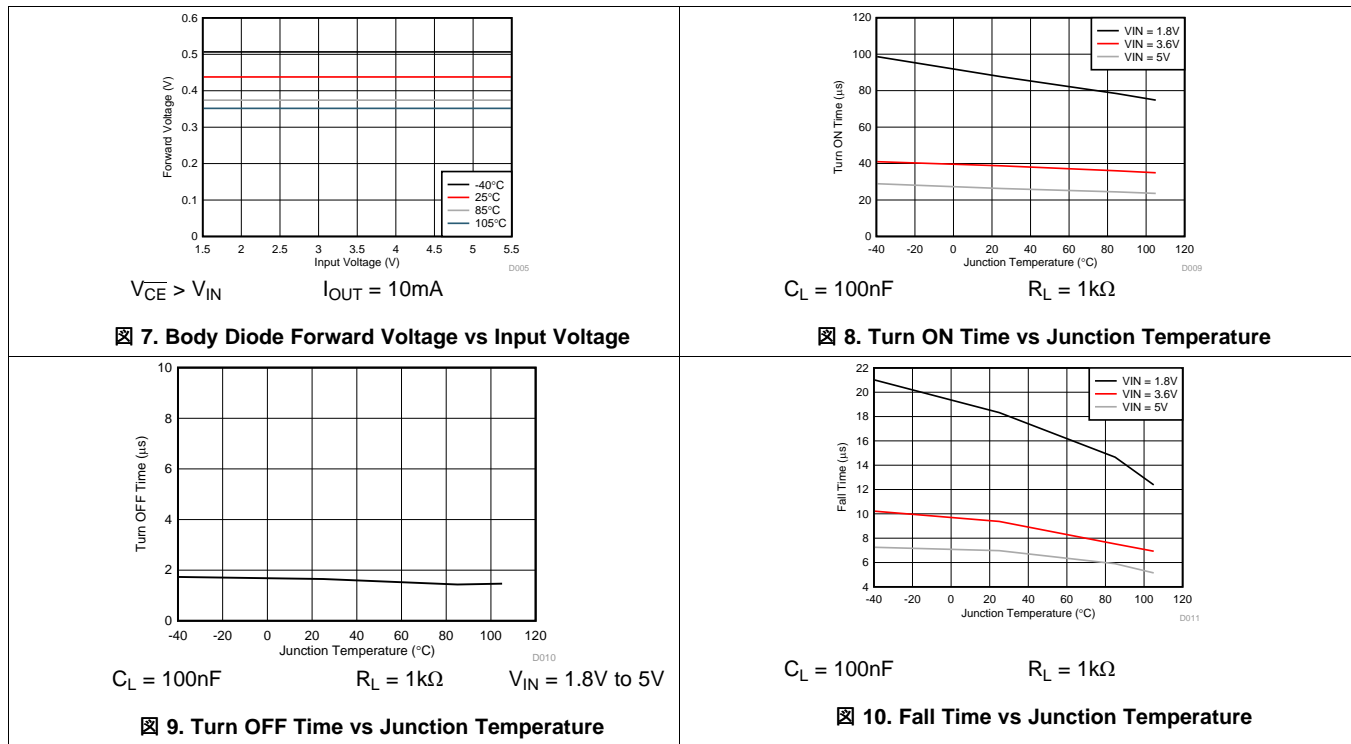

7 Parameter Measurement Information

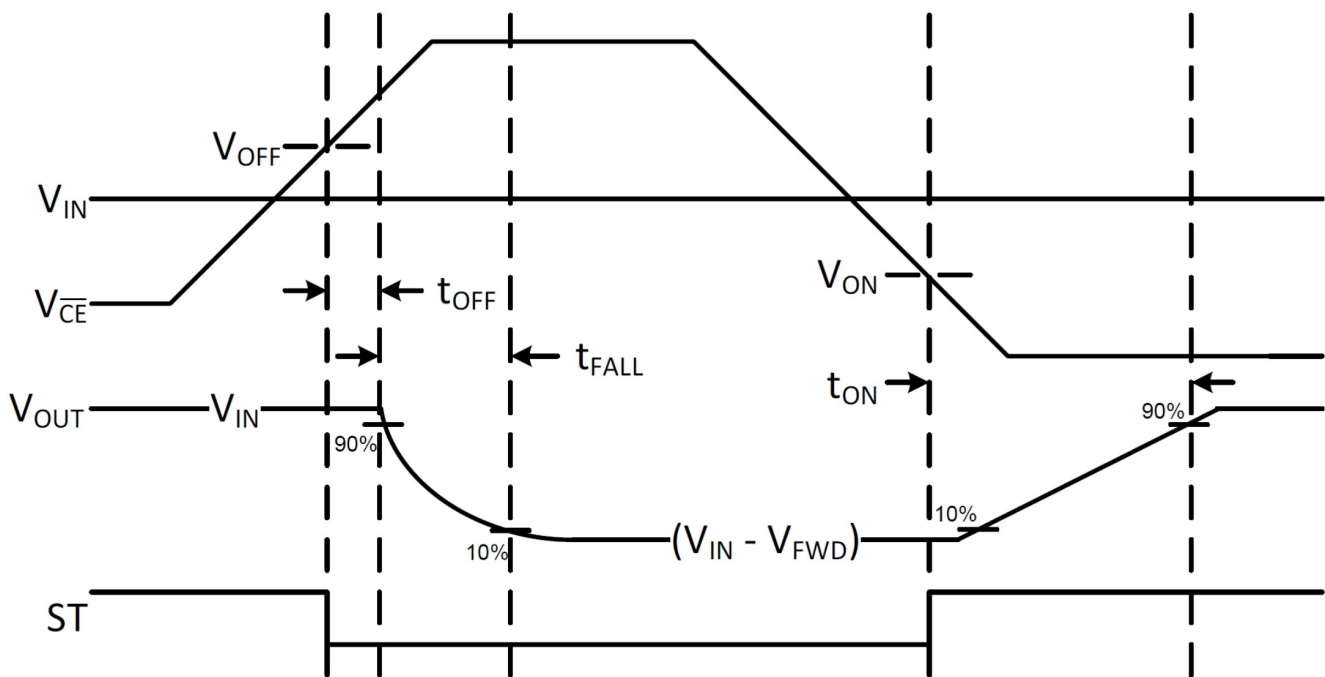

Figure 11. Timing Diagram

8 Detailed Description

8.1 Overview

The LM66100 is a Single-Input, Single-Output (SISO) integrated ideal diode that is well suited for a variety of applications. The device contains a P-channel MOSFET that can operate over an input voltage range of 1.5 V to 5.5 V and can support a maximum continuous current of 1.5 A.

The chip enable works by comparing the \overline{CE} pin voltage to the input voltage. When the \overline{CE} pin voltage is higher than V_{IN} by 80 mV, the device is disabled and the MOSFET is off. When the \overline{CE} pin voltage is lower than V_{IN} by 250 mV, the MOSFET is on. The LM66100 also comes with reverse polarity protection (RPP) that can protect the device from a miswired input, such as a reversed battery.

8.2 Functional Block Diagram

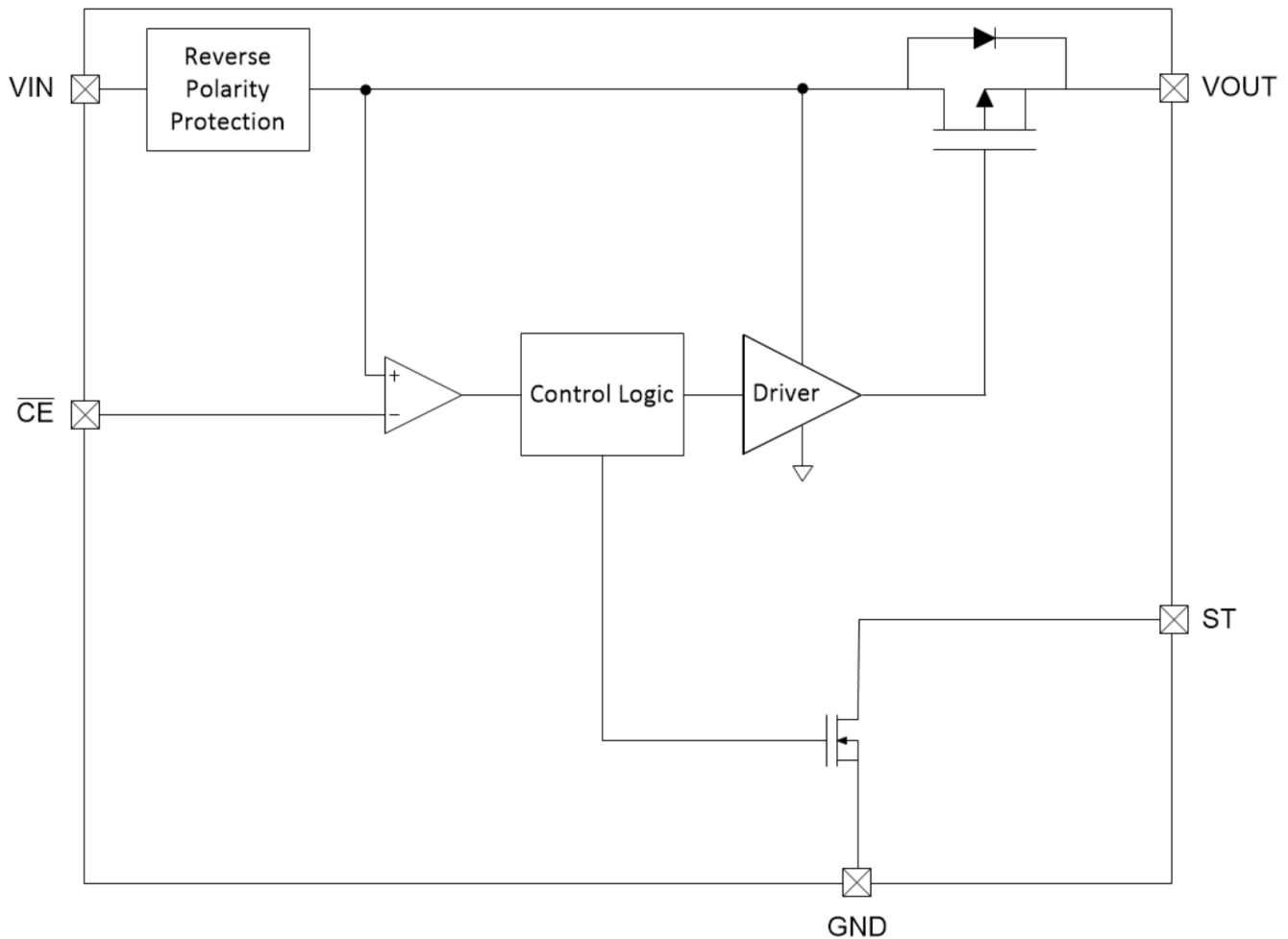

8.3 Feature Description

8.3.1 Reverse Polarity Protection (RPP)

In the event a negative input voltage is applied, the ideal diode will stay off and prevent current flow to protect the system load. For a stand-alone, always on application, \overline{CE} can be tied to GND so it will not go negative with respect to GND see [Figure 12](#).

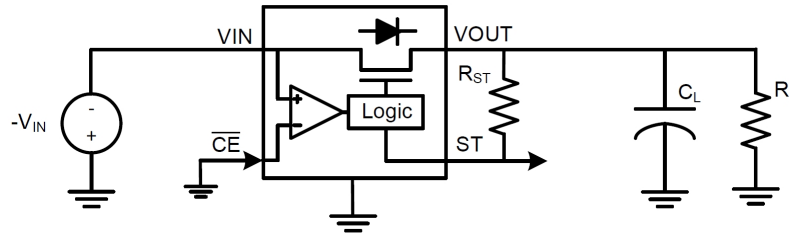

Figure 12. RPP Protection Circuit

8.3.2 Always-ON Reverse Current Blocking (RCB)

By connecting the \overline{CE} pin to V_OUT, this allows the comparator to detect reverse current flow through the switch. If the output is forced above the selected input by V_{OFF} , the channel will switch off to stop the reverse current I_{RCB} within t_{OFF} . Once the output falls to below V_{IN} by V_{ON} , the device will turn back on.

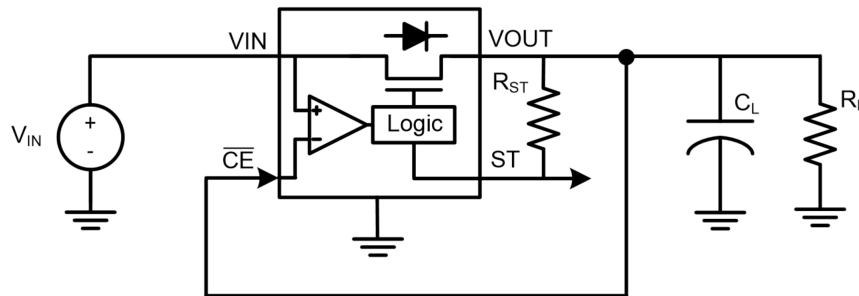

Figure 13. RCB Circuit

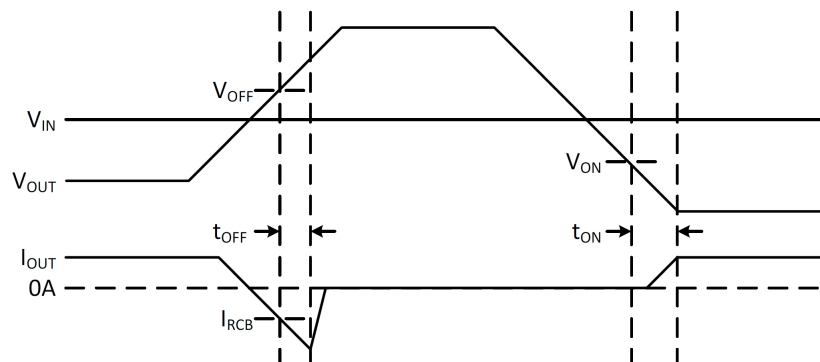

Figure 14. RCB Waveforms

8.4 Device Functional Modes

表 1 summarizes the Device Functional Modes:

表 1. Device Functional Modes

State	IN-to-OUT	Power Dissipation	ST State
OFF	Diode	$I_{OUT} \times V_{FWD}$	L
ON	Switch	$I_{OUT}^2 \times R_{ON}$	H

9 Application and Implementation

注

Information in the following applications sections is not part of the TI component specification, and TI does not warrant its accuracy or completeness. TI's customers are responsible for determining suitability of components for their purposes. Customers should validate and test their design implementation to confirm system functionality.

9.1 Application Information

The LM66100 Ideal Diode can be used in a variety of stand-alone and multi-channel applications.

9.2 Typical Applications

9.2.1 Dual Ideal Diode ORing

Two LM66100 Ideal Diodes can be used together for ORing between two power supplies.



图 15. Dual Ideal Diode ORing

9.2.1.1 Design Requirements

Design a circuit that allows the highest input voltage to power a downstream system while providing reverse current protection.

9.2.1.2 Detailed Design Procedure

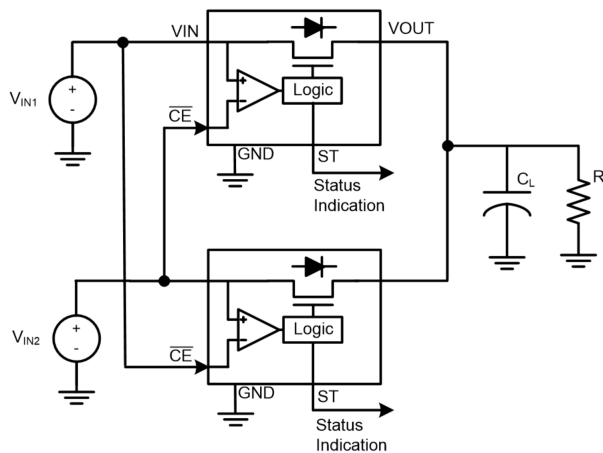
This circuit ties the \overline{CE} of each device to the opposite power source. In this configuration, the highest supply will always be selected using a make-before-break logic. This prevents any reverse current flow between the supplies and avoids the need of a dedicated reverse current blocking comparator. For ORing applications that need RPP, it is recommended to use a series resistor ($R_{\overline{CE}}$) to limit the current into the \overline{CE} pin during a negative voltage event.

Typical Applications (continued)

9.2.1.3 Application Curves

The below scope shot shows the output voltage (VOUT) being initially powered by VIN1. When VIN2 is applied, it powers VOUT because it is a higher voltage. When VIN2 is removed, VOUT is once again powered by VIN1.

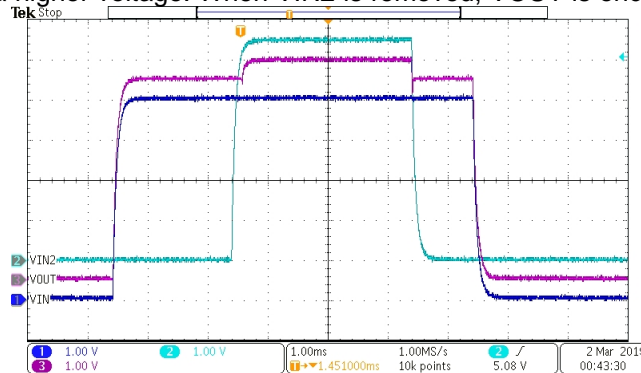

Figure 16. Dual Ideal Diode ORing Behavior

9.2.2 Dual Ideal Diode ORing for Continuous Output Power

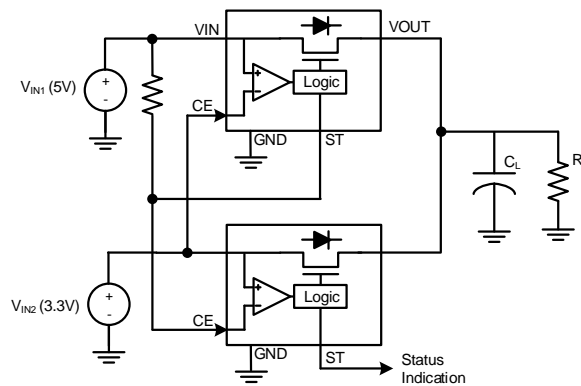

Figure 17. Dual Ideal Diode ORing for Continuous Output Power

9.2.2.1 Design Requirements

The shortcoming of the previous implementation happens when both input voltages are the same for a long period of time, then both devices will completely turn off, powering down the output load. To avoid this case, the status output from the priority supply and a pull up resistor can be used causing both devices to switchover at the same time. For ORing applications that need RPP, it is recommended to use a series resistor (R_{CE}) to limit the current into the CE pin during a negative voltage event.

Typical Applications (continued)

9.2.2.2 Application Curves

The figures below show the switchover performance between VIN1 and VIN2.

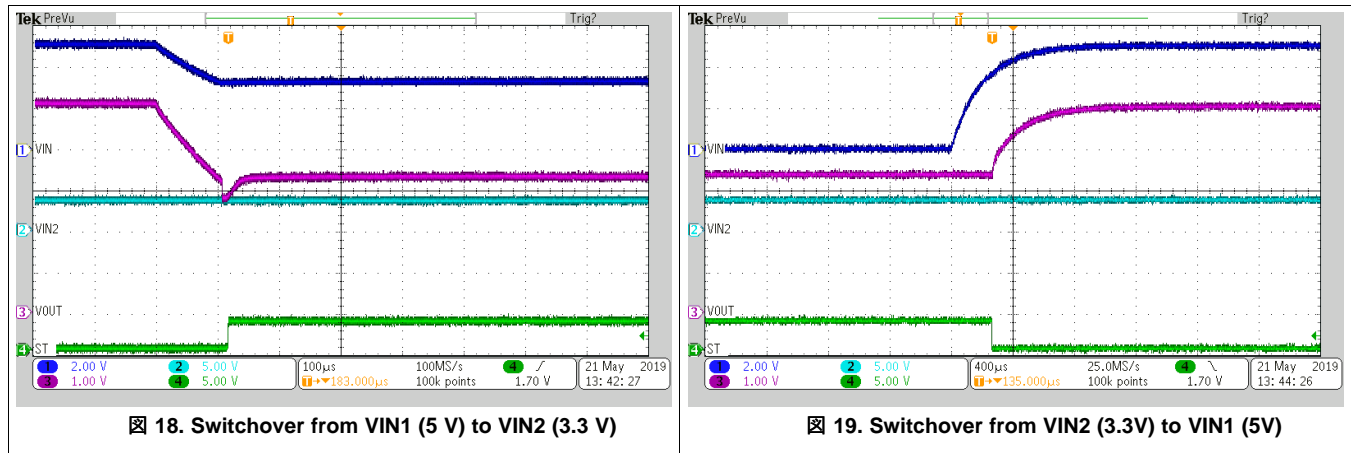

9.2.3 ORing with Discrete MOSFET



图 20. ORing with a Discrete MOSFET

9.2.3.1 Design Requirements

Similar to the Dual Ideal Diode circuit, the Status Output can also be used to control a discrete P-Channel MOSFET. This can be useful in applications that want to minimize the leakage current on the secondary supply, such as battery backup systems. This configuration can also be used on systems that require a lower RON on the secondary rail, useful for higher current applications.

When the Ideal Diode path is enabled, the status will be Hi-Z and pull up the gate of the external PFET to keep it off. When the main supply (VIN1) drops such that backup supply (VIN2) is higher than VIN1, the ideal diode will be disabled and pull the ST pin and the PFET gate low to turn on the discrete MOSFET path.

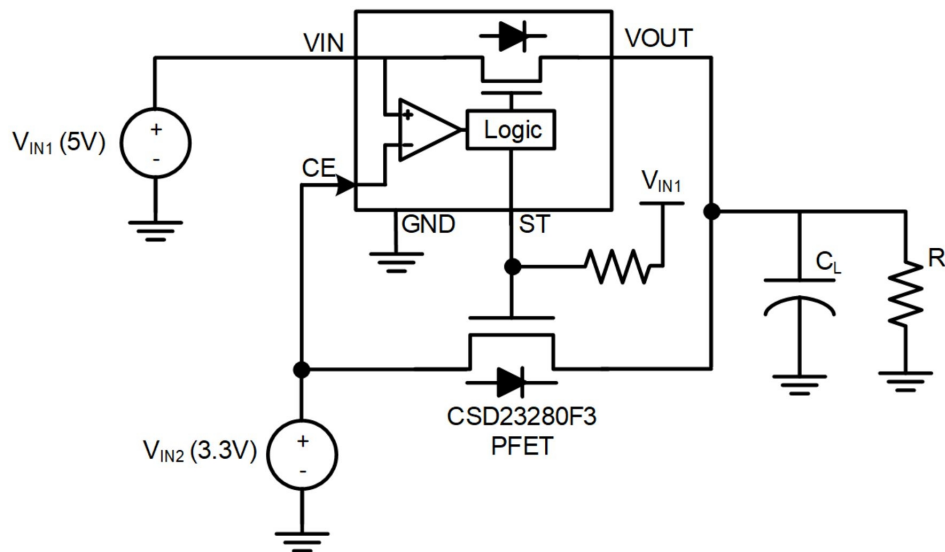
Typical Applications (continued)

9.2.3.2 Application Curves

The figures below show the switchover performance between VIN1 and VIN2.

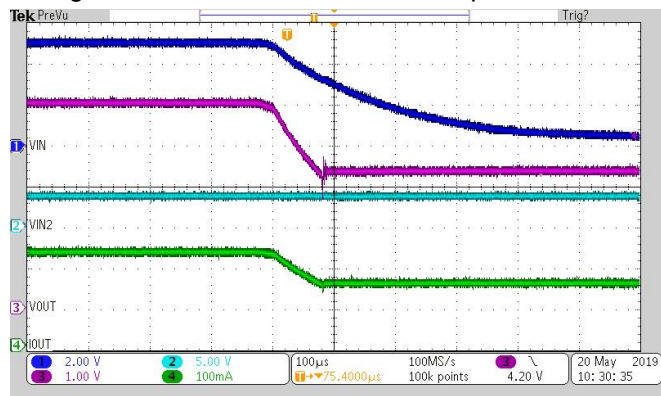

Figure 21. Switchover from VIN1 5 V to VIN2 3.3 V

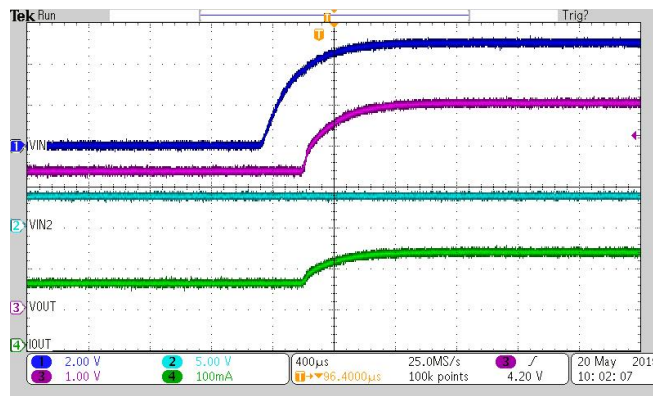

Figure 22. Switchover from VIN2 3.3 V to VIN1 5 V

10 Power Supply Recommendations

The device is designed to operate with a VIN range of 1.5 V to 5.5 V. The VIN power supply must be well regulated and placed as close to the device terminal as possible. The power supply must be able to withstand all transient load current steps. In most situations, using an input capacitance (CIN) of 1 µF is sufficient to prevent the supply voltage from dipping when the switch is turned on. In cases where the power supply is slow to respond to a large transient current or large load current step, additional bulk capacitance may be required on the input.

11 Layout

11.1 Layout Guidelines

For best performance, all traces must be as short as possible. To be most effective, the input and output capacitors must be placed close to the device to minimize the effects that parasitic trace inductances may have on normal operation. Using wide traces for VIN, VOUT and GND helps minimize the parasitic electrical effects.

11.2 Layout Example

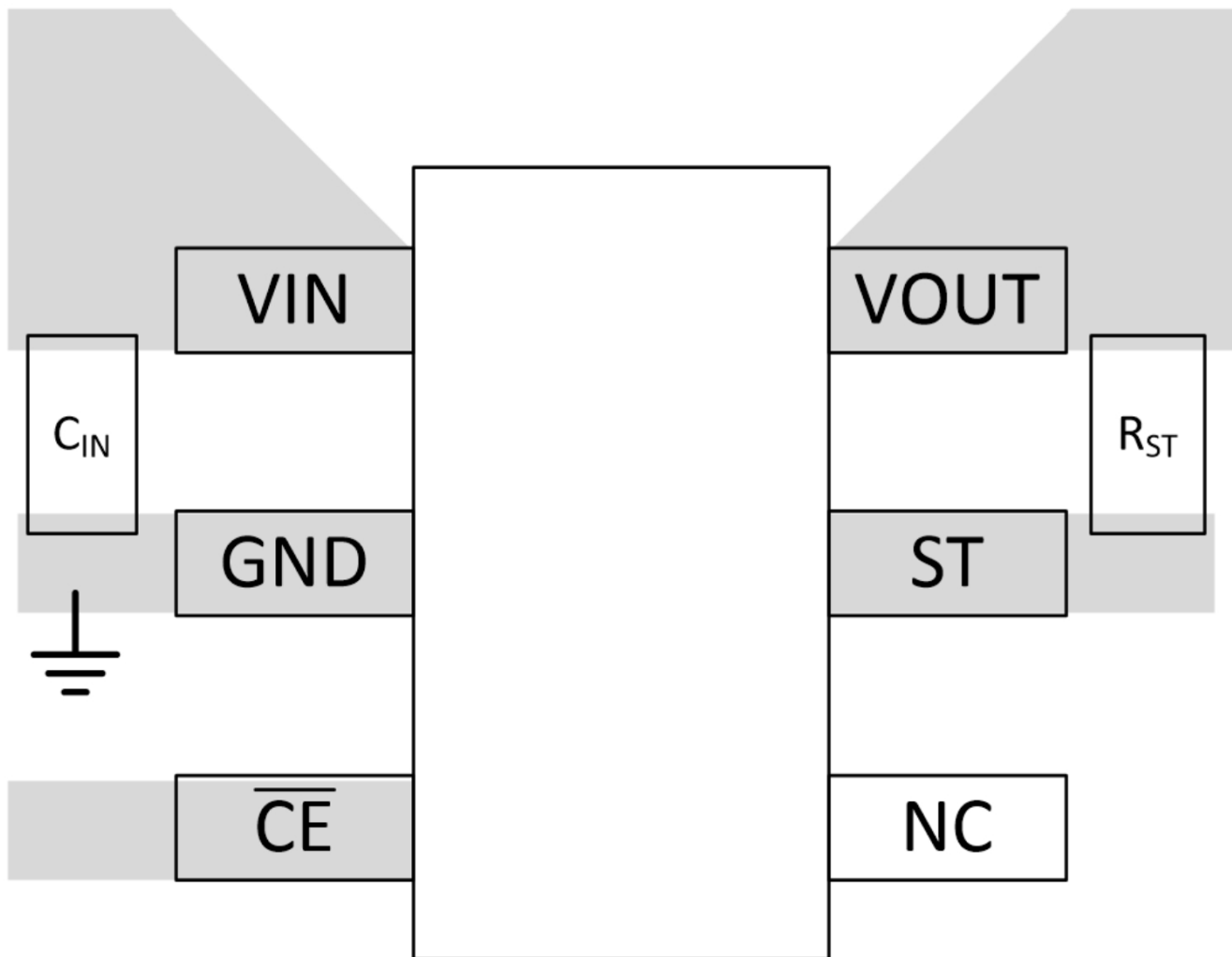

☒ 23. LM66100 Layout Example

12 デバイスおよびドキュメントのサポート

12.1 ドキュメントの更新通知を受け取る方法

ドキュメントの更新についての通知を受け取るには、ti.comのデバイス製品フォルダを開いてください。右上の「アラートを受け取る」をクリックして登録すると、変更されたすべての製品情報に関するダイジェストを毎週受け取れます。変更の詳細については、修正されたドキュメントに含まれている改訂履歴をご覧ください。

12.2 コミュニティ・リソース

The following links connect to TI community resources. Linked contents are provided "AS IS" by the respective contributors. They do not constitute TI specifications and do not necessarily reflect TI's views; see TI's [Terms of Use](#).

TI E2E™ Online Community *TI's Engineer-to-Engineer (E2E) Community*. Created to foster collaboration among engineers. At e2e.ti.com, you can ask questions, share knowledge, explore ideas and help solve problems with fellow engineers.

Design Support *TI's Design Support* Quickly find helpful E2E forums along with design support tools and contact information for technical support.

12.3 商標

E2E is a trademark of Texas Instruments.

12.4 静電気放電に関する注意事項



すべての集積回路は、適切なESD保護方法を用いて、取扱いと保存を行うようにして下さい。

静電気放電はわずかな性能の低下から完全なデバイスの故障に至るまで、様々な損傷を与えます。高精度の集積回路は、損傷に対して敏感であり、極めてわずかなパラメータの変化により、デバイスに規定された仕様に適合しなくなる場合があります。

12.5 Glossary

SLYZ022 — *TI Glossary*.

This glossary lists and explains terms, acronyms, and definitions.

13 メカニカル、パッケージ、および注文情報

以降のページには、メカニカル、パッケージ、および注文に関する情報が記載されています。この情報は、そのデバイスについて利用可能な最新のデータです。このデータは予告なく変更されることがあり、ドキュメントが改訂される場合もあります。本データシートのブラウザ版を使用されている場合は、画面左側の説明をご覧ください。

PACKAGING INFORMATION

Orderable Device	Status (1)	Package Type	Package Drawing	Pins	Package Qty	Eco Plan (2)	Lead finish/ Ball material (6)	MSL Peak Temp (3)	Op Temp (°C)	Device Marking (4/5)	Samples
LM66100DCKR	ACTIVE	SC70	DCK	6	3000	RoHS & Green	SN	Level-1-260C-UNLIM	-40 to 125	1CU	Samples
LM66100DCKT	ACTIVE	SC70	DCK	6	250	RoHS & Green	SN	Level-1-260C-UNLIM	-40 to 105	1CU	Samples

(1) The marketing status values are defined as follows:

ACTIVE: Product device recommended for new designs.

LIFEBUY: TI has announced that the device will be discontinued, and a lifetime-buy period is in effect.

NRND: Not recommended for new designs. Device is in production to support existing customers, but TI does not recommend using this part in a new design.

PREVIEW: Device has been announced but is not in production. Samples may or may not be available.

OBSELETE: TI has discontinued the production of the device.

(2) **RoHS:** TI defines "RoHS" to mean semiconductor products that are compliant with the current EU RoHS requirements for all 10 RoHS substances, including the requirement that RoHS substance do not exceed 0.1% by weight in homogeneous materials. Where designed to be soldered at high temperatures, "RoHS" products are suitable for use in specified lead-free processes. TI may reference these types of products as "Pb-Free".

RoHS Exempt: TI defines "RoHS Exempt" to mean products that contain lead but are compliant with EU RoHS pursuant to a specific EU RoHS exemption.

Green: TI defines "Green" to mean the content of Chlorine (Cl) and Bromine (Br) based flame retardants meet JS709B low halogen requirements of <=1000ppm threshold. Antimony trioxide based flame retardants must also meet the <=1000ppm threshold requirement.

(3) MSL, Peak Temp. - The Moisture Sensitivity Level rating according to the JEDEC industry standard classifications, and peak solder temperature.

(4) There may be additional marking, which relates to the logo, the lot trace code information, or the environmental category on the device.

(5) Multiple Device Markings will be inside parentheses. Only one Device Marking contained in parentheses and separated by a "~" will appear on a device. If a line is indented then it is a continuation of the previous line and the two combined represent the entire Device Marking for that device.

(6) Lead finish/Ball material - Orderable Devices may have multiple material finish options. Finish options are separated by a vertical ruled line. Lead finish/Ball material values may wrap to two lines if the finish value exceeds the maximum column width.

Important Information and Disclaimer:The information provided on this page represents TI's knowledge and belief as of the date that it is provided. TI bases its knowledge and belief on information provided by third parties, and makes no representation or warranty as to the accuracy of such information. Efforts are underway to better integrate information from third parties. TI has taken and continues to take reasonable steps to provide representative and accurate information but may not have conducted destructive testing or chemical analysis on incoming materials and chemicals. TI and TI suppliers consider certain information to be proprietary, and thus CAS numbers and other limited information may not be available for release.

In no event shall TI's liability arising out of such information exceed the total purchase price of the TI part(s) at issue in this document sold by TI to Customer on an annual basis.

TAPE AND REEL INFORMATION

QUADRANT ASSIGNMENTS FOR PIN 1 ORIENTATION IN TAPE

*All dimensions are nominal

Device	Package Type	Package Drawing	Pins	SPQ	Reel Diameter (mm)	Reel Width W1 (mm)	A0 (mm)	B0 (mm)	K0 (mm)	P1 (mm)	W (mm)	Pin1 Quadrant
LM66100DCKR	SC70	DCK	6	3000	180.0	8.4	2.3	2.5	1.2	4.0	8.0	Q3
LM66100DCKT	SC70	DCK	6	250	180.0	8.4	2.3	2.5	1.2	4.0	8.0	Q3

TAPE AND REEL BOX DIMENSIONS

*All dimensions are nominal

Device	Package Type	Package Drawing	Pins	SPQ	Length (mm)	Width (mm)	Height (mm)
LM66100DCKR	SC70	DCK	6	3000	210.0	185.0	35.0
LM66100DCKT	SC70	DCK	6	250	210.0	185.0	35.0



LAND PATTERN EXAMPLE
EXPOSED METAL SHOWN
SCALE:18X

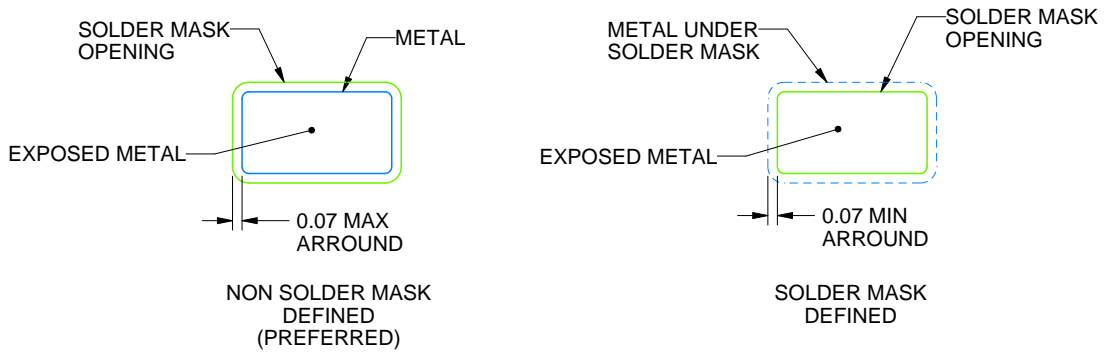

SOLDER MASK DETAILS

4214835/D 11/2024

NOTES: (continued)

- 5. Publication IPC-7351 may have alternate designs.
- 6. Solder mask tolerances between and around signal pads can vary based on board fabrication site.

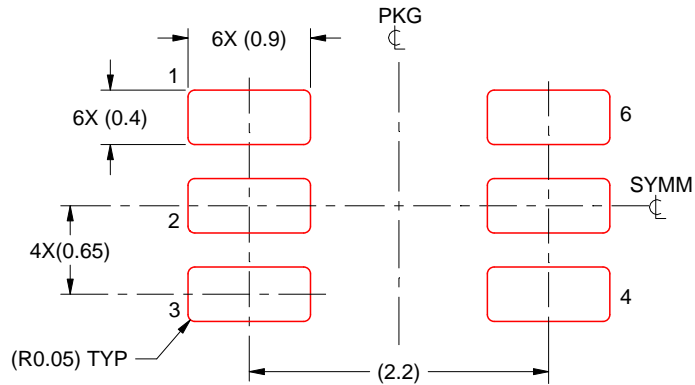

SOLDER PASTE EXAMPLE
BASED ON 0.125 THICK STENCIL
SCALE:18X

4214835/D 11/2024

NOTES: (continued)

7. Laser cutting apertures with trapezoidal walls and rounded corners may offer better paste release. IPC-7525 may have alternate design recommendations.
8. Board assembly site may have different recommendations for stencil design.

重要なお知らせと免責事項

テキサス・インスツルメンツは、技術データと信頼性データ(データシートを含みます)、設計リソース(リファレンス デザインを含みます)、アプリケーションや設計に関する各種アドバイス、Web ツール、安全性情報、その他のリソースを、欠陥が存在する可能性のある「現状のまま」提供しており、商品性および特定目的に対する適合性の黙示保証、第三者の知的財産権の非侵害保証を含むいかなる保証も、明示的または黙示的にかかわらず拒否します。

これらのリソースは、テキサス・インスツルメンツ製品を使用する設計の経験を積んだ開発者への提供を意図したものです。(1) お客様のアプリケーションに適したテキサス・インスツルメンツ製品の選定、(2) お客様のアプリケーションの設計、検証、試験、(3) お客様のアプリケーションに該当する各種規格や、その他のあらゆる安全性、セキュリティ、規制、または他の要件への確実な適合に関する責任を、お客様のみが単独で負うものとし、ます。

上記の各種リソースは、予告なく変更される可能性があります。これらのリソースは、リソースで説明されているテキサス・インスツルメンツ製品を使用するアプリケーションの開発の目的でのみ、テキサス・インスツルメンツはその使用をお客様に許諾します。これらのリソースに関して、他の目的で複製することや掲載することは禁止されています。テキサス・インスツルメンツや第三者の知的財産権のライセンスが付与されている訳ではありません。お客様は、これらのリソースを自身で使用した結果発生するあらゆる申し立て、損害、費用、損失、責任について、テキサス・インスツルメンツおよびその代理人を完全に補償するものとし、テキサス・インスツルメンツは一切の責任を拒否します。

テキサス・インスツルメンツの製品は、[テキサス・インスツルメンツの販売条件](#)、または [ti.com](https://www.ti.com) やかかるテキサス・インスツルメンツ製品の関連資料などのいずれかを通じて提供する適用可能な条項の下で提供されています。テキサス・インスツルメンツがこれらのリソースを提供することは、適用されるテキサス・インスツルメンツの保証または他の保証の放棄の拡大や変更を意味するものではありません。

お客様がいかなる追加条項または代替条項を提案した場合でも、テキサス・インスツルメンツはそれらに異議を唱え、拒否します。

郵送先住所：Texas Instruments, Post Office Box 655303, Dallas, Texas 75265
Copyright © 2025, Texas Instruments Incorporated