

LMG2100R026 100V、53A GaN ハーフブリッジ電力段

1 特長

- 統合されたハーフブリッジ GaN FET およびドライバ
- 電圧定格:連続 93V、パルス 100V
- 簡単に PCB をレイアウトするよう最適化されたパッケージ
- 低リンギングで、高スルーレートのスイッチング
- 5V の外部バイアス電源
- 3.3V および 5V の入力ロジックレベルをサポート
- ゲートドライバは最高 10MHz のスイッチングが可能
- 非常に優れた伝搬遅延 (標準値 33ns) およびマッチング (標準値 2ns)
- 内部的なブートストラップ電源電圧クランピングにより、GaN FET オーバードライブを防止
- 電源レールの低電圧誤動作防止保護
- 低消費電力
- 上面冷却用の露出上面 QFN パッケージ
- 底面冷却用の大型 GND パッド

2 アプリケーション

- 降圧、昇圧、昇降圧コンバータ
- LLC コンバータ
- 太陽光インバータ
- テレコムとサーバー電源
- モータードライブ
- 電動工具
- Class-D オーディオ アンプ

3 概要

LMG2100R026 デバイスは、93V 連続、100V パルス、53A ハーフブリッジ電力段で、ゲートドライバとエンハンスメントモードの窒化ガリウム (GaN) FET が内蔵されています。このデバイスは 2 つの GaN FET で構成され、1 つの高周波数 GaN FET ドライバによりハーフブリッジ構成で駆動されます。

GaN FET は逆方向回復時間がゼロで、入力容量 C_{ISS} および出力容量 C_{OSS} が非常に小さいため、電力変換において大きな利点があります。ドライバと 2 つの GaN FET はボンドワイヤを一切使用しないパッケージプラットフォームに取り付けられ、パッケージの寄生要素は最小限に抑えられます。The LMG2100R026 デバイスは、7.0mm × 4.5mm × 0.89mm の鉛フリーパッケージで供給され、簡単に PCB へ実装できます。

TTL ロジック互換の入力は、VCC 電圧にかかわらず 3.3V および 5V のロジックレベルをサポートできます。独自のブートストラップ電圧クランピング技法により、エンハンスメントモード GaN FET のゲート電圧が安全な動作範囲内であることが保証されます。

このデバイスは、ディスクリート GaN FET に対してより使いやすいインターフェイスを提供し、その利点を拡大します。小さなフォームファクタで高周波数、高効率の動作が必要なアプリケーションに理想的なソリューションです。

パッケージ情報

部品番号	パッケージ (1)	パッケージサイズ (2)
LMG2100R026	VBN (VQFN, 18)	7.00mm × 4.50mm

- (1) 供給されているすべてのパッケージについては、[セクション 11](#) を参照してください。
- (2) パッケージサイズ (長さ × 幅) は公称値であり、該当する場合はピンも含まれます。

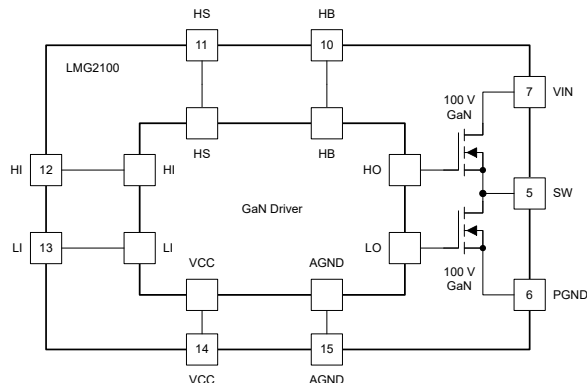

概略ブロック図



Table of Contents

1 特長	1	7.4 Device Functional Modes.....	14
2 アプリケーション	1	8 Application and Implementation	14
3 概要	1	8.1 Application Information.....	14
4 Pin Configuration and Functions	3	8.2 Typical Application.....	14
5 Specifications	4	8.3 Power Supply Recommendations.....	18
5.1 Absolute Maximum Ratings.....	4	8.4 Layout.....	19
5.2 ESD Ratings.....	4	9 Device and Documentation Support	21
5.3 Recommended Operating Conditions.....	4	9.1 Documentation Support.....	21
5.4 Thermal Information.....	5	9.2 Receiving Notification of Documentation Updates....	21
5.5 Electrical Characteristics.....	5	9.3 サポート・リソース.....	21
5.6 Typical Characteristics.....	7	9.4 Trademarks.....	21
6 Parameter Measurement Information	9	9.5 静電気放電に関する注意事項.....	21
6.1 Propagation Delay and Mismatch Measurement.....	9	9.6 用語集.....	21
7 Detailed Description	11	10 Revision History	21
7.1 Overview.....	11	11 Mechanical, Packaging, and Orderable Information	22
7.2 Functional Block Diagram.....	11	11.1 Package Information.....	22
7.3 Feature Description.....	12		

4 Pin Configuration and Functions



图 4-1. VBN Package, 18-Pin VQFN (Top View)

表 4-1. Pin Functions

PIN		I/O ⁽¹⁾	DESCRIPTION
NAME	NO.		
NC	1–4, 8, 9, 16	—	Not connected internally. Leave floating.
SW	5	P	Switching node. Internally connected to HS pin.
PGND	6, 17, 18	G	Power ground. Low-side GaN FET source. Internally connected to low-side GaN FET source.
VIN	7	P	Input voltage pin. Internally connected to high-side GaN FET drain.
HB	10	P	High-side gate driver bootstrap rail. Connect bypass capacitor to HS.
HS	11	P	High-side GaN FET source connection.
HI	12	I	High-side gate driver control input.
LI	13	I	Low-side gate driver control input.
VCC	14	P	5V device power supply.
AGND	15	G	Analog ground. Internally connected to low-side GaN FET source.

(1) I = Input, O = Output, G = Ground, P = Power

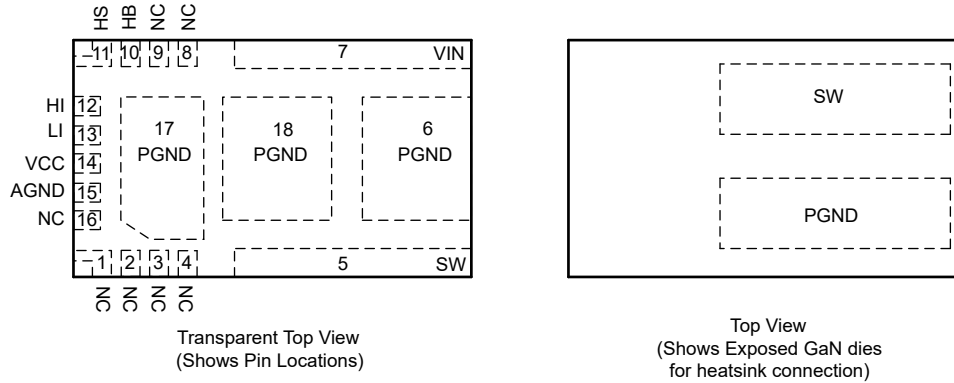
5 Specifications

5.1 Absolute Maximum Ratings

See⁽¹⁾

	MIN	MAX	UNIT
VIN to PGND	0	93	V
VIN to PGND (pulsed, 100-ms max duration) ⁽²⁾		100	V
HB to AGND	-0.3	100	V
HS to AGND		93	V
HS to AGND (pulsed, 100-ms max duration) ⁽²⁾		100	V
HI to AGND	-0.3	6	V
LI to AGND	-0.3	6	V
VCC to AGND	-0.3	6	V
HB to HS	-0.3	6	V
HB to VCC	0	93	V
SW to PGND		93	V
IOUT from SW pin (Continuous), $T_J < 125^\circ\text{C}$		55	A
IOUT from SW pin (Pulsed, 300 μs), $T_A = 25^\circ\text{C}$		218	A
Junction Temperature, T_J	-40	150	$^\circ\text{C}$
Storage Temperature, T_{stg}	-40	150	$^\circ\text{C}$

- (1) Operation outside the Absolute Maximum Ratings may cause permanent device damage. Absolute Maximum Ratings do not imply functional operation of the device at these or any other conditions beyond those listed under Recommended Operating Conditions. If used outside the Recommended Operating Conditions but within the Absolute Maximum Ratings, the device may not be fully functional, and this may affect device reliability, functionality, performance, and shorten the device lifetime.
- (2) Device can withstand 1000 pulses up to 100V of 100ms duration and less than 1% duty cycle over its lifetime.

5.2 ESD Ratings

		VALUE	UNIT	
$V_{\text{(ESD)}}$	Electrostatic Discharge	Human-body model (HBM), per ANSI/ESDA/ JEDEC JS-001 ⁽¹⁾	± 500	V
		Charged-device model (CDM), per JEDEC specification JESD22-C101 ⁽²⁾	± 500	V

- (1) JEDEC document JEP155 states that 500-V HBM allows safe manufacturing with a standard ESD control process.
- (2) JEDEC document JEP157 states that 250-V CDM allows safe manufacturing with a standard ESD control process.

5.3 Recommended Operating Conditions

Unless otherwise noted, voltages are with respect to AGND

	MIN	NOM	MAX	UNIT
VCC	4.75	5	5.25	V
LI or HI Input	0		5.5	V
HB	$V_{\text{HS}} + 4$		$V_{\text{HS}} + 5.25$	V
HS, SW Slew rate ⁽¹⁾			50	V/ns

- (1) Determined through design and characterization. Not tested in production.

5.4 Thermal Information

THERMAL METRIC ⁽¹⁾		LMG2100	UNIT
		QFN	
		18 PINS	
R _{θJA}	Junction-to-ambient thermal resistance	27	°C/W
R _{θJC(top)}	Junction-to-case (top) thermal resistance	0.4	°C/W
R _{θJC(Bot)}	Junction-to-case (bottom) thermal resistance, low-side FET to PGND	5.4	°C/W
	Junction-to-case (bottom) thermal resistance, high-side FET to VIN	6.3	°C/W
R _{θJB}	Junction-to-board thermal resistance	3.9	°C/W
ψ _{JT}	Junction-to-top characterization parameter	1.7	°C/W
ψ _{JB}	Junction-to-board characterization parameter	3.8	°C/W

(1) For more information about traditional and new thermal metrics, see the *IC Package Thermal Metrics* application report, [SPRA953](#).

5.5 Electrical Characteristics

Unless otherwise noted, voltages are with respect to AGND; -40°C ≤ T_J ≤ 125°C⁽¹⁾

PARAMETER		TEST CONDITIONS	MIN	TYP	MAX	UNIT
POWER STAGE						
R _{DS(ON)HS}	High-side GaN FET on-resistance	LI=0V, HI=VCC=5V, HB-HS=5V, I(VIN-SW)=16A, T _J = 25°C		2.7	3.5	mΩ
R _{DS(ON)LS}	Low-side GaN FET on-resistance	LI=VCC=5V, HI=0V, HB-HS=5V, I(SW-PGND)=16A, T _J = 25°C		2.6	3.5	mΩ
V _{SD}	GaN 3rd quadrant conduction drop	I _{SD} = 500 mA, V _{IN} floating, VCC = 5 V, HI = LI = 0V		1.5		V
I _{L-VIN-SW}	Leakage from VIN to SW when the high-side GaN FET and low-side GaN FET are off	VIN = 80V, SW=0, HI = LI = 0V, VCC = 5V, T _J =25°C		10	160	μA
I _{L-SW-GND}	Leakage from SW to GND when the high-side GaN FET and low-side GaN FET are off	SW = 80V, HI = LI = 0V, VCC = 5V, T _J =25°C		10	160	μA
C _{ISS}	Input Capacitance of high side or low side HEMT	V _{DS} =50V, V _{GS} = 0V (HI = LI = 0V)		1686		pF
C _{OSS}	Output Capacitance of high-side GaN FET or low-side GaN FET	V _{DS} =50V, V _{GS} = 0V (HI = LI = 0V)		570	790	pF
C _{OSS(ER)}	Output Capacitance of high-side GaN FET or low-side GaN FET - Energy Related	V _{DS} =0 to 50V, V _{GS} = 0V (HI = LI = 0V)		700		pF
C _{OSS(TR)}	Output Capacitance of high-side GaN FET or low-side GaN FET - Time Related	V _{DS} =0 to 50V, V _{GS} = 0V (HI = LI = 0V)		881		pF
C _{WELL}	HV-Well Capacitance (SW to PGND)	V _{IN} =V _{SW} =50V, HI = LI = 0V		30		pF
C _{RSS}	Reverse Transfer Capacitance of high side or low side HEMT	V _{DS} =50V, V _{GS} = 0V (HI = LI = 0V)		4.3		pF
Q _G	Total Gate Charge of high side or low side HEMT	V _{DS} =50V, I _D = 16A, V _{GS} = 5V		12	15.8	nC
Q _{GD}	Gate to Drain Charge of high side or low side HEMT	V _{DS} =50V, I _D = 16A		1.2		nC
Q _{GS}	Gate to Source Charge of high side or low side HEMT	V _{DS} =50V, I _D = 16A		3.9		nC
Q _{OSS}	Output Charge (sum of high side HEMT, low side HEMT and gate-driver HV-Well charge)	V _{DS} =50V, I _D = 16A		90	115	nC
Q _{RR}	Source to Drain Reverse Recovery Charge	Not including internal driver bootstrap diode		0		nC
t _{HIPLH}	Propagation delay: HI Rising ⁽²⁾	LI=0V, VCC=5V, HB-HS=5V, VIN=48V		35	55	ns
t _{HIPL}	Propagation delay: HI Falling ⁽²⁾	LI=0V, VCC=5V, HB-HS=5V, VIN=48V		33	55	ns
t _{LPLH}	Propagation delay: LI Rising ⁽²⁾	HI=0V, VCC=5V, HB-HS=5V, VIN=48V		35	55	ns
t _{LPL}	Propagation delay: LI Falling ⁽²⁾	HI=0V, VCC=5V, HB-HS=5V, VIN=48V		33	55	ns
t _{MON}	Delay Matching: LI high & HI low ⁽²⁾			2	10	ns
t _{MOFF}	Delay Matching: LI low & HI high ⁽²⁾			2	10	ns

5.5 Electrical Characteristics (続き)

Unless otherwise noted, voltages are with respect to AGND; $-40^{\circ}\text{C} \leq T_J \leq 125^{\circ}\text{C}$ ⁽¹⁾

PARAMETER		TEST CONDITIONS	MIN	TYP	MAX	UNIT
t_{PW}	Minimum Input Pulse Width that Changes the Output			10		ns
INPUT PINS						
V_{IH}	High-Level Input Voltage Threshold	Rising Edge	1.87	2.06	2.22	V
V_{IL}	Low-Level Input Voltage Threshold	Falling Edge	1.48	1.66	1.76	V
V_{HYS}	Hysteresis between rising and falling threshold			400		mV
R_I	Input pull down resistance		100	200	300	k Ω
UNDER VOLTAGE PROTECTION						
V_{CCR}	VCC Rising edge threshold	Rising	3.2	3.8	4.5	V
V_{CCF}	VCC Falling edge threshold		3.0	3.6	4.3	V
$V_{CC(hyst)}$	VCC UVLO threshold hysteresis			210		mV
V_{HBR}	HB Rising edge threshold	Rising	2.5	3.2	3.9	V
V_{HBF}	HB Falling edge threshold		2.3	3.0	3.7	V
$V_{HB(hyst)}$	HB UVLO threshold hysteresis			210		mV
BOOTSTRAP DIODE						
V_{DL}	Low-Current forward voltage	$I_{HB-HS} = 100\mu\text{A}$		0.45	0.7	V
V_{DH}	High current forward voltage	$I_{HB-HS} = 100\text{mA}$		0.9	1.0	V
R_D	Dynamic Resistance	$I_{HB-HS} = 100\text{mA}$		1.85		Ω
	HB-HS Clamp	Regulation Voltage	4.65	5	5.2	V
t_{BS}	Bootstrap diode reverse recovery time	$I_F = 100\text{mA}$, $I_R = 100\text{mA}$		40		ns
Q_{RR}	Bootstrap diode reverse recovery charge	$V_{VIN} = 50\text{V}$		2		nC
SUPPLY CURRENTS						
I_{CC}	VCC Quiescent Current	$L_I = H_I = 0\text{V}$, $V_{CC} = 5\text{V}$		0.09	0.2	mA
I_{CC}	VCC Quiescent Current	$L_I = V_{CC} = 5\text{V}$, $H_I = 0\text{V}$		0.26	5	mA
I_{CCO}	Total VCC Operating Current	$f = 500\text{kHz}$, 50% Duty cycle, $V_{IN} = 48\text{V}$		12	15	mA
I_{HB}	HB Quiescent Current	$L_I = H_I = 0\text{V}$, $V_{CC} = 5\text{V}$, $H_B-H_S = 4.6\text{V}$		0.1	0.2	mA
I_{HB}	HB Quiescent Current	$L_I = 0\text{V}$, $H_I = V_{CC} = 5\text{V}$, $H_B-H_S = 4.6\text{V}$		0.16	4.5	mA
I_{HBO}	HB Operating Current	$f = 500\text{kHz}$, 50% Duty cycle, $V_{CC} = 5\text{V}$, $H_B-H_S = 4.6\text{V}$		5.6	8	mA

- (1) Parameters that show only a typical value are determined by design and may not be tested in production
(2) See *Propagation Delay and Mismatch Measurement* section

5.6 Typical Characteristics

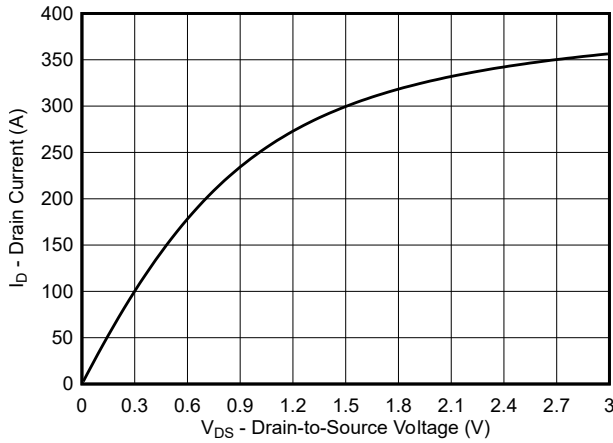

Figure 5-1. Typical Output Characteristics at 25°C

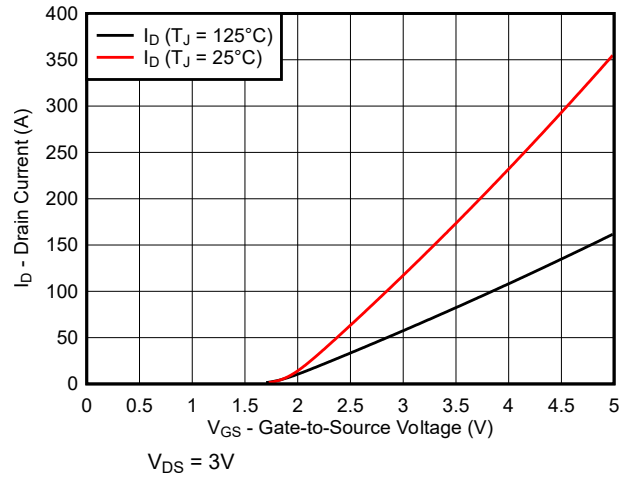

Figure 5-2. Typical Transfer Characteristics

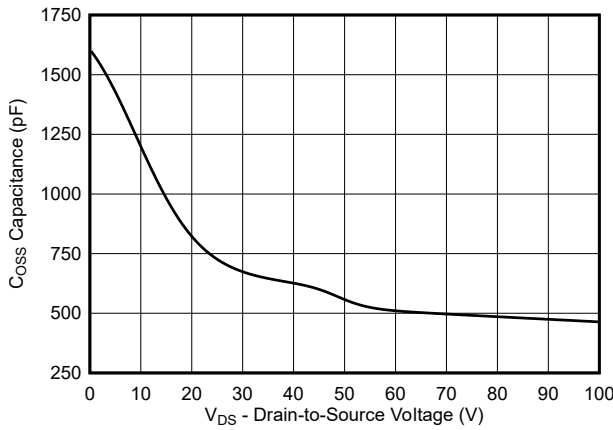

Figure 5-3. Typical Capacitance (Linear Scale)

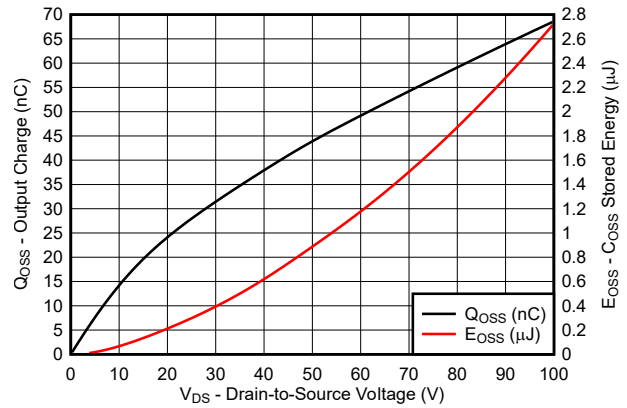

Figure 5-4. Typical Output Charge and C_{OSS} Stored Energy

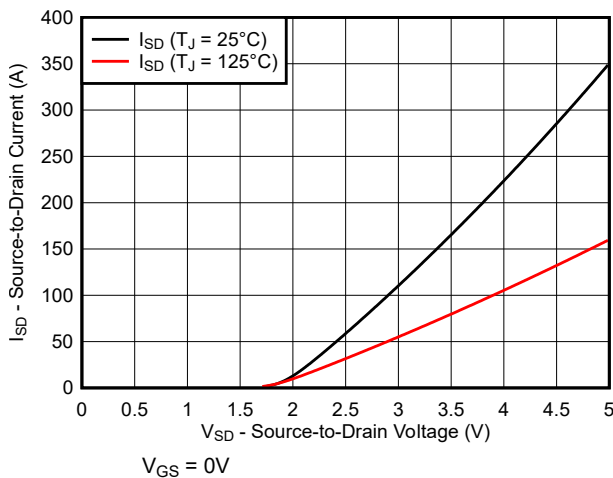

Figure 5-5. Reverse Drain-Source Characteristics

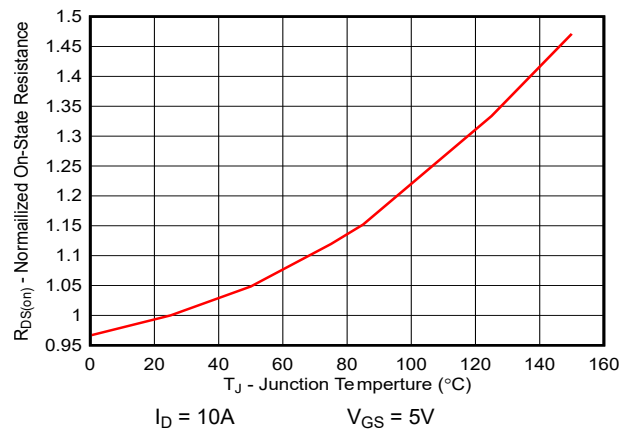
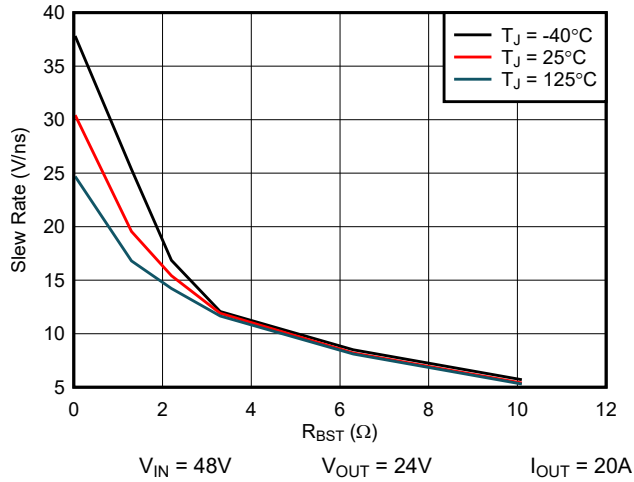
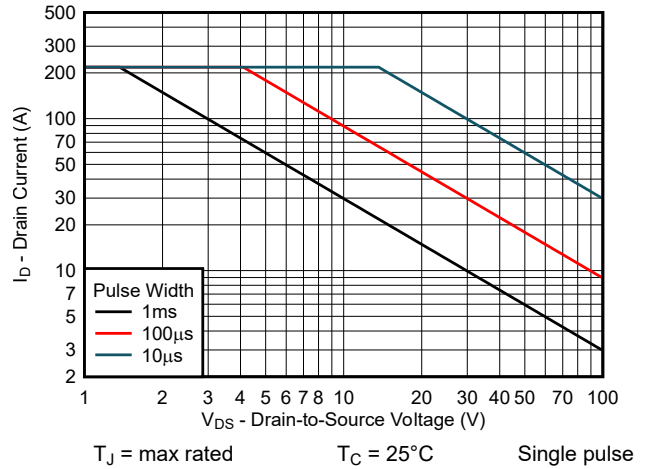

Figure 5-6. Normalized On-State Resistance vs Temperature



5-7. Slew Rate Control for a Buck Converter Using R_{BST}



5-8. Safe Operating Area

6 Parameter Measurement Information

6.1 Propagation Delay and Mismatch Measurement

Figure 6-1 shows the typical test setup used to measure the propagation mismatch. As the gate drives are not accessible, pullup and pulldown resistors in this test circuit are used to indicate when the low-side GaN FET turns ON and the high-side GaN FET turns OFF and vice versa to measure the t_{MON} and t_{MOFF} parameters. Resistance values used in this circuit for the pullup and pulldown resistors are in the order of $1k\Omega$; the current sources used are 2A.

Figure 6-2 through Figure 6-5 show propagation delay measurement waveforms. For turnon propagation delay measurements, the current sources are not used. For turnoff time measurements, the current sources are set to 2A, and a voltage clamp limit is also set, referred to as $V_{IN(CLAMP)}$. When measuring the high-side component turnoff delay, the current source across the high-side FET is turned on, the current source across the low-side FET is off, HI transitions from high-to-low, and output voltage transitions from V_{IN} to $V_{IN(CLAMP)}$. Similarly, for low-side component turnoff propagation delay measurements, the high-side component current source is turned off, and the low-side component current source is turned on, LI transitions from high to low and the output transitions from GND potential to $V_{IN(CLAMP)}$. The time between the transition of LI and the output change is the propagation delay time.

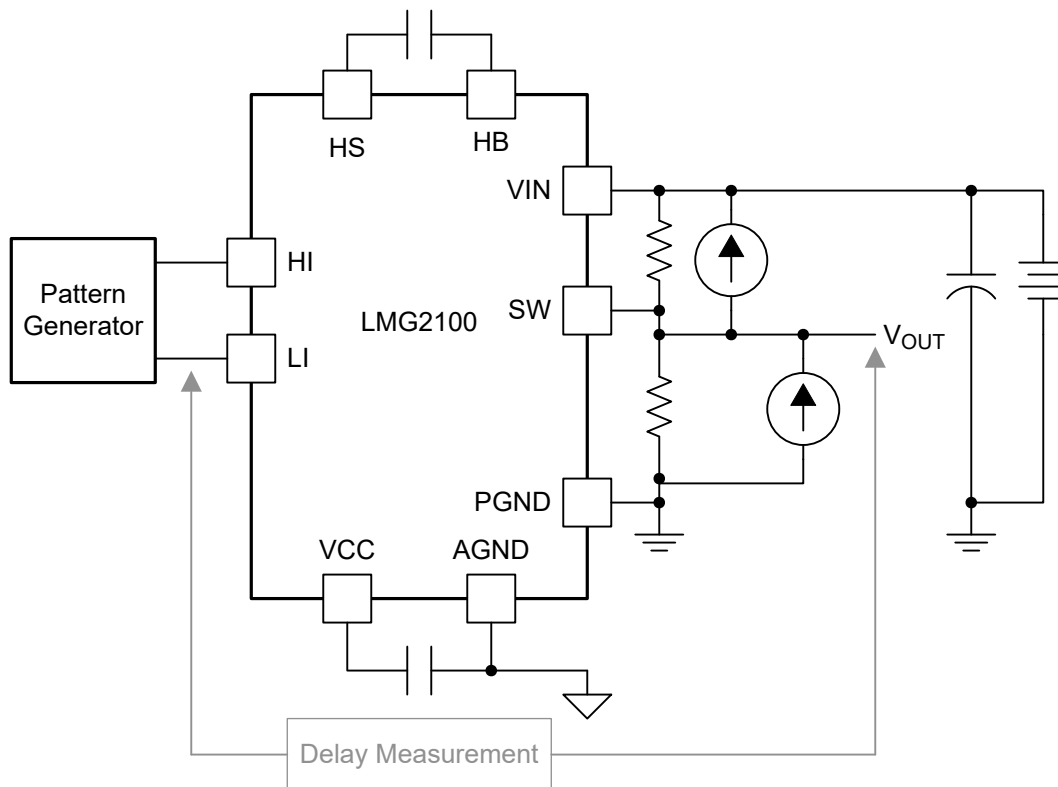
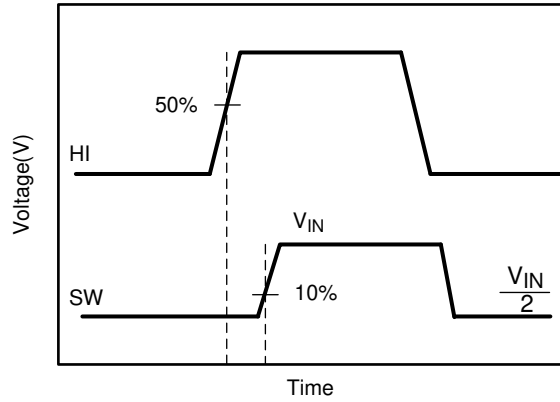
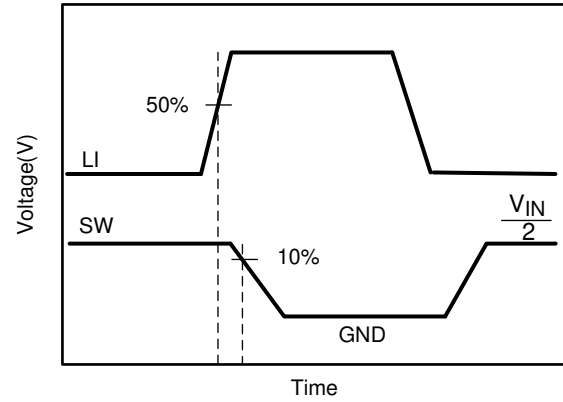

Figure 6-1. Propagation Delay and Propagation Mismatch Measurement



6-2. High-Side Gate Driver Turnon



6-3. Low-Side Gate Driver Turnon

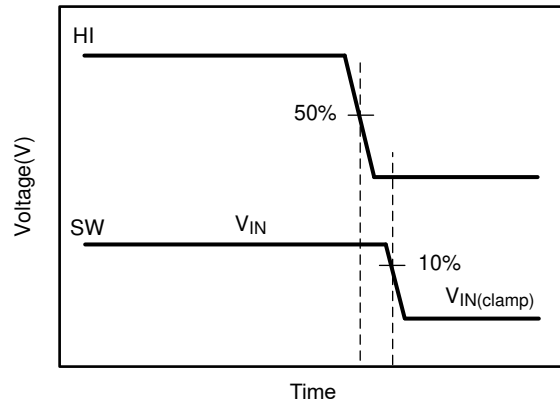

6-4. High-Side Gate Driver Turnoff

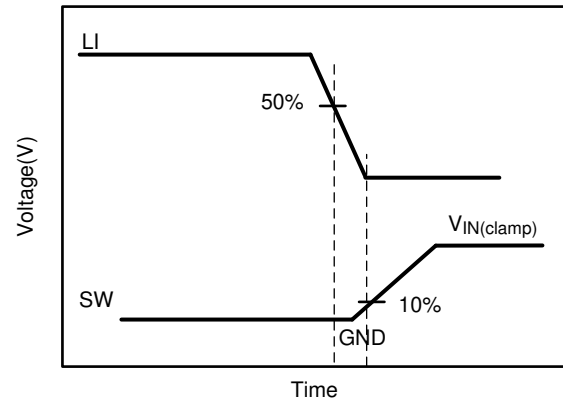

6-5. Low-Side Gate Driver Turnoff

7 Detailed Description

7.1 Overview

セクション 7.2 shows the LMG2100R026, half-bridge, GaN power stage with highly integrated high-side and low-side gate drivers, which includes built-in UVLO protection circuitry and an overvoltage clamp circuitry. The clamp circuitry limits the bootstrap refresh operation to ensure that the high-side gate driver overdrive does not exceed 5.4V. The device integrates two GaN FETs in a half-bridge configuration. The device can be used in many isolated and non-isolated topologies allowing very simple integration. The package is designed to minimize the loop inductance while keeping the PCB design simple. The drive strengths for turnon and turnoff are optimized to ensure high voltage slew rates without causing any excessive ringing on the gate or power loop.

7.2 Functional Block Diagram

The following image shows the functional block diagram of the LMG2100R026 device with integrated high-side and low-side GaN FETs.

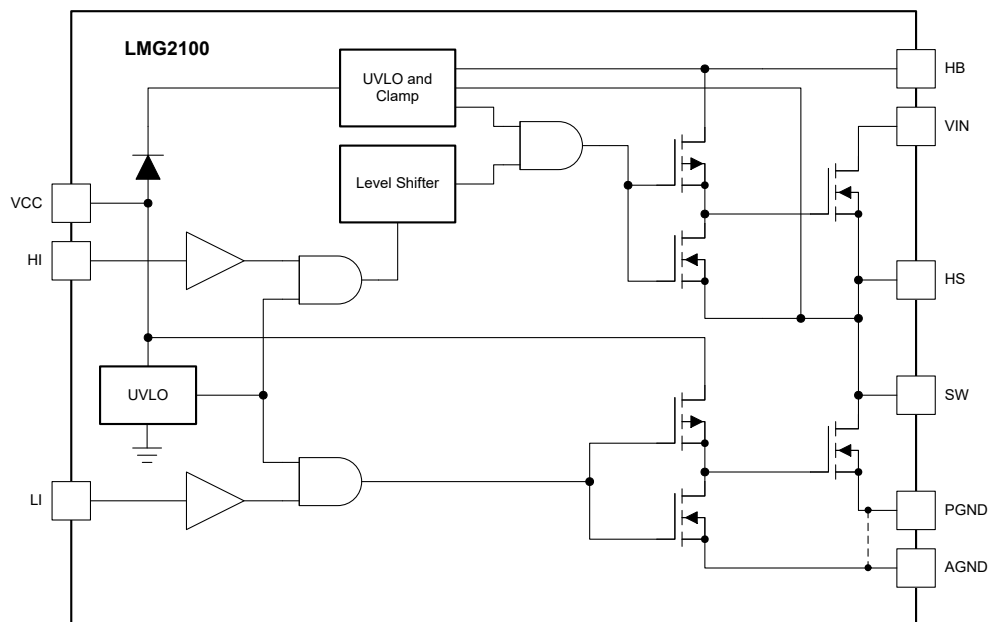

7.3 Feature Description

The LMG2100R026 device brings ease of designing high power density boards without the need for underfill while maintaining creepage and clearance requirements. The propagation delays between the high-side gate driver and low-side gate driver are matched to allow very tight control of dead time. Controlling the dead time is critical in GaN-based applications to maintain high efficiency. HI and LI can be independently controlled to minimize the third quadrant conduction of the low-side FET for hard switched buck converters. A very small propagation mismatch between the HI and LI to the drivers for both the falling and rising thresholds ensures dead times of < 10ns. Co-packaging the GaN FET half-bridge with the driver ensures minimized common source inductance. This minimized inductance has a significant performance impact on hard-switched topologies.

The built-in bootstrap circuit with clamp prevents the high-side gate drive from exceeding the GaN FETs maximum gate-to-source voltage (V_{gs}) without any additional external circuitry. The built-in driver has an undervoltage lockout (UVLO) on the VCC and bootstrap (HB-HS) rails. When the voltage is below the UVLO threshold voltage, the device ignores both the HI and LI signals to prevent the GaN FETs from being partially turned on. Below UVLO, if there is sufficient voltage ($V_{VCC} > 2.5V$), the driver actively pulls the high-side and low-side gate driver output low. The UVLO threshold hysteresis of 200mV prevents chattering and unwanted turnon due to voltage spikes. Use an external VCC bypass capacitor with a value of 0.1 μ F or higher. TI recommends a size of 0402 to minimize trace length to the pin. Place the bypass and bootstrap capacitors as close as possible to the device to minimize parasitic inductance.

7.3.1 Control Inputs

The LMG2100R026 inputs pins are independently controlled with TTL input thresholds and can support 3.3V and 5V logic levels regardless of the VCC voltage.

In order to allow flexibility to optimize deadtime according to design needs, the LMG2100R026 does not implement an overlap protection functionality. If both HI and LI are asserted, both the high-side and low-side GaN FETs are turned on. Careful consideration must be applied to the control inputs in order to avoid a shoot-through condition.

7.3.2 Start-Up and UVLO

The LMG2100R026 has an UVLO on both the VCC and HB (bootstrap) supplies. When the VCC voltage is below the threshold voltage of 3.8V, both the HI and LI inputs are ignored, to prevent the GaN FETs from being partially turned on. Also, if there is insufficient VCC voltage, the UVLO actively pulls the high- and low-side GaN FET gates low. When the HB to HS bootstrap voltage is below the UVLO threshold of 3.2V, only the high-side GaN FET gate is pulled low. Both UVLO threshold voltages have 200mV of hysteresis to avoid chattering.

表 7-1. V_{CC} UVLO Feature Logic Operation

CONDITION ($V_{HB} - V_{HS} > V_{HBR}$)	HI	LI	SW
$V_{CC} - V_{AGND} < V_{CCR}$ during device start-up	H	L	Hi-Z
$V_{CC} - V_{AGND} < V_{CCR}$ during device start-up	L	H	Hi-Z
$V_{CC} - V_{AGND} < V_{CCR}$ during device start-up	H	H	Hi-Z
$V_{CC} - V_{AGND} < V_{CCR}$ during device start-up	L	L	Hi-Z
$V_{CC} - V_{AGND} < V_{CCF}$ after device start-up	H	L	Hi-Z
$V_{CC} - V_{AGND} < V_{CCF}$ after device start-up	L	H	Hi-Z
$V_{CC} - V_{AGND} < V_{CCF}$ after device start-up	H	H	Hi-Z
$V_{CC} - V_{AGND} < V_{CCF}$ after device start-up	L	L	Hi-Z

表 7-2. V_{HB-HS} UVLO Feature Logic Operation

CONDITION ($V_{CC} > V_{CCR}$)	HI	LI	SW
$V_{HB} - V_{HS} < V_{HBR}$ during device start-up	H	L	Hi-Z
$V_{HB} - V_{HS} < V_{HBR}$ during device start-up	L	H	PGND
$V_{HB} - V_{HS} < V_{HBR}$ during device start-up	H	H	PGND
$V_{HB} - V_{HS} < V_{HBR}$ during device start-up	L	L	Hi-Z

表 7-2. V_{HB-HS} UVLO Feature Logic Operation (続き)

CONDITION ($V_{CC} > V_{CCR}$)	HI	LI	SW
$V_{HB} - V_{HS} < V_{HBF}$ after device start-up	H	L	Hi-Z
$V_{HB} - V_{HS} < V_{HBF}$ after device start-up	L	H	PGND
$V_{HB} - V_{HS} < V_{HBF}$ after device start-up	H	H	PGND
$V_{HB} - V_{HS} < V_{HBF}$ after device start-up	L	L	Hi-Z

7.3.3 Bootstrap Supply Voltage Clamping

The high-side bias voltage is generated using a bootstrap technique and is internally clamped at 5V (typical). This clamp prevents the gate voltage from exceeding the maximum gate-source voltage rating of the enhancement-mode GaN FETs.

7.3.4 Level Shift

The level-shift circuit is the interface from the high-side input HI to the high-side driver stage, which is referenced to the switch node (HS). The level shift allows control of the high-side GaN FET gate driver output, which is referenced to the HS pin and provides excellent delay matching with the low-side driver.

7.4 Device Functional Modes

The LMG2100R026 operates in normal mode and UVLO mode. See [セクション 7.3.2](#) for information on UVLO operation mode. In the normal mode, the output state is dependent on the states of the HI and LI pins. [表 7-3](#) lists the output states for different input pin combinations. Note that when both HI and LI are asserted, both GaN FETs in the power stage are turned on. Careful consideration must be applied to the control inputs in order to avoid this state, as it will result in a shoot-through condition, which can permanently damage the device.

表 7-3. Truth Table

HI	LI	HIGH-SIDE GaN FET	LOW-SIDE GaN FET	SW
L	L	OFF	OFF	Hi-Z
L	H	OFF	ON	PGND
H	L	ON	OFF	VIN
H	H	ON	ON	---

8 Application and Implementation

注

Information in the following applications sections is not part of the TI component specification, and TI does not warrant its accuracy or completeness. TI's customers are responsible for determining suitability of components for their purposes. Customers should validate and test their design implementation to confirm system functionality.

8.1 Application Information

The LMG2100R026 GaN power stage is a versatile building block for various types of high-frequency, switch-mode power applications. The high-performance gate driver IC integrated in the package helps minimize the parasitics and results in extremely fast switching of the GaN FETs. The device design is highly optimized for synchronous buck converters and other half-bridge configurations.

8.2 Typical Application

 [8-1](#) shows a synchronous buck converter application with VCC connected to a 5V supply. It is critical to optimize the power loop (loop impedance from VIN capacitor to PGND). Having a high power loop inductance causes significant ringing in the SW node and also causes the associated power loss. The LMG2100R026 has VIN and PGND pins next to each other. This enables the VIN capacitor to be placed very close to LMG2100R026 on the top layer of the PCB, minimizing power loop inductance.



図 8-1. Typical Connection Diagram For a Synchronous Buck Converter

8.2.1 Design Requirements

When designing a synchronous buck converter application that incorporates the LMG2100R026 power stage, some design considerations must be evaluated first to make the most appropriate selection. Among these considerations are the input voltages, passive components, operating frequency, and controller selection. 表 8-1 shows some sample values for a typical application. See セクション 8.3, セクション 8.4, and セクション 8.2.2.4 for other key design considerations for the LMG2100R026.

表 8-1. Design Parameters

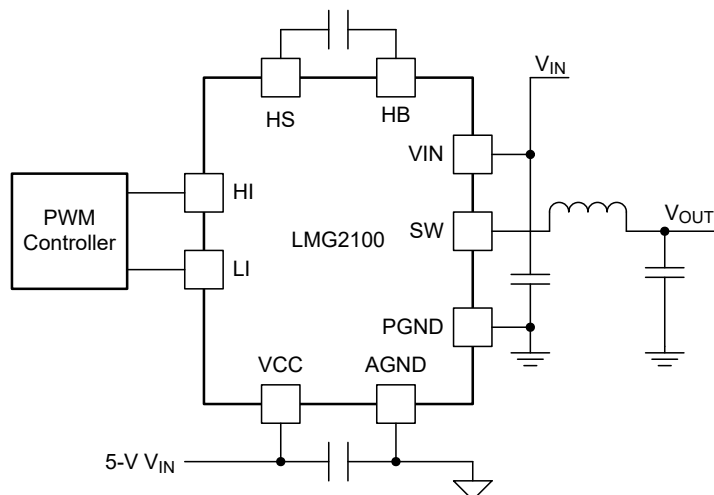
PARAMETER	SAMPLE VALUE
Half-bridge input supply voltage, V_{IN}	48V
Output voltage, V_{OUT}	12V
Output current	8A
$V_{HB} - V_{HS}$ bootstrap capacitor	0.1 μ F, X5R
Switching frequency	1MHz
Dead time	8ns
Inductor	4.7 μ H
Controller	LM5148

8.2.2 Detailed Design Procedure

This procedure outlines the design considerations of LMG2100R026 in a synchronous buck converter. For additional design help, see セクション 9.1.1.

8.2.2.1 V_{CC} Bypass Capacitor

The V_{CC} bypass capacitor provides the gate charge for the low-side and high-side transistors and absorbs the reverse recovery charge of the bootstrap diode. The required bypass capacitance can be calculated with 式 1.

$$C_{VCC} = (2 \times Q_G + Q_{RR}) / \Delta V \quad (1)$$

Q_G is the individual and equal gate charge of the high-side and low-side GaN FETs. Q_{RR} is the reverse recovery charge of the bootstrap diode. ΔV is the maximum allowable voltage drop across the bypass capacitor. A 0.1- μ F or larger value, good-quality, ceramic capacitor is recommended. Place the bypass capacitor as close as possible to the V_{CC} and $AGND$ pins of the device to minimize the parasitic inductance.

8.2.2.2 Bootstrap Capacitor

The bootstrap capacitor provides the gate charge for the high-side gate drive, dc bias power for HB UVLO circuit, and the reverse recovery charge of the bootstrap diode. The required bypass capacitance can be calculated using 式 2.

$$C_{BST} = (Q_G + Q_{RR} + I_{HB} \times t_{ON(max)}) / \Delta V \quad (2)$$

where

- I_{HB} is the quiescent current of the high-side gate driver
- $t_{ON(max)}$ is the maximum on-time period of the high-side gate driver
- Q_{RR} is the reverse recovery charge of the bootstrap diode
- Q_G is the gate charge of the high-side GaN FET
- ΔV is the permissible ripple in the bootstrap capacitor ($< 100\text{mV}$, typical)

A $0.1\mu\text{F}$, 16V, 0402 ceramic capacitor is suitable for most applications. Place the bootstrap capacitor as close as possible to the HB and HS pins.

8.2.2.3 Slew Rate Control

Figure 8-2 shows a switching application where the slew rate on the switch node may be controlled by using resistors R_{VCC} and R_{BST} . R_{VCC} may be used to slow down the turn-on of the Low Side GaN FET (for example, in a boost converter), and R_{BST} may be used to slow down the turn-on of the High Side GaN FET (for example, in a buck converter). Using these resistors allows the system engineer to optimize the tradeoff between higher efficiency (faster slew rates) and lower ringing (slower slew rates).

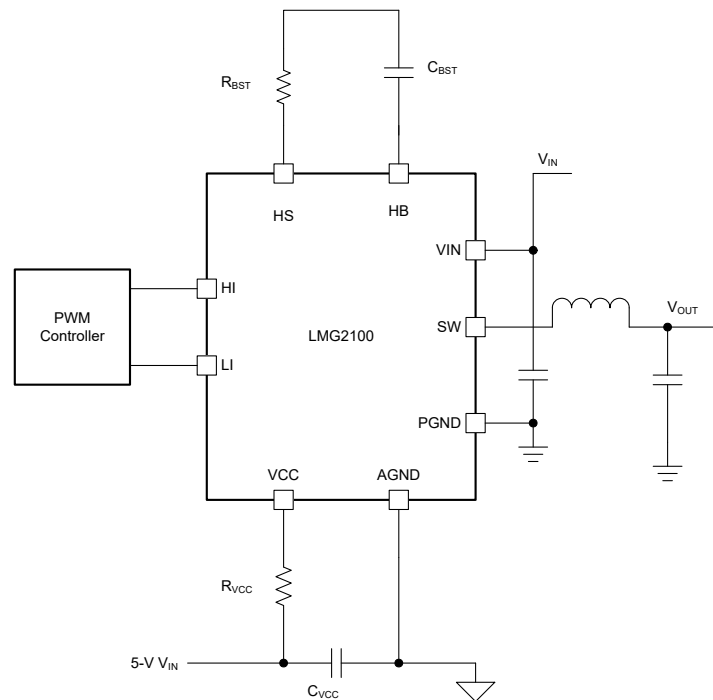

Figure 8-2. Slew Rate Control with R_{BST} and R_{VCC} Resistors

8.2.2.4 Power Dissipation

Ensure that the power loss in the driver and the GaN FETs is maintained below the maximum power dissipation limit of the package at the operating temperature. The smaller the power loss in the driver and the GaN FETs, the higher the maximum operating frequency that can be achieved in the application. The total power dissipation of the LMG2100R026 device is the sum of the gate driver losses, the bootstrap diode power loss and the switching and conduction losses in the FETs.

The gate driver losses are incurred by charge and discharge of the capacitive load. It can be approximated using 式 3.

$$P = 2 \times Q_G \times V_{CC} \times f_{SW} \quad (3)$$

where

- Q_G is the gate charge
- V_{CC} is the bias supply
- f_{SW} is the switching frequency

There are some additional losses in the gate drivers due to the internal CMOS stages used to buffer the outputs.

The bootstrap diode power loss is the sum of the forward bias power loss that occurs while charging the bootstrap capacitor and the reverse bias power loss that occurs during reverse recovery. Because each of these events happens once per cycle, the diode power loss is proportional to the operating frequency. Higher input voltages (V_{IN}) to the half bridge also result in higher reverse recovery losses.

The power losses due to the GaN FETs can be divided into conduction losses and switching losses. Conduction losses are resistive losses and can be calculated using 式 4.

$$P_{COND} = \left[(I_{RMS(HS)})^2 \times R_{DS(on)HS} \right] + \left[(I_{RMS(LS)})^2 \times R_{DS(on)LS} \right] \quad (4)$$

where

- $R_{DS(on)HS}$ is the high-side GaN FET on-resistance
- $R_{DS(on)LS}$ is the low-side GaN FET on-resistance
- $I_{RMS(HS)}$ is the high-side GaN FET RMS current
- $I_{RMS(LS)}$ and low-side GaN FET RMS current

The switching losses can be computed to a first order using 式 5, where t_{TR} can be approximated by dividing V_{IN} by 25V/ns, which is a conservative estimate of the switched node slew rate.

$$P_{SW} = V_{IN} \times I_{OUT} \times t_{TR} \times f_{SW} + V_{IN} \times V_{IN} \times C_{OSS(ER)} \times f_{SW} \quad (5)$$

where

- t_{TR} is sum of the switch node transition times from ON to OFF and from OFF to ON
- $C_{OSS(ER)}$ is the output capacitance of each GaN FET

Note that the low-side FET does not suffer from this loss. The third quadrant loss in the low-side device is ignored in this first order loss calculation.

As described previously, switching frequency has a direct effect on device power dissipation. Although the gate driver of the LMG2100R026 device is capable of driving the GaN FETs at frequencies up to 10MHz, careful consideration must be applied to ensure that the running conditions for the device meet the recommended operating temperature specification. Specifically, hard-switched topologies tend to generate more losses and self-heating than soft-switched applications.

The sum of the driver loss, the bootstrap diode loss, and the switching and conduction losses in the GaN FETs is the total power loss of the device. Careful board layout with an adequate amount of thermal vias close to the

power pads (VIN and PGND) allows optimum power dissipation from the package. A top-side mounted heat sink with airflow can also improve the package power dissipation.

8.2.3 Application Curves

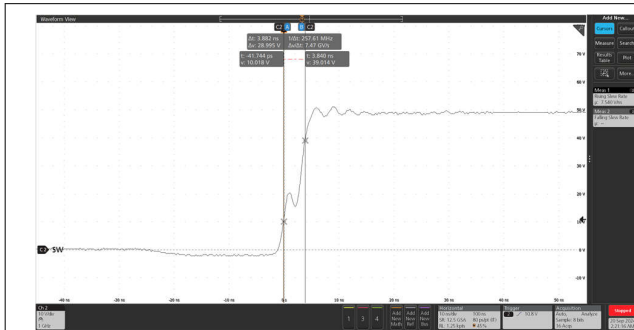

8-3. SW Node Behavior Showing the Dead Time and Rise Time for a Buck Converter with $R_{BST}=1.3 \Omega$

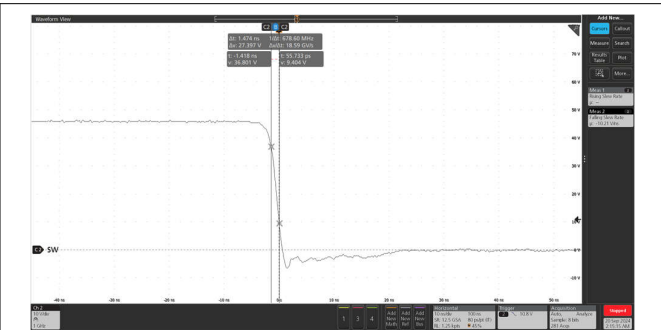

8-4. SW Node Behavior Showing the Fall Time for a Buck Converter

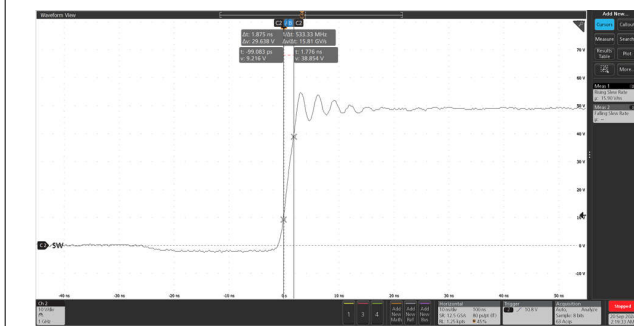

8-5. SW Node Behavior Showing the Rise Time for a Buck Converter with HB-HS supplied externally and $R_{BST}=1.3 \Omega$

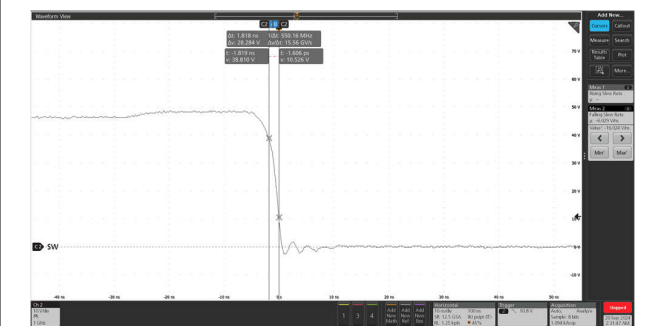

8-6. SW Node Behavior Showing the Fall Time for a Boost Converter $R_{VCC}=1.3 \Omega$

8.3 Power Supply Recommendations

The recommended bias supply voltage range for LMG2100R026 is from 4.75V to 5.25V. Note that the gate voltage of the low-side GaN FET is not clamped internally. Hence, it is important to keep the VCC bias supply within the recommended operating range to prevent exceeding the low-side GaN transistor gate breakdown voltage.

The UVLO protection feature also involves a hysteresis function. This means that once the device is operating in normal mode, if the VCC voltage drops, the device continues to operate in normal mode as far as the voltage drop does not exceeds the hysteresis specification, $V_{CC(hyst)}$. If the voltage drop is more than hysteresis specification, the device shuts down. Therefore, while operating at or near the 4.5V range, the voltage ripple on the auxiliary power supply output must be smaller than the hysteresis specification of LMG2100R026 to avoid triggering device-shutdown.

Place a local bypass capacitor between the VCC and AGND pins. This capacitor must be located as close as possible to the device. A low ESR, ceramic surface-mount capacitor is recommended. TI recommends using two capacitors across VCC and AGND: a 100nF ceramic surface-mount capacitor for high frequency filtering placed very close to VCC and AGND pin, and another surface-mount capacitor, 220nF to 10μF, for IC bias requirements.

8.4 Layout

8.4.1 Layout Guidelines

To maximize the efficiency benefits of fast switching, it is extremely important to optimize the board layout such that the power loop impedance is minimal. When using a multilayer board (more than 2 layers), power loop parasitic impedance is minimized by having the return path to the input capacitor (between VIN and PGND), small and directly underneath the first layer as shown in [Figure 8-7](#) and [Figure 8-8](#). Loop inductance is reduced due to flux cancellation as the return current is directly underneath and flowing in the opposite direction.

Insufficient attention to the above power loop layout guidelines can result in excessive overshoot and undershoot on the switch node.

It is also critical that the VCC capacitors and the bootstrap capacitors are as close as possible to the device and in the first layer. Carefully consider the AGND connection of LMG2100R026 device. It must NOT be directly connected to PGND so that PGND noise does not directly shift AGND and cause spurious switching events due to noise injected in HI and LI signals.

Refer [LMG2100 EVM](#) for an actual layout based on these recommendations.

8.4.2 Layout Examples

Placements shown in [Figure 8-7](#) and in the cross section of [Figure 8-8](#) show the suggested placement of the device with respect to sensitive passive components, such as VIN, bootstrap capacitors (HS and HB) and VSS capacitors. Use appropriate spacing in the layout to reduce creepage and maintain clearance requirements in accordance with the application pollution level. Inner layers if present can be more closely spaced due to negligible pollution.

The layout must be designed to minimize the capacitance at the SW node. Use as small an area of copper as possible to connect the device SW pin to the inductor, or transformer, or other output load. Furthermore, ensure that the ground plane or any other copper plane has a cutout so that there is no overlap with the SW node, as this would effectively form a capacitor on the printed circuit board. Additional capacitance on this node reduces the advantages of the advanced packaging approach of the LMG2100R026 and may result in reduced performance.

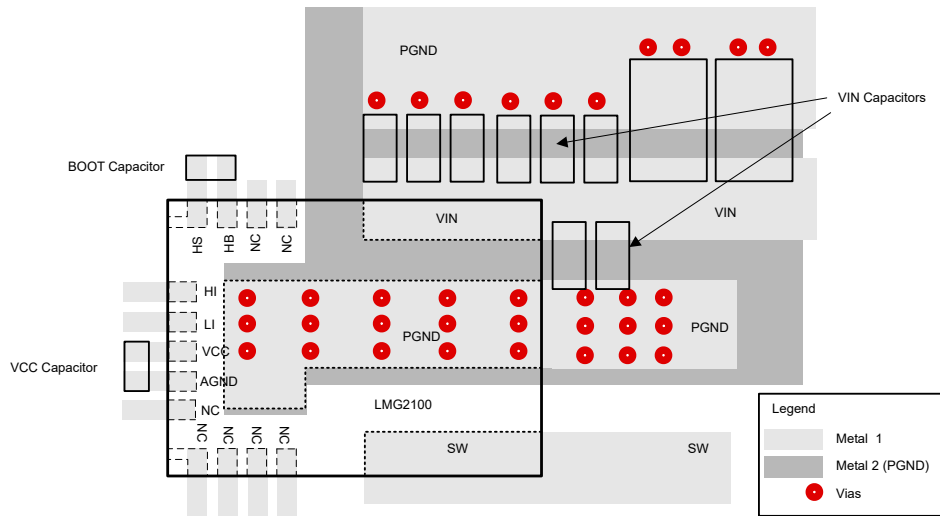
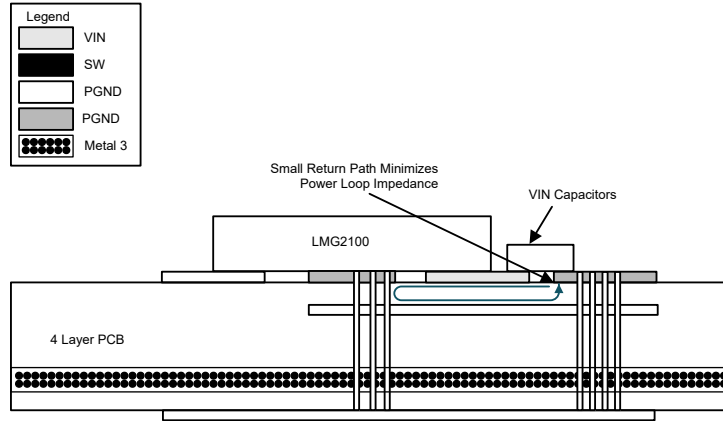
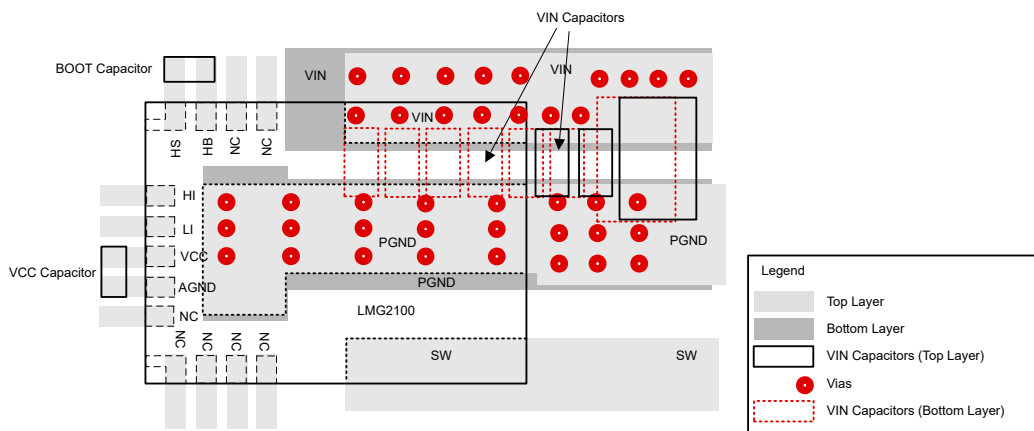

Figure 8-7. External Component Placement (Multi-layer PCB)



8-8. Four-Layer Board Cross Section With Return Path Directly Underneath for Power Loop



8-9. External Component Placement (Double Layer PCB)

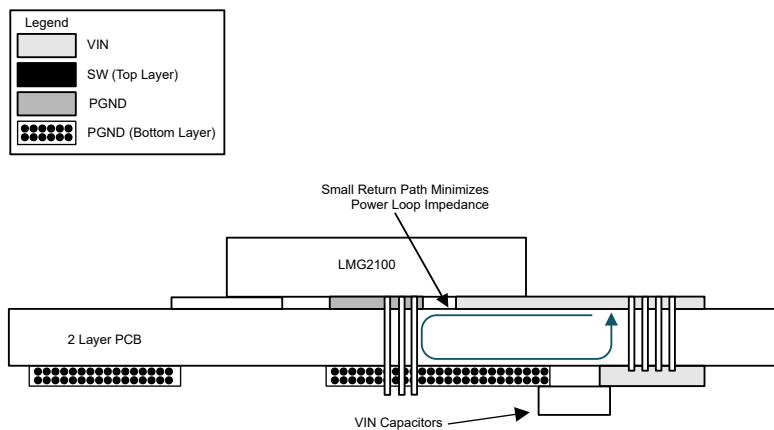

8-10. Two-Layer Board Cross Section With Return Path

Two-layer boards are not recommended for use with LMG2100R026 device due to the larger power loop inductance. However, if design considerations allow only two board layers, place the input decoupling capacitors immediately behind the device on the back-side of the board to minimize loop inductance. 8-9 and 8-10 show a layout example for two-layer boards.

9 Device and Documentation Support

9.1 Documentation Support

9.1.1 Related Documentation

[Layout Guidelines for LMG2100R044 GaN Power Stage Module](#)

[Using the LMG2100R044: GaN Half-Bridge Power Module Evaluation Module](#)

9.2 Receiving Notification of Documentation Updates

To receive notification of documentation updates, navigate to the device product folder on ti.com. In the upper right corner, click on *Alert me* to register and receive a weekly digest of any product information that has changed. For change details, review the revision history included in any revised document.

9.3 サポート・リソース

テキサス・インスツルメンツ E2E™ サポート・フォーラムは、エンジニアが検証済みの回答と設計に関するヒントをエキスパートから迅速かつ直接得ることができる場所です。既存の回答を検索したり、独自の質問をしたりすることで、設計に必要な支援を迅速に得ることができます。

リンクされているコンテンツは、各寄稿者により「現状のまま」提供されるものです。これらはテキサス・インスツルメンツの仕様を構成するものではなく、必ずしもテキサス・インスツルメンツの見解を反映したものではありません。テキサス・インスツルメンツの[使用条件](#)を参照してください。

9.4 Trademarks

テキサス・インスツルメンツ E2E™ is a trademark of Texas Instruments.

すべての商標は、それぞれの所有者に帰属します。

9.5 静電気放電に関する注意事項



この IC は、ESD によって破損する可能性があります。テキサス・インスツルメンツは、IC を取り扱う際には常に適切な注意を払うことを推奨します。正しい取り扱いおよび設置手順に従わない場合、デバイスを破損するおそれがあります。

ESD による破損は、わずかな性能低下からデバイスの完全な故障まで多岐にわたります。精密な IC の場合、パラメータがわずかに変化するだけで公表されている仕様から外れる可能性があるため、破損が発生しやすくなっています。

9.6 用語集

[テキサス・インスツルメンツ用語集](#) この用語集には、用語や略語の一覧および定義が記載されています。

10 Revision History

資料番号末尾の英字は改訂を表しています。その改訂履歴は英語版に準じています。

Changes from Revision * (July 2024) to Revision A (October 2024)	Page
• ドキュメントのステータスを「事前情報」から「量産データ」	1

11 Mechanical, Packaging, and Orderable Information

The following pages include mechanical, packaging, and orderable information. This information is the most current data available for the designated devices. This data is subject to change without notice and revision of this document. For browser-based versions of this data sheet, refer to the left-hand navigation.

11.1 Package Information

The LMG2100R026 device package is rated as an MSL2 package (Moisture Sensitivity Level 2). Refer to application report [AN-2029 Handling and Process Recommendations](#) for specific handling and process recommendations of an MSL2 package.

PACKAGING INFORMATION

Orderable Device	Status (1)	Package Type	Package Drawing	Pins	Package Qty	Eco Plan (2)	Lead finish/ Ball material (6)	MSL Peak Temp (3)	Op Temp (°C)	Device Marking (4/5)	Samples
LMG2100R026VBNR	ACTIVE	VQFN-FCRLF	VBN	18	2500	RoHS & Green	NIPDAU	Level-2-260C-1 YEAR		R026	Samples
XLMG2100R026VBNR	ACTIVE	VQFN-FCRLF	VBN	16	2500	TBD	Call TI	Call TI	-40 to 125		Samples

(1) The marketing status values are defined as follows:

ACTIVE: Product device recommended for new designs.

LIFEBUY: TI has announced that the device will be discontinued, and a lifetime-buy period is in effect.

NRND: Not recommended for new designs. Device is in production to support existing customers, but TI does not recommend using this part in a new design.

PREVIEW: Device has been announced but is not in production. Samples may or may not be available.

OBSOLETE: TI has discontinued the production of the device.

(2) **RoHS:** TI defines "RoHS" to mean semiconductor products that are compliant with the current EU RoHS requirements for all 10 RoHS substances, including the requirement that RoHS substance do not exceed 0.1% by weight in homogeneous materials. Where designed to be soldered at high temperatures, "RoHS" products are suitable for use in specified lead-free processes. TI may reference these types of products as "Pb-Free".

RoHS Exempt: TI defines "RoHS Exempt" to mean products that contain lead but are compliant with EU RoHS pursuant to a specific EU RoHS exemption.

Green: TI defines "Green" to mean the content of Chlorine (Cl) and Bromine (Br) based flame retardants meet JS709B low halogen requirements of <=1000ppm threshold. Antimony trioxide based flame retardants must also meet the <=1000ppm threshold requirement.

(3) MSL, Peak Temp. - The Moisture Sensitivity Level rating according to the JEDEC industry standard classifications, and peak solder temperature.

(4) There may be additional marking, which relates to the logo, the lot trace code information, or the environmental category on the device.

(5) Multiple Device Markings will be inside parentheses. Only one Device Marking contained in parentheses and separated by a "~" will appear on a device. If a line is indented then it is a continuation of the previous line and the two combined represent the entire Device Marking for that device.

(6) Lead finish/Ball material - Orderable Devices may have multiple material finish options. Finish options are separated by a vertical ruled line. Lead finish/Ball material values may wrap to two lines if the finish value exceeds the maximum column width.

Important Information and Disclaimer:The information provided on this page represents TI's knowledge and belief as of the date that it is provided. TI bases its knowledge and belief on information provided by third parties, and makes no representation or warranty as to the accuracy of such information. Efforts are underway to better integrate information from third parties. TI has taken and continues to take reasonable steps to provide representative and accurate information but may not have conducted destructive testing or chemical analysis on incoming materials and chemicals. TI and TI suppliers consider certain information to be proprietary, and thus CAS numbers and other limited information may not be available for release.

In no event shall TI's liability arising out of such information exceed the total purchase price of the TI part(s) at issue in this document sold by TI to Customer on an annual basis.

TAPE AND REEL INFORMATION



QUADRANT ASSIGNMENTS FOR PIN 1 ORIENTATION IN TAPE



*All dimensions are nominal

Device	Package Type	Package Drawing	Pins	SPQ	Reel Diameter (mm)	Reel Width W1 (mm)	A0 (mm)	B0 (mm)	K0 (mm)	P1 (mm)	W (mm)	Pin1 Quadrant
LMG2100R026VBNR	VQFN-FCRLF	VBN	18	2500	330.0	16.4	5.3	7.8	1.2	8.0	16.0	Q1

TAPE AND REEL BOX DIMENSIONS

*All dimensions are nominal

Device	Package Type	Package Drawing	Pins	SPQ	Length (mm)	Width (mm)	Height (mm)
LMG2100R026VBNR	VQFN-FCRLF	VBN	18	2500	367.0	367.0	38.0

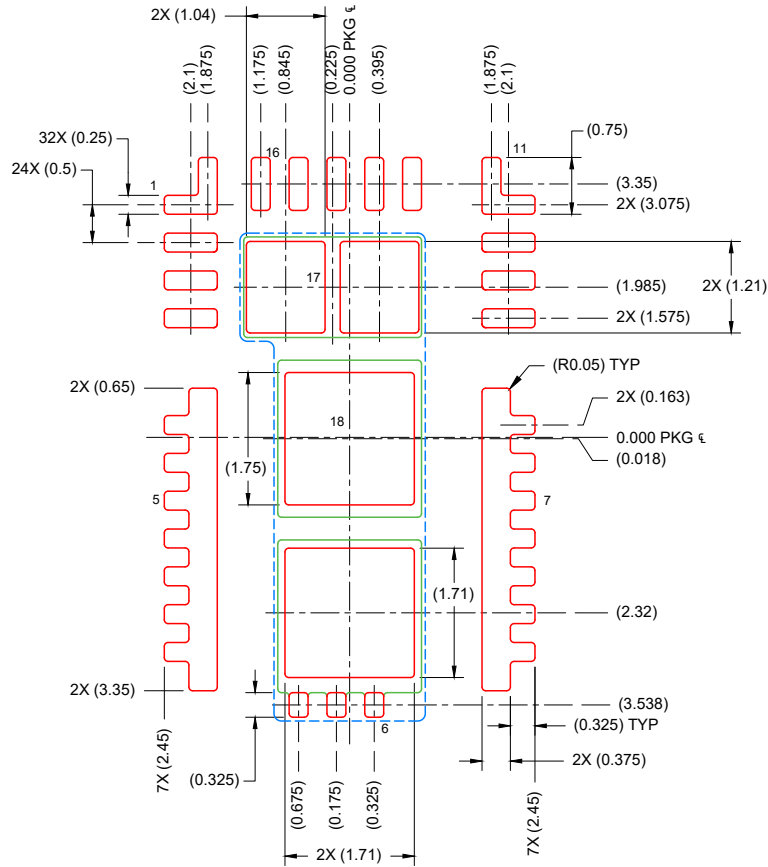

SOLDER PASTE EXAMPLE
 BASED ON 0.1 mm THICK STENCIL
 SCALE: 10X

PRINTED SOLDER COVERAGE BY AREA UNDER PACKAGE
 PAD 6: 78%
 PAD 17: 81%
 PAD 18: 76%

4230281/C 03/2024

NOTES: (continued)

5. Laser cutting apertures with trapezoidal walls and rounded corners may offer better paste release. IPC-7525 may have alternate design recommendations.

重要なお知らせと免責事項

テキサス・インスツルメンツは、技術データと信頼性データ(データシートを含みます)、設計リソース(リファレンス デザインを含みます)、アプリケーションや設計に関する各種アドバイス、Web ツール、安全性情報、その他のリソースを、欠陥が存在する可能性のある「現状のまま」提供しており、商品性および特定目的に対する適合性の黙示保証、第三者の知的財産権の非侵害保証を含むいかなる保証も、明示的または黙示的にかかわらず拒否します。

これらのリソースは、テキサス・インスツルメンツ製品を使用する設計の経験を積んだ開発者への提供を意図したものです。(1) お客様のアプリケーションに適したテキサス・インスツルメンツ製品の選定、(2) お客様のアプリケーションの設計、検証、試験、(3) お客様のアプリケーションに該当する各種規格や、その他のあらゆる安全性、セキュリティ、規制、または他の要件への確実な適合に関する責任を、お客様のみが単独で負うものとします。

上記の各種リソースは、予告なく変更される可能性があります。これらのリソースは、リソースで説明されているテキサス・インスツルメンツ製品を使用するアプリケーションの開発の目的でのみ、テキサス・インスツルメンツはその使用をお客様に許諾します。これらのリソースに関して、他の目的で複製することや掲載することは禁止されています。テキサス・インスツルメンツや第三者の知的財産権のライセンスが付与されている訳ではありません。お客様は、これらのリソースを自身で使用した結果発生するあらゆる申し立て、損害、費用、損失、責任について、テキサス・インスツルメンツおよびその代理人を完全に補償するものとし、テキサス・インスツルメンツは一切の責任を拒否します。

テキサス・インスツルメンツの製品は、[テキサス・インスツルメンツの販売条件](#)、または [ti.com](https://www.ti.com) やかかるテキサス・インスツルメンツ製品の関連資料などのいずれかを通じて提供する適用可能な条項の下で提供されています。テキサス・インスツルメンツがこれらのリソースを提供することは、適用されるテキサス・インスツルメンツの保証または他の保証の放棄の拡大や変更を意味するものではありません。

お客様がいかなる追加条項または代替条項を提案した場合でも、テキサス・インスツルメンツはそれらに異議を唱え、拒否します。

郵送先住所：Texas Instruments, Post Office Box 655303, Dallas, Texas 75265
Copyright © 2025, Texas Instruments Incorporated