



## Table of Contents

<b>1 特長</b> .....	<b>1</b>	<b>7 Application and Implementation</b> .....	<b>31</b>
<b>2 アプリケーション</b> .....	<b>1</b>	7.1 Application Information.....	31
<b>3 概要</b> .....	<b>1</b>	7.2 Typical Applications.....	33
<b>4 Pin Configuration and Functions</b> .....	<b>3</b>	7.3 Layout.....	36
<b>5 Specifications</b> .....	<b>7</b>	7.4 Power Supply Recommendations.....	37
5.1 Absolute Maximum Ratings.....	7	7.5 Register Map.....	40
5.2 ESD Ratings.....	7	<b>8 Device and Documentation Support</b> .....	<b>58</b>
5.3 Recommended Operating Conditions.....	7	8.1 Device Support.....	58
5.4 Thermal Information.....	7	8.2 Documentation Support.....	58
5.5 Electrical Characteristics.....	8	8.3 ドキュメントの更新通知を受け取る方法.....	58
5.6 Timing Requirements.....	10	8.4 サポート・リソース.....	58
5.7 Timing Diagram.....	10	8.5 Trademarks.....	58
5.8 Typical Characteristics.....	11	8.6 静電気放電に関する注意事項.....	58
<b>6 Detailed Description</b> .....	<b>14</b>	8.7 用語集.....	59
6.1 Overview.....	14	<b>9 Revision History</b> .....	<b>59</b>
6.2 Functional Block Diagram.....	15	<b>10 Mechanical, Packaging, and Orderable Information</b> .....	<b>59</b>
6.3 Feature Description.....	16		

## 4 Pin Configuration and Functions



図 4-1. PAP0064E Package 64-Pin HTQFP Top View

表 4-1. Pin Functions

NO.	NAME	TYPE <sup>(1)</sup>	DESCRIPTION
1	MUXOUT	O	Multiplexed pin serial data readback (SDO) and lock status of the multiplier.
2	CE	I	Chip Enable
3	SYSREFREQ_P	I	Differential SYSREF request input for JESD204B/C support. Internal 50Ω AC coupled to internal common-mode voltage or capacitor to GND. Supports AC and DC coupling which can directly accept a common mode voltage of 1.2V to 2V.

表 4-1. Pin Functions (続き)

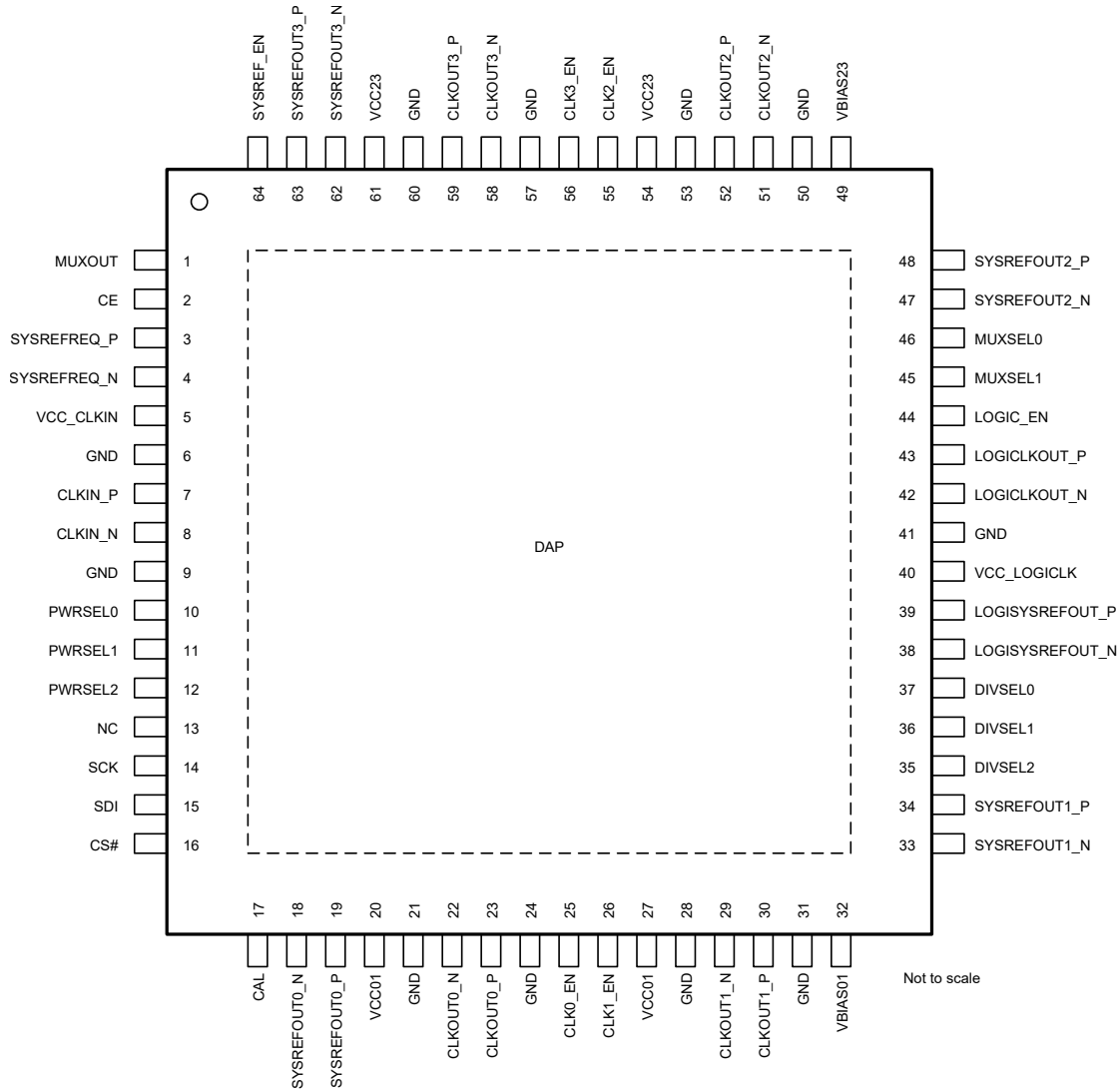
NO.	NAME	TYPE <sup>(1)</sup>	DESCRIPTION
4	SYSREFREQ_N	I	Differential SYSREF request input for JESD204B/C support. Internal 50Ω AC coupled to internal common-mode voltage or capacitor to GND. Supports AC and DC coupling which can directly accept a common mode voltage of 1.2V to 2V.
5	VCC_CLKIN	PWR	Connect to a 2.5V supply. Recommend a shunt RF wideband capacitor (typically 0.1μF or smaller) close to the pin in parallel with larger capacitors (typically 1μF and 10μF). Large capacitors can be placed further away from the pin.
6	GND	GND	Ground these pins.
7	CLKIN_P	I	Differential reference input clock. Internal 50Ω termination. AC-couple with a capacitor appropriate to the input frequency (typically 0.1μF or smaller). If using single-ended, terminate unused pin with 50Ω resistor AC-coupled to ground.
8	CLKIN_N		
9	GND	GND	Ground these pins.
10	PWRSEL0	I	Selects output power level in pin mode.
11	PWRSEL1	I	Selects output power level in pin mode.
12	PWRSEL2	I	Selects output power level in pin mode.
13	NC	NC	No connect pin (Connect to ground with 1kΩ resistor.)
14	SCK	I	SPI clock. High impedance CMOS input. Accepts up to 3.3V.
15	SDI	I	SPI data input. High impedance CMOS input. Accepts up to 3.3V.
16	CS#	I	SPI chip select. High impedance CMOS input. Accepts up to 3.3V.
17	CAL	I	Calibration pin used in multiplier mode.
18	SYSREFOUT0_N	O	Differential SYSREF CML output pairs for JESD204B/C support. Supports AC and DC coupling with programmable common-mode voltage of 0.6V to 2V.
19	SYSREFOUT0_P	O	Differential SYSREF CML output pairs for JESD204B/C support. Supports AC and DC coupling with programmable common-mode voltage of 0.6V to 2V.
20	VCC01	PWR	Connect to a 2.5V supply. Recommend a shunt RF wideband capacitor (typically 0.1μF or smaller) close to the pin in parallel with larger capacitors (typically 1μF and 10μF). Large capacitors can be placed bit further away from the pin.
21	GND	GND	Ground these pins.
22	CLKOUT0_N	O	Differential clock output pairs. Each pin is an open-collector output with internally integrated 50Ω resistor with programmable output swing. AC coupling required.
23	CLKOUT0_P	O	Differential clock output pairs. Each pin is an open-collector output with internally integrated 50Ω resistor with programmable output swing. AC coupling required.
24	GND	GND	Ground these pins.
25	CLK0_EN	I	Enable / Disable the individual output channel.
26	CLK1_EN	I	Enable / Disable the individual output channel.
27	VCC01	PWR	Connect to a 2.5V supply. Recommend a shunt RF wideband capacitor (typically 0.1μF or smaller) close to the pin in parallel with larger capacitors (typically 1μF and 10μF). Large capacitors can be placed bit further away from the pin.
28	GND	GND	Ground these pins.
29	CLKOUT1_N	O	Differential clock output pairs. Each pin is an open-collector output with internally integrated 50Ω resistor with programmable output swing. AC coupling required.
30	CLKOUT1_P	O	Differential clock output pairs. Each pin is an open-collector output with internally integrated 50Ω resistor with programmable output swing. AC coupling required.

**表 4-1. Pin Functions (続き)**

NO.	NAME	TYPE <sup>(1)</sup>	DESCRIPTION
31	GND	GND	Ground these pins.
32	VBIAS01	BYP	Bypass this pin to GND with a 10nF capacitor for optimal noise performance in multiplier mode.
33	SYSREFOUT1_N	O	Differential SYSREF CML output pairs for JESD204B/C support. Supports AC and DC coupling with programmable common-mode voltage of 0.6V to 2V.
34	SYSREFOUT1_P	O	Differential SYSREF CML output pairs for JESD204B/C support. Supports AC and DC coupling with programmable common-mode voltage of 0.6V to 2V.
35	DIVSEL2	I	Select the divider value or multiplier value in divider or multiplier mode in pin configuration.
36	DIVSEL1	I	Select the divider value or multiplier value in divider or multiplier mode in pin configuration.
37	DIVSEL0	I	Select the divider value or multiplier value in divider or multiplier mode in pin configuration.
38	LOGISYSREFOUT_N	O	Differential clock output pair. Selectable CML, or LVDS format. Programmable common-mode voltage.
39	LOGISYSREFOUT_P	O	Differential clock output pair. Selectable CML, or LVDS format. Programmable common-mode voltage.
40	VCC_LOGICLK	PWR	Connect to a 2.5V supply. Recommend a shunt RF wideband capacitor (typically 0.1μF or smaller) close to the pin in parallel with larger capacitors (typically 1μF and 10μF). Large capacitors can be placed bit further away from the pin.
41	GND	GND	Ground these pins.
42	LOGICLKOUT_N	O	Differential clock output pair. Selectable CML, or LVDS format. Programmable common-mode voltage.
43	LOGICLKOUT_P	O	Differential clock output pair. Selectable CML, or LVDS format. Programmable common-mode voltage.
44	LOGIC_EN	I	Enable / disable the logic channel in pin mode.
45	MUXSEL1	I	Select the operating mode buffer, divider or multiplier in pin mode configuration.
46	MUXSEL0	I	Select the operating mode buffer, divider or multiplier in pin mode configuration.
47	SYSREFOUT2_N	O	Differential SYSREF CML output pairs for JESD204B/C support. Supports AC and DC coupling with programmable common-mode voltage of 0.6V to 2V.
48	SYSREFOUT2_P	O	Differential SYSREF CML output pairs for JESD204B/C support. Supports AC and DC coupling with programmable common-mode voltage of 0.6V to 2V.
49	VBIAS23	BYP	Bypass this pin to GND with a 10μF and 0.1μF capacitor for optimal noise performance in multiplier mode.
50	GND	GND	Ground these pins.
51	CLKOUT2_N	O	Differential clock output pairs. Each pin is an open-collector output with internally integrated 50Ω resistor with programmable output swing. AC coupling required.
52	CLKOUT2_P	O	Differential clock output pairs. Each pin is an open-collector output with internally integrated 50Ω resistor with programmable output swing. AC coupling required.
53	GND	GND	Ground these pins.
54	VCC23	PWR	Connect to a 2.5V supply. Recommend a shunt RF wideband capacitor (typically 0.1μF or smaller) close to the pin in parallel with larger capacitors (typically 1μF and 10μF). Large capacitors can be placed bit further away from the pin.
55	CLK2_EN	I	Enable / Disable the individual output channel.

表 4-1. Pin Functions (続き)

NO.	NAME	TYPE <sup>(1)</sup>	DESCRIPTION
56	CLK3_EN	I	Enable / Disable the individual output channel.
57	GND	GND	Ground these pins.
58	CLKOUT3_N	O	Differential clock output pairs. Each pin is an open-collector output with internally integrated 50Ω resistor with programmable output swing. AC coupling required.
59	CLKOUT3_P	O	Differential clock output pairs. Each pin is an open-collector output with internally integrated 50Ω resistor with programmable output swing. AC coupling required.
60	GND	GND	Ground these pins.
61	VCC23	PWR	Connect to a 2.5V supply. Recommend a shunt RF wideband capacitor (typically 0.1μF or smaller) close to the pin in parallel with larger capacitors (typically 1μF and 10μF). Large capacitors can be placed bit further away from the pin.
62	SYSREFOUT3_N	O	Differential SYSREF CML output pairs for JESD204B/C support. Supports AC and DC coupling with programmable common-mode voltage of 0.6V to 2V.
63	SYSREFOUT3_P	O	Differential SYSREF CML output pairs for JESD204B/C support. Supports AC and DC coupling with programmable common-mode voltage of 0.6V to 2V.
64	SYSREF_EN	I	Enable / disable the SYSREF section in pin mode configuration.
DAP	DAP	GND	Ground the pad.

(1) I = Input, O = Output, GND = Ground, PWR = Power, BYP = Bypass

## 5 Specifications

### 5.1 Absolute Maximum Ratings

over operating free-air temperature range (unless otherwise noted)<sup>(1)</sup>

		MIN	MAX	UNIT
V <sub>DD</sub>	Power supply voltage	−0.3	2.75	V
V <sub>IN</sub>	DC Input Voltage (SCK, SDI, CSB)	GND	3.6	V
V <sub>IN</sub>	DC Input Voltage (SYSREFREQ)	GND	V <sub>DD</sub> + 0.3	V
V <sub>IN</sub>	AC Input Voltage (CLKIN)		2.1	V <sub>pp</sub>
T <sub>J</sub>	Junction temperature		150	°C
T <sub>stg</sub>	Storage temperature	−65	150	°C

- (1) Operation outside the Absolute Maximum Ratings may cause permanent device damage. Absolute Maximum Ratings do not imply functional operation of the device at these or any other conditions beyond those listed under Recommended Operating Conditions. If used outside the Recommended Operating Conditions but within the Absolute Maximum Ratings, the device may not be fully functional, and this may affect device reliability, functionality, performance, and shorten the device lifetime.

### 5.2 ESD Ratings

			VALUE	UNIT
V <sub>(ESD)</sub>	Electrostatic discharge	Human body model (HBM), per ANSI/ESDA/JEDEC JS-001, all pins <sup>(1)</sup>	±2500	V
		Charged device model (CDM), per ANSI/ESDA/JEDEC JS-002, all pins <sup>(2)</sup>	±250	

- (1) JEDEC document JEP155 states that 500V HBM allows safe manufacturing with a standard ESD control process.  
(2) JEDEC document JEP157 states that 250V CDM allows safe manufacturing with a standard ESD control process.

### 5.3 Recommended Operating Conditions

over operating free-air temperature range (unless otherwise noted)

		MIN	NOM	MAX	UNIT
V <sub>DD</sub>	Supply voltage	2.4	2.5	2.6	V
T <sub>C</sub>	Case Temperature	−55		125	°C

### 5.4 Thermal Information

SYMBOL	THERMAL MATRIC <sup>(1)</sup>	PAP (HTQFP)	UNIT
		64 PINS	UNIT
R <sub>θJA</sub>	Junction-to-ambient thermal resistance	21.7	°C/W
R <sub>θJC(top)</sub>	Junction-to-case (top) thermal resistance	9.1	°C/W
R <sub>θJB</sub>	Junction-to-board thermal resistance	7.3	°C/W
Ψ <sub>JT</sub>	Junction-to-top characterization parameter	0.1	°C/W
Ψ <sub>JB</sub>	Junction-to-board characterization parameter	7.2	°C/W
R <sub>θJC(bot)</sub>	Junction-to-case (bottom) thermal resistance	0.6	°C/W

- (1) For more information about traditional and new thermal metrics, see the [Semiconductor and IC Package Thermal Metrics](#) application note.

## 5.5 Electrical Characteristics

2.4V ≤ V<sub>DD</sub> ≤ 2.6V, -55°C ≤ T<sub>C</sub> ≤ +125°C. Typical values are at V<sub>DD</sub> = 2.5V, 25°C (unless otherwise noted)

PARAMETER		TEST CONDITIONS		MIN	TYP	MAX	UNIT
<b>Current Consumption</b>							
I <sub>CC</sub>	Supply Current <sup>(1)</sup>	Powered up, all outputs and SYSREF on		1050		mA	
		Powered up, all outputs on, all SYSREF off		600			
		Powered up, all outputs and SYSREF off		265			
		Powered down <sup>(2)</sup>		11			
<b>SYSREF</b>							
f <sub>SYSREF</sub>	SYSREF output frequency	Generator mode		200		MHz	
		Repeater mode		100		MHz	
Δt	SYSREF delay step size	f <sub>CLKIN</sub> = 12.8GHz		3		ps	
t <sub>RISE</sub>	Rise time (20% to 80%)	SYSREFOUT		45		ps	
		LOGISYSREFOUT	CML	120		ps	
			LVDS	120		ps	
t <sub>FALL</sub>	Fall time (20% to 80%)	SYSREFOUT		45		ps	
		LOGISYSREFOUT	CML	120		ps	
			LVDS	120		ps	
V <sub>OD</sub>	Differential output voltage	SYSREFOUT		0.85		V <sub>pp</sub>	
		LOGISYSREFOUT	CML	0.4		V <sub>p</sub>	
			LVDS	0.4		V <sub>p</sub>	
V <sub>SYSREFCM</sub>	Common mode voltage	SYSREFOUT	CML SYSREFOUT <sub>x_PW</sub> R=4 100Ω Differential Load	0.8		V	
<b>SYSREFREQ Pins</b>							
V <sub>SYSREFIN</sub>	Voltage input range	AC differential voltage		0.8	2		V <sub>pp</sub>
V <sub>CM</sub>	Input common mode	Differential 100Ω Termination, DC coupled Set externally		1.2	1.3	2	V
<b>Clock Input</b>							
f <sub>IN</sub>	Input frequency	Buffer Mode Only		0.3	15 <sup>(3)</sup>		GHz
P <sub>IN</sub>	Input power	Single-ended power at CLKIN_P or CLKIN_N		0	10		dBm
<b>Clock Outputs</b>							
f <sub>OUT</sub>	Output frequency	Divide-by-2		0.15	6.4		GHz
f <sub>OUT</sub>	Output frequency	Buffer Mode		0.3	15 <sup>(3)</sup>		
f <sub>OUT</sub>	Output frequency	x2, x3, x4		3.2	6.4		
f <sub>OUT</sub>	Output frequency	LOGICLK output		1	800		MHz
t <sub>CAL</sub>	Calibration-time	Multiplier calibration time	f <sub>IN</sub> = 3.2GHz; x2 f <sub>SMCLK</sub> = 28MHz	750		μs	
P <sub>OUT</sub>	Output power	Single-Ended	f <sub>CLKLOUT</sub> = 6GHz OUT <sub>x_PWR</sub> = 7	6		dBm	
			f <sub>CLKLOUT</sub> = 12.8GHz OUT <sub>x_PWR</sub> = 7	0			
			f <sub>CLKLOUT</sub> = 15GHz OUT <sub>x_PWR</sub> = 7	-3			
t <sub>RISE</sub>	Rise time (20% to 80%)	f <sub>CLKOUT</sub> = 300MHz		45		ps	
t <sub>FALL</sub>	Fall time (20% to 80%)	f <sub>CLKOUT</sub> = 300MHz		45		ps	
t <sub>MUTE</sub>	Output mute time	Falling edge of OE pin		30		μs	



2.4V ≤ V<sub>DD</sub> ≤ 2.6V, -55°C ≤ T<sub>C</sub> ≤ +125°C. Typical values are at V<sub>DD</sub> = 2.5V, 25°C (unless otherwise noted)

PARAMETER		TEST CONDITIONS		MIN	TYP	MAX	UNIT
t <sub>UNMUTE</sub>	Output unumte time	Rising edge of OE pin				30	μs
<b>Propogation Delay and Skew</b>							
t <sub>SKEW</sub>	Magnitude of skew between outputs	T <sub>A</sub> = -55°C to +125°C			2.5	10	ps
Δt <sub>DLY</sub> /ΔT	Propagation delay variation over temp	Buffer Mode		0.02	0.06	0.1	ps/C
t <sub>DLY</sub>	Propagation delay	Buffer Mode	T <sub>A</sub> = 25°C			180	ps
		Divider Mode				182	
		Multiplier Mode				185	
<b>Noise, Jitter, and Spurs</b>							
J <sub>CKx</sub>	Additive jitter	Additive Jitter. 12kHz to 100MHz integration bandwidth.	Buffer Mode			5	fs, rms
			x2 Multiplier			16	
			x3 Multiplier			21	
			x4 Multiplier			26	
Flicker	1/f flicker noise	Slew Rate > 8V/ns, f <sub>CLK</sub> =6GHz	Buffer Mode			-155	dBc/Hz
NFL	Noise Floor	f <sub>OUT</sub> = 6GHz; f <sub>offset</sub> = 100MHz	Buffer Mode			-159	dBc/Hz
NFL			Divide-by-2			-158.5	
NFL			Multiplier (x2,x3,x4)			-159.5	
NFL	Noise Floor	LOGICLK output, 300MHz	CML			-150.5	dBc/Hz
NFL			LVDS			-151.5	
H2	Second harmonic	f <sub>OUT</sub> = 6GHz (differential), Buffer Mode			-25	dBc	
			f <sub>OUT</sub> = 6GHz (single-ended), Buffer Mode		-13		
			f <sub>OUT</sub> = 6GHz, single-ended, Divide by 2		-16		
H1/2	Input clock leakage spur	f <sub>OUT</sub> = 6GHz (single-ended)	x2 (f <sub>SPUR</sub> = 3GHz)			-40	dBc
H1/3			x3 (f <sub>SPUR</sub> = 2GHz)			-50	
H1/4			x4 (f <sub>SPUR</sub> = 1.5GHz)			-54	
I <sub>SPUR</sub>	LOGICLK to CLKOUT	f <sub>SPUR</sub> = 300MHz (differential)			-70		dBc
<b>Digital Interface (SCK, SDI, CS#, MUXOUT,CLKx_EN,MUXSELx,PWRSELx,DIVSELx,LOGIC_EN,SYSREF_EN,CAL,CE)</b>							
V <sub>IH</sub>	High-level input voltage	SCK, SDI, CS#		1.4		3.3	V
	High-level input voltage	CLKx_EN,MUXSELx,PWRSELx,DIVSELx,LOGIC_EN,SYSREF_EN,CAL,CE		1.4		3.3	V
V <sub>IL</sub>	Low-level input voltage	SCK, SDI, CS#		0		0.4	V
	Low-level input voltage	CLKx_EN,MUXSELx,PWRSELx,DIVSELx,LOGIC_EN,SYSREF_EN,CAL,CE		0		0.4	V
I <sub>IH</sub>	High-level input current	SCK, SDI, CS#		-42		42	μA
	High-level input current	CLKx_EN,MUXSELx,PWRSELx,DIVSELx,LOGIC_EN,SYSREF_EN,CAL,CE		-42		42	μA
I <sub>IL</sub>	Low-level input current	SCK, SDI, CS#		-25		25	μA
	Low-level input current	CLKx_EN,MUXSELx,PWRSELx,DIVSELx,LOGIC_EN,SYSREF_EN,CAL,CE		-25		25	μA
V <sub>OH</sub>	High-level output voltage	MUXOUT	I <sub>OH</sub> = 5mA	1.4		2.2	V
	High-level output voltage		I <sub>OH</sub> = 0.1mA	2.2		2.5	V
V <sub>OL</sub>	Low-level output voltage	MUXOUT	I <sub>OL</sub> = 5mA			0.45	V

- (1) Unless Otherwise Stated, f<sub>CLKIN</sub>=6GHz, CLK\_MUX=Buffer, All clocks on with OUTx\_PWR=7, SYSREFREQ\_MODE=1.
- (2) For powered down mode.
- (3) SYNC, divider, SYSREF and SYSREF windowing supported up to 12.8GHz frequency.

## 5.6 Timing Requirements

		MIN	NOM	MAX	UNIT
<b>Timing Requirements</b>					
$f_{SPI}$	SPI Read/Write Speed			2	MHz
$t_{CE}$	Clock to enable low time	20			ns
$t_{CS}$	Clock to data wait time	20			ns
$t_{CH}$	Clock to data hold time	20			ns
$t_{CWH}$	Clock pulse width high	100			ns
$t_{CWL}$	Clock pulse width low	100			ns
$t_{CES}$	Enable to clock setup time	20			ns
$t_{EWH}$	Enable pulse width high	50			ns
$t_{CD}$	Falling clock edge to data wait time	0		100	ns

## 5.7 Timing Diagram



図 5-1. Serial Data Input Timing Diagram

There are several other considerations for writing on the SPI:

- The R/W bit must be set to 0.
- The data on SDI pin is clocked into a shift register on each rising edge on the SCK pin.
- The CS# must be held low for data to be clocked. The device ignores clock pulses if CS# is held high.
- Recommended SPI settings for this device are CPOL=0 and CPHA=0.
- When SCK and SDI lines are shared between devices, TI recommends to hold the CS# line high on the device that is not to be clocked.

There are several other considerations for SPI readback:

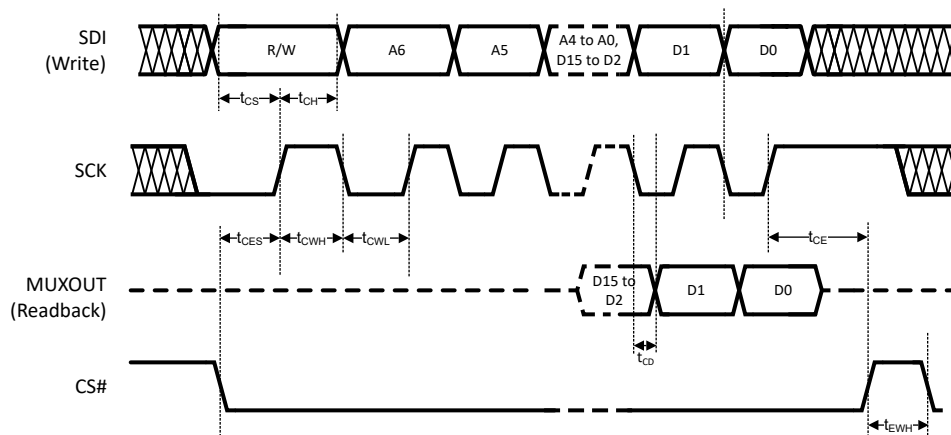
- The R/W bit must be set to 1.
- The MUXOUT pin is always be low for the address portion of the transaction.
- The data on MUXOUT is clocked out at the falling edge of SCK. In other words, the readback data is available at the MUXOUT pin  $t_{CD}$  after the clock falling edge.
- The data portion of the transition on the SDI line is always ignored.
- The MUXOUT pin does not automatically tri-state after a readback transaction completes. When sharing the SPI bus readback pin with other devices, set MUXOUT\_EN=0 after all readback transactions from device are complete to manually tri-state the MUXOUT pin, permitting other devices to control the readback line.
- The values read back, even for R/W bits are not always the value written but rather an internal device state that takes into account the programmed value as well as other factors, such as pin states.

## 5.8 Typical Characteristics

If not otherwise, the following conditions can be assumed: Temperature = 25°C,  $V_{DD} = 2.5V$ ,  $OUTx\_PWR = 5$ , CLKIN driven differentially with 8dBm at each pin. Signal source used is Rohde & Schwarz® SMA100B with ultra-low noise option B711.

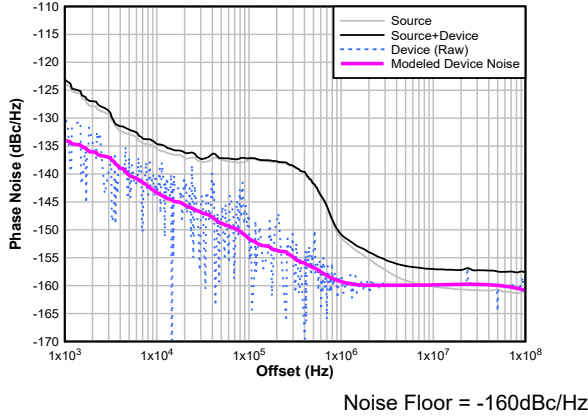

5-2. Buffer Phase Noise Plot at 6GHz Output

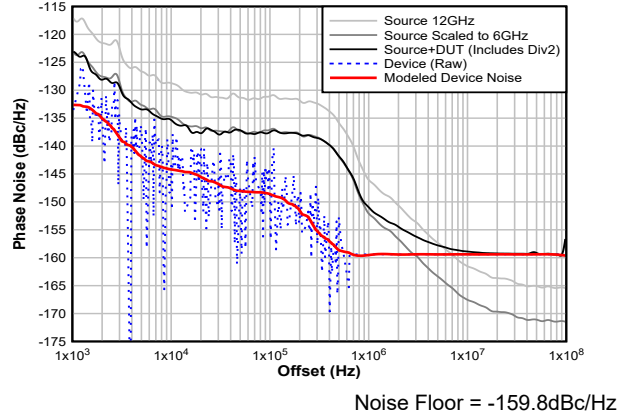

5-3. Divider Phase Noise Plot at 6GHz Output (Divide by 2)

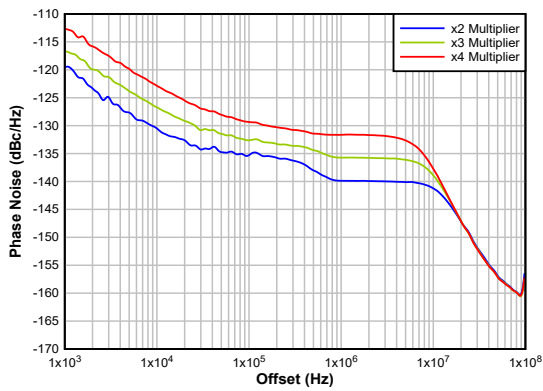

5-4. Multiplier Phase Noise Plot at 6GHz Output

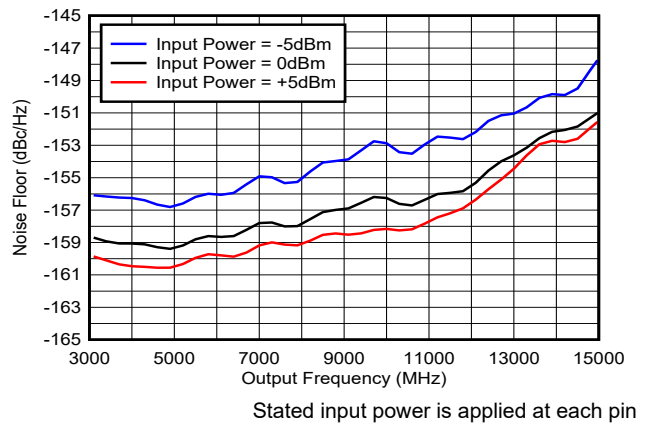

5-5. Noise Floor in Buffer Mode

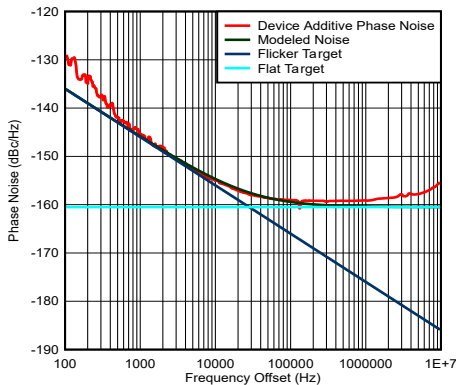

5-6. Flicker Noise

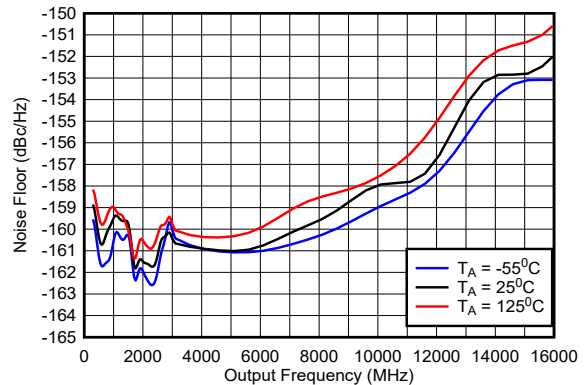

5-7. Noise Floor in Buffer Mode

### 5.8 Typical Characteristics (continued)

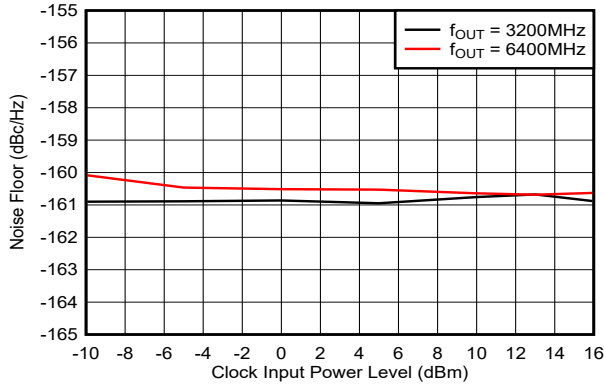

Input is differential  
**图 5-8. Noise Floor in Multiply x2 Mode**

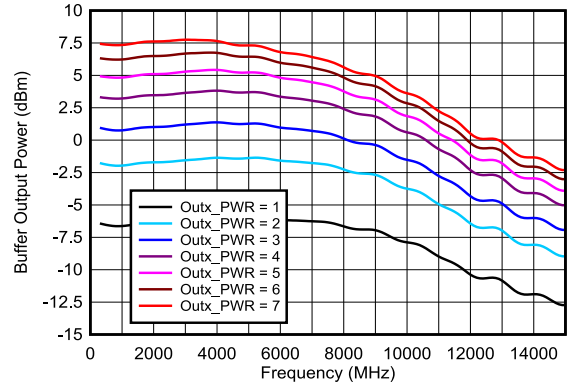

Applies to all modes except divider mode with odd divide (which have slightly lower power).  
**图 5-9. Buffer Mode Single-Ended Output Power**

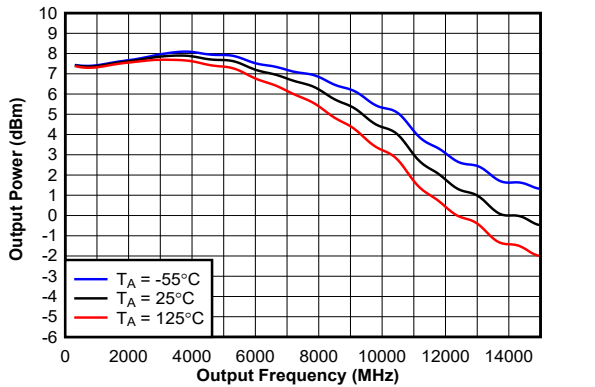

CLKOUTx\_PWR = 7  
**图 5-10. Buffer Mode Single-Ended Output Power**

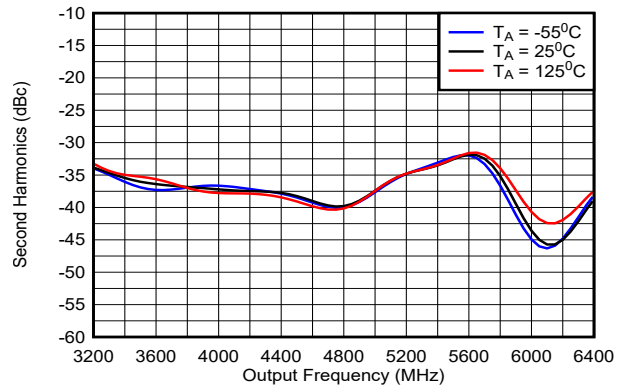

**图 5-11. Second Harmonic in Multiply X2 Mode (Differential Output)**

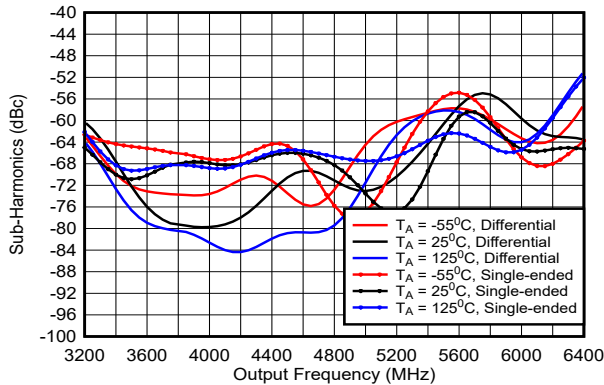

**图 5-12. Multiplier 1/2 Sub-Harmonic in X2 Mode**

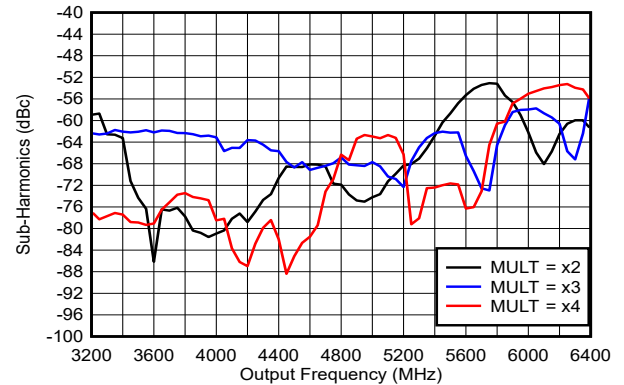

**图 5-13. Multiplier Sub-Harmonics (Harmonic Frequency = Output Frequency / M)**

### 5.8 Typical Characteristics (continued)



图 5-14. Second Harmonic on Divider Mode (Single-Ended Input)



图 5-15. Output to Output Skew (ps)

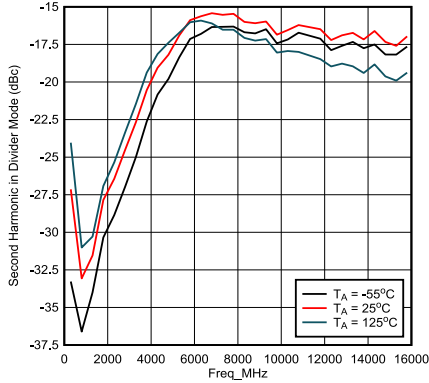

图 5-16. SYSREF Delta Delay vs. Code

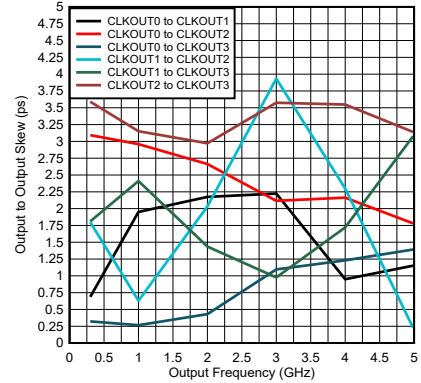

Measured in power-down mode to make Junction Temperature = Ambient Temperature.

图 5-17. Temperature Sensor Readback

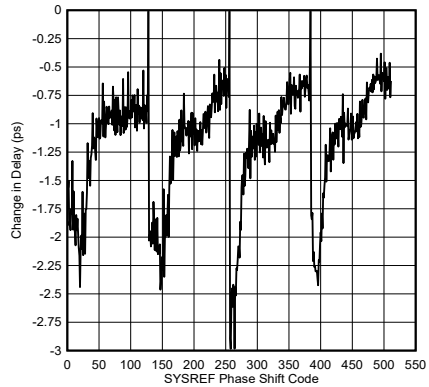
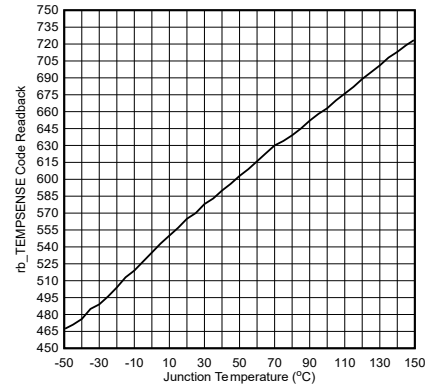

图 5-18. Propagation Delay



图 5-19. Channel Enable Setting Time

## 5.8 Typical Characteristics (continued)

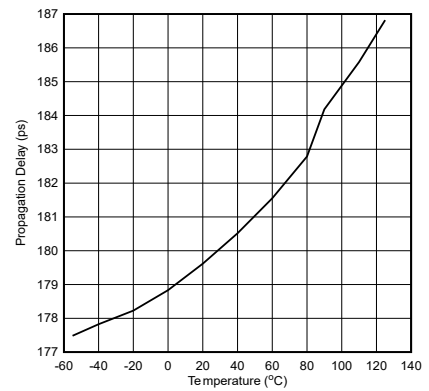

図 5-20. Channel Disable Setting Time

## 6 Detailed Description

### 6.1 Overview

This device has four main clock outputs and another LOGICLK output. The main clock outputs are all the same frequency. This frequency can be the same, divided, or multiplied relative to the input clock. Each of these clock outputs has programmable power level. The LOGICLK output frequency is independent and typically lower frequency than the other four main clocks and has programmable output format (CML and LVDS) and power level.

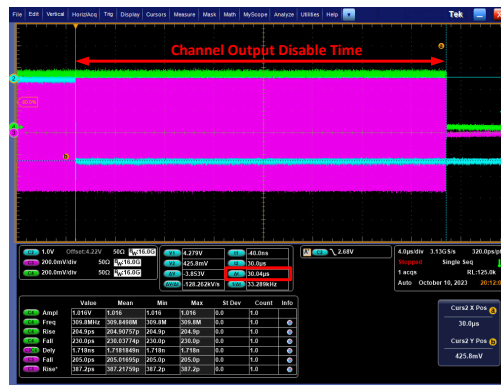
The SYSREF can be generated by either repeating the input from the SYSREFREQ pins, or internally generated. There is an internal SYSREF windowing feature that allows the internal timing of the device to be adjusted to optimize setup and hold times of the SYSREFREQ input with respect to the CLKIN input. This feature assumes that the delay between the SYSREF edge and the next rising clock edge is consistent. Each of the five outputs has a corresponding SYSREF output that has individual delays and programmable common mode. For the LOGISYSREF output, the output format is programmable as CML or LVDS.

#### 6.1.1 Range of Dividers and Multiplier

There are dividers that allow the main and LOGICLK outputs to be a divided value of the input clock. The main clock outputs also have a multiplier. In addition to this, dividers are used for SYSREF generation in generator mode as well as generation of the delay block.

表 6-1. Range of Dividers and Multiplier

CATEGORY		RANGE	COMMENTS
Main Clocks	Buffer		
	Divider <sup>(1)</sup>	2, 3, 4, ... 8	Odd divides (except 1) do not have 50% duty cycle
	Multiplier	2, 3, 4	
LOGICLK	Divide	PreDivide	1, 2, 4 TotalDivide = PreDivide × Divide
		Divide	1, 2, 3, ... 1023 Odd divides (except 1) do not have 50% duty cycle
SYSREF	Divide for frequency generation	PreDivide	1, 2, 4 TotalDivide = PreDivide × Divide
		Divide	2, 3, 4, ... 4095 Odd divides do not have 50% duty cycle
	Divide for delay generation	Divide	2, 4, 8, 16 This divide is for phase interpolator and set according to the input frequency.

(1) Divide /6 and /8 does not support SEFI compliant

## 6.2 Functional Block Diagram

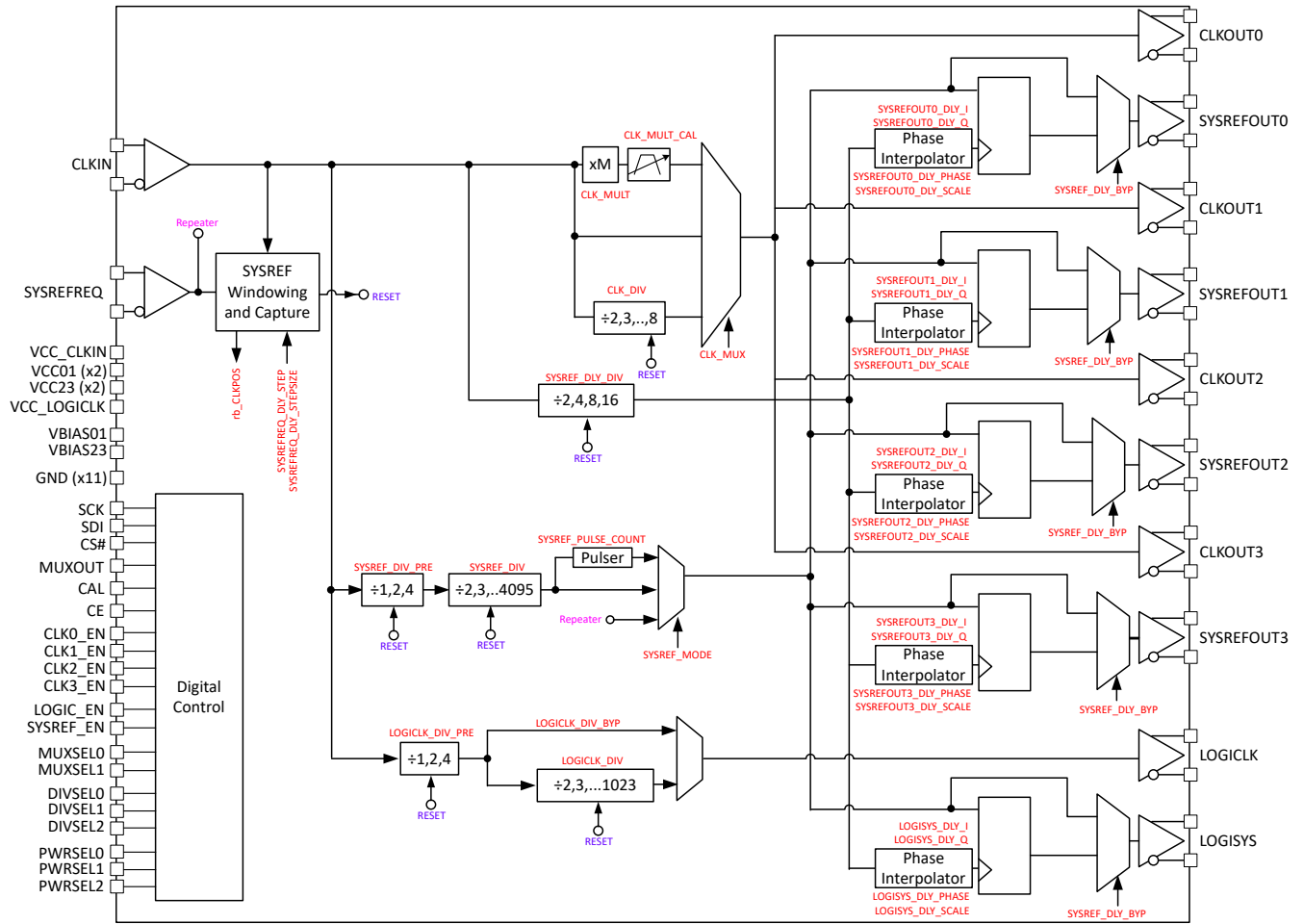

6-1. Functional Block Diagram

## 6.3 Feature Description

### 6.3.1 Power On Reset

When the device is powered up, the power-on reset (POR) resets all registers to a default state as well as resets all state machines and dividers. For the power on reset state, all SYSREF outputs are disabled and all the dividers are bypassed and the device performs as a 4-output buffer. Wait approximately 100µs after the power supply rails before programming other registers to verify that this reset is finished. The device functions properly if the power-on reset happens when no device clock is present, but the current changes after an input clock is inserted.

Performing a software power on reset by writing RESET = 1 in the SPI bus is possible and generally good practice. The RESET bit self-clears when the user writes to any other register. The SPI bus can be used to override these states to the desired settings.

Although the device does have an automatic power on reset, the can be impacted by different ramp rates on the different supply pins, especially in the presence of a strong input clock signal. TI therefore recommends to do a software reset after POR. This can be done by programming RESET = 1. The reset bit can be cleared by programming any other register or setting RESET back to 0. Even at the maximum allowed SPI bus speed, the software reset event always completes before the subsequent SPI write.

### 6.3.2 Temperature Sensor

The junction temperature can be read back for purposes such as characterization or to make adjustments based on temperature. Such adjustments can include adjusting CLKOUTx\_PWR to make the output power more stable or using external or digital delays to compensate for changes in propagation delay over temperature.

The junction temperature is typically higher than the ambient temperature due to power dissipation from the outputs and other functions on the device. 式 1 shows the relationship between the code read back and the junction temperature.

$$\text{Temperature} = 0.65 \times \text{Code} - 351 \quad (1)$$

式 1 is based on a best-fit line created from three devices from slow, nominal, and fast corner lots (nine parts total). The worst-case variation of the actual temperature from the temperature predicted by the best-fit line is 13°C, which works out to 20 codes.

### 6.3.3 Clock Outputs

This device has four main output clocks which share a common frequency. This does not include the additional lower frequency LOGICLK output.

#### 6.3.3.1 Clock Output Buffers

The output buffers have a format that is open collector with an integrated pullup resistor, similar to CML.





図 6-2. CLKOUT Output Buffer

The CLKOUT<sub>x</sub>\_EN bits can enable the output buffers. The output power of the buffers can be individually set with CLKOUT<sub>x</sub>\_PWR field. However, these fields only control the output buffer, not the internal channel path that drives this buffer. To power down the entire path, disable the CH<sub>x</sub>\_EN bit.

表 6-2. Clock Output Power

CH <sub>x</sub> _EN	INTERNAL CHANNEL PATH	CLKOUT <sub>x</sub> _EN	CLKOUT <sub>x</sub> _PWR	OUTPUT BUFFER
0	Powered Down	Don't Care	Don't Care	Powered Down
1	Powered Up	1	0	Powered Down
			1	Minimum
			...	
			7	Maximum

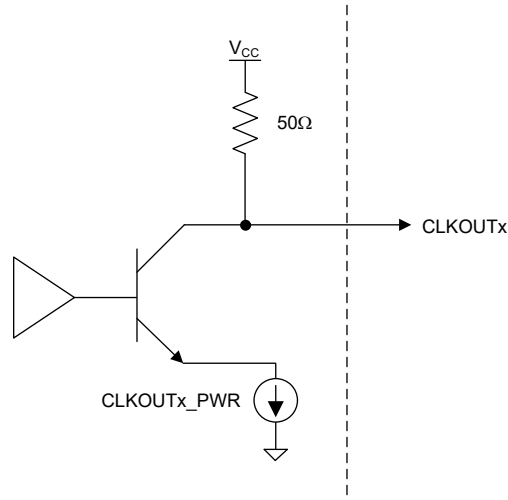
### 6.3.3.2 Clock MUX

The four main clocks must be the same frequency, but this frequency can be bypassed, multiplied, or divided. This is determined by the CLK\_MUX word.

表 6-3. Clock MUX

CLK_MUX	OPTION	VALUES SUPPORTED
0	Buffer Mode	+1 (bypass)
1	Divider Mode	+2, 3, 4, 5, 6, 7, and 8
2	Multiplier Mode	x2, x3, x4

### 6.3.3.3 Clock Divider

Set the CLK\_MUX to Divided to a divide value by 2, 3, 4, 5, 6, 7, or 8. This is set by the CLK\_DIV word. When using the clock divider, any change to the input frequency requires the CLK\_DIV\_RST bit to be toggled from 1 to 0.

表 6-4. Clock Divider

CLK_DIV	DIVIDE	DUTY CYCLE
0	Reserved	n/a
1	2	50%
2	3	33%

**表 6-4. Clock Divider (続き)**

CLK_DIV	DIVIDE	DUTY CYCLE
3	4	50%
4	5	40%
5	6	50%
6	7	43%
7	8	50%

### 6.3.3.4 Clock Multiplier

#### 6.3.3.4.1 General Information about the Clock Multiplier

Use the clock multiplier to multiply up the input clock frequency by a factor of x2, x3, or x4. The multiply value is set by the CLK\_MULT field. As the multiplier is PLL-based and includes an integrated VCO, the multiplier has a state machine clock, requires calibration, has a lock detect feature.

#### 6.3.3.4.2 State Machine Clock for the Clock Multiplier

The state machine clock frequency ( $f_{SMCLK}$ ) is derived by dividing down the input clock frequency by a programmed divider value. The state machine clock is also necessary for the multiplier calibration and lock detect. If there are concerns about the state machine clock creating spurs, then the state machine clock can be shut off, provided that the multiplier calibration is not running and the lock detect feature is not in use.

##### 6.3.3.4.2.1 State Machine Clock

A valid state machine clock is required (SMCLK\_EN=1 and signal present at CLKIN pins) in below circumstances:

1. Multiplier is being calibrated.
2. Lock Detect from the multiplier is being monitored.
3. Clock divide value is being changed to 6 or 8.
4. For the device to perform a proper power on reset.
  - a. Note that SMCLK\_EN=1 is enabled by the power on reset, but an input clock is also required to allow the power on reset before SMCLK\_EN can be set to 0.

When the state machine clock is enabled, the clock needs to be less than 30MHz and the frequency is as follows:

$$f_{SMCLK} = f_{CLKIN} / (SMCLK\_DIV\_PRE * SMCLK\_DIV)$$

When the state machine clock is not required, the clock can be disabled by setting SMCLK\_EN=0 to minimize crosstalk and spurs.

#### 6.3.3.4.3 Calibration for the Clock Multiplier

For optimal phase noise, the VCO in the multiplier divides up the frequency range into many different bands and cores and has optimized amplitude settings for each band and core. For this reason, upon initial use or whenever the frequency is changed, the user must run a calibration routine to determine the correct core, frequency band, and amplitude setting. Program the R0 register with a valid input signal to perform a calibration. To provide reliable multiplier calibration, the state machine clock frequency must be at least twice the SPI write speed, but no more than 30MHz. Whenever the CLK\_MUX mode is changed or the multiplier is calibrated for the first time, the calibration time is substantially longer, on the order of 5ms.

#### 6.3.3.4.4 Lock Detect for the Clock Multiplier

The lock detect status of the multiplier can be read back through the rb\_LD field or from the MUXOUT pin. The state machine clock must be running for the lock detect to work properly.

### 6.3.3.4.5 Watchdog Timer

The watchdog feature is used when radiation during VCO calibration causes the VCO calibration to fail in multiplier mode. The watchdog timer run during VCO calibration. If this timer runs out before the VCO calibration is finished, then the VCO calibration is restarted. During the watchdog timer operation, state machine clock must be enabled.

### 6.3.4 Device Functional Modes Configurations

The device can configure in high frequency clock buffer mode, divider mode or multiplier mode. Each mode requires the below register configurations to function.

**表 6-5. Device Functional Modes Settings**

REGISTER ADDRESS	BIT	FIELD	FUNCTION	BUFFER	DIVIDER	MULTIPLIER
R25	2:0	CLK_MUX	Select the mode	1	2	3
R25	5:3	CLK_DIV / CLK_MULT	Select the division or multiplication value	x	CLK_DIV 0x1 = +2 0x2 = +3 0x3 = +4 0x4 = +5 0x5 = +6 0x6 = +7 0x7 = +8	CLK_MULT 0x2 = ×2 0x3 = ×3 0x4 = ×4
R2	5	SMCLK_EN	Enables the state machine clock generator	x	x	1
R2	9:6	SMCLK_DIV_PRE	Sets pre-divider for state machine clock	x	x	Pre-clock divider for state machine clock 0x2 = +2 0x4 = +4 0x8 = +8
R3	2:0	SMCLK_DIV	Sets state machine clock divider	x	x	Additional SMCLK divider to keep output frequency must be ≤ 30MHz. 0x0 = +1 0x1 = +2 0x2 = +4 0x3 = +8 0x4 = +16 0x5 = +32 0x6 = +64 0x7 = +128
R0	All	Calibrate Multiplier	Calibrate the PLL based multiplier	x	x	Write R0 for calibrate multiplier

### 6.3.5 LOGICLK Output

The LOGICLK output can be used to drive devices using lower frequency clocks, such as FPGAs. The LOGICLK output has a programmable output format and a corresponding SYSREF output.

### 6.3.5.1 LOGICLK Output Format

The LOGICLK output format can be programmed to LVDS and CML modes. Depending on the format, the common mode can be programmable or external components can be required (see 表 6-6).

**表 6-6. LOGICLK Formats and Properties**

LOGICLKOUT_FMT	FORMAT	EXTERNAL COMPONENTS REQUIRED	OUTPUT LEVEL	COMMON MODE
0	LVDS	None	Fixed	Programmable through LOGICLKOUT_VCM
2	CML	Pullup Resistors 50Ω to V <sub>CC</sub>	Programmable through LOGICLKOUT_PWR	Not programmable

### 6.3.5.2 LOGICLK\_DIV\_PRE and LOGICLK\_DIV Dividers

The LOGICLK\_DIV\_PRE divider and LOGICLK\_DIV dividers are used for the LOGICLK output. The LOGICLK\_DIV\_PRE divider is necessary to divide the frequency down to verify that the input to the LOGICLK\_DIV divider is 3.2GHz or less. When LOGICLK\_DIV is not even and not bypassed, the duty cycle is not 50%. Both the LOGICLK dividers are synchronized by the SYNC feature, which allows synchronization across multiple devices. The dividers LOGICLK\_DIV\_PRE and LOGICLK\_DIV has the default divide value of 4 and 32 respectively.

**表 6-7. Minimum N-Divider Restrictions**

f <sub>CLKIN</sub> (MHz)	LOGICLK_DIV_PRE	LOGICLK_DIV	TOTAL DIVIDE RANGE
f <sub>CLKIN</sub> ≤ 3.2GHz	÷1, 2, 4	÷1, 2, 3,...1023	[1, 2, ...1023] [2, 4, ... 2046] [4, 8, 4092]
3.2GHz < f <sub>CLKIN</sub> ≤ 6.4GHz	÷2, 4	÷1, 2, 3, ...1023	[4, ... 2046] [4, 8, 4092]
f <sub>CLKIN</sub> > 6.4GHz	÷4	1, 2, 3, ...1023	[8, 4092]

### 6.3.6 SYSREF

SYSREF allows a low frequency JESD204B/C compliant signal to be produced that is reclocked to a main or LOGICLK output. The delays between the CLKOUT and SYSREF outputs are adjustable with software. The SYSREF output can be configured as a generator using the internal SYSREF divider, or as a repeater duplicating the signal on the SYSREFREQ pins. The SYSREF generator for both the main clocks and the LOGICLK output are the same.

**表 6-8. SYSREF Modes**

SYSREF_MODE	DESCRIPTION
0	<b>Generator Mode</b> Internal generator creates a continuous stream of SYSREF pulses. The SYSREFREQ pins or the SYSREFREQ_FORCE bit can be used to gate the SYSREF divider from the channels for improved noise isolation without disrupting the synchronization of the SYSREF dividers. The SYSREFREQ pins or the SYSREFREQ_FORCE bit must be high for a SYSREF output to come out.
1	<b>Pulser</b> Internal generator generates a burst of 1 - 16 pulses that is set by SYSREF_PULSE_CNT that occurs after a rising edge on the SYSREFREQ pins or after changing SYSREFREQ_FORCE bit from 0 to 1 (assuming SYSREFREQ pins to be forced to a low state).
2	<b>Repeater Mode</b> SYSREFREQ pins input are reclocked to clock outputs and then delayed in accordance to the SYSREF_DLY_BYP field before sent to the SYSREFOUT output pins.

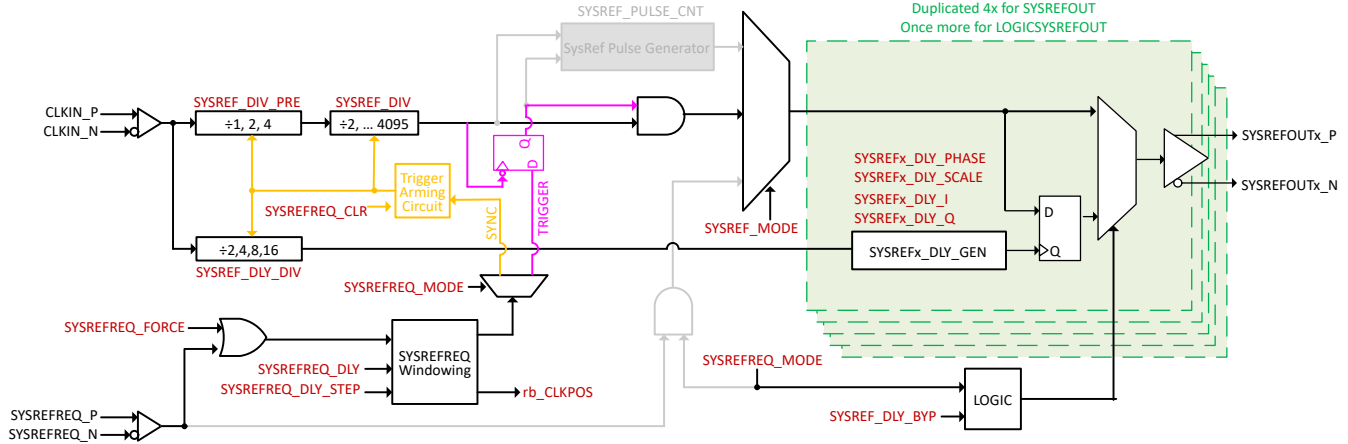

6-3. Functional Block Diagram of SYSREF Circuitry in Generator Mode

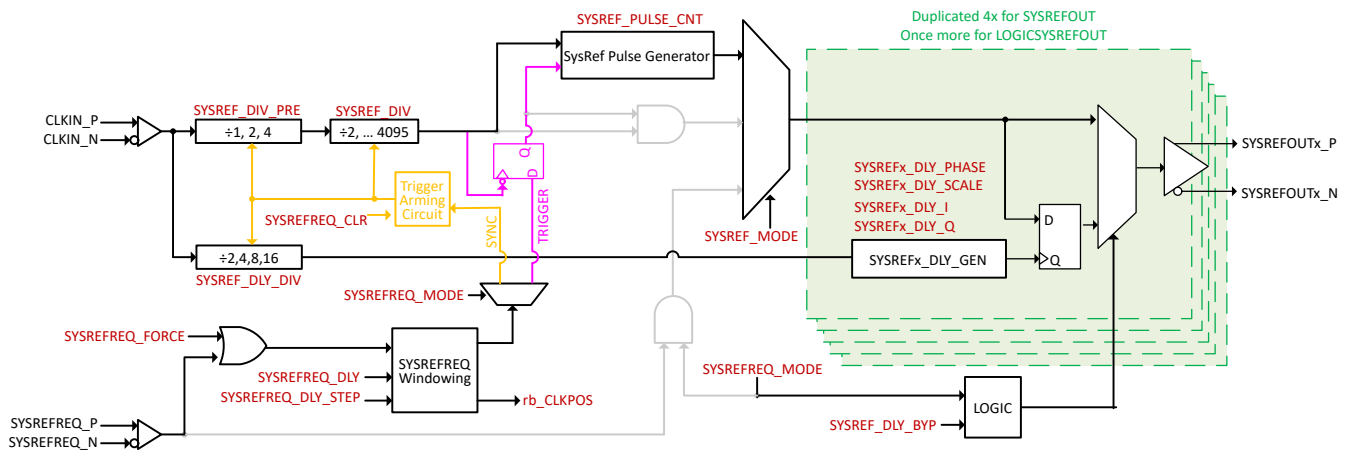

6-4. Functional Block Diagram of SYSREF Circuitry in Pulser Mode

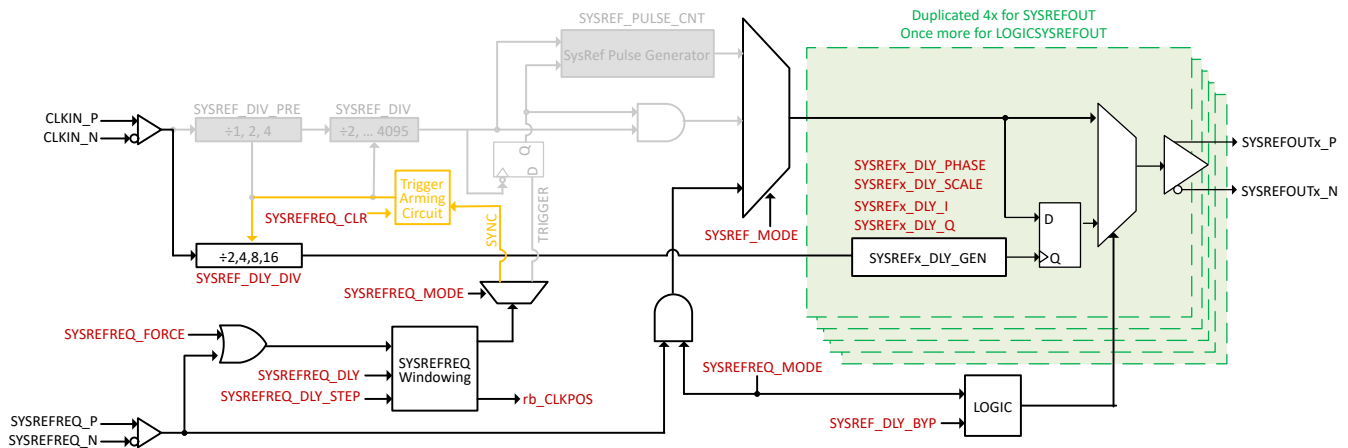

6-5. Functional Block Diagram of SYSREF Circuitry in Repeater Mode

To operate the SYSREF\_FREQ\_FORCE bit controlled SYSREF output (Pulser) and SYNC, set the SYSREF\_FREQ pins to low logic state externally. For example, make sure the SYSREF\_FREQ\_N pin is at a higher level (400mV) than the SYSREF\_FREQ\_P pin and maintain the input common-mode voltage requirement.

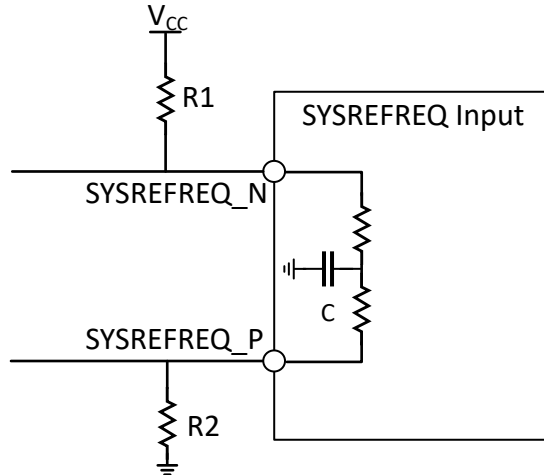

**図 6-6. SYSREFREQ Pin Logic Low Setup**

As an example, to maintain the minimum 400mV voltage difference for a VCC of 2.5V, the current draw through 100Ω is 4mA. In this example, keep the SYSREFREQ\_P pin at 1.4V DC, set the R2 to 350Ω and the R1 to 175Ω with 1.8V at SYSREFREQ\_N pin.

### 6.3.6.1 SYSREF Output Buffers

#### 6.3.6.1.1 SYSREF Output Buffers for Main Clocks (SYSREFOUT)

The SYSREF outputs within the clock output channels have the same output buffer structure as the clock output buffer, with the addition of circuitry to adjust the common-mode voltage. The SYSREF outputs are CML outputs with a common-mode voltage that can be adjusted with the SYSREFOUTx\_VCM field, and the output level that can be programmed with the SYSREFOUTx\_PWR field. This design allows DC coupling. Note that the CLKOUT outputs do not have adjustable common-mode voltage and must be AC coupled for optimal noise performance.

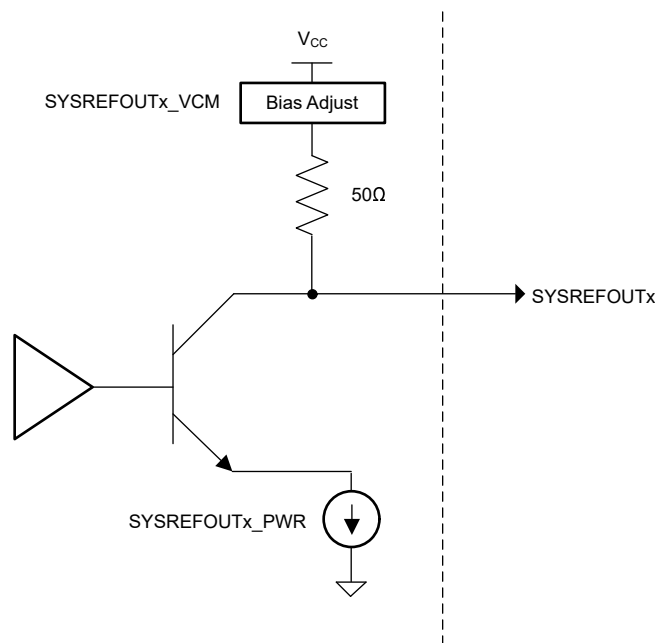

**図 6-7. SYSREF Output Buffer**

The common-mode voltage and output power are interrelated and can be simulated assuming a 100Ω differential load and no DC path to ground. The common mode voltage and output are interrelated as shown in 表 6-9. Note that for long-term reliability,  $V_{CM} - V_{OD}/2 \geq 0.5V$  is required.

表 6-9. Single-Ended Voltage ( $V_{OD}$ ) and Common-Mode Voltage ( $V_{CM}$ )

SYSREFOUT_PWR	Check: $V_{CM} - V_{OL}/2 \geq 0.5V?$	SYSREFOUT_VCM	$V_{OD}$	$V_{CM}$
0	Valid State	0	0.27	1.09
		1	0.27	1.22
		2	0.28	1.37
		3	0.28	1.54
		4	0.29	1.69
		5	0.29	1.83
		6	0.29	2.00
		7	0.29	2.16
1		0	0.32	0.79
		1	0.33	0.95
		2	0.33	1.12
		3	0.34	1.33
		4	0.35	1.51
		5	0.35	1.69
		6	0.36	1.89
		7	0.37	2.08
2	0	0.37	0.52	
	1	0.38	0.68	
	2	0.39	0.89	
	3	0.40	1.12	
	4	0.41	1.34	
	5	0.42	1.54	
	6	0.43	1.78	
	7	0.44	2.01	
3	0	0.39	0.43	
	1	0.42	0.50	
	2	0.45	0.66	
	3	0.46	0.93	
	4	0.47	1.17	
	5	0.48	1.41	
	6	0.49	1.68	
	7	0.51	1.93	
4	0	0.40	0.40	
	1	0.43	0.44	
	2	0.48	0.52	
	3	0.51	0.73	
	4	0.52	1.00	
	5	0.54	1.27	
	6	0.55	1.57	
	7	0.57	1.86	

表 6-9. Single-Ended Voltage ( $V_{OD}$ ) and Common-Mode Voltage ( $V_{CM}$ ) (続き)

SYSREFOUT_PWR	Check: $V_{CM} - V_{OL}/2 \geq 0.5V?$	SYSREFOUT_VCM	$V_{OD}$	$V_{CM}$
5	Invalid State	0	0.40	0.38
		1	0.44	0.42
		2	0.49	0.47
	Valid State	3	0.55	0.59
		4	0.58	0.85
		5	0.59	1.14
		6	0.62	1.48
6	Invalid State	7	0.63	1.79
		0	0.40	0.36
		1	0.44	0.39
		2	0.49	0.45
	Valid State	3	0.57	0.54
		4	0.63	0.70
		5	0.65	1.01
7	Invalid State	6	0.67	1.38
		7	0.70	1.73
		0	0.40	0.35
		1	0.44	0.38
	Valid State	2	0.50	0.43
		3	0.58	0.51
		4	0.66	0.62
		5	0.70	0.89
		6	0.73	1.29
		7	0.76	1.66

### 6.3.6.1.2 SYSREF Output Buffer for LOGICLK

The LOGISYSREFOUT output supports the two formats of LVDS and CML. The LOGISYSREFOUT\_EN enables the output buffer and LOGISYSREF\_FMT sets the format. LVDS mode allows programmable common mode, CML require external components, and CML allows programmable output power (see 表 6-10).

表 6-10. LOGISYSREFOUT Output Buffer Configuration

LOGISYSREFOUT_EN	LOGISYSREF_FMT	LOGISYSREF FORMAT	EXTERNAL TERMINATION REQUIRED	OUTPUT POWER	OUTPUT COMMON MODE
0	Powered Down				
1	0	LVDS	None	Fixed	Programmable with LOGISYSREF_VCM
	1	Reserved			
	2	CML	Pullup resistors 50Ω to $V_{CC}$	Controlled by LOGISYSREF_PWR	LOGISYSREF_VCM has no impact, but this changes with LOGISYSREF_PWR.
	3	Reserved			

### 6.3.6.2 SYSREF Frequency and Delay Generation

For the frequency of the SYSREF output in generator mode, the SYSREF\_DIV\_PRE divider is necessary to verify that the input of the SYSREF\_DIV divider is not more than 3.2GHz.



表 6-11. SYSREF\_DIV\_PRE Setup

f <sub>CLKIN</sub>	SYSREF_DIV_PRE	TOTAL SYSREF DIVIDE RANGE
3.2GHz or Less	+1, 2, or 4	+2, 3, 4, ...16380
3.2GHz < f <sub>CLKIN</sub> ≤ 6.4GHz	+2 or 4	+4, 6, 8, ... 16380
f <sub>CLKIN</sub> > 6.4GHz	+4	+8, 12, 16, ... 16380

For the delay, the input clock frequency is divided by SYSREF\_DLY\_DIV to generate f<sub>INTERPOLATOR</sub>. This has a restricted range as shown in 表 6-12. Note also that when SYSREF\_DLY\_BYP = 0 or 2 (delaygen engaged for generator mode), and SYSREF\_MODE = 0 or 1 (a generator mode) the SYSREF output frequency must be a multiple of the phase interpolator frequency.

$$f_{\text{INTERPOLATOR}} \% f_{\text{SYSREF}} = 0.$$

表 6-12. SYSREF Delay Setup

f <sub>CLKIN</sub>	SYSREF_DLY_DIV	SYSREFx_DLY_SCALE	f <sub>INTERPOLATOR</sub>
6.4GHz < f <sub>CLKIN</sub> ≤ 12.8GHz	16	0	0.4GHz to 0.8GHz
3.2GHz < f <sub>CLKIN</sub> ≤ 6.4GHz	8	0	0.4GHz to 0.8GHz
1.6GHz < f <sub>CLKIN</sub> ≤ 3.2GHz	4	0	0.4GHz to 0.8GHz
0.8GHz < f <sub>CLKIN</sub> ≤ 1.6GHz	2	0	0.4GHz to 0.8GHz
0.4GHz < f <sub>CLKIN</sub> ≤ 0.8GHz	2	1	0.2GHz to 0.4GHz
0.3GHz < f <sub>CLKIN</sub> ≤ 0.4GHz	2	2	0.15GHz to 0.2GHz

The maximum delay is equal to the phase interpolator period and there are  $4 \times 127 = 508$  different delay steps. Use 式 2 to calculate the size of each step.

$$\text{DelayStepSize} = 1 / (f_{\text{INTERPOLATOR}} \times 508) = \text{SYSREF\_DLY\_DIV} / (f_{\text{CLKIN}} \times 508) \quad (2)$$

Use 式 3 to calculate the total delay.

$$\text{TotalDelay} = \text{DelayStepSize} \times \text{StepNumber} \quad (3)$$

表 6-13 shows the number of steps for each delay.

表 6-13. Calculation of StepNumber

SYSREFx_DLY_PHASE	STEPNUMBER
3	127 - SYSREFx_DLY_I
2	254 - SYSREFx_DLY_Q
0	381 - SYSREFx_DLY_I
1	508 - SYSREFx_DLY_Q

The SYSREF\_DLY\_BYP field selects the delay path in SYSREF generation output and or the repeater mode bypass signal. When SYSREF\_MODE is set to continuous or pulser mode, TI recommends to set SYSREF\_DLY\_BYP to generator mode. If SYSREF\_MODE is set to repeater mode, TI recommends to set SYSREF\_DLY\_BYP to bypass mode.

### 6.3.6.3 SYSREFREQ Pins and SYSREFREQ\_FORCE Field

The SYSREFREQ pins are multipurpose and can be used for SYNC, SYSREF requests, and SYSREF windowing. These pins can be DC or AC coupled and have individual 50Ω, single-ended termination with programmable common-mode support.

In addition to these pins, the SYSREFREQ\_FORCE field can be set to 1 to emulate the same effect as forcing these pins high, simplifying hardware in some cases.

### 6.3.6.3.1 SYSREFREQ Pins Common-Mode Voltage

The SYSREFREQ\_P and SYSREFREQ\_N pins can be driven either AC or DC coupled. When driven AC coupled, the common-mode voltage can be adjusted with the SYSREFREQ\_VCM bit.

**表 6-14. SYSREFREQ Pin Common-Mode Voltage**

SYSREFREQ_VCM	COMMON-MODE VOLTAGE
0	1.3V AC-coupled
1	1.1V AC-coupled
2	1.5V AC-coupled
3	No Bias (DC Coupled)

### 6.3.6.3.2 SYSREFREQ Windowing Feature

Use SYSREF windowing to internally calibrate the timing between the SYSREFREQ and CLKIN pins to optimize the setup and hold timing. SYSREF windowing can also trim out any mismatches between SYSREFREQ and CLKIN path. This feature requires that the timing from the SYSREFREQ rising edge to the CLKIN rising edge is consistent. The timing from the SYSREFREQ rising edge to the CLKIN rising edges can be tracked with the rb\_CLKPOS field. Once the timing to the rising edge of the CLKIN pin is found, the SYSREFREQ rising edge can be internally adjusted with the SYSREFREQ\_DLY and SYSREF\_DLY\_STEP fields to optimize setup and hold timing.

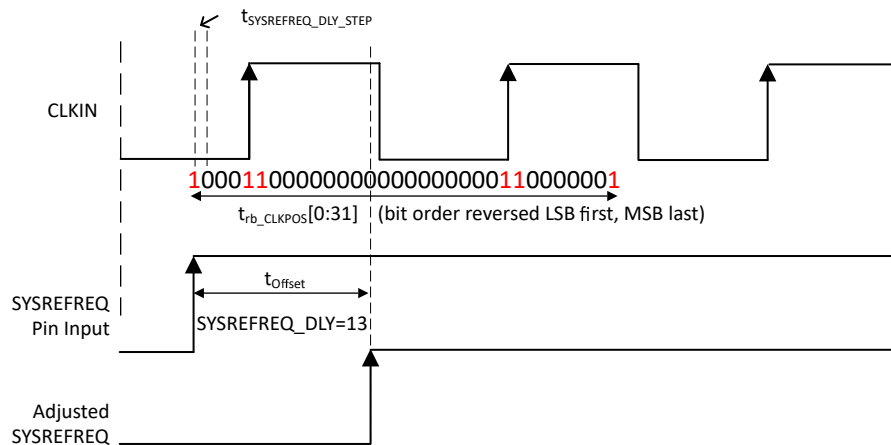

**図 6-8. SYSREFREQ Internal Timing Adjustment**

6.3.6.3.2.1 General Procedure Flowchart for SYSREF Windowing Operation



図 6-9. Flowchart for SYSREF Windowing Operation

表 6-15. SYSREFREQ\_DLY\_STEP

INPUT FREQUENCY	RECOMMENDED SYSREFREQ_DLY_STEP	DELAY(ps)
1.4GHz < f <sub>CLKIN</sub> ≤ 2.7GHz	0	22.25
2.4GHz < f <sub>CLKIN</sub> ≤ 4.7GHz	1	13
3.1GHz < f <sub>CLKIN</sub> ≤ 5.7GHz	2	10.5
f <sub>CLKIN</sub> ≥ 4.5GHz	3	7.75

6.3.6.3.2.2 SYSREFREQ Repeater Mode With Delay Generation (Retime)

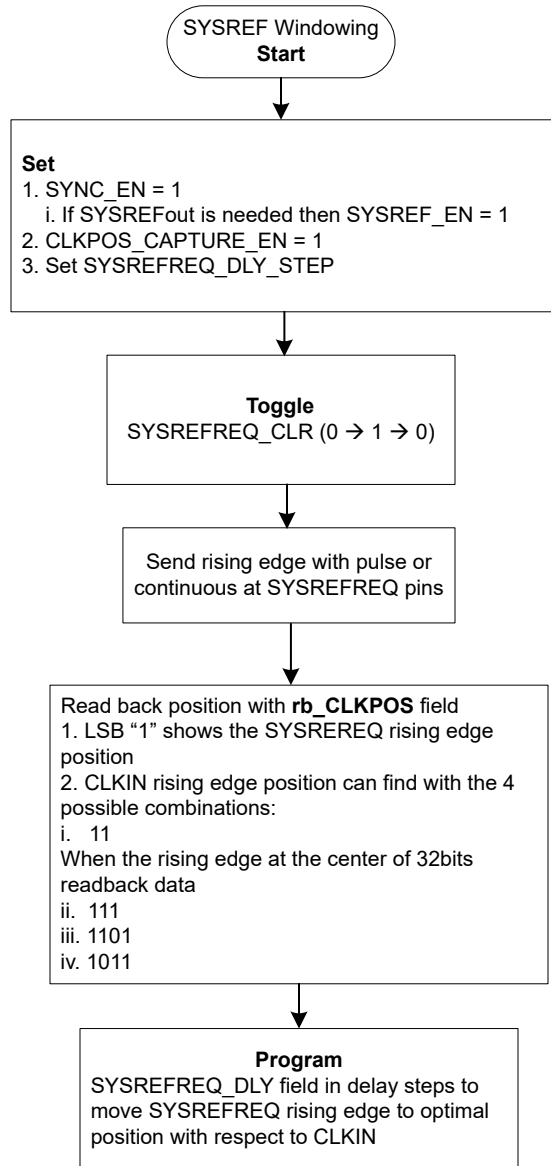
SYSREF repeater mode with delay enabled is possible with LMX to LMX fanout devices by retiming the SYSREFout at different edge of IQ generation. This retiming can have the delay margin between CLKIN and SYSREFREQ inputs based on SYSREF\_DLY\_DIV value.

表 6-16 shows how the total delay margin for the SYSREF windowing relates the various SYSREF settings.

**表 6-16. SYSREF Phase Adjust Settings for Retime in Repeater Mode**

SYSREF_DLY_DIV	POSITION CODE SELECTED DURING SYNC	EDGE FOR MAX MARGIN	TOTAL MARGIN IN CLKIN CYCLE	SYSREFx_DLY_PHASE	SYSREFx_DLY_Q	SYSREFx_DLY_I
/2	Before 1 <sup>st</sup> edge	I	-1, +1	"11"	0	127
	After 1 <sup>st</sup> edge	Qz	-1, +1	"01"	127	0
	After 2 <sup>nd</sup> edge	Iz	-1, +1	"00"	0	127
/4	Before 1 <sup>st</sup> edge	Qz	-2, +2	"01"	127	0
	After 1 <sup>st</sup> edge	Iz	-2, +2	"00"	0	127
	After 2 <sup>nd</sup> edge	Q	-2, +2	"10"	127	0
/8	Before 1 <sup>st</sup> edge	Qz	-5, +3	"01"	127	0
	After 1 <sup>st</sup> edge	Qz	-4, +4	"01"	127	0
	After 2 <sup>nd</sup> edge	Qz	-3, +5	"01"	127	0
/16	Before 1 <sup>st</sup> edge	I	-9, +7	"11"	0	127
	After 1 <sup>st</sup> edge	I	-8, +8	"11"	0	127
	After 2 <sup>nd</sup> edge	I	-7, +9	"11"	0	127

Repeater retime mode is required to perform the SYSREF windowing in the initial phase to synchronize the SYSREF\_DLY\_DIV in multiple devices. The user can later choose the SYSREFx\_DLY\_PHASE, SYSREF\_DLY\_Q and SYSREFx\_DLY\_I settings for the selected edge for the SYNC.

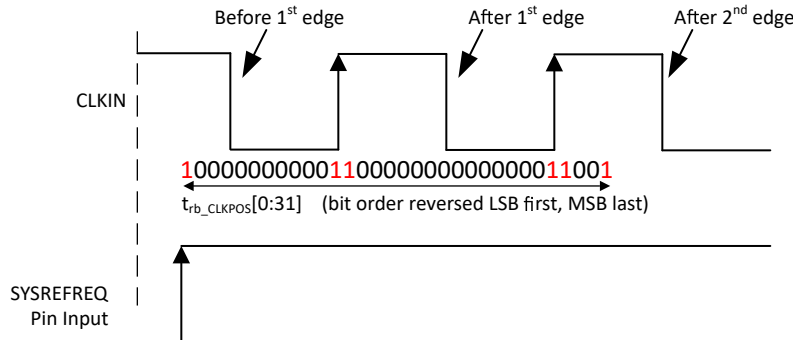

**図 6-10. SYSREF Windowing to Select the Edge Position for SYNC**

This configuration must set the device in **SYSREF\_MODE** R17[1:0] value "2" (Repeater mode) and **SYSREF\_DLY\_BPY** R72[1:0] value "2" (Delay gen engaged in all modes).

### 6.3.6.3.2.3 Other Guidance For SYSREF Windowing

- The SYSREFREQ pins must be held high for a minimum time of  $3/f_{CLKIN} + 1.6ns$  and only after this time `rb_CLKPOS` field is valid.
- If the user infers multiple valid SYSREFREQ\_DLY values from `rb_CLKPOS` registers to avoid setup and hold time violations. TI recommends to choose the lowest valid SYSREFREQ\_DLY to minimize variation over temperature.
- The programmed SYSREFREQ\_DLY for optimized setup and hold time after SYSREF windowing adjusts the internal SYSREFREQ, but the SYSREFREQ\_DLY does not show the movement in SYSREF windowing readback code. SYSREF windowing always evaluates the signals at the pins.

#### 6.3.6.3.2.4 For Glitch-Free Output

- Keep the same state for the SYSREFREQ pin when switching from request mode to windowing mode and back to request mode. For example, if the SYSREFREQ pin is high (or low) when windowing mode starts, make sure the pin state is high (or low) again after windowing mode ends before programming CLKPOS\_CAPTURE\_EN.
- The SYSREFREQ pin must be set low when switching from or to SYNC mode.

#### 6.3.6.3.2.5 If Using SYNC Feature

- Only one SYSREFREQ pin rising edge is permitted per 75 input clock cycles
- SYSREFREQ has to stay high for more than 6 clock cycles

#### 6.3.6.3.3 SYNC Feature

The SYNC feature allows the user to synchronize the CLK\_DIV, LOGICLK\_DIV, LOGICLK\_DIV\_PRE, SYSREF\_DIV, SYSREF\_DIV\_PRE, and SYSREF\_DLY\_DIV dividers so that the phase offset can be made consistent between power cycles. This allows users to synchronize multiple devices. This synchronization dividers can only be done through the SYSREFREQ pin, not the software.

### 6.3.7 Pin Mode Control

Device supports pin mode that can be used to program the device mode selection, divider and multiplier value selection, output power control, and channel output control (ON/OFF). The state machine (SM) clock must be enabled to take any logic state changed at the pin during pin mode operation.

#### 6.3.7.1 Chip Enable (CE)

The chip enable pin is used to enable and disable the device. The chip enable can be controlled through SPI, when CE pin is high (1).

**表 6-17. Chip Enable Control**

CE LOGIC	DEVICE STATUS	SPI OVERRIDE CONTROL
0	Disable	No
1	Enable	Yes

#### 6.3.7.2 Output Channel Control

Each channel outputs control through the CLKx\_EN pin. This pin enables or disable the CLKOUT and SYSREFOUT of particular channel outputs.

**表 6-18. Output Channel Control Selection**

CLKx_EN	CHANNEL OUTPUT STATE	SPI OVERRIDE CONTROL
0	Disable channel output	No
1	Enable channel output	Yes

#### 6.3.7.3 Logic Output Control

The logic output pin can enable and disable the logic clock and logic SYSREF outputs.

**表 6-19. Logic Output Enable**

LOGIC_EN	LOGIC OUTPUT STATE	SPI OVERRIDE CONTROL
0	Disable logic output	No
1	Enable logic output	Yes

#### 6.3.7.4 SYSREF Output Control

The SYSREF\_EN pin can enable and disable the SYSREF section.

**表 6-20. SYSREF Circuitry Enable**

SYSREF_EN	SYSREF CIRCUITRY	SPI OVERRIDE CONTROL
0	Disable	No
1	Enable	Yes

### 6.3.7.5 Device Mode Selection

The device functions like buffer mode, divider mode or multiplier mode are selected by the MUXSELx pin setting.

**表 6-21. Device Operating Mode Selection**

MUXSEL1	MUXSEL0	MODE SELECTION
0	0	SPI control
0	1	Buffer mode
1	0	Divider mode
1	1	Multiplier mode

### 6.3.7.6 Divider or Multiplier Value Selection

After the operating mode (divider mode or multiplier mode) is selected by MUXSELx pin logic, the divider values or multiplier values are selected by DIVSELx pin logic.

**表 6-22. Divider or Multiplier Value Selection**

DIVSEL2	DIVSEL1	DIVSEL0	DIVIDER VALUE	MULTIPLIER VALUE
0	0	0	SPI control	SPI control
0	0	1	2	x
0	1	0	3	2
0	1	1	4	3
1	0	0	5	4
1	0	1	6	x
1	1	0	7	x
1	1	1	8	x

### 6.3.7.7 Calibration Control Pin

While operating in multiplier mode, the PLL based multiplier required the calibration for frequency lock and the CAL pin transition from low to high initiates the calibration.

**表 6-23. CAL Pin Logic**

CAL	CALIBRATION STATE
0	SPI controlled calibration
0 → 1	Initiate calibration

### 6.3.7.8 Output Power Control

The output power of the all channels control through PWRSELx pins.

**表 6-24. Channel Output Power Control**

PWRSEL2	PWRSEL1	PWRSEL0	OUTPUT POWER
0	0	0	SPI Control
0	0	1	Lowest output power

表 6-24. Channel Output Power Control (続き)

PWRSEL2	PWRSEL1	PWRSEL0	OUTPUT POWER
0	1	0	-
0	1	1	-
1	0	0	-
1	0	1	-
1	1	0	-
1	1	1	Highest output power

## 7 Application and Implementation

### 注

以下のアプリケーション情報は、TI の製品仕様に含まれるものではなく、TI ではその正確性または完全性を保証いたしません。個々の目的に対する製品の適合性については、お客様の責任で判断していただくこととなります。お客様は自身の設計実装を検証しテストすることで、システムの機能を確認する必要があります。

## 7.1 Application Information

### 7.1.1 SYSREFREQ Input Configuration

The SYSREFREQ pins support single-ended or differential input in AC or DC coupling mode. The SYSREFREQ pins have an internal  $50\Omega$  termination with capacitive ground, which acts as  $100\Omega$  differential.

図 7-1 shows the generic SYSREFREQ input circuit recommendation to support all AC/DC, single-ended or differential inputs. Some of the discrete components in 図 7-1 are just placeholder for individual input signal (single-ended or differential input) and AC or DC coupled input.



図 7-1. SYSREFREQ Input Circuit Recommendations

The following figures show the individual circuit diagram for each configurations:



図 7-2. AC-Coupled Differential Input

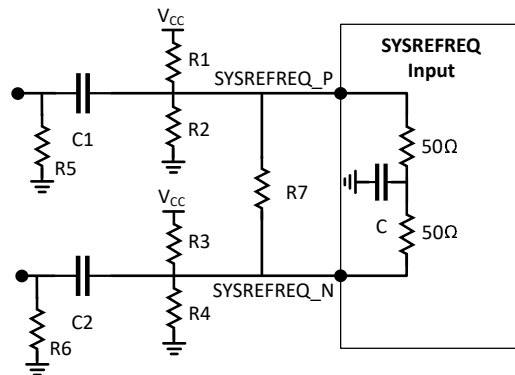

図 7-3. AC-Coupled, Single-Ended Input

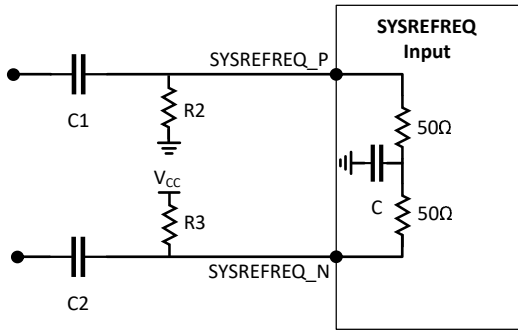

図 7-4. DC-Coupled Differential Input

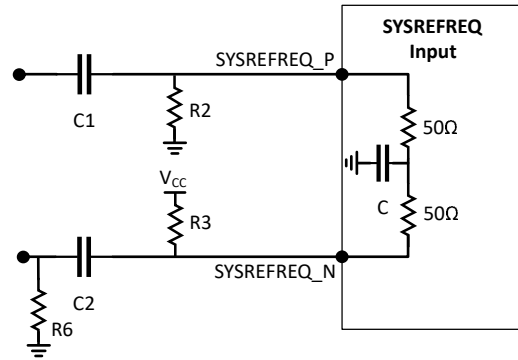

図 7-5. DC-Coupled, Single-Ended Input

1. AC coupled differential and single-ended input configurations required the resistor terminations (R2 and R3) to create the VCM at each pin and resistor values must select to maintain greater than 150mV potential difference between pin P and pin N.
  - a. As an example, to create the VCM of 1.5V at pin P and 1.65V at pin N, with the 2.5V VCC, set R3 = 550Ω and R2 = 1kΩ
  - b. For single-ended input configuration, place R6 = 50Ω to avoid any reflection at complementary input pin.
2. DC coupled differential and single-ended input configuration required to have the source common-mode voltage matched with the device input common mode specifications.
  - a. For single-ended input configuration, keep the R1, R2, R3 and R4 resistors. This method creates the same common-mode voltage at both pins, and the resistive dividers create 75Ω at pin P and 50Ω Thevenin's equivalent at pin N.
  - b. As an example, to have the common-mode voltage of 1.35V at each pin, set the resistive divider components values to R1 = 130Ω, R2 = 165Ω, R3 = 86.6Ω and R4 = 110Ω with the 2.5V VCC.

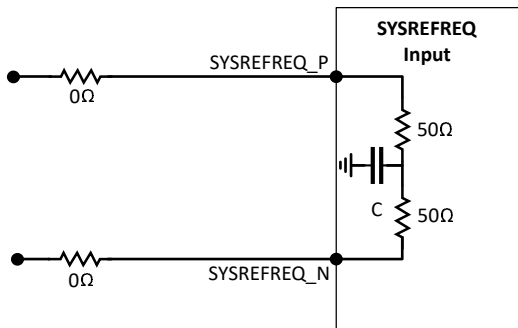
### 7.1.2 Treatment of Unused Pins

In many cases, not all pins are used. 表 7-1 lists the recommendation on how to handle these unused pins.

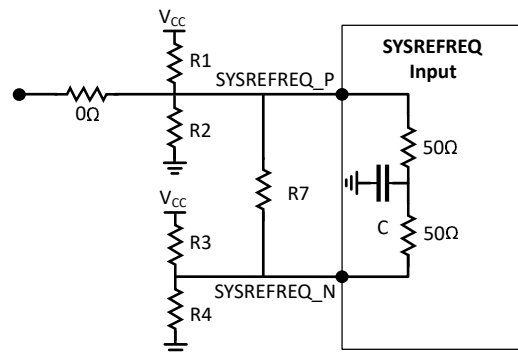
表 7-1. Treatment of Unused or Partially Used Pins

PIN(S)	TREATMENT
All VCC Pins	These pins must always be connected to the power supply. If the block that powers by these VCC pins (as implied by the pin name) is not used, then the bypassing can be minimized or eliminated.
SYSREFREQ	<ol style="list-style-type: none"> <li>1. If driving single-ended input, the complementary input pin terminates based on <a href="#">セクション 7.1.1</a>.</li> <li>2. If the SYSREFREQ pins are unused, tie the pins to the VCC with a 1kΩ resistor.</li> </ol>
CLKIN Complementary Input	If driving single-ended input, the complementary pin terminate with 50Ω resistor AC-coupled to ground.
VBIAS01 and VBIAS23	If multiplier is not used, connect these pins capacitor (1μF) to ground.



表 7-1. Treatment of Unused or Partially Used Pins (続き)

PIN(S)	TREATMENT
CLKOUT SYSREFOUT LOGICLKOUT LOGISYSREFOUT	If not used, connect a AC-coupling capacitor and 50Ω to ground.
CE, CLK <sub>x</sub> _EN, LOGIC_EN, SYSREF_EN	1. If operating device in SPI controlled mode, these pins must tied to VCC with 1kΩ resistor. 2. If not operating in both SPI and pin mode, these pins must connect to ground with 1kΩ resistor.
CAL, MUXSEL <sub>x</sub> , DIVSEL <sub>x</sub> , PWRSEL <sub>x</sub>	1. If these pins are unused, connect these pins to ground with a 1kΩ resistor.

### 7.1.3 Current Consumption

The current consumption varies as a function of the setup condition. By adding up all the block currents shown in 表 7-2, users can obtain reasonable estimate of the current for any setup condition.

表 7-2. Current Consumption per Block

BLOCK	CONDITIONS	CURRENT (mA)		
Device Core	CLK_MUX = Buffer Mode	294		
	CLK_MUX = Divide Mode	260		
	CLK_MUX = Multiply Mode	SMCLK_EN=0	540	
		SMCLK_EN=1	560	
SYSREF SYNC Windowing	Core	SYSREF_EN=1	80	
	Delay Generator	Generator Mode (SYSREF_MODE=0,1)	53	
		Repeater Mode (SYSREF_MODE=2)	40	
	Windowing Circuitry	Windowing Circuitry (CLKPOS_CAPTURE_EN=1)	SYSREF_MODE=0,1	113
			SYSREF_MODE=2	0
SYSREF Pulser	SYSREF_MODE=1	7		
CLKOUT (Per active clock channel)	Core	SYSREF_EN=0	25	
		SYSREF_EN = 1	Delay Not Used	30
			Delay Used	40
	Output Buffer	CH <sub>x</sub> _EN = CLKOUT <sub>x</sub> _EN=1	4+6*CLKOUT <sub>x</sub> _PWR	
SYSREFOUT	Core	SYSREFOUT_EN = CH <sub>x</sub> _EN = 1	74 + SYSREFOUT <sub>x</sub> _PWR*5	
	Output Buffer	SYSREFOUT_EN = CH <sub>x</sub> _EN = 1 (SYSREFOUT <sub>x</sub> _PWR and SYSREFOUT <sub>x</sub> _VCM can interact which makes the output buffer current lower than the formula predicts in some cases)	2*SYSREFOUT <sub>x</sub> _PWR + 2*SYSREFOUT <sub>x</sub> _VCM	
LOGICLKOUT	Core	LOGIC_EN=1 LOGICLKOUT_EN=1	SYSREF_EN=0	49
			SYSREF_EN=1	59
	Output Buffer	LOGIC_EN=1 LOGICLKOUT_EN=1	CML(R <sub>p</sub> =50Ω)	16+1*LOGICLKOUT_PWR
			LVDS	12
LOGISYSREFOUT	Core	LOGIC_EN=1 LOGISYSREFOUT_EN=1	SYSREF_EN=0	0
			SYSREF_EN=1	55
	Output Buffer	LOGIC_EN=1 LOGISYSREFOUT_EN=1	CML(R <sub>p</sub> =50Ω)	16+1*LOGICLKOUT_PWR
			LVDS	12

## 7.2 Typical Applications

### 7.2.1 Local Oscillator Distribution Application

For this application, the additive noise impact of using the LMX1860-SEP as a x2 multiplier is exported when added to the LMX2694-SEP 3GHz output clock. This particular setup used a single-ended clock to drive the LMX1860-SEP for the sake of simplicity of hooking up two EVMs together, but driving the device differentially is generally recommended.

図 7-6. Typical Application Schematic



図 7-7. Typical Application Schematic

#### 7.2.1.1 Design Requirements

表 7-3 shows the design parameters for this example.

If not all outputs or SYSREF are used, TI recommends to compress the layout to minimize trace lengths, especially that of the input trace.

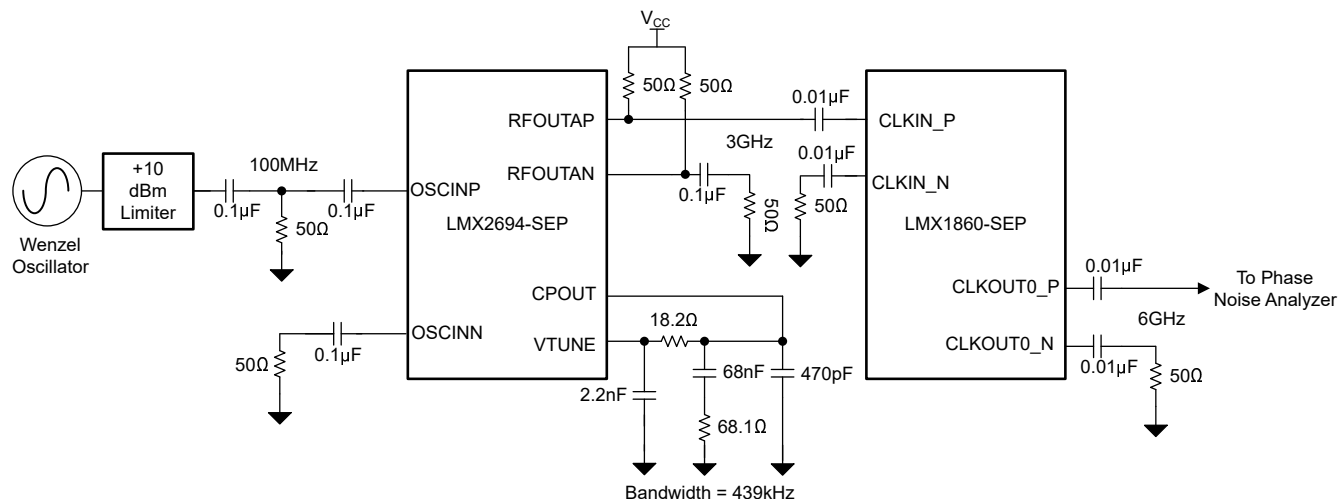
表 7-3. Design Parameters

PARAMETERS	VALUE
LMX2694-SEP Input Frequency	100MHz
LMX2694-SEP Output Frequency	3GHz
LMX1860-SEP Clock Input Frequency	3GHz
LMX1860-SEP Clock Output Frequency	6GHz
LMX1860-SEP Multiplier Value	x2

#### 7.2.1.2 Detailed Design Procedure

In this example, a 3GHz input clock is being multiplied up to a 6GHz input clock. The external components do not change that much based on internal configuration. The TICS Pro software is very useful in calculating the necessary register values and configuring the device.

The screenshot displays the TICS Pro configuration window for the LMX1860-SEP. The interface is divided into several functional areas:

- CLKIN:** Shows an input frequency of 3000.0 MHz and a multiplier of 3. The output is 11.71875 MHz.
- MULTIPLIER:** Configured with a multiplier of 3 and a 2x output stage.
- PIN MODES:** Includes settings for SYSREF\_EN, LOGIC\_EN, and various clock outputs (CLK0\_EN to CLK3\_EN).
- SYSREF:** Shows a global delay of 1.4 ns and individual channel delays for SYSREF0 to SYSREF3.
- SYSREF Frequency Generator:** Configured with a 10.0 MHz input, a 4x divider, and a 320x multiplier, resulting in a 2.34375 MHz output.
- Output Channels:** Four channels (CH0\_EN to CH3\_EN) are shown, each with a 6000.0 MHz output and a 145.71 ps delay.
- Logic and Dividers:** Includes a PRE-DIVIDER and LOGIC\_DIVIDER section with a 30.71 ps delay.

図 7-8. LMX1860-SEP TICS Pro Setup

### 7.2.1.3 Application Plot

LMX1860-SEP Multiplier Output the total plot is the sum of the noise of the LMX1860-SEP multiplier noise and the LMX2615-SP 3GHz output (scaled to 6GHz by adding 6dB). Note that the LMX1860-SEP does increase the phase noise in the 1MHz to 20MHz range, but beyond 20MHz, the input multiplier actually filters the output noise floor.

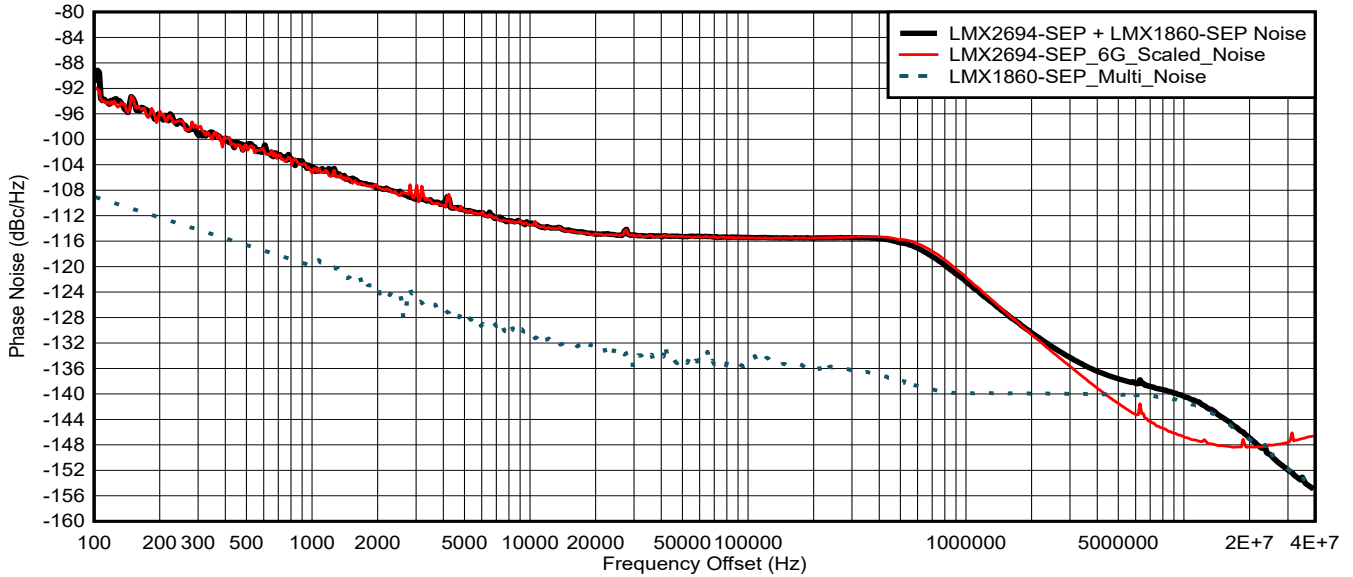

☒ 7-9. LMX1860-SEP Multiplier Output

### 7.2.2 JESD204B/C Clock Distribution Application

This application shows the JESD204B/C clock distribution circuit using the LMX1860-SEP, which can take the high frequency input from LMX2694-SEP and generate 4 pairs of JESD clocks to data converters along with clocks for FPGA.

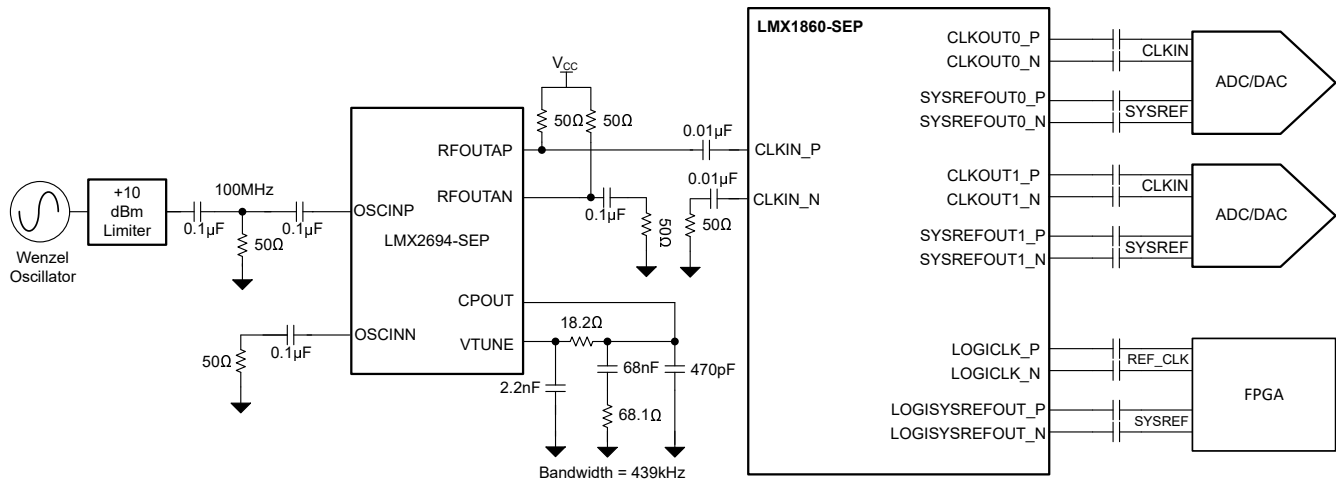

☒ 7-10. Typical JESD Clocks Block Diagram

## 7.3 Layout

### 7.3.1 Layout Guidelines

- If using a single-ended output, terminate the complementary side with 50Ω so that the impedance for the signal output is same as complementary pin side.
- GND pins on the outer perimeter of the package can be routed on the package back to the DAP.
- Minimize the length of the CLKIN trace for optimal phase noise. Poor matching can degrade the noise floor.
- Verify that the DAP on the device is well-grounded with many vias.
- Use a low loss dielectric material, such as Rogers 4003C, for optimal output power.

- Be aware that if all the outputs and SYSREF are operating, the current consumption can be high enough to exceed the recommended internal junction temperature of 125°C; a heat sink can be necessary.

### 7.3.2 Layout Example

#### Layout Example

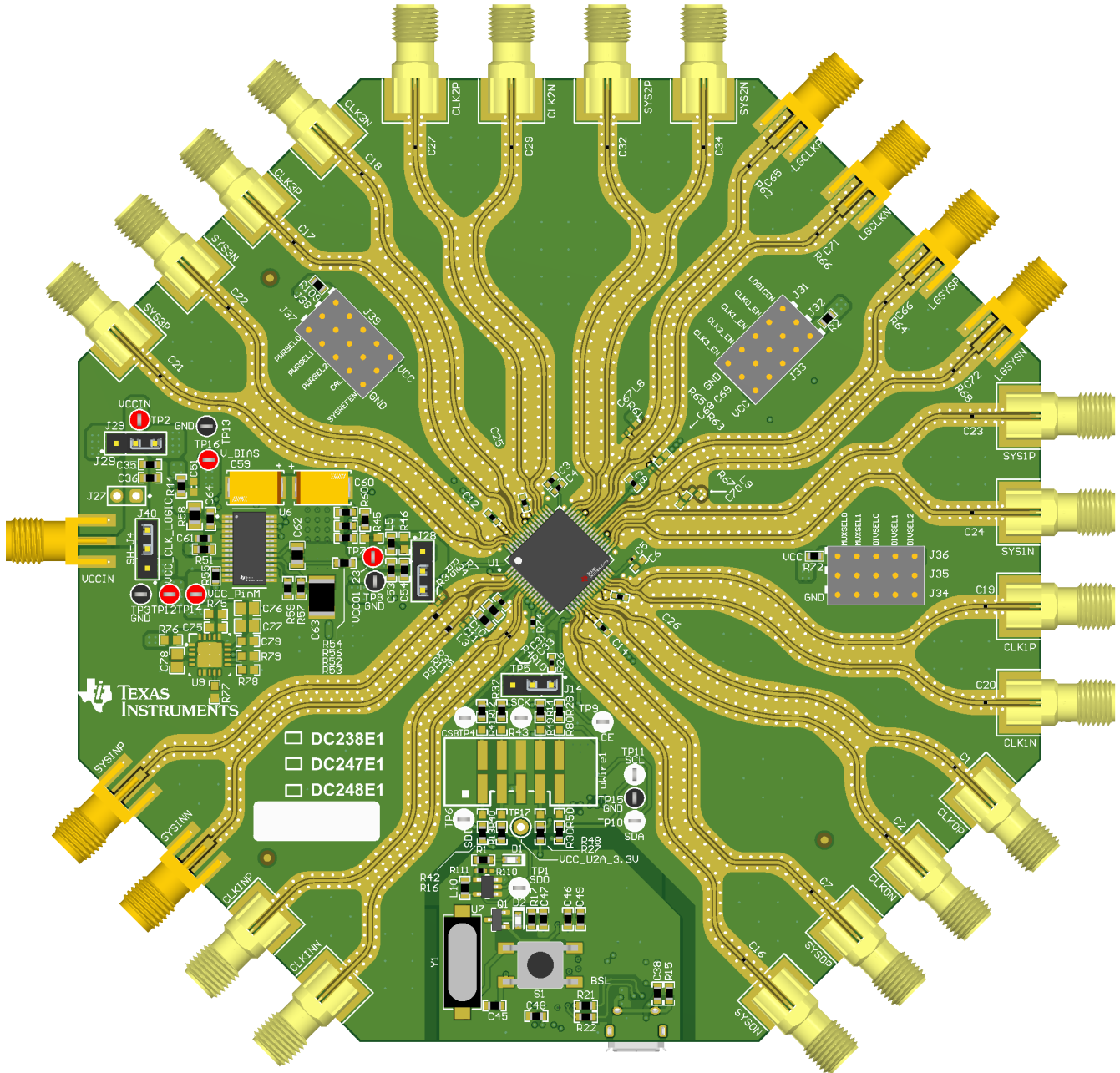

### 7.4 Power Supply Recommendations

This device uses a 2.5V supply for the whole device. A direct connection to a switching power supply can result in unwanted spurs at the output. Bypassing can be done individually at all the power pins. TI recommends placing smaller capacitors with higher frequency of minimum impedance on the same layer as the device, as close to the pins as possible. Since the frequencies of nearly all signals in the device are 100MHz or greater, therefore larger value bypass capacitors with low frequency of minimum impedance are only used for internal

LDO stability, and the distance to the device (and the loop inductance of the bypass path) can be larger. Isolate the supply pins for the clocks and the LOGICLK with a small resistor or ferrite bead if both are being used simultaneously. See the *Pin Configuration and Functions* section for additional recommendations for each pin.

注

**This device has minimal PSRR due to the low operating voltage and internal filtering by LDOs. Connecting this device to a low noise supply that does not have excessive spurious noise is important.**

#### 7.4.1 Power-Up Timing

To power up the device, some power sequencing is required.

1. Apply power to the device and verify that the VCC pins reach proper levels.
2. Although the power-on reset happens automatically, the user can do a software reset by toggling the RESET bit from 1 to 0. Verify that the time between programming these two commands is at least 1  $\mu$ s.
3. Program the registers as desired.



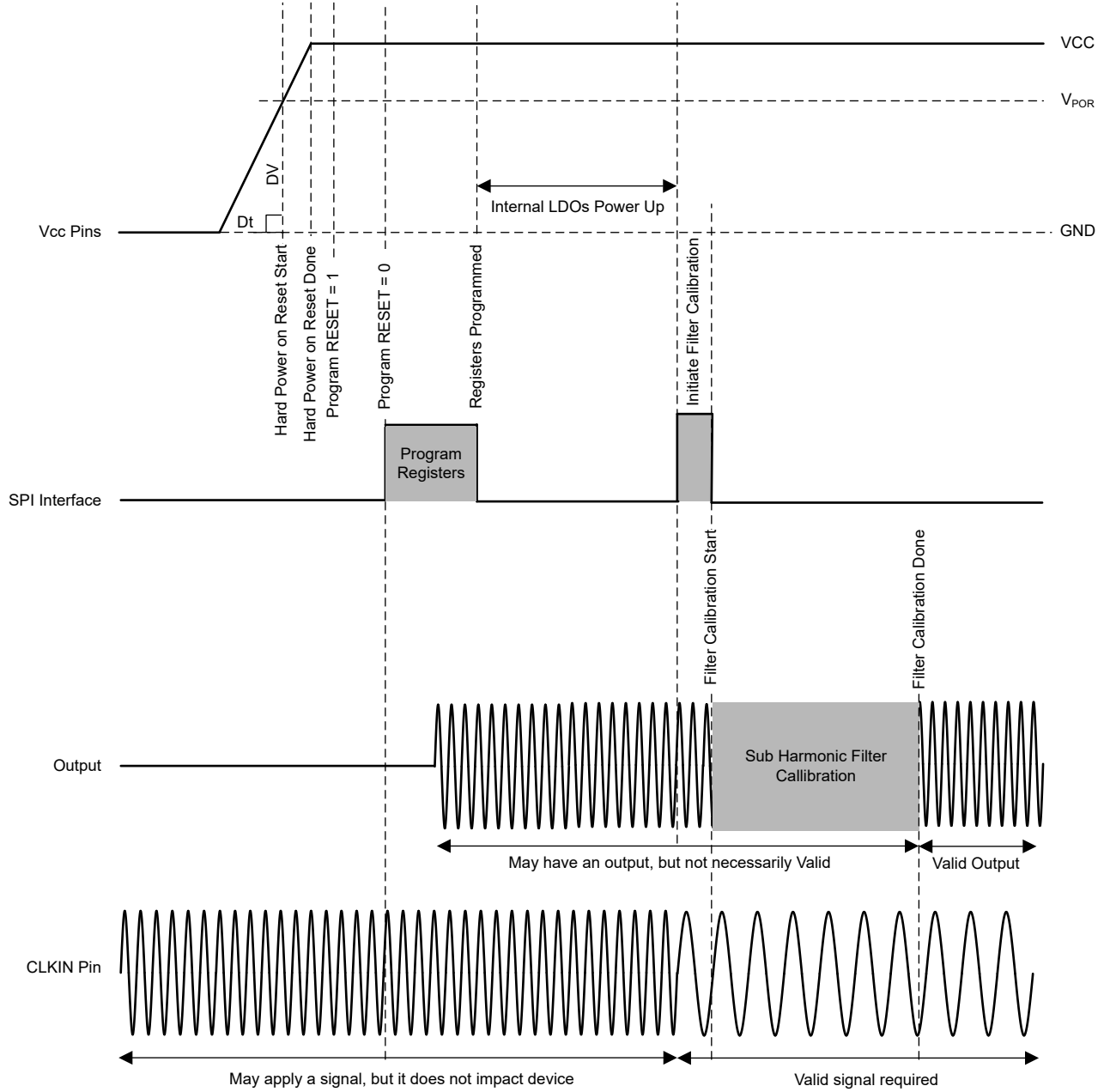

7-11. Power-Up Timing

## 7.5 Register Map

	D15	D14	D13	D12	D11	D10	D9	D8	D7	D6	D5	D4	D3	D2	D1	D0	
R0	0	0	0	0	0	0	0	0	0	0	0	0	0	POWERDOWN	0	RESET	
R2	0	0	0	0	0	0	SMCLK_DIV_PRE				SMCLK_EN	0	0	0	1	1	
R3	CH3_EN	CH2_EN	CH1_EN	CH0_EN	LOGICLK_MUTE_CALE	CH3_MUTE_CALE	CH2_MUTE_CALE	CH1_MUTE_CALE	CH0_MUTE_CALE	0	0	0	0	SMCLK_DIV			
R4	0	0	CLKOUT1_PWR			CLKOUT0_PWR			SYSREFOUT3_EN	SYSREFOUT2_EN	SYSREFOUT1_EN	SYSREFOUT0_EN	CLKOUT3_EN	CLKOUT2_EN	CLKOUT1_EN	CLKOUT0_EN	
R5	0	SYSREFOUT2_PWR			SYSREFOUT1_PWR			SYSREFOUT0_PWR			CLKOUT3_PWR			CLKOUT2_PWR			
R6	LOGICLKOUT_EN	SYSREFOUT3_VCM			SYSREFOUT2_VCM			SYSREFOUT1_VCM			SYSREFOUT0_VCM			SYSREFOUT3_PWR			
R7	0	LOGISYSREFOUT_VCM		LOGICLKOUT_VCM		LOGISYSREF_DIV_PWR_PRE		LOGICLK_DIV_PWR_PRE		LOGISYSREFOUT_PWR			LOGICLKOUT_PWR			LOGISYSREFOUT_EN	
R8	0	0	0	0	0	0	0	LOGICLK_DIV_PRE		LOGICLK_EN	0	LOGISYSREFOUT_FMT		LOGICLKOUT_FMT			
R9	SYSREFREQ_VCM		SYNC_EN	LOGICLK_DIV_PD	LOGICLK_DIV_BYP	0	LOGICLK_DIV										
R11	rb_CLKPOS																
R12	rb_CLKPOS[31:16]																
R13	0	0	0	0	0	0	0	0	0	0	0	0	0	0	SYSREFREQ_DLY_STEP		
R14	0	0	0	0	0	0	0	SYNC_MUTE_PD	0	0	0	0	0	CLKPOSS_CAPTURE_EN	SYSREFREQ_MODE	SYSREFREQ_LATCH	
R15	0	0	0	0	SYSREF_DIV_PRE		1	SYSREF_EN	0	SYSREFREQ_DLY					SYSREFREQ_CLR		
R16	SYSREF_PULSE_CNT				SYSREF_DIV												
R17	0	0	0	0	0	SYSREF0_DLY_I						SYSREF0_DLY_PHASE		SYSREF_MODE			
R18	SYSREF1_DLY_I							SYSREF1_DLY_PHASE			SYSREF0_DLY_Q						
R19	SYSREF2_DLY_I							SYSREF2_DLY_PHASE			SYSREF1_DLY_Q						
R20	SYSREF3_DLY_I							SYSREF3_DLY_PHASE			SYSREF2_DLY_Q						
R21	LOGISYSREF_DLY_I							LOGISYSREF_DLY_PHASE			SYSREF3_DLY_Q						
R22	SYSREF1_DLY_SCALE		SYSREF0_DLY_SCALE		SYSREF_DLY_DIV			0	0	LOGISYSREF_DLY_Q							
R23	TS_EN	1	MUXOUT_EN	0	0	0	0	0	0	MUXOUT_SEL	LOGISYSREF_DLY_SCALE	SYSREF3_DLY_SCALE		SYSREF2_DLY_SCALE			
R24	0	0	0	0	rb_TS											TS_CNT_EN	
R25	0	0	0	0	0	0	1	0	0	CLKDIV_RST	CLK_DIV			CLK_MUX			
R28	0	0	0	VCO_CORE_FORCE	VCO_CORE			0	0	0	0	0	1	0	0	0	
R29	0	0	0	0	0	1	0	1	VCO_CAPCTRL								



R33	0	1	0	1	0	1	1	0	0	1	1	0	0	1	1	0
R34	0	0	0	0	0	0	0	0	0	0	0	0	0	1	0	1
R65	0	1	1	0	0	1	0	rb_VCO_CORE					0	0	0	0
R67	0	1	0	1	0	0	0	1	1	1	0	0	1	0	1	1
R72	0	0	0	0	0	0	0	0	0	0	0	0	0	SYSRE FREQ_ FORCE	SYSREF_DLY_B YP	
R73	0	0	0	1	0	0	0	0	0	0	0	0	0	0	0	0
R75	rb_CLK 2_EN	rb_CLK 1_EN	rb_CLK 0_EN	rb_MU XSEL1	rb_MU XSEL0	rb_LOG IC_EN	rb_LD		rb_DIV SEL2	rb_DIV SEL1	rb_DIV SEL0	rb_CE	0	0	1	1
R76	0	0	0	0	0	0	0	0	0	0	0	0	rb_PW RSEL2	rb_PW RSEL1	rb_PW RSEL0	rb_CLK 3_EN
R79	0	0	0	0	0	0	0	0	0	0	0	0	0	1	0	1
R86	0	0	0	0	0	0	0	0	0	0	0	0	0	MUXO UT_EN _OVRD	0	0
R90	0	0	0	0	0	0	0	0	0	LOGIC LK_DIV _BYP3	LOGIC LK_DIV _BYP2	0	0	0	0	0

Registers not listed in this table must NOT be programmed as doing so can adversely impact performance or functionality of the device.

The following registers must NOT be programmed to avoid adversely impacting the performance of the device: R1, R10, R26, R27, R30-R32,

The following registers do NOT require programming if clock output multiplier is NOT used: R29, R33, R34, R65, R67, R73

The following registers do NOT require programming if LOGICLK is NOT used: R79, R90

### 7.5.1 Device Registers

表 7-4 lists the memory-mapped registers for the Device registers. All register offset addresses not listed in 表 7-4 must be considered as reserved locations and the register contents must not be modified.

**表 7-4. DEVICE Registers**

Offset	Acronym	Register Name	Section
0h	R0	Powerdown, Reset, Multiplier Mode Calibration	<a href="#">セクション 7.5.1.1</a>
2h	R2	Multiplier Mode (State Machine Clock)	<a href="#">セクション 7.5.1.2</a>
3h	R3	Multiplier Mode (State Machine Clock), Output Enables	<a href="#">セクション 7.5.1.3</a>
4h	R4	Output Enables, CLKOUT Power	<a href="#">セクション 7.5.1.4</a>
5h	R5	CLKOUT Power, SYSREFOUT Power	<a href="#">セクション 7.5.1.5</a>
6h	R6	LOGICLK Enable, SYSREFOUT Power/VCM	<a href="#">セクション 7.5.1.6</a>
7h	R7	LOGICLK and LOGISYSREF	<a href="#">セクション 7.5.1.7</a>
8h	R8	LOGICLK and LOGISYSREF	<a href="#">セクション 7.5.1.8</a>
9h	R9	LOGICLK Divider, SYNC, SYSREFREQ	<a href="#">セクション 7.5.1.9</a>
Bh	R11	SYSREFREQ Windowing (readback)	<a href="#">セクション 7.5.1.10</a>
Ch	R12	SYSREFREQ Windowing (readback)	<a href="#">セクション 7.5.1.11</a>
Dh	R13	SYSREFREQ Windowing	<a href="#">セクション 7.5.1.12</a>
Eh	R14	SYSREFREQ Windowing, SYNC, SYSREF	<a href="#">セクション 7.5.1.13</a>
Fh	R15	SYSREFREQ Windowing, SYNC, SYSREF	<a href="#">セクション 7.5.1.14</a>
10h	R16	SYSREF	<a href="#">セクション 7.5.1.15</a>
11h	R17	SYSREF, SYSREFOUT Delay	<a href="#">セクション 7.5.1.16</a>
12h	R18	SYSREFOUT Delay	<a href="#">セクション 7.5.1.17</a>
13h	R19	SYSREFOUT Delay	<a href="#">セクション 7.5.1.18</a>
14h	R20	SYSREFOUT Delay	<a href="#">セクション 7.5.1.19</a>
15h	R21	SYSREFOUT Delay	<a href="#">セクション 7.5.1.20</a>
16h	R22	SYSREFOUT Delay	<a href="#">セクション 7.5.1.21</a>
17h	R23	Temperature Sensor, MUXOUT, SYSREFOUT Delay	<a href="#">セクション 7.5.1.22</a>
18h	R24	Temperature Sensor	<a href="#">セクション 7.5.1.23</a>
19h	R25	Multiplier Mode, Divider Mode	<a href="#">セクション 7.5.1.24</a>
1Ch	R28	Multiplier Mode (optional, partial assist calibration)	<a href="#">セクション 7.5.1.25</a>
1Dh	R29	Multiplier Mode (optional, partial assist calibration)	<a href="#">セクション 7.5.1.26</a>
21h	R33	Multiplier Mode (RESERVED, must write in multiplier mode)	
22h	R34	Multiplier Mode (RESERVED, must write in multiplier mode)	
41h	R65	Multiplier Mode (read-only, optional, for partial assist calibration)	<a href="#">セクション 7.5.1.29</a>
43h	R67	Multiplier Mode (read-only, optional, for partial assist calibration)	<a href="#">セクション 7.5.1.30</a>
48h	R72	SYSREF	<a href="#">セクション 7.5.1.31</a>
49h	R73	Reserved	
4Bh	R75	Multiplier Mode (read-only, optional, lock detect)	<a href="#">セクション 7.5.1.33</a>
4Ch	R76	Read-only	<a href="#">セクション 7.5.1.34</a>
56h	R86	MUXOUT (RESERVED, optional, for tri-state)	
5Ah	R90	LOGICLK Divider (RESERVED, optional, for divider bypass)	

Complex bit access types are encoded to fit into small table cells. 表 7-5 shows the codes that are used for access types in this section.

**表 7-5. Device Access Type Codes**

Access Type	Code	Description
Read Type		
R	R	Read
Write Type		
W	W	Write
Reset or Default Value		
-n		Value after reset or the default value

### 7.5.1.1 R0 Register (Offset = 0h) [Reset = 0000h]

R0 is shown in [表 7-6](#).

Return to the [Summary Table](#).

**表 7-6. R0 Register Field Descriptions**

Bit	Field	Type	Reset	Description
15-3	UNDISCLOSED	R/W	0h	Program this field to 0x0.
2	POWERDOWN	R/W	0h	Sets the device in a low-power state. The states of other registers are maintained.
1	UNDISCLOSED	R/W	0h	Program this field to 0x0.
0	RESET	R/W	0h	Soft Reset. Resets the entire logic and registers (equivalent to power-on reset). Self-clearing on next register write.

### 7.5.1.2 R2 Register (Offset = 2h) [Reset = 0223h]

R2 is shown in [表 7-7](#).

Return to the [Summary Table](#).

**表 7-7. R2 Register Field Descriptions**

Bit	Field	Type	Reset	Description
15-11	UNDISCLOSED	R	0h	Program this field to 0x0.
10	UNDISCLOSED	R/W	0h	Program this field to 0x0.
9-6	SMCLK_DIV_PRE	R/W	8h	Pre-divider for State Machine clock (one hot divider). The state machine clock is divided from the input clock. The output of the pre-divider should be $\leq 1600\text{MHz}$ . Values other than those listed are reserved. 2h = /2 4h = /4 8h = /8
5	SMCLK_EN	R/W	1h	Enables the state machine clock generator. Only required to calibrate the multiplier, and for multiplier lock detect (including on MUXOUT pin). If the multiplier is not used, or if the multiplier lock detect feature is not used, the state machine clock generator can be disabled to minimize crosstalk.
4-0	UNDISCLOSED	R/W	3h	Program this field to 0x3.

### 7.5.1.3 R3 Register (Offset = 3h) [Reset = FF86h]

R3 is shown in [表 7-8](#).

Return to the [Summary Table](#).

**表 7-8. R3 Register Field Descriptions**

Bit	Field	Type	Reset	Description
15	CH3_EN	R/W	1h	Enables CH3 (CLKOUT3, SYSOUT3). Setting this bit to 0 will completely disable CH3, overriding the state of other powerdown/enable bits.
14	CH2_EN	R/W	1h	Enables CH2 (CLKOUT2, SYSOUT2). Setting this bit to 0 will completely disable CH2, overriding the state of other powerdown/enable bits.
13	CH1_EN	R/W	1h	Enables CH1 (CLKOUT1, SYSOUT1). Setting this bit to 0 will completely disable CH1, overriding the state of other powerdown/enable bits.
12	CH0_EN	R/W	1h	Enables CH0 (CLKOUT0, SYSOUT0). Setting this bit to 0 will completely disable CH0, overriding the state of other powerdown/enable bits.
11	LOGICLK_MUTE_CAL	R/W	1h	Mutes LOGIC outputs (LOGICLK/LOGISYS) during multiplier calibration.
10	CH3_MUTE_CAL	R/W	1h	Mutes CH3 (CLKOUT3/SYSOUT3) during multiplier calibration.
9	CH2_MUTE_CAL	R/W	1h	Mutes CH2 (CLKOUT2/SYSOUT2) during multiplier calibration.
8	CH1_MUTE_CAL	R/W	1h	Mutes CH1 (CLKOUT1/SYSOUT1) during multiplier calibration.
7	CH0_MUTE_CAL	R/W	1h	Mutes CH0 (CLKOUT0/SYSOUT0) during multiplier calibration.
6-3	UNDISCLOSED	R	0h	Program this field to 0x0.
2-0	SMCLK_DIV	R/W	6h	Sets state machine clock divider. Further divides the output of the state machine clock pre-divider. Input frequency from SMCLK_DIV_PRE must be $\leq 1600$ MHz. Output frequency must be $\leq 30$ MHz. Divide value is $2^{\text{SMCLK\_DIV}}$ . 0h = /1 1h = /2 2h = /4 3h = /8 4h = /16 5h = /32 6h = /64 7h = /128

#### 7.5.1.4 R4 Register (Offset = 4h) [Reset = 36FFh]

R4 is shown in [表 7-9](#).

Return to the [Summary Table](#).

**表 7-9. R4 Register Field Descriptions**

Bit	Field	Type	Reset	Description
15-14	UNDISCLOSED	R	0h	Program this field to 0x0.
13-11	CLKOUT1_PWR	R/W	6h	Sets the output power of CLKOUT1. Larger values correspond to higher output power.
10-8	CLKOUT0_PWR	R/W	6h	Sets the output power of CLKOUT0. Larger values correspond to higher output power.
7	SYSREFOUT3_EN	R/W	1h	Enables SYSREFOUT3 output buffer.
6	SYSREFOUT2_EN	R/W	1h	Enables SYSREFOUT2 output buffer.
5	SYSREFOUT1_EN	R/W	1h	Enables SYSREFOUT1 output buffer.
4	SYSREFOUT0_EN	R/W	1h	Enables SYSREFOUT0 output buffer.
3	CLKOUT3_EN	R/W	1h	Enables CLKOUT3 output buffer.
2	CLKOUT2_EN	R/W	1h	Enables CLKOUT2 output buffer.
1	CLKOUT1_EN	R/W	1h	Enables CLKOUT1 output buffer.

**表 7-9. R4 Register Field Descriptions (続き)**

Bit	Field	Type	Reset	Description
0	CLKOUT0_EN	R/W	1h	Enables CLKOUT0 output buffer.

### 7.5.1.5 R5 Register (Offset = 5h) [Reset = 4936h]

R5 is shown in [表 7-10](#).

Return to the [Summary Table](#).

**表 7-10. R5 Register Field Descriptions**

Bit	Field	Type	Reset	Description
15	UNDISCLOSED	R	0h	Program this field to 0x0.
14-12	SYSREFOUT2_PWR	R/W	4h	Sets the output power of SYSREFOUT2. Larger values correspond to higher output power. SYSREFOUT2_VCM must be set properly to bring the output common mode voltage within permissible limits.
11-9	SYSREFOUT1_PWR	R/W	4h	Sets the output power of SYSREFOUT1. Larger values correspond to higher output power. SYSREFOUT1_VCM must be set properly to bring the output common mode voltage within permissible limits.
8-6	SYSREFOUT0_PWR	R/W	4h	Sets the output power of SYSREFOUT0. Larger values correspond to higher output power. SYSREFOUT0_VCM must be set properly to bring the output common mode voltage within permissible limits.
5-3	CLKOUT3_PWR	R/W	6h	Sets the output power of CLKOUT3. Larger values correspond to higher output power.
2-0	CLKOUT2_PWR	R/W	6h	Sets the output power of CLKOUT2. Larger values correspond to higher output power.

### 7.5.1.6 R6 Register (Offset = 6h) [Reset = B6DCh]

R6 is shown in [表 7-11](#).

Return to the [Summary Table](#).

**表 7-11. R6 Register Field Descriptions**

Bit	Field	Type	Reset	Description
15	LOGICLKOUT_EN	R/W	1h	Enables the logic clock output buffer.
14-12	SYSREFOUT3_VCM	R/W	3h	Sets the output common mode of SYSREFOUT3. SYSREFOUT3_PWR must be set properly to bring the minimum and maximum output voltage within permissible limits.
11-9	SYSREFOUT2_VCM	R/W	3h	Sets the output common mode of SYSREFOUT2. SYSREFOUT2_PWR must be set properly to bring the minimum and maximum output voltage within permissible limits.
8-6	SYSREFOUT1_VCM	R/W	3h	Sets the output common mode of SYSREFOUT1. SYSREFOUT1_PWR must be set properly to bring the minimum and maximum output voltage within permissible limits.
5-3	SYSREFOUT0_VCM	R/W	3h	Sets the output common mode of SYSREFOUT0. SYSREFOUT0_PWR must be set properly to bring the minimum and maximum output voltage within permissible limits.
2-0	SYSREFOUT3_PWR	R/W	4h	Sets the output power of SYSREFOUT3. Larger values correspond to higher output power. SYSREFOUT3_VCM must be set properly to bring the output common mode voltage within permissible limits.

### 7.5.1.7 R7 Register (Offset = 7h) [Reset = 0001h]

R7 is shown in [表 7-12](#).

Return to the [Summary Table](#).

**表 7-12. R7 Register Field Descriptions**

Bit	Field	Type	Reset	Description
15	UNDISCLOSED	R	0h	Program this field to 0x0.
14-13	LOGISYSREFOUT_VCM	R/W	0h	In LVDS mode, sets the output common mode of the logic SYSREF output. Other output formats ignore this field. 0h = 1.2V 1h = 1.1V 2h = 1.0V 3h = 0.9V
12-11	LOGICLKOUT_VCM	R/W	0h	In LVDS mode, sets the output common mode of the logic clock output. Other output formats ignore this field. 0h = 1.2V 1h = 1.1V 2h = 1.0V 3h = 0.9V
10-9	LOGISYSREF_DIV_PWR_PRE	R/W	0h	Sets the output power of the logic SYSREF pre-driver. Larger values correspond to higher output power.
8-7	LOGICLK_DIV_PWR_PRE	R/W	0h	Sets the output power of the logic clock pre-driver. Larger values correspond to higher output power.
6-4	LOGISYSREFOUT_PWR	R/W	0h	Sets the output power of LOGISYSREFOUT for CML format only (other output formats ignore this field). Larger values correspond to higher output power.
3-1	LOGICLKOUT_PWR	R/W	0h	Sets the output power of LOGICLKOUT for CML format only (other output formats ignore this field). Larger values correspond to higher output power.
0	LOGISYSREFOUT_EN	R/W	1h	Enables the logic SYSREF output buffer.

**7.5.1.8 R8 Register (Offset = 8h) [Reset = 0120h]**

R8 is shown in [表 7-13](#).

Return to the [Summary Table](#).

**表 7-13. R8 Register Field Descriptions**

Bit	Field	Type	Reset	Description
15-9	UNDISCLOSED	R	0h	Program this field to 0x0.
8-6	LOGICLK_DIV_PRE	R/W	4h	Sets pre-divider value for logic clock divider. Output of the pre-divider must be less than or equal to 3.2 GHz. When LOGICLK_DIV_PRE=1, it is also required register R79 is programmed to a value of 0x0005 and R90 to 0x0060 (LOGICLK_DIV_BYP2=1, LOGICLK_DIV_BYP3=1). Values for LOGICLK_DIV_PRE other than those listed below are reserved. 1h = /1 2h = /2 4h = /4
5	LOGIC_EN	R/W	1h	Enables LOGICLK subsystem (LOGICLKOUT, LOGISYSREFOUT). Setting this bit to 0x0 completely disables all LOGICLKOUT and LOGISYSREFOUT circuitry, overriding the state of other powerdown/enable bits.
4	UNDISCLOSED	R/W	0h	Program this field to 0x0.
3-2	LOGISYSREFOUT_FMT	R/W	0h	Selects the output driver format of the LOGISYSREFOUT output. 0h = LVDS 1h = Reserved 2h = CML 3h = Reserved

**表 7-13. R8 Register Field Descriptions (続き)**

Bit	Field	Type	Reset	Description
1-0	LOGICLKOUT_FMT	R/W	0h	Selects the output driver format of the LOGICLKOUT output. 0h = LVDS 1h = Reserved 2h = CML 3h = Reserved

### 7.5.1.9 R9 Register (Offset = 9h) [Reset = 0020h]

R9 is shown in 表 7-14.

Return to the [Summary Table](#).

**表 7-14. R9 Register Field Descriptions**

Bit	Field	Type	Reset	Description
15-14	SYSREFREQ_VCM	R/W	0h	Sets the internal DC Bias for the SYSREFREQ pins. Bias must be enabled for AC-coupled inputs; but can be enabled and overdriven, or disabled, for DC-coupled inputs. SYSREFREQ DC pin voltage must be in the range of 0.7 V to VCC, including minimum and maximum signal swing. 0h = 1.3V 1h = 1.1V 2h = 1.5V 3h = Disabled
13	SYNC_EN	R/W	0h	Enables synchronization path for the dividers and allows the clock position capture circuitry to be enabled. Used for multi-device synchronization. Redundant if SYSREF_EN = 0x1.
12	LOGICLK_DIV_PD	R/W	0h	Disables the LOGICLK divider. LOGICLK pre-divider remains enabled. Used to reduce current consumption when bypassing the LOGICLK divider.
11	LOGICLK_DIV_BYP	R/W	0h	Bypasses the LOGICLK_DIV divider in order to derive the LOGICLK output directly from the LOGICLK_DIV_PRE divider. Should only be used when LOGICLK_DIV_PRE=1 as one of the steps to achieve a total divide of 1 for the LOGICLK. In order to achieve a divide by 1, the following steps are required. 1. Set LOGICLK_DIV_PRE=1 2. Ensure that register R79 is programmed to a value of 0x0005 3. Program R90 to 0x0060 (LOGICLK_DIV23=1, LOGICLK_DIV_DCC=1) 4. Set LOGICLK_DIV_BYP=1 When not wanting a total divide of 1 for the LOGICLK, this bit should be set to 0. 0h = Engage LOGICLK divider 1h = Bypass LOGICLK divider
10	UNDISCLOSED	R/W	0h	Program this field to 0x0.
9-0	LOGICLK_DIV	R/W	20h	Sets LOGICLK divider value. Maximum input frequency from LOGICLK_DIV_PRE must be ≤ 3200 MHz. The maximum LOGICLKOUT frequency must be ≤ 800 MHz to avoid amplitude degradation. 0h = Reserved 1h = Reserved 2h = /2 3h = /3 3FFh = /1023

### 7.5.1.10 R11 Register (Offset = Bh) [Reset = 0000h]

R11 is shown in 表 7-15.

Return to the [Summary Table](#).

**表 7-15. R11 Register Field Descriptions**

Bit	Field	Type	Reset	Description
15-0	rb_CLKPOS	R	0h	Stores a snapshot of the CLKIN signal rising edge positions relative to a SYSREFREQ rising edge, with the snapshot starting from the LSB and ending at the MSB. Each bit represents a sample of the CLKIN signal, separated by a delay determined by the SYSREFREQ_DLY_STEP field. The first and last bits of rb_CLKPOS are always set, indicating uncertainty at the capture window boundary conditions. CLKIN rising edges are represented by every sequence of two set bits from LSB to MSB, including bits at the boundary conditions. The position of the CLKIN rising edges in the snapshot, along with the CLKIN signal period and the delay step size, can be used to compute the value of SYSREFREQ_DLY which maximizes setup and hold times for SYNC signals on the SYSREFREQ pins.

#### 7.5.1.11 R12 Register (Offset = Ch) [Reset = 0000h]

R12 is shown in [表 7-16](#).

Return to the [Summary Table](#).

**表 7-16. R12 Register Field Descriptions**

Bit	Field	Type	Reset	Description
15-0	rb_CLKPOS[31:16]	R	0h	MSB of rb_CLKPOS field.

#### 7.5.1.12 R13 Register (Offset = Dh) [Reset = 0003h]

R13 is shown in [表 7-17](#).

Return to the [Summary Table](#).

**表 7-17. R13 Register Field Descriptions**

Bit	Field	Type	Reset	Description
15-2	UNDISCLOSED	R	0h	Program this field to 0x0.
1-0	SYSREFREQ_DLY_STEP	R/W	3h	Sets the step size of the delay element used in the SYSREFREQ path, both for SYSREFREQ input delay and for clock position captures. The recommended frequency range for each step size creates the maximum number of usable steps for a given CLKIN frequency. The ranges include some overlap to account for process and temperature variations. If the CLKIN frequency is covered by an overlapping span, larger delay step sizes improve the likelihood of detecting a CLKIN rising edge during a clock position capture. However, since larger values include more delay steps, larger step sizes have greater total delay variation across PVT relative to smaller step sizes. 0h = 28 ps (1.4GHz to 2.7GHz) 1h = 15 ps ( 2.4GHz to 4.7GHz) 2h = 11 ps (3.1GHz to 5.7GHz) 3h = 8 ps (4.5GHz to 12.8GHz)

#### 7.5.1.13 R14 Register (Offset = Eh) [Reset = 0002h]

R14 is shown in [表 7-18](#).

Return to the [Summary Table](#).



表 7-18. R14 Register Field Descriptions

Bit	Field	Type	Reset	Description
15-9	UNDISCLOSED	R/W	0h	Program this field to 0x0.
8	SYNC_MUTE_PD	R/W	0h	Removes the mute condition on the SYSREFOUT and LOGISYSREFOUT pins during SYNC mode (SYSREFREQ_MODE = 0x0). Since the SYNC operation also resets the SYSREF dividers, the mute condition is usually desirable, and this bit can be left at the default value.
7-3	UNDISCLOSED	R/W	0h	Program this field to 0x0.
2	CLKPOS_CAPTURE_EN	R/W	0h	Enables the windowing circuit which captures the clock position in the rb_CLKPOS registers with respect to a SYSREF edge. The windowing circuit must be cleared by toggling SYSREFREQ_CLR high then low before a clock position capture. The first rising edge on the SYSREFREQ pins after clearing the windowing circuit triggers the capture. The capture circuitry greatly increases supply current, and does not need to be enabled to delay the SYSREFREQ signal in SYNC or SYSREF modes. Once the desired value of SYSREFREQ_DLY is determined, set this bit to 0x0 to minimize current consumption. If SYNC_EN = 0 and SYSREF_EN = 0, the value of this bit is ignored, and the windowing circuit is disabled.
1	SYSREFREQ_MODE	R/W	1h	Selects the function of the SYSREFREQ pins 0h = SYNC pin 1h = SYSREFREQ pin
0	SYSREFREQ_LATCH	R/W	0h	Latches the internal SYSREFREQ state to logic high on the first rising edge of the SYSREFREQ pins. This latch can be cleared by setting SYSREFREQ_CLR=1.

#### 7.5.1.14 R15 Register (Offset = Fh) [Reset = 0B01h]

R15 is shown in 表 7-19.

Return to the [Summary Table](#).

表 7-19. R15 Register Field Descriptions

Bit	Field	Type	Reset	Description
15-12	UNDISCLOSED	R	0h	Program this field to 0x0.
11-10	SYSREF_DIV_PRE	R/W	2h	Sets the SYSREF pre-divider. Maximum output frequency must be $\leq$ 3.2GHz. 0h = /1 1h = /2 2h = /4 3h = Reserved
9	UNDISCLOSED	R/W	1h	Program this field to 0x1.
8	SYSREF_EN	R/W	1h	Enables SYSREF subsystem (and SYNC subsystem when SYSREFREQ_MODE = 0x0). Setting this bit to 0x0 completely disables all SYNC, SYSREF, and clock position capture circuitry, overriding the state of other powerdown/enable bits except SYNC_EN. If SYNC_EN = 0x1, the SYNC path and clock position capture circuitry are still enabled, regardless of the state of SYSREF_EN.
7	UNDISCLOSED	R/W	0h	Program this field to 0x0.

**表 7-19. R15 Register Field Descriptions (続き)**

Bit	Field	Type	Reset	Description
6-1	SYSREFREQ_DLY	R/W	0h	Sets the delay line step for the external SYSREFREQ signal. Each delay line step delays the SYSREFREQ signal by an amount equal to SYSREFREQ_DELAY_STEP x SYSREFREQ_DLY_STEP. In SYNC mode, the value for this field can be determined based on the rb_CLKPOS value to satisfy the internal setup and hold time of the SYNC signal with respect to the CLKIN signal. In SYSREF Repeater Mode, the value for this field can be used as a coarse global delay. Values greater than 0x3F are invalid. Since larger values include more delay steps, larger values have greater total step size variation across PVT relative to smaller values. Refer to the data sheet or the device TICS Pro profile for detailed description of the delay step computation procedure.
0	SYSREFREQ_CLR	R/W	1h	Clears SYSREFREQ_LATCH and resets synchronization path timing for SYSREFREQ signal. Holding this bit high keeps internal SYSREFREQ signal low in all modes except SYSREF repeater mode, overriding the state of SYSREFREQ_FORCE. This bit must be set and cleared once before the SYNC or clock position capture operations are performed.

**7.5.1.15 R16 Register (Offset = 10h) [Reset = 1005h]**

R16 is shown in [表 7-20](#).

Return to the [Summary Table](#).

**表 7-20. R16 Register Field Descriptions**

Bit	Field	Type	Reset	Description
15-12	SYSREF_PULSE_CNT	R/W	1h	Programs the number of pulses generated in pulser mode. The pulser is a counter gating the SYSREF divider; consequently, the pulse duration and frequency are equal to the duty cycle and frequency of the SYSREF divider output, respectively. 0h = Reserved 1h = 1 pulse 2h = 2 pulses Fh = 15 pulses
11-0	SYSREF_DIV	R/W	5h	Sets the SYSREF divider. Maximum input frequency from SYSREF_DIV_PRE must be ≤ 3200 MHz. Maximum output frequency must be ≤ 100 MHz. Odd divides (with duty cycle < 50%) are only allowed when the delay generators are bypassed. 0h = Reserved 1h = Reserved 2h = /2 3h = /3 FFFh = /4095

**7.5.1.16 R17 Register (Offset = 11h) [Reset = 07F0h]**

R17 is shown in [表 7-21](#).

Return to the [Summary Table](#).

**表 7-21. R17 Register Field Descriptions**

Bit	Field	Type	Reset	Description
15-11	UNDISCLOSED	R	0h	Program this field to 0x0.
10-4	SYSREF0_DLY_I	R/W	7Fh	Sets the delay step for the SYSREFOUT0 delay generator. Must satisfy SYSREFOUT0_DLY_I + SYSREFOUT0_DLY_Q = 127

表 7-21. R17 Register Field Descriptions (続き)

Bit	Field	Type	Reset	Description
3-2	SYSREF0_DLY_PHASE	R/W	0h	Sets the quadrature phase of the interpolator clock used for the SYSREFOUT0 delay generator retimer. 0h = ICLK' 1h = QCLK' 2h = ICLK 3h = QCLK
1-0	SYSREF_MODE	R/W	0h	Controls how the SYSREF signal is generated and is also impacted by the SYSREF_DLY_BYP field. Continuous mode generates a continuous SYSREF clock that is derived from the SYSREF divider and delay. In pulser mode, a pulse at the SYSREFREQ pin causes a specific number (determined by SYSREF_PULSE_CNT) of pulses to be generated for the SYSREF outputs. In Repeater mode, a pulse at the SYSREFREQ pins will generate a single pulse at the SYSREF outputs and only the propagation delay through the device is added. 0h = Continuous 1h = Pulser 2h = Repeater 3h = Reserved

#### 7.5.1.17 R18 Register (Offset = 12h) [Reset = FE00h]

R18 is shown in [表 7-22](#).

Return to the [Summary Table](#).

表 7-22. R18 Register Field Descriptions

Bit	Field	Type	Reset	Description
15-9	SYSREF1_DLY_I	R/W	7Fh	Sets the delay step for the SYSREFOUT0 delay generator. Must satisfy $SYSREFOUT0\_DLY\_I + SYSREFOUT0\_DLY\_Q = 127$
8-7	SYSREF1_DLY_PHASE	R/W	0h	Sets the quadrature phase of the interpolator clock used for the SYSREFOUT1 delay generator retimer. 0h = ICLK' 1h = QCLK' 2h = QCLK 3h = ICLK
6-0	SYSREF0_DLY_Q	R/W	0h	Determines the strength of QCLK for delay generation. Must satisfy $SYSREF0\_DLY\_I + SYSREF0\_DLY\_Q = 127$

#### 7.5.1.18 R19 Register (Offset = 13h) [Reset = FE00h]

R19 is shown in [表 7-23](#).

Return to the [Summary Table](#).

表 7-23. R19 Register Field Descriptions

Bit	Field	Type	Reset	Description
15-9	SYSREF2_DLY_I	R/W	7Fh	Determines the strength of ICLK for delay generation. Must satisfy $SYSREF2\_DLY\_I + SYSREF2\_DLY\_Q = 127$
8-7	SYSREF2_DLY_PHASE	R/W	0h	Sets the quadrature phase of the interpolator clock used for the SYSREFOUT2 delay generator retimer. 0h = ICLK' 1h = QCLK' 2h = QCLK 3h = ICLK
6-0	SYSREF1_DLY_Q	R/W	0h	Determines the strength of QCLK for delay generation. Must satisfy $SYSREF1\_DLY\_I + SYSREF1\_DLY\_Q = 127$

### 7.5.1.19 R20 Register (Offset = 14h) [Reset = FE00h]

R20 is shown in 表 7-24.

Return to the [Summary Table](#).

**表 7-24. R20 Register Field Descriptions**

Bit	Field	Type	Reset	Description
15-9	SYSREF3_DLY_I	R/W	7Fh	Sets the delay step for the SYSREFOUT1 delay generator. Must satisfy $SYSREFOUT1\_DLY\_I + SYSREFOUT1\_DLY\_Q = 127$
8-7	SYSREF3_DLY_PHASE	R/W	0h	Sets the quadrature phase of the interpolator clock used for the SYSREFOUT3 delay generator retimer. 0h = ICLK' 1h = QCLK' 2h = QCLK 3h = ICLK
6-0	SYSREF2_DLY_Q	R/W	0h	Determines the strength of QCLK for delay generation. Must satisfy $SYSREF3\_DLY\_I + SYSREF3\_DLY\_Q = 127$

### 7.5.1.20 R21 Register (Offset = 15h) [Reset = FE00h]

R21 is shown in 表 7-25.

Return to the [Summary Table](#).

**表 7-25. R21 Register Field Descriptions**

Bit	Field	Type	Reset	Description
15-9	LOGISYSREF_DLY_I	R/W	7Fh	Determines the strength of logic ICLK for delay generation. Must satisfy $LOGISYSREF\_DLY\_I + LOGISYSREF\_DLY\_Q = 127$
8-7	LOGISYSREF_DLY_PHASE	R/W	0h	Sets the quadrature phase of the interpolator clock used for the LOGISYSREFOUT delay generator retimer. 0h = ICLK' 1h = QCLK' 2h = QCLK 3h = ICLK
6-0	SYSREF3_DLY_Q	R/W	0h	Determines the strength of QCLK for delay generation. Must satisfy $SYSREFx\_DLY\_I + SYSREFx\_DLY\_Q = 127$

### 7.5.1.21 R22 Register (Offset = 16h) [Reset = 0800h]

R22 is shown in 表 7-26.

Return to the [Summary Table](#).

**表 7-26. R22 Register Field Descriptions**

Bit	Field	Type	Reset	Description
15-14	SYSREF1_DLY_SCALE	R/W	0h	Sets the frequency range of the SYSREFOUT1 delay generator. Set according to phase interpolator frequency. 0h = 400MHz to 800MHz 1h = 200MHz to 400MHz 2h = 150MHz to 200MHz 3h = Reserved
13-12	SYSREF0_DLY_SCALE	R/W	0h	Sets the frequency range of the SYSREFOUT0 delay generator. Set according to phase interpolator frequency. 0h = 400MHz to 800MHz 1h = 200MHz to 400MHz 2h = 150MHz to 200MHz 3h = Reserved

**表 7-26. R22 Register Field Descriptions (続き)**

Bit	Field	Type	Reset	Description
11-9	SYSREF_DLY_DIV	R/W	4h	Sets the delay generator clock division, determining the phase interpolator frequency and the delay generator resolution. Values other than those listed below are reserved. 0h = /1 (Up to 1.6GHz) 1h = /2 (1.6GHz to 3.2GHz) 2h = /4 (3.2GHz to 6.4GHz) 4h = /8 (6.4GHz to 12.8GHz)
8-7	UNDISCLOSED	R/W	0h	Program this field to 0x0.
6-0	LOGISYSREF_DLY_Q	R/W	0h	Sets the delay step for the LOGISYSREFOUT delay generator. Must satisfy LOGISYSREFOUT_DLY_I + LOGISYSREFOUT_DLY_Q = 127.

### 7.5.1.22 R23 Register (Offset = 17h) [Reset = 4000h]

R23 is shown in [表 7-27](#).

Return to the [Summary Table](#).

**表 7-27. R23 Register Field Descriptions**

Bit	Field	Type	Reset	Description
15	TS_EN	R/W	0h	Enables the on-die temperature sensor. Temperature sensor counter (TS_CNT_EN) must also be enabled for readback.
14	UNDISCLOSED	R/W	1h	Program this field to 0x1.
13	MUXOUT_EN	R/W	0h	Enables or tri-states the MUXOUT pin driver. 0h = Tri-States 1h = Push-Pull
12-7	UNDISCLOSED	R/W	0h	Program this field to 0x0.
6	MUXOUT_SEL	R/W	0h	Selects MUXOUT pin function. 0h = Lock Detect 1h = Readback
5-4	LOGISYSREF_DLY_SCALE	R/W	0h	Sets the frequency range of the LOGISYSREFOUT delay generator. Set according to phase interpolator frequency. 0h = 400MHz to 800MHz 1h = 200MHz to 400MHz 2h = 150MHz to 200MHz 3h = Reserved
3-2	SYSREF3_DLY_SCALE	R/W	0h	Sets the frequency range of the SYSREFOUT3 delay generator. Set according to phase interpolator frequency. 0h = 400MHz to 800MHz 1h = 200MHz to 400MHz 2h = 150MHz to 200MHz 3h = Reserved
1-0	SYSREF2_DLY_SCALE	R/W	0h	Sets the frequency range of the SYSREFOUT2 delay generator. Set according to phase interpolator frequency. 0h = 400MHz to 800MHz 1h = 200MHz to 400MHz 2h = 150MHz to 200MHz 3h = Reserved

### 7.5.1.23 R24 Register (Offset = 18h) [Reset = 0000h]

R24 is shown in [表 7-28](#).

Return to the [Summary Table](#).

**表 7-28. R24 Register Field Descriptions**

Bit	Field	Type	Reset	Description
15-14	UNDISCLOSED	R	0h	Program this field to 0x0.
13-12	UNDISCLOSED	R/W	0h	Program this field to 0x0.
11-1	rb_TS	R	0h	Readback value of on-die temperature sensor.
0	TS_CNT_EN	R/W	0h	Enables temperature sensor counter. Temperature sensor (EN_TS) must be enabled for accurate data.

#### 7.5.1.24 R25 Register (Offset = 19h) [Reset = 0211h]

R25 is shown in [表 7-29](#).

Return to the [Summary Table](#).

**表 7-29. R25 Register Field Descriptions**

Bit	Field	Type	Reset	Description
15-7	UNDISCLOSED	R/W	4h	Program this field to 0x4.
6	CLK_DIV_RST	R/W	0h	Resets the main clock divider. If the clock divider value is changed during operation, set this bit high then low after setting the new divider value. Synchronizing the device with the SYSREFREQ pins in SYSREFREQ_MODE = 0x0 and SYNC_EN = 0x1 also resets the main clock divider. This bit has no effect when outside of Divider Mode.
5-3	CLK_DIV	R/W	2h	CLK_DIV and CLK_MULT are aliases for the same field. When CLK_MUX=1 (Buffer Mode), this field is ignored. When CLK_MUX = 2 (Divider Mode), the clock divider is CLK_DIV + 1. Valid range for CLK_DIV is 1 to 7. Setting this to 0 disables the main clock divider and reverts to buffer mode. When CLK_MUX = 3 (Multiplier Mode), CLK_MULT the multiplier value is CLK_MULT. Valid range is 1 to 4. Setting outside this range disables multiplier mode and reverts to buffer mode. Valid range is 0x1 to 0x4.
2-0	CLK_MUX	R/W	1h	Selects the function for the main clock outputs 0h = Reserved 1h = Buffer 2h = Dividers 3h = Multiplier

#### 7.5.1.25 R28 Register (Offset = 1Ch) [Reset = 0A08h]

R28 is shown in [表 7-30](#).

Return to the [Summary Table](#).

**表 7-30. R28 Register Field Descriptions**

Bit	Field	Type	Reset	Description
15-13	UNDISCLOSED	R	0h	Program this field to 0x0.
12	VCO_CORE_FORCE	R/W	0h	Forces the multiplier PLL's VCO to the value selected by VCO_CORE. Not required for Multiplier Mode programming, but can optionally be used to reduce calibration time.
11-9	VCO_CORE	R/W	5h	When VCO_CORE_FORCE=0, specifies start VCO for multiplier calibration. When VCO_CORE_FORCE=1, this VCO core is forced. Programming of this field is not required for Multiplier Mode programming, but can be used to debugging purposes or to reduce calibration time.
8-0	UNDISCLOSED	R/W	8h	Program this field to 0x8.

### 7.5.1.26 R29 Register (Offset = 1Dh) [Reset = 05FFh]

R29 is shown in [表 7-31](#).

Return to the [Summary Table](#).

**表 7-31. R29 Register Field Descriptions**

Bit	Field	Type	Reset	Description
15-13	UNDISCLOSED	R	0h	Program this field to 0x0.
12-8	UNDISCLOSED	R/W	5h	Program this field to 0x5.
7-0	VCO_CAPCTRL	R/W	FFh	Sets the starting value for the VCO tuning capacitance during multiplier calibration. Not required for Multiplier Mode programming, but can be used to reduce calibration time.

### 7.5.1.27 R33 Register (Offset = 21h) [Reset = 7777h]

R33 is shown in [表 7-32](#).

Return to the [Summary Table](#).

**表 7-32. R33 Register Field Descriptions**

Bit	Field	Type	Reset	Description
15-0	UNDISCLOSED	R/W	7777h	Program this field to 0x6666. Note that this is different than the reset value.

### 7.5.1.28 R34 Register (Offset = 22h) [Reset = 0007h]

R34 is shown in [表 7-33](#).

Return to the [Summary Table](#).

**表 7-33. R34 Register Field Descriptions**

Bit	Field	Type	Reset	Description
15-14	UNDISCLOSED	R	0h	Program this field to 0x0.
13-0	UNDISCLOSED	R/W	7h	Program this field to 0x5. Note that this is different than the reset value.

### 7.5.1.29 R65 Register (Offset = 41h) [Reset = 65F0h]

R65 is shown in [表 7-34](#).

Return to the [Summary Table](#).

**表 7-34. R65 Register Field Descriptions**

Bit	Field	Type	Reset	Description
15-9	UNDISCLOSED	R/W	32h	Program this field to 0x32.
8-4	rb_VCO_CORE	R	1Fh	Readback for the multiplier VCO Core. There are only valid values and the VCO is determined by the bit that is low. Fh = VCO1 17h = VCO2 1Bh = VCO3 1Dh = VCO4 1Eh = VCO5
3-0	UNDISCLOSED	R/W	0h	Program this field to 0x0.

### 7.5.1.30 R67 Register (Offset = 43h) [Reset = 50C8h]

R67 is shown in [表 7-35](#).

Return to the [Summary Table](#).

**表 7-35. R67 Register Field Descriptions**

Bit	Field	Type	Reset	Description
15-0	UNDISCLOSED	R/W	50C8h	Program this field to 0x51CB. Note that this is different than the reset value.

### 7.5.1.31 R72 Register (Offset = 48h) [Reset = 0000h]

R72 is shown in [表 7-36](#).

Return to the [Summary Table](#).

**表 7-36. R72 Register Field Descriptions**

Bit	Field	Type	Reset	Description
15	UNDISCLOSED	R	0h	Program this field to 0x0.
14-3	UNDISCLOSED	R/W	0h	Program this field to 0x0.
2	SYSREFREQ_FORCE	R/W	0h	Setting this bit emulates the behavior of a logic HIGH at SYSREFREQ pins and causes external signals on SYSREFREQ pins to be ignored.
1-0	SYSREF_DLY_BYP	R/W	0h	Option to bypass delay generator retiming. Under normal circumstances (SYSREF_DLY_BYP = 0) the delay generator is engaged for continuous or pulser modes (Generator Modes), and bypassed in Repeater Mode. Generally this typically utilize a different delay mechanism. In certain cases, bypassing the delay generator retiming in Generator Mode by setting SYSREF_DLY_BYP = 1 can substantially reduce the device current consumption if the SYSREF delay can be compensated at the JESD receiver. In other cases, retiming the SYSREFREQ signal to the delay generators by setting SYSREF_DLY_BYP = 2 can improve the accuracy of the SYSREF output phase with respect to the CLKIN phase, or can vary the delay of individual outputs independently, as long as coherent phase relationship exists between the interpolator divider phase and the SYSREFREQ phase. 0h = Engage in Generator Mode, Bypass in Repeater Mode 1h = Bypass in All Modes 2h = Engage in All Modes 3h = Reserved

### 7.5.1.32 R73 Register (Offset = 49h) [Reset = 0000h]

R73 is shown in [表 7-37](#).

Return to the [Summary Table](#).

**表 7-37. R73 Register Field Descriptions**

Bit	Field	Type	Reset	Description
15-13	UNDISCLOSED	R	0h	Program this field to 0x0.
12-0	UNDISCLOSED	R/W	0h	Program this field to 0x1000. Note that this is different than the reset value.

### 7.5.1.33 R75 Register (Offset = 4Bh) [Reset = 0006h]

R75 is shown in [表 7-38](#).



Return to the [Summary Table](#).

**表 7-38. R75 Register Field Descriptions**

Bit	Field	Type	Reset	Description
15	rb_CLK2_EN	R	0h	Readback Pin Status
14	rb_CLK1_EN	R	0h	Readback Pin Status
13	rb_CLK0_EN	R	0h	Readback Pin Status
12	rb_MUXSEL1	R	0h	Readback Pin Status
11	rb_MUXSEL0	R	0h	Readback Pin Status
10	rb_LOGIC_EN	R	0h	Readback Pin Status
9-8	rb_LD	R	0h	Readback for Multiplier PLL lock detect. 0h = Unlocked (VTUNE low) 1h = Reserved 2h = Locked 3h = Unlocked (VTUNE high)
7	rb_DIVSEL2	R	0h	Readback Pin Status
6	rb_DIVSEL1	R	0h	Readback Pin Status
5	rb_DIVSEL0	R	0h	Readback Pin Status
4	rb_CE	R	0h	Readback Pin Status
3-0	UNDISCLOSED	R/W	6h	Program this field to 0x3. Note that this is different than the reset value.

#### 7.5.1.34 R76 Register (Offset = 4Ch) [Reset = 0000h]

R76 is shown in [表 7-39](#).

Return to the [Summary Table](#).

**表 7-39. R76 Register Field Descriptions**

Bit	Field	Type	Reset	Description
15-4	UNDISCLOSED	R/W	0h	Program this field to 0x0.
3	rb_PWRSEL2	R	0h	Readback Pin Status
2	rb_PWRSEL1	R	0h	Readback Pin Status
1	rb_PWRSEL0	R	0h	Readback Pin Status
0	rb_CLK3_EN	R	0h	Readback Pin Status

#### 7.5.1.35 R86 Register (Offset = 56h) [Reset = 0000h]

R86 is shown in [表 7-40](#).

Return to the [Summary Table](#).

**表 7-40. R86 Register Field Descriptions**

Bit	Field	Type	Reset	Description
15-3	UNDISCLOSED	R/W	0h	Program this field to 0x0.
2	MUXOUT_EN_OVRD	R/W	0h	No description
1-0	UNDISCLOSED	R/W	0h	Program this field to 0x0.

#### 7.5.1.36 R90 Register (Offset = 5Ah) [Reset = 0000h]

R90 is shown in [表 7-41](#).

Return to the [Summary Table](#).

**表 7-41. R90 Register Field Descriptions**

Bit	Field	Type	Reset	Description
15-8	UNDISCLOSED	R	0h	Program this field to 0x0.
7	UNDISCLOSED	R/W	0h	Program this field to 0x0.
6	LOGICLK_DIV_BYP3	R/W	0h	This bit should be set to 1 if LOGICLK_DIV_BYP=1, 0 otherwise.
5	LOGICLK_DIV_BYP2	R/W	0h	This bit should be set to 1 if LOGICLK_DIV_BYP=1, 0 otherwise.
4-0	UNDISCLOSED	R/W	0h	Program this field to 0x0.

## 8 Device and Documentation Support

### 8.1 Device Support

TI offers an extensive line of development tools and software to simulate the device performance and program the device.

**表 8-1. Development Tools and Software**

TOOL	TYPE	DESCRIPTION
<a href="#">PLLatinum™ Sim</a>	Software	Simulates phase noise in all modes
<a href="#">TICS Pro</a>	Software	Programs the device with a user-friendly GUI with interactive feedback and hex register export.

### 8.2 Documentation Support

#### 8.2.1 Related Documentation

- Texas Instruments, [LMX1860-SEP Evaluation Module](#), EVM user's guide

### 8.3 ドキュメントの更新通知を受け取る方法

ドキュメントの更新についての通知を受け取るには、[www.tij.co.jp](http://www.tij.co.jp) のデバイス製品フォルダを開いてください。[通知] をクリックして登録すると、変更されたすべての製品情報に関するダイジェストを毎週受け取ることができます。変更の詳細については、改訂されたドキュメントに含まれている改訂履歴をご覧ください。

### 8.4 サポート・リソース

[テキサス・インスツルメンツ E2E™ サポート・フォーラム](#)は、エンジニアが検証済みの回答と設計に関するヒントをエキスパートから迅速かつ直接得ることができる場所です。既存の回答を検索したり、独自の質問をしたりすることで、設計に必要な支援を迅速に得ることができます。

リンクされているコンテンツは、各寄稿者により「現状のまま」提供されるものです。これらはテキサス・インスツルメンツの仕様を構成するものではなく、必ずしもテキサス・インスツルメンツの見解を反映したものではありません。テキサス・インスツルメンツの[使用条件](#)を参照してください。

### 8.5 Trademarks

PLLatinum™ and テキサス・インスツルメンツ E2E™ are trademarks of Texas Instruments.

Rohde & Schwarz® is a registered trademark of Rohde & Schwarz GmbH & Co KG.

すべての商標は、それぞれの所有者に帰属します。

### 8.6 静電気放電に関する注意事項



この IC は、ESD によって破損する可能性があります。テキサス・インスツルメンツは、IC を取り扱う際には常に適切な注意を払うことを推奨します。正しい取り扱いおよび設置手順に従わない場合、デバイスを破損するおそれがあります。

ESD による破損は、わずかな性能低下からデバイスの完全な故障まで多岐にわたります。精密な IC の場合、パラメータがわずかに変化するだけで公表されている仕様から外れる可能性があるため、破損が発生しやすくなっています。

## 8.7 用語集

[テキサス・インスツルメンツ用語集](#) この用語集には、用語や略語の一覧および定義が記載されています。

## 9 Revision History

資料番号末尾の英字は改訂を表しています。その改訂履歴は英語版に準じています。

DATE	REVISION	NOTES
June 2024	*	Initial release

## 10 Mechanical, Packaging, and Orderable Information

The following pages include mechanical, packaging, and orderable information. This information is the most current data available for the designated devices. This data is subject to change without notice and revision of this document. For browser-based versions of this data sheet, refer to the left-hand navigation.



## EXAMPLE BOARD LAYOUT

PAP0064E

PowerPAD™ TQFP - 1.2 mm max height

PLASTIC QUAD FLATPACK

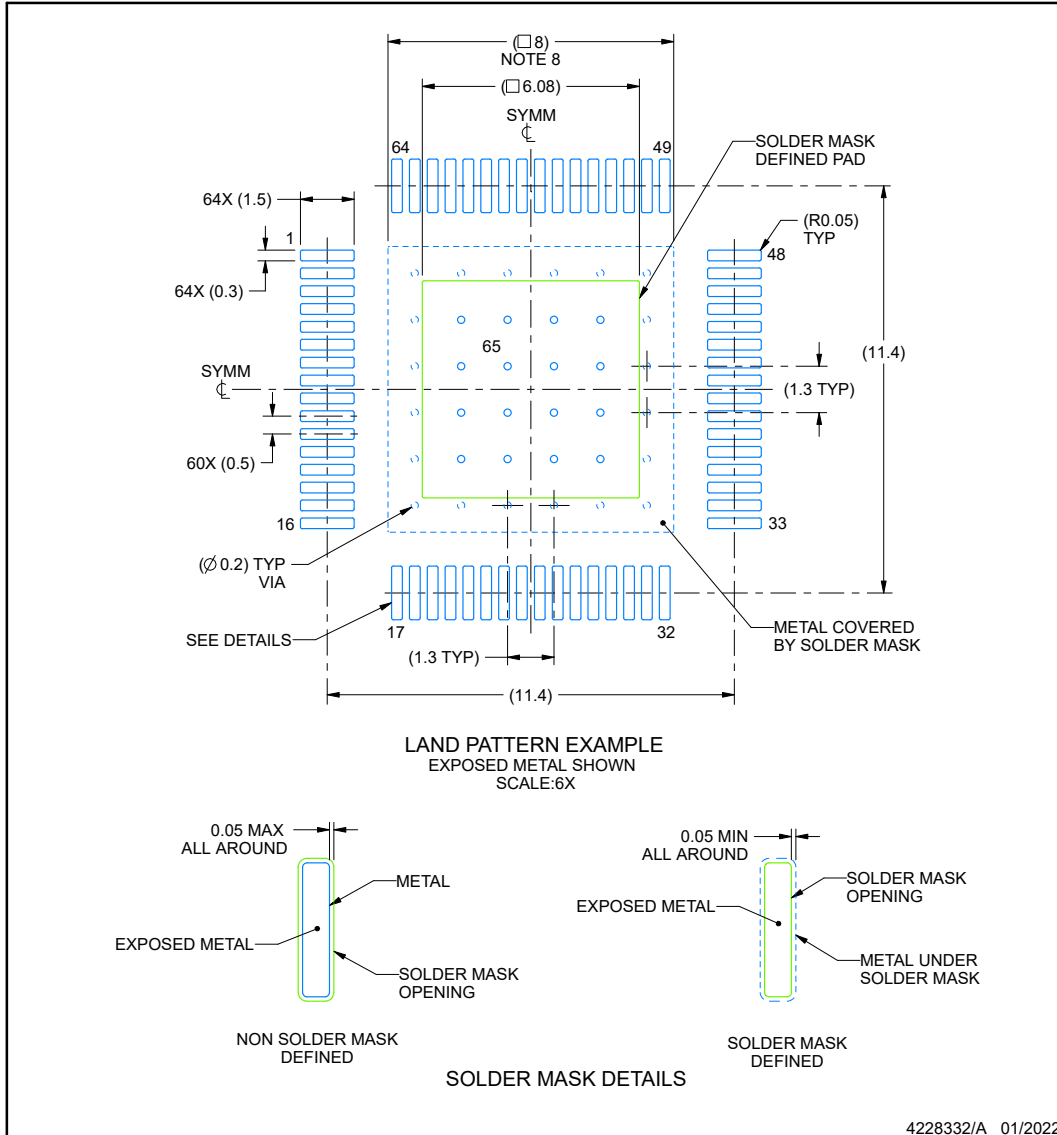

NOTES: (continued)

6. Publication IPC-7351 may have alternate designs.
7. Solder mask tolerances between and around signal pads can vary based on board fabrication site.
8. This package is designed to be soldered to a thermal pad on the board. See technical brief, Powerpad thermally enhanced package, Texas Instruments Literature No. SLMA002 ([www.ti.com/lit/slma002](http://www.ti.com/lit/slma002)) and SLMA004 ([www.ti.com/lit/slma004](http://www.ti.com/lit/slma004)).
9. Vias are optional depending on application, refer to device data sheet. It is recommended that vias under paste be filled, plugged or tented.
10. Size of metal pad may vary due to creepage requirement.



## 重要なお知らせと免責事項

テキサス・インスツルメンツは、技術データと信頼性データ (データシートを含みます)、設計リソース (リファレンス デザインを含みます)、アプリケーションや設計に関する各種アドバイス、Web ツール、安全性情報、その他のリソースを、欠陥が存在する可能性のある「現状のまま」提供しており、商品性および特定目的に対する適合性の黙示保証、第三者の知的財産権の非侵害保証を含むいかなる保証も、明示的または黙示的にかかわらず拒否します。

これらのリソースは、テキサス・インスツルメンツ製品を使用する設計の経験を積んだ開発者への提供を意図したものです。(1) お客様のアプリケーションに適した テキサス・インスツルメンツ製品の選定、(2) お客様のアプリケーションの設計、検証、試験、(3) お客様のアプリケーションに該当する各種規格や、その他のあらゆる安全性、セキュリティ、規制、または他の要件への確実な適合に関する責任を、お客様のみが単独で負うものとします。

上記の各種リソースは、予告なく変更される可能性があります。これらのリソースは、リソースで説明されている テキサス・インスツルメンツ製品を使用するアプリケーションの開発の目的でのみ、テキサス・インスツルメンツはその使用をお客様に許諾します。これらのリソースに関して、他の目的で複製することや掲載することは禁止されています。テキサス・インスツルメンツや第三者の知的財産権のライセンスが付与されている訳ではありません。お客様は、これらのリソースを自身で使用した結果発生するあらゆる申し立て、損害、費用、損失、責任について、テキサス・インスツルメンツおよびその代理人を完全に補償するものとし、テキサス・インスツルメンツは一切の責任を拒否します。

テキサス・インスツルメンツの製品は、[テキサス・インスツルメンツの販売条件](#)、または [ti.com](https://www.ti.com) やかかる テキサス・インスツルメンツ製品の関連資料などのいずれかを通じて提供する適用可能な条項の下で提供されています。テキサス・インスツルメンツがこれらのリソースを提供することは、適用されるテキサス・インスツルメンツの保証または他の保証の放棄の拡大や変更を意味するものではありません。

お客様がいかなる追加条項または代替条項を提案した場合でも、テキサス・インスツルメンツはそれらに異議を唱え、拒否します。

郵送先住所: Texas Instruments, Post Office Box 655303, Dallas, Texas 75265

Copyright © 2024, Texas Instruments Incorporated

**PACKAGING INFORMATION**

Orderable Device	Status (1)	Package Type	Package Drawing	Pins	Package Qty	Eco Plan (2)	Lead finish/ Ball material (6)	MSL Peak Temp (3)	Op Temp (°C)	Device Marking (4/5)	Samples
LMX1860MPAPSEP	ACTIVE	HTQFP	PAP	64	250	RoHS & Green	NIPDAU	Level-3-260C-168 HR	-55 to 125	LMX1860 (MPAPSEP, PAPSEP)	<a href="#">Samples</a>
LMX1860PAP/EM	ACTIVE	HTQFP	PAP	64	250	RoHS & Green	NIPDAU	Level-3-260C-168 HR	-55 to 125	LMX1860 PAP/EM	<a href="#">Samples</a>
V62/24630-01XE	ACTIVE	HTQFP	PAP	64	250	RoHS & Green	NIPDAU	Level-3-260C-168 HR	-55 to 125	LMX1860 (MPAPSEP, PAPSEP)	<a href="#">Samples</a>

(1) The marketing status values are defined as follows:

**ACTIVE:** Product device recommended for new designs.

**LIFEBUY:** TI has announced that the device will be discontinued, and a lifetime-buy period is in effect.

**NRND:** Not recommended for new designs. Device is in production to support existing customers, but TI does not recommend using this part in a new design.

**PREVIEW:** Device has been announced but is not in production. Samples may or may not be available.

**OBSOLETE:** TI has discontinued the production of the device.

(2) **RoHS:** TI defines "RoHS" to mean semiconductor products that are compliant with the current EU RoHS requirements for all 10 RoHS substances, including the requirement that RoHS substance do not exceed 0.1% by weight in homogeneous materials. Where designed to be soldered at high temperatures, "RoHS" products are suitable for use in specified lead-free processes. TI may reference these types of products as "Pb-Free".

**RoHS Exempt:** TI defines "RoHS Exempt" to mean products that contain lead but are compliant with EU RoHS pursuant to a specific EU RoHS exemption.

**Green:** TI defines "Green" to mean the content of Chlorine (Cl) and Bromine (Br) based flame retardants meet JS709B low halogen requirements of <=1000ppm threshold. Antimony trioxide based flame retardants must also meet the <=1000ppm threshold requirement.

(3) MSL, Peak Temp. - The Moisture Sensitivity Level rating according to the JEDEC industry standard classifications, and peak solder temperature.

(4) There may be additional marking, which relates to the logo, the lot trace code information, or the environmental category on the device.

(5) Multiple Device Markings will be inside parentheses. Only one Device Marking contained in parentheses and separated by a "~" will appear on a device. If a line is indented then it is a continuation of the previous line and the two combined represent the entire Device Marking for that device.

(6) Lead finish/Ball material - Orderable Devices may have multiple material finish options. Finish options are separated by a vertical ruled line. Lead finish/Ball material values may wrap to two lines if the finish value exceeds the maximum column width.

**Important Information and Disclaimer:** The information provided on this page represents TI's knowledge and belief as of the date that it is provided. TI bases its knowledge and belief on information provided by third parties, and makes no representation or warranty as to the accuracy of such information. Efforts are underway to better integrate information from third parties. TI has taken and continues to take reasonable steps to provide representative and accurate information but may not have conducted destructive testing or chemical analysis on incoming materials and chemicals. TI and TI suppliers consider certain information to be proprietary, and thus CAS numbers and other limited information may not be available for release.



In no event shall TI's liability arising out of such information exceed the total purchase price of the TI part(s) at issue in this document sold by TI to Customer on an annual basis.

**TAPE AND REEL INFORMATION**

**QUADRANT ASSIGNMENTS FOR PIN 1 ORIENTATION IN TAPE**

\*All dimensions are nominal

Device	Package Type	Package Drawing	Pins	SPQ	Reel Diameter (mm)	Reel Width W1 (mm)	A0 (mm)	B0 (mm)	K0 (mm)	P1 (mm)	W (mm)	Pin1 Quadrant
LMX1860PAP/EM	HTQFP	PAP	64	250	178.0	24.4	13.0	13.0	1.5	16.0	24.0	Q2

**TAPE AND REEL BOX DIMENSIONS**

\*All dimensions are nominal

Device	Package Type	Package Drawing	Pins	SPQ	Length (mm)	Width (mm)	Height (mm)
LMX1860PAP/EM	HTQFP	PAP	64	250	213.0	191.0	55.0

# PAP0064E

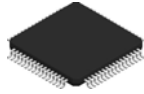

# PACKAGE OUTLINE

PowerPAD™ TQFP - 1.2 mm max height

PLASTIC QUAD FLATPACK

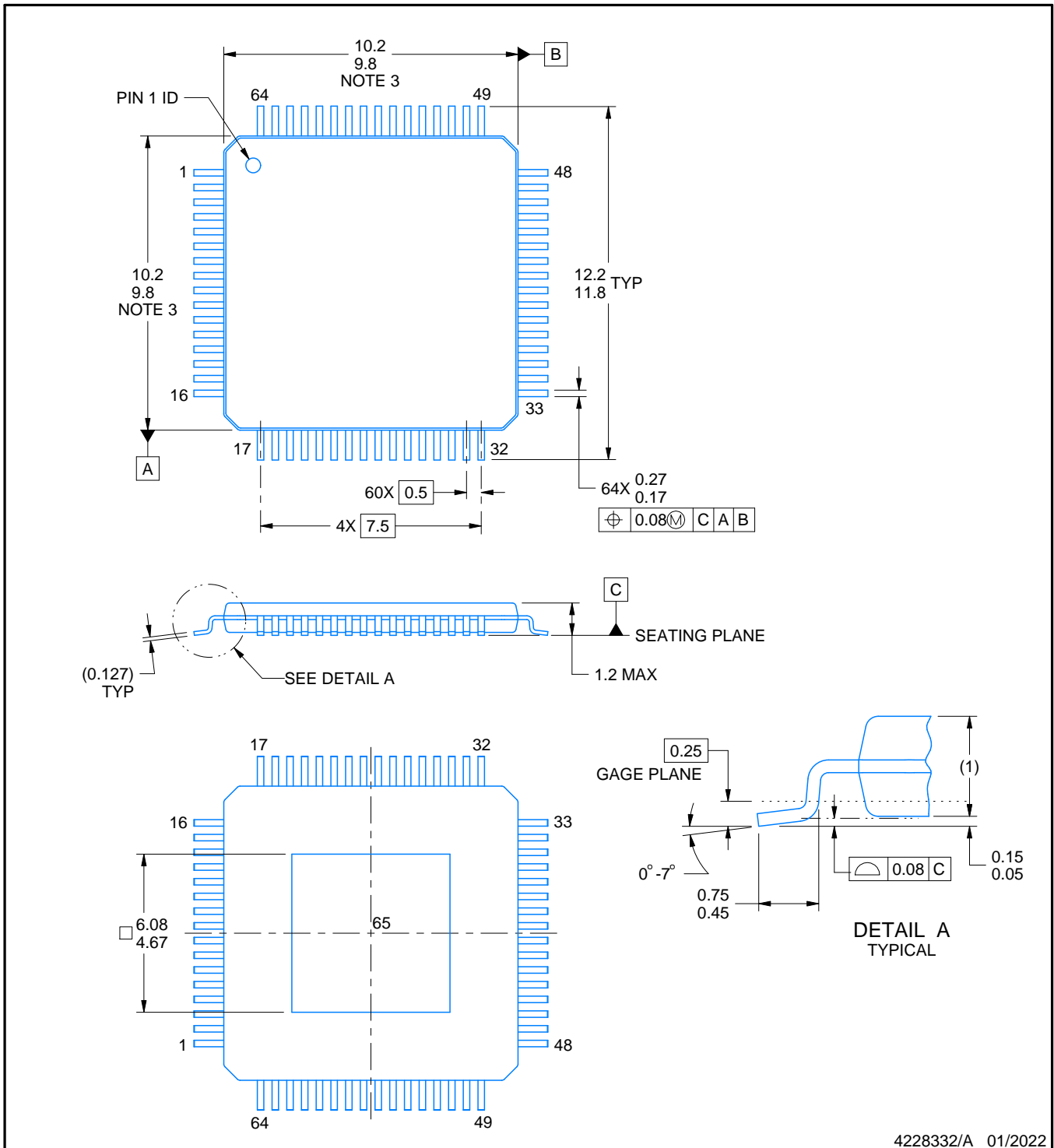

4228332/A 01/2022

**NOTES:**

PowerPAD is a trademark of Texas Instruments.

1. All linear dimensions are in millimeters. Any dimensions in parenthesis are for reference only. Dimensioning and tolerancing per ASME Y14.5M.
2. This drawing is subject to change without notice.
3. This dimension does not include mold flash, protrusions, or gate burrs.
4. Strap features may not be present.
5. Reference JEDEC registration MS-026.

# EXAMPLE BOARD LAYOUT

PAP0064E

PowerPAD™ TQFP - 1.2 mm max height

PLASTIC QUAD FLATPACK

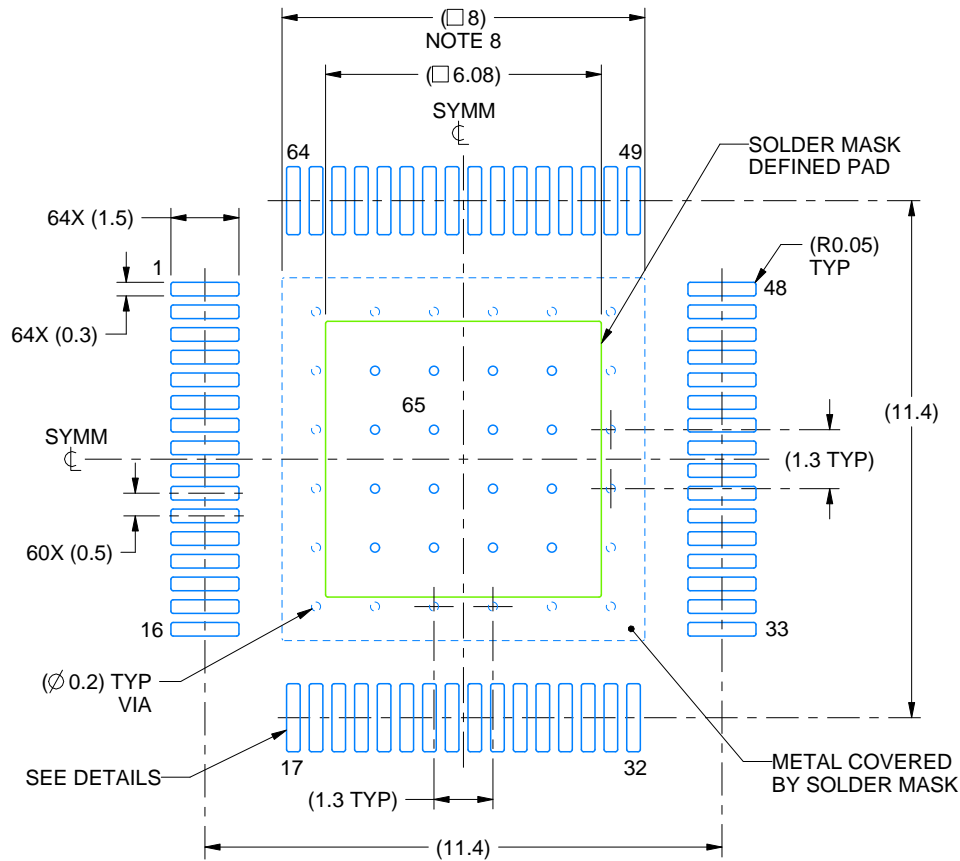

LAND PATTERN EXAMPLE  
EXPOSED METAL SHOWN  
SCALE:6X

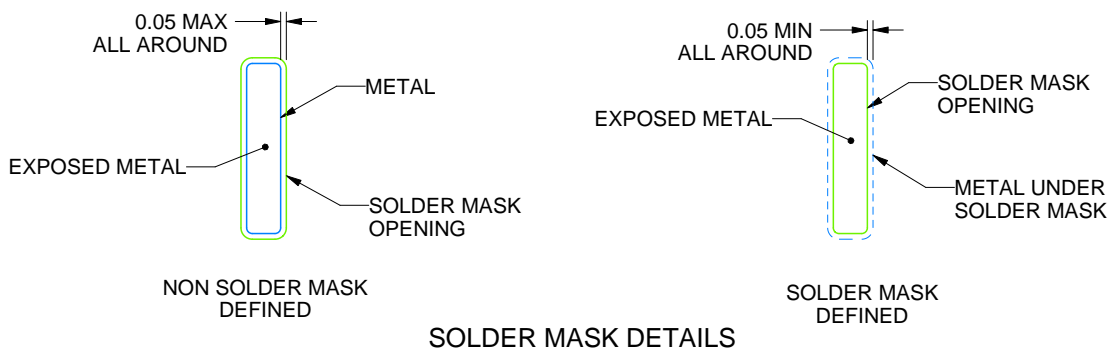

4228332/A 01/2022

NOTES: (continued)

6. Publication IPC-7351 may have alternate designs.
7. Solder mask tolerances between and around signal pads can vary based on board fabrication site.
8. This package is designed to be soldered to a thermal pad on the board. See technical brief, Powerpad thermally enhanced package, Texas Instruments Literature No. SLMA002 ([www.ti.com/lit/slma002](http://www.ti.com/lit/slma002)) and SLMA004 ([www.ti.com/lit/slma004](http://www.ti.com/lit/slma004)).
9. Vias are optional depending on application, refer to device data sheet. It is recommended that vias under paste be filled, plugged or tented.
10. Size of metal pad may vary due to creepage requirement.

# EXAMPLE STENCIL DESIGN

PAP0064E

PowerPAD™ TQFP - 1.2 mm max height

PLASTIC QUAD FLATPACK

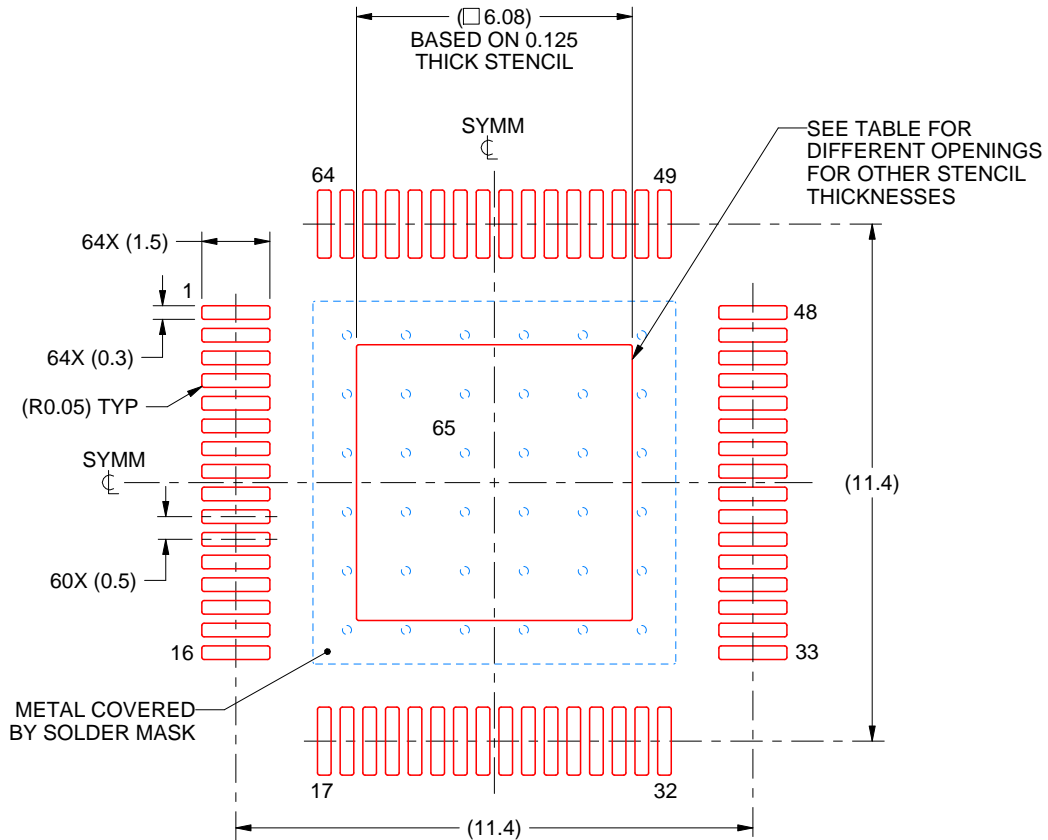

**SOLDER PASTE EXAMPLE**  
 EXPOSED PAD  
 100% PRINTED SOLDER COVERAGE BY AREA  
 SCALE:6X

STENCIL THICKNESS	SOLDER STENCIL OPENING
0.1	6.80 X 6.80
0.125	6.08 X 6.08 (SHOWN)
0.15	5.55 X 5.55
0.175	5.14 X 5.14

4228332/A 01/2022

NOTES: (continued)

- 11. Laser cutting apertures with trapezoidal walls and rounded corners may offer better paste release. IPC-7525 may have alternate design recommendations.
- 12. Board assembly site may have different recommendations for stencil design.

## 重要なお知らせと免責事項

TI は、技術データと信頼性データ(データシートを含みます)、設計リソース(リファレンス・デザインを含みます)、アプリケーションや設計に関する各種アドバイス、Web ツール、安全性情報、その他のリソースを、欠陥が存在する可能性のある「現状のまま」提供しており、商品性および特定目的に対する適合性の黙示保証、第三者の知的財産権の非侵害保証を含むいかなる保証も、明示的または黙示的にかかわらず拒否します。

これらのリソースは、TI 製品を使用する設計の経験を積んだ開発者への提供を意図したものです。(1) お客様のアプリケーションに適した TI 製品の選定、(2) お客様のアプリケーションの設計、検証、試験、(3) お客様のアプリケーションに該当する各種規格や、その他のあらゆる安全性、セキュリティ、規制、または他の要件への確実な適合に関する責任を、お客様のみが単独で負うものとします。

上記の各種リソースは、予告なく変更される可能性があります。これらのリソースは、リソースで説明されている TI 製品を使用するアプリケーションの開発の目的でのみ、TI はその使用をお客様に許諾します。これらのリソースに関して、他の目的で複製することや掲載することは禁止されています。TI や第三者の知的財産権のライセンスが付与されている訳ではありません。お客様は、これらのリソースを自身で使用した結果発生するあらゆる申し立て、損害、費用、損失、責任について、TI およびその代理人を完全に補償するものとし、TI は一切の責任を拒否します。

TI の製品は、[TI の販売条件](#)、または [ti.com](#) やかかる TI 製品の関連資料などのいずれかを通じて提供する適用可能な条項の下で提供されています。TI がこれらのリソースを提供することは、適用される TI の保証または他の保証の放棄の拡大や変更を意味するものではありません。

お客様がいかなる追加条項または代替条項を提案した場合でも、TI はそれらに異議を唱え、拒否します。

郵送先住所 : Texas Instruments, Post Office Box 655303, Dallas, Texas 75265  
Copyright © 2024, Texas Instruments Incorporated