

# OPAx993 32V, Rail-to-Rail Input and Output, 20MHz, Low-Power Op Amp

## 1 Features

- Rail-to-rail input and output
- Wide supply voltage: 2.7V to 32V
- Wide bandwidth: 20MHz GBW, unity-gain stable
- High slew rate: 40V/μs
- Low quiescent current: 400μA per amplifier
- Low offset voltage: ±1mV (maximum)
- Low offset voltage drift: ±3μV/°C (maximum)
- Low noise: 13nV/√Hz at 1kHz
- Low 1/f noise: 0.5μV (peak-to-peak)
- Low THD+N: 0.00014% (117dB)
- Industry standard packages:
  - Dual in SOIC-8, VSSOP-8, and SOT-23-THIN-8
  - Quad in SOIC-14, TSSOP-14, and SOT-23-THIN-14

## 2 Applications

- [AC charging \(pile\) station](#)
- [GFCI fault detection and test](#)
- [Software defined radio](#)
- [Display panel for PC and notebooks](#)
- [LCD TV](#)
- [Wireless control lighting](#)
- [Motor drive: power stage and control modules](#)
- [Power delivery: UPS, server, and merchant network power](#)
- [ADC driver and reference buffer amplifier](#)
- [High-side and low-side current sensing](#)

## 3 Description

The OPA2993 and OPA4993 (OPAx993) are part of a family of high-voltage (32V), rail-to-rail input and output (RRIO) operational amplifiers. These devices offer excellent ac performance, including a wide unity gain bandwidth of 20MHz, and a high slew rate of 40V/μs, while only requiring a quiescent current of 400μA per channel.

These devices also offer excellent dc precision, low offset voltage (±1mV, maximum), and low offset drift (±3μV/°C, maximum) for high-voltage operation within the main input pair. These features make the OPAx993 a flexible, robust, and high-performance op amp for high-voltage industrial applications.

The OPAx993 family of op amps is available in small-size packages (such as SOT-23-8 and SOT-23-14), as well as standard packages (such as SOIC, and TSSOP), and is specified from –40°C to +125°C.

### Device Information

| PART NUMBER <sup>(1)</sup> | CHANNEL COUNT | PACKAGE                         | PACKAGE SIZE <sup>(3)</sup> |
|----------------------------|---------------|---------------------------------|-----------------------------|
| OPA2993                    | Dual          | D (SOIC, 8)                     | 4.9mm × 6mm                 |
|                            |               | DGK (VSSOP, 8) <sup>(2)</sup>   | 3mm × 4.9mm                 |
|                            |               | DDF (SOT-23, 8) <sup>(2)</sup>  | 2.9mm × 2.8mm               |
| OPA4993                    | Quad          | D (SOIC, 14) <sup>(2)</sup>     | 8.65mm × 6mm                |
|                            |               | DYY (SOT-23, 14) <sup>(2)</sup> | 4.2mm × 1.9mm               |
|                            |               | PW (TSSOP, 14) <sup>(2)</sup>   | 5mm × 6.4mm                 |

(1) For more information, see [Section 10](#).

(2) Preview information (not Production Data).

(3) The package size (length × width) is a nominal value and includes pins, where applicable.

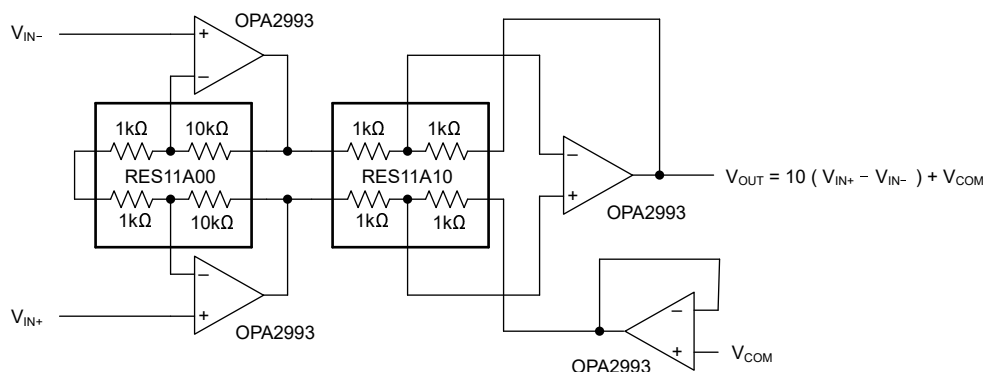

OPAx993 Instrumentation Application With the RES11



## Table of Contents

|  |           |  |           |
|--|-----------|--|-----------|
| <b>1 Features</b> .....                        | <b>1</b>  | <b>7 Application and Implementation</b> .....                    | <b>16</b> |
| <b>2 Applications</b> .....                    | <b>1</b>  | 7.1 Application Information.....                                 | 16        |
| <b>3 Description</b> .....                     | <b>1</b>  | 7.2 Typical Applications.....                                    | 16        |
| <b>4 Pin Configuration and Functions</b> ..... | <b>2</b>  | 7.3 Power Supply Recommendations.....                            | 17        |
| <b>5 Specifications</b> .....                  | <b>4</b>  | 7.4 Layout.....  | 18        |
| 5.1 Absolute Maximum Ratings.....              | 4         | <b>8 Device and Documentation Support</b> .....                  | <b>20</b> |
| 5.2 ESD Ratings.....                           | 4         | 8.1 Device Support.....  | 20        |
| 5.3 Recommended Operating Conditions.....      | 4         | 8.2 Documentation Support.....                                   | 20        |
| 5.4 Thermal Information OPA2993.....           | 5         | 8.3 Receiving Notification of Documentation Updates....          | 20        |
| 5.5 Electrical Characteristics.....            | 6         | 8.4 Support Resources.....                                       | 20        |
| 5.6 Typical Characteristics.....               | 9         | 8.5 Trademarks.....  | 20        |
| <b>6 Detailed Description</b> .....            | <b>12</b> | 8.6 Electrostatic Discharge Caution.....                         | 20        |
| 6.1 Overview.....                              | 12        | 8.7 Glossary.....  | 20        |
| 6.2 Functional Block Diagram.....              | 12        | <b>9 Revision History</b> .....                                  | <b>21</b> |
| 6.3 Feature Description.....                   | 12        | <b>10 Mechanical, Packaging, and Orderable Information</b> ..... | <b>21</b> |
| 6.4 Device Functional Modes.....               | 15        |  |           |

## 4 Pin Configuration and Functions

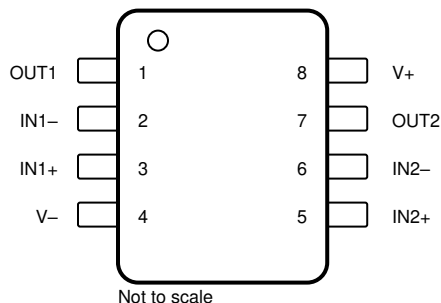

**Figure 4-1. OPA2993: D Package, 8-Pin SOIC, DGK (Preview) Package, 8-Pin VSSOP, and DDF (Preview) Package, 8-Pin SOT-23-THN (Top View)**

**Table 4-1. Pin Functions: OPA2993**

| PIN  |     | TYPE   | DESCRIPTION                     |
|------|-----|--------|---------------------------------|
| NAME | NO. |        |                                 |
| IN1- | 2   | Input  | Inverting input, channel 1      |
| IN1+ | 3   | Input  | Noninverting input, channel 1   |
| IN2- | 6   | Input  | Inverting input, channel 2      |
| IN2+ | 5   | Input  | Noninverting input, channel 2   |
| OUT1 | 1   | Output | Output, channel 1               |
| OUT2 | 7   | Output | Output, channel 2               |
| V-   | 4   | —      | Negative (lowest) power supply  |
| V+   | 8   | —      | Positive (highest) power supply |

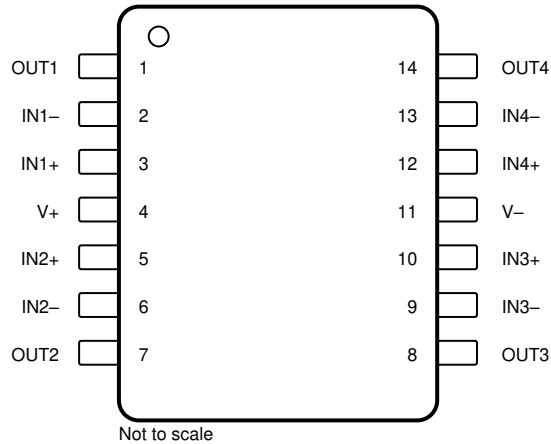

**Figure 4-2. OPA4993: D (Preview) Package, 14-Pin SOIC, and PW (Preview) Package, 14-Pin TSSOP (Top View)**

**Table 4-2. Pin Functions: OPA4993**

| PIN  |     | TYPE   | DESCRIPTION                     |
|------|-----|--------|---------------------------------|
| NAME | NO. |        |                                 |
| IN1- | 2   | Input  | Inverting input, channel 1      |
| IN1+ | 3   | Input  | Noninverting input, channel 1   |
| IN2- | 6   | Input  | Inverting input, channel 2      |
| IN2+ | 5   | Input  | Noninverting input, channel 2   |
| IN3- | 9   | Input  | Inverting input, channel 3      |
| IN3+ | 10  | Input  | Noninverting input, channel 3   |
| IN4- | 13  | Input  | Inverting input, channel 4      |
| IN4+ | 12  | Input  | Noninverting input, channel 4   |
| OUT1 | 1   | Output | Output, channel 1               |
| OUT2 | 7   | Output | Output, channel 2               |
| OUT3 | 8   | Output | Output, channel 3               |
| OUT4 | 14  | Output | Output, channel 4               |
| V-   | 11  | —      | Negative (lowest) power supply  |
| V+   | 4   | —      | Positive (highest) power supply |

## 5 Specifications

### 5.1 Absolute Maximum Ratings

over operating ambient temperature range (unless otherwise noted)<sup>(1)</sup>

|                                      |                                     | MIN          | MAX          | UNIT |
|--------------------------------------|-------------------------------------|--------------|--------------|------|
| Supply voltage, $V_S = (V+) - (V-)$  |                                     | 0            | 33           | V    |
| Signal input pins                    | Common-mode voltage <sup>(3)</sup>  | $(V-) - 0.5$ | $(V+) + 0.5$ | V    |
|                                      | Differential voltage <sup>(4)</sup> |              | ±15          | V    |
|                                      | Current <sup>(3)</sup>              |              | ±10          | mA   |
| Output short-circuit <sup>(2)</sup>  |                                     | Continuous   |              |      |
| Operating ambient temperature, $T_A$ |                                     | -55          | 150          | °C   |
| Junction temperature, $T_J$          |                                     |              | 150          | °C   |
| Storage temperature, $T_{stg}$       |                                     | -65          | 150          | °C   |

- Operating the device beyond the ratings listed under *Absolute Maximum Ratings* will cause permanent damage to the device. These are stress ratings only, based on process and design limitations, and this device has not been designed to function outside the conditions indicated under *Recommended Operating Conditions*. Exposure to any condition outside *Recommended Operating Conditions* for extended periods, including absolute-maximum-rated conditions, may affect device reliability and performance.
- Short-circuit to ground, one amplifier per package. Extended short-circuit current, especially with higher supply voltage, can cause excessive heating and eventual destruction.
- Input pins are diode-clamped to the power-supply rails. Input signals that may swing more than 0.5 V beyond the supply rails must be current limited to 10 mA or less.
- Input pins are connected by back-to-back diodes for input protection. If the differential input voltage may exceed 0.5 V, limit the input current to 10mA or less.

### 5.2 ESD Ratings

|             |                         |   | VALUE | UNIT |
|-------------|-------------------------|---|-------|------|
| $V_{(ESD)}$ | Electrostatic discharge | Human-body model (HBM), per ANSI/ESDA/JEDEC JS-001 <sup>(1)</sup>     | ±4000 | V    |
|             |                         | Charged-device model (CDM), per ANSI/ESDA/JEDEC JS-002 <sup>(2)</sup> | ±1500 |      |

- JEDEC document JEP155 states that 500-V HBM allows safe manufacturing with a standard ESD control process.
- JEDEC document JEP157 states that 250-V CDM allows safe manufacturing with a standard ESD control process.

### 5.3 Recommended Operating Conditions

over operating ambient temperature range (unless otherwise noted)

|       |                               | MIN          | MAX          | UNIT |
|-------|-------------------------------|--------------|--------------|------|
| $V_S$ | Supply voltage, $(V+) - (V-)$ | 2.7          | 32           | V    |
| $V_I$ | Common mode voltage range     | $(V-) - 0.1$ | $(V+) + 0.1$ | V    |
| $T_A$ | Specified temperature         | -40          | 125          | °C   |

## 5.4 Thermal Information OPA2993

| THERMAL METRIC <sup>(1)</sup> |  | OPA2993  |      |
|-------------------------------|--|----------|------|
|                               |  | D (SOIC) |      |
|                               |  | 8 PINS   |      |
|                               |  |          | UNIT |
| $R_{\theta JA}$               | Junction-to-ambient thermal resistance       | 127.10   | °C/W |
| $R_{\theta JC(top)}$          | Junction-to-case (top) thermal resistance    | 63.27    | °C/W |
| $R_{\theta JB}$               | Junction-to-board thermal resistance         | 71.20    | °C/W |
| $\Psi_{JT}$                   | Junction-to-top characterization parameter   | 13.91    | °C/W |
| $\Psi_{JB}$                   | Junction-to-board characterization parameter | 70.54    | °C/W |

(1) For more information about traditional and new thermal metrics, see the *Semiconductor and IC Package Thermal Metrics* application report, [SPRA953](#).

## 5.5 Electrical Characteristics

For  $V_S = (V+) - (V-) = 2.7V$  to  $32V$  ( $\pm 0.9V$  to  $\pm 16V$ ) at  $T_A = 25^\circ C$ ,  $R_L = 10k\Omega$  connected to  $V_S / 2$ ,  $V_{CM} = V_S / 2$ , and  $V_{OUT} = V_S / 2$ , unless otherwise noted.

| PARAMETER                                      |  | TEST CONDITIONS   |                                      | MIN          | TYP               | MAX             | UNIT             |  |
|--|--|---|--------------------------------------|--------------|-------------------|-----------------|------------------|--|
| <b>OFFSET VOLTAGE</b>                          |  |   |                                      |              |                   |                 |                  |  |
| $V_{OS}$                                       | Input offset voltage                     | $V_S = 5V$ to $32V$                                       | $T_A = -40^\circ C$ to $125^\circ C$ |              | $\pm 0.25$        | $\pm 1$         | mV               |  |
|  |  |   |                                      |              |                   | $\pm 2$         |                  |  |
|  |  | $V_{CM} = (V-)$   | $T_A = -40^\circ C$ to $125^\circ C$ |              | $\pm 0.2$         | $\pm 0.7$       |                  |  |
|  |  |   |                                      |              |                   | $\pm 0.8$       |                  |  |
|  |  | $V_{CM} = (V+) - 1.35V$                                   | $T_A = -40^\circ C$ to $125^\circ C$ |              | $\pm 1.2$         | $\pm 1.8$       |                  |  |
|  |  |   |                                      |              |                   | $\pm 4$         |                  |  |
| $dV_{OS}/dT$                                   | Input offset voltage drift               | $T_A = -40^\circ C$ to $125^\circ C$                      | $V_{CM} = (V-)$                      |              | $\pm 0.7$         | $\pm 3^{(1)}$   | $\mu V/^\circ C$ |  |
|  |  |   |                                      |              | $\pm 0.5$         | $\pm 3^{(1)}$   |                  |  |
|  |  |   | $V_{CM} = (V+) - 1.35V$              |              | $\pm 0.5$         | $\pm 3.5^{(1)}$ |                  |  |
| PSRR   | Input offset voltage versus power supply | $V_{CM} = (V-)$ ,<br>$T_A = -40^\circ C$ to $125^\circ C$ | $V_S = 5V$ to $32V$                  |              | $\pm 5$           | $\pm 25$        | $\mu V/V$        |  |
|  |  |   |                                      |              | 92                | 106             | dB               |  |
|  |  |   | $V_S = 2.7V$ to $32V$                |              |                   | $\pm 50^{(1)}$  | $\mu V/V$        |  |
|  |  |   |                                      |              | 86 <sup>(1)</sup> |                 | dB               |  |
| <b>INPUT BIAS CURRENT</b>                      |  |   |                                      |              |                   |                 |                  |  |
| $I_B$  | Input bias current                       |   |                                      |              | $\pm 150$         | $\pm 250$       | nA               |  |
|  |  | $T_A = -40^\circ C$ to $85^\circ C$                       |                                      |              |                   | $\pm 320$       |                  |  |
|  |  | $T_A = -40^\circ C$ to $125^\circ C$                      |                                      |              |                   | $\pm 403$       |                  |  |
| $I_{OS}$                                       | Input offset current                     |   |                                      |              | $\pm 0.2$         | $\pm 10$        |                  |  |
|  |  | $T_A = -40^\circ C$ to $125^\circ C$                      |                                      |              |                   | $\pm 15$        |                  |  |
| <b>INPUT VOLTAGE</b>                           |  |   |                                      |              |                   |                 |                  |  |
| $V_{CM}$                                       | Common-mode input voltage range          |   |                                      | $(V-) - 0.1$ |                   | $(V+) + 0.1$    | V                |  |
| CMRR   | Common-mode rejection ratio              | $V_S = 32V$ ,<br>$(V-) < V_{CM} < (V+) - 2V$              | $T_A = -40^\circ C$ to $125^\circ C$ | 100          | 130               |                 | dB               |  |
|  |  |   |                                      | 100          | 125               |                 |                  |  |
|  |  | $V_S = 32V$ ,<br>$(V-) < V_{CM} < (V+) - 1V^{(1)}$        | $T_A = -40^\circ C$ to $125^\circ C$ | 105          | 120               |                 |                  |  |
|  |  |   |                                      | 100          | 115               |                 |                  |  |
|  |  | $V_S = 5V$ ,<br>$(V-) < V_{CM} < (V+) - 2V$               | $T_A = -40^\circ C$ to $125^\circ C$ | 100          | 120               |                 |                  |  |
|  |  |   |                                      | 95           | 105               |                 |                  |  |
|  |  | $V_S = 5V$ ,<br>$(V-) < V_{CM} < (V+) - 1V^{(1)}$         | $T_A = -40^\circ C$ to $125^\circ C$ | 90           | 100               |                 |                  |  |
|  |  |   |                                      | 86           | 95                |                 |                  |  |
|  |  | $V_S = 2.7V$ ,<br>$(V-) < V_{CM} < (V+) - 2V^{(1)}$       | $T_A = -40^\circ C$ to $125^\circ C$ | 90           | 98                |                 |                  |  |
|  |  |   |                                      | 88           | 95                |                 |                  |  |
|  |  | $V_S = 2.7V$ ,<br>$(V-) < V_{CM} < (V+) - 1V^{(1)}$       | $T_A = -40^\circ C$ to $125^\circ C$ | 77           | 90                |                 |                  |  |
|  |  |   |                                      | 72           | 86                |                 |                  |  |
|  |  | $V_S = 32V$ ,<br>$(V-) < V_{CM} < (V+)$                   | $T_A = -40^\circ C$ to $125^\circ C$ | 83           | 95                |                 |                  |  |
|  |  |   |                                      | 81           | 91                |                 |                  |  |
| $V_S = 5V$ ,<br>$(V-) < V_{CM} < (V+)$         | $T_A = -40^\circ C$ to $125^\circ C$     | 68  | 83                                   |              |                   |                 |                  |  |
|  |  | 65  | 80                                   |              |                   |                 |                  |  |
| $V_S = 2.7V$ ,<br>$(V-) < V_{CM} < (V+)^{(1)}$ | $T_A = -40^\circ C$ to $125^\circ C$     | 64  | 79                                   |              |                   |                 |                  |  |
|  |  | 59  | 75                                   |              |                   |                 |                  |  |
|  | $(V+) - 2V < V_{CM} < (V+) - 1V$         |   |                                      |              |                   |                 |                  |  |
| <b>INPUT IMPEDANCE</b>                         |  |   |                                      |              |                   |                 |                  |  |
| $Z_{ID}$                                       | Differential                             |   |                                      |              | 1.1    1          |                 | M $\Omega$    pF |  |
| $Z_{ICM}$                                      | Common-mode                              |   |                                      |              | 3.8    1.8        |                 | G $\Omega$    pF |  |

## 5.5 Electrical Characteristics (continued)

For  $V_S = (V+) - (V-) = 2.7V$  to  $32V$  ( $\pm 0.9V$  to  $\pm 16V$ ) at  $T_A = 25^\circ C$ ,  $R_L = 10k\Omega$  connected to  $V_S / 2$ ,  $V_{CM} = V_S / 2$ , and  $V_{OUT} = V_S / 2$ , unless otherwise noted.

| PARAMETER   |                                      | TEST CONDITIONS   |                                      | MIN | TYP     | MAX | UNIT           |
|---|--------------------------------------|---|--------------------------------------|-----|---------|-----|----------------|
| <b>OPEN-LOOP GAIN</b>   |                                      |   |                                      |     |         |     |                |
| $A_{OL}$  | Open-loop voltage gain               | $V_S = 32V$ ,<br>$(V-) + 1V < V_O < (V+) - 1V$                            | $T_A = -40^\circ C$ to $125^\circ C$ | 110 | 136     |     | dB             |
|   |                                      |   |                                      | 92  |         |     |                |
|   |                                      | $V_S = 5V$ ,<br>$(V-) + 1V < V_O < (V+) - 1V^{(1)}$                       | $T_A = -40^\circ C$ to $125^\circ C$ | 100 | 130     |     |                |
|   |                                      |   |                                      | 91  | 97      |     |                |
| $V_S = 2.7V$ ,<br>$(V-) + 1V < V_O < (V+) - 1V^{(1)}$                   | $T_A = -40^\circ C$ to $125^\circ C$ | 108   | 126                                  |     |         |     |                |
|   |                                      | 85  |                                      |     |         |     |                |
| <b>NOISE</b>  |                                      |   |                                      |     |         |     |                |
| $E_N$   | Input voltage noise                  | $f = 0.1Hz$ to $10Hz$   |                                      |     | 0.5     |     | $\mu V_{PP}$   |
|   |                                      |   |                                      |     | 0.08    |     | $\mu V_{RMS}$  |
| $e_N$   | Input voltage noise density          | $f = 1kHz$  |                                      |     | 13      |     | $nV/\sqrt{Hz}$ |
|   |                                      | $f = 10kHz$   |                                      |     | 13      |     |                |
| $i_N$   | Input current noise density          | $f = 1kHz$  |                                      |     | 0.17    |     | $pA/\sqrt{Hz}$ |
| <b>FREQUENCY RESPONSE</b>   |                                      |   |                                      |     |         |     |                |
| $f_U$   | Unity-gain bandwidth                 | $R_L = 1M\Omega$  |                                      |     | 8       |     | MHz            |
| GBW   | Gain-bandwidth product               | $f = 1kHz$ to $100kHz$  |                                      |     | 20      |     | MHz            |
| SR  | Slew rate                            | $V_S = 32V$ , $V_{STEP} = 10V$ , $R_S < 1k\Omega$ , $C_L = 20pF$          |                                      |     | 40      |     | V/ $\mu s$     |
| $t_S$   | Settling time                        | To 0.1%, $V_S = 32V$ , $V_{STEP} = 10V$ , $G = +1$ , $C_L = 20pF$         |                                      |     | 0.74    |     | $\mu s$        |
|   |                                      | To 0.01%, $V_S = 32V$ , $V_{STEP} = 10V$ , $G = +1$ , $C_L = 20pF$        |                                      |     | 1       |     |                |
| PM  | Phase margin                         | $G = +1$ , $R_L = 10k\Omega$ , $C_L = 20pF$                               |                                      |     | 60      |     | $^\circ$       |
| GM  | Gain margin                          | $G = +1$ , $R_L = 10k\Omega$ , $C_L = 20pF$                               |                                      |     | 12      |     | dB             |
| $t_{OR}$  | Overload recovery time               | $V_{IN} \times gain > V_S$  |                                      |     | 408     |     | ns             |
| THD+N   | Total harmonic distortion + noise    | $V_S = 32V$ , $V_O = 3V_{RMS}$ , $G = 1$ , $f = 1kHz$ , $R_L = 10k\Omega$ |                                      |     | 0.00014 |     | %              |
|   |                                      |   |                                      |     | 117     |     | dB             |
| <b>OUTPUT</b>   |                                      |   |                                      |     |         |     |                |
|   | Voltage output swing from rail       | $V_S = 32V$ ,<br>Positive and negative rail headroom, $R_L = no\ load$    | $T_A = -40^\circ C$ to $125^\circ C$ |     | 40      | 140 | mV             |
|   |                                      |   |                                      |     |         | 140 |                |
|   |                                      | $V_S = 32V$ ,<br>Positive and negative rail headroom                      | $T_A = -40^\circ C$ to $125^\circ C$ |     | 93      | 127 |                |
|   |                                      |   |                                      |     |         | 185 |                |
|   |                                      | $V_S = 5V$ ,<br>Positive and negative rail headroom, $R_L = no\ load$     | $T_A = -40^\circ C$ to $125^\circ C$ |     | 27      | 60  |                |
|   |                                      |   |                                      |     | 52      | 71  |                |
|   |                                      | $V_S = 5V$ ,<br>Positive and negative rail headroom                       | $T_A = -40^\circ C$ to $125^\circ C$ |     |         | 90  |                |
|   |                                      |   |                                      |     | 86      | 118 |                |
|   |                                      | $V_S = 2.7V$ ,<br>Positive and negative rail headroom, $R_L = 2k\Omega$   | $T_A = -40^\circ C$ to $125^\circ C$ |     |         | 133 |                |
|   |                                      |   | 31                                   | 94  |         |     |                |
| $V_S = 2.7V$ ,<br>Positive and negative rail headroom, $R_L = no\ load$ | $T_A = -40^\circ C$ to $125^\circ C$ |   |                                      | 112 |         |     |                |
|   |                                      |   | 54                                   | 84  |         |     |                |
| $V_S = 2.7V$ ,<br>Positive and negative rail headroom                   | $T_A = -40^\circ C$ to $125^\circ C$ |   |                                      | 115 |         |     |                |
|   |                                      |   | 85                                   | 136 |         |     |                |
| $V_S = 2.7V$ ,<br>Positive and negative rail headroom, $R_L = 2k\Omega$ | $T_A = -40^\circ C$ to $125^\circ C$ |   |                                      | 150 |         |     |                |
|   |                                      |   |                                      |     |         |     |                |

## 5.5 Electrical Characteristics (continued)

For  $V_S = (V+) - (V-) = 2.7V$  to  $32V$  ( $\pm 0.9V$  to  $\pm 16V$ ) at  $T_A = 25^\circ C$ ,  $R_L = 10k\Omega$  connected to  $V_S / 2$ ,  $V_{CM} = V_S / 2$ , and  $V_{OUT} = V_S / 2$ , unless otherwise noted.

| PARAMETER           |                                 | TEST CONDITIONS        |                                      | MIN | TYP      | MAX      | UNIT     |          |          |    |
|---------------------|---------------------------------|------------------------|--------------------------------------|-----|----------|----------|----------|----------|----------|----|
| $I_{SC}$            | Short-circuit current           | $V_S = 32V$            |                                      |     | $\pm 40$ | $\pm 80$ | mA       |          |          |    |
|                     |                                 |                        | $T_A = -40^\circ C$ to $125^\circ C$ |     |          |          |          | $\pm 70$ |          |    |
|                     |                                 | $V_S = 5V^{(1)}$       |                                      |     |          | $\pm 30$ |          | $\pm 60$ | mA       |    |
|                     |                                 |                        | $T_A = -40^\circ C$ to $125^\circ C$ |     |          |          |          | $\pm 60$ |          |    |
|                     |                                 | $V_S = 2.7V^{(1)}$     |                                      |     |          |          |          | $\pm 8$  | $\pm 16$ | mA |
|                     |                                 |                        | $T_A = -40^\circ C$ to $125^\circ C$ |     |          |          |          |          | $\pm 16$ |    |
| $C_{LOAD}$          | Capacitive load drive           |                        |                                      |     |          |          | pF       |          |          |    |
| $Z_O$               | Open-loop output impedance      | $I_O = 0A$             |                                      |     |          |          | $\Omega$ |          |          |    |
| <b>POWER SUPPLY</b> |                                 |                        |                                      |     |          |          |          |          |          |    |
| $I_Q$               | Quiescent current per amplifier | $V_S = 32V, I_O = 0A$  |                                      |     | 400      | 560      | $\mu A$  |          |          |    |
|                     |                                 |                        | $T_A = -40^\circ C$ to $125^\circ C$ |     |          |          |          | 560      |          |    |
|                     |                                 | $V_S = 5V, I_O = 0A$   |                                      |     |          | 390      |          | 500      | mA       |    |
|                     |                                 |                        | $T_A = -40^\circ C$ to $125^\circ C$ |     |          |          |          | 500      |          |    |
|                     |                                 | $V_S = 2.7V, I_O = 0A$ |                                      |     |          | 350      |          | 500      | mA       |    |
|                     |                                 |                        | $T_A = -40^\circ C$ to $125^\circ C$ |     |          |          |          | 500      |          |    |

(1) Specified by characterization only.

## 5.6 Typical Characteristics

at  $T_A = 25^\circ\text{C}$ ,  $V_S = \pm 16\text{V}$ ,  $V_{CM} = V_S / 2$ ,  $R_{LOAD} = 10\text{k}\Omega$  (unless otherwise noted)

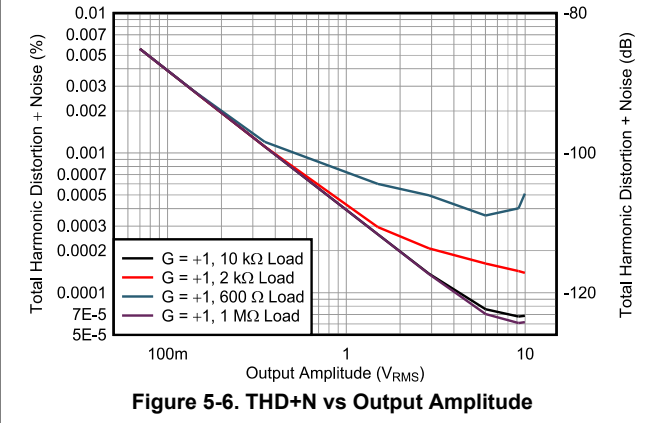
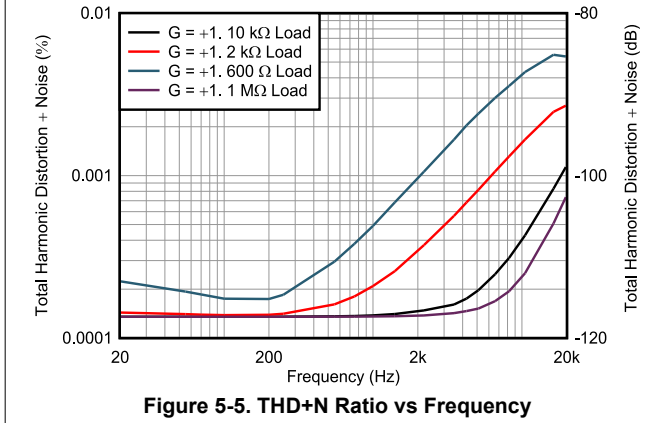
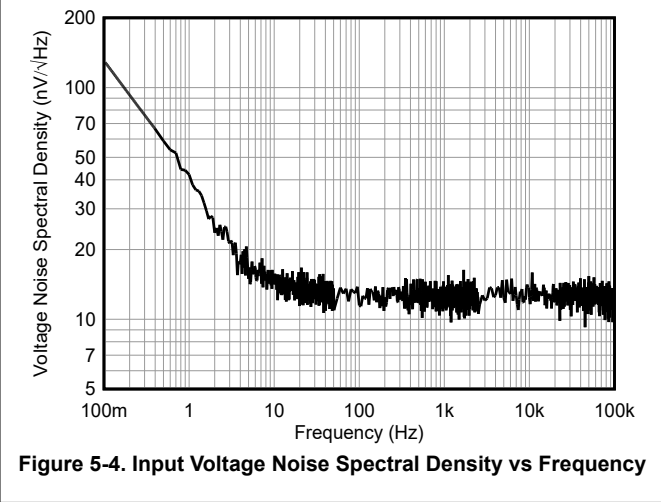
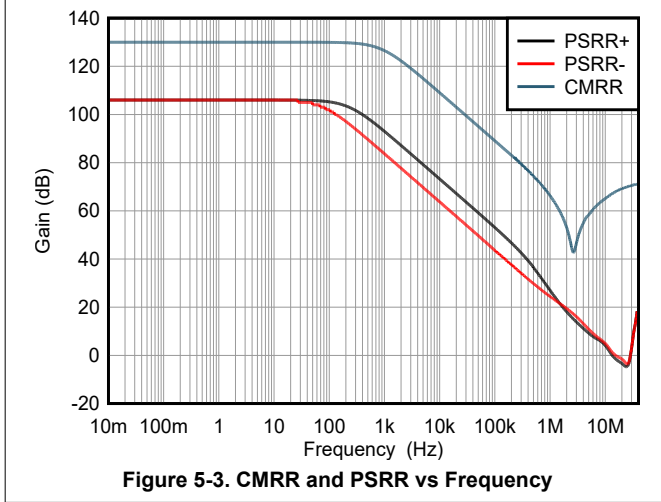
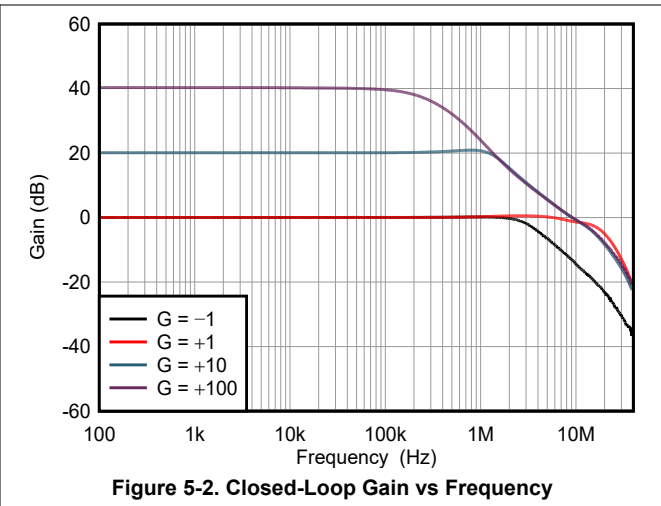
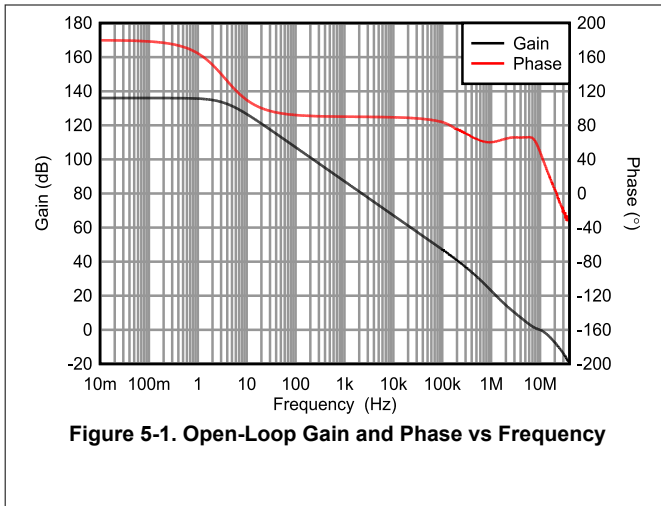

## 5.6 Typical Characteristics (continued)

at  $T_A = 25^\circ\text{C}$ ,  $V_S = \pm 16\text{V}$ ,  $V_{CM} = V_S / 2$ ,  $R_{LOAD} = 10\text{k}\Omega$  (unless otherwise noted)

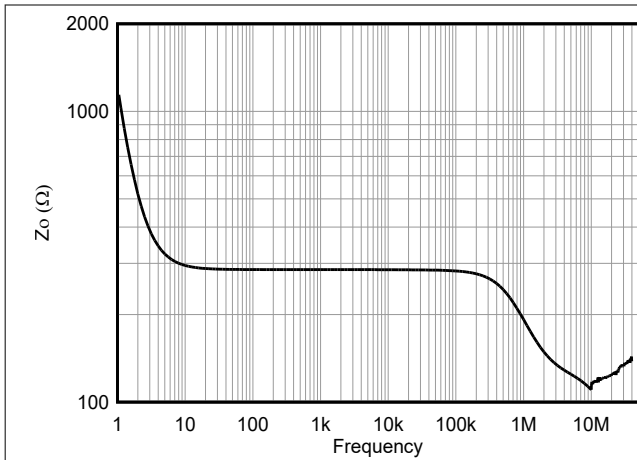

Figure 5-7. Open-Loop Output Impedance vs Frequency

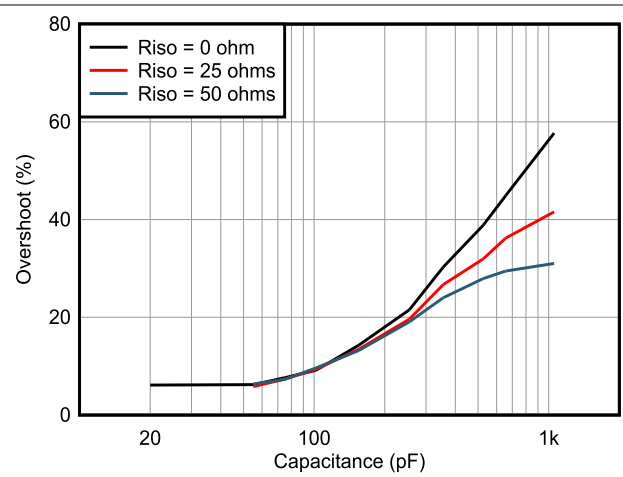

Figure 5-8. Small-Signal Overshoot vs Capacitive Load

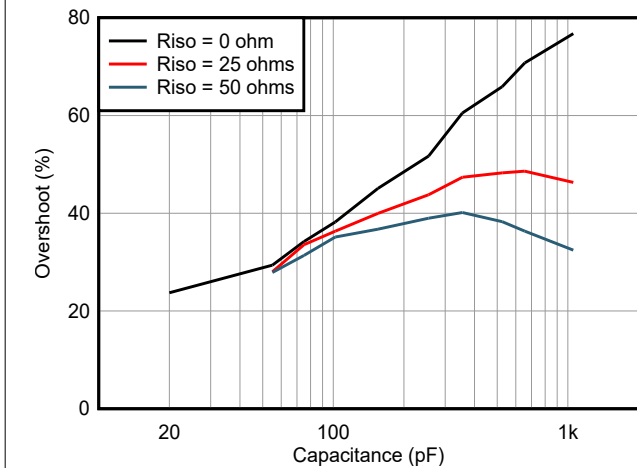

Figure 5-9. Small-Signal Overshoot vs Capacitive Load

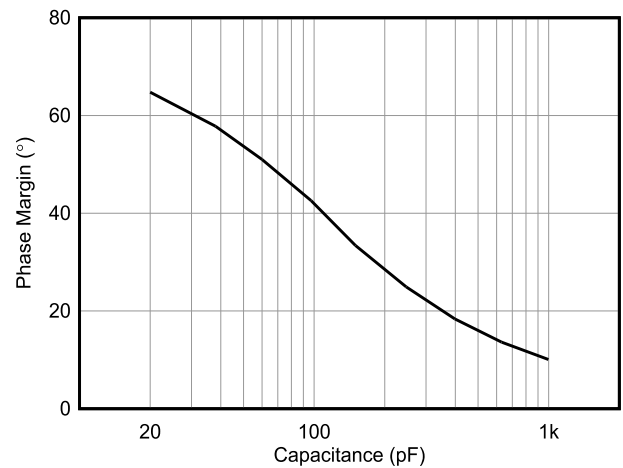

Figure 5-10. Phase Margin vs Capacitive Load

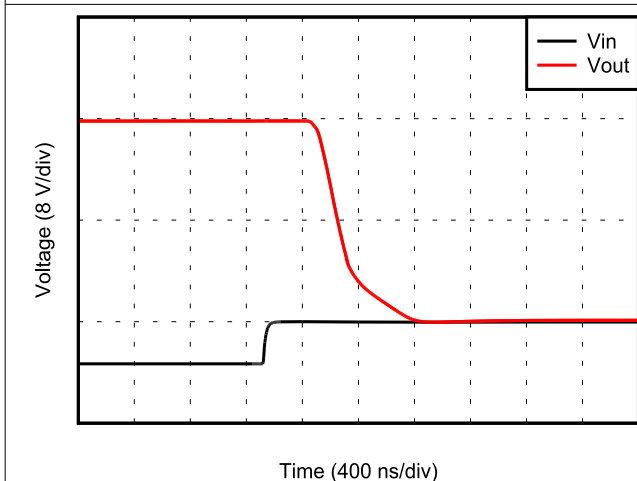

Figure 5-11. Positive Overload Recovery

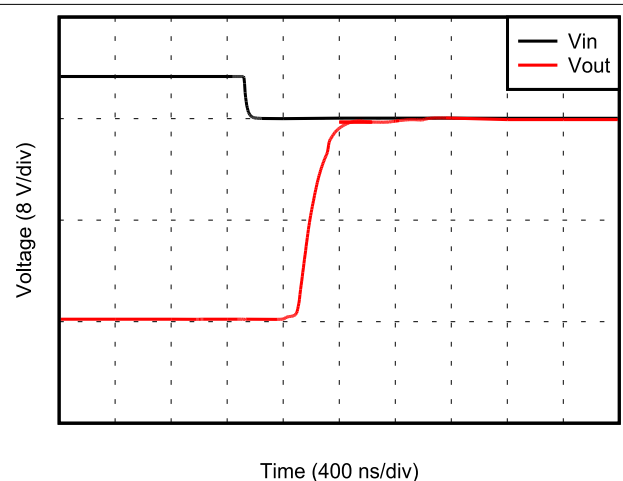

Figure 5-12. Negative Overload Recovery

## 5.6 Typical Characteristics (continued)

at  $T_A = 25^\circ\text{C}$ ,  $V_S = \pm 16\text{V}$ ,  $V_{CM} = V_S / 2$ ,  $R_{LOAD} = 10\text{k}\Omega$  (unless otherwise noted)

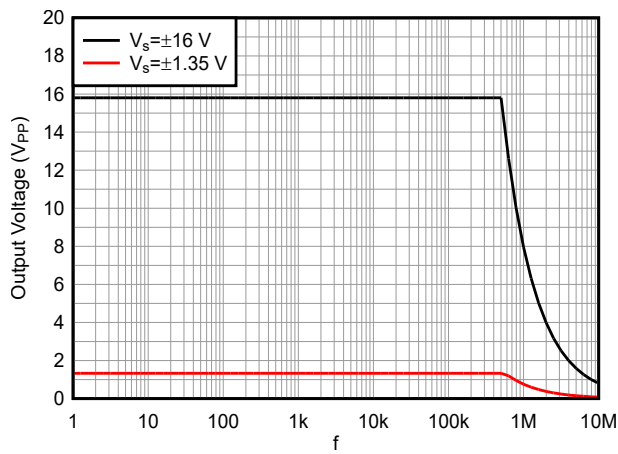

Figure 5-13. Maximum Output Voltage vs Frequency

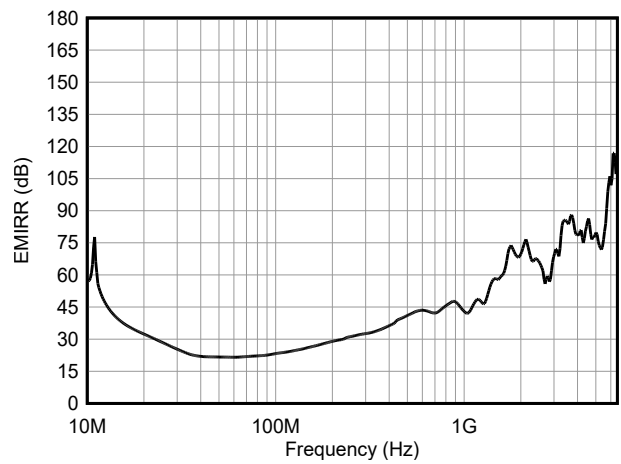

Figure 5-14. EMIRR (Electromagnetic Interference Rejection Ratio) vs Frequency

## 6 Detailed Description

### 6.1 Overview

The OPAx993 family (OPA2993 and OPA4993) is a family of high voltage (32V) general purpose operational amplifiers.

The OPAx993 family has a wide gain bandwidth of 20MHz and fast slew rate of 40V/μs when no capacitive load is present. These devices require 400uA (typical) at most.

These devices also offer excellent DC precision, including rail-to-rail input/output, low offset (±250μV, typical), and low offset drift (±0.5μV/°C, typical).

### 6.2 Functional Block Diagram

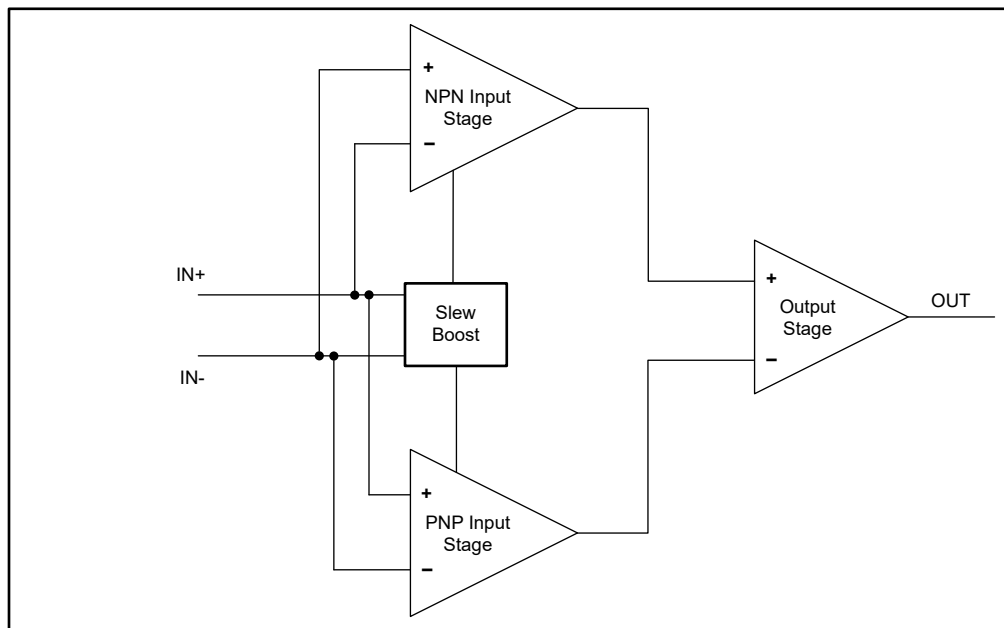

### 6.3 Feature Description

#### 6.3.1 Noise Performance

The equation [Equation 1](#) shows the total circuit noise for varying source impedances with the operational amplifier in a unity-gain configuration (no feedback resistor network; therefore, no additional noise contributions).

$$E_0^2 = e_n^2 + (i_n R_S)^2 + 4kTR_S \quad (1)$$

The OPAx993 has very low voltage noise, making this device an excellent choice for low source impedances (less than 20kΩ). A similar precision operational amplifier, the [OPAx994](#), has somewhat lower voltage noise but higher current noise. The OPAx993 provides excellent noise performance at moderate source impedance (10kΩ to 100kΩ). Above 100kΩ, a FET-input operational amplifier such as the [OPA2156](#) (very low current noise) can provide improved performance. Use the equation [Equation 1](#) to calculate the total circuit noise, where  $e_n$  = voltage noise,  $i_n$  = current noise,  $R_S$  = source impedance,  $k$  = Boltzmann's constant =  $1.38 \times 10^{-23}$  J/K, and  $T$  is temperature in K.

### 6.3.2 Common-Mode Voltage Range

The OPAx993 is a 32V, true rail-to-rail input operational amplifier with an input common-mode range that extends to both supply rails. This wide range is achieved with paralleled complementary PNP and NPN differential input pairs, as shown in [Figure 6-1](#). The NPN pair is active for input voltages close to the positive rail, typically from  $(V+) - 1V$  to the positive supply. The PNP pair is active for inputs from the negative supply to approximately  $(V+) - 2V$ . There is a small transition region, typically  $(V+) - 2V$  to  $(V+) - 1V$ , in which both input pairs are on. This transition region can vary modestly with process variation. Within this region PSRR, CMRR, offset voltage, offset drift, noise, and THD performance can be degraded compared to operation outside this region.

For more information on common-mode voltage range and complementary pair interaction, see [Op Amps With Complementary-Pair Input Stages](#) application note.

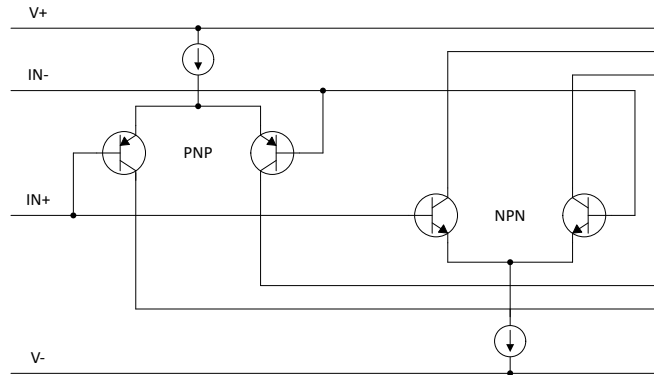

**Figure 6-1. Rail-to-Rail Input Stage**

### 6.3.3 Phase Reversal Protection

The OPAx993 family has internal phase-reversal protection. Many op amps exhibit a phase reversal when the input is driven beyond the linear common-mode range. This condition is most often encountered in non-inverting circuits when the input is driven beyond the specified common-mode voltage range, causing the output to reverse into the opposite rail. The OPAx993 is a rail-to-rail input op amp; therefore, the common-mode range can extend up to the rails. Input signals beyond the rails do not cause phase reversal; instead, the output limits into the appropriate rail. This performance is shown in [Figure 6-2](#). For more information on phase reversal, see [Op Amps With Complementary-Pair Input Stages](#) application note.

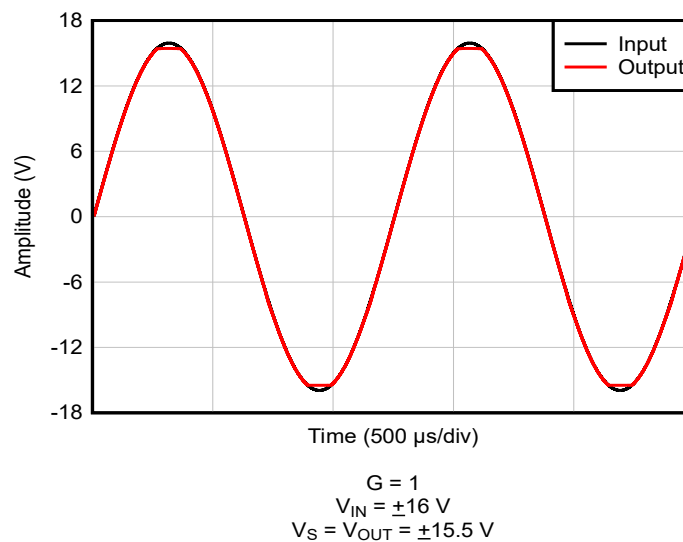

**Figure 6-2. No Phase Reversal**

### 6.3.4 Overload Recovery

Overload recovery is defined as the time required for the op amp output to recover from a saturated state to a linear state. The output devices of the op amp enter a saturation region when the output voltage exceeds the rated operating voltage, either due to the high input voltage or the high gain. After the device enters the saturation region, the charge carriers in the output devices require time to return back to the linear state. After the charge carriers return back to the linear state, the device begins to slew at the specified slew rate. Thus, the propagation delay in case of an overload condition is the sum of the overload recovery time and the slew time. The overload recovery time for the OPAx993 is approximately 408ns.

### 6.3.5 Electrical Overstress

Designers often ask questions about the capability of an operational amplifier to withstand electrical overstress (EOS). These questions tend to focus on the device inputs, but can involve the supply voltage pins or even the output pin. Each of these different pin functions have electrical stress limits determined by the voltage breakdown characteristics of the particular semiconductor fabrication process and specific circuits connected to the pin. Additionally, internal electrostatic discharge (ESD) protection is built into these circuits to protect them from accidental ESD events both before and during product assembly.

Having a good understanding of this basic ESD circuitry and the relevance to an electrical overstress event is helpful. Figure 6-3 shows an illustration of the ESD circuits contained in the OPAx993 (indicated by the dashed line area). The ESD protection circuitry involves several current-steering diodes connected from the input and output pins and routed back to the internal power-supply lines, where the diodes meet at an absorption device or the power-supply ESD cell, internal to the operational amplifier. This protection circuitry is intended to remain inactive during normal circuit operation.

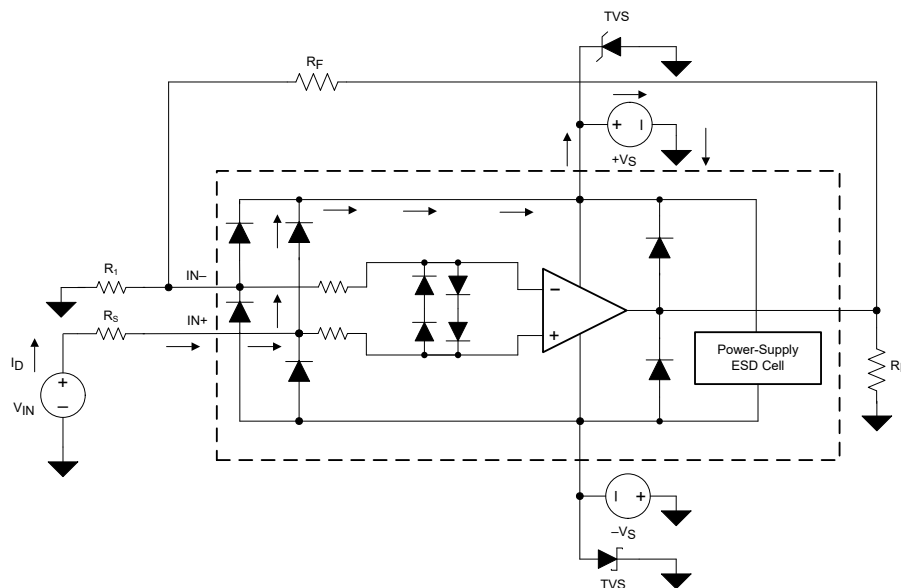

Figure 6-3. Equivalent Internal ESD Circuitry Relative to a Typical Circuit Application

An ESD event produces a short-duration, high-voltage pulse that is transformed into a short-duration, high-current pulse while discharging through a semiconductor device. The ESD protection circuits are designed to provide a current path around the operational amplifier core to prevent damage. The energy absorbed by the protection circuitry is then dissipated as heat.

When an ESD voltage develops across two or more amplifier device terminals, current flows through one or more steering diodes. Depending on the path that the current takes, the absorption device can activate. The absorption device has a trigger, or threshold voltage, that is above the normal operating voltage of the OPAx993 but below the device breakdown voltage level. When this threshold is exceeded, the absorption device quickly activates and clamps the voltage across the supply rails to a safe level.

When the operational amplifier connects into a circuit (as shown in [Figure 6-3](#)), the ESD protection components are intended to remain inactive and do not become involved in the application circuit operation. However, circumstances can arise where an applied voltage exceeds the operating voltage range of a given terminal. If this condition occurs, there is a risk that some internal ESD protection circuits can turn on and conduct current. Any such current flow occurs through steering-diode paths and rarely involves the absorption device.

[Figure 6-3](#) shows a specific example where the input voltage ( $V_{IN}$ ) exceeds the positive supply voltage ( $+V_S$ ) by 500mV or more. Much of what happens in the circuit depends on the supply characteristics. If  $+V_S$  can sink the current, one of the upper input steering diodes conducts and directs current to  $+V_S$ . Excessively high current levels can flow with increasingly higher  $V_{IN}$ . As a result, the data sheet specifications recommend that applications limit the input current to 10mA.

If the supply is not capable of sinking the current,  $V_{IN}$  can begin sourcing current to the operational amplifier, and then take over as the source of positive supply voltage. The danger in this case is that the voltage can rise to levels that exceed the operational amplifier absolute maximum ratings.

Another common question involves what happens to the amplifier if an input signal is applied to the input while the power supplies  $+V_S$  or  $-V_S$  are at 0V. Again, this question depends on the supply characteristic while at 0V, or at a level below the input-signal amplitude. If the supplies appear as high impedance, then the input source supplies the operational amplifier current through the current-steering diodes. This state is not a normal bias condition; most likely, the amplifier does not operate normally. If the supplies are low impedance, then the current through the steering diodes can become quite high. The current level depends on the ability of the input source to deliver current, and any resistance in the input path.

If there is any uncertainty about the ability of the supply to absorb this current, add external Zener diodes to the supply terminals; see [Figure 6-3](#). Select the Zener voltage so that the diode does not turn on during normal operation. However, the Zener voltage must be low enough so that the Zener diode conducts if the supply terminal begins to rise above the safe-operating, supply-voltage level.

The OPAx993 input terminals are protected from excessive differential voltage with back-to-back diodes; see [Figure 6-3](#). In most circuit applications, the input protection circuitry has no effect. However, in low-gain or  $G = 1$  circuits, fast-ramping input signals can forward-bias these diodes because the output of the amplifier cannot respond rapidly enough to the input ramp. If the input signal is fast enough to create this forward-bias condition, limit the input signal current to 10mA or less. If the input signal current is not inherently limited, an input series resistor can be used to limit the input signal current. This input series resistor degrades the low-noise performance of the OPAx993. [Figure 6-3](#) shows an example configuration that implements a current-limiting feedback resistor.

## 6.4 Device Functional Modes

The OPAx993 has a single functional mode and is operational when the power-supply voltage is greater than or equal to 2.7V ( $\pm 1.35V$ ). The maximum power supply voltage for the OPAx993 is 32V ( $\pm 16V$ ).

## 7 Application and Implementation

### Note

Information in the following applications sections is not part of the TI component specification, and TI does not warrant its accuracy or completeness. TI's customers are responsible for determining suitability of components for their purposes, as well as validating and testing their design implementation to confirm system functionality.

### 7.1 Application Information

The OPAX993 family offers excellent DC precision and AC performance. These devices operate up to 32V supply rails and offer true rail-to-rail input/output, low offset voltage and offset voltage drift, as well as 20MHz bandwidth and high slew rate. These features make the OPAX993 a robust, high-performance operational amplifier for high-voltage industrial applications.

### 7.2 Typical Applications

#### 7.2.1 Low-Side Current Measurement

Figure 7-1 shows the OPAX993 configured in a low-side current sensing application. For a full analysis of the circuit shown in Figure 7-1 including theory, calculations, simulations, and measured data, see TI Precision Design TIPD129, *0A to 1A Single-Supply Low-Side Current-Sensing Solution*.

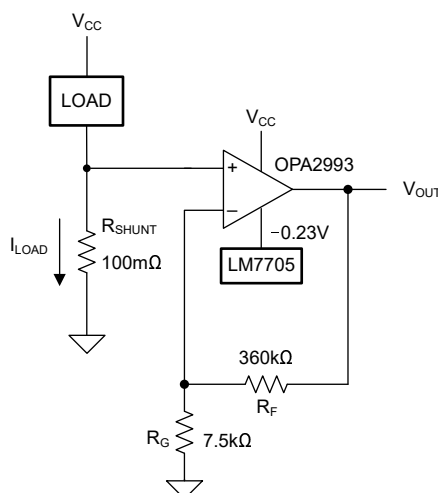

Figure 7-1. OPAX993 in a Low-Side, Current-Sensing Application

#### 7.2.1.1 Design Requirements

The design requirements for this design are as follows:

- Load current: 0A to 1A
- Max output voltage: 4.9V
- Maximum shunt voltage: 100mV

#### 7.2.1.2 Detailed Design Procedure

The transfer function of the circuit in Figure 7-1 is given in Equation 2:

$$V_{OUT} = I_{LOAD} \times R_{SHUNT} \times \text{Gain} \quad (2)$$

The load current ( $I_{LOAD}$ ) produces a voltage drop across the shunt resistor ( $R_{SHUNT}$ ). The load current is set from 0A to 1A. To keep the shunt voltage below 100mV at maximum load current, the largest shunt resistor is defined using [Equation 3](#):

$$R_{SHUNT} = \frac{V_{SHUNT\_MAX}}{I_{LOAD\_MAX}} = \frac{100mV}{1A} = 100m\Omega \quad (3)$$

Using [Equation 3](#),  $R_{SHUNT}$  is calculated to be 100mΩ. The voltage drop produced by  $I_{LOAD}$  and  $R_{SHUNT}$  is amplified by the OPAx993 to produce an output voltage of 0V to 4.9V. The gain needed by the OPAx993 to produce the necessary output voltage is calculated using [Equation 4](#):

$$\text{Gain} = \frac{(V_{OUT\_MAX} - V_{OUT\_MIN})}{(V_{IN\_MAX} - V_{IN\_MIN})} \quad (4)$$

Using [Equation 4](#), the required gain is calculated to be 49V/V, which is set with resistors  $R_F$  and  $R_G$ . [Equation 5](#) is used to size the resistors,  $R_F$  and  $R_G$ , to set the gain of the OPAx993 to 49V/V.

$$\text{Gain} = 1 + \frac{(R_F)}{(R_G)} \quad (5)$$

Choosing  $R_F$  as 5.76kΩ,  $R_G$  is calculated to be 120Ω.  $R_F$  and  $R_G$  were chosen as 5.76kΩ and 120Ω because they are standard value resistors that create a 49:1 ratio. Other resistors that create a 49:1 ratio can also be used. However, excessively large resistors can generate thermal noise that exceeds the intrinsic noise of the op amp. [Figure 7-2](#) shows the measured transfer function of the circuit shown in [Figure 7-1](#).

### 7.2.1.3 Application Curve

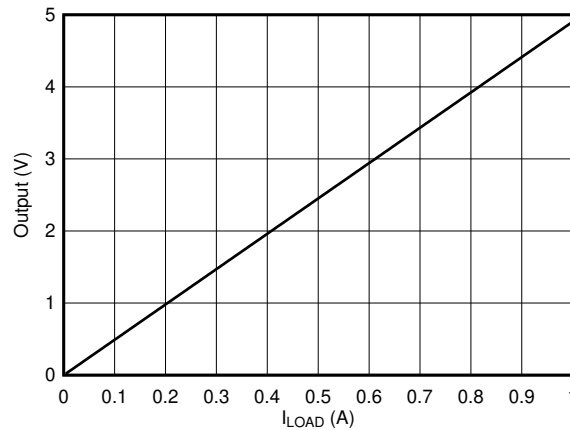

**Figure 7-2. Low-Side, Current-Sense, Transfer Function**

## 7.3 Power Supply Recommendations

The OPAx993 is specified for operation from 2.7V to 32V ( $\pm 1.35V$  to  $\pm 16V$ ); many specifications apply from  $-40^\circ\text{C}$  to  $125^\circ\text{C}$  or with specific supply voltages and test conditions.

**CAUTION**  
Supply voltages larger than 33V can permanently damage the device; see [Section 5.1](#).

Place 0.1μF bypass capacitors close to the power-supply pins to reduce errors coupling in from noisy or high-impedance power supplies. For more detailed information on bypass capacitor placement, refer to [Layout](#).

## 7.4 Layout

### 7.4.1 Layout Guidelines

For best operational performance of the device, use good PCB layout practices, including:

- Noise can propagate into analog circuitry through the power pins of the circuit as a whole and op amp itself. Bypass capacitors are used to reduce the coupled noise by providing low-impedance power sources local to the analog circuitry.
  - Connect low-ESR, 0.1 $\mu$ F ceramic bypass capacitors between each supply pin and ground, placed as close to the device as possible. A single bypass capacitor from V+ to ground is applicable for single-supply applications.
- Separate grounding for analog and digital portions of circuitry is one of the simplest and most-effective methods of noise suppression. One or more layers on multilayer PCBs are usually devoted to ground planes. A ground plane helps distribute heat and reduces EMI noise pickup. Make sure to physically separate digital and analog grounds paying attention to the flow of the ground current.
- To reduce parasitic coupling, run the input traces as far away from the supply or output traces as possible. If these traces cannot be kept separate, crossing the sensitive trace perpendicular is much better as opposed to in parallel with the noisy trace.
- Place the external components as close to the device as possible, keeping RF and RG close to the inverting input minimizes parasitic capacitance.
- Keep the length of input traces as short as possible. Always remember that the input traces are the most sensitive part of the circuit.
- Consider a driven, low-impedance guard ring around the critical traces. A guard ring can significantly reduce leakage currents from nearby traces that are at different potentials.
- Cleaning the PCB following board assembly is recommended for best performance.
- Any precision integrated circuit can experience performance shifts due to moisture ingress into the plastic package. Following any aqueous PCB cleaning process, baking the PCB assembly is recommended to remove moisture introduced into the device packaging during the cleaning process. A low temperature, post cleaning bake at 85°C for 30 minutes is sufficient for most circumstances.

### 7.4.2 Layout Example

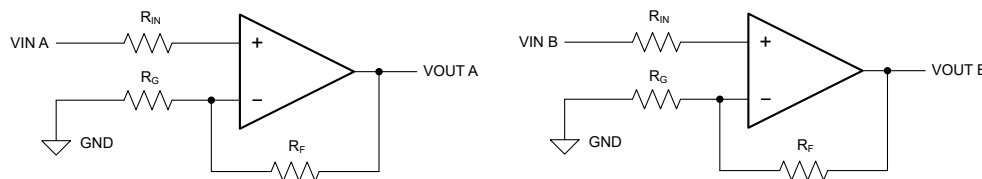

**Figure 7-3. Schematic Representation**

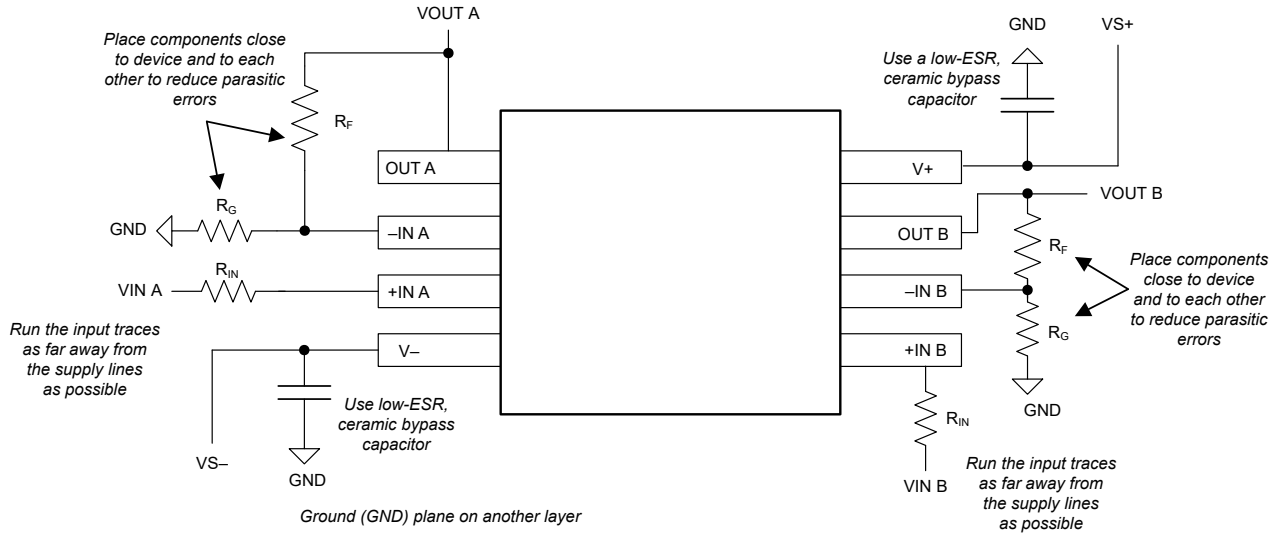

**Figure 7-4. Layout Example**

**Figure 7-5. Schematic for Noninverting Configuration Layout Example**

## 8 Device and Documentation Support

### 8.1 Device Support

#### 8.1.1 Development Support

##### 8.1.1.1 TINA-TI™ (Free Software Download)

TINA™ is a simple, powerful, and easy-to-use circuit simulation program based on a SPICE engine. TINA-TI is a free, fully-functional version of the TINA software, preloaded with a library of macro models in addition to a range of both passive and active models. TINA-TI provides all the conventional dc, transient, and frequency domain analysis of SPICE, as well as additional design capabilities.

Available as a [free download](#) from the Analog eLab Design Center, TINA-TI offers extensive post-processing capability that allows users to format results in a variety of ways. Virtual instruments offer the ability to select input waveforms and probe circuit nodes, voltages, and waveforms, creating a dynamic quick-start tool.

---

#### Note

These files require that either the TINA software (from DesignSoft™) or TINA-TI software be installed. Download the free TINA-TI software from the [TINA-TI folder](#).

---

### 8.2 Documentation Support

#### 8.2.1 Related Documentation

For related documentation, see the following:

- Texas Instruments, [EMI Rejection Ratio of Operational Amplifiers application note](#)
- Texas Instruments, [Op Amps With Complementary-Pair Input Stages application note](#)
- Texas Instruments, [0A to 1A, Single-Supply, Low-Side, Current Sensing Solution design guide](#)

### 8.3 Receiving Notification of Documentation Updates

To receive notification of documentation updates, navigate to the device product folder on [ti.com](#). Click on *Notifications* to register and receive a weekly digest of any product information that has changed. For change details, review the revision history included in any revised document.

### 8.4 Support Resources

[TI E2E™ support forums](#) are an engineer's go-to source for fast, verified answers and design help — straight from the experts. Search existing answers or ask your own question to get the quick design help you need.

Linked content is provided "AS IS" by the respective contributors. They do not constitute TI specifications and do not necessarily reflect TI's views; see TI's [Terms of Use](#).

### 8.5 Trademarks

TINA-TI™ is a trademark of Texas Instruments, Inc and DesignSoft, Inc.

TINA™ and DesignSoft™ are trademarks of DesignSoft, Inc.

TI E2E™ is a trademark of Texas Instruments.

All trademarks are the property of their respective owners.

### 8.6 Electrostatic Discharge Caution



This integrated circuit can be damaged by ESD. Texas Instruments recommends that all integrated circuits be handled with appropriate precautions. Failure to observe proper handling and installation procedures can cause damage.

ESD damage can range from subtle performance degradation to complete device failure. Precision integrated circuits may be more susceptible to damage because very small parametric changes could cause the device not to meet its published specifications.

### 8.7 Glossary

[TI Glossary](#) This glossary lists and explains terms, acronyms, and definitions.

## 9 Revision History

NOTE: Page numbers for previous revisions may differ from page numbers in the current version.

| DATE       | REVISION | NOTES           |
|------------|----------|-----------------|
| April 2026 | *        | Initial Release |

## 10 Mechanical, Packaging, and Orderable Information

The following pages include mechanical, packaging, and orderable information. This information is the most current data available for the designated devices. This data is subject to change without notice and revision of this document. For browser-based versions of this data sheet, refer to the left-hand navigation.

## IMPORTANT NOTICE AND DISCLAIMER

TI PROVIDES TECHNICAL AND RELIABILITY DATA (INCLUDING DATASHEETS), DESIGN RESOURCES (INCLUDING REFERENCE DESIGNS), APPLICATION OR OTHER DESIGN ADVICE, WEB TOOLS, SAFETY INFORMATION, AND OTHER RESOURCES "AS IS" AND WITH ALL FAULTS, AND DISCLAIMS ALL WARRANTIES, EXPRESS AND IMPLIED, INCLUDING WITHOUT LIMITATION ANY IMPLIED WARRANTIES OF MERCHANTABILITY, FITNESS FOR A PARTICULAR PURPOSE OR NON-INFRINGEMENT OF THIRD PARTY INTELLECTUAL PROPERTY RIGHTS.

These resources are intended for skilled developers designing with TI products. You are solely responsible for (1) selecting the appropriate TI products for your application, (2) designing, validating and testing your application, and (3) ensuring your application meets applicable standards, and any other safety, security, regulatory or other requirements.

These resources are subject to change without notice. TI grants you permission to use these resources only for development of an application that uses the TI products described in the resource. Other reproduction and display of these resources is prohibited. No license is granted to any other TI intellectual property right or to any third party intellectual property right. TI disclaims responsibility for, and you fully indemnify TI and its representatives against any claims, damages, costs, losses, and liabilities arising out of your use of these resources.

TI's products are provided subject to [TI's Terms of Sale](#), [TI's General Quality Guidelines](#), or other applicable terms available either on [ti.com](http://ti.com) or provided in conjunction with such TI products. TI's provision of these resources does not expand or otherwise alter TI's applicable warranties or warranty disclaimers for TI products. Unless TI explicitly designates a product as custom or customer-specified, TI products are standard, catalog, general purpose devices.

TI objects to and rejects any additional or different terms you may propose.

Copyright © 2026, Texas Instruments Incorporated

Last updated 10/2025