

# OPAx388 高精度、ゼロ・ドリフト、ゼロ・クロスオーバー、真のレール・ツー・レール 入出力のオペアンプ

## 1 特長

- 非常に小さいオフセット電圧：±0.25μV
- ゼロドリフト：±0.005μV/°C
- ゼロ・クロスオーバー：140dB の CMRR、真の RRIO
- 低ノイズ 7.0nV√Hz (1kHz)
- 1/f ノイズなし：140nV<sub>PP</sub> (0.1Hz ~ 10Hz)
- 高速セトリング：2μs (1V ステップ、0.01% まで)
- ゲイン帯域幅：10MHz
- 単電源：2.5V ~ 5.5V
- デュアル電源：±1.25V ~ ±2.75V
- 真のレール・ツー・レール入出力
- EMI および RFI フィルタ入力
- 業界標準パッケージ
  - シングル：SOIC-8、SOT-23-5、VSSOP-8
  - デュアル：SOIC-8 および VSSOP-8
  - クワッド：SOIC-14 および TSSOP-14

## 2 アプリケーション

- 商用ネットワークとサーバーの PSU (電源)
- ノート PC 向け電源アダプタの設計
- 重量計
- 実験室およびフィールド用計測機器
- バッテリ試験装置
- 電子温度計
- 温度トランスミッタ

## 3 概要

OPAx388 (OPA388, OPA2388, OPA4388) シリーズの高精度オペアンプは、非常にノイズが低く、セトリングが高速な、ゼロ・ドリフト、ゼロ・クロスオーバーのデバイスであり、レール・ツー・レールの入力および出力動作を行います。これらの機能に加え、非常に優れた AC 性能と、わずが 0.25μV のオフセット、温度範囲全体で 0.005μV/°C のドリフト係数により、OPAx388 は高精度のアナログ/デジタル・コンバータ (ADC) の駆動や、高分解能のデジタル/アナログ・コンバータ (DAC) の出力のバッファリングに理想的です。この設計により、アナログ/デジタル・コンバータ (ADC) の駆動時に直線性の低下がなく、優れた性能を発揮します。OPA388 (シングル・バージョン) は VSSOP-8、SOT23-5、SOIC-8 パッケージで供給されます。OPA2388 (デュアル・バージョン) は VSSOP-8 および SO-8 パッケージで供給されます。OPA4388 (クワッド・バージョン) は TSSOP-14 および SO-14 パッケージで供給されます。すべてのバージョンは産業用温度範囲 (-40°C ~ +125°C) で仕様が規定されています。

### 製品情報

型番	パッケージ <sup>(1)</sup> (1 ページ)	本体サイズ (公称)
OPA388	SOIC (8)	4.90mm×3.90mm
	SOT-23 (5)	2.90mm×1.60mm
	VSSOP (8)	3.00mm×3.00mm
OPA2388	SOIC (8)	4.90mm×3.90mm
	VSSOP (8)	3.00mm×3.00mm
OPA4388	SOIC (14)	8.65mm×3.90mm
	TSSOP (14)	5.00mm×4.40mm

- (1) 利用可能なすべてのパッケージについては、このデータシートの末尾にあるパッケージ・オプションについての付録を参照してください。

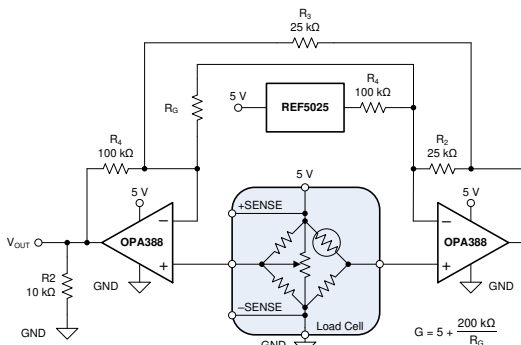

高 CMRR の計装アンプ用途に OPA388 を使用する例

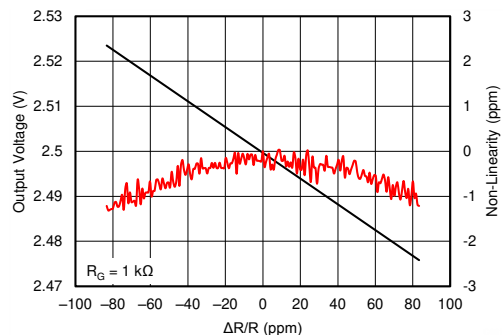

OPA388 により高精度、低誤差の測定が可能



## Table of Contents

<b>1 特長</b> .....	1	7.4 Device Functional Modes.....	20
<b>2 アプリケーション</b> .....	1	<b>8 Application and Implementation</b> .....	21
<b>3 概要</b> .....	1	8.1 Application Information.....	21
<b>4 Revision History</b> .....	2	8.2 Typical Applications.....	21
<b>5 Pin Configuration and Functions</b> .....	4	<b>9 Power Supply Recommendations</b> .....	25
<b>6 Specifications</b> .....	6	<b>10 Layout</b> .....	26
6.1 Absolute Maximum Ratings.....	6	10.1 Layout Guidelines.....	26
6.2 ESD Ratings.....	6	10.2 Layout Example.....	26
6.3 Recommended Operating Conditions.....	6	<b>11 Device and Documentation Support</b> .....	27
6.4 Thermal Information: OPA388.....	6	11.1 Device Support.....	27
6.5 Thermal Information: OPA2388.....	7	11.2 Documentation Support.....	27
6.6 Thermal Information: OPA4388.....	7	11.3 Related Links.....	27
6.7 Electrical Characteristics: $V_S = \pm 1.25\text{ V to } \pm 2.75\text{ V}$ ( $V_S = 2.5\text{ to } 5.5\text{ V}$ ).....	7	11.4 Receiving Notification of Documentation Updates..	28
6.8 Typical Characteristics.....	10	11.5 Support Resources.....	28
<b>7 Detailed Description</b> .....	18	11.6 Trademarks.....	28
7.1 Overview.....	18	11.7 Electrostatic Discharge Caution.....	28
7.2 Functional Block Diagram.....	18	11.8 Glossary.....	28
7.3 Feature Description.....	19	<b>12 Mechanical, Packaging, and Orderable Information</b> .....	28

## 4 Revision History

資料番号末尾の英字は改訂を表しています。その改訂履歴は英語版に準じています。

Changes from Revision C (May 2019) to Revision D (July 2020)	Page
• OPA2388 SOIC-8 (D) パッケージを事前情報 (プレビュー) から量産データ (アクティブ) に変更.....	1
• 参照識別子の表示位置が正しくなるように代表的な応用回路の回路図を変更.....	1
• Changed Figure 8-5 to show correct locations for reference designators .....	25
Changes from Revision B (January 2019) to Revision C (May 2019)	Page
• OPA4388 を事前情報 (プレビュー) から量産データ (アクティブ) に変更.....	1
• Added VOS specifications for OPA4388.....	7
• Added dVOS/dT specifications for OPA4388.....	7
• Added PSRR specifications for OPA4388.....	7
• Added IB specifications for OPA4388.....	7
• Added IOS specifications for OPA4388.....	7
• Added CMRR specifications for OPA4388.....	7
• Added AOL specifications for OPA4388.....	7
Changes from Revision A (July 2018) to Revision B (January 2019)	Page
• OPA388 の DBV (SOT-23) パッケージをプレビューから量産データに変更.....	1
• Deleted redundant temperature specification in EC table.....	7
• Added Figure 6, <i>Offset Voltage vs Supply Voltage: OPA4388</i> .....	10
• Added Figure 7, <i>Offset Voltage Long Term Drift</i> .....	10
• Changed Figure 50, <i>OPA388 Layout Example</i> ; updated for accuracy.....	26

**Changes from Revision \* (December 2016) to Revision A (July 2018)**

**Page**

• デバイスのステータスを量産データから量産データ / 混在ステータスに変更.....	1
• 上端に TI リファレンス・ デザインへのナビゲーション・ リンクを追加.....	1
• 製品情報の表に 5 ピン SOT-23 (OPA388)、8 ピン SOIC (OPA2388)、14 ピン SOIC、14 ピン TSSOP (OPA4388) のパッケージのプレビュー注記を追加.....	1
• Added package preview notes to <i>Pin Configuration and Functions</i> section.....	4
• AOL test condition changed to 0.15 V from 0.1 V.....	7
• AOL test condition changed to 0.15 V from 0.1 V.....	7
• AOL test condition changed to 0.25 V from 0.2 V.....	7
• AOL test condition changed to 0.3 V from 0.25 V.....	7

## 5 Pin Configuration and Functions

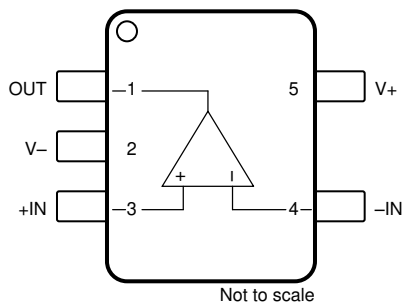

✎ 5-1. OPA388 DBV Package, 5-Pin SOT-23, Top View

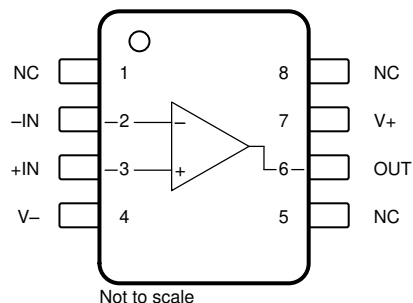

✎ 5-2. OPA388 D and DGK Packages, 8-Pin SOIC and VSSOP, Top View

### Pin Functions: OPA388

NAME	PIN		I/O	DESCRIPTION
	OPA388			
	D (SOIC), DGK (VSSOP)	DBV (SOT-23)		
-IN	2	4	I	Inverting input
+IN	3	3	I	Noninverting input
NC	1, 5, 8	—	—	No internal connection (can be left floating)
OUT	6	1	O	Output
V-	4	2	—	Negative (lowest) power supply
V+	7	5	—	Positive (highest) power supply



图 5-3. OPA2388 8-Pin SOIC (D) Package and 8-Pin VSSOP (DGK) Package, Top View



图 5-4. OPA4388 14-Pin SOIC (D) and TSSOP-14 (PW) Packages, Top View

**Pin Functions: OPA2388 and OPA4388**

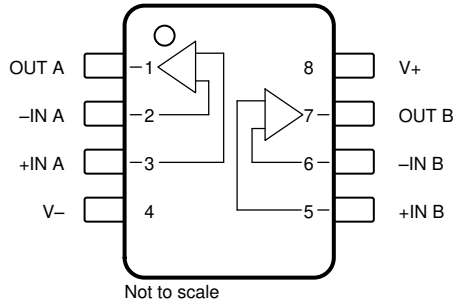
NAME	PIN		I/O	DESCRIPTION
	OPA2388 D (SOIC), DGK (VSSOP)	OPA4388 D (SOIC), PW (TSSOP)		
-IN A	2	2	I	Inverting input, channel A
-IN B	6	6	I	Inverting input, channel B
-IN C	—	9	I	Inverting input, channel C
-IN D	—	13	I	Inverting input, channel D
+IN A	3	3	I	Noninverting input, channel A
+IN B	5	5	I	Noninverting input, channel B
+IN C	—	10	I	Noninverting input, channel C
+IN D	—	12	I	Noninverting input, channel D
OUT A	1	1	O	Output, channel A
OUT B	7	7	O	Output, channel B
OUT C	—	8	O	Output, channel C
OUT D	—	14	O	Output, channel D
V-	4	11	—	Negative (lowest) power supply
V+	8	4	—	Positive (highest) power supply

## 6 Specifications

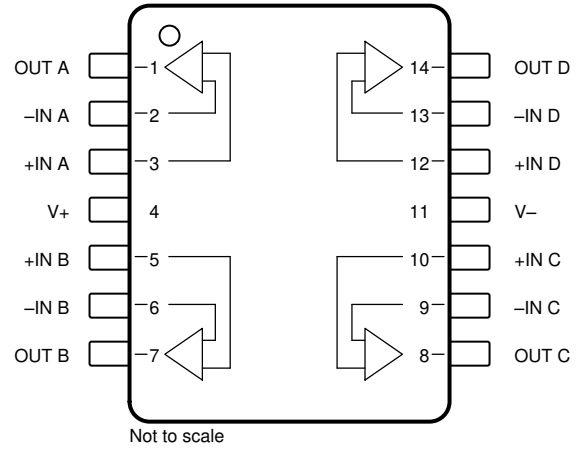
### 6.1 Absolute Maximum Ratings

over operating free-air temperature range (unless otherwise noted)<sup>(1)</sup>

			MIN	MAX	UNIT
Supply voltage	$V_S = (V+) - (V-)$	Single-supply		6	V
		Dual-supply		±3	
Signal input pins	Voltage	Common-mode	(V-) – 0.5	(V+) + 0.5	V
		Differential		(V+) – (V-) + 0.2	
	Current			±10	mA
Output short circuit <sup>(2)</sup>			Continuous	Continuous	
Temperature	Operating, $T_A$		–55	150	°C
	Junction, $T_J$			150	
	Storage, $T_{stg}$		–65	150	

(1) Stresses beyond those listed under *Absolute Maximum Ratings* may cause permanent damage to the device. These are stress ratings only, which do not imply functional operation of the device at these or any other conditions beyond those indicated under *Recommended Operating Conditions*. Exposure to absolute-maximum-rated conditions for extended periods may affect device reliability.

(2) Short-circuit to ground, one amplifier per package.

### 6.2 ESD Ratings

			VALUE	UNIT
$V_{(ESD)}$	Electrostatic discharge	Human-body model (HBM), per ANSI/ESDA/JEDEC JS-001 <sup>(1)</sup>	±4000	V
		Charged-device model (CDM), per JEDEC specification JESD22-C101 <sup>(2)</sup>	±1000	

(1) JEDEC document JEP155 states that 500-V HBM allows safe manufacturing with a standard ESD control process.

(2) JEDEC document JEP157 states that 250-V CDM allows safe manufacturing with a standard ESD control process.

### 6.3 Recommended Operating Conditions

over operating free-air temperature range (unless otherwise noted)

		MIN	NOM	MAX	UNIT
Supply voltage, $V_S = (V+) - (V-)$	Single-supply	2.5		5.5	V
	Dual-supply	±1.25		±2.75	
Specified temperature		–40		125	°C

### 6.4 Thermal Information: OPA388

THERMAL METRIC <sup>(1)</sup>		OPA388			UNIT
		D (SOIC)	DBV (SOT-23)	DGK (VSSOP)	
		8 PINS	5 PINS	5 PINS	
$R_{\theta JA}$	Junction-to-ambient thermal resistance	116	145.7	177	°C/W
$R_{\theta JC(top)}$	Junction-to-case (top) thermal resistance	60	94.8	69	°C/W
$R_{\theta JB}$	Junction-to-board thermal resistance	56	43.4	100	°C/W
$\Psi_{JT}$	Junction-to-top characterization parameter	12.8	24.7	9.9	°C/W
$\Psi_{JB}$	Junction-to-board characterization parameter	55.9	43.1	98.3	°C/W
$R_{\theta JC(bot)}$	Junction-to-case (bottom) thermal resistance	N/A	N/A	n/a	°C/W

(1) For more information about traditional and new thermal metrics, see the *Semiconductor and IC Package Thermal Metrics* application report.

## 6.5 Thermal Information: OPA2388

THERMAL METRIC <sup>(1)</sup>		OPA2388		UNIT
		D (SOIC)	DGK (VSSOP)	
		8 PINS	8 PINS	
R <sub>θJA</sub>	Junction-to-ambient thermal resistance	120.0	165	°C/W
R <sub>θJC(top)</sub>	Junction-to-case (top) thermal resistance	52.3	53	°C/W
R <sub>θJB</sub>	Junction-to-board thermal resistance	65.6	87	°C/W
Ψ <sub>JT</sub>	Junction-to-top characterization parameter	9.6	4.9	°C/W
Ψ <sub>JB</sub>	Junction-to-board characterization parameter	64.4	85	°C/W
R <sub>θJC(bot)</sub>	Junction-to-case (bottom) thermal resistance	N/A	N/A	°C/W

(1) For more information about traditional and new thermal metrics, see the *Semiconductor and IC Package Thermal Metrics* application report.

## 6.6 Thermal Information: OPA4388

THERMAL METRIC <sup>(1)</sup>		OPA4388		UNIT
		D (SOIC)	PW (TSSOP)	
		14 PINS	14 PINS	
R <sub>θJA</sub>	Junction-to-ambient thermal resistance	86.4	109.6	°C/W
R <sub>θJC(top)</sub>	Junction-to-case (top) thermal resistance	46.3	27.4	°C/W
R <sub>θJB</sub>	Junction-to-board thermal resistance	41.0	56.1	°C/W
Ψ <sub>JT</sub>	Junction-to-top characterization parameter	11.3	1.5	°C/W
Ψ <sub>JB</sub>	Junction-to-board characterization parameter	40.7	54.9	°C/W
R <sub>θJC(bot)</sub>	Junction-to-case (bottom) thermal resistance	N/A	N/A	°C/W

(1) For more information about traditional and new thermal metrics, see the *Semiconductor and IC Package Thermal Metrics* application report.

## 6.7 Electrical Characteristics: VS = ±1.25 V to ±2.75 V (VS = 2.5 to 5.5 V)

at T<sub>A</sub> = 25°C, V<sub>CM</sub> = V<sub>OUT</sub> = V<sub>S</sub> / 2, and R<sub>LOAD</sub> = 10 kΩ connected to V<sub>S</sub> / 2 (unless otherwise noted)

PARAMETER		TEST CONDITIONS		MIN	TYP	MAX	UNIT
<b>OFFSET VOLTAGE</b>							
V <sub>OS</sub>	Input offset voltage		OPA388, OPA2388	±0.25		±5	μV
		V <sub>S</sub> = 5.5 V	OPA4388	±2.25		±8	
		T <sub>A</sub> = -40°C to +125°C	OPA388, OPA2388			±7.5	
		T <sub>A</sub> = -40°C to +125°C, V <sub>S</sub> = 5.5 V	OPA4388			±10.5	
dV <sub>OS</sub> /dT	Input offset voltage drift	T <sub>A</sub> = -40°C to +125°C	OPA388, OPA2388	±0.005		±0.05	μV/°C
		T <sub>A</sub> = -40°C to +125°C, V <sub>S</sub> = 5.5 V	OPA4388	±0.005		±0.05	
PSRR	Power-supply rejection ratio	T <sub>A</sub> = -40°C to +125°C	OPA388, OPA2388	±0.1		±1	μV/V
			OPA4388	±1.25		±3.5	

**OPA388, OPA2388, OPA4388**

JAJSCU7D – DECEMBER 2016 – REVISED JULY 2020

 at  $T_A = 25^\circ\text{C}$ ,  $V_{CM} = V_{OUT} = V_S / 2$ , and  $R_{LOAD} = 10\text{ k}\Omega$  connected to  $V_S / 2$  (unless otherwise noted)

PARAMETER		TEST CONDITIONS		MIN	TYP	MAX	UNIT
<b>INPUT BIAS CURRENT</b>							
$I_B$	Input bias current	$R_{IN} = 100\text{ k}\Omega$ , OPA388, OPA2388	$T_A = 0^\circ\text{C to } +85^\circ\text{C}$		$\pm 30$	$\pm 350$	pA
			$T_A = -40^\circ\text{C to } +125^\circ\text{C}$			$\pm 400$	
						$\pm 700$	
		$R_{IN} = 100\text{ k}\Omega$ , OPA4388	$T_A = 0^\circ\text{C to } +85^\circ\text{C}$		$\pm 30$	$\pm 500$	
			$T_A = -40^\circ\text{C to } +125^\circ\text{C}$			$\pm 600$	
						$\pm 800$	
$I_{OS}$	Input offset current	$R_{IN} = 100\text{ k}\Omega$ , OPA388, OPA2388	$T_A = 0^\circ\text{C to } +85^\circ\text{C}$			$\pm 700$	
			$T_A = -40^\circ\text{C to } +125^\circ\text{C}$			$\pm 800$	
						$\pm 1000$	
		$R_{IN} = 100\text{ k}\Omega$ , OPA4388	$T_A = 0^\circ\text{C to } +85^\circ\text{C}$			$\pm 1100$	
			$T_A = -40^\circ\text{C to } +125^\circ\text{C}$			$\pm 1100$	
						$\pm 1100$	
<b>NOISE</b>							
$E_N$	Input voltage noise	$f = 0.1\text{ Hz to } 10\text{ Hz}$			0.14		$\mu\text{V}_{PP}$
$e_N$	Input voltage noise density	$f = 10\text{ Hz}$			7		nV/ $\sqrt{\text{Hz}}$
		$f = 100\text{ Hz}$			7		
		$f = 1\text{ kHz}$			7		
		$f = 10\text{ kHz}$			7		
$I_N$	Input current noise density	$f = 1\text{ kHz}$			100		fA/ $\sqrt{\text{Hz}}$
<b>INPUT VOLTAGE</b>							
$V_{CM}$	Common-mode voltage range			$(V-) - 0.1$		$(V+) + 0.1$	V
CMRR	Common-mode rejection ratio	$(V-) - 0.1\text{ V} < V_{CM} < (V+) + 0.1\text{ V}$	$V_S = \pm 1.25\text{ V}$ OPA388, OPA2388	124	138		dB
			$V_S = \pm 1.25\text{ V}$ OPA4388	102	110		
			$V_S = \pm 2.75\text{ V}$	124	140		
		$(V-) < V_{CM} < (V+) + 0.1\text{ V}$ , $T_A = -40^\circ\text{C to } +125^\circ\text{C}$	$V_S = \pm 1.25\text{ V}$ OPA388, OPA2388	114	134		
			$V_S = \pm 1.25\text{ V}$ OPA4388	102	107		
			$V_S = \pm 2.75\text{ V}$	124	140		
<b>INPUT IMPEDANCE</b>							
$Z_{id}$	Differential input impedance				$100 \parallel 2$		$\text{M}\Omega \parallel \text{pF}$
$Z_{ic}$	Common-mode input impedance				$60 \parallel 4.5$		$\text{T}\Omega \parallel \text{pF}$

at  $T_A = 25^\circ\text{C}$ ,  $V_{CM} = V_{OUT} = V_S / 2$ , and  $R_{LOAD} = 10\text{ k}\Omega$  connected to  $V_S / 2$  (unless otherwise noted)

PARAMETER		TEST CONDITIONS		MIN	TYP	MAX	UNIT
<b>OPEN-LOOP GAIN</b>							
$A_{OL}$	Open-loop voltage gain	$(V-) + 0.15\text{ V} < V_O < (V+) - 0.15\text{ V}$ , $R_{LOAD} = 10\text{ k}\Omega$		126	148		dB
		$(V-) + 0.15\text{ V} < V_O < (V+) - 0.15\text{ V}$ , $R_{LOAD} = 10\text{ k}\Omega$ , $T_A = -40^\circ\text{C}$ to $+125^\circ\text{C}$		120	126	OPA388, OPA2388	
		$(V-) + 0.15\text{ V} < V_O < (V+) - 0.15\text{ V}$ , $R_{LOAD} = 10\text{ k}\Omega$ , $V_S = 5.5\text{ V}$ , $T_A = -40^\circ\text{C}$ to $+125^\circ\text{C}$		120	126	OPA4388	
		$(V-) + 0.25\text{ V} < V_O < (V+) - 0.25\text{ V}$ , $R_{LOAD} = 2\text{ k}\Omega$		126	148		
		$(V-) + 0.30\text{ V} < V_O < (V+) - 0.30\text{ V}$ , $R_{LOAD} = 2\text{ k}\Omega$		120	148	OPA388, OPA2388	
		$(V-) + 0.30\text{ V} < V_O < (V+) - 0.30\text{ V}$ , $R_{LOAD} = 2\text{ k}\Omega$ , $V_S = 5.5\text{ V}$ , $T_A = -40^\circ\text{C}$ to $+125^\circ\text{C}$		120	126	OPA4388	
<b>FREQUENCY RESPONSE</b>							
GBW	Unity-gain bandwidth				10		MHz
SR	Slew rate	$G = 1$ , 4-V step			5		V/ $\mu\text{s}$
THD+N	Total harmonic distortion + noise	$G = 1$ , $f = 1\text{ kHz}$ , $V_O = 1\text{ V}_{RMS}$			0.0005%		
$t_S$	Settling time	To 0.1%	$V_S = \pm 2.5\text{ V}$ , $G = 1$ , 1-V step		0.75		$\mu\text{s}$
		To 0.01%	$V_S = \pm 2.5\text{ V}$ , $G = 1$ , 1-V step		2		$\mu\text{s}$
$t_{OR}$	Overload recovery time	$V_{IN} \times G = V_S$			10		$\mu\text{s}$
<b>OUTPUT</b>							
$V_O$	Voltage output swing from rail	Positive rail	No load		1	15	mV
			$R_{LOAD} = 10\text{ k}\Omega$		5	20	
			$R_{LOAD} = 2\text{ k}\Omega$		20	50	
		Negative rail	No load		5	15	
			$R_{LOAD} = 10\text{ k}\Omega$		10	20	
			$R_{LOAD} = 2\text{ k}\Omega$		40	60	
		$T_A = -40^\circ\text{C}$ to $+125^\circ\text{C}$ , both rails, $R_{LOAD} = 10\text{ k}\Omega$			10	25	
$I_{SC}$	Short-circuit current	$V_S = 5.5\text{ V}$			$\pm 60$		mA
		$V_S = 2.5\text{ V}$			$\pm 30$		mA
$C_{LOAD}$	Capacitive load drive	See <a href="#">6-26</a>					
$Z_O$	Open-loop output impedance	$f = 1\text{ MHz}$ , $I_O = 0\text{ A}$ , see <a href="#">6-25</a>			100		$\Omega$
<b>POWER SUPPLY</b>							
$I_Q$	Quiescent current per amplifier	$V_S = \pm 1.25\text{ V}$ ( $V_S = 2.5\text{ V}$ )	$I_O = 0\text{ A}$		1.7	2.4	mA
			$T_A = -40^\circ\text{C}$ to $+125^\circ\text{C}$ , $I_O = 0\text{ A}$		1.7	2.4	
		$V_S = \pm 2.75\text{ V}$ ( $V_S = 5.5\text{ V}$ )	$I_O = 0\text{ A}$		1.9	2.6	
			$T_A = -40^\circ\text{C}$ to $+125^\circ\text{C}$ , $I_O = 0\text{ A}$		1.9	2.6	

## 6.8 Typical Characteristics

**Table 6-1. Table of Graphs**

DESCRIPTION	FIGURE
Offset Voltage Production Distribution	<a href="#">6-1</a>
Offset Voltage Drift Distribution From –40°C to +125°C	<a href="#">6-2</a>
Offset Voltage vs Temperature	<a href="#">6-3</a>
Offset Voltage vs Common-Mode Voltage	<a href="#">6-4</a>
Offset Voltage vs Power Supply: OPA388 and OPA2388	<a href="#">6-5</a>
Offset Voltage vs Power Supply: OPA4388	<a href="#">6-6</a>
Offset Voltage Long Term Drift	<a href="#">6-7</a>
Open-Loop Gain and Phase vs Frequency	<a href="#">6-8</a>
Closed-Loop Gain and Phase vs Frequency	<a href="#">6-9</a>
Input Bias Current vs Common-Mode Voltage	<a href="#">6-10</a>
Input Bias Current vs Temperature	<a href="#">6-11</a>
Output Voltage Swing vs Output Current (Maximum Supply)	<a href="#">6-12</a>
CMRR and PSRR vs Frequency	<a href="#">6-13</a>
CMRR vs Temperature	<a href="#">6-14</a>
PSRR vs Temperature	<a href="#">6-15</a>
0.1-Hz to 10-Hz Noise	<a href="#">6-16</a>
Input Voltage Noise Spectral Density vs Frequency	<a href="#">6-17</a>
THD+N Ratio vs Frequency	<a href="#">6-18</a>
THD+N vs Output Amplitude	<a href="#">6-19</a>
Spectral Content	<a href="#">6-20</a> , <a href="#">6-21</a>
Quiescent Current vs Supply Voltage	<a href="#">6-22</a>
Quiescent Current vs Temperature	<a href="#">6-23</a>
Open-Loop Gain vs Temperature	<a href="#">6-24</a>
Open-Loop Output Impedance vs Frequency	<a href="#">6-25</a>
Small-Signal Overshoot vs Capacitive Load (10-mV Step)	<a href="#">6-26</a>
No Phase Reversal	<a href="#">6-27</a>
Positive Overload Recovery	<a href="#">6-28</a>
Negative Overload Recovery	<a href="#">6-29</a>
Small-Signal Step Response (10-mV Step)	<a href="#">6-30</a> , <a href="#">6-31</a>
Large-Signal Step Response (4-V Step)	<a href="#">6-32</a> , <a href="#">6-33</a>
Settling Time	<a href="#">6-34</a> , <a href="#">6-35</a>
Short-Circuit Current vs Temperature	<a href="#">6-36</a>
Maximum Output Voltage vs Frequency	<a href="#">6-37</a>
EMIRR vs Frequency	<a href="#">6-38</a>

at  $T_A = 25^\circ\text{C}$ ,  $V_S = \pm 2.5\text{ V}$ ,  $V_{CM} = V_S / 2$ ,  $R_{LOAD} = 10\text{ k}\Omega$  connected to  $V_S / 2$ , and  $C_L = 100\text{ pF}$  (unless otherwise noted)

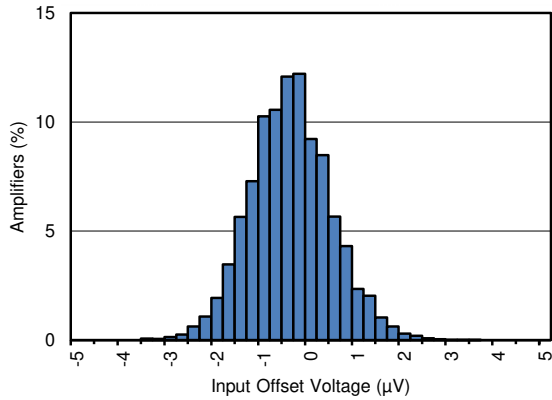

**6-1. Offset Voltage Production Distribution**

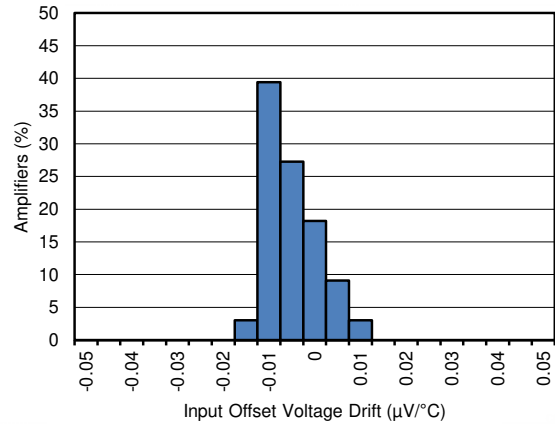

**6-2. Offset Voltage Drift Distribution From  $-40^\circ\text{C}$  to  $+125^\circ\text{C}$**

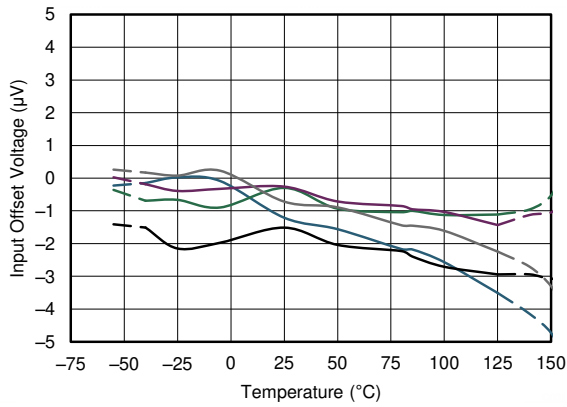

**6-3. Offset Voltage vs Temperature**

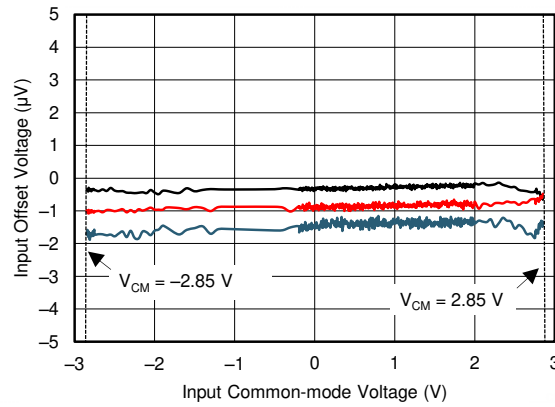

**6-4. Offset Voltage vs Common-Mode Voltage**

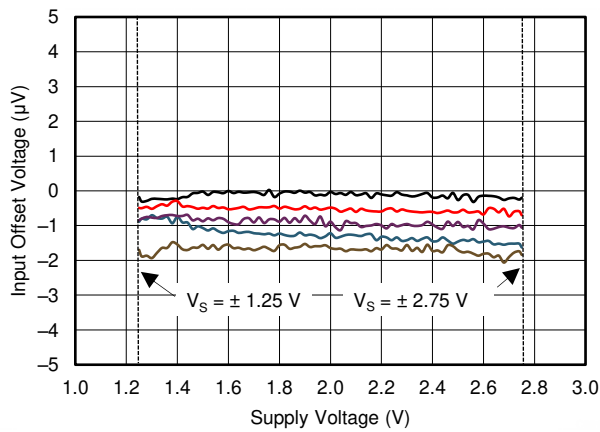

**6-5. Offset Voltage vs Supply Voltage: OPA388 and OPA2388**

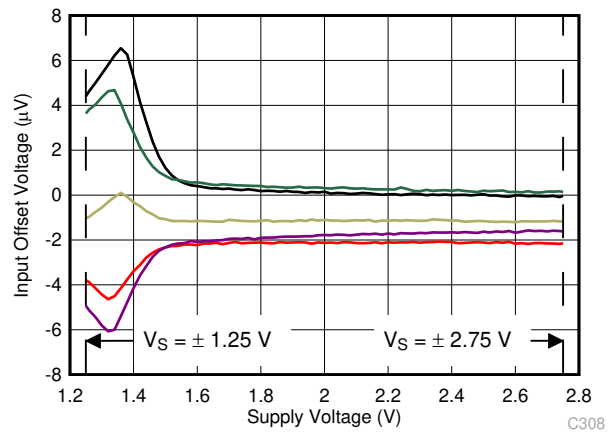

**6-6. Offset Voltage vs Supply Voltage: OPA4388**

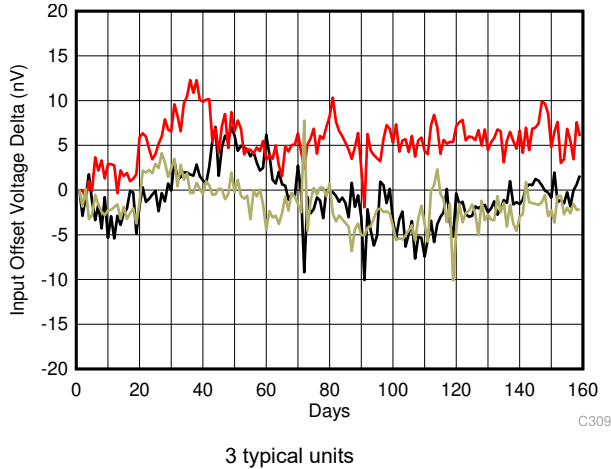

6-7. Offset Voltage Long Term Drift

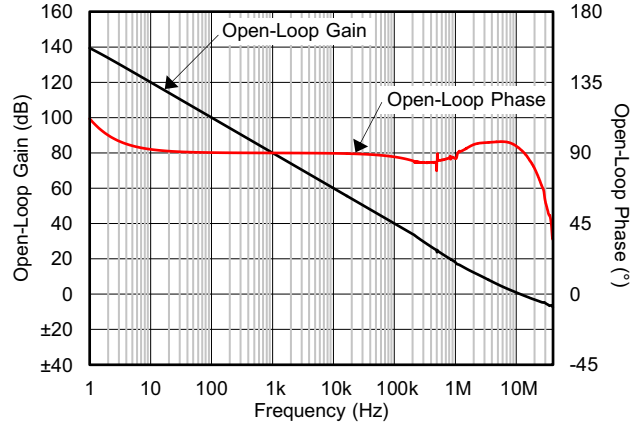

6-8. Open-Loop Gain and Phase vs Frequency

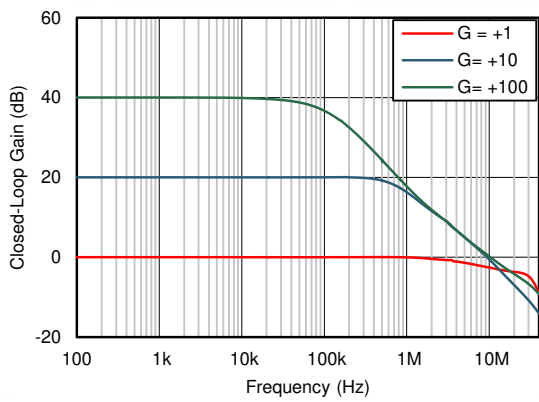

6-9. Closed-Loop Gain and Phase vs Frequency

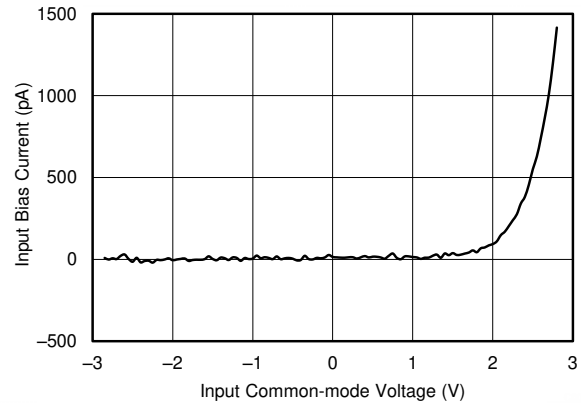

6-10. Input Bias Current vs Common-Mode Voltage

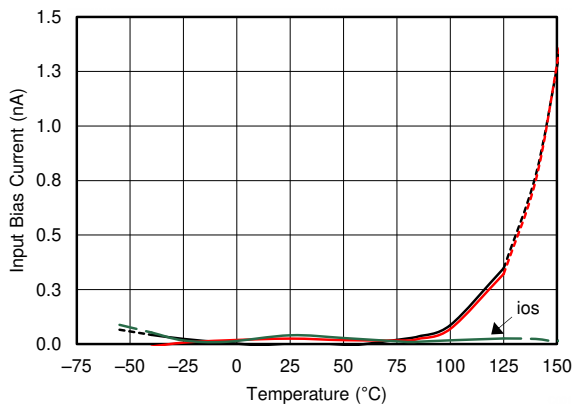

6-11. Input Bias Current vs Temperature

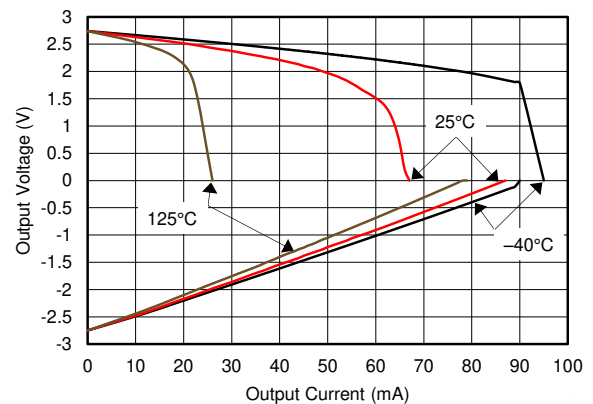

6-12. Output Voltage Swing vs Output Current (Maximum Supply)

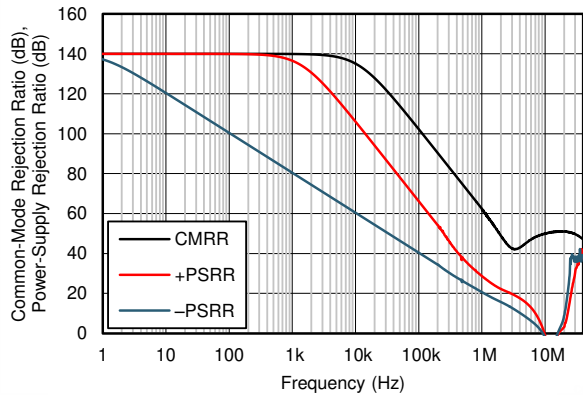

**6-13. CMRR and PSRR vs Frequency**

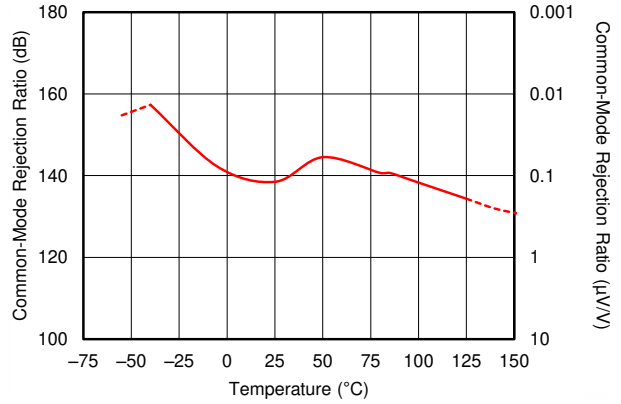

**6-14. CMRR vs Temperature**

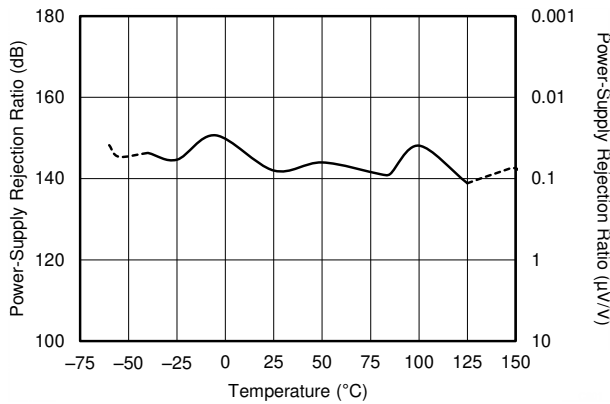

**6-15. PSRR vs Temperature**

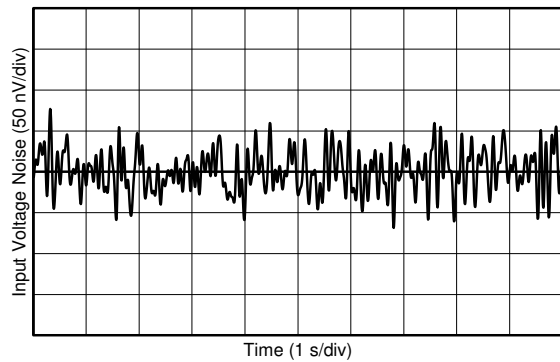

**6-16. 0.1-Hz to 10-Hz Noise**

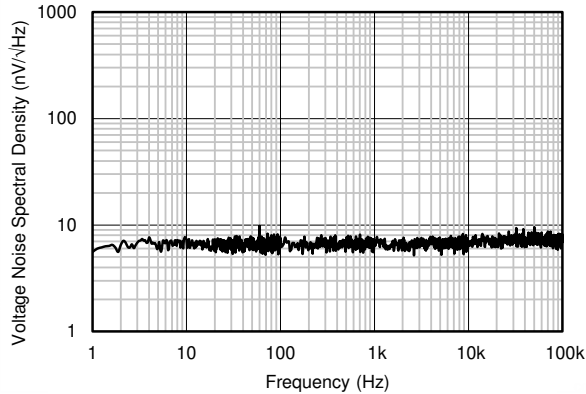

**6-17. Input Voltage Noise Spectral Density vs Frequency**

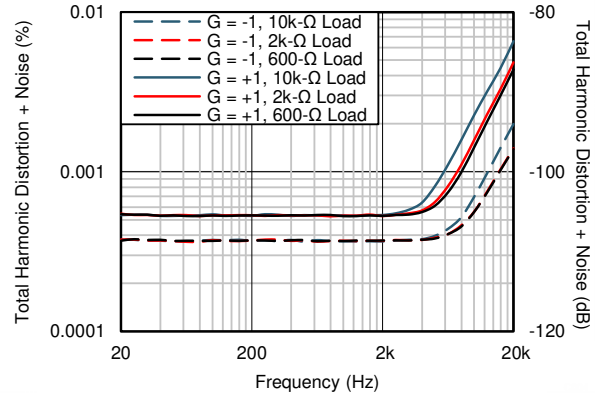

**6-18. THD+N Ratio vs Frequency**

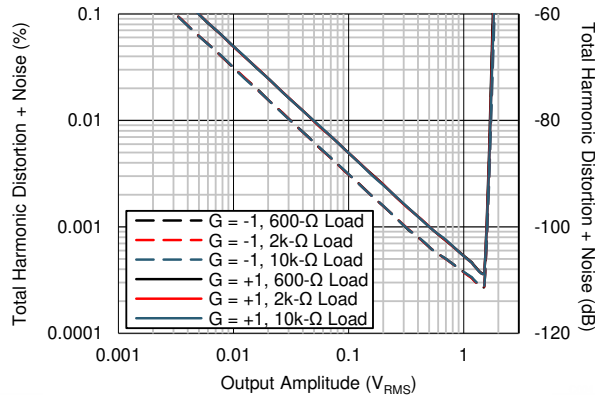

**6-19. THD+N vs Output Amplitude**

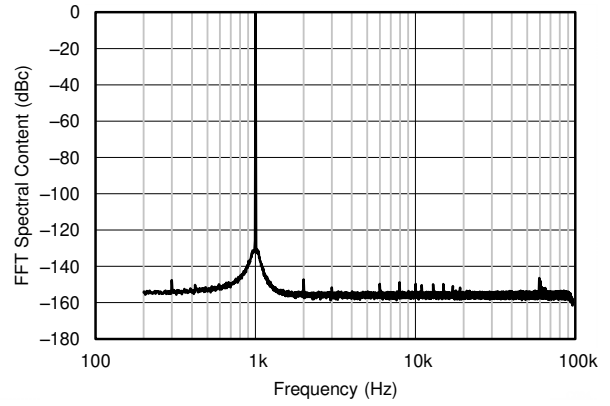

G = +1, f = 1 kHz, V<sub>O</sub> = 4.5 V<sub>PP</sub>, R<sub>L</sub> = 10 kΩ, BW = 90 kHz

**6-20. Spectral Content (With 10-kΩ Load)**

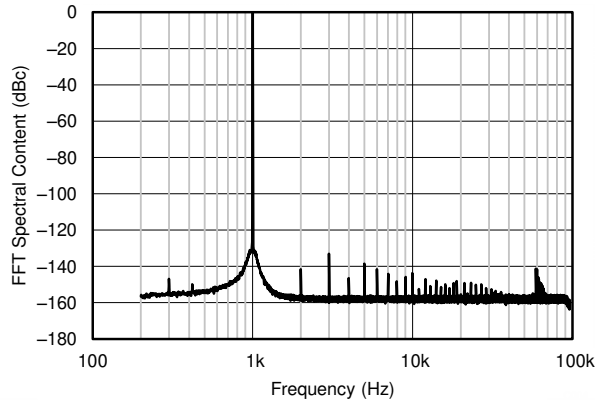

G = +1, f = 1 kHz, V<sub>O</sub> = 4.5 V<sub>PP</sub>, R<sub>L</sub> = 2 kΩ, BW = 90 kHz

**6-21. Spectral Content (With 2-kΩ Load)**

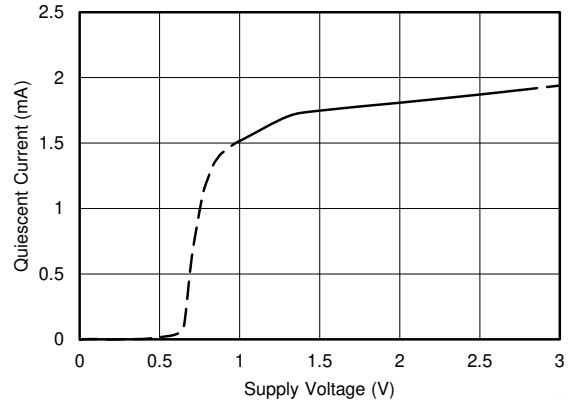

**6-22. Quiescent Current vs Supply Voltage**

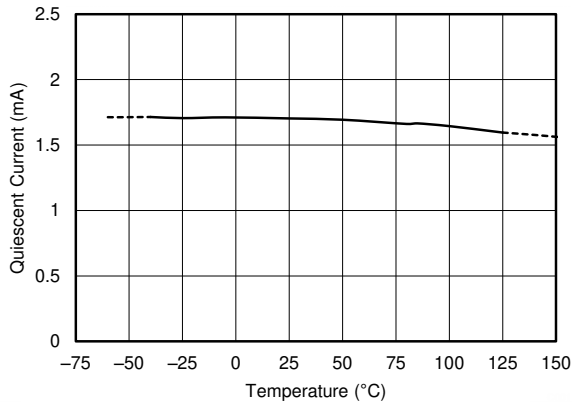

**6-23. Quiescent Current vs Temperature**

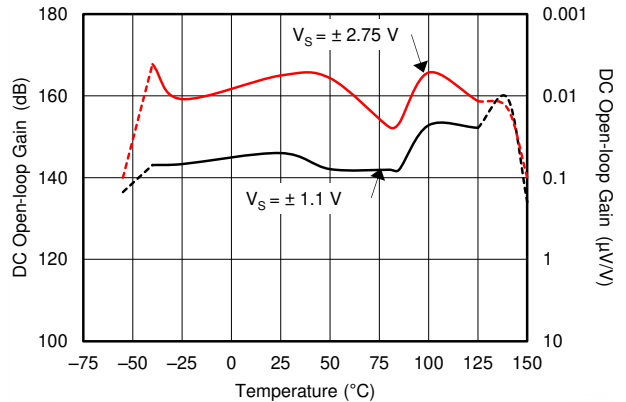

**6-24. Open-Loop Gain vs Temperature**

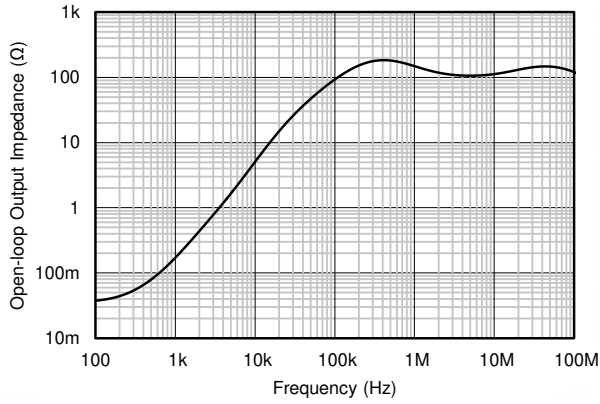

**6-25. Open-Loop Output Impedance vs Frequency**

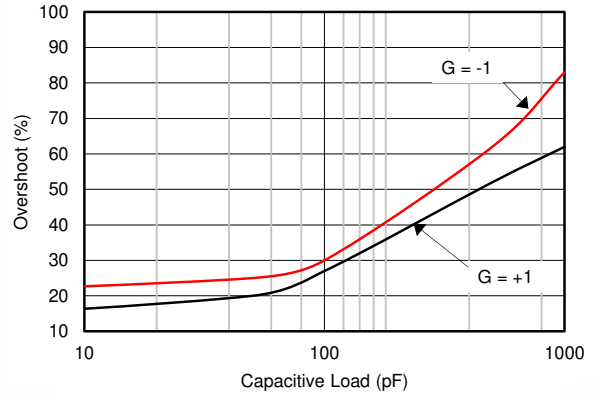

**6-26. Small-Signal Overshoot vs Capacitive Load (10-mV Step)**

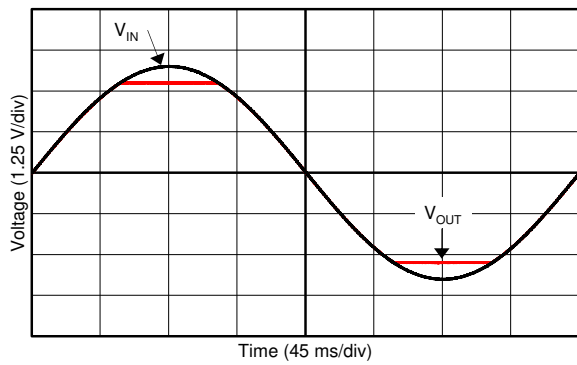

**6-27. No Phase Reversal**

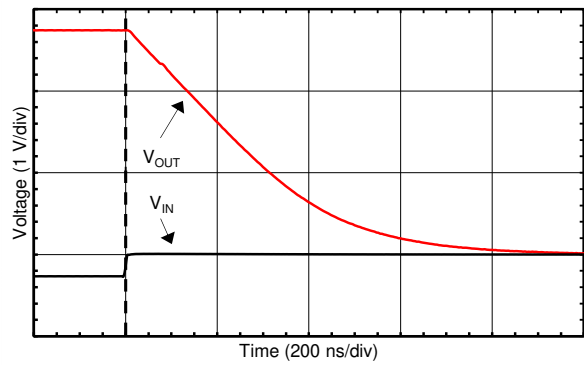

**6-28. Positive Overload Recovery**

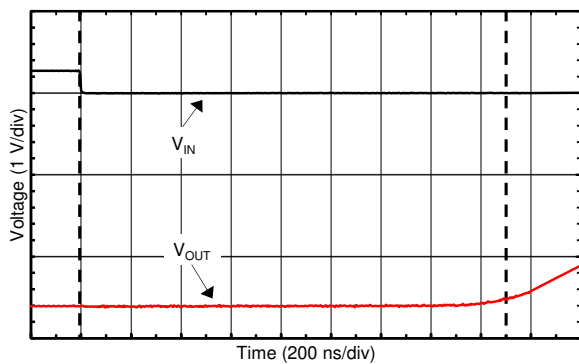

**6-29. Negative Overload Recovery**

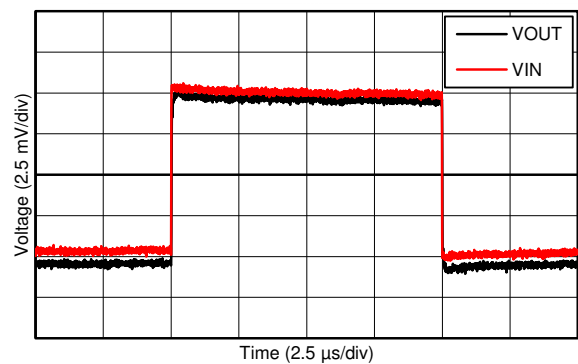

G = +1

**6-30. Small-Signal Step Response (10-mV Step)**

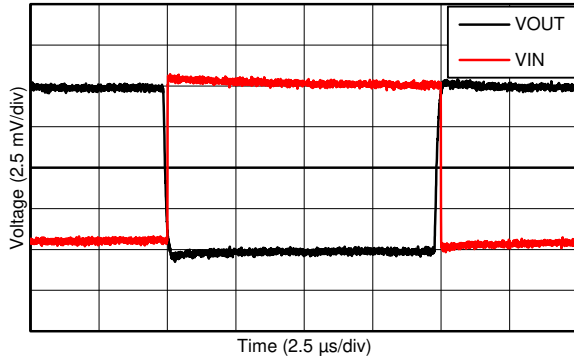

Time (2.5  $\mu$ s/div)

$G = -1$

**6-31. Small-Signal Step Response (10-mV Step)**

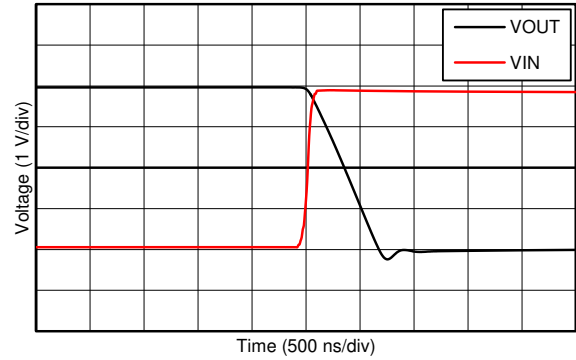

Time (500 ns/div)

Falling output

**6-32. Large-Signal Step Response (4-V Step)**

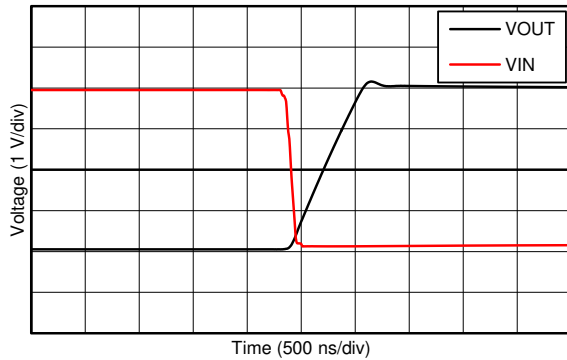

Time (500 ns/div)

Rising output

**6-33. Large-Signal Step Response (4-V Step)**

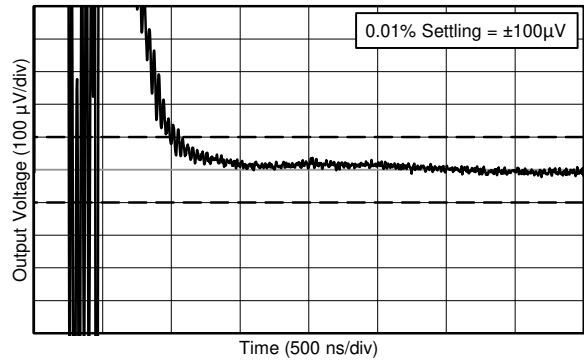

Time (500 ns/div)

0.01% settling =  $\pm 100 \mu$ V

**6-34. Settling Time (1-V Positive Step)**

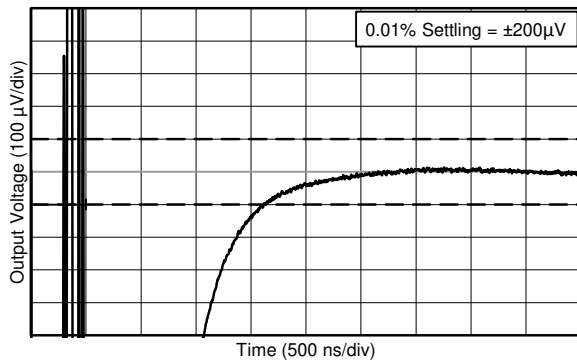

Time (500 ns/div)

0.01% settling =  $\pm 200 \mu$ V

**6-35. Settling Time (1-V Negative Step)**

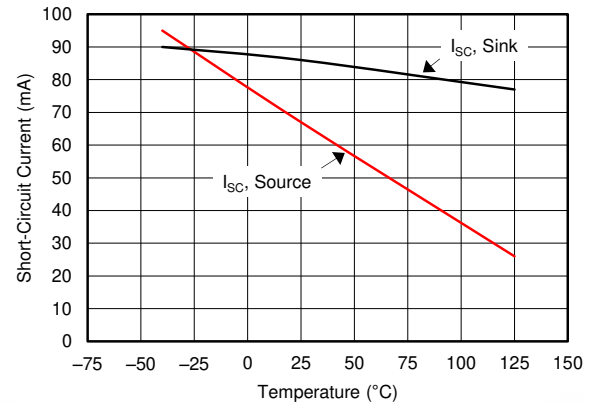

**6-36. Short-Circuit Current vs Temperature**

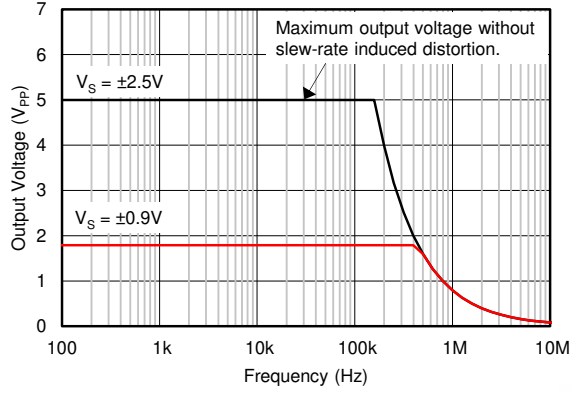

**6-37. Maximum Output Voltage vs Frequency**

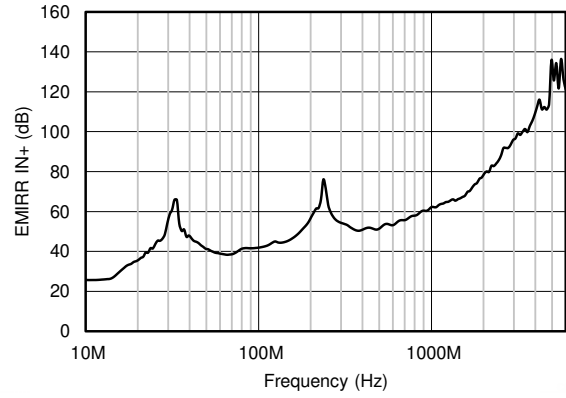

$P_{RF} = -10 \text{ dBm}$

**6-38. EMIRR vs Frequency**

## 7 Detailed Description

### 7.1 Overview

The OPAx388 family of zero-drift amplifiers is engineered with the unique combination of a proprietary precision auto-calibration technique paired with a low-noise, low-ripple, input charge pump. These amplifiers offer ultra-low input offset voltage and drift and achieve excellent input and output dynamic linearity. The OPAx388 operate from 2.5 V to 5.5 V, is unity-gain stable, and are designed for a wide range of general-purpose and precision applications. The integrated, low-noise charge pump allows true rail-to-rail input common-mode operation without distortion associated with complementary rail-to-rail input topologies (input crossover distortion). The OPAx388 strengths also include 10-MHz bandwidth,  $7\text{-nV}/\sqrt{\text{Hz}}$  noise spectral density, and no  $1/f$  noise, making the OPAx388 optimal for interfacing with sensor modules and buffering high-fidelity, digital-to-analog converters (DACs).

### 7.2 Functional Block Diagram

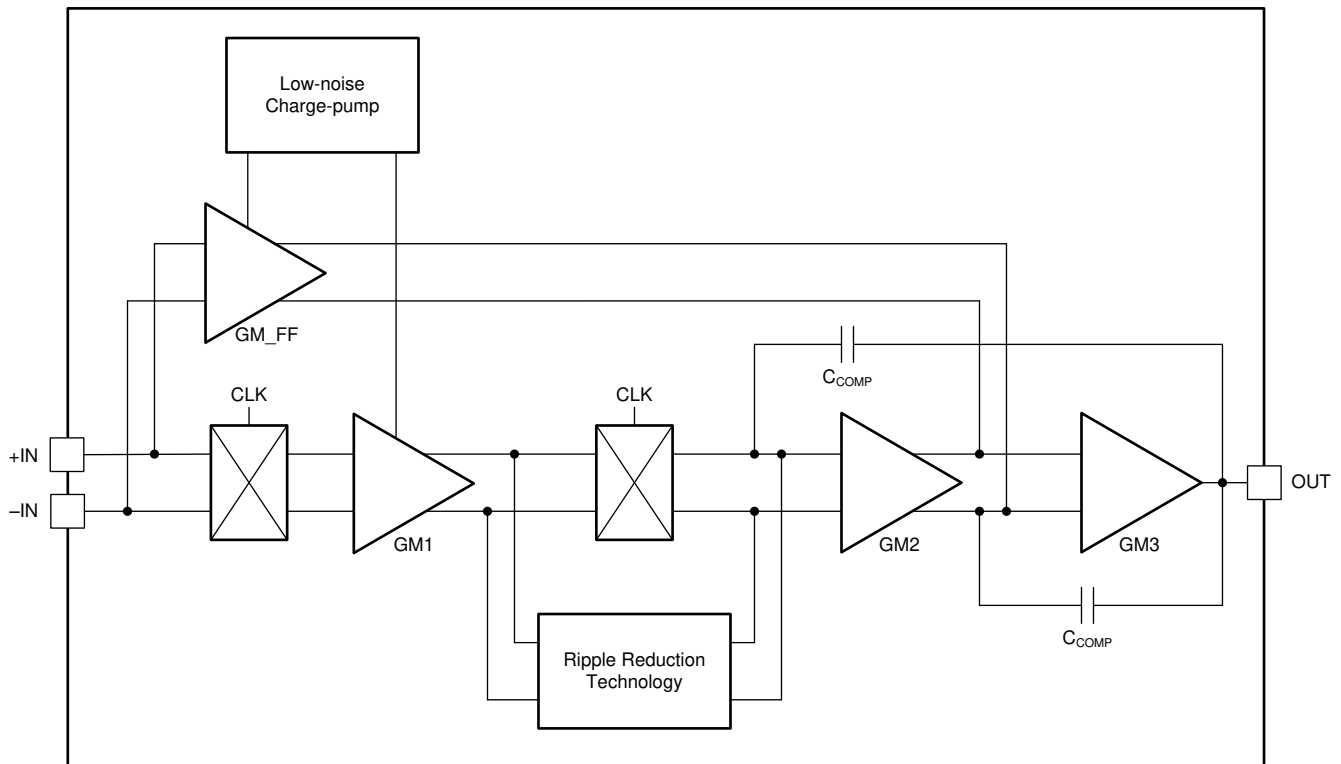

Copyright © 2016, Texas Instruments Incorporated

## 7.3 Feature Description

### 7.3.1 Operating Voltage

The OPAx388 family of operational amplifiers can be used with single or dual supplies from an operating range of  $V_S = 2.5\text{ V} (\pm 1.25\text{ V})$  up to  $5.5\text{ V} (\pm 2.75\text{ V})$ . Supply voltages greater than  $7\text{ V}$  can permanently damage the device (see the *Absolute Maximum Ratings* table). Key parameters that vary over the supply voltage or temperature range are shown in the *Typical Characteristics* section.

### 7.3.2 Input Voltage and Zero-Crossover Functionality

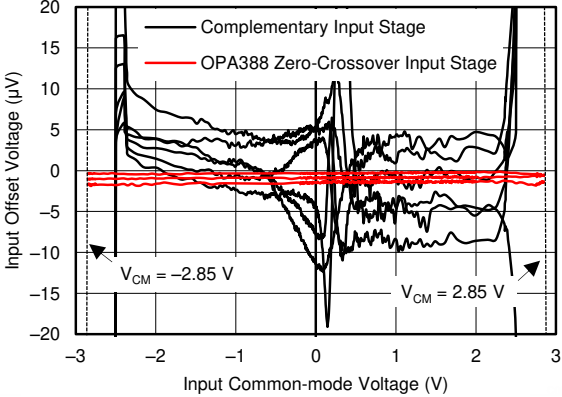
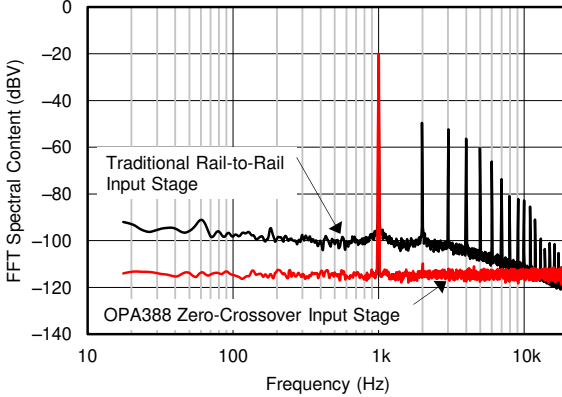
The OPAx388 input common-mode voltage range extends  $0.1\text{ V}$  beyond the supply rails. This amplifier family is designed to cover the full range without the troublesome transition region found in some other rail-to-rail amplifiers. Operating a complementary rail-to-rail input amplifier with signals traversing the transition region results in unwanted non-linear behavior and polluted spectral content.  and  contrast the performance of a traditional complementary rail-to-rail input stage amplifier with the performance of the zero-crossover OPA388. Significant harmonic content and distortion is generated during the differential pair transition (such a transition does not exist in the OPA388). Crossover distortion is eliminated through the use of a single differential pair coupled with an internal low-noise charge pump. The OPAx388 maintains noise, bandwidth, and offset performance throughout the input common-mode range, thus reducing printed circuit board (PCB) and bill of materials (BOM) complexity through the reduction of power-supply rails.

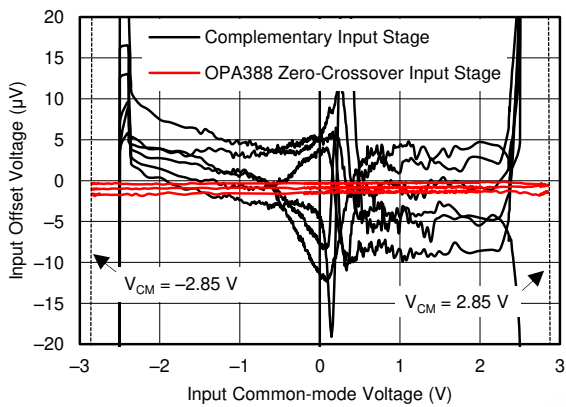

 **7-1. Input Crossover Distortion Nonlinearity**

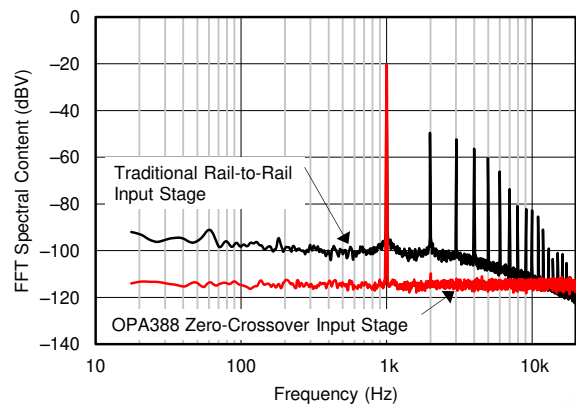

 **7-2. Input Crossover Distortion Spectral Content**

Typically, input bias current is approximately  $\pm 30$  pA. Input voltages exceeding the power supplies, however, can cause excessive current to flow into or out of the input pins. Momentary voltages greater than the power supply can be tolerated if the input current is limited to 10 mA. This limitation is easily accomplished with an input resistor, as shown in [Figure 7-3](#).

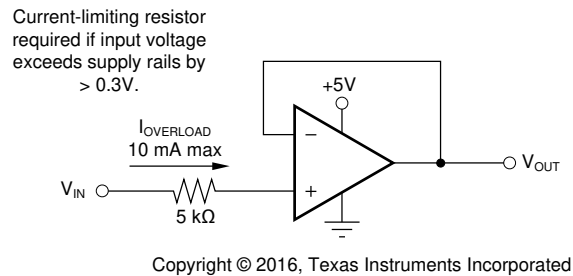

**Figure 7-3. Input Current Protection**

### 7.3.3 Input Differential Voltage

The typical input bias current of the OPAx388 during normal operation is approximately 30 pA. In overdriven conditions, the bias current can increase significantly. The most common cause of an overdriven condition occurs when the operational amplifier is outside of the linear range of operation. When the output of the operational amplifier is driven to one of the supply rails, the feedback loop requirements cannot be satisfied and a differential input voltage develops across the input pins. This differential input voltage results in activation of parasitic diodes inside the front-end input chopping switches that combine with 10-kΩ electromagnetic interference (EMI) filter resistors to create the equivalent circuit shown in [Figure 7-4](#). Notice that the input bias current remains within specification in the linear region.

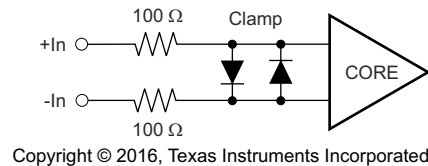

**Figure 7-4. Equivalent Input Circuit**

### 7.3.4 Internal Offset Correction

The OPA388 family of operational amplifiers uses an auto-calibration technique with a time-continuous, 200-kHz operational amplifier in the signal path. This amplifier is zero-corrected every 5  $\mu$ s using a proprietary technique. At power-up, the amplifier requires approximately 1 ms to achieve the specified  $V_{OS}$  accuracy. This design has no aliasing or flicker noise.

### 7.3.5 EMI Susceptibility and Input Filtering

Operational amplifiers vary in susceptibility to EMI. If conducted EMI enters the operational amplifier, the dc offset at the amplifier output can shift from its nominal value when EMI is present. This shift is a result of signal rectification associated with the internal semiconductor junctions. Although all operational amplifier pin functions can be affected by EMI, the input pins are likely to be the most susceptible. The OPAx388 operational amplifier family incorporates an internal input low-pass filter that reduces the amplifier response to EMI. Both common-mode and differential-mode filtering are provided by the input filter. The filter is designed for a cutoff frequency of approximately 20 MHz ( $-3$  dB), with a rolloff of 20 dB per decade.

## 7.4 Device Functional Modes

The OPA388 has a single functional mode and is operational when the power-supply voltage is greater than 2.5 V ( $\pm 1.25$  V). The maximum specified power-supply voltage for the OPAx388 is 5.5 V ( $\pm 2.75$  V).

## 8 Application and Implementation

### Note

Information in the following applications sections is not part of the TI component specification, and TI does not warrant its accuracy or completeness. TI's customers are responsible for determining suitability of components for their purposes. Customers should validate and test their design implementation to confirm system functionality.

### 8.1 Application Information

The OPAx388 is a unity-gain stable, precision operational amplifier family free from unexpected output and phase reversal. The use of proprietary zero-drift circuitry gives the benefit of low input offset voltage over time and temperature, as well as lowering the 1/f noise component. As a result of the high PSRR, these devices work well in applications that run directly from battery power without regulation. The OPAx388 family is optimized for full rail-to-rail input, allowing for low-voltage, single-supply operation or split-supply use. These miniature, high-precision, low-noise amplifiers offer high-impedance inputs that have a common-mode range 100 mV beyond the supplies without input crossover distortion and a rail-to-rail output that swings within 5 mV of the supplies under normal test conditions. The OPAx388 series of precision amplifiers is designed for upstream analog signal chain applications in low or high gains, as well as downstream signal chain functions such as DAC buffering.

### 8.2 Typical Applications

#### 8.2.1 Bidirectional Current-Sensing

This single-supply, low-side, bidirectional current-sensing solution detects load currents from  $-1\text{ A}$  to  $+1\text{ A}$ . The single-ended output spans from 110 mV to 3.19 V. This design uses the OPAx388 because of its low offset voltage and rail-to-rail input and output. One of the amplifiers is configured as a difference amplifier and the other amplifier provides the reference voltage.

Figure 8-1 shows the solution.

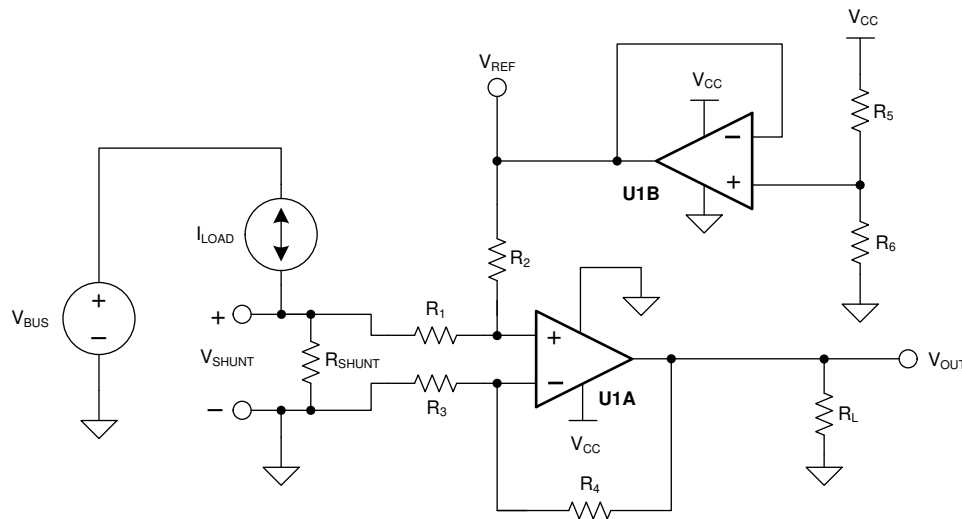

Figure 8-1. Bidirectional Current-Sensing Schematic

### 8.2.1.1 Design Requirements

This solution has the following requirements:

- Supply voltage: 3.3 V
- Input: –1 A to 1 A
- Output: 1.65 V ±1.54 V (110 mV to 3.19 V)

### 8.2.1.2 Detailed Design Procedure

The load current,  $I_{LOAD}$ , flows through the shunt resistor ( $R_{SHUNT}$ ) to develop the shunt voltage,  $V_{SHUNT}$ . The shunt voltage is then amplified by the difference amplifier consisting of U1A and  $R_1$  through  $R_4$ . The gain of the difference amplifier is set by the ratio of  $R_4$  to  $R_3$ . To minimize errors, set  $R_2 = R_4$  and  $R_1 = R_3$ . The reference voltage,  $V_{REF}$ , is supplied by buffering a resistor divider using U1B. The transfer function is given by [Equation 1](#).

$$V_{OUT} = V_{SHUNT} \times \text{Gain}_{\text{Diff\_Amp}} + V_{REF} \quad (1)$$

where

- $V_{SHUNT} = I_{LOAD} \times R_{SHUNT}$
- $\text{Gain}_{\text{Diff\_Amp}} = \frac{R_4}{R_3}$
- $V_{REF} = V_{CC} \times \left( \frac{R_6}{R_5 + R_6} \right)$

There are two types of errors in this design: offset and gain. Gain errors are introduced by the tolerance of the shunt resistor and the ratios of  $R_4$  to  $R_3$  and, similarly,  $R_2$  to  $R_1$ . Offset errors are introduced by the voltage divider ( $R_5$  and  $R_6$ ) and how closely the ratio of  $R_4 / R_3$  matches  $R_2 / R_1$ . The latter value affects the CMRR of the difference amplifier, ultimately translating to an offset error.

The value of  $V_{SHUNT}$  is the ground potential for the system load because  $V_{SHUNT}$  is a low-side measurement. Therefore, a maximum value must be placed on  $V_{SHUNT}$ . In this design, the maximum value for  $V_{SHUNT}$  is set to 100 mV. [Equation 2](#) calculates the maximum value of the shunt resistor given a maximum shunt voltage of 100 mV and maximum load current of 1 A.

$$R_{SHUNT(\text{Max})} = \frac{V_{SHUNT(\text{Max})}}{I_{LOAD(\text{Max})}} = \frac{100 \text{ mV}}{1 \text{ A}} = 100 \text{ m}\Omega \quad (2)$$

The tolerance of  $R_{SHUNT}$  is directly proportional to cost. For this design, a shunt resistor with a tolerance of 0.5% was selected. If greater accuracy is required, select a 0.1% resistor or better.

The load current is bidirectional; therefore, the shunt voltage range is –100 mV to 100 mV. This voltage is divided down by  $R_1$  and  $R_2$  before reaching the operational amplifier, U1A. Make sure that the voltage present at the noninverting node of U1A is within the common-mode range of the device. Therefore, use an operational amplifier, such as the OPA388, that has a common-mode range that extends below the negative supply voltage. Finally, to minimize offset error, note that the OPA388 has a typical offset voltage of merely ±0.25 μV (±5 μV maximum).

Given a symmetric load current of –1 A to 1 A, the voltage divider resistors ( $R_5$  and  $R_6$ ) must be equal. To be consistent with the shunt resistor, a tolerance of 0.5% was selected. To minimize power consumption, 10-kΩ resistors were used.

To set the gain of the difference amplifier, the common-mode range and output swing of the OPA388 must be considered. Equation 3 and Equation 4 depict the typical common-mode range and maximum output swing, respectively, of the OPA388 given a 3.3-V supply.

$$-100 \text{ mV} < V_{\text{CM}} < 3.4 \text{ V} \quad (3)$$

$$100 \text{ mV} < V_{\text{OUT}} < 3.2 \text{ V} \quad (4)$$

The gain of the difference amplifier can now be calculated as shown in Equation 5.

$$\text{Gain}_{\text{Diff\_Amp}} = \frac{V_{\text{OUT\_Max}} - V_{\text{OUT\_Min}}}{R_{\text{SHUNT}} \times (I_{\text{MAX}} - I_{\text{MIN}})} = \frac{3.2 \text{ V} - 100 \text{ mV}}{100 \text{ m}\Omega \times [1 \text{ A} - (-1 \text{ A})]} = 15.5 \frac{\text{V}}{\text{V}} \quad (5)$$

The resistor value selected for R<sub>1</sub> and R<sub>3</sub> was 1 kΩ. 15.4 kΩ was selected for R<sub>2</sub> and R<sub>4</sub> because this number is the nearest standard value. Therefore, the ideal gain of the difference amplifier is 15.4 V/V.

The gain error of the circuit primarily depends on R<sub>1</sub> through R<sub>4</sub>. As a result of this dependence, 0.1% resistors were selected. This configuration reduces the likelihood that the design requires a two-point calibration. A simple one-point calibration, if desired, removes the offset errors introduced by the 0.5% resistors.

### 8.2.1.3 Application Curve

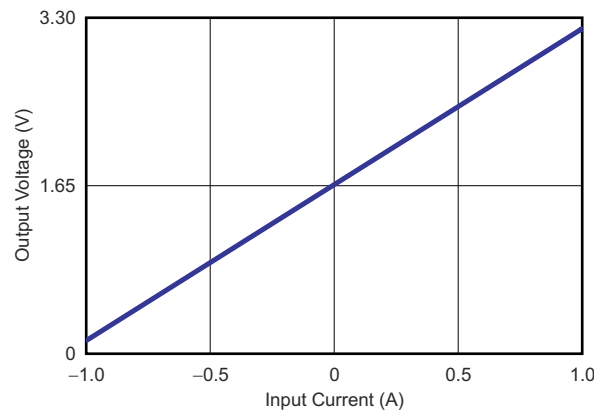

**图 8-2. Bidirectional Current-Sensing Circuit Performance: Output Voltage vs Input Current**

### 8.2.2 Single Operational Amplifier Bridge Amplifier

Figure 8-3 shows the basic configuration for a bridge amplifier.

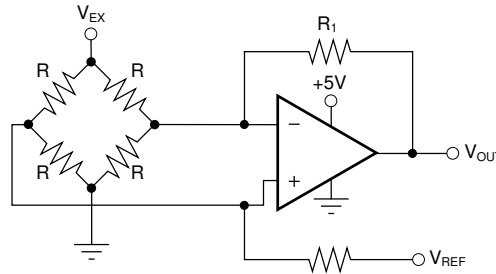

Copyright © 2016, Texas Instruments Incorporated

**Figure 8-3. Single Operational Amplifier Bridge Amplifier Schematic**

### 8.2.3 Precision, Low-Noise, DAC Buffer

The OPA388 can be used for a precision DAC buffer, as shown in Figure 8-4, in conjunction with the DAC8830.

The OPA388 provides an ultra-low drift, precision output buffer for the DAC. A wide range of DAC codes can be used in the linear region because the OPA388 employs zero-crossover technology. A precise reference is essential for maximum accuracy because the DAC8830 is a 16-bit converter.

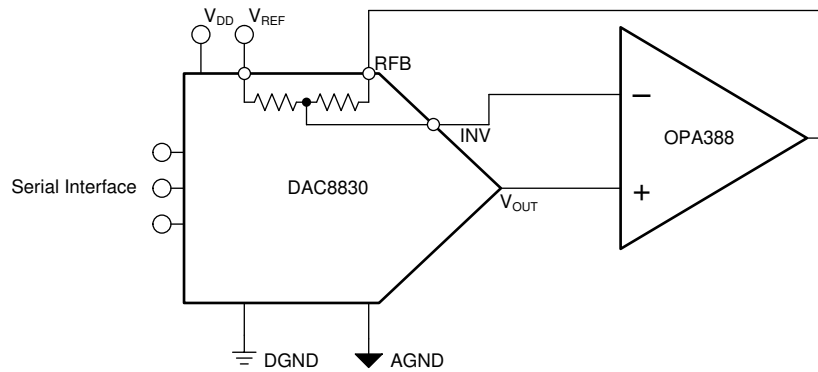

Copyright © 2016, Texas Instruments Incorporated

**Figure 8-4. Precision DAC Buffer**

### 8.2.4 Load Cell Measurement

Figure 8-5 shows the OPA388 in a high-CMRR dual-op amp instrumentation amplifier with a trim resistor and 6-wire load cell for precision measurement. Figure 8-6 illustrates the output voltage as a function of load cell resistance change, along with the nonlinearity of the system.

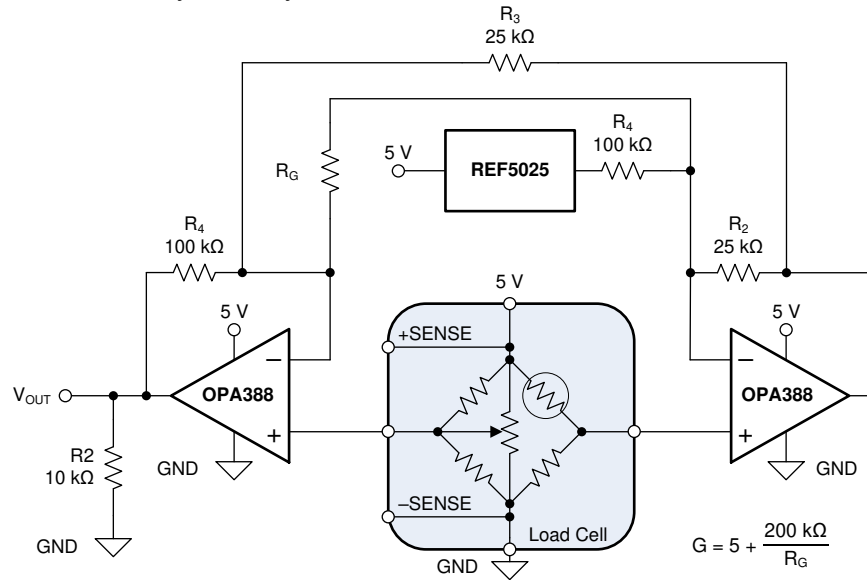

Figure 8-5. Load Cell Measurement Schematic

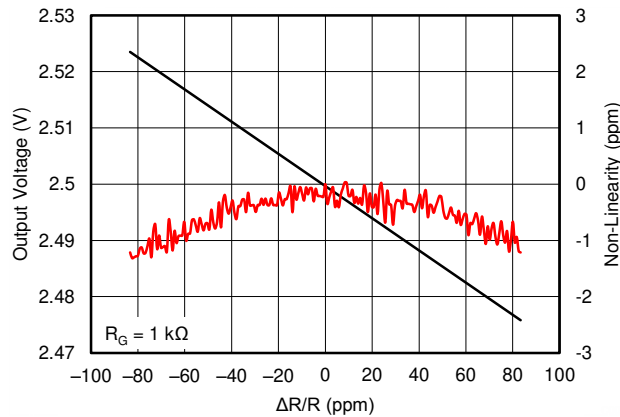

Figure 8-6. Load Cell Measurement Output

## 9 Power Supply Recommendations

The OPAx388 family of devices is specified for operation from 2.5 V to 5.5 V ( $\pm 1.25 \text{ V}$  to  $\pm 2.75 \text{ V}$ ). Parameters that can exhibit significant variance with regard to operating voltage are presented in the *Typical Characteristics* section.

## 10 Layout

### 10.1 Layout Guidelines

Paying attention to good layout practice is always recommended. Keep traces short and, when possible, use a printed-circuit board (PCB) ground plane with surface-mount components placed as close to the device pins as possible. Place a 0.1- $\mu\text{F}$  capacitor closely across the supply pins. These guidelines must be applied throughout the analog circuit to improve performance and provide benefits such as reducing the electromagnetic interference (EMI) susceptibility.

For lowest offset voltage and precision performance, circuit layout and mechanical conditions must be optimized. Avoid temperature gradients that create thermoelectric (Seebeck) effects in the thermocouple junctions formed from connecting dissimilar conductors. These thermally-generated potentials can be made to cancel by assuring they are equal on both input terminals. Other layout and design considerations include:

- Use low thermoelectric-coefficient conditions (avoid dissimilar metals).
- Thermally isolate components from power supplies or other heat sources.
- Shield operational amplifier and input circuitry from air currents, such as cooling fans.

Following these guidelines reduces the likelihood of junctions being at different temperatures, which can cause thermoelectric voltage drift of 0.1  $\mu\text{V}/^\circ\text{C}$  or higher, depending on materials used.

### 10.2 Layout Example

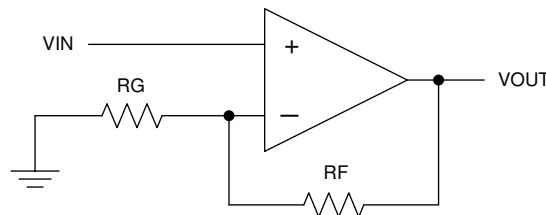

10-1. Schematic Representation

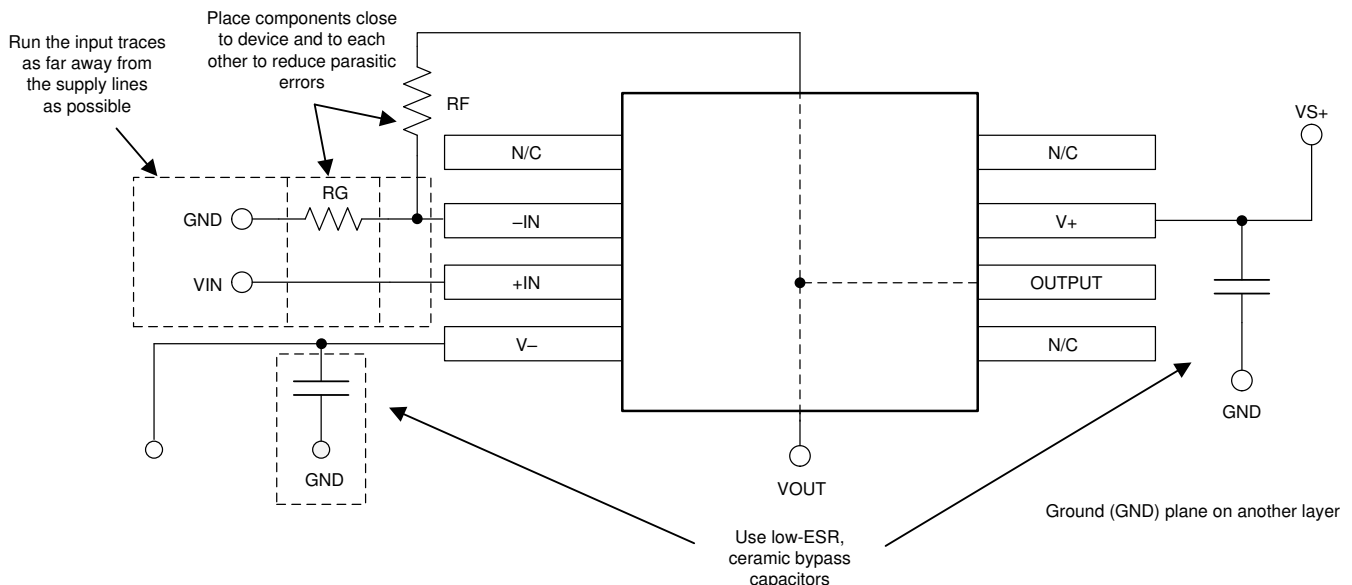

10-2. OPA388 Layout Example

## 11 Device and Documentation Support

### 11.1 Device Support

#### 11.1.1 Development Support

##### 11.1.1.1 TINA-TI™ (Free Software Download)

TINA-TI™ is a simple, powerful, and easy-to-use circuit simulation program based on a SPICE engine. TINA-TI™ is a free, fully-functional version of the TINA™ software, preloaded with a library of macromodels in addition to a range of both passive and active models. TINA-TI™ provides all the conventional dc, transient, and frequency domain analysis of SPICE, as well as additional design capabilities.

Available as a [free download](#) from the Analog eLab Design Center, TINA-TI™ offers extensive post-processing capability that allows users to format results in a variety of ways. Virtual instruments offer the ability to select input waveforms and probe circuit nodes, voltages, and waveforms, creating a dynamic quick-start tool.

---

#### Note

These files require that either the TINA software (from DesignSoft™) or TINA-TI™ software be installed. Download the free TINA-TI™ software from the [TINA-TI™ folder](#).

---

##### 11.1.1.2 TI Precision Designs

The OPAx388 family is featured on TI Precision Designs, available online at [www.ti.com/ww/en/analog/precision-designs/](http://www.ti.com/ww/en/analog/precision-designs/). TI Precision Designs are analog solutions created by TI's precision analog applications experts and offer the theory of operation, component selection, simulation, complete PCB schematic and layout, bill of materials, and measured performance of many useful circuits.

### 11.2 Documentation Support

#### 11.2.1 Related Documentation

For related documentation see the following:

- Texas Instruments, [Circuit board layout techniques](#)
- Texas Instruments, [DAC883x 16-Bit, Ultra-Low Power, Voltage-Output Digital-to-Analog Converters data sheet](#)

### 11.3 Related Links

表 11-1 lists quick access links. Categories include technical documents, support and community resources, tools and software, and quick access to sample or buy.

**Table 11-1. Related Links**

PARTS	PRODUCT FOLDER	SAMPLE & BUY	TECHNICAL DOCUMENTS	TOOLS & SOFTWARE	SUPPORT & COMMUNITY
OPA388	<a href="#">Click here</a>	<a href="#">Click here</a>	<a href="#">Click here</a>	<a href="#">Click here</a>	<a href="#">Click here</a>
OPA2388	<a href="#">Click here</a>	<a href="#">Click here</a>	<a href="#">Click here</a>	<a href="#">Click here</a>	<a href="#">Click here</a>
OPA4388	<a href="#">Click here</a>	<a href="#">Click here</a>	<a href="#">Click here</a>	<a href="#">Click here</a>	<a href="#">Click here</a>

## 11.4 Receiving Notification of Documentation Updates

To receive notification of documentation updates, navigate to the device product folder on ti.com. In the upper right corner, click on *Alert me* to register and receive a weekly digest of any product information that has changed. For change details, review the revision history included in any revised document.

## 11.5 Support Resources

[TI E2E™ support forums](#) are an engineer's go-to source for fast, verified answers and design help — straight from the experts. Search existing answers or ask your own question to get the quick design help you need.

Linked content is provided "AS IS" by the respective contributors. They do not constitute TI specifications and do not necessarily reflect TI's views; see TI's [Terms of Use](#).

## 11.6 Trademarks

TINA-TI™ are trademarks of TI.

TINA™ and DesignSoft™ are trademarks of DesignSoft, Inc.

TI E2E™ is a trademark of Texas Instruments.

All other trademarks are the property of their respective owners.

## 11.7 Electrostatic Discharge Caution



This integrated circuit can be damaged by ESD. Texas Instruments recommends that all integrated circuits be handled with appropriate precautions. Failure to observe proper handling and installation procedures can cause damage.

ESD damage can range from subtle performance degradation to complete device failure. Precision integrated circuits may be more susceptible to damage because very small parametric changes could cause the device not to meet its published specifications.

## 11.8 Glossary

[TI Glossary](#) This glossary lists and explains terms, acronyms, and definitions.

## 12 Mechanical, Packaging, and Orderable Information

The following pages include mechanical packaging and orderable information. This information is the most current data available for the designated devices. This data is subject to change without notice and revision of this document. For browser-based versions of this data sheet, refer to the left-hand navigation.

**PACKAGING INFORMATION**

Orderable part number	Status (1)	Material type (2)	Package   Pins	Package qty   Carrier	RoHS (3)	Lead finish/ Ball material (4)	MSL rating/ Peak reflow (5)	Op temp (°C)	Part marking (6)
<a href="#">OPA2388ID</a>	Active	Production	SOIC (D)   8	75   TUBE	Yes	SN	Level-2-260C-1 YEAR	-40 to 125	OP2388
OPA2388ID.B	Active	Production	SOIC (D)   8	75   TUBE	Yes	SN	Level-2-260C-1 YEAR	-40 to 125	OP2388
<a href="#">OPA2388IDGKR</a>	Active	Production	VSSOP (DGK)   8	2500   LARGE T&R	Yes	NIPDAU   SN	Level-2-260C-1 YEAR	-40 to 125	1D36
OPA2388IDGKR.B	Active	Production	VSSOP (DGK)   8	2500   LARGE T&R	Yes	NIPDAU	Level-2-260C-1 YEAR	-40 to 125	1D36
<a href="#">OPA2388IDGKT</a>	Active	Production	VSSOP (DGK)   8	250   SMALL T&R	Yes	NIPDAU   NIPDAUAG   SN	Level-2-260C-1 YEAR	-40 to 125	1D36
OPA2388IDGKT.B	Active	Production	VSSOP (DGK)   8	250   SMALL T&R	Yes	NIPDAU	Level-2-260C-1 YEAR	-40 to 125	1D36
<a href="#">OPA2388IDR</a>	Active	Production	SOIC (D)   8	2500   LARGE T&R	Yes	SN	Level-2-260C-1 YEAR	-40 to 125	OP2388
OPA2388IDR.B	Active	Production	SOIC (D)   8	2500   LARGE T&R	Yes	SN	Level-2-260C-1 YEAR	-40 to 125	OP2388
<a href="#">OPA388ID</a>	Active	Production	SOIC (D)   8	75   TUBE	Yes	NIPDAU	Level-2-260C-1 YEAR	-40 to 125	OPA388
OPA388ID.B	Active	Production	SOIC (D)   8	75   TUBE	Yes	NIPDAU	Level-2-260C-1 YEAR	-40 to 125	OPA388
<a href="#">OPA388IDBVR</a>	Active	Production	SOT-23 (DBV)   5	3000   LARGE T&R	Yes	NIPDAU	Level-2-260C-1 YEAR	-40 to 125	14KV
OPA388IDBVR.B	Active	Production	SOT-23 (DBV)   5	3000   LARGE T&R	Yes	NIPDAU	Level-2-260C-1 YEAR	-40 to 125	14KV
<a href="#">OPA388IDBVT</a>	Active	Production	SOT-23 (DBV)   5	250   SMALL T&R	Yes	NIPDAU	Level-2-260C-1 YEAR	-40 to 125	14KV
OPA388IDBVT.B	Active	Production	SOT-23 (DBV)   5	250   SMALL T&R	Yes	NIPDAU	Level-2-260C-1 YEAR	-40 to 125	14KV
OPA388IDBVTG4	Active	Production	SOT-23 (DBV)   5	250   SMALL T&R	Yes	NIPDAU	Level-2-260C-1 YEAR	-40 to 125	14KV
OPA388IDBVTG4.B	Active	Production	SOT-23 (DBV)   5	250   SMALL T&R	Yes	NIPDAU	Level-2-260C-1 YEAR	-40 to 125	14KV
<a href="#">OPA388IDGKR</a>	Active	Production	VSSOP (DGK)   8	2500   LARGE T&R	Yes	NIPDAUAG	Level-2-260C-1 YEAR	-40 to 125	14LV
OPA388IDGKR.B	Active	Production	VSSOP (DGK)   8	2500   LARGE T&R	Yes	NIPDAUAG	Level-2-260C-1 YEAR	-40 to 125	14LV
<a href="#">OPA388IDGKT</a>	Active	Production	VSSOP (DGK)   8	250   SMALL T&R	Yes	NIPDAUAG	Level-2-260C-1 YEAR	-40 to 125	14LV
OPA388IDGKT.B	Active	Production	VSSOP (DGK)   8	250   SMALL T&R	Yes	NIPDAUAG	Level-2-260C-1 YEAR	-40 to 125	14LV
<a href="#">OPA388IDR</a>	Active	Production	SOIC (D)   8	2500   LARGE T&R	Yes	NIPDAU	Level-2-260C-1 YEAR	-40 to 125	OPA388
OPA388IDR.B	Active	Production	SOIC (D)   8	2500   LARGE T&R	Yes	NIPDAU	Level-2-260C-1 YEAR	-40 to 125	OPA388
OPA388IDRG4	Active	Production	SOIC (D)   8	2500   LARGE T&R	Yes	NIPDAU	Level-2-260C-1 YEAR	-40 to 125	OPA388
OPA388IDRG4.B	Active	Production	SOIC (D)   8	2500   LARGE T&R	Yes	NIPDAU	Level-2-260C-1 YEAR	-40 to 125	OPA388
<a href="#">OPA4388ID</a>	Active	Production	SOIC (D)   14	50   TUBE	Yes	NIPDAU	Level-2-260C-1 YEAR	-40 to 125	OPA4388
OPA4388ID.B	Active	Production	SOIC (D)   14	50   TUBE	Yes	NIPDAU	Level-2-260C-1 YEAR	-40 to 125	OPA4388
<a href="#">OPA4388IDR</a>	Active	Production	SOIC (D)   14	2500   LARGE T&R	Yes	NIPDAU	Level-2-260C-1 YEAR	-40 to 125	OPA4388
OPA4388IDR.B	Active	Production	SOIC (D)   14	2500   LARGE T&R	Yes	NIPDAU	Level-2-260C-1 YEAR	-40 to 125	OPA4388

Orderable part number	Status (1)	Material type (2)	Package   Pins	Package qty   Carrier	RoHS (3)	Lead finish/ Ball material (4)	MSL rating/ Peak reflow (5)	Op temp (°C)	Part marking (6)
<a href="#">OPA4388IPW</a>	Active	Production	TSSOP (PW)   14	90   TUBE	Yes	NIPDAU	Level-2-260C-1 YEAR	-40 to 125	OPA4388
OPA4388IPW.B	Active	Production	TSSOP (PW)   14	90   TUBE	Yes	NIPDAU	Level-2-260C-1 YEAR	-40 to 125	OPA4388
<a href="#">OPA4388IPWR</a>	Active	Production	TSSOP (PW)   14	2000   LARGE T&R	Yes	NIPDAU	Level-2-260C-1 YEAR	-40 to 125	OPA4388
OPA4388IPWR.B	Active	Production	TSSOP (PW)   14	2000   LARGE T&R	Yes	NIPDAU	Level-2-260C-1 YEAR	-40 to 125	OPA4388

(1) **Status:** For more details on status, see our [product life cycle](#).

(2) **Material type:** When designated, preproduction parts are prototypes/experimental devices, and are not yet approved or released for full production. Testing and final process, including without limitation quality assurance, reliability performance testing, and/or process qualification, may not yet be complete, and this item is subject to further changes or possible discontinuation. If available for ordering, purchases will be subject to an additional waiver at checkout, and are intended for early internal evaluation purposes only. These items are sold without warranties of any kind.

(3) **RoHS values:** Yes, No, RoHS Exempt. See the [TI RoHS Statement](#) for additional information and value definition.

(4) **Lead finish/Ball material:** Parts may have multiple material finish options. Finish options are separated by a vertical ruled line. Lead finish/Ball material values may wrap to two lines if the finish value exceeds the maximum column width.

(5) **MSL rating/Peak reflow:** The moisture sensitivity level ratings and peak solder (reflow) temperatures. In the event that a part has multiple moisture sensitivity ratings, only the lowest level per JEDEC standards is shown. Refer to the shipping label for the actual reflow temperature that will be used to mount the part to the printed circuit board.

(6) **Part marking:** There may be an additional marking, which relates to the logo, the lot trace code information, or the environmental category of the part.

Multiple part markings will be inside parentheses. Only one part marking contained in parentheses and separated by a "-" will appear on a part. If a line is indented then it is a continuation of the previous line and the two combined represent the entire part marking for that device.

**Important Information and Disclaimer:**The information provided on this page represents TI's knowledge and belief as of the date that it is provided. TI bases its knowledge and belief on information provided by third parties, and makes no representation or warranty as to the accuracy of such information. Efforts are underway to better integrate information from third parties. TI has taken and continues to take reasonable steps to provide representative and accurate information but may not have conducted destructive testing or chemical analysis on incoming materials and chemicals. TI and TI suppliers consider certain information to be proprietary, and thus CAS numbers and other limited information may not be available for release.

In no event shall TI's liability arising out of such information exceed the total purchase price of the TI part(s) at issue in this document sold by TI to Customer on an annual basis.

**OTHER QUALIFIED VERSIONS OF OPA2388, OPA388 :**

- Automotive : [OPA2388-Q1](#), [OPA388-Q1](#)

NOTE: Qualified Version Definitions:

- Automotive - Q100 devices qualified for high-reliability automotive applications targeting zero defects

**TAPE AND REEL INFORMATION**

**QUADRANT ASSIGNMENTS FOR PIN 1 ORIENTATION IN TAPE**



\*All dimensions are nominal

Device	Package Type	Package Drawing	Pins	SPQ	Reel Diameter (mm)	Reel Width W1 (mm)	A0 (mm)	B0 (mm)	K0 (mm)	P1 (mm)	W (mm)	Pin1 Quadrant
OPA2388IDGKR	VSSOP	DGK	8	2500	330.0	12.4	5.3	3.4	1.4	8.0	12.0	Q1
OPA2388IDGKT	VSSOP	DGK	8	250	330.0	12.4	5.3	3.4	1.4	8.0	12.0	Q1
OPA2388IDGKT	VSSOP	DGK	8	250	330.0	12.4	5.25	3.35	1.25	8.0	12.0	Q1
OPA2388IDR	SOIC	D	8	2500	330.0	12.8	6.4	5.2	2.1	8.0	12.0	Q1
OPA388IDBVR	SOT-23	DBV	5	3000	180.0	8.4	3.23	3.17	1.37	4.0	8.0	Q3
OPA388IDBVT	SOT-23	DBV	5	250	180.0	8.4	3.23	3.17	1.37	4.0	8.0	Q3
OPA388IDBVTG4	SOT-23	DBV	5	250	180.0	8.4	3.23	3.17	1.37	4.0	8.0	Q3
OPA388IDGKR	VSSOP	DGK	8	2500	330.0	12.4	5.3	3.4	1.4	8.0	12.0	Q1
OPA388IDGKT	VSSOP	DGK	8	250	330.0	12.4	5.3	3.4	1.4	8.0	12.0	Q1
OPA388IDR	SOIC	D	8	2500	330.0	12.4	6.4	5.2	2.1	8.0	12.0	Q1
OPA388IDRG4	SOIC	D	8	2500	330.0	12.4	6.4	5.2	2.1	8.0	12.0	Q1
OPA4388IDR	SOIC	D	14	2500	330.0	16.4	6.5	9.0	2.1	8.0	16.0	Q1
OPA4388IPWR	TSSOP	PW	14	2000	330.0	12.4	6.9	5.6	1.6	8.0	12.0	Q1

**TAPE AND REEL BOX DIMENSIONS**

\*All dimensions are nominal

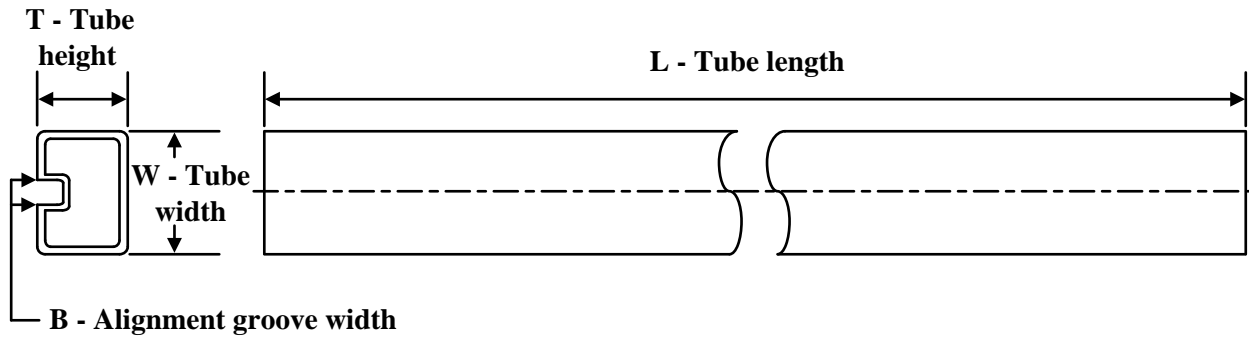
Device	Package Type	Package Drawing	Pins	SPQ	Length (mm)	Width (mm)	Height (mm)
OPA2388IDGKR	VSSOP	DGK	8	2500	353.0	353.0	32.0
OPA2388IDGKT	VSSOP	DGK	8	250	353.0	353.0	32.0
OPA2388IDGKT	VSSOP	DGK	8	250	366.0	364.0	50.0
OPA2388IDR	SOIC	D	8	2500	366.0	364.0	50.0
OPA388IDBVR	SOT-23	DBV	5	3000	213.0	191.0	35.0
OPA388IDBVT	SOT-23	DBV	5	250	213.0	191.0	35.0
OPA388IDBVTG4	SOT-23	DBV	5	250	213.0	191.0	35.0
OPA388IDGKR	VSSOP	DGK	8	2500	366.0	364.0	50.0
OPA388IDGKT	VSSOP	DGK	8	250	366.0	364.0	50.0
OPA388IDR	SOIC	D	8	2500	353.0	353.0	32.0
OPA388IDRG4	SOIC	D	8	2500	353.0	353.0	32.0
OPA4388IDR	SOIC	D	14	2500	353.0	353.0	32.0
OPA4388IPWR	TSSOP	PW	14	2000	353.0	353.0	32.0

**TUBE**

\*All dimensions are nominal

Device	Package Name	Package Type	Pins	SPQ	L (mm)	W (mm)	T (μm)	B (mm)
OPA2388ID	D	SOIC	8	75	517	7.87	635	4.25
OPA2388ID.B	D	SOIC	8	75	517	7.87	635	4.25
OPA388ID	D	SOIC	8	75	506.6	8	3940	4.32
OPA388ID.B	D	SOIC	8	75	506.6	8	3940	4.32
OPA4388ID	D	SOIC	14	50	506.6	8	3940	4.32
OPA4388ID.B	D	SOIC	14	50	506.6	8	3940	4.32
OPA4388IPW	PW	TSSOP	14	90	530	10.2	3600	3.5
OPA4388IPW.B	PW	TSSOP	14	90	530	10.2	3600	3.5



# EXAMPLE BOARD LAYOUT

DBV0005A

SOT-23 - 1.45 mm max height

SMALL OUTLINE TRANSISTOR



LAND PATTERN EXAMPLE  
EXPOSED METAL SHOWN  
SCALE:15X



SOLDER MASK DETAILS

4214839/K 08/2024

NOTES: (continued)

- 6. Publication IPC-7351 may have alternate designs.
- 7. Solder mask tolerances between and around signal pads can vary based on board fabrication site.

# EXAMPLE STENCIL DESIGN

DBV0005A

SOT-23 - 1.45 mm max height

SMALL OUTLINE TRANSISTOR



SOLDER PASTE EXAMPLE  
BASED ON 0.125 mm THICK STENCIL  
SCALE:15X

4214839/K 08/2024

NOTES: (continued)

8. Laser cutting apertures with trapezoidal walls and rounded corners may offer better paste release. IPC-7525 may have alternate design recommendations.
9. Board assembly site may have different recommendations for stencil design.

# DGK0008A



# PACKAGE OUTLINE

VSSOP - 1.1 mm max height

SMALL OUTLINE PACKAGE



**NOTES:**

PowerPAD is a trademark of Texas Instruments.

1. All linear dimensions are in millimeters. Any dimensions in parenthesis are for reference only. Dimensioning and tolerancing per ASME Y14.5M.
2. This drawing is subject to change without notice.
3. This dimension does not include mold flash, protrusions, or gate burrs. Mold flash, protrusions, or gate burrs shall not exceed 0.15 mm per side.
4. This dimension does not include interlead flash. Interlead flash shall not exceed 0.25 mm per side.
5. Reference JEDEC registration MO-187.

# EXAMPLE BOARD LAYOUT

DGK0008A

™ VSSOP - 1.1 mm max height

SMALL OUTLINE PACKAGE



LAND PATTERN EXAMPLE  
EXPOSED METAL SHOWN  
SCALE: 15X



SOLDER MASK DETAILS

4214862/A 04/2023

NOTES: (continued)

6. Publication IPC-7351 may have alternate designs.
7. Solder mask tolerances between and around signal pads can vary based on board fabrication site.
8. Vias are optional depending on application, refer to device data sheet. If any vias are implemented, refer to their locations shown on this view. It is recommended that vias under paste be filled, plugged or tented.
9. Size of metal pad may vary due to creepage requirement.

# EXAMPLE STENCIL DESIGN

DGK0008A

<sup>TM</sup> VSSOP - 1.1 mm max height

SMALL OUTLINE PACKAGE



SOLDER PASTE EXAMPLE  
SCALE: 15X

4214862/A 04/2023

NOTES: (continued)

11. Laser cutting apertures with trapezoidal walls and rounded corners may offer better paste release. IPC-7525 may have alternate design recommendations.
12. Board assembly site may have different recommendations for stencil design.



# D0014A

# PACKAGE OUTLINE

## SOIC - 1.75 mm max height

SMALL OUTLINE INTEGRATED CIRCUIT



### NOTES:

1. All linear dimensions are in millimeters. Dimensions in parenthesis are for reference only. Dimensioning and tolerancing per ASME Y14.5M.
2. This drawing is subject to change without notice.
3. This dimension does not include mold flash, protrusions, or gate burrs. Mold flash, protrusions, or gate burrs shall not exceed 0.15 mm, per side.
4. This dimension does not include interlead flash. Interlead flash shall not exceed 0.43 mm, per side.
5. Reference JEDEC registration MS-012, variation AB.



# EXAMPLE STENCIL DESIGN

D0014A

SOIC - 1.75 mm max height

SMALL OUTLINE INTEGRATED CIRCUIT



SOLDER PASTE EXAMPLE  
BASED ON 0.125 mm THICK STENCIL  
SCALE:8X

4220718/A 09/2016

NOTES: (continued)

8. Laser cutting apertures with trapezoidal walls and rounded corners may offer better paste release. IPC-7525 may have alternate design recommendations.
9. Board assembly site may have different recommendations for stencil design.



D0008A

# PACKAGE OUTLINE

SOIC - 1.75 mm max height

SMALL OUTLINE INTEGRATED CIRCUIT



NOTES:

1. Linear dimensions are in inches [millimeters]. Dimensions in parenthesis are for reference only. Controlling dimensions are in inches. Dimensioning and tolerancing per ASME Y14.5M.
2. This drawing is subject to change without notice.
3. This dimension does not include mold flash, protrusions, or gate burrs. Mold flash, protrusions, or gate burrs shall not exceed  $.006$  [0.15] per side.
4. This dimension does not include interlead flash.
5. Reference JEDEC registration MS-012, variation AA.

# EXAMPLE BOARD LAYOUT

D0008A

SOIC - 1.75 mm max height

SMALL OUTLINE INTEGRATED CIRCUIT



LAND PATTERN EXAMPLE  
 EXPOSED METAL SHOWN  
 SCALE:8X



SOLDER MASK DETAILS

4214825/C 02/2019

NOTES: (continued)

- 6. Publication IPC-7351 may have alternate designs.
- 7. Solder mask tolerances between and around signal pads can vary based on board fabrication site.

# EXAMPLE STENCIL DESIGN

D0008A

SOIC - 1.75 mm max height

SMALL OUTLINE INTEGRATED CIRCUIT



SOLDER PASTE EXAMPLE  
BASED ON .005 INCH [0.125 MM] THICK STENCIL  
SCALE:8X

4214825/C 02/2019

NOTES: (continued)

8. Laser cutting apertures with trapezoidal walls and rounded corners may offer better paste release. IPC-7525 may have alternate design recommendations.
9. Board assembly site may have different recommendations for stencil design.



4220202/B 12/2023

NOTES:

1. All linear dimensions are in millimeters. Any dimensions in parenthesis are for reference only. Dimensioning and tolerancing per ASME Y14.5M.
2. This drawing is subject to change without notice.
3. This dimension does not include mold flash, protrusions, or gate burrs. Mold flash, protrusions, or gate burrs shall not exceed 0.15 mm per side.
4. This dimension does not include interlead flash. Interlead flash shall not exceed 0.25 mm per side.
5. Reference JEDEC registration MO-153.

# EXAMPLE BOARD LAYOUT

PW0014A

TSSOP - 1.2 mm max height

SMALL OUTLINE PACKAGE



LAND PATTERN EXAMPLE  
EXPOSED METAL SHOWN  
SCALE: 10X



4220202/B 12/2023

NOTES: (continued)

6. Publication IPC-7351 may have alternate designs.
7. Solder mask tolerances between and around signal pads can vary based on board fabrication site.

# EXAMPLE STENCIL DESIGN

PW0014A

TSSOP - 1.2 mm max height

SMALL OUTLINE PACKAGE



SOLDER PASTE EXAMPLE  
BASED ON 0.125 mm THICK STENCIL  
SCALE: 10X

4220202/B 12/2023

NOTES: (continued)

8. Laser cutting apertures with trapezoidal walls and rounded corners may offer better paste release. IPC-7525 may have alternate design recommendations.
9. Board assembly site may have different recommendations for stencil design.

## 重要なお知らせと免責事項

TI は、技術データと信頼性データ(データシートを含みます)、設計リソース(リファレンス デザインを含みます)、アプリケーションや設計に関する各種アドバイス、Web ツール、安全性情報、その他のリソースを、欠陥が存在する可能性のある「現状のまま」提供しており、商品性および特定目的に対する適合性の黙示保証、第三者の知的財産権の非侵害保証を含むいかなる保証も、明示的または黙示的にかかわらず拒否します。

これらのリソースは、TI 製品を使用する設計の経験を積んだ開発者への提供を意図したものです。(1) お客様のアプリケーションに適した TI 製品の選定、(2) お客様のアプリケーションの設計、検証、試験、(3) お客様のアプリケーションに該当する各種規格や、その他のあらゆる安全性、セキュリティ、規制、または他の要件への確実な適合に関する責任を、お客様のみが単独で負うものとし、

上記の各種リソースは、予告なく変更される可能性があります。これらのリソースは、リソースで説明されている TI 製品を使用するアプリケーションの開発の目的でのみ、TI はその使用をお客様に許諾します。これらのリソースに関して、他の目的で複製することや掲載することは禁止されています。TI や第三者の知的財産権のライセンスが付与されている訳ではありません。お客様は、これらのリソースを自身で使用した結果発生するあらゆる申し立て、損害、費用、損失、責任について、TI およびその代理人を完全に補償するものとし、TI は一切の責任を拒否します。

TI の製品は、[TI の販売条件](#)、[TI の総合的な品質ガイドライン](#)、[ti.com](#) または TI 製品などに関連して提供される他の適用条件に従い提供されます。TI がこれらのリソースを提供することは、適用される TI の保証または他の保証の放棄の拡大や変更を意味するものではありません。TI がカスタム、またはカスタマー仕様として明示的に指定していない限り、TI の製品は標準的なカタログに掲載される汎用機器です。

お客様がいかなる追加条項または代替条項を提案する場合も、TI はそれらに異議を唱え、拒否します。

Copyright © 2026, Texas Instruments Incorporated

最終更新日 : 2025 年 10 月