

OPAx172-Q1 36V、単一電源、10MHz、レール・ツー・レール出力、 車載用グレード・オペアンプ

1 特長

- 車載アプリケーションに対応
- 下記内容でAEC-Q100認定済み：
 - デバイス温度グレード 1:
 - 動作時周囲温度範囲-40°C～+125°C
 - デバイスHBM ESD分類レベル3A
 - デバイスCDM ESD分類レベルC6
- 広い電源電圧範囲:
 - 4.5V～36V, $\pm 2.25V \sim \pm 18V$
- 低いオフセット電圧: $\pm 0.2mV$
- 低いオフセット・ドリフト: $\pm 0.3\mu V/^\circ C$
- ゲイン帯域幅: 10MHz
- 低い入力バイアス電流: $\pm 8pA$
- 低い静止電流: アンプごとに1.6mA
- 低ノイズ: $7nV/\sqrt{Hz}$
- EMIおよびRFIフィルタ入力
- 入力範囲は負の電源電圧にも対応
- 入力範囲は正の電源電圧まで動作
- レール・ツー・レール出力
- 高い同相除去: 120dB
- 業界標準のパッケージ
 - VSSOP-8, TSSOP-14

2 アプリケーション

- 車載
- HEVおよびEVパワートレイン
- 先進運転支援システム (ADAS)
- 自動気候制御
- 航空電子工学、着陸装置
- 医療用計測機器
- 電流感知

優れたTHD性能

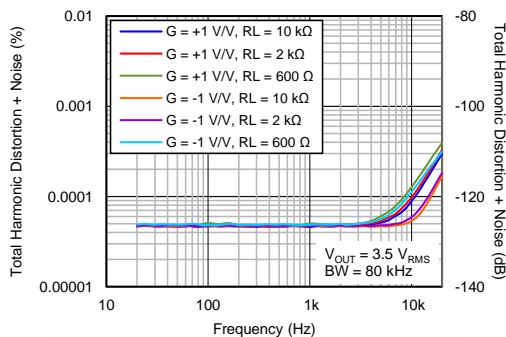

3 概要

OPA2172-Q1, OPA4172-Q1 (OPAx172-Q1)は36V、単一電源、低ノイズのオペアンプのファミリーで、4.5V ($\pm 2.25V$)～36V ($\pm 18V$)の範囲の電源で動作できます。

OPAx172-Q1はマイクロパッケージで供給され、低いオフセット、ドリフト係数、静止電流を実現します。広い帯域幅、高速なスルー・レート、高い出力電流駆動能力も、これらのデバイスの特長です。デュアルおよびクワッドの各バージョンは、いずれも同一仕様で、可能な限り柔軟に設計を行えます。

ほとんどのオペアンプでは1つの電源電圧でしか動作が規定されていないのに対して、OPAx172-Q1ファミリーは4.5V～36Vでの動作が規定されています。電源レールの範囲外の入力信号が位相反転を起こすことはありません。通常の動作時に、入力は負のレールより100mV下、および上限レールの2V以内で動作できます。これらのデバイスは完全なレール・ツー・レール入力で、上限レールを100mV超えて動作しますが、上限レールから2V以内では性能が低下することに注意してください。

OPAx172-Q1シリーズのオペアンプは、-40°C～+125°Cでの動作が規定されています。

製品情報⁽¹⁾

型番	パッケージ	本体サイズ(公称)
OPA2172-Q1	VSSOP (8)	3.00mmx3.00mm
OPA4172-Q1	TSSOP (14)	5.00mmx4.40mm

(1) 提供されているすべてのパッケージについては、データシートの末尾にある注文情報を参照してください。

JFET入力の低ノイズ・アンプ

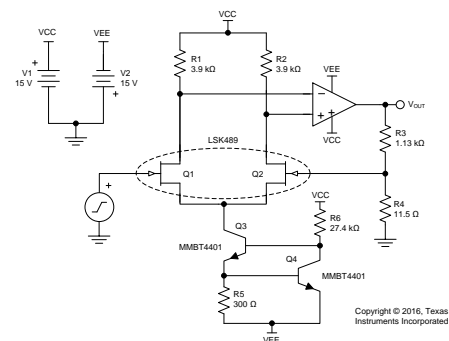

目次

1	特長	1	9	Applications and Implementation	20
2	アプリケーション	1	9.1	Application Information.....	20
3	概要	1	9.2	Typical Applications	20
4	改訂履歴	2	10	Power Supply Recommendations	24
5	Device Comparison Table	3	11	Layout	24
6	Pin Configuration and Functions	3	11.1	Layout Guidelines	24
7	Specifications	4	11.2	Layout Example	25
7.1	Absolute Maximum Ratings	4	12	デバイスおよびドキュメントのサポート	26
7.2	ESD Ratings.....	4	12.1	デバイス・サポート.....	26
7.3	Recommended Operating Conditions.....	4	12.2	ドキュメントのサポート.....	26
7.4	Thermal Information	4	12.3	関連リンク	26
7.5	Electrical Characteristics.....	5	12.4	ドキュメントの更新通知を受け取る方法.....	26
7.6	Typical Characteristics.....	7	12.5	コミュニティ・リソース	27
8	Detailed Description	14	12.6	商標	27
8.1	Overview	14	12.7	静電気放電に関する注意事項	27
8.2	Functional Block Diagram	14	12.8	Glossary	27
8.3	Feature Description.....	15	13	メカニカル、パッケージ、および注文情報	27
8.4	Device Functional Modes.....	17			

4 改訂履歴

資料番号末尾の英字は改訂を表しています。その改訂履歴は英語版に準じています。

2016年11月発行のものから更新		Page
•	データシート全体を通してOPA172-Q1を削除.....	1
•	Deleted Operating temperature, T_A from <i>Absolute Maximum Ratings</i>	4
•	Added OPA4172-Q1 in PW package to <i>ESD Ratings</i> table.....	4
•	Changed values in the <i>Thermal Information</i> table to align with JEDEC standards.	4
•	Deleted value: ± 14 and temperature range: $T_A = -40^\circ\text{C}$ to $+125^\circ\text{C}$ from Input bias current and added $T_A = 25^\circ\text{C}$ to Input bias current and Input offset current.....	5
•	Changed TYP value from: 2.5 to: 2 for Input voltage noise, E_n	5
•	Deleted Specified temperature from <i>Electrical Characteristics</i> table	6
•	Changed figure: <i>Operational Amplifier Board Layout for a Noninverting Configuration</i> with revised content.....	25

5 Device Comparison Table

Table 1. Device Comparison

DEVICE	PACKAGE
OPA2172-Q1 (dual)	VSSOP-8
OPA4172-Q1 (quad)	TSSOP-14

Table 2. Device Family Comparison

DEVICE	QUIESCENT CURRENT (I_Q)	GAIN BANDWIDTH PRODUCT (GBP)	VOLTAGE NOISE DENSITY (e_n)
OPAx172	1600 μ A	10 MHz	7 nV/ $\sqrt{\text{Hz}}$
OPAx171	475 μ A	3.0 MHz	14 nV/ $\sqrt{\text{Hz}}$
OPAx170	110 μ A	1.2 MHz	19 nV/ $\sqrt{\text{Hz}}$

6 Pin Configuration and Functions

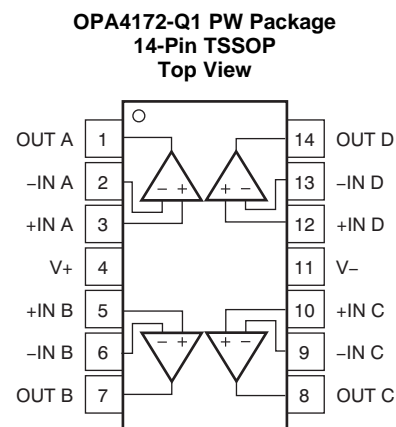
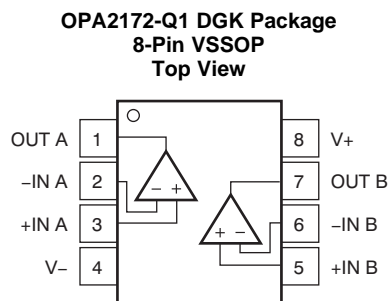

Pin Functions

NAME	PIN		I/O	DESCRIPTION
	OPA2172-Q1 DGK (VSSOP)	OPA4172-Q1 PW (TSSOP)		
-IN A	2	2	I	Inverting input, channel A
-IN B	6	6	I	Inverting input, channel B
-IN C	—	9	I	Inverting input, channel C
-IN D	—	13	I	Inverting input, channel D
+IN A	3	3	I	Noninverting input, channel A
+IN B	5	5	I	Noninverting input, channel B
+IN C	—	10	I	Noninverting input, channel C
+IN D	—	12	I	Noninverting input, channel D
OUT A	1	1	O	Output, channel A
OUT B	7	7	O	Output, channel B
OUT C	—	8	O	Output, channel C
OUT D	—	14	O	Output, channel D
V-	4	11	—	Negative (lowest) power supply
V+	8	4	—	Positive (highest) power supply

7 Specifications

7.1 Absolute Maximum Ratings

 over operating free-air temperature range (unless otherwise noted)⁽¹⁾

		MIN	MAX	UNIT	
Voltage	Supply voltage, V+ to V–	–20	20	V	
	Single-supply voltage		40		
	Signal input pins voltage ⁽²⁾	Common-mode	(V–) – 0.5		(V+) + 0.5
		Differential ⁽³⁾	–0.5		0.5
Current	Signal input pins current	–10	10	mA	
	Output short-circuit ⁽⁴⁾	Continuous			
Temperature	Junction, T _J		150	°C	
	Storage, T _{stg}	–65	150		

(1) Stresses beyond those listed under *Absolute Maximum Ratings* may cause permanent damage to the device. These are stress ratings only, which do not imply functional operation of the device at these or any other conditions beyond those indicated under *Recommended Operating Conditions*. Exposure to absolute-maximum-rated conditions for extended periods may affect device reliability.

(2) Transient conditions that exceed these voltage ratings must be current limited to 10 mA or less.

(3) Refer to the [Electrical Overstress](#) section for more information.

(4) Short-circuit to ground, one amplifier per package.

7.2 ESD Ratings

			VALUE	UNIT
OPA2172-Q1 in DGK package				
V _(ESD)	Electrostatic discharge	Human-body model (HBM), per AEC Q100-002 ⁽¹⁾	±4000	V
		Charged-device model (CDM), per AEC Q100-011	±1000	
OPA4172-Q1 in PW package				
V _(ESD)	Electrostatic discharge	Human-body model (HBM), per AEC Q100-002 ⁽¹⁾	±4000	V
		Charged-device model (CDM), per AEC Q100-011	±750	

(1) AEC Q100-002 indicates that HBM stressing shall be in accordance with the ANSI/ESDA/JEDEC JS-001 specification.

7.3 Recommended Operating Conditions

over operating free-air temperature range (unless otherwise noted)

		MIN	MAX	UNIT
Supply voltage, (V+) – (V–)	Single-supply	4.5	36	V
	Dual-supply	±2.25	±18	
Specified temperature		–40	125	°C

7.4 Thermal Information

THERMAL METRIC ⁽¹⁾		OPA2172-Q1	OPA4172-Q1	UNIT
		DGK (VSSOP)	PW (TSSOP)	
		8 PINS	14 PINS	
R _{θJA}	Junction-to-ambient thermal resistance	181.4	107.5	°C/W
R _{θJC(top)}	Junction-to-case (top) thermal resistance	69.2	32.5	°C/W
R _{θJB}	Junction-to-board thermal resistance	103.3	50.4	°C/W
ψ _{JT}	Junction-to-top characterization parameter	10.9	1.8	°C/W
ψ _{JB}	Junction-to-board characterization parameter	101.6	49.6	°C/W
R _{θJC(bot)}	Junction-to-case (bottom) thermal resistance	N/A	N/A	°C/W

(1) For more information about traditional and new thermal metrics, see the [Semiconductor and IC Package Thermal Metrics](#) application report.

7.5 Electrical Characteristics

at $T_A = 25^\circ\text{C}$, $V_S = \pm 2.25\text{ V}$ to $\pm 18\text{ V}$, $V_{CM} = V_{OUT} = V_S / 2$, and $R_L = 10\text{ k}\Omega$ connected to $V_S / 2$ (unless otherwise noted)

PARAMETER		TEST CONDITIONS		MIN	TYP	MAX	UNIT	
OFFSET VOLTAGE								
V_{OS}	Input offset voltage			± 0.2		± 1	mV	
		$T_A = -40^\circ\text{C}$ to $+125^\circ\text{C}$				± 1.15		
dV_{OS}/dT	Input offset voltage drift	$T_A = -40^\circ\text{C}$ to $+125^\circ\text{C}$	OPA4172-Q1	± 0.3		± 1.5	$\mu\text{V}/^\circ\text{C}$	
			OPA2172-Q1			± 1.8		
PSRR	Power-supply rejection ratio	$T_A = -40^\circ\text{C}$ to $+125^\circ\text{C}$			± 1	± 3	$\mu\text{V}/\text{V}$	
	Channel separation, dc	At dc			5		$\mu\text{V}/\text{V}$	
INPUT BIAS CURRENT								
I_B	Input bias current	$T_A = 25^\circ\text{C}$			± 8	± 15	μA	
		$T_A = -40^\circ\text{C}$ to $+125^\circ\text{C}$	OPA2172-Q1IDGK				± 18	nA
			OPA4172-Q11PW					
I_{OS}	Input offset current	$T_A = 25^\circ\text{C}$			± 2	± 15	μA	
		$T_A = -40^\circ\text{C}$ to $+125^\circ\text{C}$	OPA4172-Q1			± 1	nA	
			OPA2172-Q1			± 3		
NOISE								
E_n	Input voltage noise	$f = 0.1\text{ Hz}$ to 10 Hz			2		μV_{PP}	
e_n	Input voltage noise density	$f = 100\text{ Hz}$			12		$\text{nV}/\sqrt{\text{Hz}}$	
		$f = 1\text{ kHz}$			7			
i_n	Input current noise density	$f = 1\text{ kHz}$			1.6		$\text{fA}/\sqrt{\text{Hz}}$	
INPUT VOLTAGE								
V_{CM}	Common-mode voltage ⁽¹⁾			$(V-) - 0.1\text{ V}$		$(V+) - 2\text{ V}$	V	
CMRR	Common-mode rejection ratio	$V_S = \pm 2.25\text{ V}$, $(V-) - 0.1\text{ V} < V_{CM} < (V+) - 2\text{ V}$, $T_A = -40^\circ\text{C}$ to $+125^\circ\text{C}$		90	104		dB	
		$V_S = \pm 18\text{ V}$, $(V-) - 0.1\text{ V} < V_{CM} < (V+) - 2\text{ V}$, $T_A = -40^\circ\text{C}$ to $+125^\circ\text{C}$		110	120			
INPUT IMPEDANCE								
	Differential				$100 \parallel 4$		$\text{M}\Omega \parallel \text{pF}$	
	Common-mode				$6 \parallel 4$		$10^{13}\Omega \parallel \text{pF}$	
OPEN-LOOP GAIN								
A_{OL}	Open-loop voltage gain	$(V-) + 0.35\text{ V} < V_O < (V+) - 0.35\text{ V}$, $R_L = 10\text{ k}\Omega$, $T_A = -40^\circ\text{C}$ to $+125^\circ\text{C}$	OPA4172-Q1	110	130		dB	
			OPA2172-Q1	107	115			
		$(V-) + 0.5\text{ V} < V_O < (V+) - 0.5\text{ V}$, $R_L = 2\text{ k}\Omega$, $T_A = -40^\circ\text{C}$ to $+125^\circ\text{C}$	OPA4172-Q1			116		
			OPA2172-Q1			107		
FREQUENCY RESPONSE								
GBP	Gain bandwidth product				10		MHz	
SR	Slew rate	$G = 1$			10		$\text{V}/\mu\text{s}$	
t_s	Settling time	To 0.1%, $V_S = \pm 18\text{ V}$, $G = 1$, 10-V step			2		μs	
		To 0.01% (12 bit), $V_S = \pm 18\text{ V}$, $G = 1$, 10-V step			3.2			
	Overload recovery time	$V_{IN} \times \text{Gain} > V_S$			200		ns	
THD+N	Total harmonic distortion + noise	$V_S = 36\text{ V}$, $G = 1$, $f = 1\text{ kHz}$, $V_O = 3.5\text{ V}_{RMS}$			0.00005%			

- (1) The input range can be extended beyond $(V+) - 2\text{ V}$ up to $(V+) + 0.1\text{ V}$. See the [Typical Characteristics](#) and [Application Information](#) sections for additional information.

OPA2172-Q1, OPA4172-Q1

JAJSCN7A –NOVEMBER 2016–REVISED JUNE 2017

www.ti.com
Electrical Characteristics (continued)

 at $T_A = 25^\circ\text{C}$, $V_S = \pm 2.25\text{ V}$ to $\pm 18\text{ V}$, $V_{CM} = V_{OUT} = V_S / 2$, and $R_L = 10\text{ k}\Omega$ connected to $V_S / 2$ (unless otherwise noted)

PARAMETER		TEST CONDITIONS		MIN	TYP	MAX	UNIT
OUTPUT							
V_O	Voltage output swing from rail	$V_S = +36\text{ V}$	$R_L = 10\text{ k}\Omega$		70	90	mV
			$R_L = 2\text{ k}\Omega$		330	400	
		$V_S = +36\text{ V}$, $T_A = -40^\circ\text{C}$ to $+125^\circ\text{C}$	$R_L = 10\text{ k}\Omega$		95	120	
			$R_L = 2\text{ k}\Omega$		470	530	
		$V_S = 4.5\text{ V}$	$R_L = 10\text{ k}\Omega$		10	20	
			$R_L = 2\text{ k}\Omega$		40	50	
$V_S = 4.5\text{ V}$, $T_A = -40^\circ\text{C}$ to $+125^\circ\text{C}$	$R_L = 10\text{ k}\Omega$		10	25			
	$R_L = 2\text{ k}\Omega$		55	70			
I_{SC}	Short-circuit current			± 75			mA
C_{LOAD}	Capacitive load drive			See the Typical Characteristics			pF
Z_O	Open-loop output impedance	$f = 1\text{ MHz}$, $I_O = 0\text{ A}$		60			Ω
POWER SUPPLY							
V_S	Specified voltage			4.5		36	V
I_Q	Quiescent current per amplifier	$I_O = 0\text{ A}$			1.6	1.8	mA
		$I_O = 0\text{ A}$, $T_A = -40^\circ\text{C}$ to $+125^\circ\text{C}$				2	

7.6 Typical Characteristics

at $V_S = \pm 18\text{ V}$, $V_{CM} = V_S / 2$, $R_{LOAD} = 10\text{ k}\Omega$ connected to $V_S / 2$, and $C_L = 100\text{ pF}$ (unless otherwise noted)

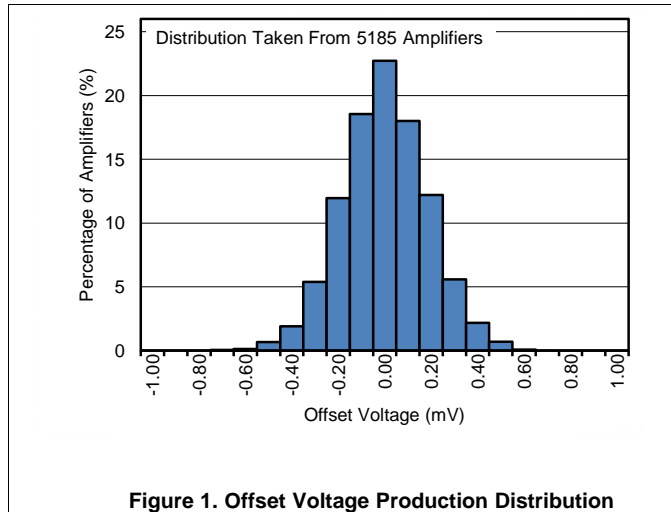

Figure 1. Offset Voltage Production Distribution

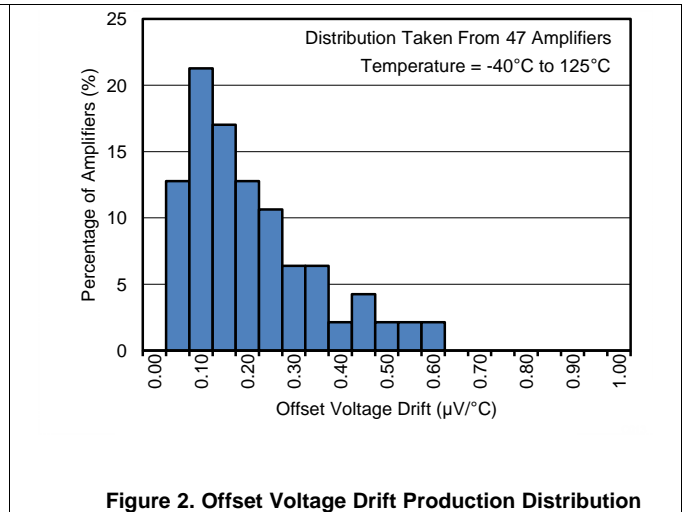

Figure 2. Offset Voltage Drift Production Distribution

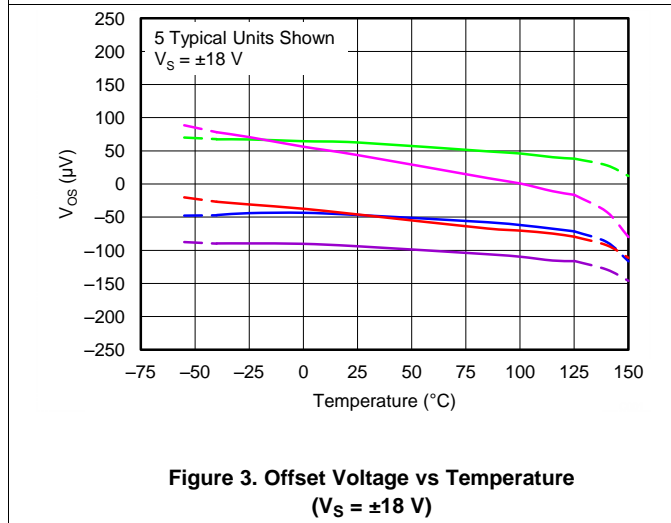

Figure 3. Offset Voltage vs Temperature
($V_S = \pm 18\text{ V}$)

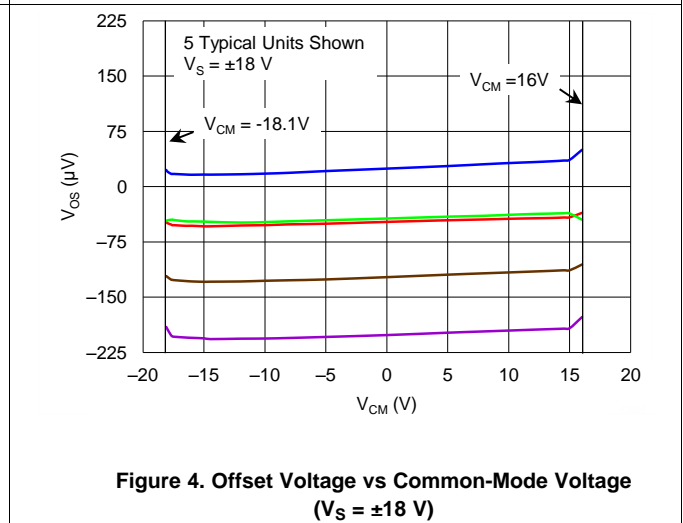

Figure 4. Offset Voltage vs Common-Mode Voltage
($V_S = \pm 18\text{ V}$)

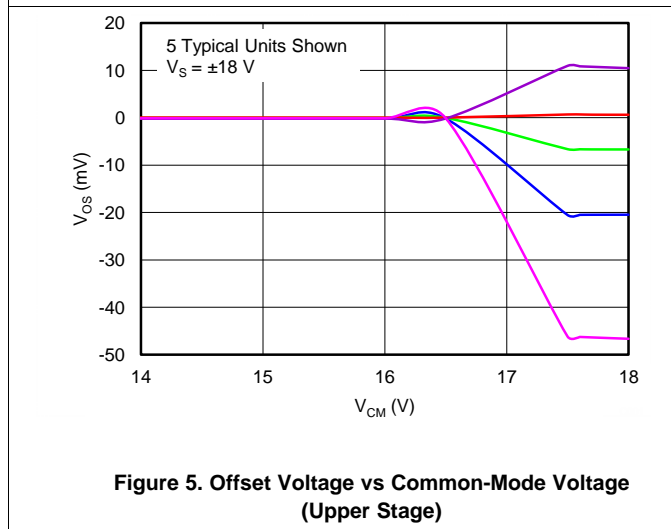

Figure 5. Offset Voltage vs Common-Mode Voltage
(Upper Stage)

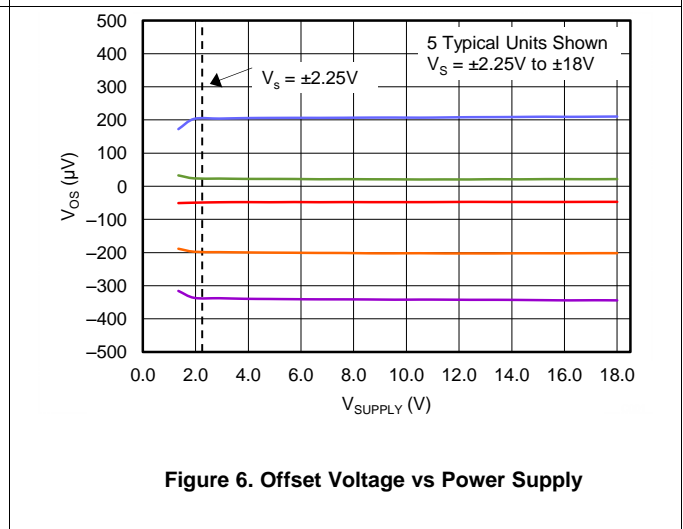

Figure 6. Offset Voltage vs Power Supply

Typical Characteristics (continued)

at $V_S = \pm 18\text{ V}$, $V_{CM} = V_S / 2$, $R_{LOAD} = 10\text{ k}\Omega$ connected to $V_S / 2$, and $C_L = 100\text{ pF}$ (unless otherwise noted)

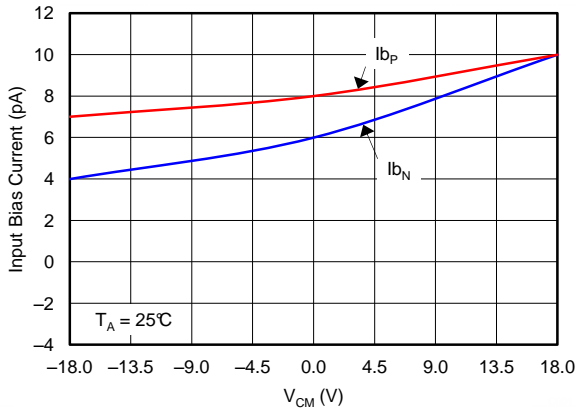

Figure 7. Input Bias Current vs Common-Mode Voltage

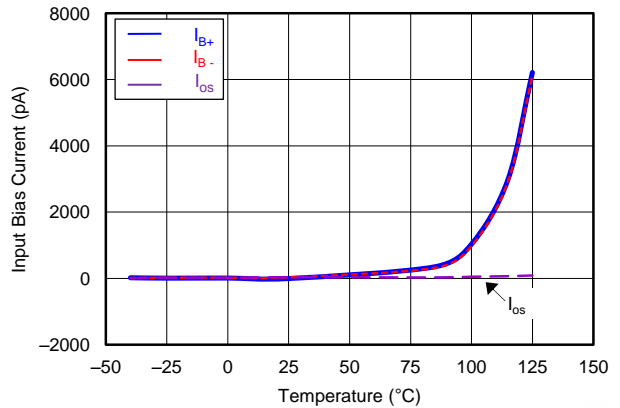

Figure 8. Input Bias Current vs Temperature

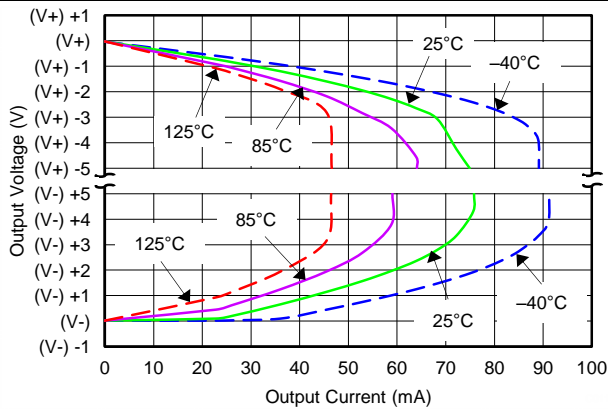

Figure 9. Output Voltage Swing vs Output Current (Maximum Supply)

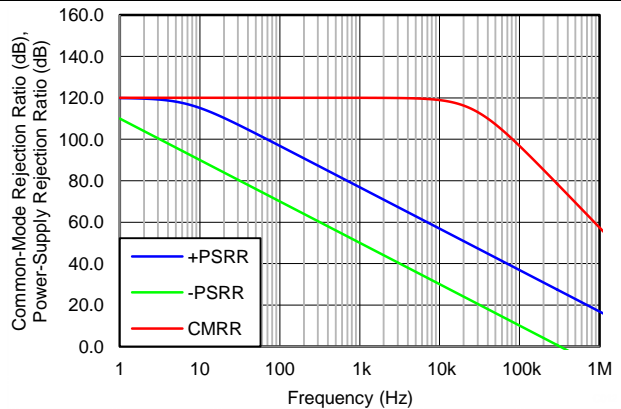

Figure 10. CMRR and PSRR vs Frequency (Referred-to-Input)

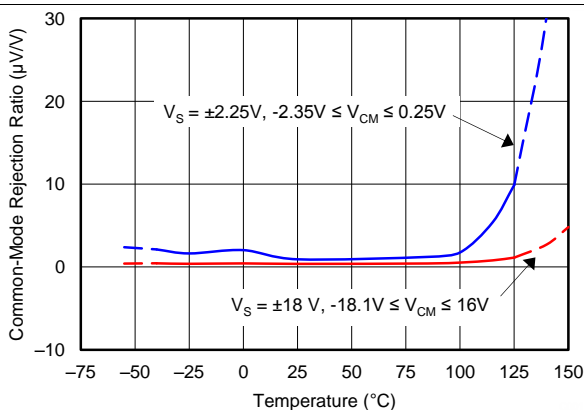

Figure 11. CMRR vs Temperature

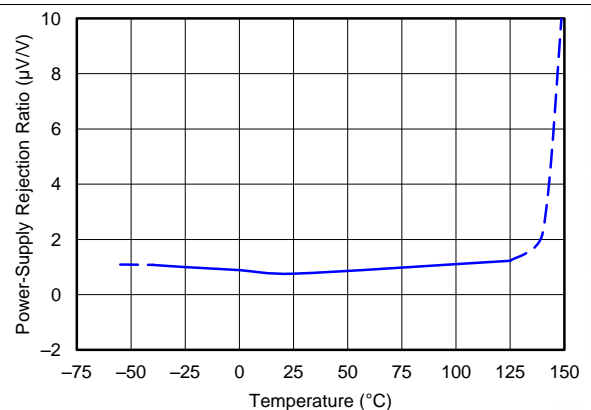

Figure 12. PSRR vs Temperature

Typical Characteristics (continued)

at $V_S = \pm 18\text{ V}$, $V_{CM} = V_S / 2$, $R_{LOAD} = 10\text{ k}\Omega$ connected to $V_S / 2$, and $C_L = 100\text{ pF}$ (unless otherwise noted)

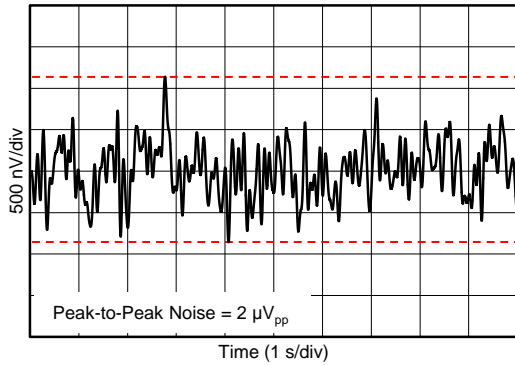

Figure 13. 0.1-Hz to 10-Hz Noise

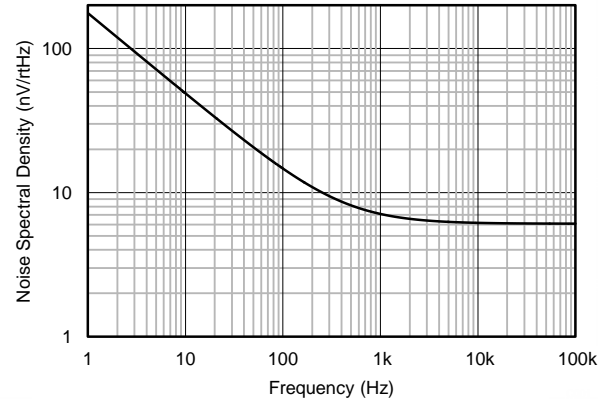

Figure 14. Input Voltage Noise Spectral Density vs Frequency

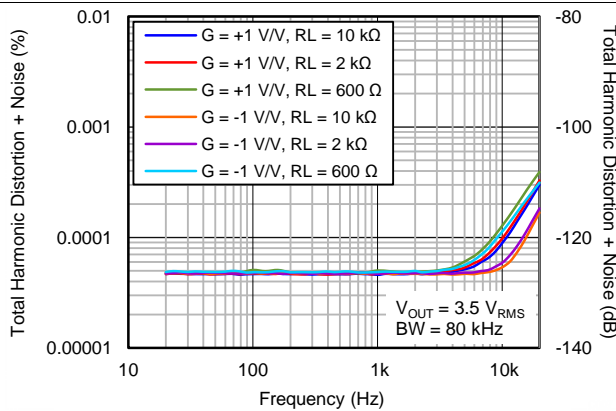

Figure 15. THD+N Ratio vs Frequency

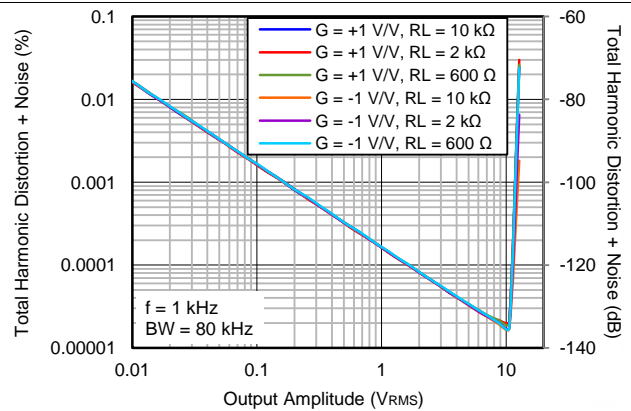

Figure 16. THD+N vs Output Amplitude

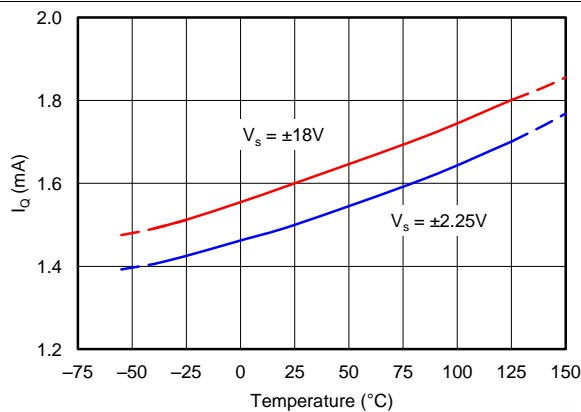

Figure 17. Quiescent Current vs Temperature

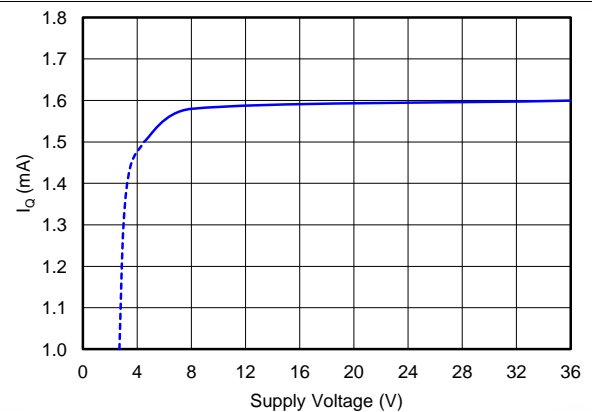

Figure 18. Quiescent Current vs Supply Voltage

Typical Characteristics (continued)

at $V_S = \pm 18\text{ V}$, $V_{CM} = V_S / 2$, $R_{LOAD} = 10\text{ k}\Omega$ connected to $V_S / 2$, and $C_L = 100\text{ pF}$ (unless otherwise noted)

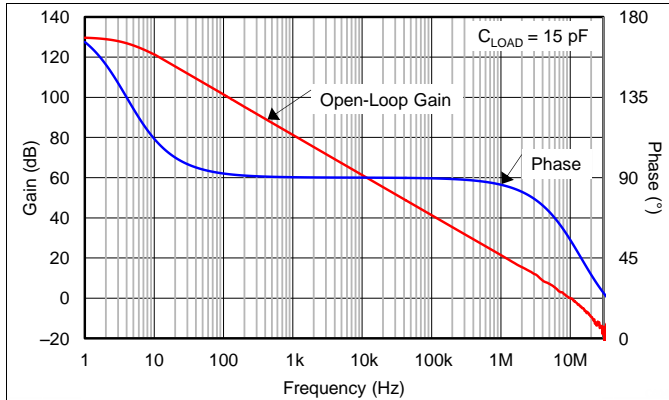

Figure 19. Open-Loop Gain and Phase vs Frequency

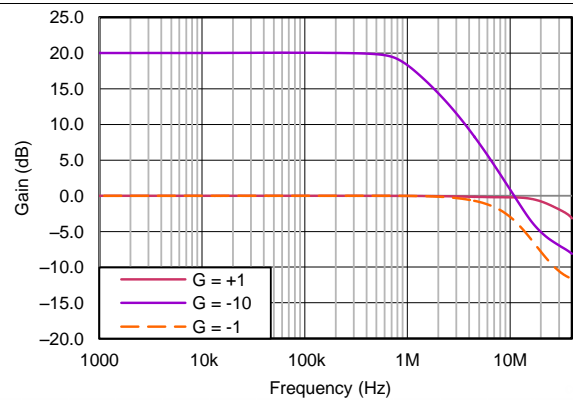

Figure 20. Closed-Loop Gain vs Frequency

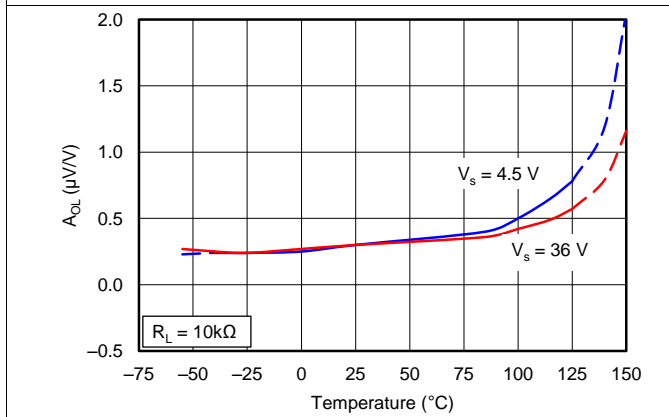

Figure 21. Open-Loop Gain vs Temperature

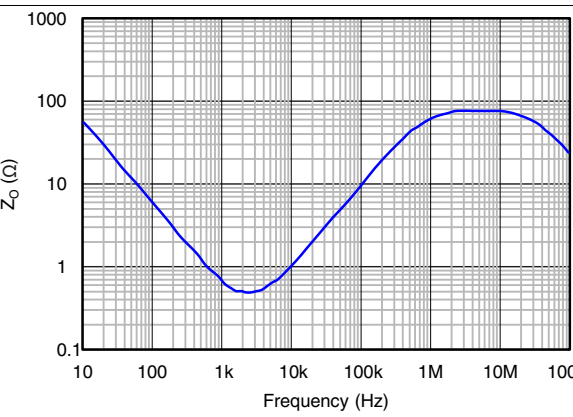

Figure 22. Open-Loop Output Impedance vs Frequency

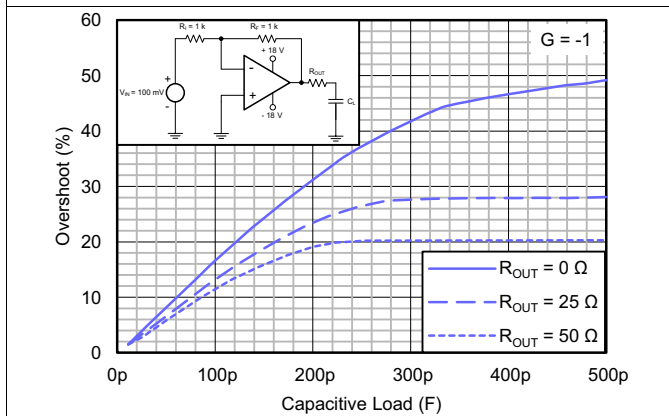

Figure 23. Small-Signal Overshoot vs Capacitive Load (100-mV Output Step)

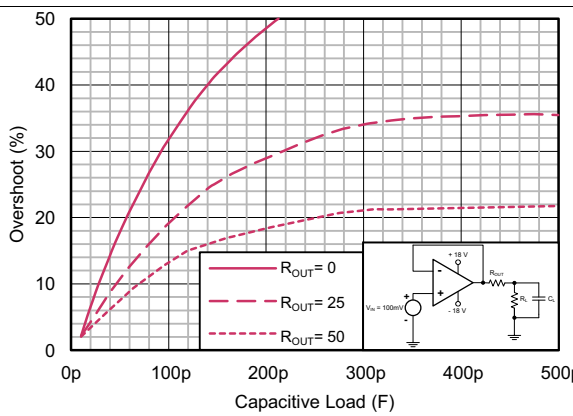

Figure 24. Small-Signal Overshoot vs Capacitive Load (100-mV Output Step)

Typical Characteristics (continued)

at $V_S = \pm 18\text{ V}$, $V_{CM} = V_S / 2$, $R_{LOAD} = 10\text{ k}\Omega$ connected to $V_S / 2$, and $C_L = 100\text{ pF}$ (unless otherwise noted)

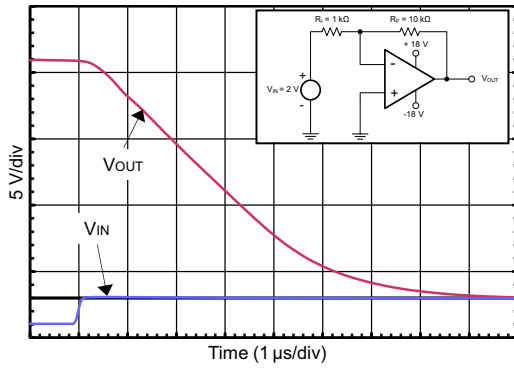

Figure 25. Positive Overload Recovery

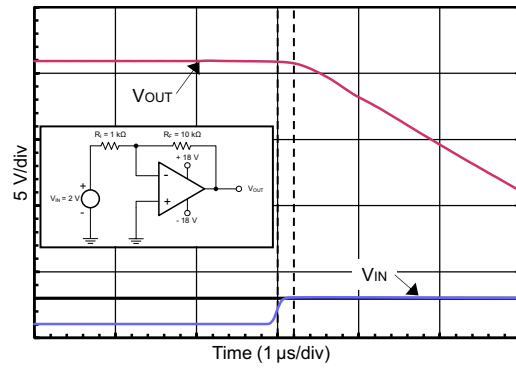

Figure 26. Positive Overload Recovery (Zoomed In)

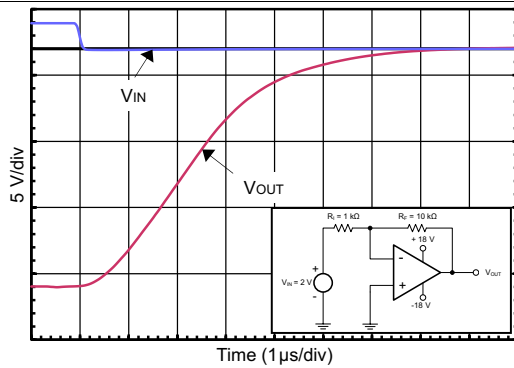

Figure 27. Negative Overload Recovery

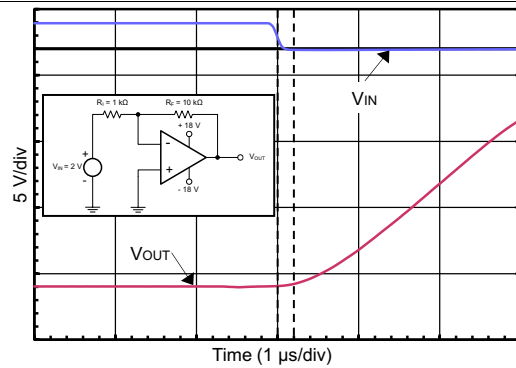

Figure 28. Negative Overload Recovery (Zoomed In)

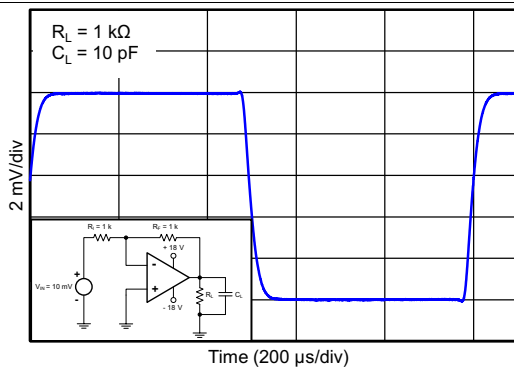

Figure 29. Small-Signal Step Response (10 mV, G = -1)

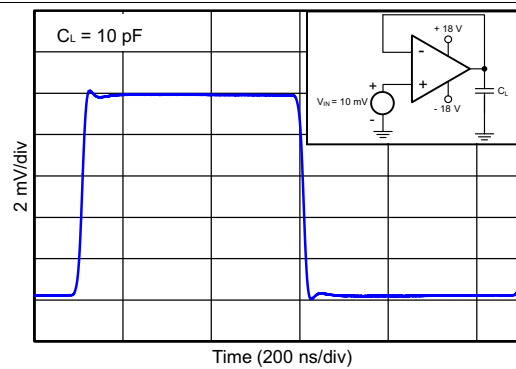
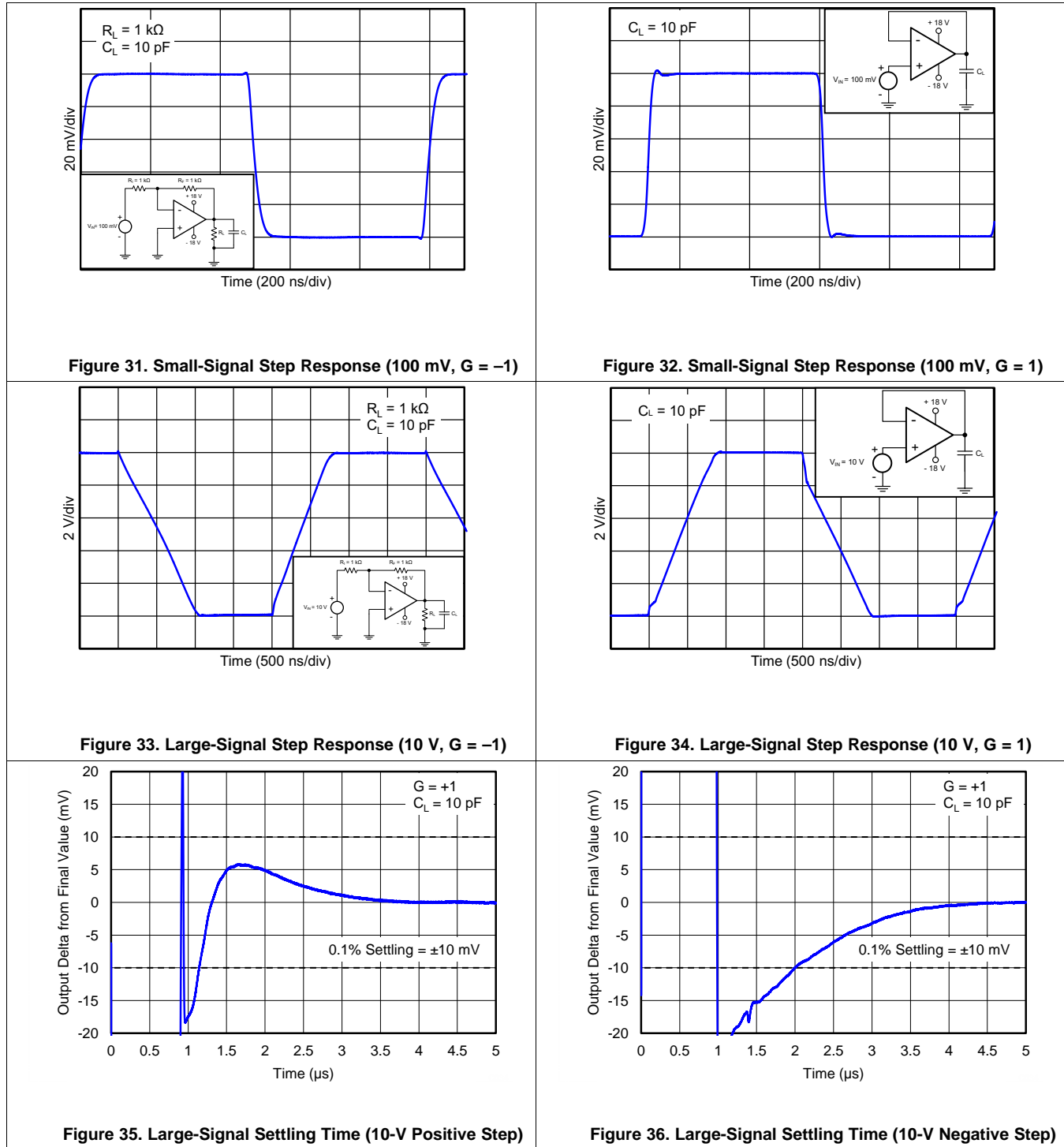

Figure 30. Small-Signal Step Response (10 mV, G = 1)

Typical Characteristics (continued)

at $V_S = \pm 18\text{ V}$, $V_{CM} = V_S / 2$, $R_{LOAD} = 10\text{ k}\Omega$ connected to $V_S / 2$, and $C_L = 100\text{ pF}$ (unless otherwise noted)



Typical Characteristics (continued)

at $V_S = \pm 18\text{ V}$, $V_{CM} = V_S / 2$, $R_{LOAD} = 10\text{ k}\Omega$ connected to $V_S / 2$, and $C_L = 100\text{ pF}$ (unless otherwise noted)

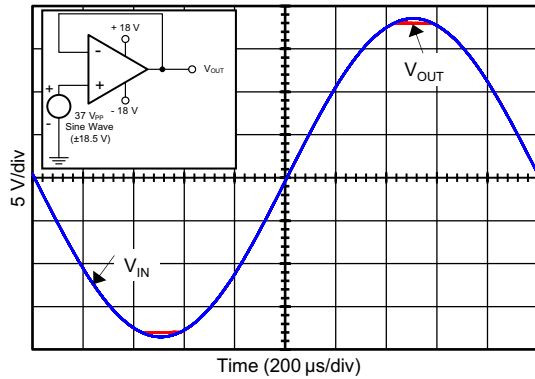

Figure 37. No Phase Reversal

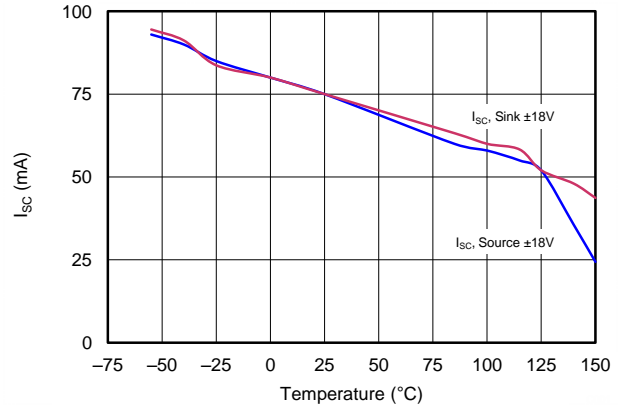

Figure 38. Short-Circuit Current vs Temperature

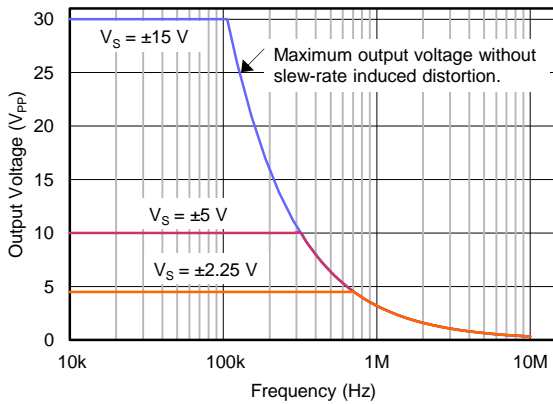

Figure 39. Maximum Output Voltage vs Frequency

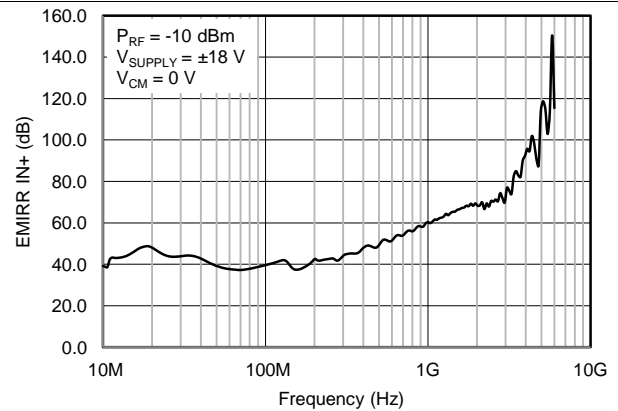

Figure 40. EMIRR vs Frequency

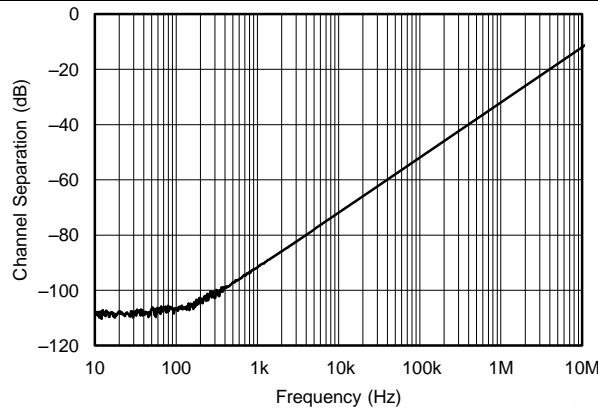

Figure 41. Channel Separation vs Frequency

8 Detailed Description

8.1 Overview

The OPAx172-Q1 family of operational amplifiers provide high overall performance, making the devices ideal for many general-purpose applications. The excellent offset drift of only $1.5 \mu\text{V}/^\circ\text{C}$ (maximum) provides excellent stability over the entire temperature range. In addition, the family offers very good overall performance with high CMRR, PSRR, A_{OL} , and superior THD.

The [Functional Block Diagram](#) section shows the simplified diagram of the OPA172-Q1 design. The design topology is a highly-optimized, three-stage amplifier with an active-feedforward gain stage.

8.2 Functional Block Diagram

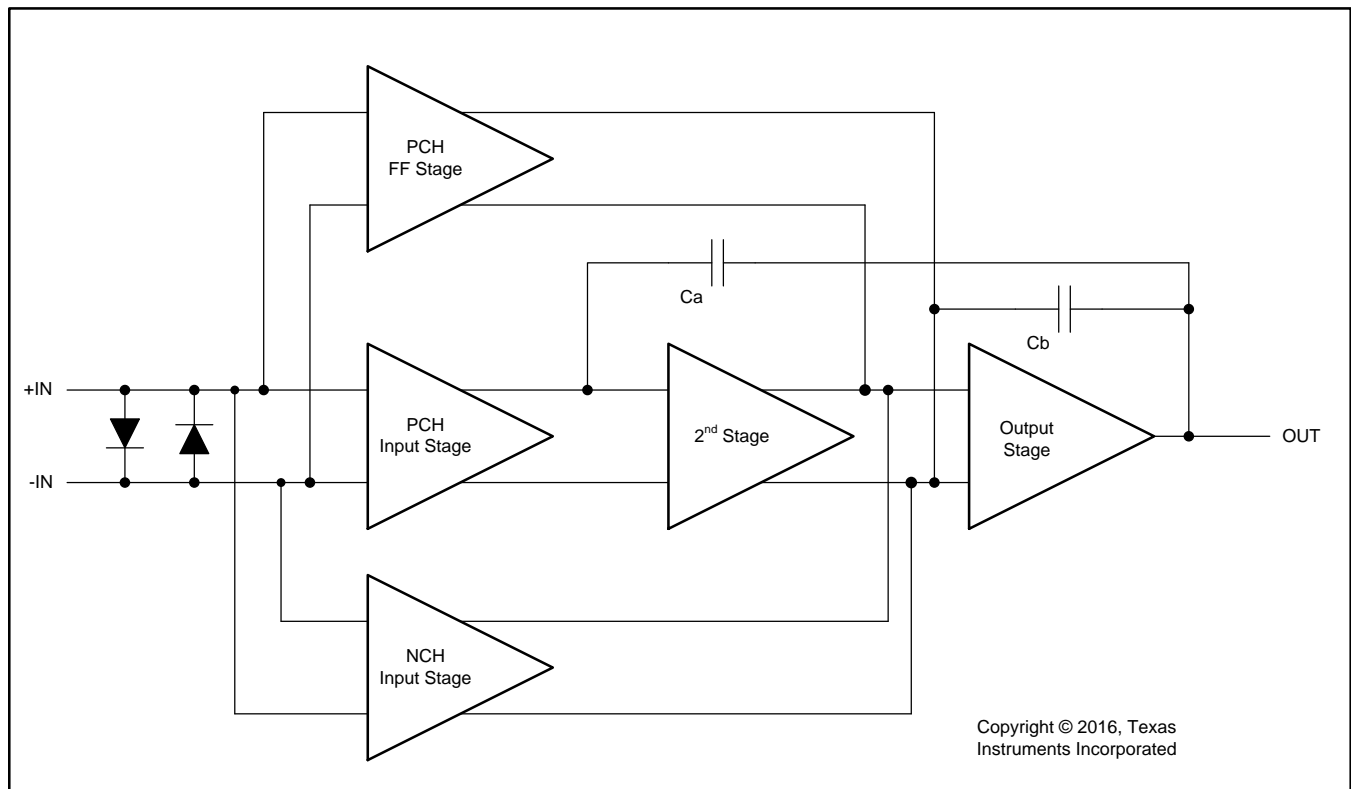

8.3 Feature Description

8.3.1 EMI Rejection

The OPAx172-Q1 uses integrated electromagnetic interference (EMI) filtering to reduce the effects of EMI from sources such as wireless communications and densely-populated boards with a mix of analog signal chain and digital components. EMI immunity can be improved with circuit design techniques; the OPAx172-Q1 benefits from these design improvements. Texas Instruments has developed the ability to accurately measure and quantify the immunity of an operational amplifier over a broad frequency spectrum extending from 10 MHz to 6 GHz. Figure 42 shows the results of this testing on the OPAx172-Q1. Table 3 shows the EMIRR IN+ values for the OPAx172-Q1 at particular frequencies commonly encountered in real-world applications. Applications listed in Table 3 can be centered on or operated near the particular frequency shown. Detailed information can also be found in the [EMI Rejection Ratio of Operational Amplifiers application report](#) (SBOA128), available for download from www.ti.com.

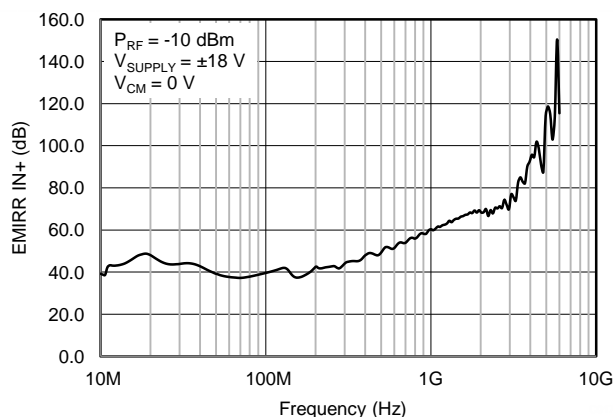

Figure 42. EMIRR Testing

Table 3. OPAx172-Q1 EMIRR IN+ for Frequencies of Interest

FREQUENCY	APPLICATION OR ALLOCATION	EMIRR IN+
400 MHz	Mobile radio, mobile satellite, space operation, weather, radar, ultrahigh frequency (UHF) applications	47.6 dB
900 MHz	Global system for mobile communications (GSM) applications, radio communication, navigation, GPS (to 1.6 GHz), GSM, aeronautical mobile, UHF applications	58.5 dB
1.8 GHz	GSM applications, mobile personal communications, broadband, satellite, L-band (1 GHz to 2 GHz)	68 dB
2.4 GHz	802.11b, 802.11g, 802.11n, Bluetooth®, mobile personal communications, industrial, scientific and medical (ISM) radio band, amateur radio and satellite, S-band (2 GHz to 4 GHz)	69.2 dB
3.6 GHz	Radiolocation, aero communication and navigation, satellite, mobile, S-band	82.9 dB
5 GHz	802.11a, 802.11n, aero communication and navigation, mobile communication, space and satellite operation, C-band (4 GHz to 8 GHz)	114 dB

8.3.2 Phase-Reversal Protection

The OPAx172-Q1 family has internal phase-reversal protection. Many op amps exhibit a phase reversal when the input is driven beyond the linear common-mode range. This condition is most often encountered in noninverting circuits when the input is driven beyond the specified common-mode voltage range, causing the output to reverse into the opposite rail. The input of the OPAx172-Q1 prevents phase reversal with excessive common-mode voltage. Instead, the appropriate rail limits the output voltage. This performance is shown in Figure 43.

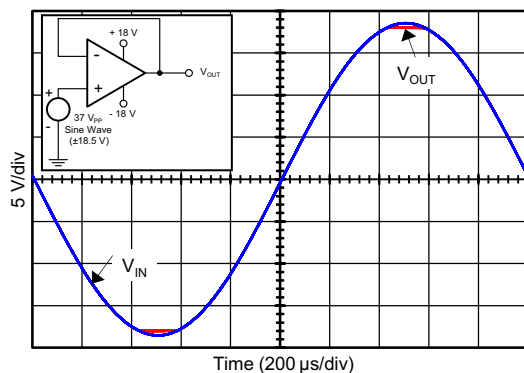

Figure 43. No Phase Reversal

8.3.3 Capacitive Load and Stability

The dynamic characteristics of the OPAx172-Q1 are optimized for commonly-used operating conditions. The combination of low closed-loop gain and high capacitive loads decreases the phase margin of the amplifier and can lead to gain peaking or oscillations. As a result, heavier capacitive loads must be isolated from the output. The simplest way to achieve this isolation is to add a small resistor (for example, $R_{OUT} = 50 \Omega$) in series with the output. Figure 44 and Figure 45 show graphs of small-signal overshoot versus capacitive load for several values of R_{OUT} . See the *Feedback Plots Define Op Amp AC Performance* application bulletin (SBOA015), available for download from www.ti.com, for details of analysis techniques and application circuits.

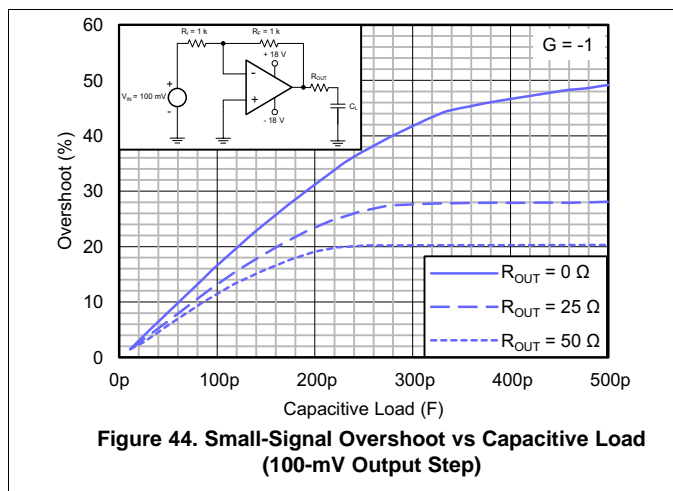

Figure 44. Small-Signal Overshoot vs Capacitive Load (100-mV Output Step)

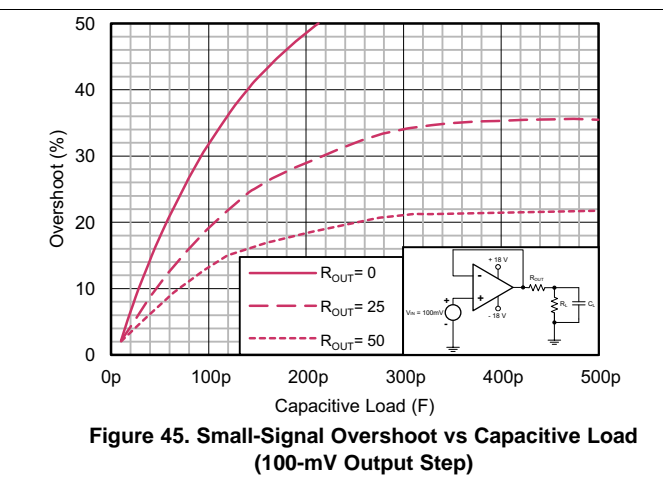

Figure 45. Small-Signal Overshoot vs Capacitive Load (100-mV Output Step)

8.4 Device Functional Modes

8.4.1 Common-Mode Voltage Range

The input common-mode voltage range of the OPAx172-Q1 series extends 100 mV below the negative rail and within 2 V of the top rail for normal operation.

This device can operate with a full rail-to-rail input 100 mV beyond the top rail, but with reduced performance within 2 V of the top rail. The typical performance in this range is summarized in [Table 4](#).

Table 4. Typical Performance Range ($V_S = \pm 18\text{ V}$)

	MIN	TYP	MAX	UNIT
Input common-mode voltage	$(V+) - 2$		$(V+) + 0.1$	V
Offset voltage		5		mV
Offset voltage vs temperature ($T_A = -40^\circ\text{C}$ to $+125^\circ\text{C}$)		10		$\mu\text{V}/^\circ\text{C}$
Common-mode rejection		70		dB
Open-loop gain		60		dB
Gain bandwidth product (GBP)		4		MHz
Slew rate		4		$\text{V}/\mu\text{s}$
Noise at $f = 1\text{ kHz}$		22		$\text{nV}/\sqrt{\text{Hz}}$

8.4.2 Electrical Overstress

Designers often ask questions about the capability of an operational amplifier to withstand electrical overstress. These questions tend to focus on the device inputs, but can involve the supply voltage terminals or even the output terminal. Each of these different terminal functions have electrical stress limits determined by the voltage breakdown characteristics of the particular semiconductor fabrication process and specific circuits connected to the terminal. Additionally, internal electrostatic discharge (ESD) protection is built into these circuits for protection from accidental ESD events both before and during product assembly.

A good understanding of this basic ESD circuitry and the relevance to an electrical overstress event is helpful. [Figure 46](#) illustrates the ESD circuits contained in the OPAx172-Q1 (indicated by the dashed line area). The ESD protection circuitry involves several current-steering diodes connected from the input and output terminals and routed back to the internal power-supply lines, where the diodes meet at an absorption device internal to the operational amplifier. This protection circuitry is intended to remain inactive during normal circuit operation.

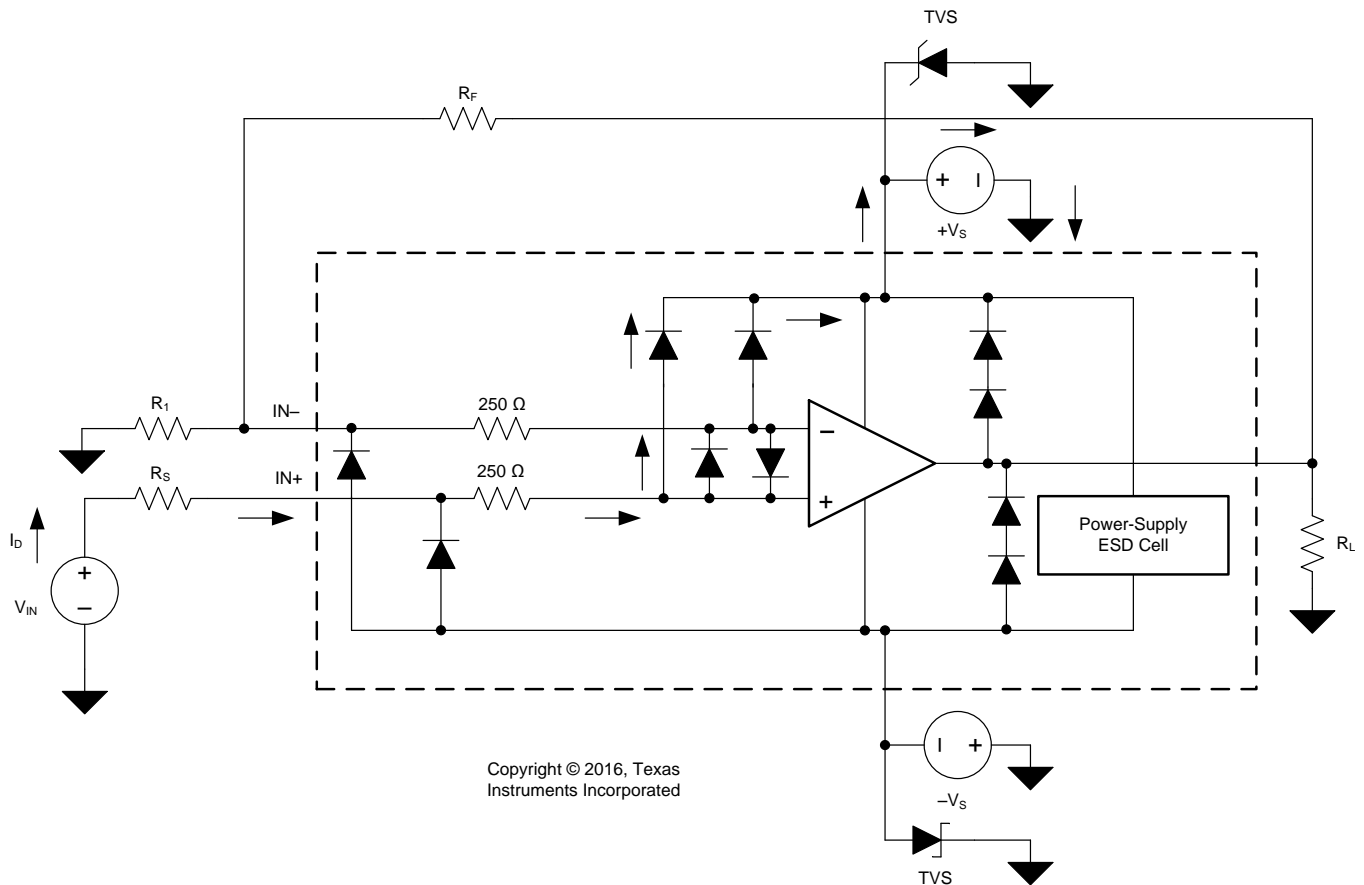

Figure 46. Equivalent Internal ESD Circuitry Relative to a Typical Circuit Application

An ESD event produces a short-duration, high-voltage pulse that is transformed into a short-duration, high-current pulse when discharging through a semiconductor device. The ESD protection circuits are designed to provide a current path around the operational amplifier core to prevent damage. The energy absorbed by the protection circuitry is then dissipated as heat.

When an ESD voltage develops across two or more amplifier device terminals, current flows through one or more steering diodes. Depending on the path that the current takes, the absorption device can activate. The absorption device has a trigger, or threshold voltage, that is above the normal operating voltage of the OPAx172-Q1 but below the device breakdown voltage level. When this threshold is exceeded, the absorption device quickly activates and clamps the voltage across the supply rails to a safe level.

When the operational amplifier connects into a circuit (as shown in Figure 46), the ESD protection components are intended to remain inactive and do not become involved in the application circuit operation. However, circumstances can arise where an applied voltage exceeds the operating voltage range of a given terminal. If this condition occurs, there is a risk that some internal ESD protection circuits can turn on and conduct current. Any such current flow occurs through steering-diode paths and rarely involves the absorption device.

Figure 46 shows a specific example where the input voltage (V_{IN}) exceeds the positive supply voltage ($+V_S$) by 500 mV or more. Much of what happens in the circuit depends on the supply characteristics. If $+V_S$ can sink the current, one of the upper input steering diodes conducts and directs current to $+V_S$. Excessively high current levels can flow with increasingly higher V_{IN} . As a result, the data sheet specifications recommend that applications limit the input current to 10 mA.

If the supply is not capable of sinking the current, V_{IN} can begin sourcing current to the operational amplifier, and then take over as the source of positive supply voltage. The danger in this case is that the voltage can rise to levels that exceed the operational amplifier absolute maximum ratings.

Another common question involves what happens to the amplifier if an input signal is applied to the input when the power supplies $+V_S$ or $-V_S$ are at 0 V. Again, this question depends on the supply characteristic when at 0 V, or at a level below the input-signal amplitude. If the supplies appear as high impedance, then the input source supplies the operational amplifier current through the current-steering diodes. This state is not a normal bias condition; most likely, the amplifier does not operate normally. If the supplies are low impedance, then the current through the steering diodes can become quite high. The current level depends on the ability of the input source to deliver current, and any resistance in the input path.

If there is any uncertainty about the ability of the supply to absorb this current, add external zener diodes to the supply terminals; see [Figure 46](#). Select the zener voltage so that the diode does not turn on during normal operation. However, the zener voltage must be low enough so that the zener diode conducts if the supply terminal begins to rise above the safe-operating, supply-voltage level.

The OPAx172-Q1 input terminals are protected from excessive differential voltage with back-to-back diodes; see [Figure 46](#). In most circuit applications, the input protection circuitry has no effect. However, in low-gain or $G = 1$ circuits, fast-ramping input signals can forward-bias these diodes because the output of the amplifier cannot respond rapidly enough to the input ramp. If the input signal is fast enough to create this forward-bias condition, limit the input signal current to 10 mA or less. If the input signal current is not inherently limited, an input series resistor can be used to limit the input signal current. This input series resistor degrades the low-noise performance of the OPAx172-Q1. [Figure 46](#) illustrates an example configuration that implements a current-limiting feedback resistor.

8.4.3 Overload Recovery

Overload recovery is defined as the time required for the op amp output to recover from the saturated state to the linear state. The output devices of the op amp enter the saturation region when the output voltage exceeds the rated operating voltage, either resulting from the high input voltage or the high gain. After the device enters the saturation region, the charge carriers in the output devices need time to return back to the normal state. After the charge carriers return back to the equilibrium state, the device begins to slew at the normal slew rate. Thus, the propagation delay in case of an overload condition is the sum of the overload recovery time and the slew time. The overload recovery time for the OPAx172-Q1 is approximately 200 ns.

9 Applications and Implementation

NOTE

Information in the following applications sections is not part of the TI component specification, and TI does not warrant its accuracy or completeness. TI's customers are responsible for determining suitability of components for their purposes. Customers should validate and test their design implementation to confirm system functionality.

9.1 Application Information

The OPAx172-Q1 family of amplifiers is specified for operation from 4.5 V to 36 V (± 2.25 V to ± 18 V). Many of the specifications apply from -40°C to $+125^{\circ}\text{C}$. Parameters that can exhibit significant variance with regard to operating voltage or temperature are presented in the [Typical Characteristics](#) section.

9.2 Typical Applications

The following application examples highlight only a few of the circuits where the OPAx172-Q1 can be used.

9.2.1 Capacitive Load Drive Solution Using an Isolation Resistor

The OPA172-Q1 can be used capacitive loads such as cable shields, reference buffers, MOSFET gates, and diodes. The circuit uses an isolation resistor (R_{ISO}) to stabilize the output of an op amp. R_{ISO} modifies the open-loop gain of the system to ensure the circuit has sufficient phase margin, as shown in [Figure 47](#).

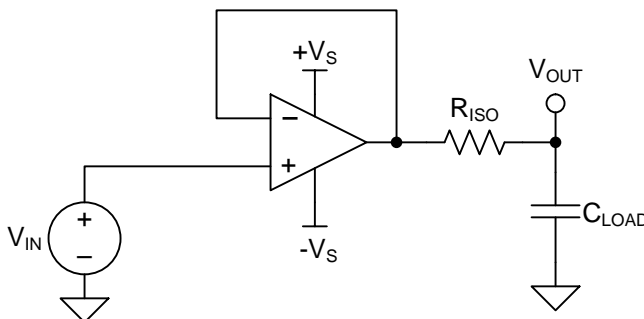

Figure 47. Unity-Gain Buffer with R_{ISO} Stability Compensation

9.2.1.1 Design Requirements

The design requirements are:

- Supply voltage: 30 V (± 15 V)
- Capacitive loads: 100 pF, 1000 pF, 0.01 μF , 0.1 μF , and 1 μF
- Phase margin: 45° and 60°

Typical Applications (continued)

9.2.1.2 Detailed Design Procedure

Figure 47 depicts a unity-gain buffer driving a capacitive load. Equation 1 shows the transfer function for the circuit in Figure 47. Not depicted in Figure 47 is the open-loop output resistance of the op amp, R_o .

$$T(s) = \frac{1 + C_{LOAD} \times R_{ISO} \times s}{1 + (R_o + R_{ISO}) \times C_{LOAD} \times s} \quad (1)$$

The transfer function in Equation 1 has a pole and a zero. The frequency of the pole (f_p) is determined by $(R_o + R_{ISO})$ and C_{LOAD} . Components R_{ISO} and C_{LOAD} determine the frequency of the zero (f_z). A stable system is obtained by selecting R_{ISO} such that the rate of closure (ROC) between the open-loop gain (A_{OL}) and $1 / \beta$ is 20 dB per decade. Figure 48 shows the concept. Note that the $1 / \beta$ curve for a unity-gain buffer is 0 dB.

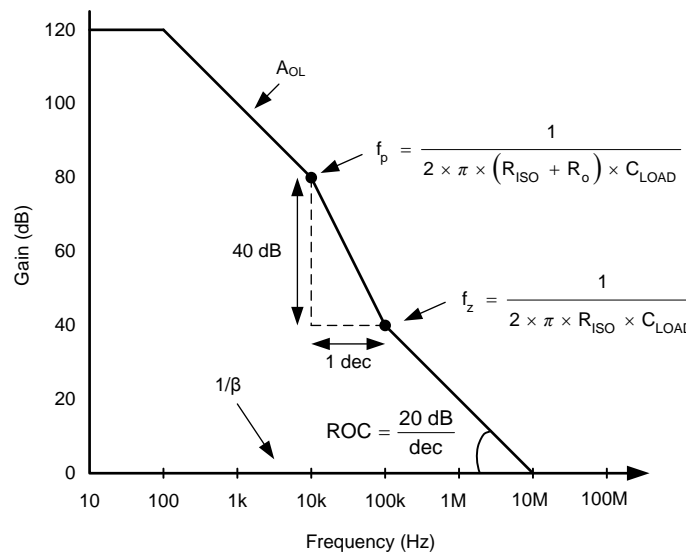

Figure 48. Unity-Gain Amplifier with R_{ISO} Compensation

ROC stability analysis is typically simulated. The validity of the analysis depends on multiple factors, especially the accurate modeling of R_o . In addition to simulating the ROC, a robust stability analysis includes a measurement of overshoot percentage and ac gain peaking of the circuit using a function generator, oscilloscope, and gain and phase analyzer. Phase margin is then calculated from these measurements. Table 5 shows the overshoot percentage and ac gain peaking that correspond to phase margins of 45° and 60°. For more details on this design and other alternative devices that can be used in place of the OPA172-Q1, see the [Capacitive Load Drive Solution using an Isolation Resistor precision design](#) (TIPD128).

Table 5. Phase Margin versus Overshoot and AC Gain Peaking

PHASE MARGIN	OVERSHOOT	AC GAIN PEAKING
45°	23.3%	2.35 dB
60°	8.8%	0.28 dB

9.2.1.3 Application Curve

The OPA172-Q1 meets the supply voltage requirements of 30 V. The OPA172-Q1 is tested for various capacitive loads and R_{ISO} is adjusted to get an overshoot corresponding to Table 5. The results of these tests are summarized in Figure 49.

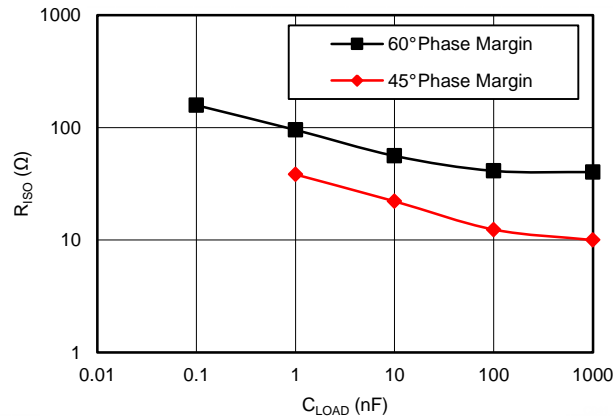

Figure 49. R_{ISO} vs C_{LOAD}

9.2.2 Bidirectional Current Source

The improved Howland current-pump topology shown in Figure 50 provides excellent performance because of the extremely tight tolerances of the on-chip resistors of the INA132. By buffering the output using an OPA172-Q1, the output current the circuit is able to deliver is greatly extended.

The circuit dc transfer function is shown in Equation 2.

$$I_{OUT} = V_{IN} / R1 \tag{2}$$

The OPA172-Q1 can also be used as the feedback amplifier because the low bias current minimizes error voltages produced across R1. However, for improved performance, select a FET-input device with extremely low offset, such as the OPA192, OPA140, or OPA188 as the feedback amplifier.

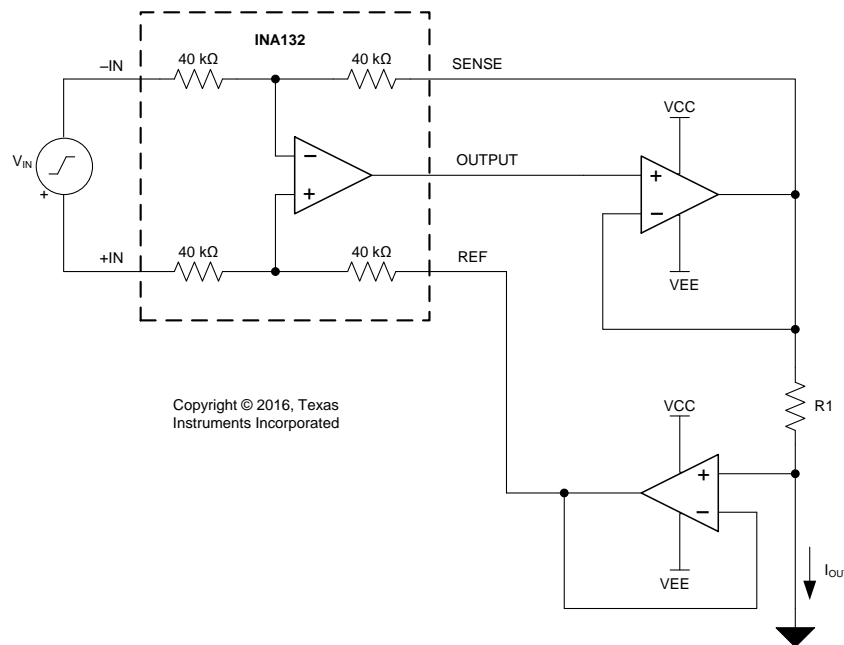

Figure 50. Bidirectional Current Source

9.2.3 JFET-Input Low-Noise Amplifier

Figure 51 shows a low-noise composite amplifier built by adding a low noise JFET pair (Q1 and Q2) as an input preamplifier for the OPA172-Q1. Transistors Q3 and Q4 form a 2-mA current sink that biases each JFET with 1 mA of drain current. Using 3.9-kΩ drain resistors produces a gain of approximately 10 in the input amplifier, making the extremely-low, broadband-noise spectral density of the JFET pair, Q1 and Q2, the dominant noise source of the amplifier. The output impedance of the input differential amplifier is large enough that a FET-input amplifier such as the OPA172-Q1 provides superior noise performance over bipolar-input amplifiers.

The gain of the composite amplifier is given by Equation 3.

$$A_v = (1 + R_3 / R_4) \tag{3}$$

The resistances shown are standard 1% resistor values that produce a gain of approximately 100 (99.26) with 68° of phase margin. Gains less than 10 may require additional compensation methods to provide stability. Select low resistor values to minimize the resistor thermal noise contribution to the total output noise.

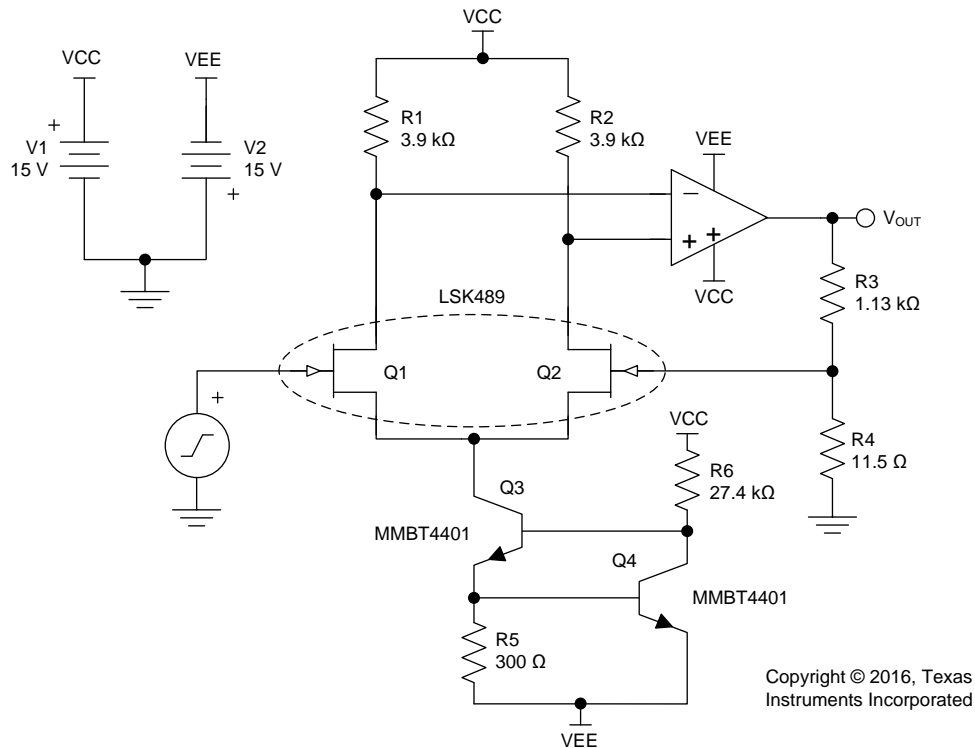

Copyright © 2016, Texas Instruments Incorporated

Figure 51. JFET-Input Low-Noise Amplifier

10 Power Supply Recommendations

The OPA172-Q1 is specified for operation from 4.5 V to 36 V (± 2.25 V to ± 18 V); many specifications apply from -40°C to $+125^{\circ}\text{C}$. Parameters that can exhibit significant variance with regard to operating voltage or temperature are presented in the [Typical Characteristics](#) section.

CAUTION

Supply voltages larger than 40 V can permanently damage the device; see the [Absolute Maximum Ratings](#) table.

Place 0.1- μF bypass capacitors close to the power-supply terminals to reduce errors coupling in from noisy or high-impedance power supplies. For more detailed information on bypass capacitor placement, see the [Layout](#) section.

11 Layout

11.1 Layout Guidelines

For best operational performance of the device, use good printed circuit board (PCB) layout practices, including:

- Noise can propagate into analog circuitry through the power pins of the circuit as a whole and of op amp itself. Bypass capacitors are used to reduce the coupled noise by providing low-impedance power sources local to the analog circuitry.
 - Connect low-ESR, 0.1- μF ceramic bypass capacitors between each supply pin and ground, placed as close to the device as possible. A single bypass capacitor from V+ to ground is applicable for single-supply applications.
- Separate grounding for analog and digital portions of circuitry is one of the simplest and most-effective methods of noise suppression. One or more layers on multilayer PCBs are usually devoted to ground planes. A ground plane helps distribute heat and reduces EMI noise pickup. Make sure to physically separate digital and analog grounds paying attention to the flow of the ground current.
- In order to reduce parasitic coupling, run the input traces as far away from the supply or output traces as possible. If these traces cannot be kept separate, crossing the sensitive trace perpendicular as opposed to in parallel with the noisy trace is preferable.
- Place the external components as close to the device as possible. As illustrated in [Figure 52](#), keeping RF and RG close to the inverting input minimizes parasitic capacitance.
- Keep the length of input traces as short as possible. Always remember that the input traces are the most sensitive part of the circuit.
- Consider a driven, low-impedance guard ring around the critical traces. A guard ring can significantly reduce leakage currents from nearby traces that are at different potentials.

11.2 Layout Example

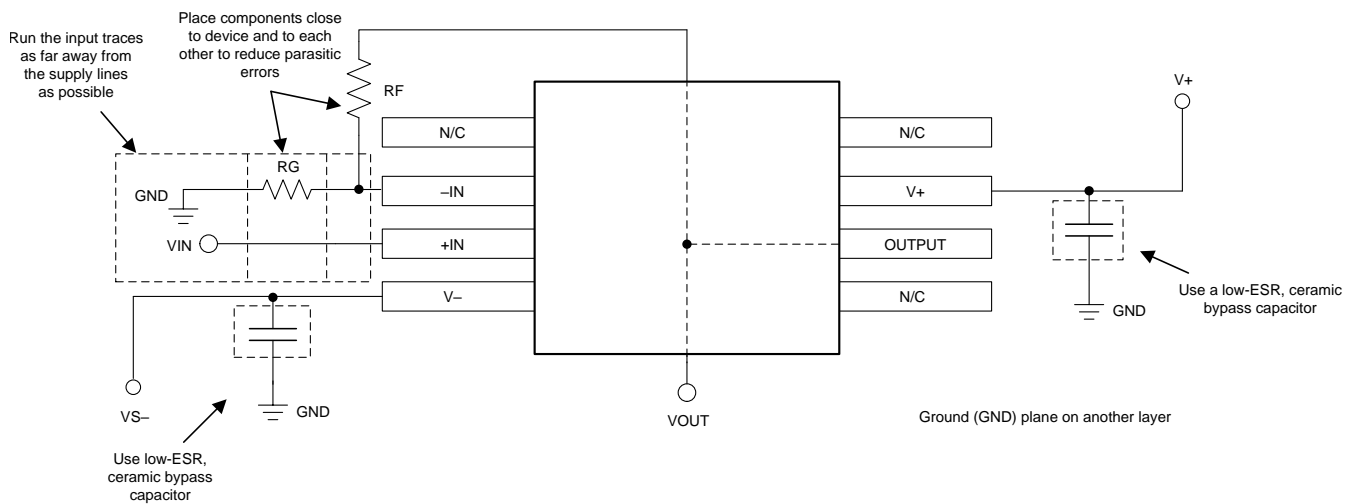

Copyright © 2017, Texas Instruments Incorporated

Figure 52. Operational Amplifier Board Layout for a Noninverting Configuration

12 デバイスおよびドキュメントのサポート

12.1 デバイス・サポート

12.1.1 開発サポート

12.1.1.1 TINA-TI™(無料のダウンロード・ソフトウェア)

TINA-TI™は、SPICEエンジンをベースにした単純かつ強力な、使いやすい回路シミュレーション・プログラムです。TINA-TI™はTINA-TI™ソフトウェアの無料バージョンで、完全な機能を持ち、パッシブとアクティブ両方のモデルに加えて、マクロ・モデルのライブラリがプリロードされています。TINA-TI™には従来型のDC、過渡、および周波数ドメインのSPICEによる分析と、追加の設計機能が搭載されています。

TINA-TI™はAnalog eLab Design Centerから無料でダウンロードでき、ユーザーが結果をさまざまな方法でフォーマットできる、広範な後処理機能を備えています。仮想計測器により、入力波形を選択し、回路ノード、電圧、および波形をプローブして、動的なクイック・スタート・ツールを作成できます。

注

これらのファイルを使用するには、TINA ソフトウェア (DesignSoft™製) またはTINA-TI™ソフトウェアがインストールされている必要があります。TINA-TI™フォルダから、無料のTINA-TI™ソフトウェアをダウンロードしてください。

12.2 ドキュメントのサポート

12.2.1 関連資料

関連資料については、以下を参照してください:

- 『フィードバック・プロットによるオペアンプAC性能の定義』(SBOA015)
- 『オペアンプのEMI除去率』(SBOA128)
- 『絶縁抵抗の使用による容量性負荷駆動のソリューション』(TIPD032)
- 『INA132 低消費電力、単一電源の差動アンプ』(SBOS059)
- 『OPAx192 36V、高精度、レール・ツー・レール入力/出力、低オフセット電圧、e-trim™低入力バイアス電流オペアンプ』(SBOS620)
- 『OPA140 高精度、低ノイズ、レール・ツー・レール出力、11MHz JFETオペアンプ』(SBOS498)
- 『OPA188 高精度、低ノイズ、レール・ツー・レール出力、36V、ゼロドリフトのオペアンプ』(SBOS642)

12.3 関連リンク

次の表に、クイック・アクセス・リンクを示します。カテゴリには、技術資料、サポートおよびコミュニティ・リソース、ツールとソフトウェア、およびご注文へのクイック・アクセスが含まれます。

表 6. 関連リンク

製品	プロダクト・フォルダ	ご注文はこちら	技術資料	ツールとソフトウェア	サポートとコミュニティ
OPA2172-Q1	ここをクリック	ここをクリック	ここをクリック	ここをクリック	ここをクリック
OPA4172-Q1	ここをクリック	ここをクリック	ここをクリック	ここをクリック	ここをクリック

12.4 ドキュメントの更新通知を受け取る方法

ドキュメントの更新についての通知を受け取るには、ti.comのデバイス製品フォルダを開いてください。右上の隅にある「通知を受け取る」をクリックして登録すると、変更されたすべての製品情報に関するダイジェストを毎週受け取れます。変更の詳細については、修正されたドキュメントに含まれている改訂履歴をご覧ください。

12.5 コミュニティ・リソース

The following links connect to TI community resources. Linked contents are provided "AS IS" by the respective contributors. They do not constitute TI specifications and do not necessarily reflect TI's views; see TI's [Terms of Use](#).

TI E2E™オンライン・コミュニティ *TIのE2E (Engineer-to-Engineer)* コミュニティ。エンジニア間の共同作業を促進するために開設されたものです。e2e.ti.comでは、他のエンジニアに質問し、知識を共有し、アイデアを検討して、問題解決に役立てることができます。

設計サポート *TIの設計サポート* 役に立つE2Eフォーラムや、設計サポート・ツールをすばやく見つけることができます。技術サポート用の連絡先情報も参照できます。

12.6 商標

TINA-TI, E2E are trademarks of Texas Instruments.
 Bluetooth is a registered trademark of Bluetooth SIG, Inc.
 DesignSoft is a trademark of DesignSoft, Inc.
 All other trademarks are the property of their respective owners.

12.7 静電気放電に関する注意事項



すべての集積回路は、適切なESD保護方法を用いて、取扱いと保存を行うようにして下さい。

静電気放電はわずかな性能の低下から完全なデバイスの故障に至るまで、様々な損傷を与えます。高精度の集積回路は、損傷に対して敏感であり、極めてわずかなパラメータの変化により、デバイスに規定された仕様に適合しなくなる場合があります。

12.8 Glossary

SLYZ022 — *TI Glossary*.

This glossary lists and explains terms, acronyms, and definitions.

13 メカニカル、パッケージ、および注文情報

以降のページには、メカニカル、パッケージ、および注文に関する情報が記載されています。この情報は、そのデバイスについて利用可能な最新のデータです。このデータは予告なく変更されることがあり、ドキュメントが改訂される場合もあります。本データシートのブラウザ版を使用されている場合は、画面左側の説明をご覧ください。

PACKAGING INFORMATION

Orderable part number	Status (1)	Material type (2)	Package Pins	Package qty Carrier	RoHS (3)	Lead finish/ Ball material (4)	MSL rating/ Peak reflow (5)	Op temp (°C)	Part marking (6)
OPA2172QDGKQ1	Active	Production	VSSOP (DGK) 8	80 TUBE	Yes	NIPDAUAG	Level-2-260C-1 YEAR	-40 to 125	18W6
OPA2172QDGKQ1.B	Active	Production	VSSOP (DGK) 8	80 TUBE	Yes	NIPDAUAG	Level-2-260C-1 YEAR	-40 to 125	18W6
OPA2172QDGKRQ1	Active	Production	VSSOP (DGK) 8	2500 LARGE T&R	Yes	NIPDAU NIPDAUAG	Level-2-260C-1 YEAR	-40 to 125	18W6
OPA2172QDGKRQ1.B	Active	Production	VSSOP (DGK) 8	2500 LARGE T&R	Yes	NIPDAUAG	Level-2-260C-1 YEAR	-40 to 125	18W6
OPA4172AQPWRQ1	Active	Production	TSSOP (PW) 14	2000 LARGE T&R	Yes	NIPDAU	Level-2-260C-1 YEAR	-40 to 125	4172Q1
OPA4172AQPWRQ1.B	Active	Production	TSSOP (PW) 14	2000 LARGE T&R	Yes	NIPDAU	Level-2-260C-1 YEAR	-40 to 125	4172Q1

(1) **Status:** For more details on status, see our [product life cycle](#).

(2) **Material type:** When designated, preproduction parts are prototypes/experimental devices, and are not yet approved or released for full production. Testing and final process, including without limitation quality assurance, reliability performance testing, and/or process qualification, may not yet be complete, and this item is subject to further changes or possible discontinuation. If available for ordering, purchases will be subject to an additional waiver at checkout, and are intended for early internal evaluation purposes only. These items are sold without warranties of any kind.

(3) **RoHS values:** Yes, No, RoHS Exempt. See the [TI RoHS Statement](#) for additional information and value definition.

(4) **Lead finish/Ball material:** Parts may have multiple material finish options. Finish options are separated by a vertical ruled line. Lead finish/Ball material values may wrap to two lines if the finish value exceeds the maximum column width.

(5) **MSL rating/Peak reflow:** The moisture sensitivity level ratings and peak solder (reflow) temperatures. In the event that a part has multiple moisture sensitivity ratings, only the lowest level per JEDEC standards is shown. Refer to the shipping label for the actual reflow temperature that will be used to mount the part to the printed circuit board.

(6) **Part marking:** There may be an additional marking, which relates to the logo, the lot trace code information, or the environmental category of the part.

Multiple part markings will be inside parentheses. Only one part marking contained in parentheses and separated by a "~" will appear on a part. If a line is indented then it is a continuation of the previous line and the two combined represent the entire part marking for that device.

Important Information and Disclaimer: The information provided on this page represents TI's knowledge and belief as of the date that it is provided. TI bases its knowledge and belief on information provided by third parties, and makes no representation or warranty as to the accuracy of such information. Efforts are underway to better integrate information from third parties. TI has taken and continues to take reasonable steps to provide representative and accurate information but may not have conducted destructive testing or chemical analysis on incoming materials and chemicals. TI and TI suppliers consider certain information to be proprietary, and thus CAS numbers and other limited information may not be available for release.

In no event shall TI's liability arising out of such information exceed the total purchase price of the TI part(s) at issue in this document sold by TI to Customer on an annual basis.

OTHER QUALIFIED VERSIONS OF OPA2172-Q1, OPA4172-Q1 :

- Catalog : [OPA2172](#), [OPA4172](#)

NOTE: Qualified Version Definitions:

- Catalog - TI's standard catalog product

TAPE AND REEL INFORMATION

QUADRANT ASSIGNMENTS FOR PIN 1 ORIENTATION IN TAPE

*All dimensions are nominal

Device	Package Type	Package Drawing	Pins	SPQ	Reel Diameter (mm)	Reel Width W1 (mm)	A0 (mm)	B0 (mm)	K0 (mm)	P1 (mm)	W (mm)	Pin1 Quadrant
OPA2172QDGKRQ1	VSSOP	DGK	8	2500	330.0	12.4	5.3	3.4	1.4	8.0	12.0	Q1
OPA2172QDGKRQ1	VSSOP	DGK	8	2500	330.0	12.4	5.3	3.4	1.4	8.0	12.0	Q1
OPA4172AQPWRQ1	TSSOP	PW	14	2000	330.0	12.4	6.9	5.6	1.6	8.0	12.0	Q1

TAPE AND REEL BOX DIMENSIONS



*All dimensions are nominal

Device	Package Type	Package Drawing	Pins	SPQ	Length (mm)	Width (mm)	Height (mm)
OPA2172QDGKRQ1	VSSOP	DGK	8	2500	366.0	364.0	50.0
OPA2172QDGKRQ1	VSSOP	DGK	8	2500	353.0	353.0	32.0
OPA4172AQPWRQ1	TSSOP	PW	14	2000	353.0	353.0	32.0

TUBE

*All dimensions are nominal

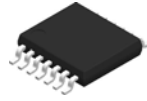
Device	Package Name	Package Type	Pins	SPQ	L (mm)	W (mm)	T (μm)	B (mm)
OPA2172QDQKQ1	DGK	VSSOP	8	80	330	6.55	500	2.88
OPA2172QDQKQ1.B	DGK	VSSOP	8	80	330	6.55	500	2.88



4220202/B 12/2023

NOTES:

1. All linear dimensions are in millimeters. Any dimensions in parenthesis are for reference only. Dimensioning and tolerancing per ASME Y14.5M.
2. This drawing is subject to change without notice.
3. This dimension does not include mold flash, protrusions, or gate burrs. Mold flash, protrusions, or gate burrs shall not exceed 0.15 mm per side.
4. This dimension does not include interlead flash. Interlead flash shall not exceed 0.25 mm per side.
5. Reference JEDEC registration MO-153.

EXAMPLE BOARD LAYOUT

PW0014A

TSSOP - 1.2 mm max height

SMALL OUTLINE PACKAGE

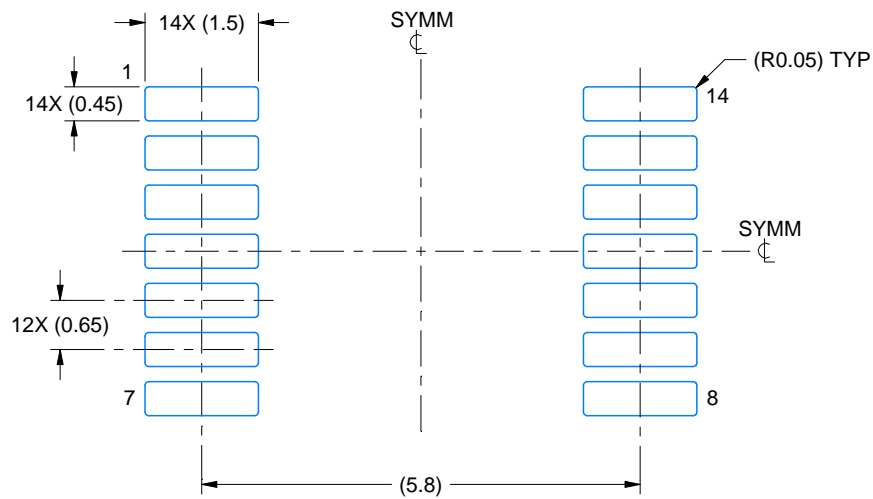

LAND PATTERN EXAMPLE
EXPOSED METAL SHOWN
SCALE: 10X

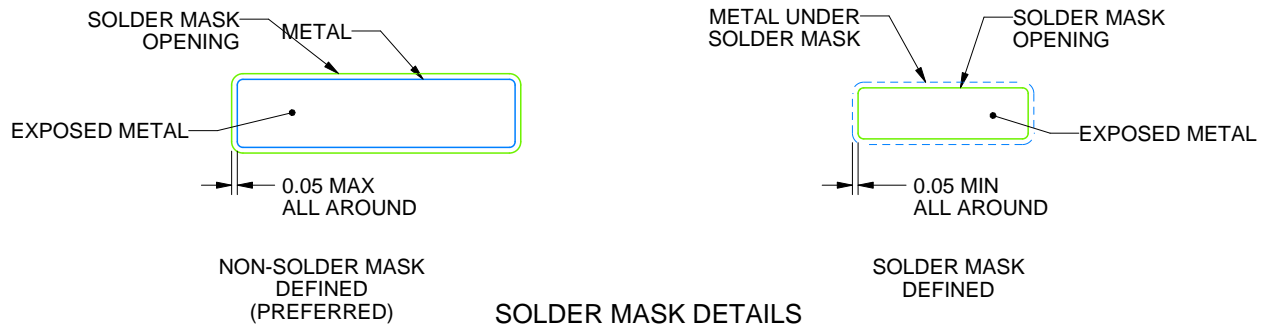

4220202/B 12/2023

NOTES: (continued)

- 6. Publication IPC-7351 may have alternate designs.
- 7. Solder mask tolerances between and around signal pads can vary based on board fabrication site.

EXAMPLE STENCIL DESIGN

PW0014A

TSSOP - 1.2 mm max height

SMALL OUTLINE PACKAGE

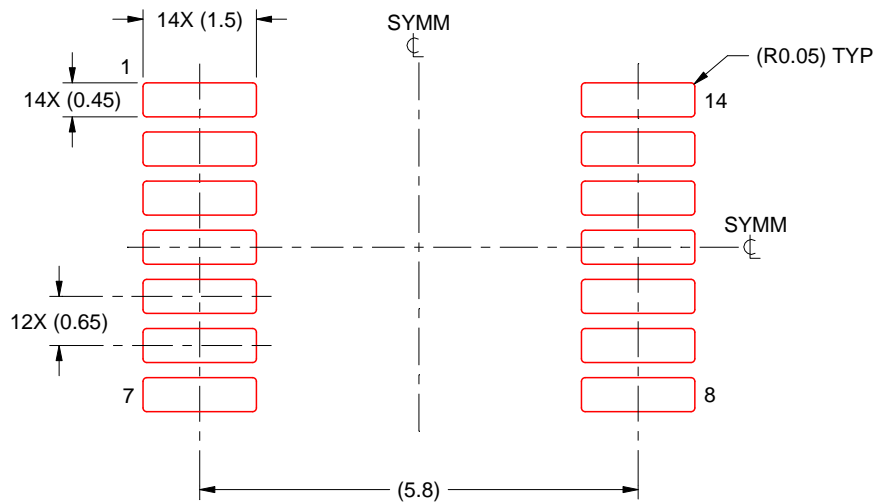

SOLDER PASTE EXAMPLE
BASED ON 0.125 mm THICK STENCIL
SCALE: 10X

4220202/B 12/2023

NOTES: (continued)

8. Laser cutting apertures with trapezoidal walls and rounded corners may offer better paste release. IPC-7525 may have alternate design recommendations.
9. Board assembly site may have different recommendations for stencil design.

EXAMPLE BOARD LAYOUT

DGK0008A

TM VSSOP - 1.1 mm max height

SMALL OUTLINE PACKAGE



LAND PATTERN EXAMPLE
EXPOSED METAL SHOWN
SCALE: 15X



SOLDER MASK DETAILS

4214862/A 04/2023

NOTES: (continued)

6. Publication IPC-7351 may have alternate designs.
7. Solder mask tolerances between and around signal pads can vary based on board fabrication site.
8. Vias are optional depending on application, refer to device data sheet. If any vias are implemented, refer to their locations shown on this view. It is recommended that vias under paste be filled, plugged or tented.
9. Size of metal pad may vary due to creepage requirement.

EXAMPLE STENCIL DESIGN

DGK0008A

TM VSSOP - 1.1 mm max height

SMALL OUTLINE PACKAGE

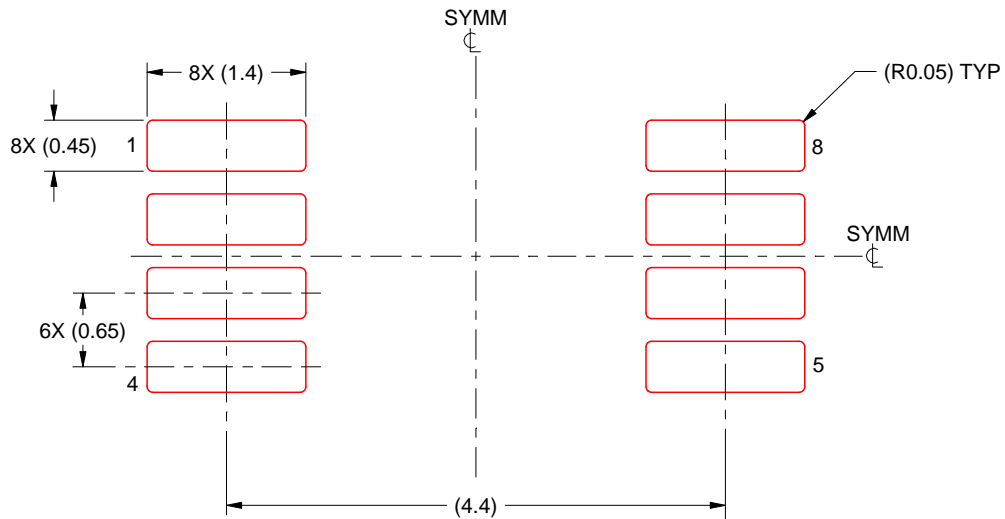

SOLDER PASTE EXAMPLE
SCALE: 15X

4214862/A 04/2023

NOTES: (continued)

11. Laser cutting apertures with trapezoidal walls and rounded corners may offer better paste release. IPC-7525 may have alternate design recommendations.
12. Board assembly site may have different recommendations for stencil design.

重要なお知らせと免責事項

TI は、技術データと信頼性データ (データシートを含みます)、設計リソース (リファレンス デザインを含みます)、アプリケーションや設計に関する各種アドバイス、Web ツール、安全性情報、その他のリソースを、欠陥が存在する可能性のある「現状のまま」提供しており、商品性および特定目的に対する適合性の黙示保証、第三者の知的財産権の非侵害保証を含むいかなる保証も、明示的または黙示的にかかわらず拒否します。

これらのリソースは、TI 製品を使用する設計の経験を積んだ開発者への提供を意図したものです。(1) お客様のアプリケーションに適した TI 製品の選定、(2) お客様のアプリケーションの設計、検証、試験、(3) お客様のアプリケーションに該当する各種規格や、その他のあらゆる安全性、セキュリティ、規制、または他の要件への確実な適合に関する責任を、お客様のみが単独で負うものとし、

上記の各種リソースは、予告なく変更される可能性があります。これらのリソースは、リソースで説明されている TI 製品を使用するアプリケーションの開発の目的でのみ、TI はその使用をお客様に許諾します。これらのリソースに関して、他の目的で複製することや掲載することは禁止されています。TI や第三者の知的財産権のライセンスが付与されている訳ではありません。お客様は、これらのリソースを自身で使用した結果発生するあらゆる申し立て、損害、費用、損失、責任について、TI およびその代理人を完全に補償するものとし、TI は一切の責任を拒否します。

TI の製品は、[TI の販売条件](#)、[TI の総合的な品質ガイドライン](#)、[ti.com](#) または TI 製品などに関連して提供される他の適用条件に従い提供されます。TI がこれらのリソースを提供することは、適用される TI の保証または他の保証の放棄の拡大や変更を意味するものではありません。TI がカスタム、またはカスタマー仕様として明示的に指定していない限り、TI の製品は標準的なカタログに掲載される汎用機器です。

お客様がいかなる追加条項または代替条項を提案する場合も、TI はそれらに異議を唱え、拒否します。

Copyright © 2026, Texas Instruments Incorporated

最終更新日 : 2025 年 10 月