

# OPAx316-Q1 10MHz、レール・ツー・レール入出力、低電圧、1.8V CMOSオペアンプ

## 1 特長

- 車載アプリケーションに対応
- 下記内容でAEC-Q100認定済み：
  - デバイス温度グレード1: 動作時周囲温度範囲  $-40^{\circ}\text{C} \sim +125^{\circ}\text{C}$
  - デバイスHBM ESD分類レベル3A
  - デバイスCDM ESD分類レベルC5
- ユニティ・ゲイン帯域幅: 10MHz
- 低い $I_Q$ : 400 $\mu\text{A}/\text{ch}$
- 広い電源電圧範囲: 1.8V $\sim$ 5.5V
- 低ノイズ: 1kHz時に11nV/ $\sqrt{\text{Hz}}$
- 低い入力バイアス電流:  $\pm 5\text{pA}$
- オフセット電圧:  $\pm 0.5\text{mV}$
- ユニティ・ゲイン安定
- RFI-EMIフィルタを内蔵
- 拡張温度範囲:  $-40^{\circ}\text{C} \sim +125^{\circ}\text{C}$

## 2 アプリケーション

- 車載用アプリケーション
  - ADAS (先進運転支援システム)
  - 車体エレクトロニクスおよび照明
  - 電流検出
  - バッテリ管理システム

## 3 概要

OPAx316-Q1ファミリのシングルおよびデュアル・オペアンプは、新世代の汎用、低消費電力のオペアンプを代表する製品です。レール・ツー・レールの入力および出力、低い静止電流(標準値400 $\mu\text{A}/\text{ch}$ )、10MHzの広い帯域幅、非常に低いノイズ(1kHzにおいて11nV/ $\sqrt{\text{Hz}}$ )という特長から、このファミリは優れた速度/電力比を必要とする回路に適しています。

入力バイアス電流が小さいため、これらのオペアンプはメガオームのソース・インピーダンスを持つアプリケーションに対応できます。OPAx316-Q1は入力バイアス電流が小さいため、電流ノイズもごく小さく、高インピーダンスのセンサ・インターフェイスに魅力的な選択肢です。

OPAx316-Q1は堅牢に設計されており、ユニティ・ゲイン安定、RFIおよびEMI除去フィルタの内蔵、オーバードライブ状態で位相反転が発生しない、高い静電放電(ESD)保護(4kV HBM)という特長から、回路設計者が簡単に使用できます。

これらのデバイスは、最小1.8V ( $\pm 0.9\text{V}$ )、最大5.5V ( $\pm 2.75\text{V}$ )の低電圧での動作に最適化されています。この車載グレードの低電圧CMOSオペアンプが追加されたことにより、広い帯域幅、低ノイズ、低消費電力で、広範なアプリケーションの要求を満たす製品ファミリとなりました。

### 製品情報<sup>(1)</sup>

| 型番         | パッケージ      | 本体サイズ(typ)    |
|------------|------------|---------------|
| OPA316-Q1  | SOT-23 (5) | 1.60mmx2.90mm |
| OPA2316-Q1 | VSSOP (8)  | 3.00mmx3.00mm |
| OPA4316-Q1 | TSSOP (14) | 4.40mmx5.00mm |

(1) 利用可能なすべてのパッケージについては、このデータシートの末尾にある注文情報を参照してください。

### シングル・ポールのローパス・フィルタ

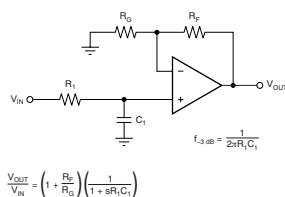

### 10MHz帯域幅での低い消費電流(400 $\mu\text{A}/\text{ch}$ )

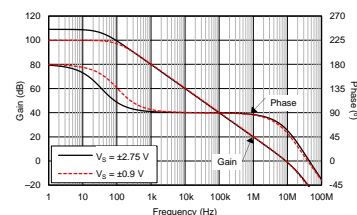

## 目次

|          |  |           |           |                                       |           |
|----------|--|-----------|-----------|---------------------------------------|-----------|
| 1        | 特長                                     | 1         | 7.4       | Device Functional Modes               | 20        |
| 2        | アプリケーション                               | 1         | <b>8</b>  | <b>Application and Implementation</b> | <b>21</b> |
| 3        | 概要                                     | 1         | 8.1       | Application Information               | 21        |
| 4        | 改訂履歴                                   | 2         | 8.2       | Typical Application                   | 22        |
| 5        | <b>Pin Configuration and Functions</b> | <b>3</b>  | <b>9</b>  | <b>Power Supply Recommendations</b>   | <b>25</b> |
| 6        | <b>Specifications</b>                  | <b>6</b>  | <b>10</b> | <b>Layout</b>                         | <b>26</b> |
| 6.1      | Absolute Maximum Ratings               | 6         | 10.1      | Layout Guidelines                     | 26        |
| 6.2      | ESD Ratings                            | 6         | 10.2      | Layout Example                        | 26        |
| 6.3      | Recommended Operating Conditions       | 6         | <b>11</b> | <b>デバイスおよびドキュメントのサポート</b>             | <b>27</b> |
| 6.4      | Thermal Information: OPA316-Q1         | 7         | 11.1      | ドキュメントのサポート                           | 27        |
| 6.5      | Thermal Information: OPA2316-Q1        | 8         | 11.2      | 関連リンク                                 | 27        |
| 6.6      | Thermal Information: OPA4316-Q1        | 9         | 11.3      | ドキュメントの更新通知を受け取る方法                    | 27        |
| 6.7      | Electrical Characteristics             | 10        | 11.4      | コミュニティ・リソース                           | 27        |
| 6.8      | Typical Characteristics                | 12        | 11.5      | 商標                                    | 27        |
| <b>7</b> | <b>Detailed Description</b>            | <b>18</b> | 11.6      | 静電気放電に関する注意事項                         | 27        |
| 7.1      | Overview                               | 18        | 11.7      | Glossary                              | 27        |
| 7.2      | Functional Block Diagram               | 18        | <b>12</b> | <b>メカニカル、パッケージ、および注文情報</b>            | <b>28</b> |
| 7.3      | Feature Description                    | 18        |           |                                       |           |

## 4 改訂履歴

### 2016年11月発行のものから更新

**Page**

|   |   |    |
|---|---|----|
| • | CDM分類レベルをC6から変更   | 1  |
| • | 「製品情報」表からOPA2316S-Q1のパッケージおよび本体サイズの情報を削除  | 1  |
| • | 「製品情報」表、「熱に関する情報」表、ピン配置図からSC70 (5) (OPA316-Q1)、DFN (8)、MSOP (8)、SOIC (8) (OPA2316-Q1)、SOIC (14)パッケージ(OPA4316-Q1)を削除 | 1  |
| • | Deleted OPA2316S-Q1 pin diagram and Pin Functions table in <i>Pin Configurations and Functions</i> section          | 3  |
| • | Deleted D (SOIC) package from OPA4316-Q1 pin diagram in Pin Configurations and Functions section                    | 5  |
| • | Changed CDM rating from $\pm 1500$ V to $\pm 750$ V   | 6  |
| • | Deleted OPA2316S-Q1 device thermal information in the <i>Thermal Information</i> table                              | 7  |
| • | Added thermal information for OPA4316-Q1 device   | 9  |
| • | 削除「ドキュメントのサポート」セクションでTIドキュメント参照のフォーマットに含まれる括弧内の文書番号   | 27 |

## 5 Pin Configuration and Functions

**OPA316-Q1 DBV Package  
5-Pin SOT-23  
Top View**

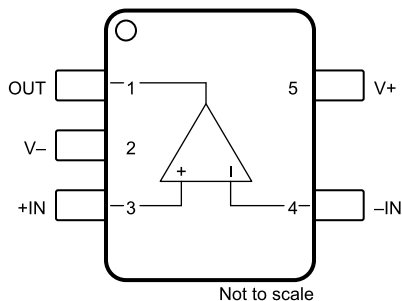

**Pin Functions: OPA316-Q1**

| PIN  |     | I/O | DESCRIPTION  |
|------|-----|-----|--|
| NAME | NO. |     |  |
| -IN  | 4   | I   | Inverting input  |
| +IN  | 3   | I   | Noninverting input                                       |
| V-   | 2   | —   | Negative supply or ground (for single-supply operation). |
| V+   | 5   | —   | Positive supply  |
| OUT  | 1   | O   | Output   |

OPA2316-Q1 DGK Package  
8-Pin VSSOP  
Top View

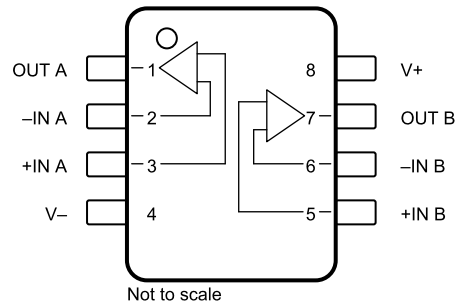

Pin Functions: OPA2316-Q1

| PIN   |     | I/O | DESCRIPTION  |
|-------|-----|-----|--|
| NAME  | NO. |     |  |
| -IN A | 2   | I   | Inverting input, channel A                               |
| +IN A | 3   | I   | Noninverting input, channel A                            |
| -IN B | 6   | I   | Inverting input, channel B                               |
| +IN B | 5   | I   | Noninverting input, channel B                            |
| OUT A | 1   | O   | Output, channel A  |
| OUT B | 7   | O   | Output, channel B  |
| V-    | 4   | —   | Negative supply or ground (for single-supply operation). |
| V+    | 8   | —   | Positive supply  |

**OPA4316-Q1 PW Package  
14-Pin TSSOP  
Top View**

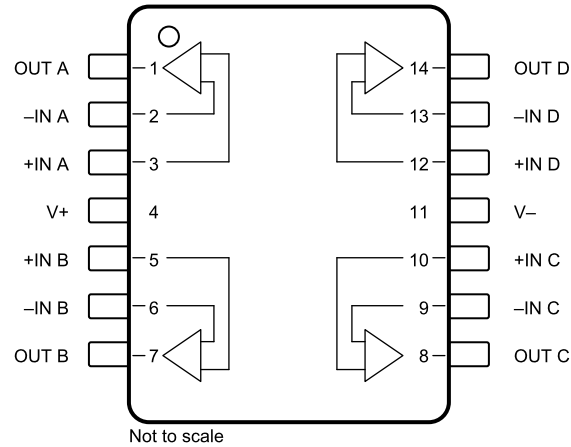

**Pin Functions: OPA4316-Q1**

| PIN   |     | I/O | DESCRIPTION   |
|-------|-----|-----|---|
| NAME  | NO. |     |   |
| -IN A | 2   | I   | Inverting input, channel A                              |
| +IN A | 3   | I   | Noninverting input, channel A                           |
| -IN B | 6   | I   | Inverting input, channel B                              |
| +IN B | 5   | I   | Noninverting input, channel B                           |
| -IN C | 9   | I   | Inverting input, channel C                              |
| +IN C | 10  | I   | Noninverting input, channel C                           |
| -IN D | 13  | I   | Inverting input, channel D                              |
| +IN D | 12  | I   | Noninverting input, channel D                           |
| OUT A | 1   | O   | Output, channel A                                       |
| OUT B | 7   | O   | Output, channel B                                       |
| OUT C | 8   | O   | Output, channel C                                       |
| OUT D | 14  | O   | Output, channel D                                       |
| V-    | 11  | —   | Negative supply or ground (for single-supply operation) |
| V+    | 4   | —   | Positive supply   |

## 6 Specifications

### 6.1 Absolute Maximum Ratings

over operating free-air temperature (unless otherwise noted)<sup>(1)</sup>

|                                     |                        |              | MIN   | MAX                     | UNIT |
|-------------------------------------|------------------------|--------------|---|-------------------------|------|
| Supply voltage                      |                        |              | 7   |                         | V    |
| Signal input pins                   | Voltage <sup>(2)</sup> | Common-mode  | (V <sub>-</sub> ) - 0.5                     | (V <sub>+</sub> ) + 0.5 | V    |
|                                     |                        | Differential | (V <sub>+</sub> ) - (V <sub>-</sub> ) + 0.2 |                         | V    |
|                                     | Current <sup>(2)</sup> |              | -10   | 10                      | mA   |
| Output short-circuit <sup>(3)</sup> |                        |              | Continuous                                  |                         |      |
| T <sub>A</sub>                      | Operating temperature  |              | -55   | 150                     | °C   |
| T <sub>J</sub>                      | Junction temperature   |              |   | 150                     | °C   |
| T <sub>stg</sub>                    | Storage temperature    |              | -65   | 150                     | °C   |

- (1) Stresses beyond those listed under *Absolute Maximum Ratings* may cause permanent damage to the device. These are stress ratings only, which do not imply functional operation of the device at these or any other conditions beyond those indicated under *Recommended Operating Conditions*. Exposure to absolute-maximum-rated conditions for extended periods may affect device reliability.
- (2) Input pins are diode-clamped to the power-supply rails. Current limit input signals that can swing more than 0.5 V beyond the supply rails to 10 mA or less.
- (3) Short-circuit to ground, one amplifier per package.

### 6.2 ESD Ratings

|                    |                         |   | VALUE | UNIT |
|--------------------|-------------------------|---|-------|------|
| V <sub>(ESD)</sub> | Electrostatic discharge | Human-body model (HBM), per AEC Q100-002 <sup>(1)</sup> | ±4000 | V    |
|                    |                         | Charged-device model (CDM), per AEC Q100-011            | ±750  |      |

- (1) AEC Q100-002 indicates that HBM stressing shall be in accordance with the ANSI/ESDA/JEDEC JS-001 specification.

### 6.3 Recommended Operating Conditions

over operating free-air temperature range (unless otherwise noted)

|                |                       |  | MIN | MAX | UNIT |
|----------------|-----------------------|--|-----|-----|------|
| V <sub>S</sub> | Supply voltage        |  | 1.8 | 5.5 | V    |
|                | Specified temperature |  | -40 | 125 | °C   |

## 6.4 Thermal Information: OPA316-Q1

| THERMAL METRIC <sup>(1)</sup> |   | OPA316-Q1    | UNIT |
|-------------------------------|---|--------------|------|
|                               |   | DBV (SOT-23) |      |
|                               |   | 5 PINS       |      |
| $R_{\theta JA}$               | Junction-to-ambient thermal resistance <sup>(2)</sup>       | 221.7        | °C/W |
| $R_{\theta JC(top)}$          | Junction-to-case(top) thermal resistance <sup>(3)</sup>     | 144.7        | °C/W |
| $R_{\theta JB}$               | Junction-to-board thermal resistance <sup>(4)</sup>         | 49.7         | °C/W |
| $\Psi_{JT}$                   | Junction-to-top characterization parameter <sup>(5)</sup>   | 26.1         | °C/W |
| $\Psi_{JB}$                   | Junction-to-board characterization parameter <sup>(6)</sup> | 49           | °C/W |
| $R_{\theta JC(bot)}$          | Junction-to-case(bottom) thermal resistance <sup>(7)</sup>  | N/A          | °C/W |

- (1) For more information about traditional and new thermal metrics, see the [Semiconductor and IC Package Thermal Metrics](#) application report.
- (2) The junction-to-ambient thermal resistance under natural convection is obtained in a simulation on a JEDEC-standard, high-K board, as specified in JESD51-7, in an environment described in JESD51-2a.
- (3) The junction-to-case (top) thermal resistance is obtained by simulating a cold plate test on the package top. No specific JEDEC-standard test exists, but a close description can be found in the ANSI SEMI standard G30-88.
- (4) The junction-to-board thermal resistance is obtained by simulating in an environment with a ring cold plate fixture to control the PCB temperature, as described in JESD51-8.
- (5) The junction-to-top characterization parameter,  $\Psi_{JT}$ , estimates the junction temperature of a device in a real system and is extracted from the simulation data for obtaining  $R_{\theta JA}$ , using a procedure described in JESD51-2a (sections 6 and 7).
- (6) The junction-to-board characterization parameter,  $\Psi_{JB}$ , estimates the junction temperature of a device in a real system and is extracted from the simulation data for obtaining  $R_{\theta JA}$ , using a procedure described in JESD51-2a (sections 6 and 7).
- (7) The junction-to-case (bottom) thermal resistance is obtained by simulating a cold plate test on the exposed (power) pad. No specific JEDEC standard test exists, but a close description can be found in the ANSI SEMI standard G30-88.

## 6.5 Thermal Information: OPA2316-Q1

| THERMAL METRIC <sup>(1)</sup> |   | OPA2316-Q1  | UNIT |
|-------------------------------|---|-------------|------|
|                               |   | DGK (VSSOP) |      |
|                               |   | 8 PINS      |      |
| $R_{\theta JA}$               | Junction-to-ambient thermal resistance <sup>(2)</sup>       | 186.6       | °C/W |
| $R_{\theta JC(top)}$          | Junction-to-case(top) thermal resistance <sup>(3)</sup>     | 78.8        | °C/W |
| $R_{\theta JB}$               | Junction-to-board thermal resistance <sup>(4)</sup>         | 107.9       | °C/W |
| $\Psi_{JT}$                   | Junction-to-top characterization parameter <sup>(5)</sup>   | 15.5        | °C/W |
| $\Psi_{JB}$                   | Junction-to-board characterization parameter <sup>(6)</sup> | 106.3       | °C/W |
| $R_{\theta JC(bot)}$          | Junction-to-case(bottom) thermal resistance <sup>(7)</sup>  | N/A         | °C/W |

- (1) For more information about traditional and new thermal metrics, see the [Semiconductor and IC Package Thermal Metrics](#) application report.
- (2) The junction-to-ambient thermal resistance under natural convection is obtained in a simulation on a JEDEC-standard, high-K board, as specified in JESD51-7, in an environment described in JESD51-2a.
- (3) The junction-to-case (top) thermal resistance is obtained by simulating a cold plate test on the package top. No specific JEDEC-standard test exists, but a close description can be found in the ANSI SEMI standard G30-88.
- (4) The junction-to-board thermal resistance is obtained by simulating in an environment with a ring cold plate fixture to control the PCB temperature, as described in JESD51-8.
- (5) The junction-to-top characterization parameter,  $\Psi_{JT}$ , estimates the junction temperature of a device in a real system and is extracted from the simulation data for obtaining  $R_{\theta JA}$ , using a procedure described in JESD51-2a (sections 6 and 7).
- (6) The junction-to-board characterization parameter,  $\Psi_{JB}$ , estimates the junction temperature of a device in a real system and is extracted from the simulation data for obtaining  $R_{\theta JA}$ , using a procedure described in JESD51-2a (sections 6 and 7).
- (7) The junction-to-case (bottom) thermal resistance is obtained by simulating a cold plate test on the exposed (power) pad. No specific JEDEC standard test exists, but a close description can be found in the ANSI SEMI standard G30-88.

## 6.6 Thermal Information: OPA4316-Q1

| THERMAL METRIC <sup>(1)</sup> |   | OPA4316-Q1 | UNIT |
|-------------------------------|---|------------|------|
|                               |   | PW (TSSOP) |      |
|                               |   | 14 PINS    |      |
| $R_{\theta JA}$               | Junction-to-ambient thermal resistance <sup>(2)</sup>       | 117.2      | °C/W |
| $R_{\theta JC(top)}$          | Junction-to-case(top) thermal resistance <sup>(3)</sup>     | 46.2       | °C/W |
| $R_{\theta JB}$               | Junction-to-board thermal resistance <sup>(4)</sup>         | 58.9       | °C/W |
| $\Psi_{JT}$                   | Junction-to-top characterization parameter <sup>(5)</sup>   | 4.9        | °C/W |
| $\Psi_{JB}$                   | Junction-to-board characterization parameter <sup>(6)</sup> | 58.3       | °C/W |
| $R_{\theta JC(bot)}$          | Junction-to-case(bottom) thermal resistance <sup>(7)</sup>  | N/A        | °C/W |

- (1) For more information about traditional and new thermal metrics, see the [Semiconductor and IC Package Thermal Metrics](#) application report.
- (2) The junction-to-ambient thermal resistance under natural convection is obtained in a simulation on a JEDEC-standard, high-K board, as specified in JESD51-7, in an environment described in JESD51-2a.
- (3) The junction-to-case (top) thermal resistance is obtained by simulating a cold plate test on the package top. No specific JEDEC-standard test exists, but a close description can be found in the ANSI SEMI standard G30-88.
- (4) The junction-to-board thermal resistance is obtained by simulating in an environment with a ring cold plate fixture to control the PCB temperature, as described in JESD51-8.
- (5) The junction-to-top characterization parameter,  $\Psi_{JT}$ , estimates the junction temperature of a device in a real system and is extracted from the simulation data for obtaining  $R_{\theta JA}$ , using a procedure described in JESD51-2a (sections 6 and 7).
- (6) The junction-to-board characterization parameter,  $\Psi_{JB}$ , estimates the junction temperature of a device in a real system and is extracted from the simulation data for obtaining  $R_{\theta JA}$ , using a procedure described in JESD51-2a (sections 6 and 7).
- (7) The junction-to-case (bottom) thermal resistance is obtained by simulating a cold plate test on the exposed (power) pad. No specific JEDEC standard test exists, but a close description can be found in the ANSI SEMI standard G30-88.

## 6.7 Electrical Characteristics

 $V_S$  (total supply voltage) = (V+) – (V–) = 1.8 V to 5.5 V.

 at  $T_A = 25^\circ\text{C}$ ,  $R_L = 10\text{ k}\Omega$  connected to  $V_S / 2$ ,  $V_{CM} = V_S / 2$ , and  $V_{OUT} = V_S / 2$ , unless otherwise noted

| PARAMETER                  |  | TEST CONDITIONS   | MIN          | TYP             | MAX          | UNIT                                |
|----------------------------|--|---|--------------|-----------------|--------------|-------------------------------------|
| <b>OFFSET VOLTAGE</b>      |  |   |              |                 |              |                                     |
| $V_{OS}$                   | Input offset voltage                             | $V_S = 5\text{ V}$  |              | $\pm 0.5$       | $\pm 2.5$    | mV                                  |
|                            |  | $V_S = 5\text{ V}$ , $T_A = -40^\circ\text{C}$ to $125^\circ\text{C}$   |              |                 | $\pm 3.5$    | mV                                  |
| $dV_{OS}/dT$               | Drift  | $V_S = 5\text{ V}$ , $T_A = -40^\circ\text{C}$ to $125^\circ\text{C}$   |              | $\pm 2$         | $\pm 10$     | $\mu\text{V}/^\circ\text{C}$        |
| PSRR                       | vs power supply                                  | $V_S = 1.8\text{ V} - 5.5\text{ V}$ , $V_{CM} = (V-)$   |              | $\pm 30$        | $\pm 150$    | $\mu\text{V}/\text{V}$              |
|                            |  | $V_S = 1.8\text{ V} - 5.5\text{ V}$ , $V_{CM} = (V-)$ , $T_A = -40^\circ\text{C}$ to $125^\circ\text{C}$  |              |                 | $\pm 250$    | $\mu\text{V}/\text{V}$              |
|                            | Channel separation, dc                           | At dc   |              | 10              |              | $\mu\text{V}/\text{V}$              |
| <b>INPUT VOLTAGE RANGE</b> |  |   |              |                 |              |                                     |
| $V_{CM}$                   | Common-mode voltage                              | $V_S = 1.8\text{ V}$ to $2.5\text{ V}$  | $(V-) - 0.2$ |                 | $(V+)$       | V                                   |
|                            |  | $V_S = 2.5\text{ V}$ to $5.5\text{ V}$  | $(V-) - 0.2$ |                 | $(V+) + 0.2$ | V                                   |
| CMRR                       | Common-mode rejection ratio                      | $V_S = 1.8\text{ V}$ , $(V-) - 0.2\text{ V} < V_{CM} < (V+) - 1.4\text{ V}$ , $T_A = -40^\circ\text{C}$ to $125^\circ\text{C}$                            | 70           | 86              |              | dB                                  |
|                            |  | $V_S = 5.5\text{ V}$ , $(V-) - 0.2\text{ V} < V_{CM} < (V+) - 1.4\text{ V}$ , $T_A = -40^\circ\text{C}$ to $125^\circ\text{C}$                            | 76           | 90              |              | dB                                  |
|                            |  | $V_S = 1.8\text{ V}$ , $V_{CM} = -0.2\text{ V}$ to $1.8\text{ V}$ , $T_A = -40^\circ\text{C}$ to $125^\circ\text{C}$                                      | 57           | 72              |              | dB                                  |
|                            |  | $V_S = 5.5\text{ V}$ , $V_{CM} = -0.2\text{ V}$ to $5.7\text{ V}$ , $T_A = -40^\circ\text{C}$ to $125^\circ\text{C}$                                      | 65           | 80              |              | dB                                  |
| <b>INPUT BIAS CURRENT</b>  |  |   |              |                 |              |                                     |
| $I_B$                      | Input bias current                               |   |              | $\pm 5$         | $\pm 15$     | pA                                  |
|                            |  | $T_A = -40^\circ\text{C}$ to $125^\circ\text{C}$  |              |                 | $\pm 15$     | nA                                  |
| $I_{OS}$                   | Input offset current                             |   |              | $\pm 2$         | $\pm 15$     | pA                                  |
|                            |  | $T_A = -40^\circ\text{C}$ to $125^\circ\text{C}$  |              |                 | $\pm 8$      | nA                                  |
| <b>NOISE</b>               |  |   |              |                 |              |                                     |
| $E_n$                      | Input voltage noise (peak-to-peak)               | $V_S = 5\text{ V}$ , $f = 0.1\text{ Hz}$ to $10\text{ Hz}$  |              | 3               |              | $\mu\text{V}_{PP}$                  |
| $e_n$                      | Input voltage noise density                      | $V_S = 5\text{ V}$ , $f = 1\text{ kHz}$   |              | 11              |              | $\text{nV}/\sqrt{\text{Hz}}$        |
| $i_n$                      | Input current noise density                      | $f = 1\text{ kHz}$  |              | 1.3             |              | $\text{fA}/\sqrt{\text{Hz}}$        |
| <b>INPUT IMPEDANCE</b>     |  |   |              |                 |              |                                     |
| $Z_{ID}$                   | Differential                                     |   |              | $2 \parallel 2$ |              | $10^{16}\Omega \parallel \text{pF}$ |
| $Z_{IC}$                   | Common-mode                                      |   |              | $2 \parallel 4$ |              | $10^{11}\Omega \parallel \text{pF}$ |
| <b>OPEN-LOOP GAIN</b>      |  |   |              |                 |              |                                     |
| $A_{OL}$                   | Open-loop voltage gain                           | $V_S = 1.8\text{ V}$ , $(V-) + 0.04\text{ V} < V_O < (V+) - 0.04\text{ V}$ , $R_L = 10\text{ k}\Omega$  | 94           | 100             |              | dB                                  |
|                            |  | $V_S = 5.5\text{ V}$ , $(V-) + 0.05\text{ V} < V_O < (V+) - 0.05\text{ V}$ , $R_L = 10\text{ k}\Omega$  | 104          | 110             |              | dB                                  |
|                            |  | $V_S = 1.8\text{ V}$ , $(V-) + 0.1\text{ V} < V_O < (V+) - 0.1\text{ V}$ , $R_L = 2\text{ k}\Omega$   | 90           | 96              |              | dB                                  |
|                            |  | $V_S = 5.5\text{ V}$ , $(V-) + 0.15\text{ V} < V_O < (V+) - 0.15\text{ V}$ , $R_L = 2\text{ k}\Omega$   | 100          | 106             |              | dB                                  |
|                            |  | $V_S = 5.5\text{ V}$ , $(V-) + 0.05\text{ V} < V_O < (V+) - 0.05\text{ V}$ , $R_L = 10\text{ k}\Omega$ , $T_A = -40^\circ\text{C}$ to $125^\circ\text{C}$ | 86           |                 |              | dB                                  |
|                            |  | $V_S = 5.5\text{ V}$ , $(V-) + 0.15\text{ V} < V_O < (V+) - 0.15\text{ V}$ , $R_L = 2\text{ k}\Omega$ , $T_A = -40^\circ\text{C}$ to $125^\circ\text{C}$  | 84           |                 |              | dB                                  |
| <b>FREQUENCY RESPONSE</b>  |  |   |              |                 |              |                                     |
| GBP                        | Gain bandwidth product                           | $V_S = 5\text{ V}$ , $G = 1$  |              | 10              |              | MHz                                 |
| $\phi_m$                   | Phase margin                                     | $V_S = 5\text{ V}$ , $G = 1$  |              | 60              |              | Degrees                             |
| SR                         | Slew rate  | $V_S = 5\text{ V}$ , $G = 1$  |              | 6               |              | $\text{V}/\mu\text{s}$              |
| $t_s$                      | Settling time                                    | To 0.1%, $V_S = 5\text{ V}$ , 2-V step, $G = 1$ , $C_L = 100\text{ pF}$   |              | 1               |              | $\mu\text{s}$                       |
|                            |  | To 0.01%, $V_S = 5\text{ V}$ , 2-V step, $G = 1$ , $C_L = 100\text{ pF}$  |              | 1.66            |              | $\mu\text{s}$                       |
| $t_{OR}$                   | Overload recovery time                           | $V_S = 5\text{ V}$ , $V_{IN} \times \text{gain} = V_S$  |              | 0.3             |              | $\mu\text{s}$                       |
| THD + N                    | Total harmonic distortion + noise <sup>(1)</sup> | $V_S = 5\text{ V}$ , $V_O = 0.5 V_{RMS}$ , $G = 1$ , $f = 1\text{ kHz}$   |              | 0.0008%         |              |                                     |

(1) Third-order filter; bandwidth = 80 kHz at –3 dB.

**Electrical Characteristics (continued)**
 $V_S$  (total supply voltage) = (V+) – (V–) = 1.8 V to 5.5 V.

 at  $T_A = 25^\circ\text{C}$ ,  $R_L = 10\text{ k}\Omega$  connected to  $V_S / 2$ ,  $V_{CM} = V_S / 2$ , and  $V_{OUT} = V_S / 2$ , unless otherwise noted

| PARAMETER           | TEST CONDITIONS                        | MIN   | TYP | MAX      | UNIT          |               |
|---------------------|--|---|-----|----------|---------------|---------------|
| <b>OUTPUT</b>       |  |   |     |          |               |               |
| $V_O$               | Voltage output swing from supply rails | $V_S = 1.8\text{ V}$ , $R_L = 10\text{ k}\Omega$ , $T_A = -40^\circ\text{C}$ to $125^\circ\text{C}$ |     | 15       | mV            |               |
|                     |  | $V_S = 5.5\text{ V}$ , $R_L = 10\text{ k}\Omega$ , $T_A = -40^\circ\text{C}$ to $125^\circ\text{C}$ |     | 30       | mV            |               |
|                     |  | $V_S = 1.8\text{ V}$ , $R_L = 2\text{ k}\Omega$ , $T_A = -40^\circ\text{C}$ to $125^\circ\text{C}$  |     | 60       | mV            |               |
|                     |  | $V_S = 5.5\text{ V}$ , $R_L = 2\text{ k}\Omega$ , $T_A = -40^\circ\text{C}$ to $125^\circ\text{C}$  |     | 120      | mV            |               |
| $I_{SC}$            | Short-circuit current                  | $V_S = 5\text{ V}$  |     | $\pm 50$ | mA            |               |
| $Z_O$               | Open-loop output impedance             | $V_S = 5\text{ V}$ , $f = 10\text{ MHz}$  |     | 250      | $\Omega$      |               |
| <b>POWER SUPPLY</b> |  |   |     |          |               |               |
| $V_S$               | Specified voltage                      | 1.8   |     | 5.5      | V             |               |
| $I_Q$               | Quiescent current per amplifier        | $V_S = 5\text{ V}$ , $I_O = 0\text{ mA}$ , $T_A = -40^\circ\text{C}$ to $125^\circ\text{C}$         |     | 400      | 500           | $\mu\text{A}$ |
|                     | Power-on time                          | $V_S = 0\text{ V}$ to $5.5\text{ V}$  |     | 200      | $\mu\text{s}$ |               |

### 6.8 Typical Characteristics

at  $T_A = 25^\circ\text{C}$ ,  $V_S = 5.5\text{ V}$ ,  $R_L = 10\text{ k}\Omega$  connected to  $V_S / 2$ ,  $V_{CM} = V_S / 2$ , and  $V_{OUT} = V_S / 2$ , unless otherwise noted.

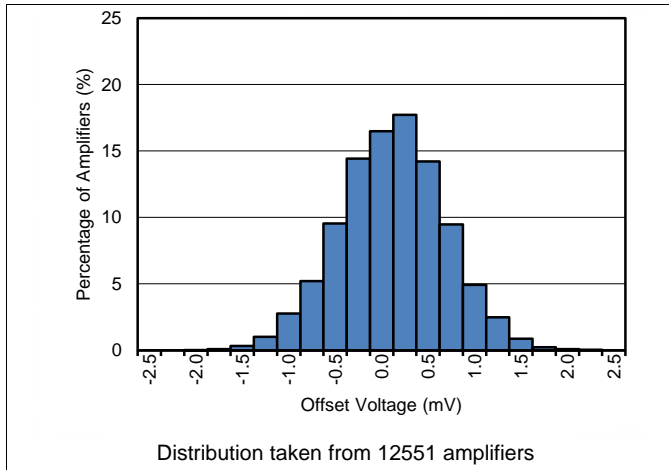

Fig 1. Offset Voltage Production Distribution

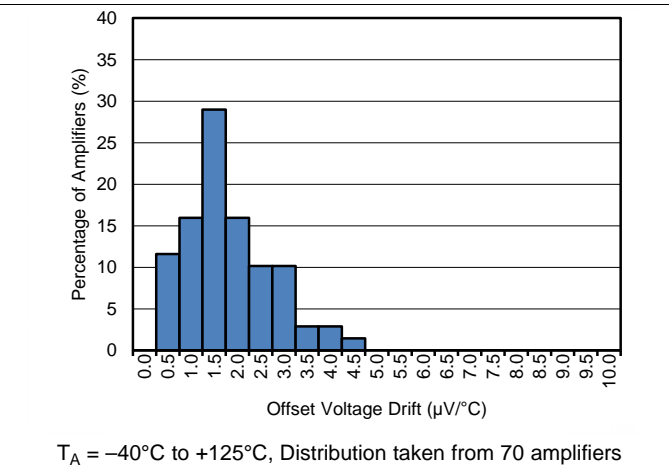

Fig 2. Offset Voltage Drift Distribution

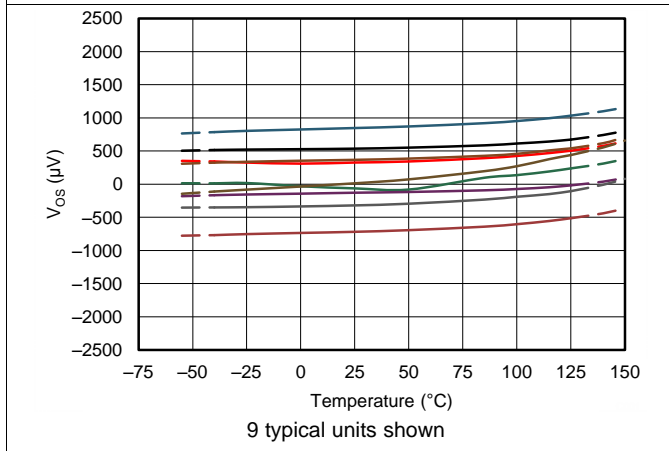

Fig 3. Offset Voltage vs Temperature

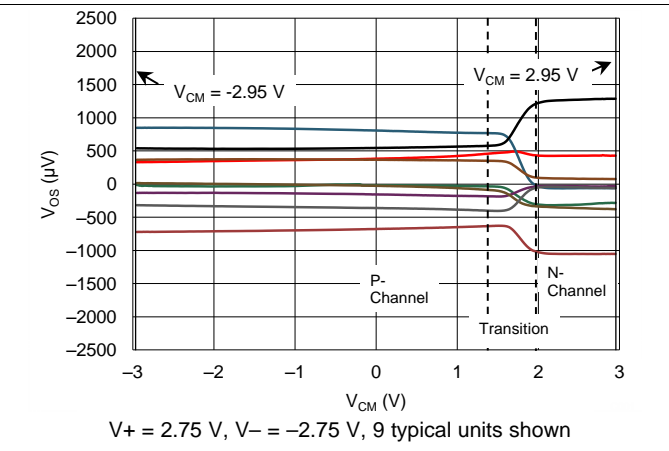

Fig 4. Offset Voltage vs Common-Mode Voltage

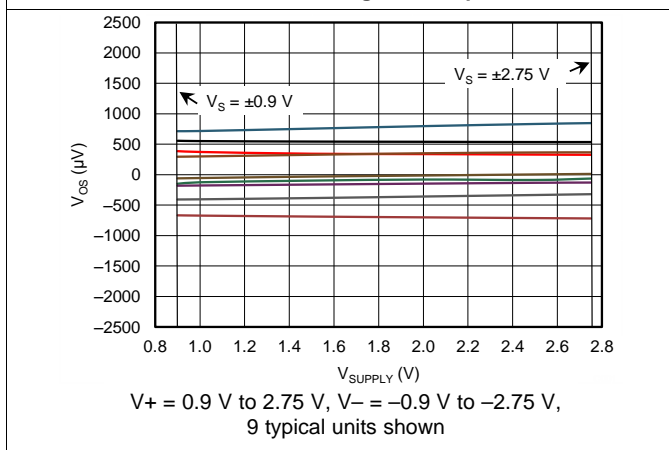

Fig 5. Offset Voltage vs Power Supply

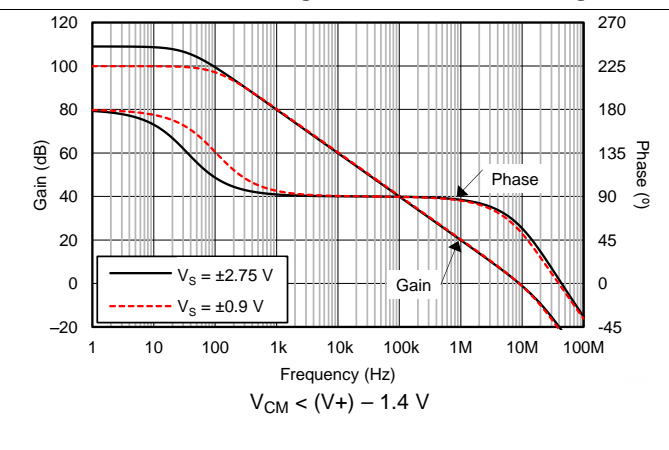
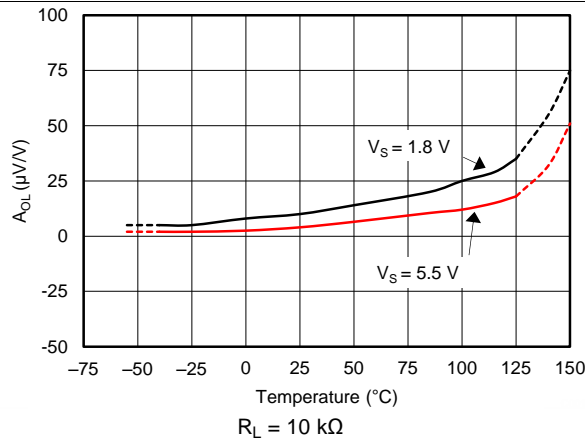

Fig 6. Open-Loop Gain and Phase vs Frequency

**Typical Characteristics (continued)**

at  $T_A = 25^\circ\text{C}$ ,  $V_S = 5.5\text{ V}$ ,  $R_L = 10\text{ k}\Omega$  connected to  $V_S / 2$ ,  $V_{CM} = V_S / 2$ , and  $V_{OUT} = V_S / 2$ , unless otherwise noted.



**Fig. 7. Open-Loop Gain vs Temperature**

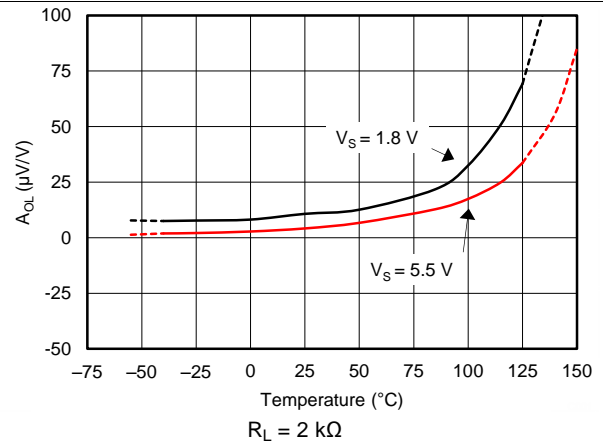

**Fig. 8. Open-Loop Gain vs Temperature**

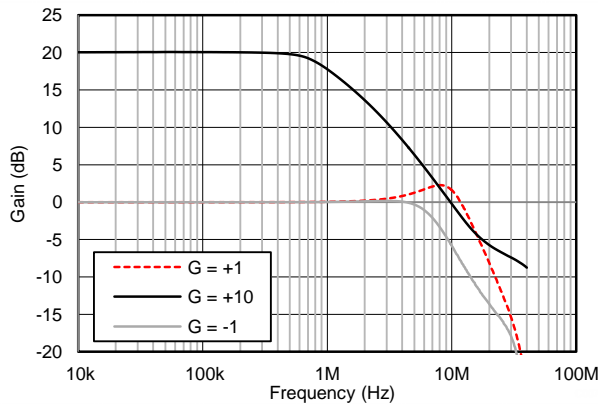

**Fig. 9. Closed-Loop Gain vs Frequency**

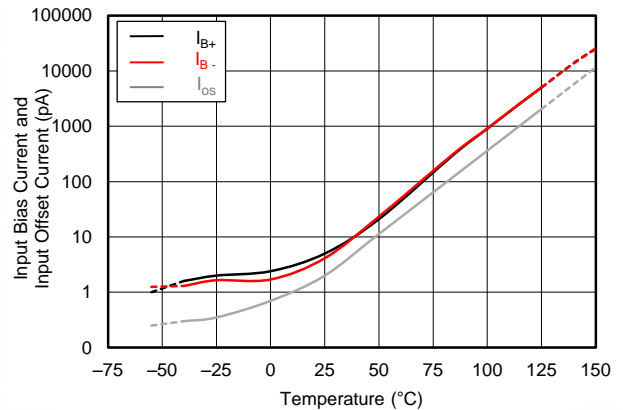

**Fig. 10. Input Bias and Offset Current vs Temperature**

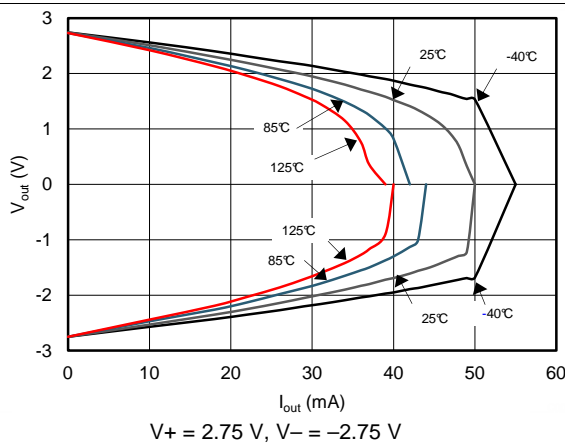

**Fig. 11. Output Voltage Swing vs Output Current**

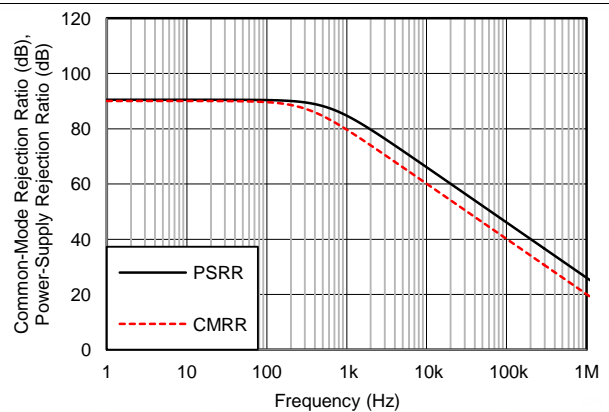

**Fig. 12. CMRR and PSRR vs Frequency (Referred to Input)**

**Typical Characteristics (continued)**

at  $T_A = 25^\circ\text{C}$ ,  $V_S = 5.5\text{ V}$ ,  $R_L = 10\text{ k}\Omega$  connected to  $V_S / 2$ ,  $V_{CM} = V_S / 2$ , and  $V_{OUT} = V_S / 2$ , unless otherwise noted.

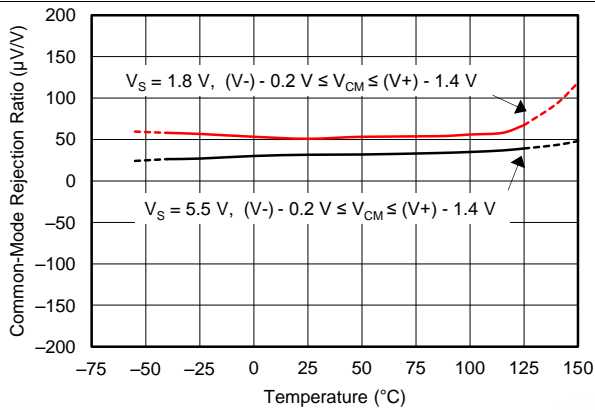

13. CMRR vs Temperature (Narrow Range)

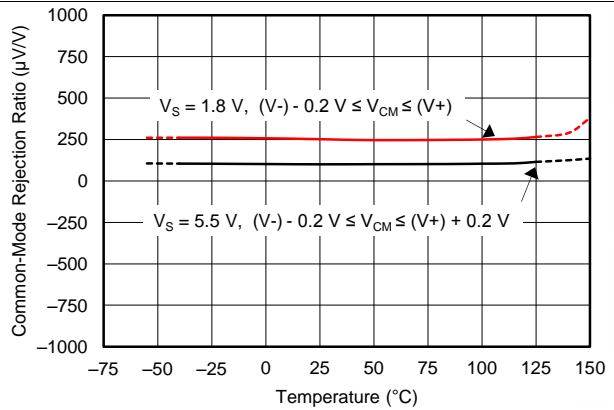

14. CMRR vs Temperature (Wide Range)

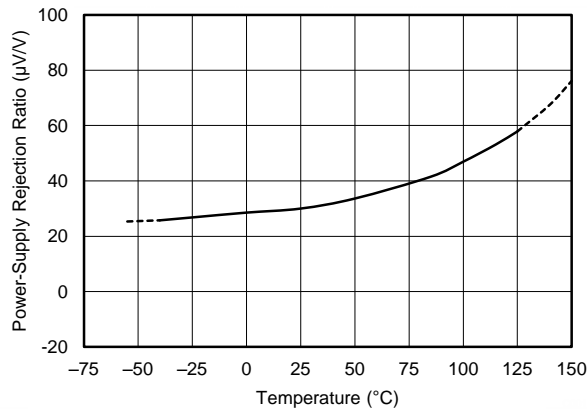

15. PSRR vs Temperature

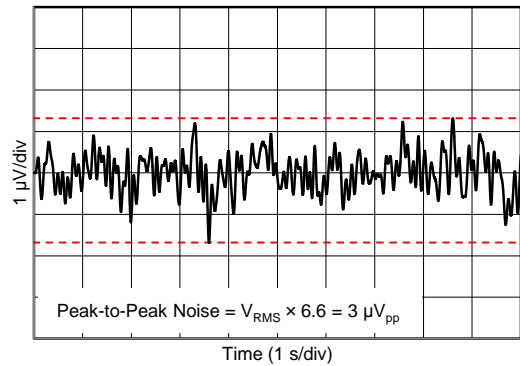

16. 0.1-Hz to 10-Hz Input Voltage Noise

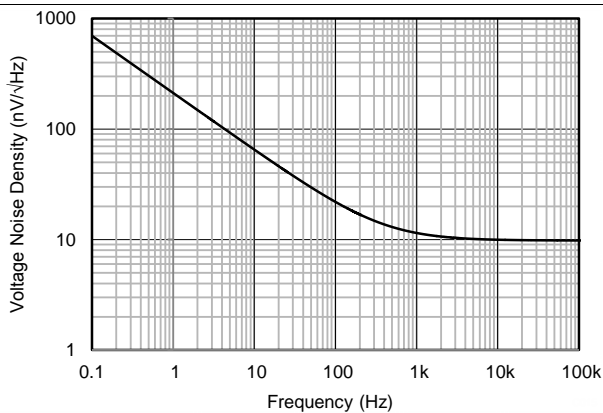

17. Input Voltage Noise Spectral Density vs Frequency

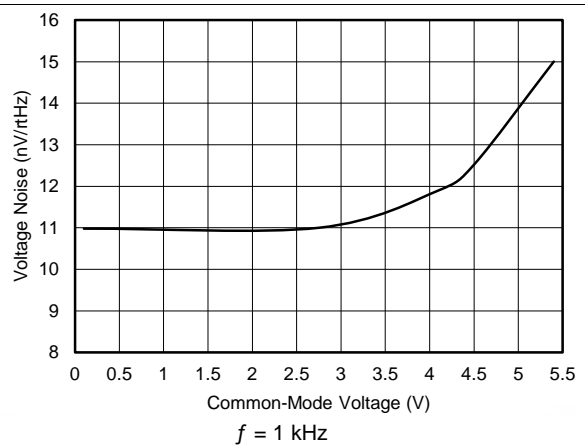

18. Input Voltage Noise vs Common-Mode Voltage

**Typical Characteristics (continued)**

at  $T_A = 25^\circ\text{C}$ ,  $V_S = 5.5\text{ V}$ ,  $R_L = 10\text{ k}\Omega$  connected to  $V_S / 2$ ,  $V_{CM} = V_S / 2$ , and  $V_{OUT} = V_S / 2$ , unless otherwise noted.

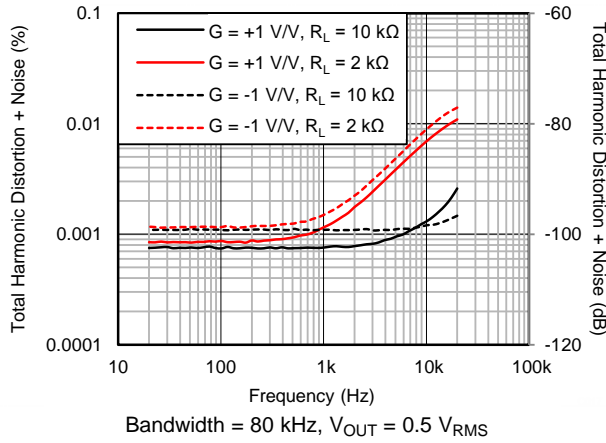

19. THD + N vs Frequency

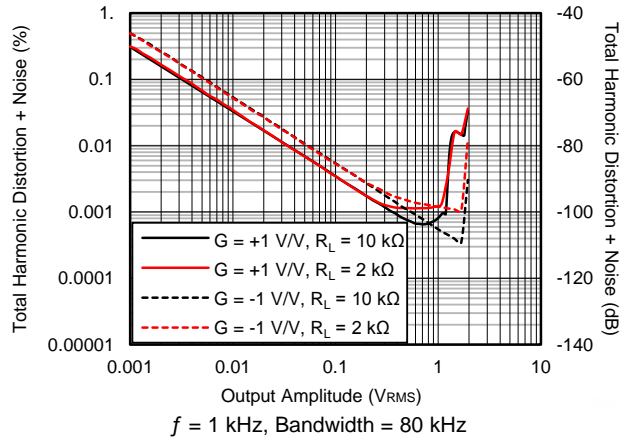

20. THD + N vs Amplitude

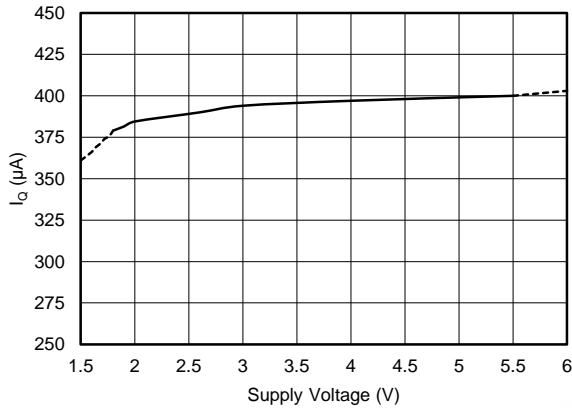

21. Quiescent Current vs Supply Voltage

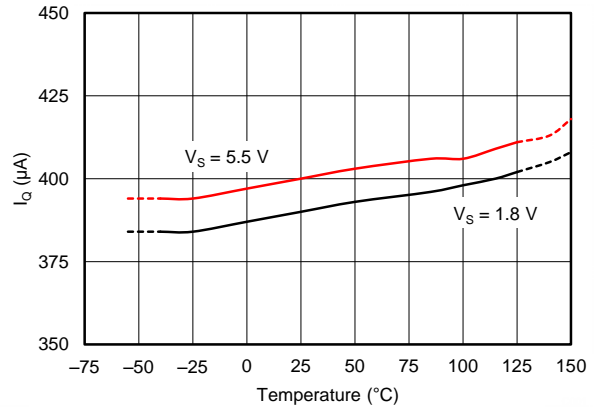

22. Quiescent Current vs Temperature

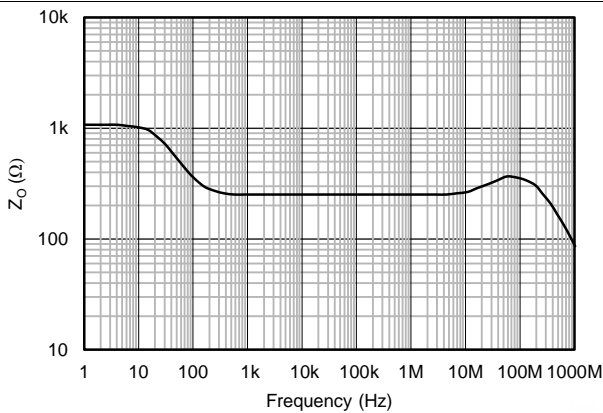

23. Open-Loop Output Impedance vs Frequency

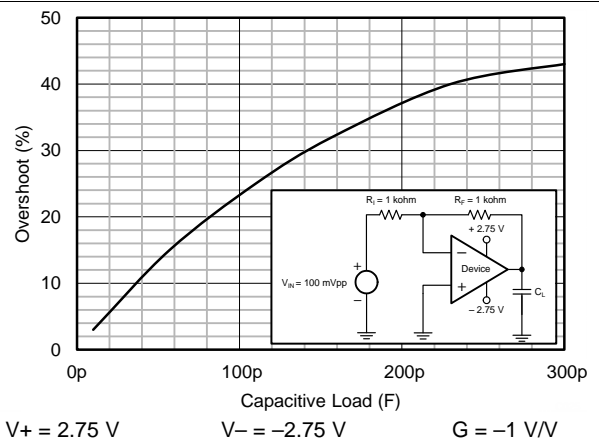

24. Small-Signal Overshoot vs Load Capacitance

Typical Characteristics (continued)

at  $T_A = 25^\circ\text{C}$ ,  $V_S = 5.5\text{ V}$ ,  $R_L = 10\text{ k}\Omega$  connected to  $V_S / 2$ ,  $V_{CM} = V_S / 2$ , and  $V_{OUT} = V_S / 2$ , unless otherwise noted.

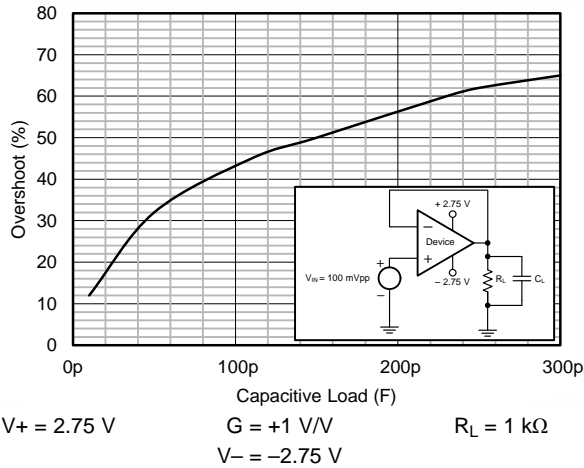

25. Small-Signal Overshoot vs Load Capacitance

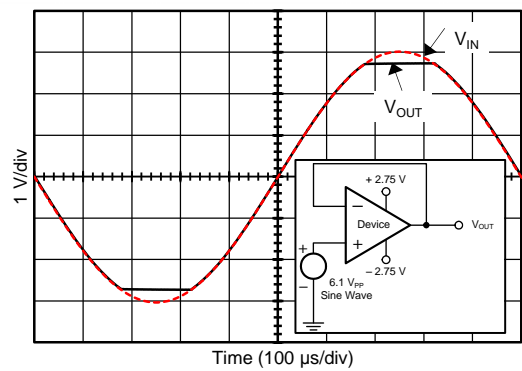

26. No Phase Reversal

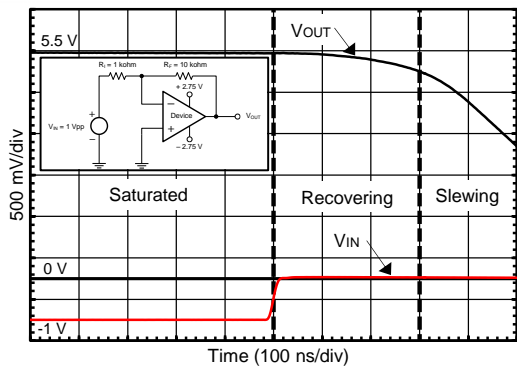

27. Positive Overload Recovery

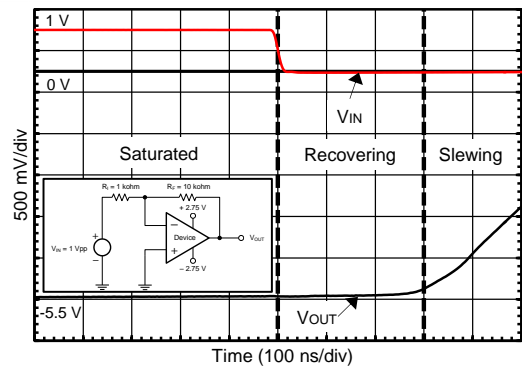

28. Negative Overload Recovery

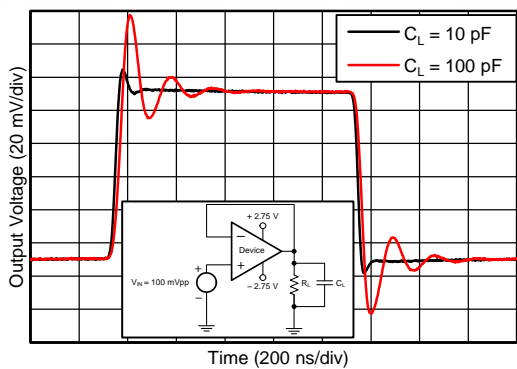

29. Small-Signal Step Response

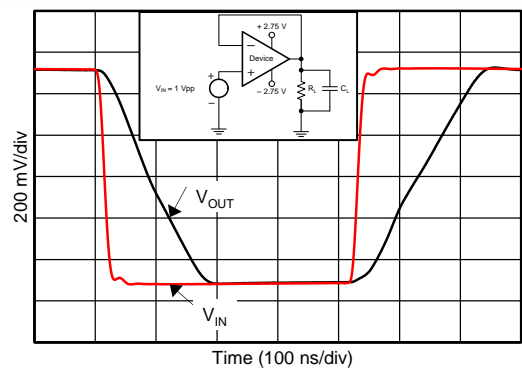

30. Large-Signal Step Response

**Typical Characteristics (continued)**

at  $T_A = 25^\circ\text{C}$ ,  $V_S = 5.5\text{ V}$ ,  $R_L = 10\text{ k}\Omega$  connected to  $V_S / 2$ ,  $V_{CM} = V_S / 2$ , and  $V_{OUT} = V_S / 2$ , unless otherwise noted.

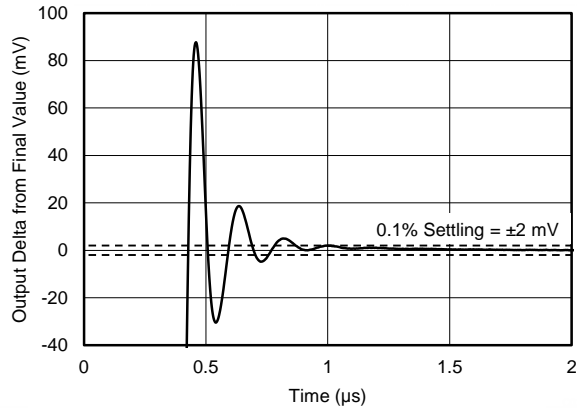

**图 31. Positive Large-Signal Settling Time**

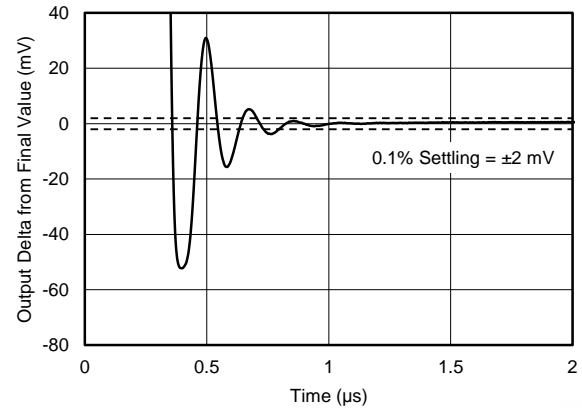

**图 32. Negative Large-Signal Settling Time**

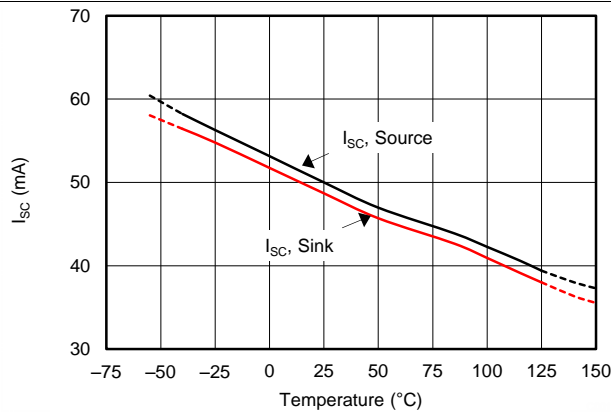

**图 33. Short-Circuit Current vs Temperature**

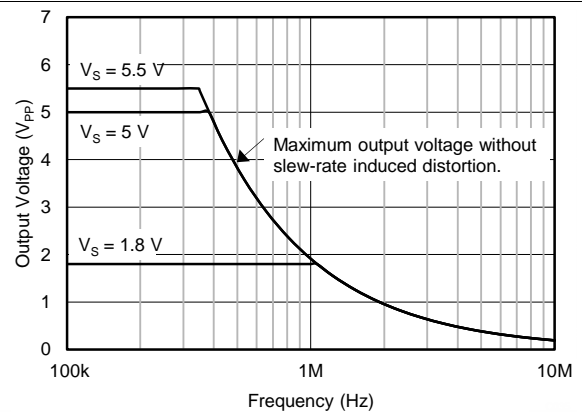

**图 34. Maximum Output Voltage vs Frequency and Supply Voltage**

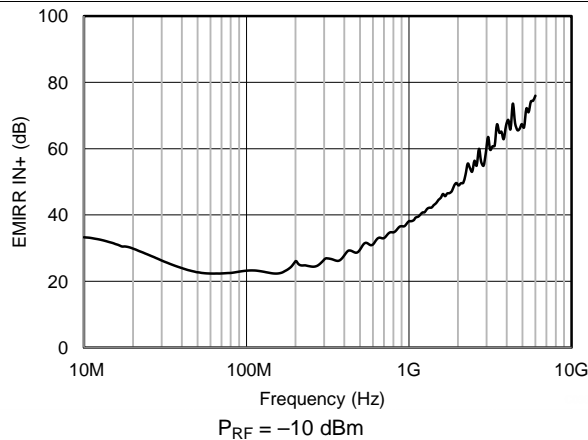

**图 35. Electromagnetic Interference Rejection Ratio Referred to Noninverting Input (EMIRR IN+) vs Frequency**

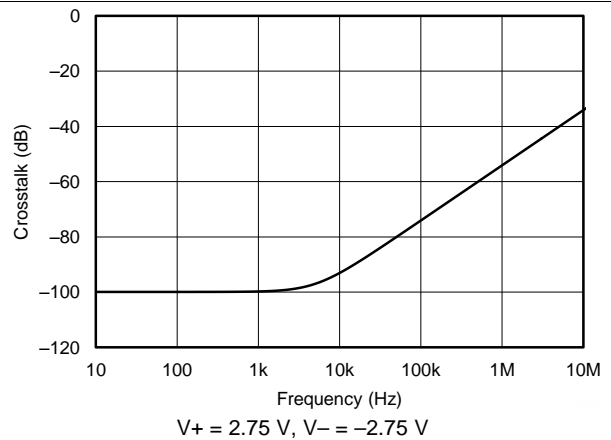

**图 36. Channel Separation vs Frequency**

## 7 Detailed Description

### 7.1 Overview

The OPAX316-Q1 is a family of low-power, rail-to-rail input and output operational amplifiers. These devices operate from 1.8 V to 5.5 V, are unity-gain stable, and are suitable for a wide range of general-purpose applications. The class AB output stage is capable of driving less than or equal to 10-k $\Omega$  loads connected to any point between V+ and ground. The input common-mode voltage range includes both rails and allows the OPAX316-Q1 series to be used in virtually any single-supply application. Rail-to-rail input and output swing significantly increases dynamic range, especially in low-supply applications, and makes them suitable for driving sampling analog-to-digital converters (ADCs).

The OPAX316-Q1 family features 10-MHz bandwidth and 6-V/ $\mu$ s slew rate with only 400- $\mu$ A supply current per channel, providing good ac performance at very-low-power consumption. DC applications are well served with a very-low input noise voltage of 11 nV/ $\sqrt{\text{Hz}}$  at 1 kHz, low input bias current (5 pA), and a typical input offset voltage of 0.5-mV.

### 7.2 Functional Block Diagram

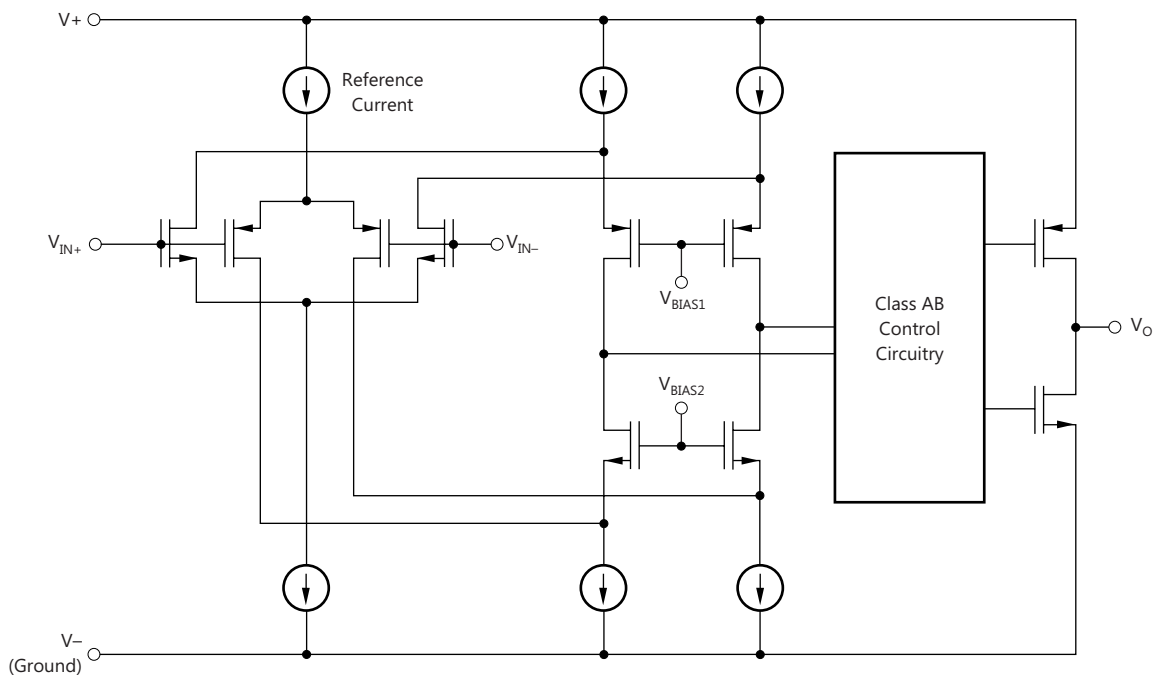

Copyright © 2017, Texas Instruments Incorporated

### 7.3 Feature Description

#### 7.3.1 Operating Voltage

The OPAX316-Q1 operational amplifiers are fully specified and ensured for operation from 1.8 V to 5.5 V. In addition, many specifications apply from  $-40^{\circ}\text{C}$  to  $+125^{\circ}\text{C}$ . Parameters that vary significantly with operating voltages or temperature are illustrated in the [Typical Characteristics](#) graphs.

## Feature Description (continued)

### 7.3.2 Rail-to-Rail Input

The input common-mode voltage range of the OPAx316-Q1 series extends 200 mV beyond the supply rails for supply voltages greater than 2.5 V. This performance is achieved with a complementary input stage: an N-channel input differential pair in parallel with a P-channel differential pair, as shown in the [Functional Block Diagram](#). The N-channel pair is active for input voltages close to the positive rail, typically  $(V+) - 1.4$  V to 200 mV above the positive supply, whereas the P-channel pair is active for inputs from 200 mV below the negative supply to approximately  $(V+) - 1.4$  V. There is a small transition region, typically  $(V+) - 1.2$  V to  $(V+) - 1$  V, in which both pairs are on. This 200-mV transition region can vary up to 200 mV with process variation. Thus, the transition region (both stages on) can range from  $(V+) - 1.4$  V to  $(V+) - 1.2$  V on the low end, up to  $(V+) - 1$  V to  $(V+) - 0.8$  V on the high end. Within this transition region, PSRR, CMRR, offset voltage, offset drift, and THD can degrade compared to device operation outside this region.

### 7.3.3 Input and ESD Protection

The OPAx316-Q1 incorporates internal ESD protection circuits on all pins. In the case of input and output pins, this protection primarily consists of current-steering diodes connected between the input and power-supply pins. These ESD protection diodes provide in-circuit, input overdrive protection, as long as the current is limited to 10 mA, as stated in [Absolute Maximum Ratings](#) table. [Figure 37](#) shows how a series input resistor can be added to the driven input to limit the input current. The added resistor contributes thermal noise at the amplifier input and the value must be kept to a minimum in noise-sensitive applications.

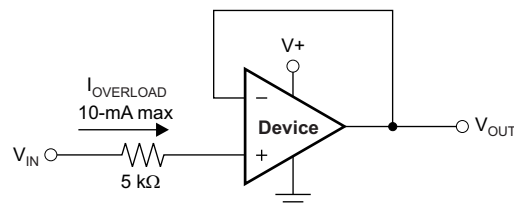

**Figure 37. Input Current Protection**

### 7.3.4 Common-Mode Rejection Ratio (CMRR)

CMRR for the OPAx316-Q1 is specified in several ways so the user can select the best match for a given application, as shown in the [Electrical Characteristics](#) table. First, the data sheet gives the CMRR of the device in the common-mode range below the transition region [ $V_{CM} < (V+) - 1.4$  V]. This specification is the best indicator of device capability when the application requires use of one of the differential input pairs. Second, the CMRR over the entire common-mode range is specified at  $V_{CM} = -0.2$  V to 5.7 V for  $V_S = 5.5$  V. This last value includes the variations shown in [Figure 4](#) through the transition region.

### 7.3.5 EMI Susceptibility and Input Filtering

Operational amplifiers vary with regard to the susceptibility of the device to electromagnetic interference (EMI). If conducted EMI enters the operational amplifier, the dc offset observed at the amplifier output can shift from the nominal value when EMI is present. This shift is a result of signal rectification associated with the internal semiconductor junctions. Although EMI can affect all operational amplifier pin functions, the signal input pins are likely to be the most susceptible. The OPA316-Q1 operational amplifier family incorporates an internal input low-pass filter that reduces the amplifier response to EMI. This filter provides both common-mode and differential-mode filtering. The filter is designed for a cutoff frequency of approximately 80 MHz (–3 dB), with a roll-off of 20 dB per decade.

TI developed the ability to accurately measure and quantify the immunity of an operational amplifier over a broad frequency spectrum extending from 10 MHz to 6 GHz. The EMI rejection ratio (EMIRR) metric allows operational amplifiers to be directly compared by the EMI immunity. [Figure 35](#) illustrates the testing results on the OPAx316-Q1. For more information, see [EMI Rejection Ratio of Operational Amplifiers](#).

## Feature Description (continued)

### 7.3.6 Rail-to-Rail Output

Designed as a low-power, low-noise operational amplifier, the OPAx316-Q1 delivers a robust output drive capability. A class AB output stage with common-source transistors achieves full rail-to-rail output swing capability. For resistive loads of 10-k $\Omega$ , the output swings typically to within 30 mV of either supply rail regardless of the power-supply voltage applied. Different load conditions change the ability of the amplifier to swing close to the rails; see [Figure 11](#).

### 7.3.7 Capacitive Load and Stability

The OPAx316-Q1 is designed for applications where driving a capacitive load is required. As with all operational amplifiers, there may be specific instances where the OPAx316-Q1 can become unstable. The particular operational amplifier circuit configuration, layout, gain, and output loading are some of the factors to consider when establishing whether or not an amplifier is stable in operation. An operational amplifier in the unity-gain (1 V/V) buffer configuration that drives a capacitive load exhibits a greater tendency to be unstable than an amplifier operated at a higher noise gain. The capacitive load, in conjunction with the operational amplifier output resistance, creates a pole within the feedback loop that degrades the phase margin. The degradation of the phase margin increases as the capacitive loading increases. As a conservative best practice, designing for 25% overshoot (40° phase margin) provides improved stability over process variations. The equivalent series resistance (ESR) of some very-large capacitors ( $C_L$  with a value greater than 1  $\mu$ F) is sufficient to alter the phase characteristics in the feedback loop such that the amplifier remains stable. Increasing the amplifier closed-loop gain allows the amplifier to drive increasingly larger capacitance. This increased capability is evident when observing the overshoot response of the amplifier at higher voltage gains. See [Figure 24](#) ( $G = -1$  V/V) and [Figure 25](#) ( $G = 1$  V/V).

Inserting a small resistor (typically 10- $\Omega$  to 20- $\Omega$ ) can increase the capacitive load capability of the amplifier in a unity-gain configuration, as shown in [Figure 38](#). This resistor significantly reduces the overshoot and ringing associated with large capacitive loads. One possible problem with this technique, however, is that a voltage divider is created with the added series resistor and any resistor connected in parallel with the capacitive load. The voltage divider introduces a gain error at the output that reduces the output swing.

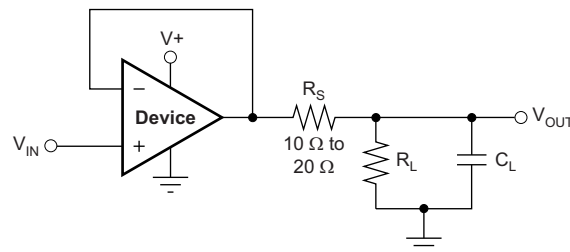

**Figure 38. Improving Capacitive Load Drive**

### 7.3.8 Overload Recovery

Overload recovery is defined as the time required for the operational amplifier output to recover from a saturated state to a linear state. The output devices of the operational amplifier enter a saturation region when the output voltage exceeds the rated operating voltage, either because of the high input voltage or the high gain. After the device enters the saturation region, the charge carriers in the output devices require time to return back to the linear state. After the charge carriers return back to the linear state, the device begins to slew at the specified slew rate. Thus, the propagation delay in case of an overload condition is the sum of the overload recovery time and the slew time. The overload recovery time for the OPAx316-Q1 is approximately 300 ns.

## 7.4 Device Functional Modes

The OPAx316-Q1 devices are powered on when the supply is connected. The devices can operate as a single-supply operational amplifier or a dual-supply amplifier, depending on the application.

## 8 Application and Implementation

### 注

Information in the following applications sections is not part of the TI component specification, and TI does not warrant its accuracy or completeness. TI's customers are responsible for determining suitability of components for their purposes. Customers should validate and test their design implementation to confirm system functionality.

### 8.1 Application Information

#### 8.1.1 General Configurations

When receiving low-level signals, the device often requires limiting the bandwidth of the incoming signals into the system. The simplest way to establish this limited bandwidth is to place an RC filter at the noninverting pin of the amplifier, as [Figure 39](#) shows.

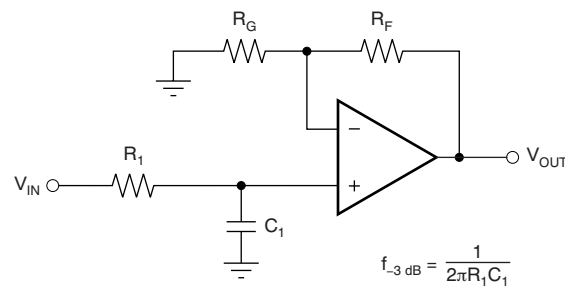

$$\frac{V_{OUT}}{V_{IN}} = \left(1 + \frac{R_F}{R_G}\right) \left(\frac{1}{1 + sR_1C_1}\right)$$

**Figure 39. Single-Pole Low-Pass Filter**

If even more attenuation is needed, the device requires a multiple-pole filter. The Sallen-Key filter can be used for this task, as [Figure 40](#) shows. For best results, the amplifier must have a bandwidth that is eight to 10 times the filter frequency bandwidth. Failure to follow this guideline can result in phase shift of the amplifier.

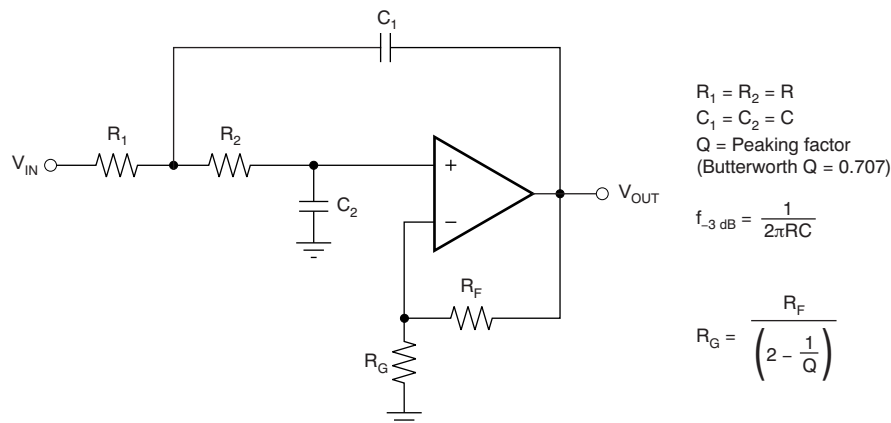

**Figure 40. Two-Pole, Low-Pass, Sallen-Key Filter**

## 8.2 Typical Application

Some applications require differential signals. [Figure 41](#) shows a simple circuit to convert a single-ended input of 0.1 V to 2.4 V into a differential output of  $\pm 2.3$  V on a single 2.7-V supply. The output range is intentionally limited to maximize linearity. The circuit is composed of two amplifiers. One amplifier functions as a buffer and creates a voltage ( $V_{OUT+}$ ). The second amplifier inverts the input and adds a reference voltage to generate  $V_{OUT-}$ .  $V_{OUT+}$  and  $V_{OUT-}$  range from 0.1 V to 2.4 V. The difference ( $V_{DIFF}$ ) is the difference between  $V_{OUT+}$  and  $V_{OUT-}$ , resulting in a differential output voltage range of 2.3 V.

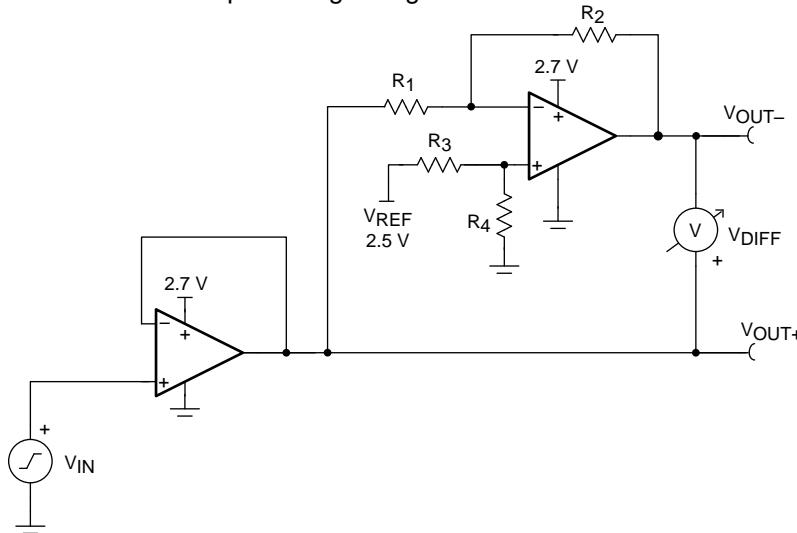

**Figure 41. Schematic for a Single-Ended Input to Differential Output Conversion**

### 8.2.1 Design Requirements

[Table 1](#) lists the design requirements:

**Table 1. Design Parameters**

| DESIGN PARAMETER            | VALUE          |
|-----------------------------|----------------|
| Supply voltage              | 2.7 V          |
| Reference voltage           | 2.5 V          |
| Input voltage               | 0.1 V to 2.4 V |
| Output differential voltage | $\pm 2.3$ V    |
| Output common-mode voltage  | 1.25 V         |
| Small-signal bandwidth      | 5 MHz          |

### 8.2.2 Detailed Design Procedure

The circuit in [Figure 41](#) takes a single-ended input signal ( $V_{IN}$ ) and generates two output signals ( $V_{OUT+}$  and  $V_{OUT-}$ ) using two amplifiers and a reference voltage ( $V_{REF}$ ).  $V_{OUT+}$  is the output of the first amplifier and is a buffered version of the input signal ( $V_{IN}$ ), as shown in [Equation 1](#).  $V_{OUT-}$  is the output of the second amplifier that uses  $V_{REF}$  to add an offset voltage to  $V_{IN}$  and feedback to add inverting gain. The transfer function for  $V_{OUT-}$  is given in [Equation 2](#).

$$V_{OUT+} = V_{IN} \quad (1)$$

$$V_{OUT-} = V_{REF} \times \left( \frac{R_4}{R_3 + R_4} \right) \times \left( 1 + \frac{R_2}{R_1} \right) - V_{IN} \times \frac{R_2}{R_1} \quad (2)$$

The differential output signal ( $V_{DIFF}$ ) is the difference between the two single-ended output signals ( $V_{OUT+}$  and  $V_{OUT-}$ ). [Equation 3](#) shows the transfer function for  $V_{DIFF}$ . Using conditions in [Equation 4](#) and [Equation 5](#) and applying the conditions that  $R_1 = R_2$  and  $R_3 = R_4$ , the transfer function is simplified into [Equation 6](#). Using this configuration, the maximum input signal is equal to the reference voltage, and the maximum output of each amplifier is equal to  $V_{REF}$ . The differential output range is  $2 \times V_{REF}$ . Furthermore, the common-mode voltage is one half of  $V_{REF}$ , as shown in [Equation 7](#).

$$V_{\text{DIFF}} = V_{\text{OUT}+} - V_{\text{OUT}-} = V_{\text{IN}} \times \left(1 + \frac{R_2}{R_1}\right) - V_{\text{REF}} \times \left(\frac{R_4}{R_3 + R_4}\right) \times \left(1 + \frac{R_2}{R_1}\right) \quad (3)$$

$$V_{\text{OUT}+} = V_{\text{IN}} \quad (4)$$

$$V_{\text{OUT}-} = V_{\text{REF}} - V_{\text{IN}} \quad (5)$$

$$V_{\text{DIFF}} = 2 \times V_{\text{IN}} - V_{\text{REF}} \quad (6)$$

$$V_{\text{CM}} = \left(\frac{V_{\text{OUT}+} + V_{\text{OUT}-}}{2}\right) = \frac{1}{2} V_{\text{REF}} \quad (7)$$

### 8.2.2.1 Amplifier Selection

Linearity over the input range is key for good dc accuracy. The common-mode input range and output swing limitations determine the linearity. In general, an amplifier with rail-to-rail input and output swing is required. Bandwidth is a key concern for this design, so the OPAx316-Q1 is selected because the bandwidth is greater than the target of 5 MHz. The bandwidth and power ratio makes this device power efficient and the low offset and drift ensure good accuracy for moderate precision applications.

### 8.2.2.2 Passive Component Selection

Because the transfer function of  $V_{\text{OUT}-}$  is heavily reliant on resistors ( $R_1$ ,  $R_2$ ,  $R_3$ , and  $R_4$ ), use resistors with low tolerances to maximize performance and minimize error. This design uses resistors with resistance values of 49.9-k $\Omega$  and tolerances of 0.1%. However, if the noise of the system is a key parameter, smaller resistance values (6-k $\Omega$  or lower) can be selected to keep the overall system noise low. This ensures that the noise from the resistors is lower than the amplifier noise.

### 8.2.3 Application Curves

The measured transfer functions in [Figure 42](#), [Figure 43](#), and [Figure 44](#) are generated by sweeping the input voltage from 0.1 V to 2.4 V. The full input range is actually 0 V to 2.5 V, but is restricted to 0.1 V to maintain optimal linearity. For more details on this design and other alternative devices that can be used in place of the OPAx316-Q1, see [Single-Ended Input to Differential Output Conversion Circuit Reference Design](#).

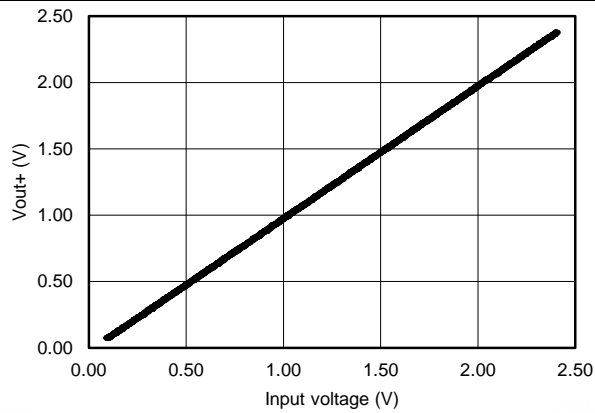

Figure 42.  $V_{OUT+}$  vs Input Voltage

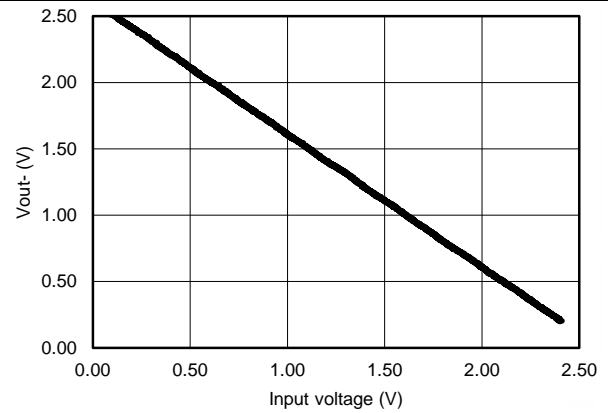

Figure 43.  $V_{OUT-}$  vs Input Voltage

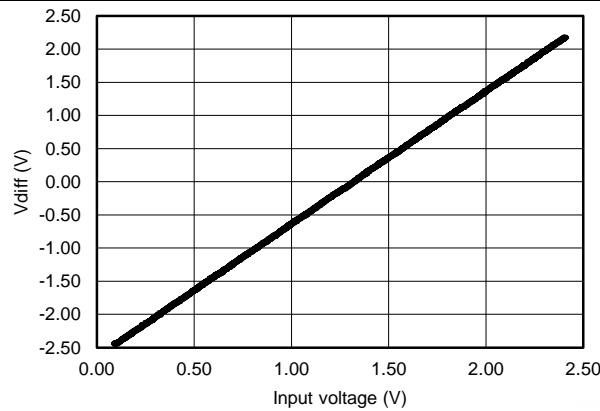

Figure 44.  $V_{DIFF}$  vs Input Voltage

## 9 Power Supply Recommendations

The OPAx316-Q1 family is specified for operation from 1.8 V to 5.5 V ( $\pm 0.9$  V to  $\pm 2.75$  V); many specifications apply from  $-40^{\circ}\text{C}$  to  $+125^{\circ}\text{C}$ . The [Typical Characteristics](#) section presents parameters that can exhibit significant variance with regard to operating voltage or temperature.

### 注意

Supply voltages larger than 7 V can permanently damage the device; see the [Absolute Maximum Ratings](#) table.

Place 0.1- $\mu\text{F}$  bypass capacitors close to the power-supply pins to reduce errors coupling in from noisy or high-impedance power supplies. For more information on bypass capacitor placement, see the [Layout Guidelines](#) section.

## 10 Layout

### 10.1 Layout Guidelines

For best operational performance of the device, use good PCB layout practices, including:

- Noise can propagate into analog circuitry through the power pins of the circuit as a whole and the operational amplifier. Bypass capacitors reduce the coupled noise by providing low-impedance power sources local to the analog circuitry.
  - Connect low-ESR, 0.1- $\mu$ F ceramic bypass capacitors between each supply pin and ground, placed as close to the device as possible. A single bypass capacitor from V+ to ground is applicable for single-supply applications.
- Separate grounding for analog and digital portions of the circuitry is one of the simplest and most effective methods of noise suppression. One or more layers on multilayer PCBs are typically devoted to ground planes. A ground plane helps distribute heat and reduces EMI noise pickup. Take care to physically separate digital and analog grounds, paying attention to the flow of the ground current.
- To reduce parasitic coupling, run the input traces as far away from the supply or output traces as possible. If these traces cannot be kept separate, crossing the sensitive trace perpendicularly is much better than crossing in parallel with the noisy trace.
- Place the external components as close to the device as possible. Keeping  $R_F$  and  $R_G$  close to the inverting input minimizes parasitic capacitance, as shown in [Figure 45](#).
- Keep the length of input traces as short as possible. Remember that the input traces are the most sensitive part of the circuit.
- Consider a driven, low-impedance guard ring around the critical traces. A guard ring can significantly reduce leakage currents from nearby traces that are at different potentials.

### 10.2 Layout Example

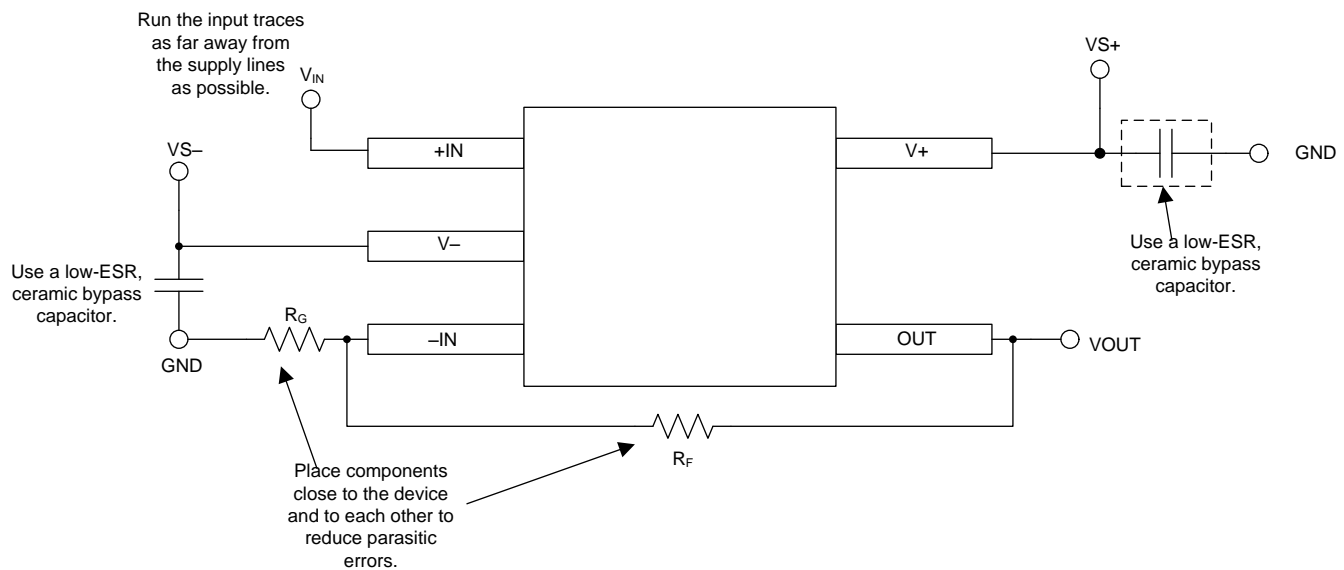

Copyright © 2016, Texas Instruments Incorporated

**Figure 45. Operational Amplifier Board Layout for Noninverting Configuration**

## 11 デバイスおよびドキュメントのサポート

### 11.1 ドキュメントのサポート

#### 11.1.1 関連資料

関連資料については、以下を参照してください:

- 『[オペアンプのEMI除去比](#)』
- 『[シングル・エンド入力から差動出力への変換回路のリファレンス・デザイン](#)』

#### 11.2 関連リンク

表 2 に、クイック・アクセス・リンクの一覧を示します。カテゴリには、技術資料、サポートおよびコミュニティ・リソース、ツールとソフトウェア、およびサンプル注文またはご購入へのクイック・アクセスが含まれます。

表 2. 関連リンク

| 製品         | プロダクト・フォルダ              | サンプルとご購入                | 技術資料                    | ツールとソフトウェア              | サポートとコミュニティ             |
|------------|-------------------------|-------------------------|-------------------------|-------------------------|-------------------------|
| OPA316-Q1  | <a href="#">ここをクリック</a> | <a href="#">ここをクリック</a> | <a href="#">ここをクリック</a> | <a href="#">ここをクリック</a> | <a href="#">ここをクリック</a> |
| OPA2316-Q1 | <a href="#">ここをクリック</a> | <a href="#">ここをクリック</a> | <a href="#">ここをクリック</a> | <a href="#">ここをクリック</a> | <a href="#">ここをクリック</a> |
| OPA4316-Q1 | <a href="#">ここをクリック</a> | <a href="#">ここをクリック</a> | <a href="#">ここをクリック</a> | <a href="#">ここをクリック</a> | <a href="#">ここをクリック</a> |

#### 11.3 ドキュメントの更新通知を受け取る方法

ドキュメントの更新についての通知を受け取るには、[ti.com](#)のデバイス製品フォルダを開いてください。右上の隅にある「通知を受け取る」をクリックして登録すると、変更されたすべての製品情報に関するダイジェストを毎週受け取れます。変更の詳細については、修正されたドキュメントに含まれている改訂履歴をご覧ください。

#### 11.4 コミュニティ・リソース

The following links connect to TI community resources. Linked contents are provided "AS IS" by the respective contributors. They do not constitute TI specifications and do not necessarily reflect TI's views; see TI's [Terms of Use](#).

**TI E2E™オンライン・コミュニティ** *TIのE2E ( Engineer-to-Engineer )* コミュニティ。エンジニア間の共同作業を促進するために開設されたものです。e2e.ti.comでは、他のエンジニアに質問し、知識を共有し、アイデアを検討して、問題解決に役立てることが出来ます。

**設計サポート** *TIの設計サポート* 役に立つE2Eフォーラムや、設計サポート・ツールをすばやく見つけることができます。技術サポート用の連絡先情報も参照できます。

#### 11.5 商標

E2E is a trademark of Texas Instruments.

#### 11.6 静電気放電に関する注意事項



これらのデバイスは、限定的なESD(静電破壊)保護機能を内蔵しています。保存時または取り扱い時は、MOSゲートに対する静電破壊を防止するために、リード線同士をショートさせておくか、デバイスを導電フォームに入れる必要があります。

#### 11.7 Glossary

**SLYZ022** — *TI Glossary*.

This glossary lists and explains terms, acronyms, and definitions.

## 12 メカニカル、パッケージ、および注文情報

以降のページには、メカニカル、パッケージ、および注文に関する情報が記載されています。この情報は、そのデバイスについて利用可能な最新のデータです。このデータは予告なく変更されることがあり、ドキュメントが改訂される場合もあります。本データシートのブラウザ版を使用されている場合は、画面左側の説明をご覧ください。

**PACKAGING INFORMATION**

| Orderable part number           | Status<br>(1) | Material type<br>(2) | Package   Pins   | Package qty   Carrier | RoHS<br>(3) | Lead finish/<br>Ball material<br>(4) | MSL rating/<br>Peak reflow<br>(5) | Op temp (°C) | Part marking<br>(6) |
|---------------------------------|---------------|----------------------|------------------|-----------------------|-------------|--------------------------------------|-----------------------------------|--------------|---------------------|
| <a href="#">OPA2316QDQKQ1</a>   | Active        | Production           | VSSOP (DGK)   8  | 80   TUBE             | Yes         | NIPDAUAG                             | Level-2-260C-1 YEAR               | -40 to 125   | 15E6                |
| OPA2316QDQKQ1.B                 | Active        | Production           | VSSOP (DGK)   8  | 80   TUBE             | Yes         | NIPDAUAG                             | Level-2-260C-1 YEAR               | -40 to 125   | 15E6                |
| <a href="#">OPA2316QDQKQRQ1</a> | Active        | Production           | VSSOP (DGK)   8  | 2500   LARGE T&R      | Yes         | NIPDAU   NIPDAUAG                    | Level-2-260C-1 YEAR               | -40 to 125   | 15E6                |
| OPA2316QDQKQRQ1.B               | Active        | Production           | VSSOP (DGK)   8  | 2500   LARGE T&R      | Yes         | NIPDAUAG                             | Level-2-260C-1 YEAR               | -40 to 125   | 15E6                |
| <a href="#">OPA316QDBVRQ1</a>   | Active        | Production           | SOT-23 (DBV)   5 | 3000   LARGE T&R      | Yes         | NIPDAU   SN                          | Level-2-260C-1 YEAR               | -40 to 125   | 15AD                |
| OPA316QDBVRQ1.B                 | Active        | Production           | SOT-23 (DBV)   5 | 3000   LARGE T&R      | Yes         | NIPDAU                               | Level-2-260C-1 YEAR               | -40 to 125   | 15AD                |
| <a href="#">OPA316QDBVTQ1</a>   | Active        | Production           | SOT-23 (DBV)   5 | 250   SMALL T&R       | Yes         | NIPDAU   SN                          | Level-2-260C-1 YEAR               | -40 to 125   | 15AD                |
| OPA316QDBVTQ1.B                 | Active        | Production           | SOT-23 (DBV)   5 | 250   SMALL T&R       | Yes         | NIPDAU                               | Level-2-260C-1 YEAR               | -40 to 125   | 15AD                |
| <a href="#">OPA4316QPWRQ1</a>   | Active        | Production           | TSSOP (PW)   14  | 2000   LARGE T&R      | Yes         | NIPDAU                               | Level-2-260C-1 YEAR               | -40 to 125   | 4316Q1              |
| OPA4316QPWRQ1.B                 | Active        | Production           | TSSOP (PW)   14  | 2000   LARGE T&R      | Yes         | NIPDAU                               | Level-2-260C-1 YEAR               | -40 to 125   | 4316Q1              |

(1) **Status:** For more details on status, see our [product life cycle](#).

(2) **Material type:** When designated, preproduction parts are prototypes/experimental devices, and are not yet approved or released for full production. Testing and final process, including without limitation quality assurance, reliability performance testing, and/or process qualification, may not yet be complete, and this item is subject to further changes or possible discontinuation. If available for ordering, purchases will be subject to an additional waiver at checkout, and are intended for early internal evaluation purposes only. These items are sold without warranties of any kind.

(3) **RoHS values:** Yes, No, RoHS Exempt. See the [TI RoHS Statement](#) for additional information and value definition.

(4) **Lead finish/Ball material:** Parts may have multiple material finish options. Finish options are separated by a vertical ruled line. Lead finish/Ball material values may wrap to two lines if the finish value exceeds the maximum column width.

(5) **MSL rating/Peak reflow:** The moisture sensitivity level ratings and peak solder (reflow) temperatures. In the event that a part has multiple moisture sensitivity ratings, only the lowest level per JEDEC standards is shown. Refer to the shipping label for the actual reflow temperature that will be used to mount the part to the printed circuit board.

(6) **Part marking:** There may be an additional marking, which relates to the logo, the lot trace code information, or the environmental category of the part.

Multiple part markings will be inside parentheses. Only one part marking contained in parentheses and separated by a "~" will appear on a part. If a line is indented then it is a continuation of the previous line and the two combined represent the entire part marking for that device.

**Important Information and Disclaimer:** The information provided on this page represents TI's knowledge and belief as of the date that it is provided. TI bases its knowledge and belief on information provided by third parties, and makes no representation or warranty as to the accuracy of such information. Efforts are underway to better integrate information from third parties. TI has taken and continues to take reasonable steps to provide representative

and accurate information but may not have conducted destructive testing or chemical analysis on incoming materials and chemicals. TI and TI suppliers consider certain information to be proprietary, and thus CAS numbers and other limited information may not be available for release.

In no event shall TI's liability arising out of such information exceed the total purchase price of the TI part(s) at issue in this document sold by TI to Customer on an annual basis.

**OTHER QUALIFIED VERSIONS OF OPA2316-Q1, OPA316-Q1, OPA4316-Q1 :**

- Catalog : [OPA2316](#), [OPA316](#), [OPA4316](#)

NOTE: Qualified Version Definitions:

- Catalog - TI's standard catalog product

**TAPE AND REEL INFORMATION**

**QUADRANT ASSIGNMENTS FOR PIN 1 ORIENTATION IN TAPE**

\*All dimensions are nominal

| Device         | Package Type | Package Drawing | Pins | SPQ  | Reel Diameter (mm) | Reel Width W1 (mm) | A0 (mm) | B0 (mm) | K0 (mm) | P1 (mm) | W (mm) | Pin1 Quadrant |
|----------------|--------------|-----------------|------|------|--------------------|--------------------|---------|---------|---------|---------|--------|---------------|
| OPA2316QDGKRQ1 | VSSOP        | DGK             | 8    | 2500 | 330.0              | 12.4               | 5.3     | 3.4     | 1.4     | 8.0     | 12.0   | Q1            |
| OPA2316QDGKRQ1 | VSSOP        | DGK             | 8    | 2500 | 330.0              | 12.4               | 5.3     | 3.4     | 1.4     | 8.0     | 12.0   | Q1            |
| OPA316QDBVRQ1  | SOT-23       | DBV             | 5    | 3000 | 180.0              | 8.4                | 3.2     | 3.2     | 1.4     | 4.0     | 8.0    | Q3            |
| OPA316QDBVRQ1  | SOT-23       | DBV             | 5    | 3000 | 178.0              | 9.0                | 3.3     | 3.2     | 1.4     | 4.0     | 8.0    | Q3            |
| OPA316QDBVTQ1  | SOT-23       | DBV             | 5    | 250  | 178.0              | 9.0                | 3.23    | 3.17    | 1.37    | 4.0     | 8.0    | Q3            |
| OPA316QDBVTQ1  | SOT-23       | DBV             | 5    | 250  | 180.0              | 8.4                | 3.2     | 3.2     | 1.4     | 4.0     | 8.0    | Q3            |
| OPA4316QPWRQ1  | TSSOP        | PW              | 14   | 2000 | 330.0              | 12.4               | 6.9     | 5.6     | 1.6     | 8.0     | 12.0   | Q1            |

**TAPE AND REEL BOX DIMENSIONS**

\*All dimensions are nominal

| Device         | Package Type | Package Drawing | Pins | SPQ  | Length (mm) | Width (mm) | Height (mm) |
|----------------|--------------|-----------------|------|------|-------------|------------|-------------|
| OPA2316QDGKRQ1 | VSSOP        | DGK             | 8    | 2500 | 353.0       | 353.0      | 32.0        |
| OPA2316QDGKRQ1 | VSSOP        | DGK             | 8    | 2500 | 366.0       | 364.0      | 50.0        |
| OPA316QDBVRQ1  | SOT-23       | DBV             | 5    | 3000 | 210.0       | 185.0      | 35.0        |
| OPA316QDBVRQ1  | SOT-23       | DBV             | 5    | 3000 | 180.0       | 180.0      | 18.0        |
| OPA316QDBVTQ1  | SOT-23       | DBV             | 5    | 250  | 180.0       | 180.0      | 18.0        |
| OPA316QDBVTQ1  | SOT-23       | DBV             | 5    | 250  | 210.0       | 185.0      | 35.0        |
| OPA4316QPWRQ1  | TSSOP        | PW              | 14   | 2000 | 353.0       | 353.0      | 32.0        |

**TUBE**

\*All dimensions are nominal

| Device          | Package Name | Package Type | Pins | SPQ | L (mm) | W (mm) | T (μm) | B (mm) |
|-----------------|--------------|--------------|------|-----|--------|--------|--------|--------|
| OPA2316QDQKQ1   | DGK          | VSSOP        | 8    | 80  | 330    | 6.55   | 500    | 2.88   |
| OPA2316QDQKQ1.B | DGK          | VSSOP        | 8    | 80  | 330    | 6.55   | 500    | 2.88   |



# EXAMPLE BOARD LAYOUT

DBV0005A

SOT-23 - 1.45 mm max height

SMALL OUTLINE TRANSISTOR



LAND PATTERN EXAMPLE  
EXPOSED METAL SHOWN  
SCALE:15X



SOLDER MASK DETAILS

4214839/K 08/2024

NOTES: (continued)

- 6. Publication IPC-7351 may have alternate designs.
- 7. Solder mask tolerances between and around signal pads can vary based on board fabrication site.

# EXAMPLE STENCIL DESIGN

DBV0005A

SOT-23 - 1.45 mm max height

SMALL OUTLINE TRANSISTOR



SOLDER PASTE EXAMPLE  
BASED ON 0.125 mm THICK STENCIL  
SCALE:15X

4214839/K 08/2024

NOTES: (continued)

8. Laser cutting apertures with trapezoidal walls and rounded corners may offer better paste release. IPC-7525 may have alternate design recommendations.
9. Board assembly site may have different recommendations for stencil design.

DGK0008A



# PACKAGE OUTLINE

VSSOP - 1.1 mm max height

SMALL OUTLINE PACKAGE



NOTES:

PowerPAD is a trademark of Texas Instruments.

1. All linear dimensions are in millimeters. Any dimensions in parenthesis are for reference only. Dimensioning and tolerancing per ASME Y14.5M.
2. This drawing is subject to change without notice.
3. This dimension does not include mold flash, protrusions, or gate burrs. Mold flash, protrusions, or gate burrs shall not exceed 0.15 mm per side.
4. This dimension does not include interlead flash. Interlead flash shall not exceed 0.25 mm per side.
5. Reference JEDEC registration MO-187.

# EXAMPLE BOARD LAYOUT

DGK0008A

™ VSSOP - 1.1 mm max height

SMALL OUTLINE PACKAGE



LAND PATTERN EXAMPLE  
EXPOSED METAL SHOWN  
SCALE: 15X



SOLDER MASK DETAILS

4214862/A 04/2023

NOTES: (continued)

6. Publication IPC-7351 may have alternate designs.
7. Solder mask tolerances between and around signal pads can vary based on board fabrication site.
8. Vias are optional depending on application, refer to device data sheet. If any vias are implemented, refer to their locations shown on this view. It is recommended that vias under paste be filled, plugged or tented.
9. Size of metal pad may vary due to creepage requirement.

# EXAMPLE STENCIL DESIGN

DGK0008A

™ VSSOP - 1.1 mm max height

SMALL OUTLINE PACKAGE



SOLDER PASTE EXAMPLE  
SCALE: 15X

4214862/A 04/2023

NOTES: (continued)

11. Laser cutting apertures with trapezoidal walls and rounded corners may offer better paste release. IPC-7525 may have alternate design recommendations.
12. Board assembly site may have different recommendations for stencil design.

PW0014A



**PACKAGE OUTLINE**  
**TSSOP - 1.2 mm max height**

SMALL OUTLINE PACKAGE



4220202/B 12/2023

**NOTES:**

1. All linear dimensions are in millimeters. Any dimensions in parenthesis are for reference only. Dimensioning and tolerancing per ASME Y14.5M.
2. This drawing is subject to change without notice.
3. This dimension does not include mold flash, protrusions, or gate burrs. Mold flash, protrusions, or gate burrs shall not exceed 0.15 mm per side.
4. This dimension does not include interlead flash. Interlead flash shall not exceed 0.25 mm per side.
5. Reference JEDEC registration MO-153.

# EXAMPLE BOARD LAYOUT

PW0014A

TSSOP - 1.2 mm max height

SMALL OUTLINE PACKAGE



LAND PATTERN EXAMPLE  
EXPOSED METAL SHOWN  
SCALE: 10X



4220202/B 12/2023

NOTES: (continued)

- 6. Publication IPC-7351 may have alternate designs.
- 7. Solder mask tolerances between and around signal pads can vary based on board fabrication site.

# EXAMPLE STENCIL DESIGN

PW0014A

TSSOP - 1.2 mm max height

SMALL OUTLINE PACKAGE



SOLDER PASTE EXAMPLE  
BASED ON 0.125 mm THICK STENCIL  
SCALE: 10X

4220202/B 12/2023

NOTES: (continued)

8. Laser cutting apertures with trapezoidal walls and rounded corners may offer better paste release. IPC-7525 may have alternate design recommendations.
9. Board assembly site may have different recommendations for stencil design.

## 重要なお知らせと免責事項

TI は、技術データと信頼性データ (データシートを含みます)、設計リソース (リファレンス デザインを含みます)、アプリケーションや設計に関する各種アドバイス、Web ツール、安全性情報、その他のリソースを、欠陥が存在する可能性のある「現状のまま」提供しており、商品性および特定目的に対する適合性の黙示保証、第三者の知的財産権の非侵害保証を含むいかなる保証も、明示的または黙示的にかかわらず拒否します。

これらのリソースは、TI 製品を使用する設計の経験を積んだ開発者への提供を意図したものです。(1) お客様のアプリケーションに適した TI 製品の選定、(2) お客様のアプリケーションの設計、検証、試験、(3) お客様のアプリケーションに該当する各種規格や、その他のあらゆる安全性、セキュリティ、規制、または他の要件への確実な適合に関する責任を、お客様のみが単独で負うものとし、

上記の各種リソースは、予告なく変更される可能性があります。これらのリソースは、リソースで説明されている TI 製品を使用するアプリケーションの開発の目的でのみ、TI はその使用をお客様に許諾します。これらのリソースに関して、他の目的で複製することや掲載することは禁止されています。TI や第三者の知的財産権のライセンスが付与されている訳ではありません。お客様は、これらのリソースを自身で使用した結果発生するあらゆる申し立て、損害、費用、損失、責任について、TI およびその代理人を完全に補償するものとし、TI は一切の責任を拒否します。

TI の製品は、[TI の販売条件](#)、[TI の総合的な品質ガイドライン](#)、[ti.com](#) または TI 製品などに関連して提供される他の適用条件に従い提供されます。TI がこれらのリソースを提供することは、適用される TI の保証または他の保証の放棄の拡大や変更を意味するものではありません。TI がカスタム、またはカスタマー仕様として明示的に指定していない限り、TI の製品は標準的なカタログに掲載される汎用機器です。

お客様がいかなる追加条項または代替条項を提案する場合も、TI はそれらに異議を唱え、拒否します。

Copyright © 2026, Texas Instruments Incorporated

最終更新日 : 2025 年 10 月