

OPA353
OPA2353
OPA4353

For most current data sheet and other product information, visit www.burr-brown.com

High-Speed, Single-Supply, Rail-to-Rail OPERATIONAL AMPLIFIERS

MicroAmplifier™ Series

FEATURES

- RAIL-TO-RAIL INPUT
- RAIL-TO-RAIL OUTPUT (within 10mV)
- WIDE BANDWIDTH: 44MHz
- HIGH SLEW RATE: 22V/μs
- LOW NOISE: 5nV/√Hz
- LOW THD+NOISE: 0.0006%
- UNITY-GAIN STABLE
- *MicroSIZE* PACKAGES
- SINGLE, DUAL, AND QUAD

APPLICATIONS

- CELL PHONE PA CONTROL LOOPS
- DRIVING A/D CONVERTERS
- VIDEO PROCESSING
- DATA ACQUISITION
- PROCESS CONTROL
- AUDIO PROCESSING
- COMMUNICATIONS
- ACTIVE FILTERS
- TEST EQUIPMENT

DESCRIPTION

OPA353 series rail-to-rail CMOS operational amplifiers are designed for low cost, miniature applications. They are optimized for low voltage, single-supply operation. Rail-to-rail input/output, low noise (5nV/√Hz), and high speed operation (44MHz, 22V/μs) make them ideal for driving sampling analog-to-digital converters. They are also well suited for cell phone PA control loops and video processing (75Ω drive capability) as well as audio and general purpose applications. Single, dual, and quad versions have identical specifications for design flexibility.

The OPA353 series operates on a single supply as low as 2.5V with an input common-mode voltage range that

extends 300mV beyond the supply rails. Output voltage swing is to within 10mV of the supply rails with a 10kΩ load. Dual and quad designs feature completely independent circuitry for lowest crosstalk and freedom from interaction.

The single (OPA353) packages are the tiny 5-lead SOT-23-5 surface mount and SO-8 surface mount. The dual (OPA2353) comes in the miniature MSOP-8 surface mount and SO-8 surface mount. The quad (OPA4353) packages are the space-saving SSOP-16 surface mount and SO-14 surface mount. All are specified from -40°C to +85°C and operate from -55°C to +125°C.

SPICE Model available at www.burr-brown.com

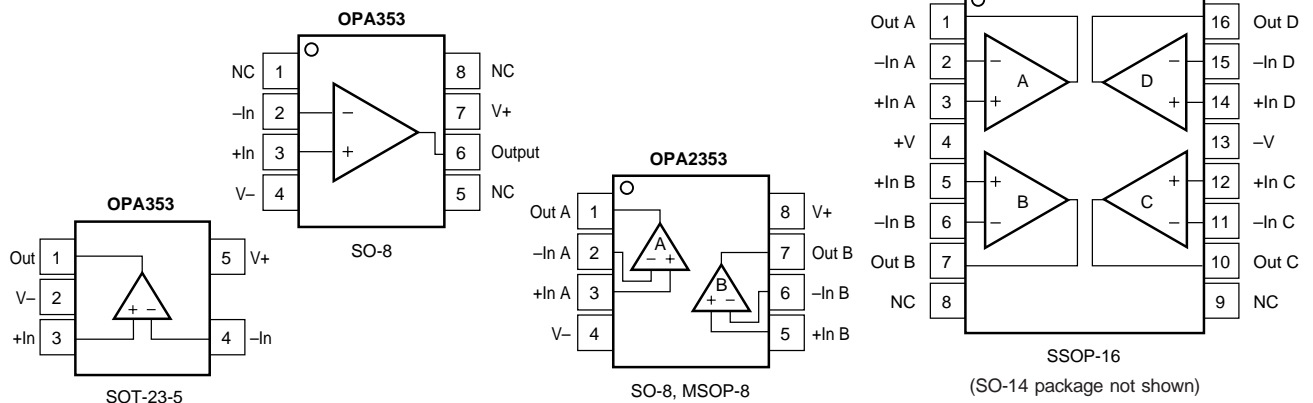

International Airport Industrial Park • Mailing Address: PO Box 11400, Tucson, AZ 85734 • Street Address: 6730 S. Tucson Blvd., Tucson, AZ 85706 • Tel: (520) 746-1111
Twx: 910-952-1111 • Internet: <http://www.burr-brown.com/> • Cable: BBRCORP • Telex: 066-6491 • FAX: (520) 889-1510 • Immediate Product Info: (800) 548-6132

SPECIFICATIONS: $V_S = 2.7V$ to $5.5V$

At $T_A = +25^\circ C$, $R_L = 1k\Omega$ connected to $V_S/2$ and $V_{OUT} = V_S/2$, unless otherwise noted.
Boldface limits apply over the specified temperature range, $T_A = -40^\circ C$ to $+85^\circ C$. $V_S = 5V$.

PARAMETER	CONDITION	OPA353NA, UA OPA2353EA, UA OPA4353EA, UA			UNITS
		MIN	TYP ⁽¹⁾	MAX	
OFFSET VOLTAGE Input Offset Voltage V_{OS} $T_A = -40^\circ C$ to $+85^\circ C$ vs Temperature vs Power Supply Rejection Ratio PSRR $T_A = -40^\circ C$ to $+85^\circ C$ Channel Separation (dual, quad)	$V_S = 5V$ $T_A = -40^\circ C$ to $+85^\circ C$ $V_S = 2.7V$ to $5.5V$, $V_{CM} = 0V$ $V_S = 2.7V$ to $5.5V$, $V_{CM} = 0V$ dc		± 3 ± 5 40 0.15	± 8 ± 10 150 175	mV mV $\mu V/^\circ C$ $\mu V/V$ $\mu V/V$
INPUT BIAS CURRENT Input Bias Current I_B $T_A = -40^\circ C$ to $+85^\circ C$ Input Offset Current I_{OS}			± 0.5 See Typical Curve ± 0.5	± 10 ± 10	pA pA
NOISE Input Voltage Noise, $f = 100Hz$ to $400kHz$ Input Voltage Noise Density, $f = 10kHz$ $f = 100kHz$ Current Noise Density, $f = 10kHz$			4 7 5 4		μV_{rms} nV/\sqrt{Hz} nV/\sqrt{Hz} fA/\sqrt{Hz}
INPUT VOLTAGE RANGE Common-Mode Voltage Range V_{CM} Common-Mode Rejection Ratio CMRR $T_A = -40^\circ C$ to $+85^\circ C$	$-0.1V < V_{CM} < (V+) - 2.4V$ $V_S = 5V$, $-0.1V < V_{CM} < 5.1V$ $V_S = 5V$, $-0.1V < V_{CM} < 5.1V$	-0.1 76 60 58	86 74	$(V+) + 0.1$	V dB dB dB
INPUT IMPEDANCE Differential Common-Mode			$10^{13} \parallel 2.5$ $10^{13} \parallel 6.5$		$\Omega \parallel pF$ $\Omega \parallel pF$
OPEN-LOOP GAIN Open-Loop Voltage Gain A_{OL} $T_A = -40^\circ C$ to $+85^\circ C$ $T_A = -40^\circ C$ to $+85^\circ C$	$R_L = 10k\Omega$, $50mV < V_O < (V+) - 50mV$ $R_L = 10k\Omega$, $50mV < V_O < (V+) - 50mV$ $R_L = 1k\Omega$, $200mV < V_O < (V+) - 200mV$ $R_L = 1k\Omega$, $200mV < V_O < (V+) - 200mV$	100 100 100 100	122 120		dB dB dB dB
FREQUENCY RESPONSE Gain-Bandwidth Product GBW Slew Rate SR Settling Time, 0.1% 0.01% Overload Recovery Time Total Harmonic Distortion + Noise THD+N Differential Gain Error Differential Phase Error	$C_L = 100pF$ $G = 1$ $G = 1$ $G = \pm 1$, 2V Step $G = \pm 1$, 2V Step $V_{IN} \cdot G = V_S$ $R_L = 600\Omega$, $V_O = 2.5V_{p-p}^{(2)}$, $G = 1$, $f = 1kHz$ $G = 2$, $R_L = 600\Omega$, $V_O = 1.4V^{(3)}$ $G = 2$, $R_L = 600\Omega$, $V_O = 1.4V^{(3)}$		44 22 0.22 0.5 0.1 0.0006 0.17 0.17		MHz V/ μs μs μs μs % % deg
OUTPUT Voltage Output Swing from Rail ⁽⁴⁾ V_{OUT} $T_A = -40^\circ C$ to $+85^\circ C$ $T_A = -40^\circ C$ to $+85^\circ C$ Output Current I_{OUT} Short-Circuit Current I_{SC} Capacitive Load Drive C_{LOAD}	$R_L = 10k\Omega$, $A_{OL} \geq 100dB$ $R_L = 10k\Omega$, $A_{OL} \geq 100dB$ $R_L = 1k\Omega$, $A_{OL} \geq 100dB$ $R_L = 1k\Omega$, $A_{OL} \geq 100dB$		10 25 $\pm 40^{(5)}$ ± 80	50 50 200 200	mV mV mV mV mA mA
POWER SUPPLY Operating Voltage Range V_S Minimum Operating Voltage Quiescent Current (per amplifier) I_Q $T_A = -40^\circ C$ to $+85^\circ C$	$T_A = -40^\circ C$ to $+85^\circ C$ $I_Q = 0$ $I_Q = 0$	2.7	2.5 5.2	5.5 8 9	V V mA mA
TEMPERATURE RANGE Specified Range Operating Range Storage Range Thermal Resistance θ_{JA} SOT-23-5 MSOP-8 Surface Mount SO-8 Surface Mount SSOP-16 Surface Mount SO-14 Surface Mount		-40 -55 -55		$+85$ $+125$ $+125$	$^\circ C$ $^\circ C$ $^\circ C$ $^\circ C/W$ $^\circ C/W$ $^\circ C/W$ $^\circ C/W$ $^\circ C/W$

NOTES: (1) $V_S = +5V$. (2) $V_{OUT} = 0.25V$ to $2.75V$. (3) NTSC signal generator used. See Figure 6 for test circuit. (4) Output voltage swings are measured between the output and power supply rails. (5) See typical performance curve, "Output Voltage Swing vs Output Swing."

PIN CONFIGURATION

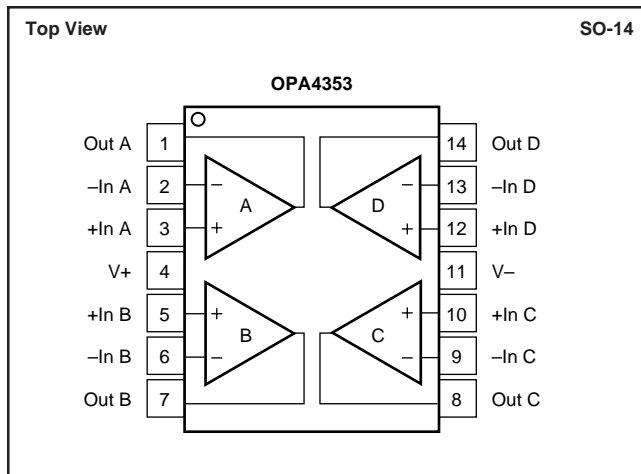

ELECTROSTATIC DISCHARGE SENSITIVITY

This integrated circuit can be damaged by ESD. Burr-Brown recommends that all integrated circuits be handled with appropriate precautions. Failure to observe proper handling and installation procedures can cause damage.

ESD damage can range from subtle performance degradation to complete device failure. Precision integrated circuits may be more susceptible to damage because very small parametric changes could cause the device not to meet its published specifications.

ABSOLUTE MAXIMUM RATINGS⁽¹⁾

Supply Voltage	5.5V
Signal Input Terminals, Voltage ⁽²⁾	(V-) - 0.3V to (V+) + 0.3V
Current ⁽²⁾	10mA
Output Short-Circuit ⁽³⁾	Continuous
Operating Temperature	-55°C to +125°C
Storage Temperature	-55°C to +125°C
Junction Temperature	150°C
Lead Temperature (soldering, 10s)	300°C

NOTES: (1) Stresses above these ratings may cause permanent damage. Exposure to absolute maximum conditions for extended periods may degrade device reliability. (2) Input terminals are diode-clamped to the power supply rails. Input signals that can swing more than 0.3V beyond the supply rails should be current-limited to 10mA or less. (3) Short circuit to ground, one amplifier per package.

PACKAGE/ORDERING INFORMATION

PRODUCT	PACKAGE	PACKAGE DRAWING NUMBER ⁽¹⁾	SPECIFIED TEMPERATURE RANGE	PACKAGE MARKING	ORDERING NUMBER ⁽²⁾	TRANSPORT MEDIA
Single						
OPA353NA	5-Lead SOT-23-5	331	-40°C to +85°C	D53	OPA353NA/250	Tape and Reel
"	"	"	"	"	OPA353NA/3K	Tape and Reel
OPA353UA	SO-8 Surface Mount	182	-40°C to +85°C	OPA353UA	OPA353UA	Rails
"	"	"	"	"	OPA353UA/2K5	Tape and Reel
Dual						
OPA2353EA	MSOP-8 Surface Mount	337	-40°C to +85°C	E53	OPA2353EA/250	Tape and Reel
"	"	"	"	"	OPA2353EA/2K5	Tape and Reel
OPA2353UA	SO-8 Surface Mount	182	-40°C to +85°C	OPA2353UA	OPA2353UA	Rails
"	"	"	"	"	OPA2353UA/2K5	Tape and Reel
Quad						
OPA4353EA	SSOP-16 Surface Mount	322	-40°C to +85°C	OPA4353EA	OPA4353EA/250	Tape and Reel
"	"	"	"	"	OPA4353EA/2K5	Tape and Reel
OPA4353UA	SO-14 Surface Mount	235	-40°C to +85°C	OPA4353UA	OPA4353UA	Rails
"	"	"	"	"	OPA4353UA/2K5	Tape and Reel

NOTES: (1) For detailed drawing and dimension table, please see end of data sheet, or Appendix C of Burr-Brown IC Data Book. (2) Models with a slash (/) are available only in Tape and Reel in the quantities indicated (e.g., /2K5 indicates 2500 devices per reel). Ordering 2500 pieces of "OPA2353EA/2K5" will get a single 2500-piece Tape and Reel. For detailed Tape and Reel mechanical information, refer to Appendix B of Burr-Brown IC Data Book.

The information provided herein is believed to be reliable; however, BURR-BROWN assumes no responsibility for inaccuracies or omissions. BURR-BROWN assumes no responsibility for the use of this information, and all use of such information shall be entirely at the user's own risk. Prices and specifications are subject to change without notice. No patent rights or licenses to any of the circuits described herein are implied or granted to any third party. BURR-BROWN does not authorize or warrant any BURR-BROWN product for use in life support devices and/or systems.

TYPICAL PERFORMANCE CURVES

At $T_A = +25^\circ\text{C}$, $V_S = +5\text{V}$, and $R_L = 1\text{k}\Omega$ connected to $V_S/2$, unless otherwise noted.

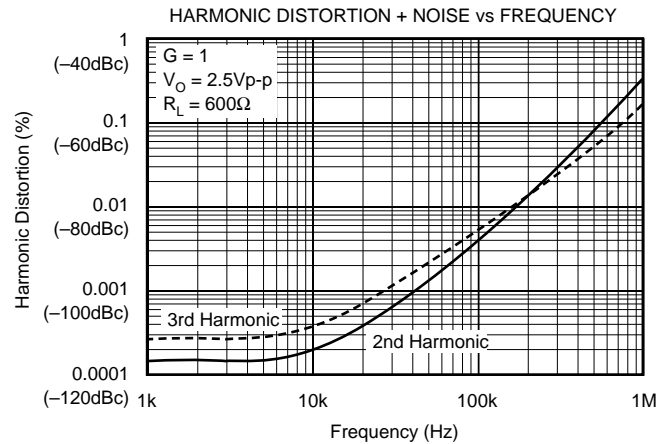
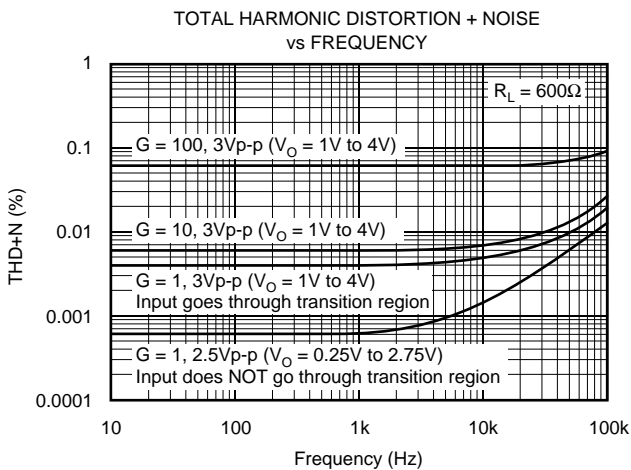
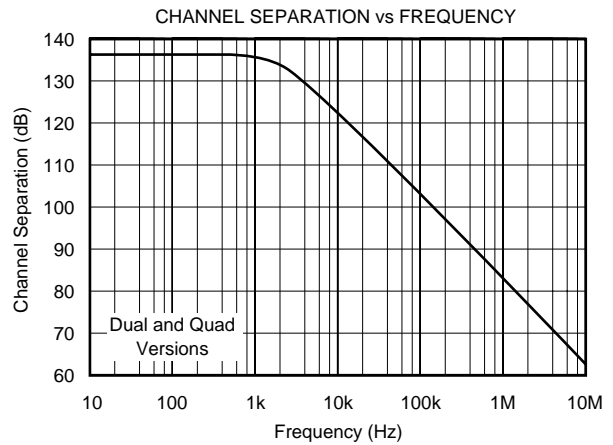
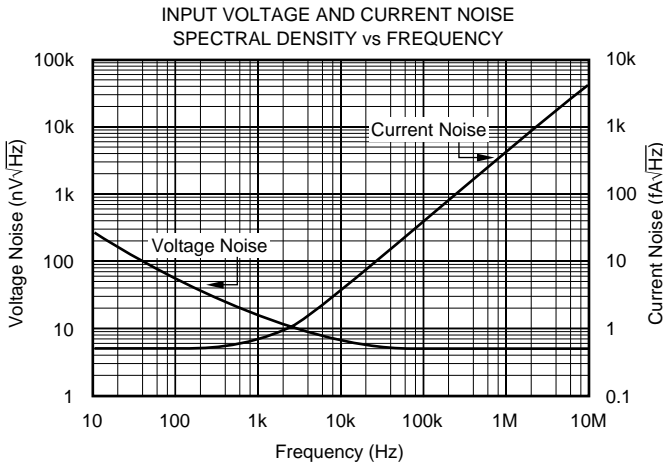
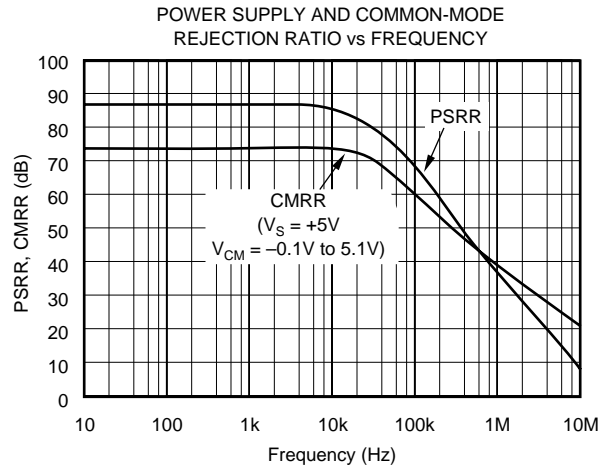
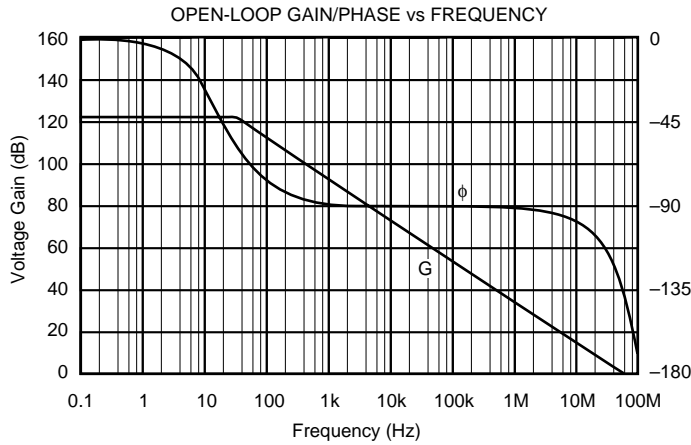

TYPICAL PERFORMANCE CURVES (CONT)

At $T_A = +25^\circ\text{C}$, $V_S = +5\text{V}$, and $R_L = 1\text{k}\Omega$ connected to $V_S/2$, unless otherwise noted.

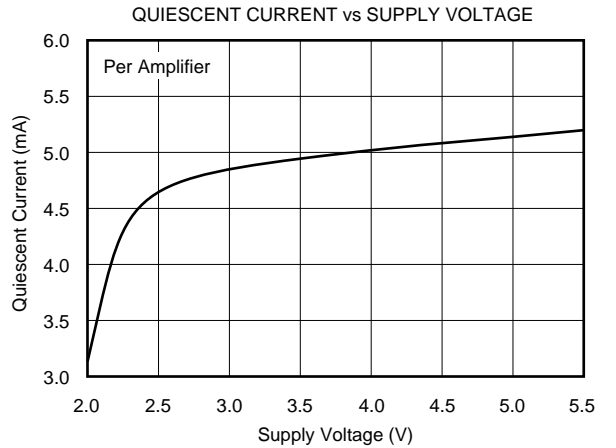
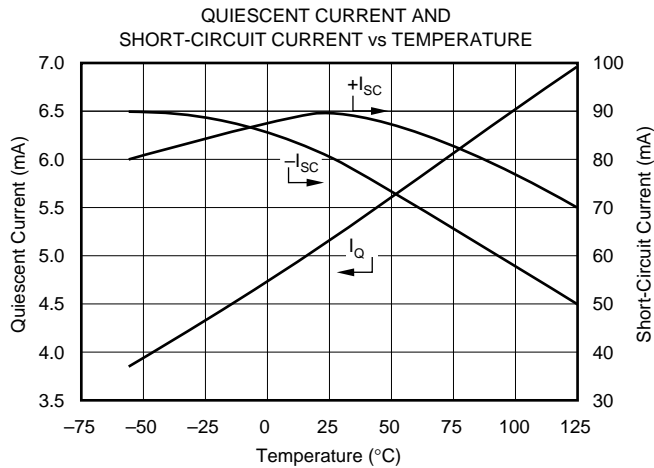
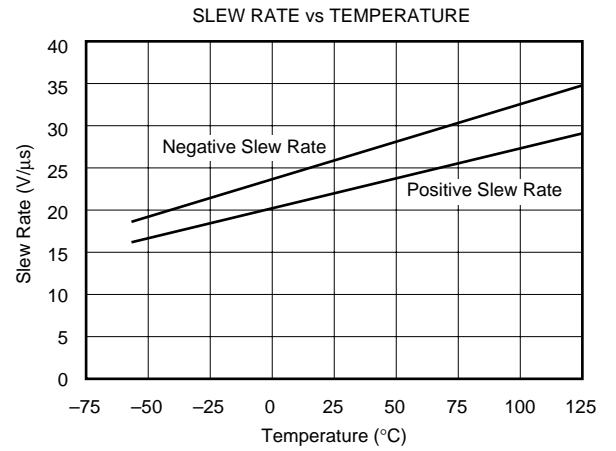
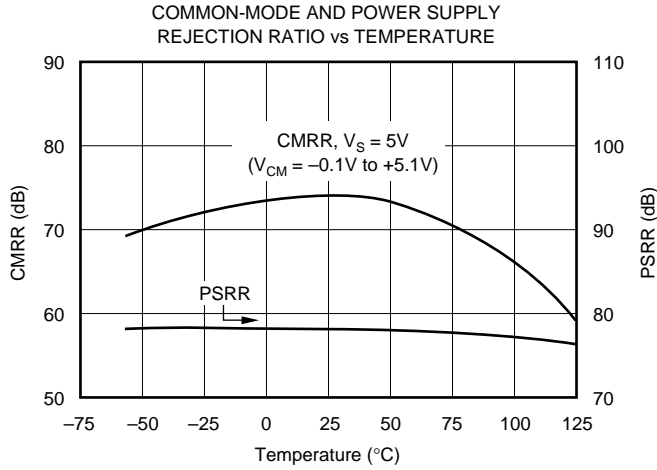
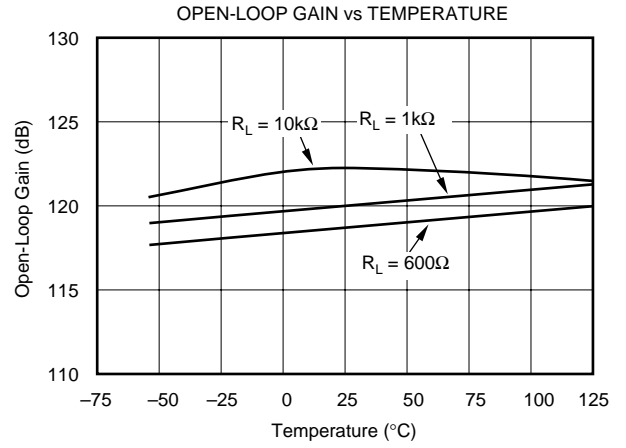
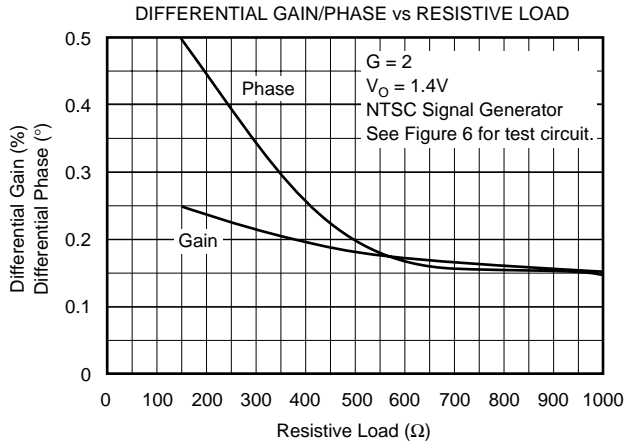

TYPICAL PERFORMANCE CURVES (CONT)

At $T_A = +25^\circ\text{C}$, $V_S = +5\text{V}$, and $R_L = 1\text{k}\Omega$ connected to $V_S/2$, unless otherwise noted.

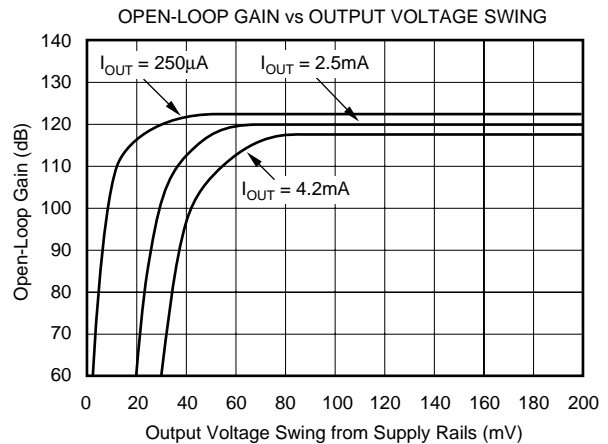
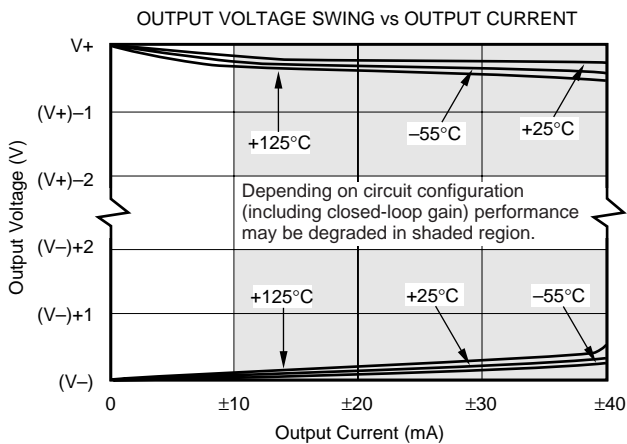
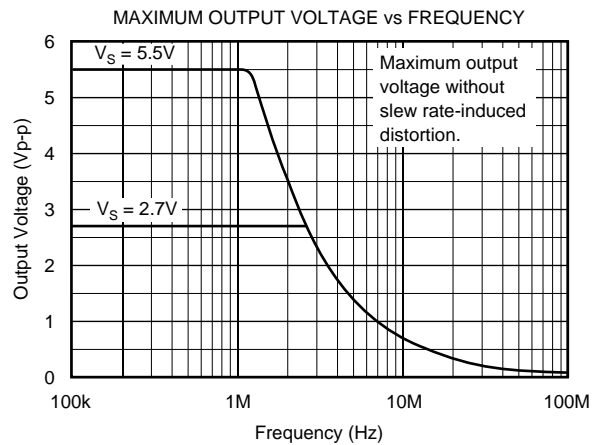
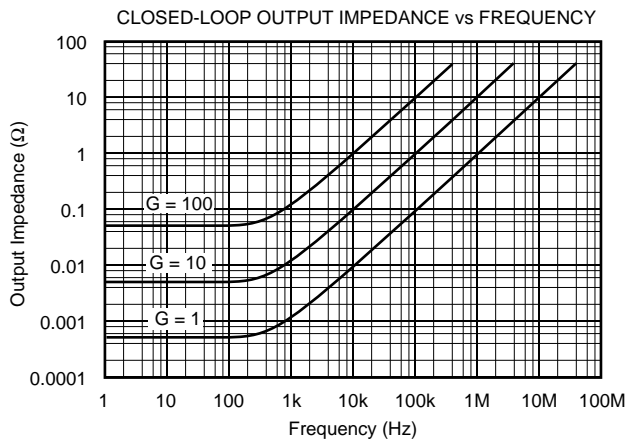
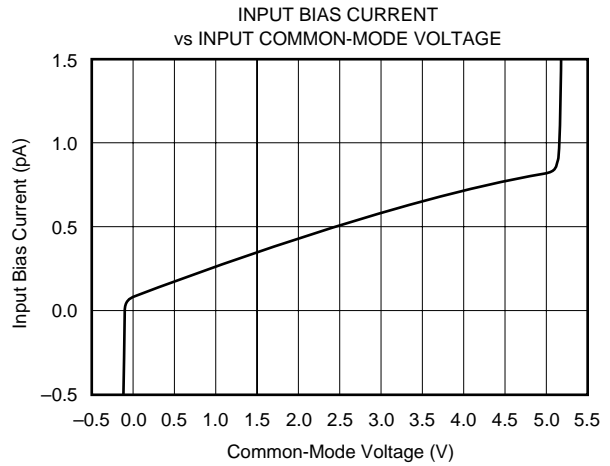
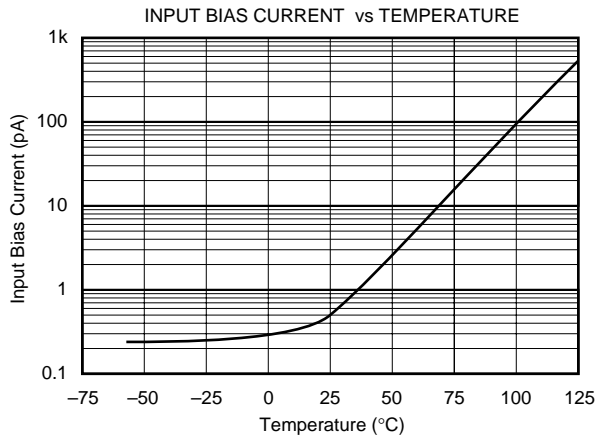

TYPICAL PERFORMANCE CURVES (CONT)

At $T_A = +25^\circ\text{C}$, $V_S = +5\text{V}$, and $R_L = 1\text{k}\Omega$ connected to $V_S/2$, unless otherwise noted.

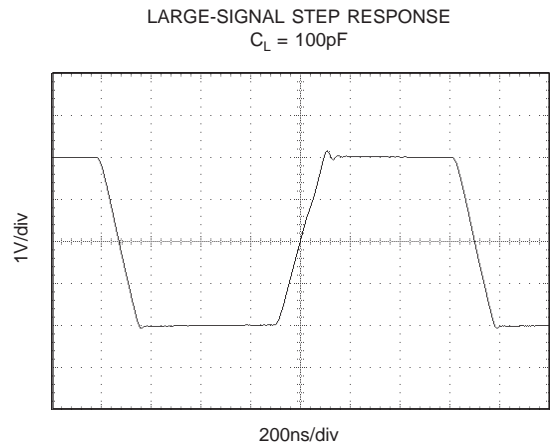
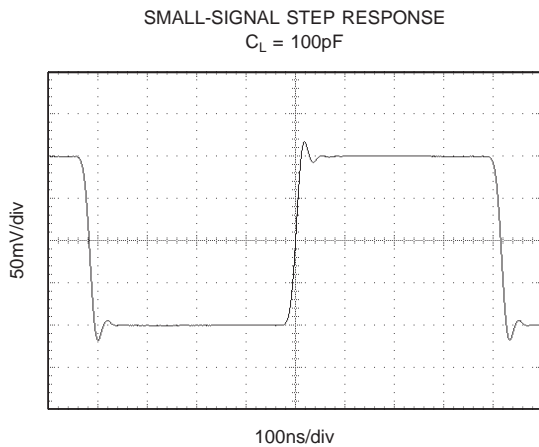
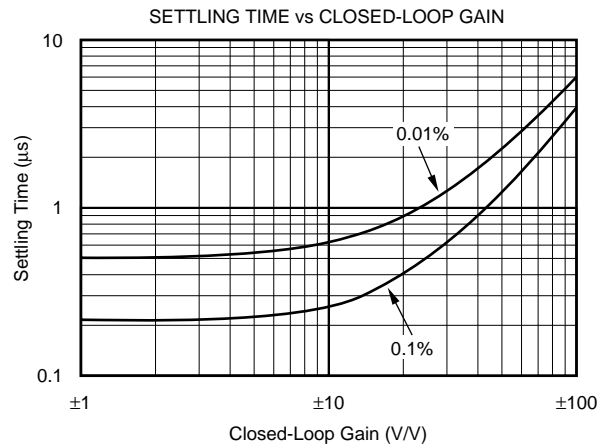
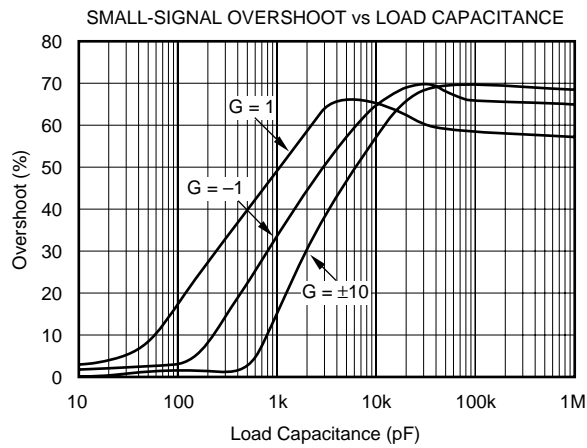
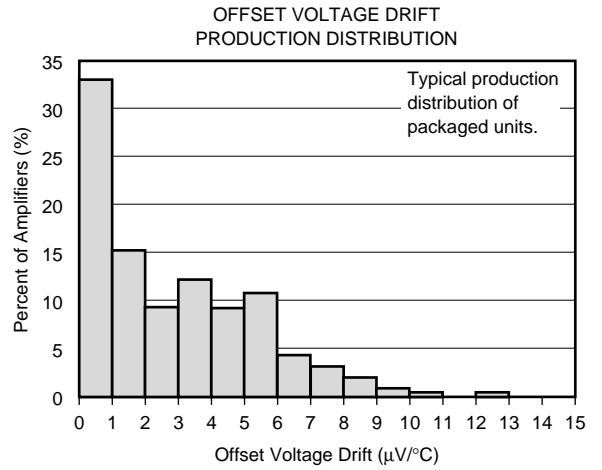
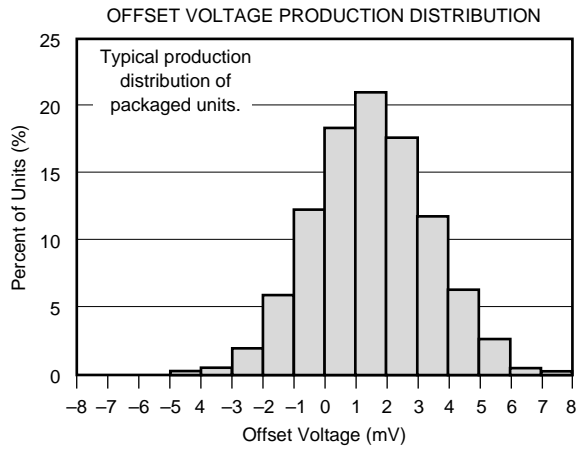

APPLICATIONS INFORMATION

OPA353 series op amps are fabricated on a state-of-the-art 0.6 micron CMOS process. They are unity-gain stable and suitable for a wide range of general purpose applications. Rail-to-rail input/output make them ideal for driving sampling A/D converters. They are well suited for controlling the output power in cell phones. These applications often require high speed and low noise. In addition, the OPA353 series offers a low cost solution for general purpose and consumer video applications (75Ω drive capability).

Excellent ac performance makes the OPA353 series well suited for audio applications. Their bandwidth, slew rate, low noise (5nV/√Hz), low THD (0.0006%), and small package options are ideal for these applications. The class AB output stage is capable of driving 600Ω loads connected to any point between V+ and ground.

Rail-to-rail input and output swing significantly increases dynamic range, especially in low voltage supply applications. Figure 1 shows the input and output waveforms for

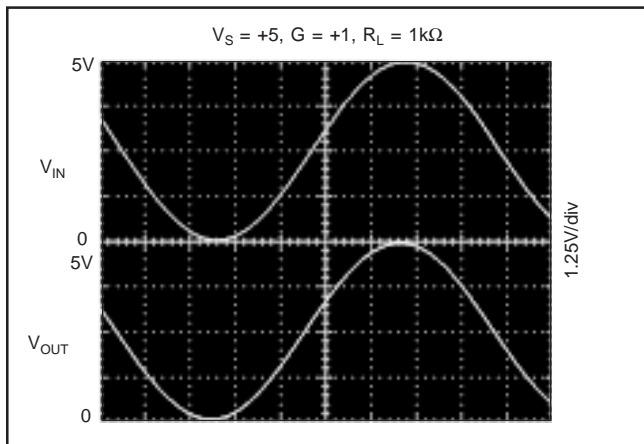

FIGURE 1. Rail-to-Rail Input and Output.

the OPA353 in unity-gain configuration. Operation is from a single +5V supply with a 1kΩ load connected to V_S/2. The input is a 5Vp-p sinusoid. Output voltage is approximately 4.95Vp-p.

Power supply pins should be bypassed with 0.01μF ceramic capacitors.

OPERATING VOLTAGE

OPA353 series op amps are fully specified from +2.7V to +5.5V. However, supply voltage may range from +2.5V to +5.5V. Parameters are guaranteed over the specified supply range—a unique feature of the OPA353 series. In addition, many specifications apply from -40°C to +85°C. Most behavior remains virtually unchanged throughout the full operating voltage range. Parameters which vary significantly with operating voltages or temperature are shown in the typical performance curves.

RAIL-TO-RAIL INPUT

The guaranteed input common-mode voltage range of the OPA353 series extends 100mV beyond the supply rails. This is achieved with a complementary input stage—an N-channel input differential pair in parallel with a P-channel differential pair (see Figure 2). The N-channel pair is active for input voltages close to the positive rail, typically (V+) - 1.8V to 100mV above the positive supply, while the P-channel pair is on for inputs from 100mV below the negative supply to approximately (V+) - 1.8V. There is a small transition region, typically (V+) - 2V to (V+) - 1.6V, in which both pairs are on. This 400mV transition region can vary ±400mV with process variation. Thus, the transition region (both input stages on) can range from (V+) - 2.4V to (V+) - 2.0V on the low end, up to (V+) - 1.6V to (V+) - 1.2V on the high end.

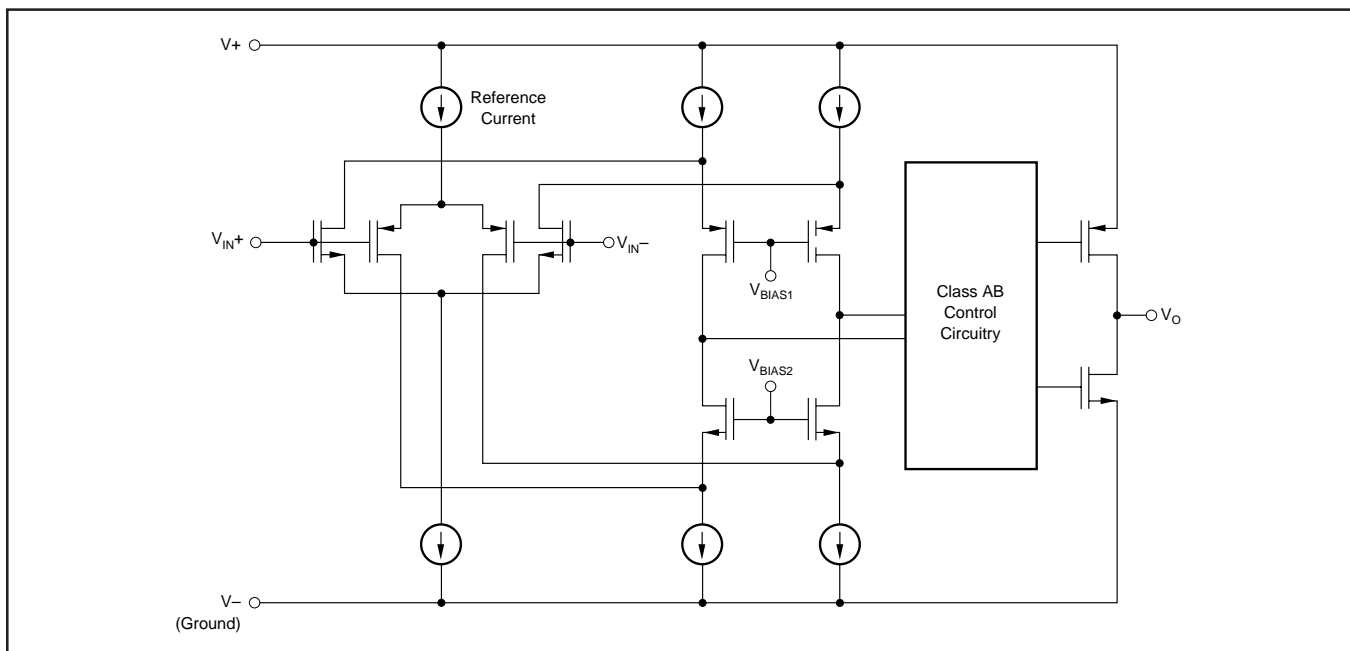

FIGURE 2. Simplified Schematic.

A double-folded cascode adds the signal from the two input pairs and presents a differential signal to the class AB output stage. Normally, input bias current is approximately 500fA. However, large inputs (greater than 300mV beyond the supply rails) can turn on the OPA353's input protection diodes, causing excessive current to flow in or out of the input pins. Momentary voltages greater than 300mV beyond the power supply can be tolerated if the current on the input pins is limited to 10mA. This is easily accomplished with an input resistor as shown in Figure 3. Many input signals are inherently current-limited to less than 10mA, therefore, a limiting resistor is not required.

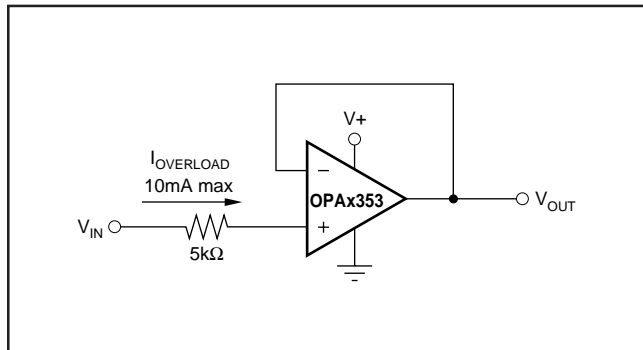

FIGURE 3. Input Current Protection for Voltages Exceeding the Supply Voltage.

RAIL-TO-RAIL OUTPUT

A class AB output stage with common-source transistors is used to achieve rail-to-rail output. For light resistive loads (>10kΩ), the output voltage swing is typically ten millivolts from the supply rails. With heavier resistive loads (600Ω to 10kΩ), the output can swing to within a few tens of millivolts from the supply rails and maintain high open-loop gain. See the typical performance curves “Output Voltage Swing vs Output Current” and “Open-Loop Gain vs Output Voltage.”

CAPACITIVE LOAD AND STABILITY

OPA353 series op amps can drive a wide range of capacitive loads. However, all op amps under certain conditions may become unstable. Op amp configuration, gain, and load value are just a few of the factors to consider when determining stability. An op amp in unity gain configuration is the most susceptible to the effects of capacitive load. The capacitive load reacts with the op amp's output impedance, along with any additional load resistance, to create a pole in the small-signal response which degrades the phase margin.

In unity gain, OPA353 series op amps perform well with large capacitive loads. Increasing gain enhances the amplifier's ability to drive more capacitance. The typical performance curve “Small-Signal Overshoot vs Capacitive Load” shows performance with a 1kΩ resistive load. Increasing load resistance improves capacitive load drive capability.

FEEDBACK CAPACITOR IMPROVES RESPONSE

For optimum settling time and stability with high-impedance feedback networks, it may be necessary to add a feedback capacitor across the feedback resistor, R_F , as shown in Figure 4. This capacitor compensates for the zero created by the feedback network impedance and the OPA353's input capacitance (and any parasitic layout capacitance). The effect becomes more significant with higher impedance networks.

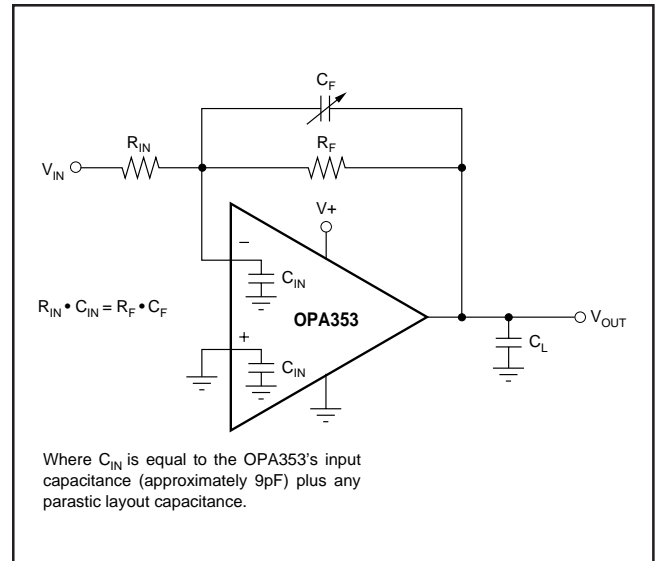

FIGURE 4. Feedback Capacitor Improves Dynamic Performance.

It is suggested that a variable capacitor be used for the feedback capacitor since input capacitance may vary between op amps and layout capacitance is difficult to determine. For the circuit shown in Figure 4, the value of the variable feedback capacitor should be chosen so that the input resistance times the input capacitance of the OPA353 (typically 9pF) plus the estimated parasitic layout capacitance equals the feedback capacitor times the feedback resistor:

$$R_{IN} \cdot C_{IN} = R_F \cdot C_F$$

where C_{IN} is equal to the OPA353's input capacitance (sum of differential and common-mode) plus the layout capacitance. The capacitor can be varied until optimum performance is obtained.

DRIVING A/D CONVERTERS

OPA353 series op amps are optimized for driving medium speed (up to 500kHz) sampling A/D converters. However, they also offer excellent performance for higher speed converters. The OPA353 series provides an effective means of buffering the A/D's input capacitance and resulting charge injection while providing signal gain. For applications requiring high accuracy, the OPA350 series is recommended.

Figure 5 shows the OPA353 driving an ADS7861. The ADS7861 is a dual, 12-bit, 500kHz sampling converter in the small SSOP-24 package. When used with the miniature package options of the OPA353 series, the combination is ideal for space-limited and low power applications. For further information consult the ADS7861 data sheet.

OUTPUT IMPEDANCE

The low frequency open-loop output impedance of the OPA353's common-source output stage is approximately $1k\Omega$. When the op amp is connected with feedback, this value is reduced significantly by the loop gain of the op amp. For example, with 122dB of open-loop gain, the output impedance is reduced in unity-gain to less than 0.001Ω . For each decade rise in the closed-loop gain, the loop gain is reduced by the same amount which results in a ten-fold increase in output impedance (see the typical performance curve, "Output Impedance vs Frequency").

At higher frequencies, the output impedance will rise as the open-loop gain of the op amp drops. However, at these frequencies the output also becomes capacitive due to parasitic capacitance. This prevents the output impedance

from becoming too high, which can cause stability problems when driving capacitive loads. As mentioned previously, the OPA353 has excellent capacitive load drive capability for an op amp with its bandwidth.

VIDEO LINE DRIVER

Figure 6 shows a circuit for a single supply, $G = 2$ composite video line driver. The synchronized outputs of a composite video line driver extend below ground. As shown, the input to the op amp should be ac-coupled and shifted positively to provide adequate signal swing to account for these negative signals in a single-supply configuration.

The input is terminated with a 75Ω resistor and ac-coupled with a $47\mu F$ capacitor to a voltage divider that provides the dc bias point to the input. In Figure 6, this point is approximately $(V-) + 1.7V$. Setting the optimal bias point requires some understanding of the nature of composite video signals. For best performance, one should be careful to avoid the distortion caused by the transition region of the OPA353's complementary input stage. Refer to the discussion of rail-to-rail input.

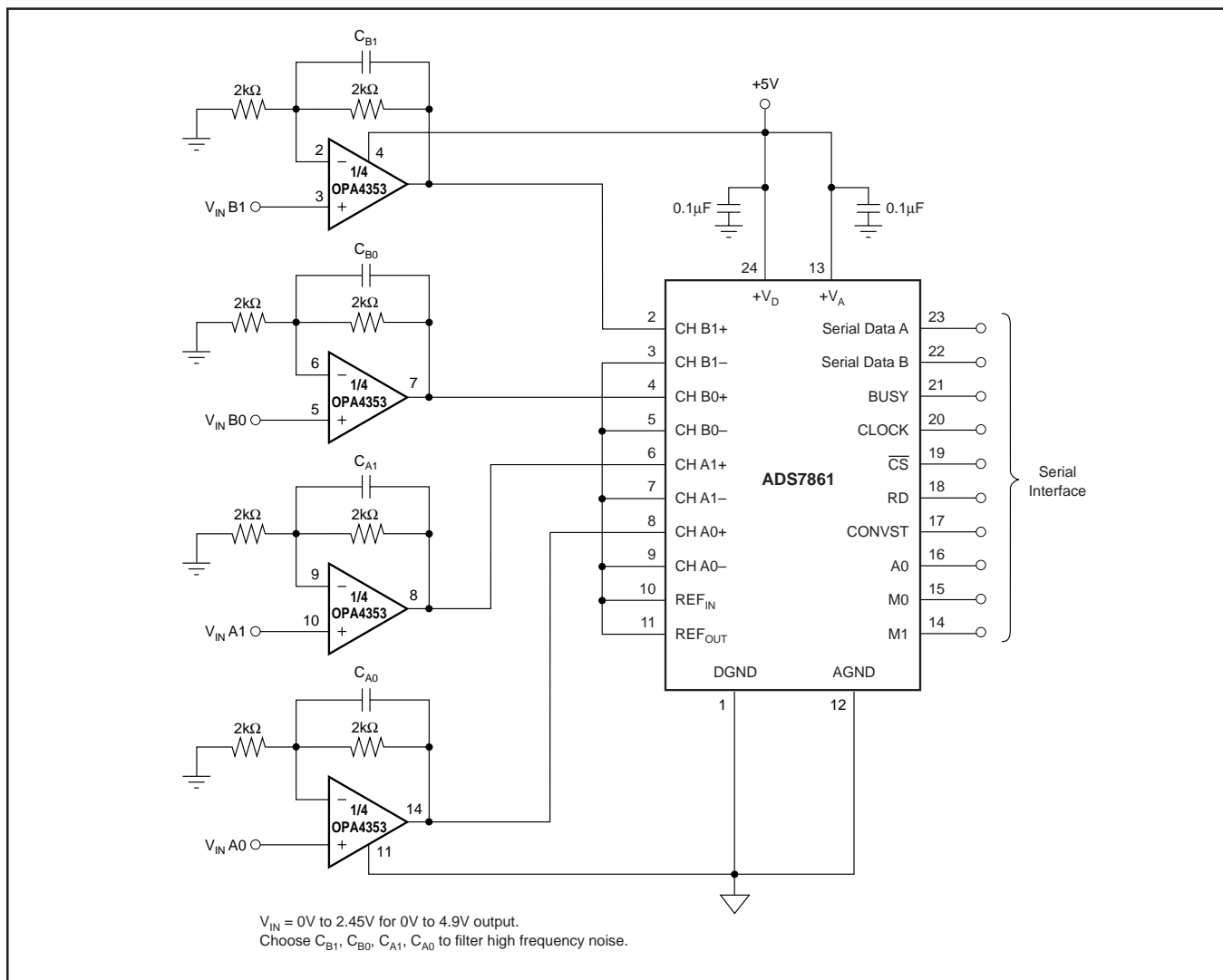

FIGURE 5. OPA4353 Driving Sampling A/D Converter.

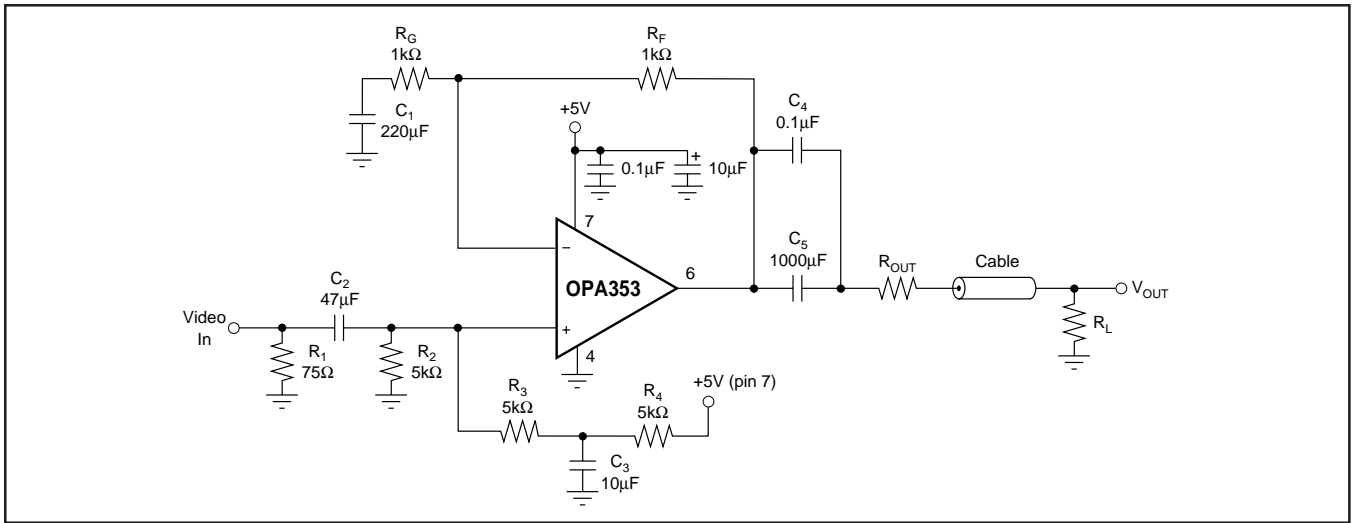

FIGURE 6. Single-Supply Video Line Driver.

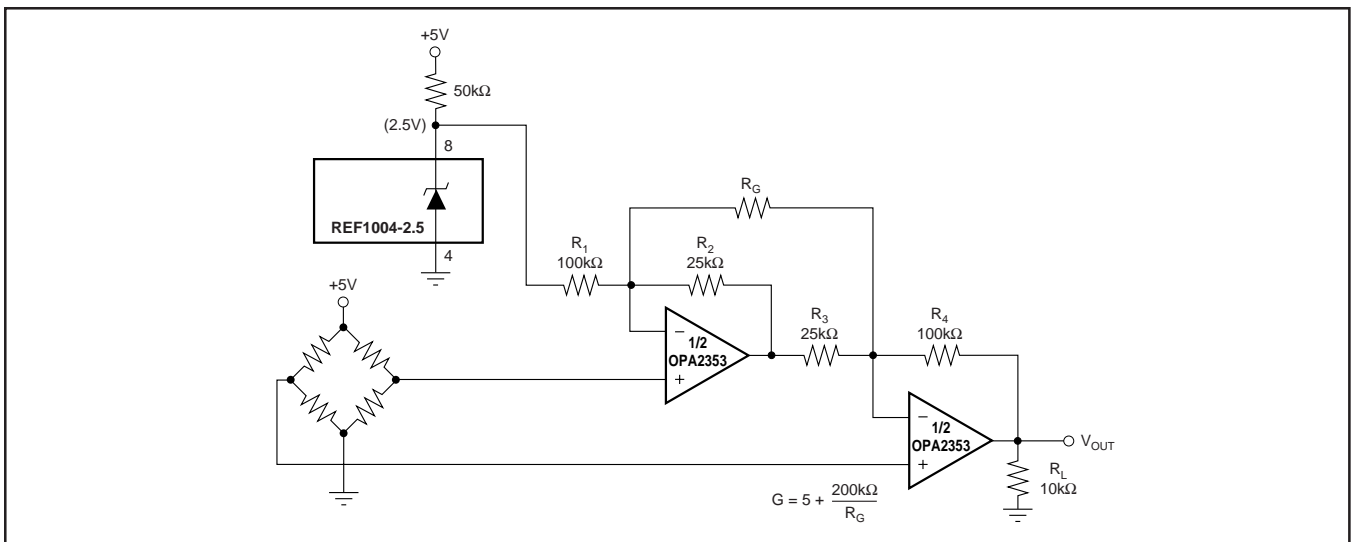

FIGURE 7. Two Op-Amp Instrumentation Amplifier With Improved High Frequency Common-Mode Rejection.

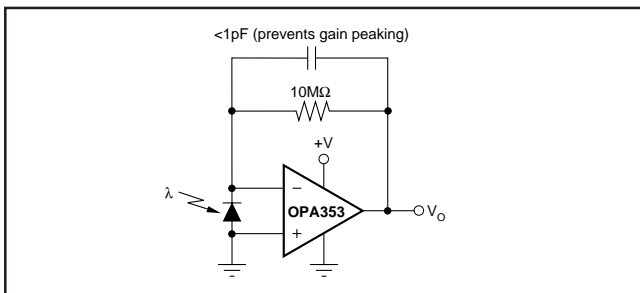

FIGURE 8. Transimpedance Amplifier.

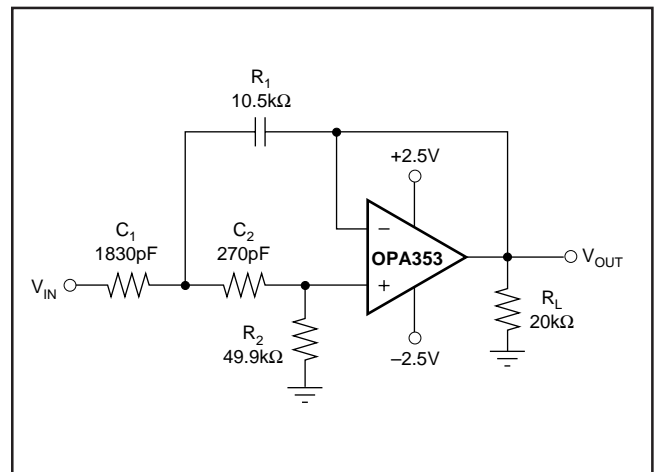

FIGURE 10. 10kHz High-Pass Filter.

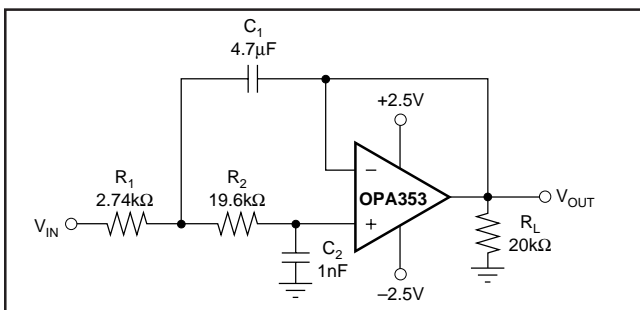

FIGURE 9. 10kHz Low-Pass Filter.

PACKAGING INFORMATION

Orderable part number	Status (1)	Material type (2)	Package Pins	Package qty Carrier	RoHS (3)	Lead finish/ Ball material (4)	MSL rating/ Peak reflow (5)	Op temp (°C)	Part marking (6)
OPA2353EA/250	Last Time Buy	Production	VSSOP (DGK) 8	250 SMALL T&R	Yes	Call TI Nipdau Nipdauag	Level-2-260C-1 YEAR	-40 to 85	E53
OPA2353EA/250.B	Last Time Buy	Production	VSSOP (DGK) 8	250 SMALL T&R	Yes	NIPDAU	Level-2-260C-1 YEAR	-40 to 85	E53
OPA2353EA/250G4	Last Time Buy	Production	VSSOP (DGK) 8	250 SMALL T&R	Yes	NIPDAU	Level-2-260C-1 YEAR	-40 to 85	E53
OPA2353EA/2K5	Active	Production	VSSOP (DGK) 8	2500 LARGE T&R	Yes	Call TI Nipdau Nipdauag	Level-2-260C-1 YEAR	-40 to 85	E53
OPA2353EA/2K5.B	Active	Production	VSSOP (DGK) 8	2500 LARGE T&R	Yes	NIPDAU	Level-2-260C-1 YEAR	-40 to 85	E53
OPA2353EA/2K5G4	Active	Production	VSSOP (DGK) 8	2500 LARGE T&R	Yes	NIPDAU	Level-2-260C-1 YEAR	-40 to 85	E53
OPA2353UA	Last Time Buy	Production	SOIC (D) 8	75 TUBE	Yes	NIPDAU	Level-2-260C-1 YEAR	-40 to 85	OPA 2353UA
OPA2353UA.B	Last Time Buy	Production	SOIC (D) 8	75 TUBE	Yes	NIPDAU	Level-2-260C-1 YEAR	-40 to 85	OPA 2353UA
OPA2353UA/2K5	Active	Production	SOIC (D) 8	2500 LARGE T&R	Yes	NIPDAU	Level-2-260C-1 YEAR	-40 to 85	OPA 2353UA
OPA2353UA/2K5.B	Active	Production	SOIC (D) 8	2500 LARGE T&R	Yes	NIPDAU	Level-2-260C-1 YEAR	-40 to 85	OPA 2353UA
OPA2353UA/2K5G4	Last Time Buy	Production	SOIC (D) 8	2500 LARGE T&R	Yes	NIPDAU	Level-2-260C-1 YEAR	-40 to 85	OPA 2353UA
OPA2353UA/2K5G4.B	Last Time Buy	Production	SOIC (D) 8	2500 LARGE T&R	Yes	NIPDAU	Level-2-260C-1 YEAR	-40 to 85	OPA 2353UA
OPA2353UAG4	Last Time Buy	Production	SOIC (D) 8	75 TUBE	Yes	NIPDAU	Level-2-260C-1 YEAR	-40 to 85	OPA 2353UA
OPA353NA/250	Last Time Buy	Production	SOT-23 (DBV) 5	250 SMALL T&R	Yes	NIPDAU	Level-2-260C-1 YEAR	-40 to 85	D53
OPA353NA/250.B	Last Time Buy	Production	SOT-23 (DBV) 5	250 SMALL T&R	Yes	NIPDAU	Level-2-260C-1 YEAR	-40 to 85	D53
OPA353NA/250G4	Last Time Buy	Production	SOT-23 (DBV) 5	250 SMALL T&R	Yes	NIPDAU	Level-2-260C-1 YEAR	-40 to 85	D53
OPA353NA/250G4.B	Last Time Buy	Production	SOT-23 (DBV) 5	250 SMALL T&R	Yes	NIPDAU	Level-2-260C-1 YEAR	-40 to 85	D53
OPA353NA/3K	Active	Production	SOT-23 (DBV) 5	3000 LARGE T&R	Yes	NIPDAU	Level-2-260C-1 YEAR	-40 to 85	D53

Orderable part number	Status (1)	Material type (2)	Package Pins	Package qty Carrier	RoHS (3)	Lead finish/ Ball material (4)	MSL rating/ Peak reflow (5)	Op temp (°C)	Part marking (6)
OPA353NA/3K.B	Active	Production	SOT-23 (DBV) 5	3000 LARGE T&R	Yes	NIPDAU	Level-2-260C-1 YEAR	-40 to 85	D53
OPA353UA	Last Time Buy	Production	SOIC (D) 8	75 TUBE	Yes	NIPDAU	Level-2-260C-1 YEAR	-40 to 85	OPA 353UA
OPA353UA.B	Last Time Buy	Production	SOIC (D) 8	75 TUBE	Yes	NIPDAU	Level-2-260C-1 YEAR	-40 to 85	OPA 353UA
OPA353UA/2K5	Active	Production	SOIC (D) 8	2500 LARGE T&R	Yes	NIPDAU	Level-2-260C-1 YEAR	-40 to 85	OPA 353UA
OPA353UA/2K5.B	Active	Production	SOIC (D) 8	2500 LARGE T&R	Yes	NIPDAU	Level-2-260C-1 YEAR	-40 to 85	OPA 353UA
OPA353UAG4	Last Time Buy	Production	SOIC (D) 8	75 TUBE	Yes	NIPDAU	Level-2-260C-1 YEAR	-40 to 85	OPA 353UA
OPA4353EA/250	Last Time Buy	Production	SSOP (DBQ) 16	250 SMALL T&R	Yes	NIPDAU	Level-2-260C-1 YEAR	-40 to 85	OPA 4353EA
OPA4353EA/250.B	Last Time Buy	Production	SSOP (DBQ) 16	250 SMALL T&R	Yes	NIPDAU	Level-2-260C-1 YEAR	-40 to 85	OPA 4353EA
OPA4353UA	Last Time Buy	Production	SOIC (D) 14	50 TUBE	Yes	NIPDAU	Level-2-260C-1 YEAR	-	OPA4353UA
OPA4353UA.B	Last Time Buy	Production	SOIC (D) 14	50 TUBE	Yes	NIPDAU	Level-2-260C-1 YEAR	-40 to 85	OPA4353UA
OPA4353UA/2K5	Active	Production	SOIC (D) 14	2500 LARGE T&R	Yes	NIPDAU	Level-2-260C-1 YEAR	-40 to 85	OPA4353UA
OPA4353UA/2K5.B	Active	Production	SOIC (D) 14	2500 LARGE T&R	Yes	NIPDAU	Level-2-260C-1 YEAR	-40 to 85	OPA4353UA
OPA4353UA/2K51G4	Last Time Buy	Production	SOIC (D) 14	2500 LARGE T&R	Yes	NIPDAU	Level-2-260C-1 YEAR	-40 to 85	OPA4353UA
OPA4353UA/2K51G4.B	Last Time Buy	Production	SOIC (D) 14	2500 LARGE T&R	Yes	NIPDAU	Level-2-260C-1 YEAR	-40 to 85	OPA4353UA
OPA4353UAG4	Last Time Buy	Production	SOIC (D) 14	50 TUBE	Yes	NIPDAU	Level-2-260C-1 YEAR	See OPA4353UA	OPA4353UA

⁽¹⁾ **Status:** For more details on status, see our [product life cycle](#).

⁽²⁾ **Material type:** When designated, preproduction parts are prototypes/experimental devices, and are not yet approved or released for full production. Testing and final process, including without limitation quality assurance, reliability performance testing, and/or process qualification, may not yet be complete, and this item is subject to further changes or possible discontinuation. If available for ordering, purchases will be subject to an additional waiver at checkout, and are intended for early internal evaluation purposes only. These items are sold without warranties of any kind.

⁽³⁾ **RoHS values:** Yes, No, RoHS Exempt. See the [TI RoHS Statement](#) for additional information and value definition.

(4) **Lead finish/Ball material:** Parts may have multiple material finish options. Finish options are separated by a vertical ruled line. Lead finish/Ball material values may wrap to two lines if the finish value exceeds the maximum column width.

(5) **MSL rating/Peak reflow:** The moisture sensitivity level ratings and peak solder (reflow) temperatures. In the event that a part has multiple moisture sensitivity ratings, only the lowest level per JEDEC standards is shown. Refer to the shipping label for the actual reflow temperature that will be used to mount the part to the printed circuit board.

(6) **Part marking:** There may be an additional marking, which relates to the logo, the lot trace code information, or the environmental category of the part.

Multiple part markings will be inside parentheses. Only one part marking contained in parentheses and separated by a "~" will appear on a part. If a line is indented then it is a continuation of the previous line and the two combined represent the entire part marking for that device.

Important Information and Disclaimer: The information provided on this page represents TI's knowledge and belief as of the date that it is provided. TI bases its knowledge and belief on information provided by third parties, and makes no representation or warranty as to the accuracy of such information. Efforts are underway to better integrate information from third parties. TI has taken and continues to take reasonable steps to provide representative and accurate information but may not have conducted destructive testing or chemical analysis on incoming materials and chemicals. TI and TI suppliers consider certain information to be proprietary, and thus CAS numbers and other limited information may not be available for release.

In no event shall TI's liability arising out of such information exceed the total purchase price of the TI part(s) at issue in this document sold by TI to Customer on an annual basis.

TAPE AND REEL INFORMATION

QUADRANT ASSIGNMENTS FOR PIN 1 ORIENTATION IN TAPE

*All dimensions are nominal

Device	Package Type	Package Drawing	Pins	SPQ	Reel Diameter (mm)	Reel Width W1 (mm)	A0 (mm)	B0 (mm)	K0 (mm)	P1 (mm)	W (mm)	Pin1 Quadrant
OPA2353EA/250	VSSOP	DGK	8	250	180.0	12.4	5.3	3.4	1.4	8.0	12.0	Q1
OPA2353EA/2K5	VSSOP	DGK	8	2500	330.0	12.4	5.3	3.4	1.4	8.0	12.0	Q1
OPA2353UA/2K5	SOIC	D	8	2500	330.0	12.4	6.4	5.2	2.1	8.0	12.0	Q1
OPA2353UA/2K5G4	SOIC	D	8	2500	330.0	12.4	6.4	5.2	2.1	8.0	12.0	Q1
OPA353NA/250	SOT-23	DBV	5	250	178.0	8.4	3.3	3.2	1.4	4.0	8.0	Q3
OPA353NA/250G4	SOT-23	DBV	5	250	178.0	8.4	3.3	3.2	1.4	4.0	8.0	Q3
OPA353NA/3K	SOT-23	DBV	5	3000	178.0	8.4	3.3	3.2	1.4	4.0	8.0	Q3
OPA353UA/2K5	SOIC	D	8	2500	330.0	12.4	6.4	5.2	2.1	8.0	12.0	Q1
OPA4353EA/250	SSOP	DBQ	16	250	180.0	12.4	6.4	5.2	2.1	8.0	12.0	Q1
OPA4353UA/2K5	SOIC	D	14	2500	330.0	16.4	6.5	9.0	2.1	8.0	16.0	Q1
OPA4353UA/2K51G4	SOIC	D	14	2500	330.0	16.4	6.5	9.0	2.1	8.0	16.0	Q1

TAPE AND REEL BOX DIMENSIONS

*All dimensions are nominal

Device	Package Type	Package Drawing	Pins	SPQ	Length (mm)	Width (mm)	Height (mm)
OPA2353EA/250	VSSOP	DGK	8	250	213.0	191.0	35.0
OPA2353EA/2K5	VSSOP	DGK	8	2500	353.0	353.0	32.0
OPA2353UA/2K5	SOIC	D	8	2500	353.0	353.0	32.0
OPA2353UA/2K5G4	SOIC	D	8	2500	353.0	353.0	32.0
OPA353NA/250	SOT-23	DBV	5	250	445.0	220.0	345.0
OPA353NA/250G4	SOT-23	DBV	5	250	445.0	220.0	345.0
OPA353NA/3K	SOT-23	DBV	5	3000	445.0	220.0	345.0
OPA353UA/2K5	SOIC	D	8	2500	353.0	353.0	32.0
OPA4353EA/250	SSOP	DBQ	16	250	213.0	191.0	35.0
OPA4353UA/2K5	SOIC	D	14	2500	353.0	353.0	32.0
OPA4353UA/2K51G4	SOIC	D	14	2500	353.0	353.0	32.0

TUBE

*All dimensions are nominal

Device	Package Name	Package Type	Pins	SPQ	L (mm)	W (mm)	T (μm)	B (mm)
OPA2353UA	D	SOIC	8	75	506.6	8	3940	4.32
OPA2353UA.B	D	SOIC	8	75	506.6	8	3940	4.32
OPA2353UAG4	D	SOIC	8	75	506.6	8	3940	4.32
OPA353UA	D	SOIC	8	75	506.6	8	3940	4.32
OPA353UA.B	D	SOIC	8	75	506.6	8	3940	4.32
OPA353UAG4	D	SOIC	8	75	506.6	8	3940	4.32
OPA4353UA	D	SOIC	14	50	506.6	8	3940	4.32
OPA4353UA.B	D	SOIC	14	50	506.6	8	3940	4.32
OPA4353UAG4	D	SOIC	14	50	506.6	8	3940	4.32

D0014A



PACKAGE OUTLINE

SOIC - 1.75 mm max height

SMALL OUTLINE INTEGRATED CIRCUIT

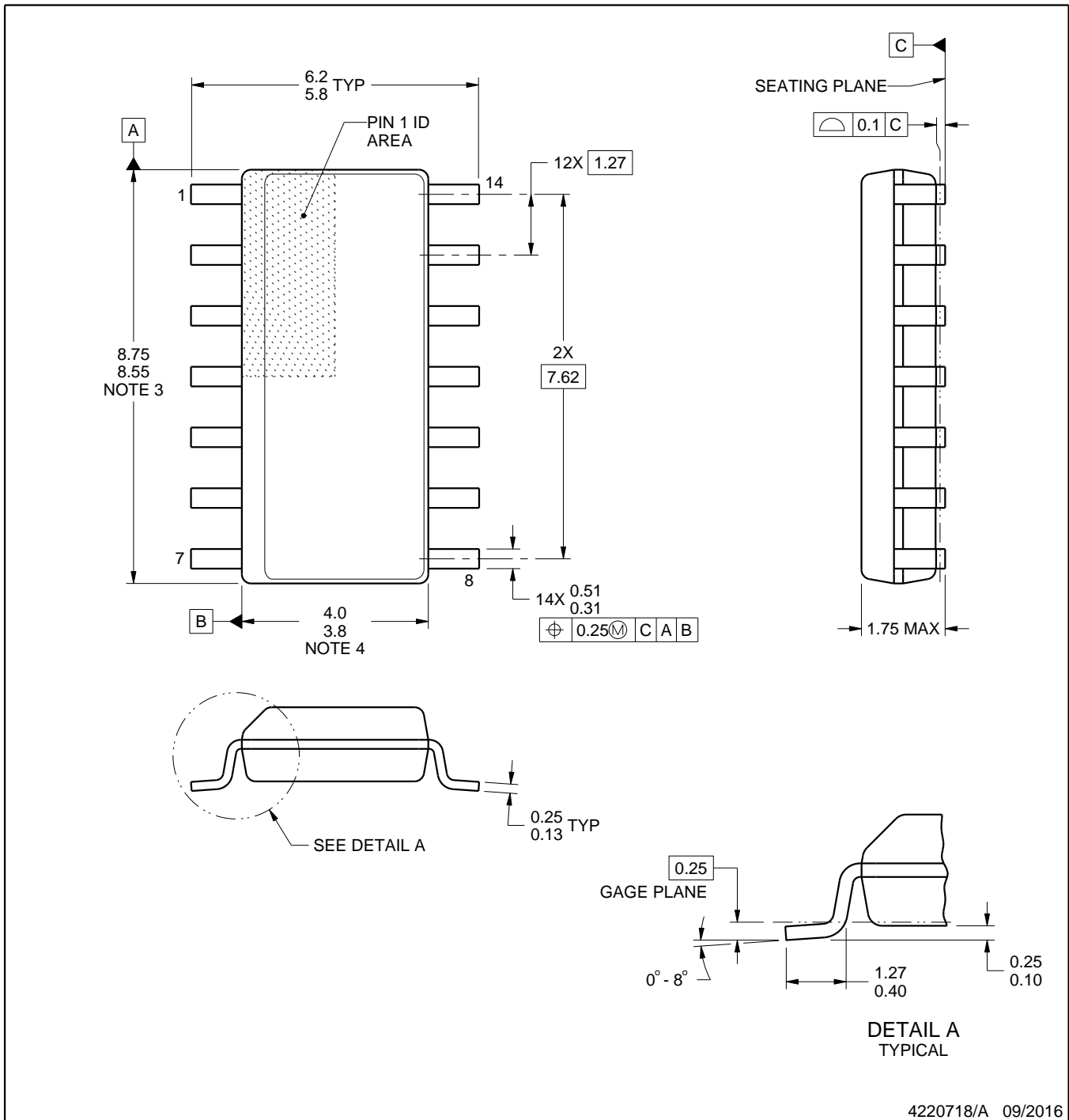

NOTES:

1. All linear dimensions are in millimeters. Dimensions in parenthesis are for reference only. Dimensioning and tolerancing per ASME Y14.5M.
2. This drawing is subject to change without notice.
3. This dimension does not include mold flash, protrusions, or gate burrs. Mold flash, protrusions, or gate burrs shall not exceed 0.15 mm, per side.
4. This dimension does not include interlead flash. Interlead flash shall not exceed 0.43 mm, per side.
5. Reference JEDEC registration MS-012, variation AB.

EXAMPLE BOARD LAYOUT

D0014A

SOIC - 1.75 mm max height

SMALL OUTLINE INTEGRATED CIRCUIT



LAND PATTERN EXAMPLE
SCALE:8X

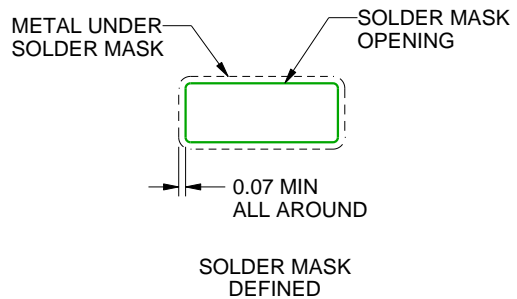
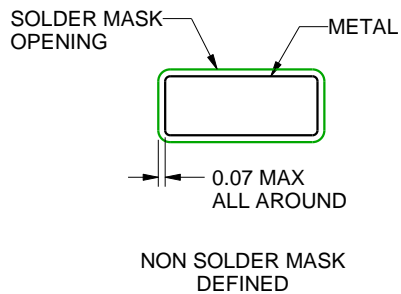

SOLDER MASK DETAILS

4220718/A 09/2016

NOTES: (continued)

6. Publication IPC-7351 may have alternate designs.
7. Solder mask tolerances between and around signal pads can vary based on board fabrication site.



D0008A

PACKAGE OUTLINE

SOIC - 1.75 mm max height

SMALL OUTLINE INTEGRATED CIRCUIT



4214825/C 02/2019

NOTES:

1. Linear dimensions are in inches [millimeters]. Dimensions in parenthesis are for reference only. Controlling dimensions are in inches. Dimensioning and tolerancing per ASME Y14.5M.
2. This drawing is subject to change without notice.
3. This dimension does not include mold flash, protrusions, or gate burrs. Mold flash, protrusions, or gate burrs shall not exceed $.006$ [0.15] per side.
4. This dimension does not include interlead flash.
5. Reference JEDEC registration MS-012, variation AA.

EXAMPLE BOARD LAYOUT

D0008A

SOIC - 1.75 mm max height

SMALL OUTLINE INTEGRATED CIRCUIT



LAND PATTERN EXAMPLE
EXPOSED METAL SHOWN
SCALE:8X



SOLDER MASK DETAILS

4214825/C 02/2019

NOTES: (continued)

6. Publication IPC-7351 may have alternate designs.

7. Solder mask tolerances between and around signal pads can vary based on board fabrication site.

EXAMPLE STENCIL DESIGN

D0008A

SOIC - 1.75 mm max height

SMALL OUTLINE INTEGRATED CIRCUIT



SOLDER PASTE EXAMPLE
BASED ON .005 INCH [0.125 MM] THICK STENCIL
SCALE:8X

4214825/C 02/2019

NOTES: (continued)

8. Laser cutting apertures with trapezoidal walls and rounded corners may offer better paste release. IPC-7525 may have alternate design recommendations.
9. Board assembly site may have different recommendations for stencil design.

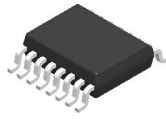

DBQ0016A

PACKAGE OUTLINE

SSOP - 1.75 mm max height

SHRINK SMALL-OUTLINE PACKAGE

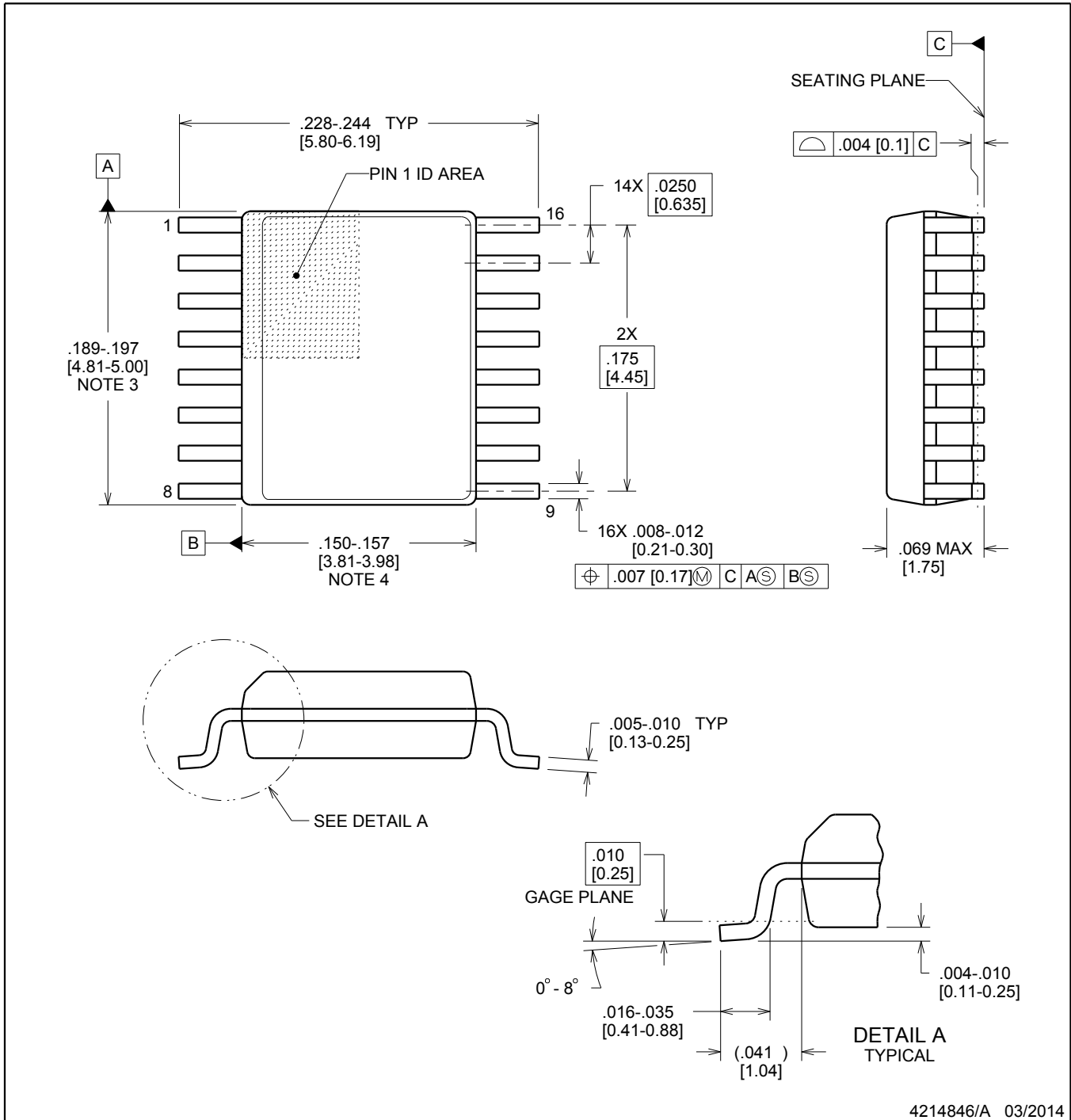

NOTES:

1. Linear dimensions are in inches [millimeters]. Dimensions in parenthesis are for reference only. Controlling dimensions are in inches. Dimensioning and tolerancing per ASME Y14.5M.
2. This drawing is subject to change without notice.
3. This dimension does not include mold flash, protrusions, or gate burrs. Mold flash, protrusions, or gate burrs shall not exceed .006 inch, per side.
4. This dimension does not include interlead flash.
5. Reference JEDEC registration MO-137, variation AB.

EXAMPLE BOARD LAYOUT

DBQ0016A

SSOP - 1.75 mm max height

SHRINK SMALL-OUTLINE PACKAGE

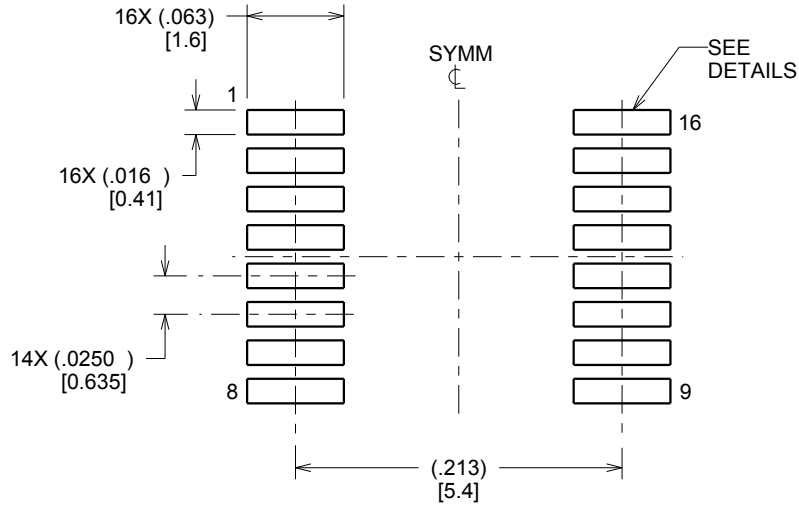

LAND PATTERN EXAMPLE
SCALE:8X

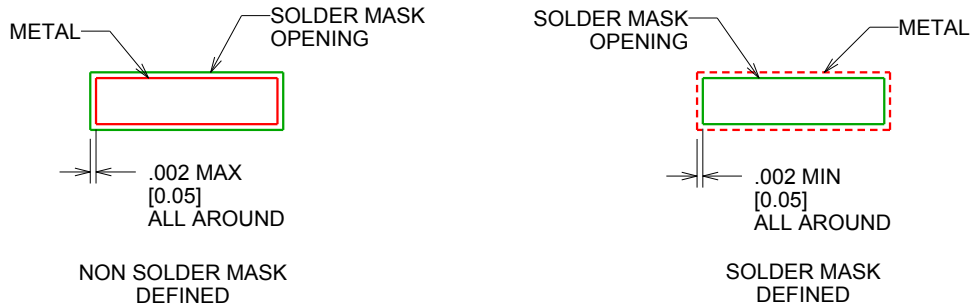

SOLDER MASK DETAILS

4214846/A 03/2014

NOTES: (continued)

6. Publication IPC-7351 may have alternate designs.

7. Solder mask tolerances between and around signal pads can vary based on board fabrication site.

EXAMPLE STENCIL DESIGN

DBQ0016A

SSOP - 1.75 mm max height

SHRINK SMALL-OUTLINE PACKAGE

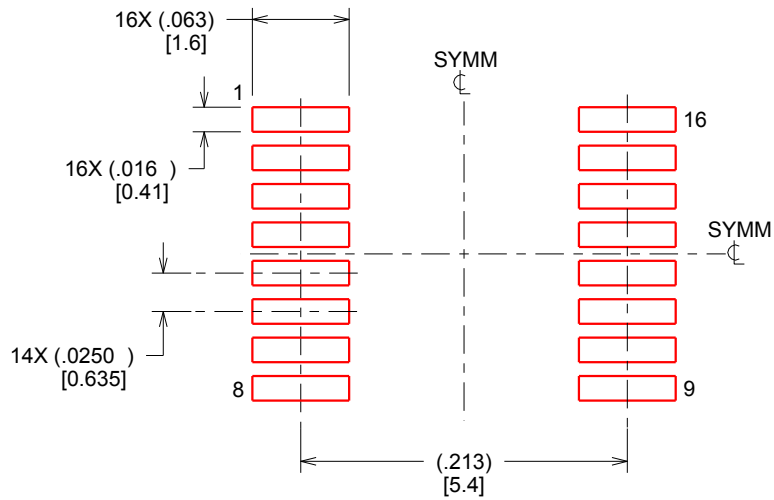

SOLDER PASTE EXAMPLE
BASED ON .005 INCH [0.127 MM] THICK STENCIL
SCALE:8X

4214846/A 03/2014

NOTES: (continued)

8. Laser cutting apertures with trapezoidal walls and rounded corners may offer better paste release. IPC-7525 may have alternate design recommendations.
9. Board assembly site may have different recommendations for stencil design.

EXAMPLE BOARD LAYOUT

DBV0005A

SOT-23 - 1.45 mm max height

SMALL OUTLINE TRANSISTOR



LAND PATTERN EXAMPLE
EXPOSED METAL SHOWN
SCALE:15X



SOLDER MASK DETAILS

4214839/K 08/2024

NOTES: (continued)

- 6. Publication IPC-7351 may have alternate designs.
- 7. Solder mask tolerances between and around signal pads can vary based on board fabrication site.

EXAMPLE STENCIL DESIGN

DBV0005A

SOT-23 - 1.45 mm max height

SMALL OUTLINE TRANSISTOR



SOLDER PASTE EXAMPLE
BASED ON 0.125 mm THICK STENCIL
SCALE:15X

4214839/K 08/2024

NOTES: (continued)

8. Laser cutting apertures with trapezoidal walls and rounded corners may offer better paste release. IPC-7525 may have alternate design recommendations.
9. Board assembly site may have different recommendations for stencil design.

DGK0008A



PACKAGE OUTLINE

VSSOP - 1.1 mm max height

SMALL OUTLINE PACKAGE



4214862/A 04/2023

NOTES:

PowerPAD is a trademark of Texas Instruments.

1. All linear dimensions are in millimeters. Any dimensions in parenthesis are for reference only. Dimensioning and tolerancing per ASME Y14.5M.
2. This drawing is subject to change without notice.
3. This dimension does not include mold flash, protrusions, or gate burrs. Mold flash, protrusions, or gate burrs shall not exceed 0.15 mm per side.
4. This dimension does not include interlead flash. Interlead flash shall not exceed 0.25 mm per side.
5. Reference JEDEC registration MO-187.

EXAMPLE BOARD LAYOUT

DGK0008A

™ VSSOP - 1.1 mm max height

SMALL OUTLINE PACKAGE



LAND PATTERN EXAMPLE
EXPOSED METAL SHOWN
SCALE: 15X



SOLDER MASK DETAILS

4214862/A 04/2023

NOTES: (continued)

6. Publication IPC-7351 may have alternate designs.
7. Solder mask tolerances between and around signal pads can vary based on board fabrication site.
8. Vias are optional depending on application, refer to device data sheet. If any vias are implemented, refer to their locations shown on this view. It is recommended that vias under paste be filled, plugged or tented.
9. Size of metal pad may vary due to creepage requirement.

EXAMPLE STENCIL DESIGN

DGK0008A

TM VSSOP - 1.1 mm max height

SMALL OUTLINE PACKAGE



SOLDER PASTE EXAMPLE
SCALE: 15X

4214862/A 04/2023

NOTES: (continued)

11. Laser cutting apertures with trapezoidal walls and rounded corners may offer better paste release. IPC-7525 may have alternate design recommendations.
12. Board assembly site may have different recommendations for stencil design.

IMPORTANT NOTICE AND DISCLAIMER

TI PROVIDES TECHNICAL AND RELIABILITY DATA (INCLUDING DATASHEETS), DESIGN RESOURCES (INCLUDING REFERENCE DESIGNS), APPLICATION OR OTHER DESIGN ADVICE, WEB TOOLS, SAFETY INFORMATION, AND OTHER RESOURCES "AS IS" AND WITH ALL FAULTS, AND DISCLAIMS ALL WARRANTIES, EXPRESS AND IMPLIED, INCLUDING WITHOUT LIMITATION ANY IMPLIED WARRANTIES OF MERCHANTABILITY, FITNESS FOR A PARTICULAR PURPOSE OR NON-INFRINGEMENT OF THIRD PARTY INTELLECTUAL PROPERTY RIGHTS.

These resources are intended for skilled developers designing with TI products. You are solely responsible for (1) selecting the appropriate TI products for your application, (2) designing, validating and testing your application, and (3) ensuring your application meets applicable standards, and any other safety, security, regulatory or other requirements.

These resources are subject to change without notice. TI grants you permission to use these resources only for development of an application that uses the TI products described in the resource. Other reproduction and display of these resources is prohibited. No license is granted to any other TI intellectual property right or to any third party intellectual property right. TI disclaims responsibility for, and you fully indemnify TI and its representatives against any claims, damages, costs, losses, and liabilities arising out of your use of these resources.

TI's products are provided subject to [TI's Terms of Sale](#), [TI's General Quality Guidelines](#), or other applicable terms available either on ti.com or provided in conjunction with such TI products. TI's provision of these resources does not expand or otherwise alter TI's applicable warranties or warranty disclaimers for TI products. Unless TI explicitly designates a product as custom or customer-specified, TI products are standard, catalog, general purpose devices.

TI objects to and rejects any additional or different terms you may propose.

Copyright © 2026, Texas Instruments Incorporated

Last updated 10/2025