

# SN55LVCP22 QML Class Q、2×2、1Gbps、LVDS クロスポイント・スイッチ

## 1 特長

- QML Class Q、SMD [5962-11242](#)
- 高速 (最高 1000Mbps)
- 低ジッタの完全差動データ・パス
- PRBS =  $2^{23}-1$  パターンで 50ps (標準値) のピーク・ツー・ピーク・ジッタ
- 227mW 未満 (標準値)、313mW (最大値) の合計消費電力
- 出力 (チャンネル間) スキューは 80ps (標準値)
- 2:1 マルチプレクサ、1:2 デマルチプレクサ、リピータ、または 1:2 信号スプリッタとして構成可能
- 入力 は LVDS、LVPECL、CML 信号に対応
- 高速なスイッチ時間: 1.7ns (標準値)
- 短い伝搬遅延: 0.65ns (標準値)
- TIA/EIA-644-A LVDS 標準と相互動作
- 防衛、航空宇宙、医療アプリケーションをサポート
  - 管理されたベースライン
  - 1つのアセンブリ/テスト拠点と 1つの製造拠点
  - 長期間の製品ライフ・サイクルと製品変更通知
  - 製品のトレーサビリティ

## 2 アプリケーション

- [GPS レシーバ](#)
- [防衛無線](#)
- [ソナー](#)
- [追尾フロント・エンド](#)
- [レーダー](#)

## 3 説明

SN55LVCP22 は 2×2 のクロスポイント・スイッチで、パスごとに 1000Mbps を超える速度で動作します。デュアル・チャンネルに広い同相 (0V~4V) レシーバが組み込まれており、LVDS、LVPECL、CML 信号を受信できます。デュアル出力は LVDS ドライバで、低消費電力、低 EMI、高速動作を実現します。SN55LVCP22 は単一デバイスで、チャンネルごとに 2:2 のバッファリング (反復)、1:2 の分割、2:1 の多重化、2×2 のスイッチング、および LVPECL/CML から LVDS へのレベル変換をサポートします。SN55LVCP22 は柔軟に動作するため、単一のデバイスで、光ネットワーク、ワイヤレス・インフラストラクチャ、データ通信システムに見られるフォルト・トレラント・スイッチ・システムの、冗長シリアル・バス伝送の要求 (動作および保護スイッチング・カード) に対応できます。

SN55LVCP22 は、完全差動データ・パスを使用して、低ノイズの生成、高速スイッチング時間、低パルス幅歪み、低ジッタを保証します。出力のチャンネル間スキューは 80ps (標準値) で、すべてのアプリケーションで出力の正確なアライメントを保証します。

### デバイス情報

型番	グレード	パッケージ (1)	本体サイズ (公称)
5962-112420 1QFA	QMLQ	CFP (16)	6.73mm × 10.3mm

(1) 利用可能なすべてのパッケージについては、このデータシートの末尾にある注文情報を参照してください。

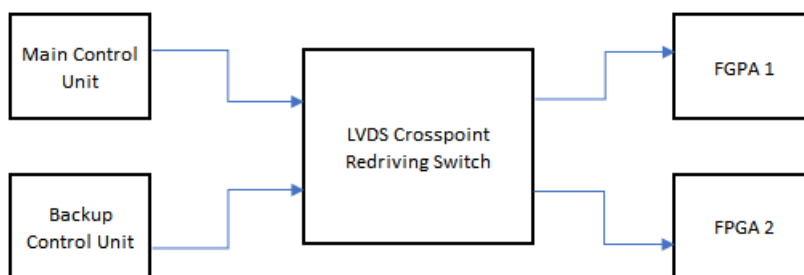

簡略化されたアプリケーション



## Table of Contents

<b>1 特長</b> .....	1	8.2 Functional Block Diagram.....	14
<b>2 アプリケーション</b> .....	1	8.3 Feature Description.....	14
<b>3 説明</b> .....	1	8.4 Device Functional Modes.....	14
<b>4 Revision History</b> .....	2	<b>9 Application and Implementation</b> .....	16
<b>5 Pin Configuration and Functions</b> .....	3	9.1 Application Information.....	16
Pin Functions.....	3	9.2 Typical Application.....	16
<b>6 Specifications</b> .....	4	<b>10 Power Supply Recommendations</b> .....	19
6.1 Absolute Maximum Ratings.....	4	<b>11 Layout</b> .....	20
6.2 Handling Ratings.....	4	11.1 Layout Guidelines.....	20
6.3 Recommended Operating Conditions.....	4	11.2 Layout Example.....	20
6.4 Thermal Information.....	4	<b>12 Device and Documentation Support</b> .....	21
6.5 Electrical Characteristics.....	4	12.1 Trademarks.....	21
6.6 Switching Characteristics.....	6	12.2 静電気放電に関する注意事項.....	21
6.7 Typical Characteristics.....	7	12.3 用語集.....	21
<b>7 Parameter Measurement Information</b> .....	10	<b>13 Mechanical, Packaging, and Orderable Information</b> .....	21
<b>8 Detailed Description</b> .....	14		
8.1 Overview.....	14		

## 4 Revision History

資料番号末尾の英字は改訂を表しています。その改訂履歴は英語版に準じています。

DATE	REVISION	NOTES
September 2020	*	Initial Release

## 5 Pin Configuration and Functions

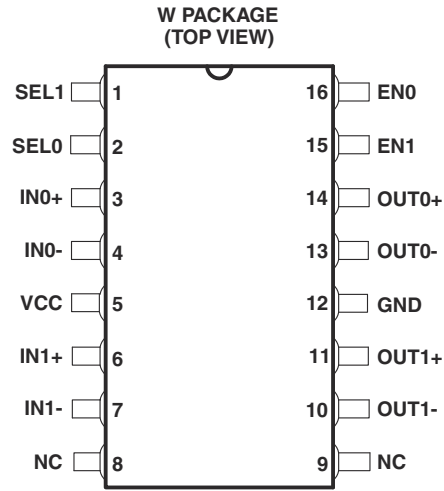

NC - No internal connection

## Pin Functions

TERMINAL		I/O	DESCRIPTION
NAME	NO.		
SEL1	1	Input	Switch Selection Control 1
SEL0	2	Input	Switch Selection Control 2
IN0+	3	Input	LVDS Receiver Positive Input 0
IN0-	4	Input	LVDS Receiver Negative Input 0
VCC	5	Power	3.3V Supply Voltage
IN1+	6	Input	LVDS Receiver Positive Input 1
IN1-	7	Input	LVDS Receiver Negative Input 1
NC	8	N/A	No Internal Connection
NC	9	N/A	No Internal Connection
OUT1-	10	Output	LVDS Driver Negative Output 1
OUT1+	11	Output	LVDS Driver Positive Output 1
GND	12	Ground	Ground
OUT0-	13	Output	LVDS Driver Negative Output 0
OUT0+	14	Output	LVDS Driver Positive Output 0
EN1	15	Input	Output Enable for Driver 1
EN0	16	Input	Output Enable for Driver 0

## 6 Specifications

### 6.1 Absolute Maximum Ratings

over operating free-air temperature range unless otherwise noted<sup>(1)</sup>

	UNIT
Supply voltage <sup>(2)</sup> , $V_{CC}$	–0.5 V to 4 V
CMOS/TTL input voltage (EN0, EN1, SEL0, SEL1)	–0.5 V to 4 V
LVDS receiver input voltage (IN+, IN–)	–0.7 V to 4.3 V
LVDS driver output voltage (OUT+, OUT–)	–0.5 V to 4 V
LVDS output short circuit current	Continuous
Maximum Junction temperature	150°C

- (1) Stresses beyond those listed under *absolute maximum ratings* may cause permanent damage to the device. These are stress ratings only, and functional operation of the device at these or any other conditions beyond those indicated under *recommended operating conditions* is not implied. Exposure to absolute-maximum-rated conditions for extended periods may affect device reliability.
- (2) All voltage values, except differential I/O bus voltages, are with respect to network ground terminals.

### 6.2 Handling Ratings

		MIN	MAX	UNIT	
$T_{stg}$	Storage temperature range	–65	125	°C	
$V_{(ESD)}$	Electrostatic discharge	Human body model (HBM), per ANSI/ESDA/JEDEC JS-001, all pins <sup>(1)</sup>	–5000	5000	V
		Charged device model (CDM), per JEDEC specification JESD22-C101, all pins <sup>(2)</sup>	–500	500	

- (1) JEDEC document JEP155 states that 500-V HBM allows safe manufacturing with a standard ESD control process.
- (2) JEDEC document JEP157 states that 250-V CDM allows safe manufacturing with a standard ESD control process.

### 6.3 Recommended Operating Conditions

		MIN	NOM	MAX	UNIT
Supply voltage, $V_{CC}$		3	3.3	3.6	V
Receiver input voltage		0		4	V
Operating case (top) temperature, $T_C$ <sup>(1)</sup>		–55		125	°C
Magnitude of differential input voltage, $ V_{ID} $		0.1		3	V

- (1) Maximum case temperature operation is allowed as long as the device maximum junction temperature is not exceeded.

### 6.4 Thermal Information

THERMAL METRIC <sup>(1)</sup>		SN55LVCP22A-SP	UNIT
		W (CFP)	
		16 PINS	
$R_{\theta JA}$	Junction-to-ambient thermal resistance	118.1	°C/W
$R_{\theta JC(top)}$	Junction-to-case (top) thermal resistance	51.2	°C/W
$R_{\theta JB}$	Junction-to-board thermal resistance	107.2	°C/W
$\Psi_{JT}$	Junction-to-top characterization parameter	28.4	°C/W
$\Psi_{JB}$	Junction-to-board characterization parameter	95.1	°C/W

- (1) For more information about traditional and new thermal metrics, see the [Semiconductor and IC Package Thermal Metrics](#) application report.

### 6.5 Electrical Characteristics

over recommended operating conditions unless otherwise noted

PARAMETER		TEST CONDITIONS			MIN	TYP <sup>(1)</sup>	MAX	UNIT
<b>CMOS/TTL DC SPECIFICATIONS (EN0, EN1, SEL0, SEL1)</b>								
$V_{IH}$	High-level input voltage				2	1.5	$V_{CC}$	V

over recommended operating conditions unless otherwise noted

PARAMETER		TEST CONDITIONS	MIN	TYP <sup>(1)</sup>	MAX	UNIT
V <sub>IL</sub>	Low-level input voltage		GND	1.5	0.8	V
I <sub>IH</sub>	High-level input current	V <sub>IN</sub> = 3.6 V or 2.0 V, V <sub>CC</sub> = 3.6 V	-25	±3	25	μA
I <sub>IL</sub>	Low-level input current	V <sub>IN</sub> = 0.0 V or 0.8 V, V <sub>CC</sub> = 3.6 V	-15	±1	15	μA
V <sub>CL</sub>	Input clamp voltage	I <sub>CL</sub> = -18 mA		-0.8	-1.5	V

#### LVDS OUTPUT SPECIFICATIONS (OUT0, OUT1)

V <sub>OD</sub>	Differential output voltage	R <sub>L</sub> = 75 Ω, See <a href="#">7-3</a>	255	390	475	mV
		R <sub>L</sub> = 75 Ω, V <sub>CC</sub> = 3.3 V, T <sub>A</sub> = 25°C, See <a href="#">7-3</a>	320	390	430	
Δ V <sub>OD</sub>	Change in differential output voltage magnitude between logic states	V <sub>ID</sub> = ±100 mV, See <a href="#">7-3</a>	-25		25	mV
V <sub>OS</sub>	Steady-state offset voltage	See <a href="#">7-4</a>	1	1.2	1.45	V
ΔV <sub>OS</sub>	Change in steady-state offset voltage between logic states	See <a href="#">7-4</a>	-25		25	mV
V <sub>OC(PP)</sub>	Peak-to-peak common-mode output voltage	See <a href="#">7-4</a>		50		mV
I <sub>OZ</sub>	High-impedance output current	V <sub>OUT</sub> = GND or V <sub>CC</sub>	-15		15	μA
I <sub>OFF</sub>	Power-off leakage current	V <sub>CC</sub> = 0 V, 1.5 V; V <sub>OUT</sub> = 3.6 V or GND	-15		15	μA
I <sub>OS</sub>	Output short-circuit current	V <sub>OUT+</sub> or V <sub>OUT-</sub> = 0 V			-8	mA
I <sub>OSB</sub>	Both outputs short-circuit current	V <sub>OUT+</sub> and V <sub>OUT-</sub> = 0 V	-8		8	mA
C <sub>O</sub>	Differential output capacitance	V <sub>I</sub> = 0.4 sin(4E6πt) + 0.5 V		3		pF

#### LVDS RECEIVER DC SPECIFICATIONS (IN0, IN1)

V <sub>TH</sub>	Positive-going differential input voltage threshold	See <a href="#">7-2</a> and <a href="#">表 7-1</a>			100	mV
V <sub>TL</sub>	Negative-going differential input voltage threshold	See <a href="#">7-2</a> and <a href="#">表 7-1</a>	-100			mV
V <sub>ID(HYS)</sub>	Differential input voltage hysteresis			20	150	mV
V <sub>CMR</sub>	Common-mode voltage range	V <sub>ID</sub> = 100 mV, V <sub>CC</sub> = 3.0 V to 3.6 V	0.05		3.95	V
I <sub>IN</sub>	Input current	V <sub>IN</sub> = 4 V, V <sub>CC</sub> = 3.6 V or 0.0	-18	±1	18	μA
		V <sub>IN</sub> = 0 V, V <sub>CC</sub> = 3.6V or 0.0	-18	±1	18	
C <sub>IN</sub>	Differential input capacitance	V <sub>I</sub> = 0.4 sin(4E6πt) + 0.5 V		3		pF

#### SUPPLY CURRENT

I <sub>CCQ</sub>	Quiescent supply current	R <sub>L</sub> = 75 Ω, EN0=EN1=High		60	87	mA
I <sub>CCD</sub>	Total supply current	R <sub>L</sub> = 75 Ω, C <sub>L</sub> = 5 pF, 500 MHz (1000 Mbps), EN0=EN1=High		63	87	mA
I <sub>CCZ</sub>	3-state supply current	EN0 = EN1 = Low		25	35	mA

(1) All typical values are at 25°C and with a 3.3-V supply.

## 6.6 Switching Characteristics

over recommended operating conditions unless otherwise noted

parameter		TEST CONDITIONS	MIN	TYP	MAX	UNIT
$t_{SET}$	Input to SEL setup time	See <a href="#">7-7</a>		0.8	2.2	ns
$t_{HOLD}$	Input to SEL hold time	See <a href="#">7-7</a>		1.0	2.2	ns
$t_{SWITCH}$	SEL to switched output	See <a href="#">7-7</a>		1.7	2.6	ns
$t_{PHZ}$	Disable time, high-level-to-high-impedance	See <a href="#">7-6</a>		2	8	ns
$t_{PLZ}$	Disable time, low-level-to-high-impedance	See <a href="#">7-6</a>		2	8	ns
$t_{PZH}$	Enable time, high-impedance -to-high-level output	See <a href="#">7-6</a>		2	8	ns
$t_{PZL}$	Enable time, high-impedance-to-low-level output	See <a href="#">7-6</a>		2	8	ns
$t_{LHT}$	Differential output signal rise time (20%-80%) <sup>(1)</sup>	$C_L = 5$ pF, See <a href="#">7-5</a>		280	620	ps
$t_{HLT}$	Differential output signal fall time (20%-80%) <sup>(1)</sup>	$C_L = 5$ pF, See <a href="#">7-5</a>		280	620	ps
$t_{JIT}$	Added peak-to-peak jitter <sup>(3)</sup>	$V_{ID} = 200$ mV, 50% duty cycle, $V_{CM} = 1.2$ V, 50 MHz, $C_L = 5$ pF		13.7	22.2	ps
		$V_{ID} = 200$ mV, 50% duty cycle, $V_{CM} = 1.2$ V, 240 MHz, $C_L = 5$ pF		13.4	24.5	
		$V_{ID} = 200$ mV, 50% duty cycle, $V_{CM} = 1.2$ V, 500 MHz, $C_L = 5$ pF		14.4	35.7	
		$V_{ID} = 200$ mV, PRBS = 2 <sup>15</sup> -1 data pattern, $V_{CM} = 1.2$ V, 240 Mbps, $C_L = 5$ pF		68.3	204	ps
		$V_{ID} = 200$ mV, PRBS = 2 <sup>15</sup> -1 data pattern, $V_{CM} = 1.2$ V, 1000 Mbps, $C_L = 5$ pF		73.2	282	
$t_{Jrms}$	Added random jitter (rms) <sup>(3)</sup>	$V_{ID} = 200$ mV, 50% duty cycle, $V_{CM} = 1.2$ V, 50 MHz, $C_L = 5$ pF		0.97	1.5	pSRMS
		$V_{ID} = 200$ mV, 50% duty cycle, $V_{CM} = 1.2$ V, 240 MHz, $C_L = 5$ pF		0.85	1.53	
		$V_{ID} = 200$ mV, 50% duty cycle, $V_{CM} = 1.2$ V, 500 MHz, $C_L = 5$ pF		0.86	1.79	
$t_{PLHD}$	Propagation delay time, low-to-high-level output <sup>(1)</sup>		200	650	2350	ps
$t_{PHLD}$	Propagation delay time, high-to-low-level output <sup>(1)</sup>		200	650	2350	ps
$t_{skew}$ <sup>(5)</sup>	Pulse skew ( $ t_{PLHD} - t_{PHLD} $ ) <sup>(2)</sup>	$C_L = 5$ pF, See <a href="#">7-5</a>		45	160	ps
$t_{CCS}$	Output channel-to-channel skew, splitter mode	$C_L = 5$ pF, See <a href="#">7-5</a>		80		ps
$f_{MAX}$ <sup>(5)</sup>	Maximum operating frequency <sup>(4)</sup>		1			GHz

(1) Input:  $V_{IC} = 1.2$  V,  $V_{ID} = 200$  mV, 50% duty cycle, 1 MHz,  $t_r/t_f = 500$  ps

(2)  $t_{skew}$  is the magnitude of the time difference between the  $t_{PLHD}$  and  $t_{PHLD}$  of any output of a single device.

(3) Not production tested.

(4) Signal generator conditions: 50% duty cycle,  $t_r$  or  $t_f \leq 100$  ps (10% to 90%), transmitter output criteria: duty cycle = 45% to 55%  $V_{OD} \geq 300$  mV.

(5)  $t_{skew}$  and  $f_{MAX}$  parameters are guaranteed by characterization, but not production tested.

## 6.7 Typical Characteristics

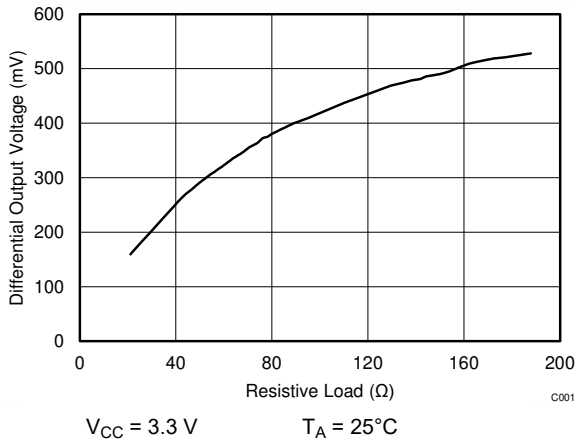

**6-1. Differential Output Voltage vs Resistive Load**

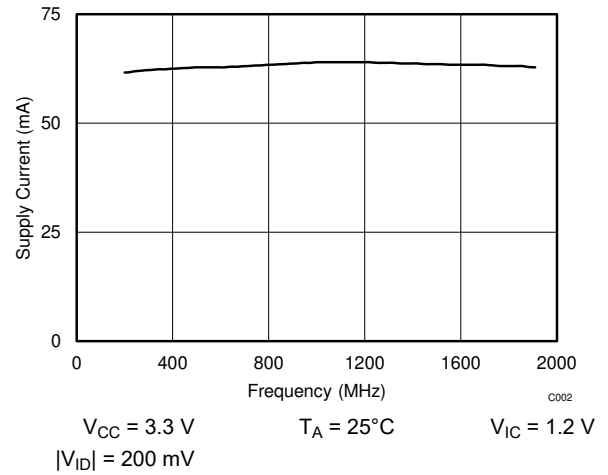

**6-2. Supply Current vs Frequency**

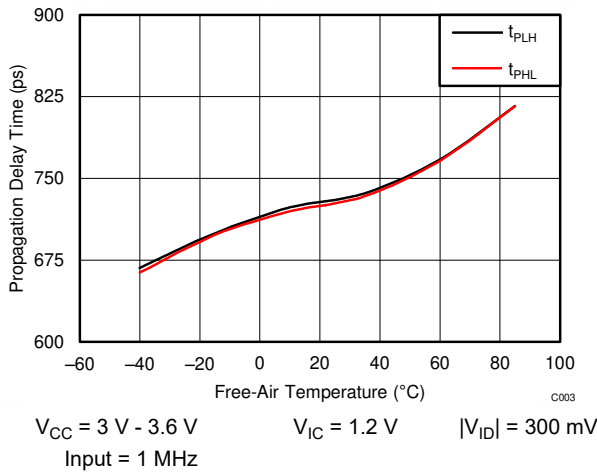

**6-3. Propagation Delay Time vs Free-Air Temperature**

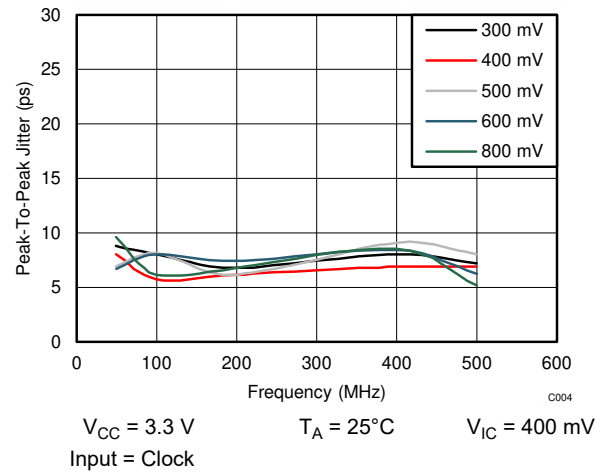

**6-4. Peak-To-Peak Jitter vs Frequency**

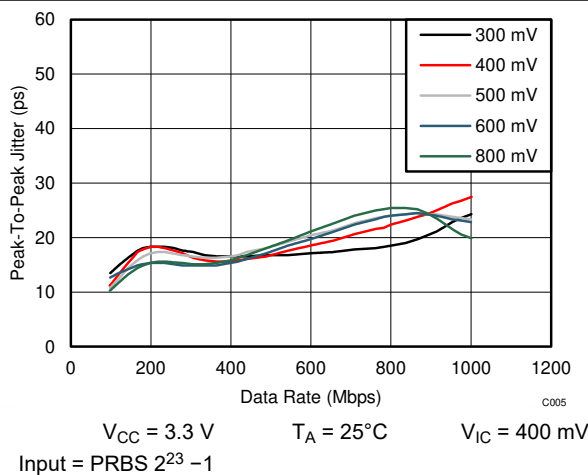

**6-5. Peak-To-Peak Jitter vs Data Rate**

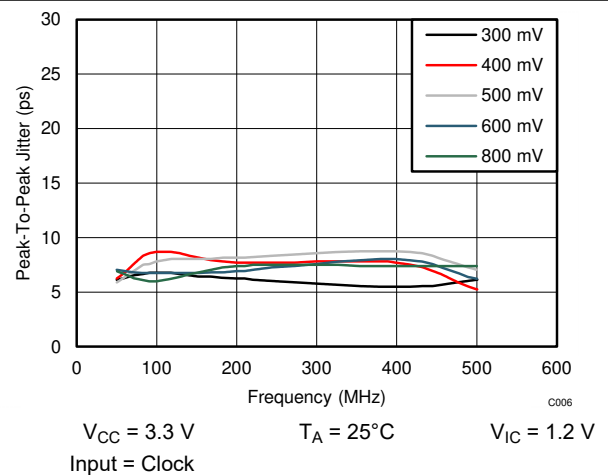

**6-6. Peak-To-Peak Jitter vs Frequency**

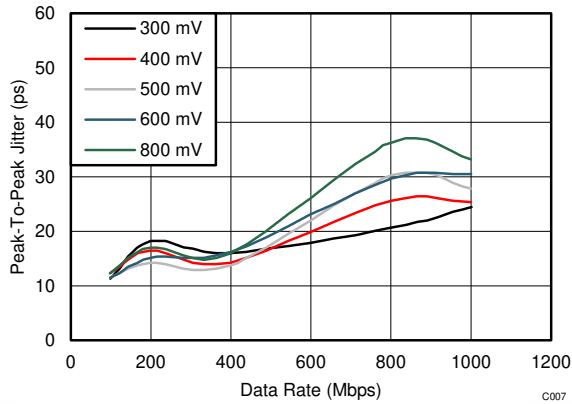

$V_{CC} = 3.3\text{ V}$      $T_A = 25^\circ\text{C}$      $V_{IC} = 1.2\text{ V}$   
 Input = PRBS  $2^{23} - 1$

**6-7. Peak-To-Peak Jitter vs Data Rate**

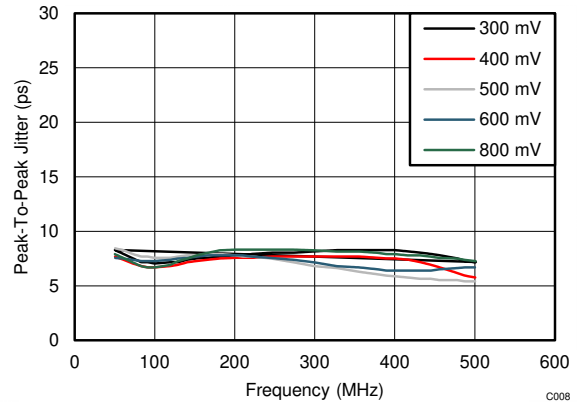

$V_{CC} = 3.3\text{ V}$      $T_A = 25^\circ\text{C}$      $V_{IC} = 1.6\text{ V}$   
 Input = Clock

**6-8. Peak-To-Peak Jitter vs Frequency**

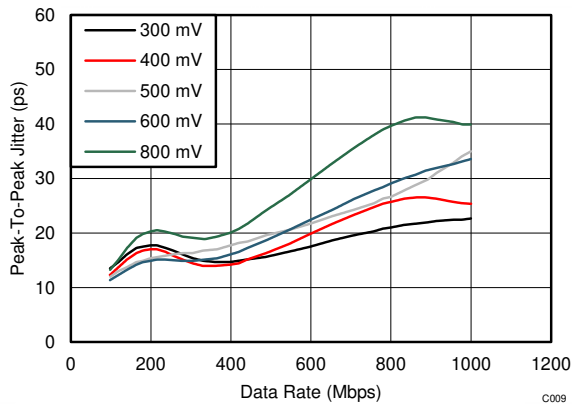

$V_{CC} = 3.3\text{ V}$      $T_A = 25^\circ\text{C}$      $V_{IC} = 1.6\text{ V}$   
 Input = PRBS  $2^{23} - 1$

**6-9. Peak-To-Peak Jitter vs Data Rate**

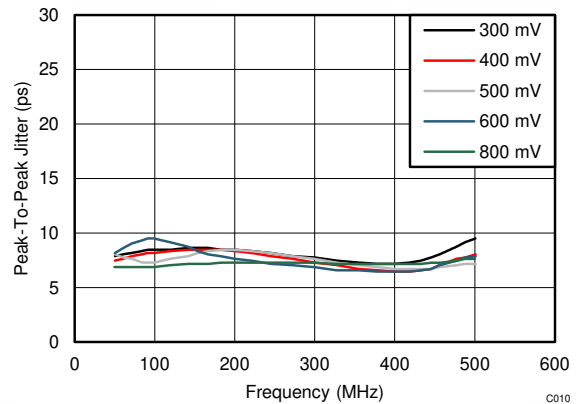

$V_{CC} = 3.3\text{ V}$      $T_A = 25^\circ\text{C}$      $V_{IC} = 3.3\text{ V}$   
 Input = Clock

**6-10. Peak-To-Peak Jitter vs Frequency**

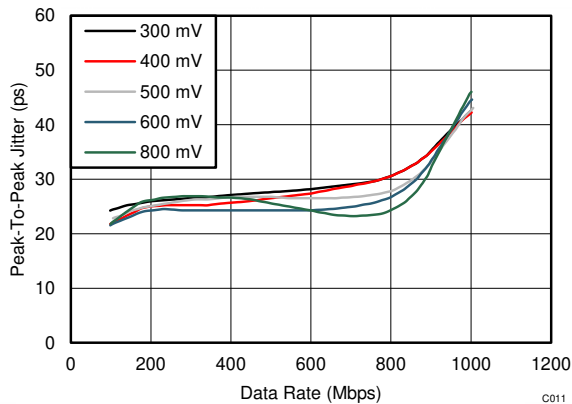

$V_{CC} = 3.3\text{ V}$      $T_A = 25^\circ\text{C}$      $V_{IC} = 3.3\text{ V}$   
 Input = PRBS  $2^{23} - 1$

**6-11. Peak-To-Peak Jitter vs Data Rate**

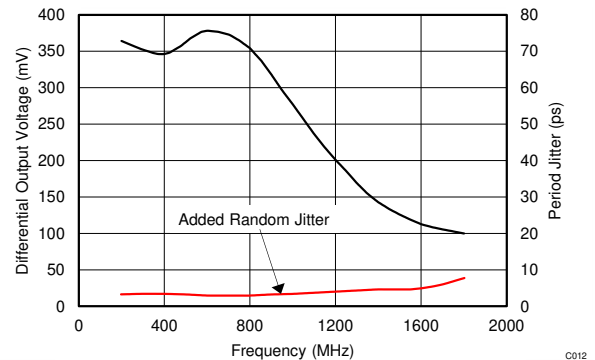

$V_{CC} = 3.3\text{ V}$      $T_A = 25^\circ\text{C}$      $V_{IC} = 1.2\text{ V}$   
 $|V_{ID}| = 200\text{ mV}$

**6-12. Differential Output Voltage vs Frequency**



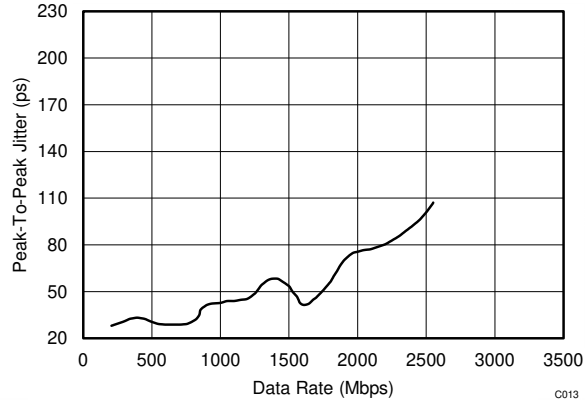

$V_{CC} = 3.3\text{ V}$   
 $|V_{ID}| = 200\text{ mV}$

$T_A = 25^\circ\text{C}$   
Input = PRBS  $2^{23} - 1$

$V_{IC} = 1.2\text{ V}$

**6-13. Peak-To-Peak Jitter vs Data Rate**

## 7 Parameter Measurement Information



图 7-1. Equivalent Input and Output Schematic Diagrams



图 7-2. Voltage And Current Definitions

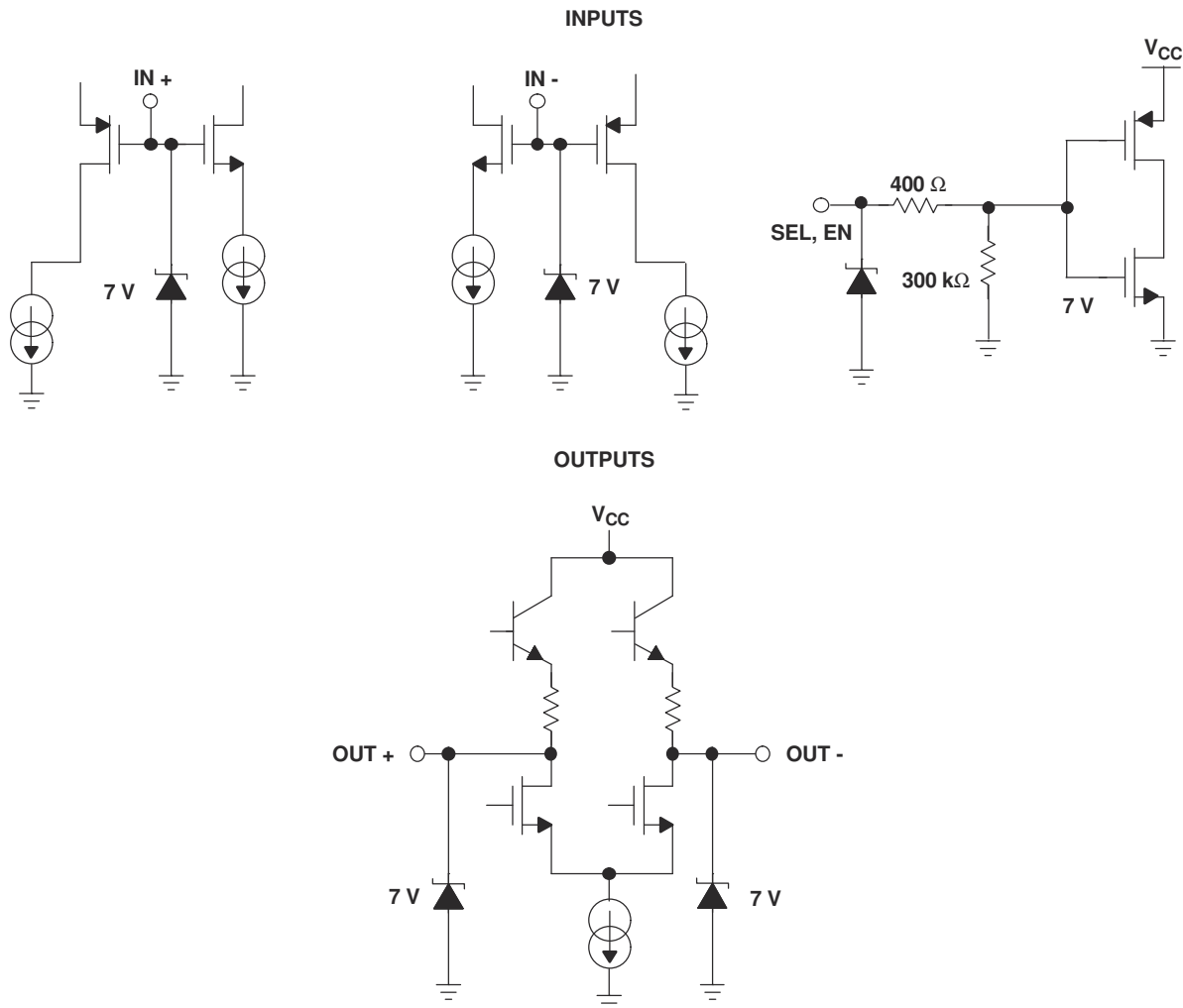

图 7-3. Differential Output Voltage ( $V_{OD}$ ) Test Circuit

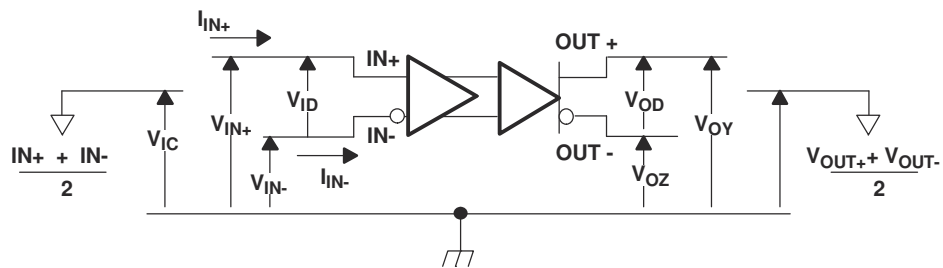

All input pulses are supplied by a generator having the following characteristics:  $t_r$  or  $t_f \leq 1$  ns, pulse-repetition rate (PRR) = 0.5 Mpps, pulse width =  $500 \pm 10$  ns;  $R_L = 100 \Omega$ ;  $C_L$  includes instrumentation and fixture capacitance within 0,06 mm of the D.U.T.; the measurement of  $V_{OC(PP)}$  is made on test equipment with a  $-3$  dB bandwidth of at least 300 MHz.

7-4. Test Circuit And Definitions For The Driver Common-Mode Output Voltage

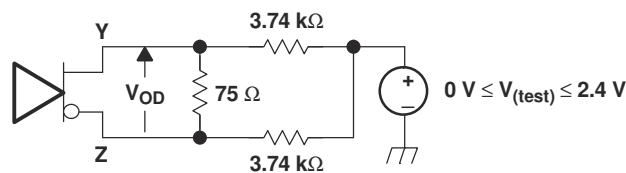
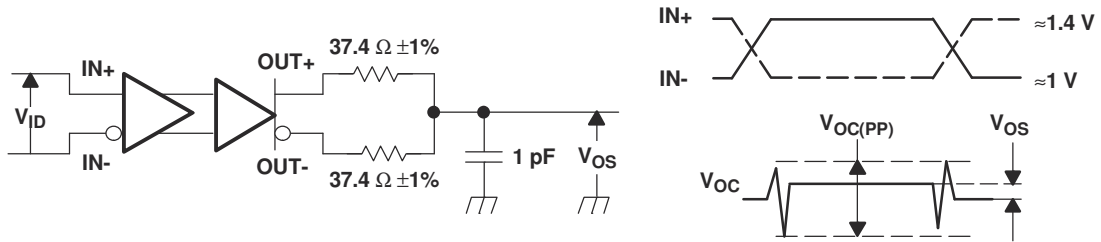
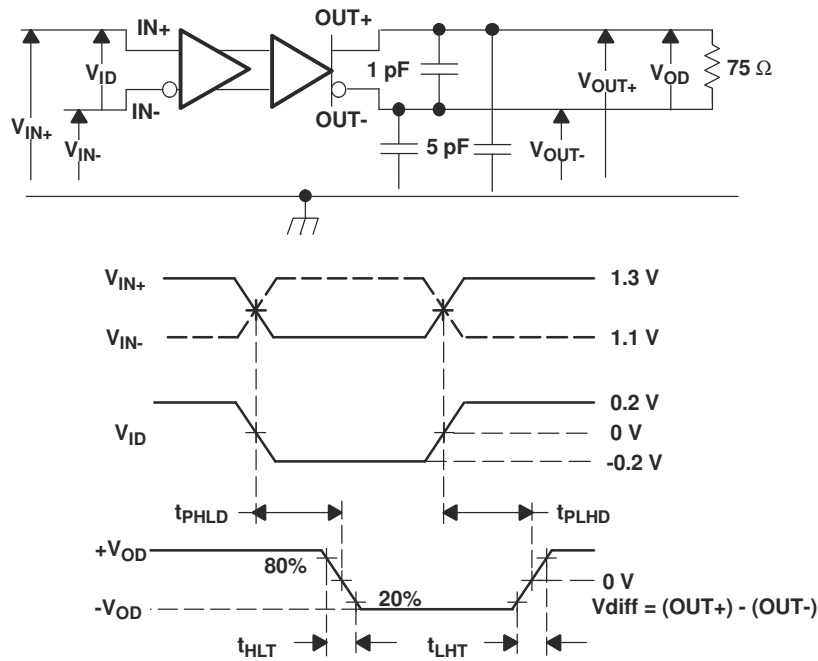

All input pulses are supplied by a generator having the following characteristics:  $t_r$  or  $t_f \leq .25$  ns, pulse-repetition rate (PRR) = 0.5 Mpps, pulse width =  $500 \pm 10$  ns.  $C_L$  includes instrumentation and fixture capacitance within 0,06 mm of the D.U.T.

7-5. Timing Test Circuit And Waveforms

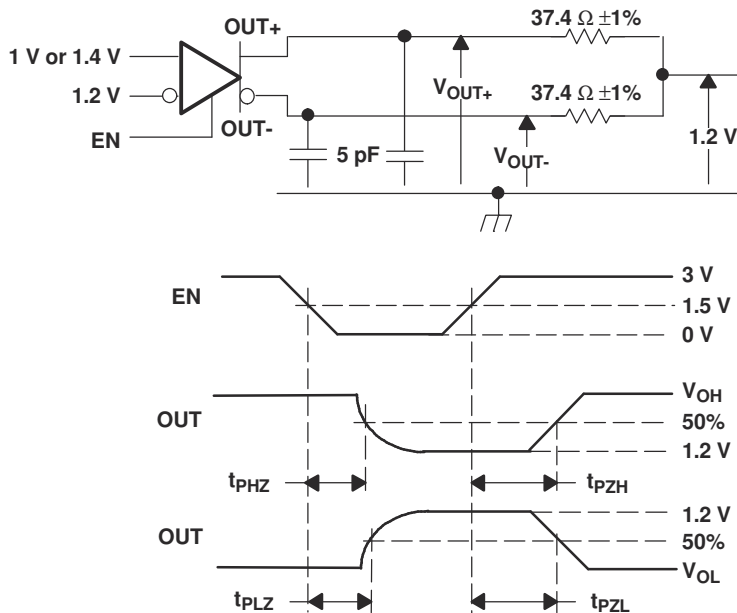

All input pulses are supplied by a generator having the following characteristics:  $t_r$  or  $t_f \leq 1$  ns, pulse-repetition rate (PRR) = 0.5 Mpps, pulse width =  $500 \pm 10$  ns.  $C_L$  includes instrumentation and fixture capacitance within 0,06 mm of the D.U.T.

图 7-6. Enable And Disable Time Circuit And Definitions

表 7-1. Receiver Input Voltage Threshold Test

APPLIED VOLTAGES		RESULTING DIFFERENTIAL INPUT VOLTAGE	RESULTING COMMON-MODE INPUT VOLTAGE	OUTPUT <sup>(1)</sup>
V <sub>IA</sub>	V <sub>IB</sub>	V <sub>ID</sub>	V <sub>IC</sub>	
1.25 V	1.15 V	100 mV	1.2 V	H
1.15 V	1.25 V	-100 mV	1.2 V	L
4.0 V	3.9 V	100 mV	3.95 V	H
3.9 V	4.0 V	-100 mV	3.95 V	L
0.1 V	0.0 V	100 mV	0.05 V	H
0.0 V	0.1 V	-100 mV	0.05 V	L
1.7 V	0.7 V	1000 mV	1.2 V	H
0.7 V	1.7 V	-1000 mV	1.2 V	L
4.0 V	3.0 V	1000 mV	3.5 V	H
3.0 V	4.0 V	-1000 mV	3.5 V	L
1.0 V	0.0 V	1000 mV	0.5 V	H
0.0 V	1.0 V	-1000 mV	0.5 V	L

(1) H = high level, L = low level

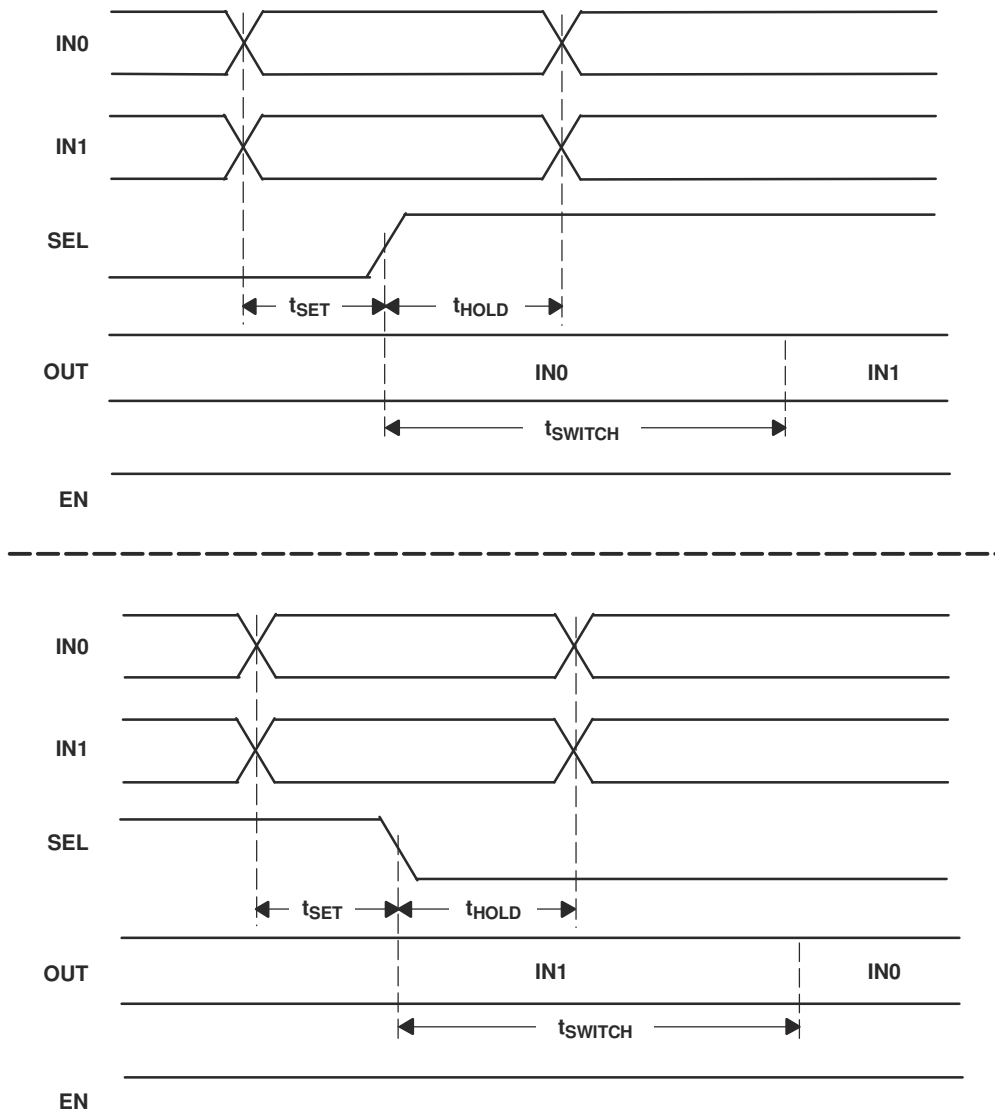

$t_{SET}$  and  $t_{HOLD}$  times specify that data must be in a stable state before and after mux control switches.

**7-7. Input To Select For Both Rising And Falling Edge Setup And Hold Times**

## 8 Detailed Description

### 8.1 Overview

The SN55LVCP22 is a high-speed 1-Gbps 2x2 LVDS redriving cross-point switch that can be used in mux or demux or splitter configurations. The SN55LVCP22 provides multiple signal switching options that allow system implementation flexibility as described in 表 8-1. The SN55LVCP22 incorporates wide common-mode (0 V to 4 V) receivers, allowing for the receipt of LVDS, LVPECL, and CML signals and low-power LVDS drivers to provide high-speed operations. The SN55LVCP22 uses a fully differential data path to ensure low-noise generation, fast switching times, low pulse width distortion, and low jitter.

### 8.2 Functional Block Diagram

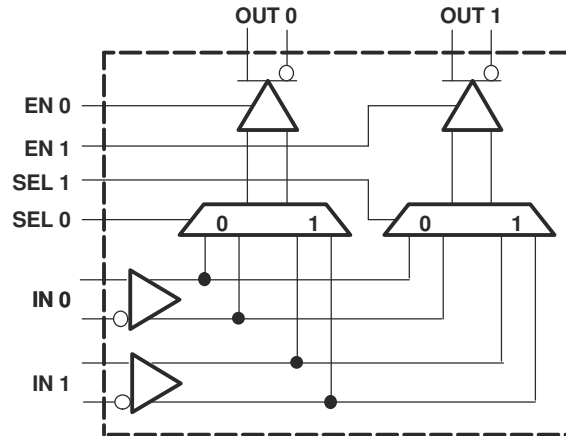

### 8.3 Feature Description

#### 8.3.1 Input Select Pins

SEL0 pin selects which differential input lane will be routed to Lane 0 driver differential output OUT0 and SEL1 pin selects which differential input lane will be routed to Lane 1 driver differential output OUT1

#### 8.3.2 Output Enable Pins

EN0 pin is an active high enable for OUT0 driver differential output and EN1 pin is an active high enable for OUT1 driver differential output.

### 8.4 Device Functional Modes

表 8-1. Function Table

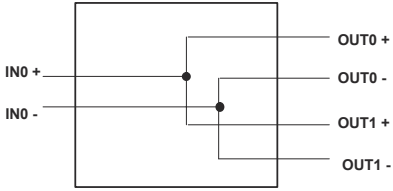
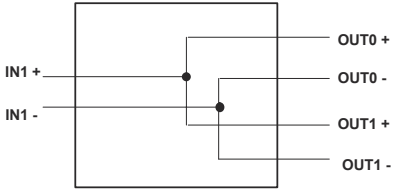
SEL0	SEL1	EN0	EN1	OUT0	OUT1	FUNCTION	SIGNAL FLOW
0	0	1	1	IN0	IN0	1:2 Splitter Input IN0	
1	1	1	1	IN1	IN1	1:2 Splitter Input IN1	

**表 8-1. Function Table (continued)**

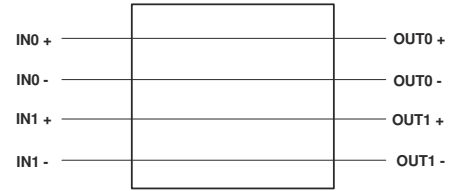
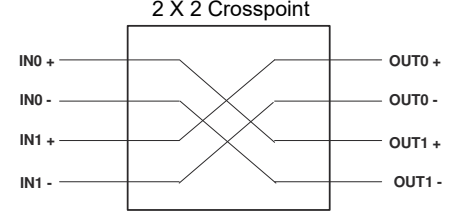
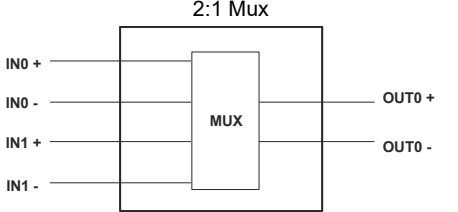
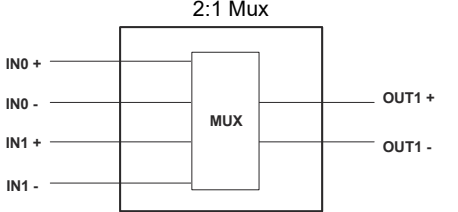
SEL0	SEL1	EN0	EN1	OUT0	OUT1	FUNCTION	SIGNAL FLOW
0	1	1	1	IN0	IN1	2-lane Repeater	<p>Dual Repeater</p> 
1	0	1	1	IN1	IN0	Cross-switch	<p>2 X 2 Crosspoint</p> 
0	X	1	0	IN0	High-Z	2:1 Mux Output OUT0	<p>2:1 Mux</p> 
1				IN1			
X	0	0	1	High-Z	High-Z	2:1 Mux Output OUT1	<p>2:1 Mux</p> 
	1			IN1			

## 9 Application and Implementation

### 9.1 Application Information

The SN55LVCP22 can support different kind of signaling at the receiver with proper termination network. The output drivers will output LVDS differential signals.

### 9.2 Typical Application

#### 9.2.1 Low-Voltage Positive Emitter-Coupled Logic (LVPECL)



图 9-1. Low-Voltage Positive Emitter-Coupled Logic (LVPECL)

##### 9.2.1.1 Design Requirements

表 9-1. Design Parameters

DESIGN PARAMETER	EXAMPLE VALUE
Single-ended termination	50 $\Omega$
$V_{TT}$ termination voltage	$V_{CC} - 2V$

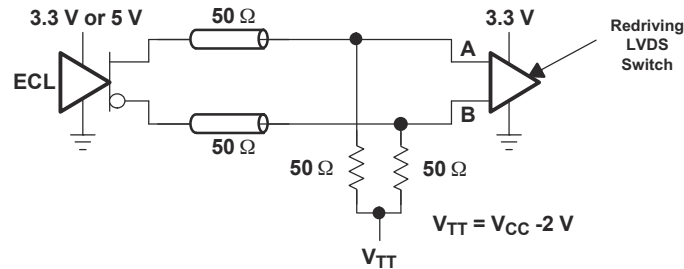
##### 9.2.1.2 Detailed Design Procedure

Use two 50  $\Omega$  termination resistors (as close to the input pins as possible) with termination voltage of  $V_{TT}$  as described in 图 9-1 to receive LVPECL input signals.

#### 9.2.2 Current-Mode Logic (CML)



图 9-2. Current-Mode Logic (CML)

##### 9.2.2.1 Design Requirements

表 9-2. Design Parameters

DESIGN PARAMETER	EXAMPLE VALUE
Single-ended termination	50 $\Omega$
Termination Voltage	$V_{CC} = 3.3V$

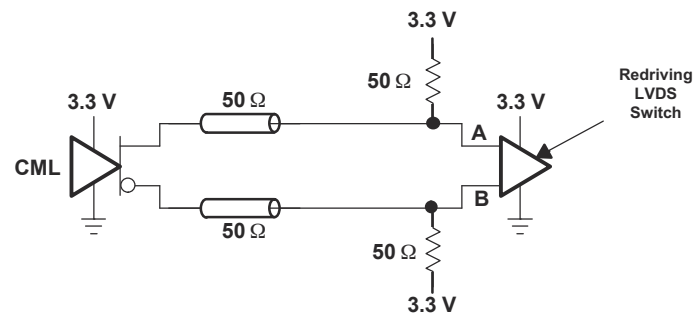
##### 9.2.2.2 Detailed Design Procedure

Use two 50  $\Omega$  termination resistors (as close to the input pin as possible) with termination voltage of  $V_{CC}$  as described in 图 9-2 to receive CML input signals.



### 9.2.3 Single-Ended (LVPECL)



图 9-3. Single-Ended (LVPECL)

#### 9.2.3.1 Design Requirements

表 9-3. Design Parameters

DESIGN PARAMETER	EXAMPLE VALUE
Single-ended termination for input used	50 Ω
$V_{TT}$ termination voltage	$V_{CC} - 2V$
Unused input pull-up termination to $V_{CC}$	1.1 kΩ
Unused input pull-down termination to Ground	1.5 kΩ

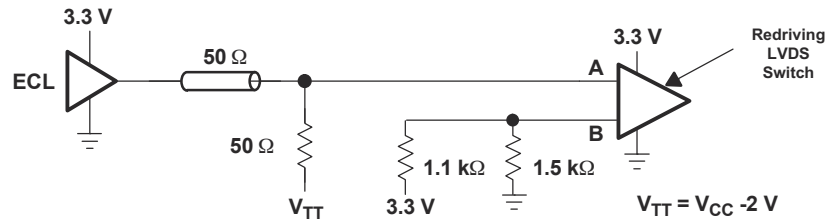
#### 9.2.3.2 Detailed Design Procedure

Use a 50 Ω termination resistor (as close to the input pin as possible) with termination voltage of  $V_{TT}$  as described in 图 9-3 to receive Single-ended LVPECL input signals. Terminate Unused input pin with 1.1 kΩ pull-up to  $V_{CC}$  and 1.5 kΩ pull-down to ground.

### 9.2.4 Low-Voltage Differential Signaling (LVDS)



图 9-4. Low-Voltage Differential Signaling (LVDS)

#### 9.2.4.1 Design Requirements

表 9-4. Design Parameters

DESIGN PARAMETER	EXAMPLE VALUE
Differential Termination	100 Ω

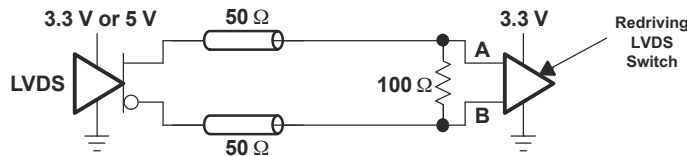
#### 9.2.4.2 Detailed Design Procedure

Use a 100 Ω differential termination resistor (as close to the input pins as possible) as described in 图 9-4 to receive LVDS input signals.

### 9.2.5 Application Curves

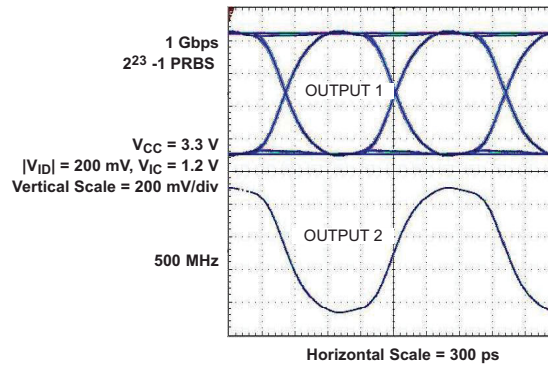

 9-5. LVDS Output

## 10 Power Supply Recommendations

There is no power supply sequence required for SN55LVCP22. It is recommended that at least a 0.1 $\mu$ F decoupling capacitor is placed at the device VCC near the pin.

## 11 Layout

### 11.1 Layout Guidelines

High performance layout practices are paramount for board layout for high speed signals to ensure good signal integrity. Even minor imperfection can cause impedance mismatch resulting reflection. Special care is warranted for traces, connections to device, and connectors.

### 11.2 Layout Example

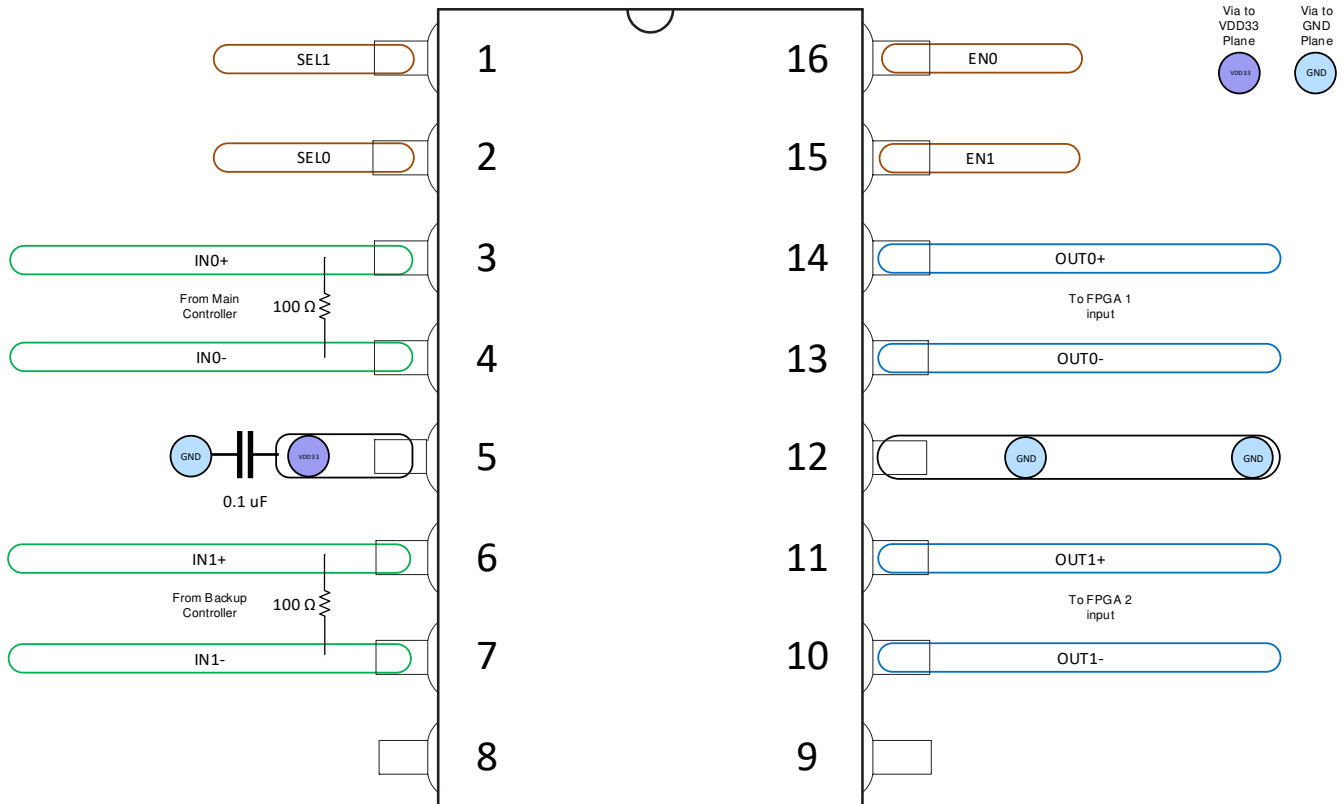

☒ 11-1. Layout Example with LVDS input signals

## 12 Device and Documentation Support

### 12.1 Trademarks

すべての商標は、それぞれの所有者に帰属します。

### 12.2 静電気放電に関する注意事項



この IC は、ESD によって破損する可能性があります。テキサス・インスツルメンツは、IC を取り扱う際には常に適切な注意を払うことを推奨します。正しい ESD 対策をとらないと、デバイスを破損するおそれがあります。

ESD による破損は、わずかな性能低下からデバイスの完全な故障まで多岐にわたります。精密な IC の場合、パラメータがわずかに変化するだけで公表されている仕様から外れる可能性があるため、破損が発生しやすくなっています。

### 12.3 用語集

**TI 用語集** この用語集には、用語や略語の一覧および定義が記載されています。

## 13 Mechanical, Packaging, and Orderable Information

The following pages include mechanical, packaging, and orderable information. This information is the most current data available for the designated devices. This data is subject to change without notice and revision of this document. For browser-based versions of this data sheet, refer to the left-hand navigation.

**PACKAGING INFORMATION**

Orderable Device	Status (1)	Package Type	Package Drawing	Pins	Package Qty	Eco Plan (2)	Lead finish/ Ball material (6)	MSL Peak Temp (3)	Op Temp (°C)	Device Marking (4/5)	Samples
5962-1124201QFA	ACTIVE	CFP	W	16	25	Non-RoHS & Green	SNPB	N / A for Pkg Type	-55 to 125	5962-1124201QF A LVCP22W-SP	Samples

(1) The marketing status values are defined as follows:

**ACTIVE:** Product device recommended for new designs.

**LIFEBUY:** TI has announced that the device will be discontinued, and a lifetime-buy period is in effect.

**NRND:** Not recommended for new designs. Device is in production to support existing customers, but TI does not recommend using this part in a new design.

**PREVIEW:** Device has been announced but is not in production. Samples may or may not be available.

**OBSOLETE:** TI has discontinued the production of the device.

(2) **RoHS:** TI defines "RoHS" to mean semiconductor products that are compliant with the current EU RoHS requirements for all 10 RoHS substances, including the requirement that RoHS substance do not exceed 0.1% by weight in homogeneous materials. Where designed to be soldered at high temperatures, "RoHS" products are suitable for use in specified lead-free processes. TI may reference these types of products as "Pb-Free".

**RoHS Exempt:** TI defines "RoHS Exempt" to mean products that contain lead but are compliant with EU RoHS pursuant to a specific EU RoHS exemption.

**Green:** TI defines "Green" to mean the content of Chlorine (Cl) and Bromine (Br) based flame retardants meet JS709B low halogen requirements of <=1000ppm threshold. Antimony trioxide based flame retardants must also meet the <=1000ppm threshold requirement.

(3) MSL, Peak Temp. - The Moisture Sensitivity Level rating according to the JEDEC industry standard classifications, and peak solder temperature.

(4) There may be additional marking, which relates to the logo, the lot trace code information, or the environmental category on the device.

(5) Multiple Device Markings will be inside parentheses. Only one Device Marking contained in parentheses and separated by a "~" will appear on a device. If a line is indented then it is a continuation of the previous line and the two combined represent the entire Device Marking for that device.

(6) Lead finish/Ball material - Orderable Devices may have multiple material finish options. Finish options are separated by a vertical ruled line. Lead finish/Ball material values may wrap to two lines if the finish value exceeds the maximum column width.

**Important Information and Disclaimer:**The information provided on this page represents TI's knowledge and belief as of the date that it is provided. TI bases its knowledge and belief on information provided by third parties, and makes no representation or warranty as to the accuracy of such information. Efforts are underway to better integrate information from third parties. TI has taken and continues to take reasonable steps to provide representative and accurate information but may not have conducted destructive testing or chemical analysis on incoming materials and chemicals. TI and TI suppliers consider certain information to be proprietary, and thus CAS numbers and other limited information may not be available for release.

In no event shall TI's liability arising out of such information exceed the total purchase price of the TI part(s) at issue in this document sold by TI to Customer on an annual basis.

**OTHER QUALIFIED VERSIONS OF SN55LVCP22 :**

- Space : [SN55LVCP22-SP](#)

NOTE: Qualified Version Definitions:

- Space - Radiation tolerant, ceramic packaging and qualified for use in Space-based application

W (R-GDFP-F16)

CERAMIC DUAL FLATPACK



- NOTES:
- A. All linear dimensions are in inches (millimeters).
  - B. This drawing is subject to change without notice.
  - C. This package can be hermetically sealed with a ceramic lid using glass frit.
  - D. Index point is provided on cap for terminal identification only.
  - E. Falls within MIL STD 1835 GDFP2-F16



## 重要なお知らせと免責事項

TI は、技術データと信頼性データ(データシートを含みます)、設計リソース(リファレンス・デザインを含みます)、アプリケーションや設計に関する各種アドバイス、Web ツール、安全性情報、その他のリソースを、欠陥が存在する可能性のある「現状のまま」提供しており、商品性および特定目的に対する適合性の黙示保証、第三者の知的財産権の非侵害保証を含むいかなる保証も、明示的または黙示的にかかわらず拒否します。

これらのリソースは、TI 製品を使用する設計の経験を積んだ開発者への提供を意図したものです。(1) お客様のアプリケーションに適した TI 製品の選定、(2) お客様のアプリケーションの設計、検証、試験、(3) お客様のアプリケーションに該当する各種規格や、その他のあらゆる安全性、セキュリティ、規制、または他の要件への確実な適合に関する責任を、お客様のみが単独で負うものとし、

上記の各種リソースは、予告なく変更される可能性があります。これらのリソースは、リソースで説明されている TI 製品を使用するアプリケーションの開発の目的でのみ、TI はその使用をお客様に許諾します。これらのリソースに関して、他の目的で複製することや掲載することは禁止されています。TI や第三者の知的財産権のライセンスが付与されている訳ではありません。お客様は、これらのリソースを自身で使用した結果発生するあらゆる申し立て、損害、費用、損失、責任について、TI およびその代理人を完全に補償するものとし、TI は一切の責任を拒否します。

TI の製品は、[TI の販売条件](#)、または [ti.com](https://www.ti.com) やかかる TI 製品の関連資料などのいずれかを通じて提供する適用可能な条項の下で提供されています。TI がこれらのリソースを提供することは、適用される TI の保証または他の保証の放棄の拡大や変更を意味するものではありません。

お客様がいかなる追加条項または代替条項を提案した場合でも、TI はそれらに異議を唱え、拒否します。

郵送先住所 : Texas Instruments, Post Office Box 655303, Dallas, Texas 75265  
Copyright © 2023, Texas Instruments Incorporated