

SN74AVC8T245 8 ビットデュアル電源バス・トランシーバ、構成可能電圧変換、3ステート出力

1 特長

- JESD 78, Class II 準拠で 100mA 超のラッチアップ性能
- JESD 22 を上回る ESD 保護:
 - 8000V、人体モデル (A114-A)
 - 200V マシン・モデル (A115-A)
 - 1000V デバイス帯電モデル (C101)
- 制御入力の V_{IH}/V_{IL} レベルは V_{CCA} 電圧を基準
- V_{CC} 絶縁機能: いずれかの V_{CC} 入力が GND レベルになると、すべての出力がハイ・インピーダンス状態に移行
- I_{off} により部分的パワーダウン・モードをサポート
- 完全に構成可能なデュアル・レール設計により、1.4V ~ 3.6V の電源電圧の全範囲にわたって各ポートが動作可能
- 4.6V 許容の I/O
- 最大データ・レート:
 - 170Mbps ($V_{CCA} < 1.8V$ または $V_{CCB} < 1.8V$)
 - 320Mbps ($V_{CCA} \geq 1.8V$ および $V_{CCB} \geq 1.8V$)

2 アプリケーション

- パーソナル・エレクトロニクス
- 産業用
- エンタープライズ
- テレコム

3 概要

この 8 ビット非反転バス・トランシーバは、設定可能な 2 本の独立した電源レールを使用します。SN74AVC8T245 は V_{CCA}/V_{CCB} を 1.4V ~ 3.6V に設定して動作するように最適化されています。本デバイスは最低 1.2V の V_{CCA}/V_{CCB} で動作します。A ポートは V_{CCA} に追従する設計です。 V_{CCA} は 1.2V ~ 3.6V の電源電圧に対応します。B ポートは V_{CCB} に追従する設計です。 V_{CCB} には 1.2V ~ 3.6V の電源電圧に対応します。このため 1.2V、1.5V、1.8V、2.5V、3.3V の任意の電圧ノード間で、低電圧の双方向変換を自在に行うことが可能になります。

SN74AVC8T245 は、データ・バス間の非同期通信用に設計されています。このデバイスは、方向制御 (DIR) 入力の論理レベルに応じて、A バスから B バス、または B バスから A バスへデータを転送します。出力イネーブル (\overline{OE}) 入力を使用すると、出力をディセーブルにして、バスを実質的に絶縁できます。

SN74AVC8T245 は、制御ピン (DIR および \overline{OE}) が V_{CCA} から電源を供給されるように設計されています。

SN74AVC8T245 は単一電源システムと互換性があり、後で '245 機能に置き換えることができ、プリント基板の再設計を最小限に抑えることができます。

このデバイスは、 I_{off} を使った部分的パワーダウン・アプリケーション向けに完全に動作が規定されています。 I_{off} 回路が出力をディセーブルにするため、電源切断時にデバイスに電流が逆流して損傷に至ることを回避できます。

V_{CC} 絶縁機能により、どちらかの V_{CC} 入力が GND レベルになると、両方のポートをハイ・インピーダンス状態にできます。

電源オンまたは電源オフ時にデバイスをハイ・インピーダンス状態にするには、 \overline{OE} をプルアップ抵抗経路で V_{CC} に接続します。この抵抗の最小値は、ドライバの電流シンク能力によって決まります。

パッケージ情報

部品番号	パッケージ (1)	パッケージ・サイズ (2)
SN74AVC8T245	RHL (VQFN, 24)	5.5mm × 3.5mm
	PW (TSSOP, 24)	7.8mm × 6.4mm
	DGV (TVSOP, 24)	5mm × 6.4mm

- (1) 詳細については、[セクション 10](#) を参照してください。
- (2) パッケージ・サイズ (長さ × 幅) は公称値であり、該当する場合はピンも含まれます。

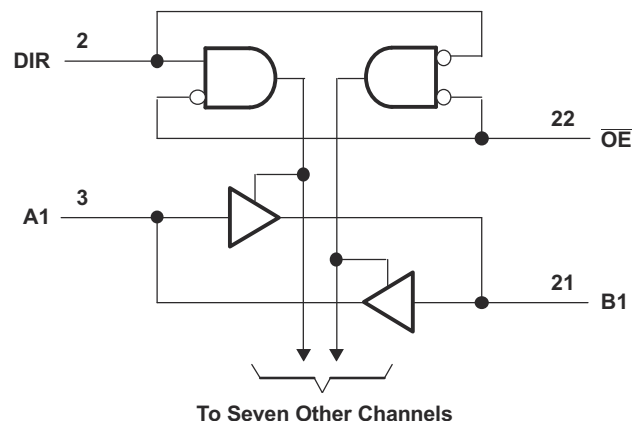

論理図 (正論理)



Table of Contents

1 特長	1	6.1 Overview.....	16
2 アプリケーション	1	6.2 Functional Block Diagram.....	16
3 概要	1	6.3 Feature Description.....	16
4 Pin Configuration and Functions	3	6.4 Device Functional Modes.....	17
5 Specifications	4	7 Application and Implementation	18
5.1 Absolute Maximum Ratings.....	4	7.1 Application Information.....	18
5.2 ESD Ratings.....	4	7.2 Typical Application.....	18
5.3 Recommended Operating Conditions.....	5	7.3 Power Supply Recommendations.....	19
5.4 Thermal Information.....	6	7.4 Layout.....	19
5.5 Electrical Characteristics.....	6	8 Device and Documentation Support	21
5.6 Switching Characteristics, $V_{CCA} = 1.2\text{ V}$	8	8.1 Documentation Support.....	21
5.7 Switching Characteristics, $V_{CCA} = 1.5\text{ V} \pm 0.1\text{ V}$	8	8.2 ドキュメントの更新通知を受け取る方法.....	21
5.8 Switching Characteristics, $V_{CCA} = 1.8\text{ V} \pm 0.15\text{ V}$	9	8.3 サポート・リソース.....	21
5.9 Switching Characteristics, $V_{CCA} = 2.5\text{ V} \pm 0.2\text{ V}$	10	8.4 Trademarks.....	21
5.10 Switching Characteristics, $V_{CCA} = 3.3\text{ V} \pm 0.3\text{ V}$	11	8.5 静電気放電に関する注意事項.....	21
5.11 Operating Characteristics.....	12	8.6 用語集.....	21
5.12 Typical Total Static Power Consumption ($I_{CCA} + I_{CCB}$).....	12	9 Revision History	21
5.13 Typical Characteristics.....	13	10 Mechanical, Packaging, and Orderable Information	22
6 Detailed Description	16		

4 Pin Configuration and Functions



図 4-1. DGV or PW Package, 24-Pin TVSOP or TSSOP (Top View)



図 4-2. RHL Package, 24-Pin VQFN (Top View)

表 4-1. Pin Functions

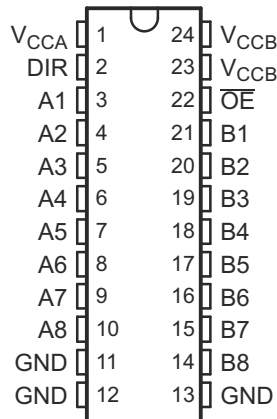
PIN		I/O	DESCRIPTION
NAME	NO.		
A1	3	I/O	Input/output A1. Referenced to V_{CCA} .
A2	4	I/O	Input/output A2. Referenced to V_{CCA} .
A3	5	I/O	Input/output A3. Referenced to V_{CCA} .
A4	6	I/O	Input/output A4. Referenced to V_{CCA} .
A5	7	I/O	Input/output A5. Referenced to V_{CCA} .
A6	8	I/O	Input/output A6. Referenced to V_{CCA} .
A7	9	I/O	Input/output A7. Referenced to V_{CCA} .
A8	10	I/O	Input/output A8. Referenced to V_{CCA} .
B1	21	I/O	Input/output B1. Referenced to V_{CCB} .
B2	20	I/O	Input/output B2. Referenced to V_{CCB} .
B3	19	I/O	Input/output B3. Referenced to V_{CCB} .
B4	18	I/O	Input/output B4. Referenced to V_{CCB} .
B5	17	I/O	Input/output B5. Referenced to V_{CCB} .
B6	16	I/O	Input/output B6. Referenced to V_{CCB} .
B7	15	I/O	Input/output B7. Referenced to V_{CCB} .
B8	14	I/O	Input/output B8. Referenced to V_{CCB} .
DIR	2	I	Direction-control signal
GND	11, 12, 13	—	Ground
\overline{OE}	22	I	3-state output-mode enables. Pull \overline{OE} high to place all outputs in 3-state mode. Referenced to V_{CCA} .
V_{CCA}	1	—	A-port supply voltage. $1.2\text{ V} \leq V_{CCA} \leq 3.6\text{ V}$
V_{CCB}	23, 24	—	B-port supply voltage. $1.2\text{ V} \leq V_{CCB} \leq 3.6\text{ V}$

5 Specifications

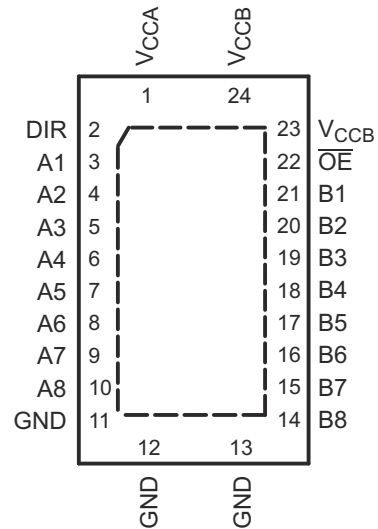
5.1 Absolute Maximum Ratings

over operating free-air temperature range (unless otherwise noted) ⁽¹⁾

		MIN	MAX	UNIT	
V_{CCA} , V_{CCB}	Supply voltage	–0.5	4.6	V	
V_I	Input voltage ⁽²⁾	I/O ports (A port)	–0.5	4.6	V
		I/O ports (B port)	–0.5	4.6	
		Control inputs	–0.5	4.6	
V_O	Voltage range applied to any output in the high-impedance or power-off state ⁽²⁾	A port	–0.5	4.6	V
		B port	–0.5	4.6	
V_O	Voltage range applied to any output in the high or low state ⁽²⁾ ⁽³⁾	A port	–0.5	$V_{CCA} + 0.5$	V
		B port	–0.5	$V_{CCB} + 0.5$	
I_{IK}	Input clamp current	$V_I < 0$	–50	mA	
I_{OK}	Output clamp current	$V_O < 0$	–50	mA	
I_O	Continuous output current		–50	50	mA
	Continuous current through V_{CCA} , V_{CCB} , or GND		–100	100	mA
T_{stg}	Storage temperature		–65	150	°C

- (1) Stresses beyond those listed under *Absolute Maximum Ratings* may cause permanent damage to the device. These are stress ratings only, and functional operation of the device at these or any other conditions beyond those indicated under *Recommended Operating Conditions* is not implied. Exposure to absolute-maximum-rated conditions for extended periods may affect device reliability.
- (2) The input voltage and output negative-voltage ratings may be exceeded if the input and output current ratings are observed.
- (3) The output positive-voltage rating may be exceeded up to 4.6 V maximum if the output current rating is observed.

5.2 ESD Ratings

		VALUE	UNIT	
$V_{(ESD)}$	Electrostatic discharge	Human-body model (HBM), per ANSI/ESDA/JEDEC JS-001 ⁽¹⁾	±8000	V
		Charged-device model (CDM), per JEDEC specification JESD22-C101 ⁽²⁾	±1000	
		Machine model (MM)	±200	

- (1) JEDEC document JEP155 states that 500-V HBM allows safe manufacturing with a standard ESD control process.
- (2) JEDEC document JEP157 states that 250-V CDM allows safe manufacturing with a standard ESD control process.

5.3 Recommended Operating Conditions

See (1) (2) (3)

		V_{CCI}	V_{CCO}	MIN	MAX	UNIT
V_{CCA}	Supply voltage			1.2	3.6	V
V_{CCB}	Supply voltage			1.2	3.6	V
V_{IH}	High-level input voltage	Data inputs	1.2 V to 1.95 V	$V_{CCI} \times 0.65$		V
			1.95 V to 2.7 V	1.6		
			2.7 V to 3.6 V	2		
V_{IL}	Low-level input voltage	Data inputs	1.2 V to 1.95 V	$V_{CCI} \times 0.35$		V
			1.95 V to 2.7 V	0.7		
			2.7 V to 3.6 V	0.8		
V_{IH}	High-level input voltage	DIR (referenced to V_{CCA})	1.2 V to 1.95 V	$V_{CCA} \times 0.65$		V
			1.95 V to 2.7 V	1.6		
			2.7 V to 3.6 V	2		
V_{IL}	Low-level input voltage	DIR (referenced to V_{CCA})	1.2 V to 1.95 V	$V_{CCA} \times 0.35$		V
			1.95 V to 2.7 V	0.7		
			2.7 V to 3.6 V	0.8		
V_I	Input voltage			0	3.6	V
V_O	Output voltage	Active state		0	V_{CCO}	V
		3-state		0	3.6	
I_{OH}	High-level output current		1.2 V	-3		mA
			1.4 V to 1.6 V	-6		
			1.65 V to 1.95 V	-8		
			2.3 V to 2.7 V	-9		
			3 V to 3.6 V	-12		
I_{OL}	Low-level output current		1.2 V	3		mA
			1.4 V to 1.6 V	6		
			1.65 V to 1.95 V	8		
			2.3 V to 2.7 V	9		
			3 V to 3.6 V	12		
$\Delta t/\Delta v$	Input transition rise or fall rate				5	ns/V
T_A	Operating free-air temperature			-40	125	°C

- (1) V_{CCI} is the V_{CC} associated with the input port.
- (2) V_{CCO} is the V_{CC} associated with the output port.
- (3) All unused data inputs of the device must be held at V_{CCI} or GND to ensure proper device operation. See [Implications of Slow or Floating CMOS Inputs](#), SCBA004.

5.4 Thermal Information

THERMAL METRIC ⁽¹⁾		SN74AVC8T245			UNIT
		DGV	PW	RHL	
		24 PINS	24 PINS	24 PINS	
R _{θJA}	Junction-to-ambient thermal resistance	116.7	93.1	36.8	°C/W
R _{θJC(top)}	Junction-to-case (top) thermal resistance	48.5	36.7	32.5	°C/W
R _{θJB}	Junction-to-board thermal resistance	62.1	48.4	15.7	°C/W
Ψ _{JT}	Junction-to-top characterization parameter	7.0	93.1	0.7	°C/W
Ψ _{JB}	Junction-to-board characterization parameter	61.6	48.0	15.6	°C/W
R _{θJC(bot)}	Junction-to-case (bottom) thermal resistance	N/A	N/A	5.6	°C/W

(1) For more information about traditional and new thermal metrics, see the [Semiconductor and IC Package Thermal Metrics](#) application report.

5.5 Electrical Characteristics

over recommended operating free-air temperature range (unless otherwise noted)⁽²⁾ (1)

PARAMETER	TEST CONDITIONS	V _{CCA}	V _{CCB}	T _A = 25°C			-40°C to +85°C		-40°C to +125°C		UNIT
				MIN	TYP	MAX	MIN	MAX	MIN	MAX	
V _{OH}	I _{OH} = -100 μA	V _I = V _{IH}	1.2 V to 3.6 V	1.2 V to 3.6 V			V _{CCO} - 0.2	V _{CCO} - 0.2		V	
	I _{OH} = -3 mA		1.2 V	1.2 V	0.95						
	I _{OH} = -6 mA		1.4 V	1.4 V		1.05	1				
	I _{OH} = -8 mA		1.65 V	1.65 V		1.2	1.2				
	I _{OH} = -9 mA		2.3 V	2.3 V		1.75	1.75				
	I _{OH} = -12 mA		3 V	3 V		2.3	2.3				
V _{OL}	I _{OL} = 100 μA	V _I = V _{IL}	1.2 V to 3.6 V	1.2 V to 3.6 V			0.2	0.2		V	
	I _{OL} = 3 mA		1.2 V	1.2 V	0.15						
	I _{OL} = 6 mA		1.4 V	1.4 V		0.35	0.35				
	I _{OL} = 8 mA		1.65 V	1.65 V		0.45	0.45				
	I _{OL} = 9 mA		2.3 V	2.3 V		0.55	0.55				
	I _{OL} = 12 mA		3 V	3 V		0.7	0.7				
I _I Control inputs	V _I = V _{CCA} or GND	1.2 V to 3.6 V	1.2 V to 3.6 V	-0.25	±0.025	0.25	-1	1	±1	μA	
I _{off} A or B port	V _I or V _O = 0 to 3.6 V	0 V	0 V to 3.6 V	-1	±0.1	1	-5	5	±5	μA	
		0 V to 3.6 V	0 V	-1	±0.1	1	-5	5	±5		
I _{OZ} (3) A or B port	V _O = V _{CCO} or GND, V _I = V _{CC1} or GND, OE = V _{IH}	3.6 V	3.6 V		±0.5	±2.5		±5	±5	μA	
I _{CCA}	V _I = V _{CC1} or GND, I _O = 0	1.2 V to 3.6 V	1.2 V to 3.6 V				15	15		μA	
		0 V	3.6 V				-2	-2			
		3.6 V	0 V				15	15			
I _{CCB}	V _I = V _{CC1} or GND, I _O = 0	1.2 V to 3.6 V	1.2 V to 3.6 V				15	15		μA	
		0 V	3.6 V				15	15			
		3.6 V	0 V				-2	-2			
I _{CCA} + I _{CCB}	V _I = V _{CC1} or GND, I _O = 0	1.2 V to 3.6 V	1.2 V to 3.6 V				25	25		μA	
C _i Control inputs	V _I = 3.3 V or GND	3.3 V	3.3 V		3.5		4.5			pF	
C _{io} A or B port	V _O = 3.3 V or GND	3.3 V	3.3 V		6		7			pF	

(1) V_{CC1} is the V_{CC} associated with the input port.

(2) V_{CCO} is the V_{CC} associated with the output port.

- (3) For I/O ports, the parameter I_{OZ} includes the input leakage current.

5.6 Switching Characteristics, $V_{CCA} = 1.2\text{ V}$

over recommended operating free-air temperature range, $V_{CCA} = 1.2\text{ V}$ (see [Figure 6-1](#))

PARAMETER	FROM (INPUT)	TO (OUTPUT)	V_{CCB}	$T_A = -40^\circ\text{C to } +85^\circ\text{C}$		$T_A = -40^\circ\text{C to } +125^\circ\text{C}$		UNIT
				TYP		TYP		
t_{PLH}, t_{PHL}	A	B	$V_{CCB} = 1.2\text{ V}$	3.1		3.1		ns
			$V_{CCB} = 1.5\text{ V}$	2.6		2.6		
			$V_{CCB} = 1.8\text{ V}$	2.5		2.5		
			$V_{CCB} = 2.5\text{ V}$	3		3		
			$V_{CCB} = 3.3\text{ V}$	3.5		3.5		
t_{PLH}, t_{PHL}	B	A	$V_{CCB} = 1.2\text{ V}$	3.1		3.1		ns
			$V_{CCB} = 1.5\text{ V}$	2.7		2.7		
			$V_{CCB} = 1.8\text{ V}$	2.5		2.5		
			$V_{CCB} = 2.5\text{ V}$	2.4		2.4		
			$V_{CCB} = 3.3\text{ V}$	2.3		2.3		
t_{PZH}, t_{PZL}	OE	A	$V_{CCB} = 1.2\text{ V}$	5.3		5.3		ns
			$V_{CCB} = 1.5\text{ V}$					
			$V_{CCB} = 1.8\text{ V}$					
			$V_{CCB} = 2.5\text{ V}$					
			$V_{CCB} = 3.3\text{ V}$					
t_{PZH}, t_{PZL}	OE	B	$V_{CCB} = 1.2\text{ V}$	5.1		5.1		ns
			$V_{CCB} = 1.5\text{ V}$	4		4		
			$V_{CCB} = 1.8\text{ V}$	3.5		3.5		
			$V_{CCB} = 2.5\text{ V}$	3.2		3.2		
			$V_{CCB} = 3.3\text{ V}$	3.1		3.1		
t_{PHZ}, t_{PLZ}	OE	A	$V_{CCB} = 1.2\text{ V}$	4.8		4.8		ns
			$V_{CCB} = 1.5\text{ V}$					
			$V_{CCB} = 1.8\text{ V}$					
			$V_{CCB} = 2.5\text{ V}$					
			$V_{CCB} = 3.3\text{ V}$					
t_{PHZ}, t_{PLZ}	OE	B	$V_{CCB} = 1.2\text{ V}$	4.7		4.7		ns
			$V_{CCB} = 1.5\text{ V}$	4		4		
			$V_{CCB} = 1.8\text{ V}$	4.1		4.1		
			$V_{CCB} = 2.5\text{ V}$	4.3		4.3		
			$V_{CCB} = 3.3\text{ V}$	5.1		5.1		

5.7 Switching Characteristics, $V_{CCA} = 1.5\text{ V} \pm 0.1\text{ V}$

over recommended operating free-air temperature range, $V_{CCA} = 1.5\text{ V} \pm 0.1\text{ V}$ (see [Figure 6-1](#))

PARAMETER	FROM (INPUT)	TO (OUTPUT)	V_{CCB}	$T_A = -40^\circ\text{C to } +85^\circ\text{C}$			$T_A = -40^\circ\text{C to } +125^\circ\text{C}$			UNIT
				MIN	TYP	MAX	MIN	TYP	MAX	
t_{PLH}, t_{PHL}	A	B	$V_{CCB} = 1.2\text{ V}$	2.7			3.1			ns
			$V_{CCB} = 1.5\text{ V} \pm 0.1\text{ V}$	0.5		5.4	0.5		14.7	
			$V_{CCB} = 1.8\text{ V} \pm 0.15\text{ V}$	0.5		4.6	0.5		13.3	
			$V_{CCB} = 2.5\text{ V} \pm 0.2\text{ V}$	0.5		4.9	0.5		13.9	
			$V_{CCB} = 3.3\text{ V} \pm 0.3\text{ V}$	0.5		6.8	0.5		17.2	

5.7 Switching Characteristics, $V_{CCA} = 1.5\text{ V} \pm 0.1\text{ V}$ (続き)

over recommended operating free-air temperature range, $V_{CCA} = 1.5\text{ V} \pm 0.1\text{ V}$ (see [図 6-1](#))

PARAMETER	FROM (INPUT)	TO (OUTPUT)	V_{CCB}	$T_A = -40^\circ\text{C to } +85^\circ\text{C}$			$T_A = -40^\circ\text{C to } +125^\circ\text{C}$			UNIT
				MIN	TYP	MAX	MIN	TYP	MAX	
t_{PLH}, t_{PHL}	B	A	$V_{CCB} = 1.2\text{ V}$	2.6			3.1			ns
			$V_{CCB} = 1.5\text{ V} \pm 0.1\text{ V}$	0.5	5.4		0.5	14.7		
			$V_{CCB} = 1.8\text{ V} \pm 0.15\text{ V}$	0.5	5.1		0.5	14.2		
			$V_{CCB} = 2.5\text{ V} \pm 0.2\text{ V}$	0.5	4.7		0.5	13.5		
			$V_{CCB} = 3.3\text{ V} \pm 0.3\text{ V}$	0.5	4.5		0.5	13.2		
t_{PZH}, t_{PZL}	$\overline{\text{OE}}$	A	$V_{CCB} = 1.2\text{ V}$	3.7			5.3			ns
			$V_{CCB} = 1.5\text{ V} \pm 0.1\text{ V}$	1.1	8.7		0.5	20.5		
			$V_{CCB} = 1.8\text{ V} \pm 0.15\text{ V}$	1.1	8.7		0.5	20.5		
			$V_{CCB} = 2.5\text{ V} \pm 0.2\text{ V}$	1.1	8.7		0.5	20.5		
			$V_{CCB} = 3.3\text{ V} \pm 0.3\text{ V}$	1.1	8.7		0.5	20.5		
t_{PZH}, t_{PZL}	$\overline{\text{OE}}$	B	$V_{CCB} = 1.2\text{ V}$	4.8			5.1			ns
			$V_{CCB} = 1.5\text{ V} \pm 0.1\text{ V}$	1.1	7.6		0.5	18.6		
			$V_{CCB} = 1.8\text{ V} \pm 0.15\text{ V}$	1.1	7.1		0.5	17.7		
			$V_{CCB} = 2.5\text{ V} \pm 0.2\text{ V}$	1	5.6		0.5	15.1		
			$V_{CCB} = 3.3\text{ V} \pm 0.3\text{ V}$	1	5.2		0.5	14.4		
t_{PHZ}, t_{PLZ}	$\overline{\text{OE}}$	A	$V_{CCB} = 1.2\text{ V}$	3.1			4.8			ns
			$V_{CCB} = 1.5\text{ V} \pm 0.1\text{ V}$	0.5	8.6		0.5	20.3		
			$V_{CCB} = 1.8\text{ V} \pm 0.15\text{ V}$	0.5	8.6		0.5	20.3		
			$V_{CCB} = 2.5\text{ V} \pm 0.2\text{ V}$	0.5	8.6		0.5	20.3		
			$V_{CCB} = 3.3\text{ V} \pm 0.3\text{ V}$	0.5	8.6		0.5	20.3		
t_{PHZ}, t_{PLZ}	$\overline{\text{OE}}$	B	$V_{CCB} = 1.2\text{ V}$	4.1			4.7			ns
			$V_{CCB} = 1.5\text{ V} \pm 0.1\text{ V}$	0.5	8.4		0.5	20		
			$V_{CCB} = 1.8\text{ V} \pm 0.15\text{ V}$	0.5	7.6		0.5	18.6		
			$V_{CCB} = 2.5\text{ V} \pm 0.2\text{ V}$	0.5	7.2		0.5	17.9		
			$V_{CCB} = 3.3\text{ V} \pm 0.3\text{ V}$	0.5	7.8		0.5	18.9		

5.8 Switching Characteristics, $V_{CCA} = 1.8\text{ V} \pm 0.15\text{ V}$

over recommended operating free-air temperature range, $V_{CCA} = 1.8\text{ V} \pm 0.15\text{ V}$ (see [図 6-1](#))

PARAMETER	FROM (INPUT)	TO (OUTPUT)	V_{CCB}	$T_A = -40^\circ\text{C to } +85^\circ\text{C}$			$T_A = -40^\circ\text{C to } +125^\circ\text{C}$			UNIT
				MIN	TYP	MAX	MIN	TYP	MAX	
t_{PLH}, t_{PHL}	A	B	$V_{CCB} = 1.2\text{ V}$	2.5			2.5			ns
			$V_{CCB} = 1.5\text{ V} \pm 0.1\text{ V}$	0.5	5.1		0.5	14.2		
			$V_{CCB} = 1.8\text{ V} \pm 0.15\text{ V}$	0.5	4.4		0.5	13		
			$V_{CCB} = 2.5\text{ V} \pm 0.2\text{ V}$	0.5	4		0.5	12.3		
			$V_{CCB} = 3.3\text{ V} \pm 0.3\text{ V}$	0.5	3.9		0.5	12.1		
t_{PLH}, t_{PHL}	B	A	$V_{CCB} = 1.2\text{ V}$	2.5			2.5			ns
			$V_{CCB} = 1.5\text{ V} \pm 0.1\text{ V}$	0.5	4.6		0.5	13.3		
			$V_{CCB} = 1.8\text{ V} \pm 0.15\text{ V}$	0.5	4.4		0.5	13		
			$V_{CCB} = 2.5\text{ V} \pm 0.2\text{ V}$	0.5	3.9		0.5	12.1		
			$V_{CCB} = 3.3\text{ V} \pm 0.3\text{ V}$	0.5	3.7		0.5	11.8		

5.8 Switching Characteristics, $V_{CCA} = 1.8\text{ V} \pm 0.15\text{ V}$ (続き)

over recommended operating free-air temperature range, $V_{CCA} = 1.8\text{ V} \pm 0.15\text{ V}$ (see [Figure 6-1](#))

PARAMETER	FROM (INPUT)	TO (OUTPUT)	V_{CCB}	$T_A = -40^\circ\text{C to } +85^\circ\text{C}$			$T_A = -40^\circ\text{C to } +125^\circ\text{C}$			UNIT
				MIN	TYP	MAX	MIN	TYP	MAX	
t_{PZH}, t_{PZL}	$\overline{\text{OE}}$	A	$V_{CCB} = 1.2\text{ V}$	3			3			ns
			$V_{CCB} = 1.5\text{ V} \pm 0.1\text{ V}$	1		6.8	0.5		17.2	
			$V_{CCB} = 1.8\text{ V} \pm 0.15\text{ V}$	1		6.8	0.5		17.2	
			$V_{CCB} = 2.5\text{ V} \pm 0.2\text{ V}$	1		6.8	0.5		17.2	
			$V_{CCB} = 3.3\text{ V} \pm 0.3\text{ V}$	1		6.8	0.5		17.2	
t_{PZH}, t_{PZL}	$\overline{\text{OE}}$	B	$V_{CCB} = 1.2\text{ V}$	4.6			4.6			ns
			$V_{CCB} = 1.5\text{ V} \pm 0.1\text{ V}$	1.1		8.2	0.5		19.6	
			$V_{CCB} = 1.8\text{ V} \pm 0.15\text{ V}$	1		6.7	0.5		17	
			$V_{CCB} = 2.5\text{ V} \pm 0.2\text{ V}$	0.5		5.1	0.5		14.2	
			$V_{CCB} = 3.3\text{ V} \pm 0.3\text{ V}$	0.5		4.5	0.5		13.2	
t_{PHZ}, t_{PLZ}	$\overline{\text{OE}}$	A	$V_{CCB} = 1.2\text{ V}$	2.8			2.8			ns
			$V_{CCB} = 1.5\text{ V} \pm 0.1\text{ V}$	0.5		7.1	0.5		17.7	
			$V_{CCB} = 1.8\text{ V} \pm 0.15\text{ V}$	0.5		7.1	0.5		17.7	
			$V_{CCB} = 2.5\text{ V} \pm 0.2\text{ V}$	0.5		7.1	0.5		17.7	
			$V_{CCB} = 3.3\text{ V} \pm 0.3\text{ V}$	0.5		7.1	0.5		17.7	
t_{PHZ}, t_{PLZ}	$\overline{\text{OE}}$	B	$V_{CCB} = 1.2\text{ V}$	3.9			3.9			ns
			$V_{CCB} = 1.5\text{ V} \pm 0.1\text{ V}$	0.5		7.8	0.5		18.9	
			$V_{CCB} = 1.8\text{ V} \pm 0.15\text{ V}$	0.5		6.9	0.5		17.3	
			$V_{CCB} = 2.5\text{ V} \pm 0.2\text{ V}$	0.5		6	0.5		15.8	
			$V_{CCB} = 3.3\text{ V} \pm 0.3\text{ V}$	0.5		5.8	0.5		15.4	

5.9 Switching Characteristics, $V_{CCA} = 2.5\text{ V} \pm 0.2\text{ V}$

over recommended operating free-air temperature range, $V_{CCA} = 2.5\text{ V} \pm 0.2\text{ V}$ (see [Figure 6-1](#))

PARAMETER	FROM (INPUT)	TO (OUTPUT)	V_{CCB}	$T_A = -40^\circ\text{C to } +85^\circ\text{C}$			$T_A = -40^\circ\text{C to } +125^\circ\text{C}$			UNIT
				MIN	TYP	MAX	MIN	TYP	MAX	
t_{PLH}, t_{PHL}	A	B	$V_{CCB} = 1.2\text{ V}$	2.4			2.4			ns
			$V_{CCB} = 1.5\text{ V} \pm 0.1\text{ V}$	0.5		4.7	0.5		13.5	
			$V_{CCB} = 1.8\text{ V} \pm 0.15\text{ V}$	0.5		3.9	0.5		12.1	
			$V_{CCB} = 2.5\text{ V} \pm 0.2\text{ V}$	0.5		3.1	0.5		10.7	
			$V_{CCB} = 3.3\text{ V} \pm 0.3\text{ V}$	0.5		2.8	0.5		10.2	
t_{PLH}, t_{PHL}	B	A	$V_{CCB} = 1.2\text{ V}$	3			3			ns
			$V_{CCB} = 1.5\text{ V} \pm 0.1\text{ V}$	0.5		4.9	0.5		13.9	
			$V_{CCB} = 1.8\text{ V} \pm 0.15\text{ V}$	0.5		4	0.5		12.3	
			$V_{CCB} = 2.5\text{ V} \pm 0.2\text{ V}$	0.5		3.1	0.5		10.7	
			$V_{CCB} = 3.3\text{ V} \pm 0.3\text{ V}$	0.5		2.9	0.5		10.4	
t_{PZH}, t_{PZL}	$\overline{\text{OE}}$	A	$V_{CCB} = 1.2\text{ V}$	2.2			2.2			ns
			$V_{CCB} = 1.5\text{ V} \pm 0.1\text{ V}$	0.5		4.8	0.5		13.7	
			$V_{CCB} = 1.8\text{ V} \pm 0.15\text{ V}$	0.5		4.8	0.5		13.7	
			$V_{CCB} = 2.5\text{ V} \pm 0.2\text{ V}$	0.5		4.8	0.5		13.7	
			$V_{CCB} = 3.3\text{ V} \pm 0.3\text{ V}$	0.5		4.8	0.5		13.7	

5.9 Switching Characteristics, $V_{CCA} = 2.5\text{ V} \pm 0.2\text{ V}$ (続き)

over recommended operating free-air temperature range, $V_{CCA} = 2.5\text{ V} \pm 0.2\text{ V}$ (see 図 6-1)

PARAMETER	FROM (INPUT)	TO (OUTPUT)	V_{CCB}	$T_A = -40^\circ\text{C to } +85^\circ\text{C}$			$T_A = -40^\circ\text{C to } +125^\circ\text{C}$			UNIT
				MIN	TYP	MAX	MIN	TYP	MAX	
t_{PZH}, t_{PZL}	$\overline{\text{OE}}$	B	$V_{CCB} = 1.2\text{ V}$	4.5			4.5			ns
			$V_{CCB} = 1.5\text{ V} \pm 0.1\text{ V}$	1.1		7.9	0.5		19.1	
			$V_{CCB} = 1.8\text{ V} \pm 0.15\text{ V}$	0.5		6.4	0.5		16.5	
			$V_{CCB} = 2.5\text{ V} \pm 0.2\text{ V}$	0.5		4.6	0.5		13.3	
			$V_{CCB} = 3.3\text{ V} \pm 0.3\text{ V}$	0.5		4	0.5		12.3	
t_{PHZ}, t_{PLZ}	$\overline{\text{OE}}$	A	$V_{CCB} = 1.2\text{ V}$	1.8			1.8			ns
			$V_{CCB} = 1.5\text{ V} \pm 0.1\text{ V}$	0.5		5.1	0.5		14.2	
			$V_{CCB} = 1.8\text{ V} \pm 0.15\text{ V}$	0.5		5.1	0.5		14.2	
			$V_{CCB} = 2.5\text{ V} \pm 0.2\text{ V}$	0.5		5.1	0.5		14.2	
			$V_{CCB} = 3.3\text{ V} \pm 0.3\text{ V}$	0.5		5.1	0.5		14.2	
t_{PHZ}, t_{PLZ}	$\overline{\text{OE}}$	B	$V_{CCB} = 1.2\text{ V}$	3.6			3.6			ns
			$V_{CCB} = 1.5\text{ V} \pm 0.1\text{ V}$	0.5		7.1	0.5		17.7	
			$V_{CCB} = 1.8\text{ V} \pm 0.15\text{ V}$	0.5		6.3	0.5		16.3	
			$V_{CCB} = 2.5\text{ V} \pm 0.2\text{ V}$	0.5		5.1	0.5		14.2	
			$V_{CCB} = 3.3\text{ V} \pm 0.3\text{ V}$	0.5		3.9	0.5		12.1	

5.10 Switching Characteristics, $V_{CCA} = 3.3\text{ V} \pm 0.3\text{ V}$

over recommended operating free-air temperature range, $V_{CCA} = 3.3\text{ V} \pm 0.3\text{ V}$ (see 図 6-1)

PARAMETER	FROM (INPUT)	TO (OUTPUT)	V_{CCB}	$T_A = -40^\circ\text{C to } +85^\circ\text{C}$			$T_A = -40^\circ\text{C to } +125^\circ\text{C}$			UNIT	
				MIN	TYP	MAX	MIN	TYP	MAX		
t_{PLH}, t_{PHL}	A	B	$V_{CCB} = 1.2\text{ V}$	2.3			2.3			ns	
			$V_{CCB} = 1.5\text{ V} \pm 0.1\text{ V}$	0.5		4.5	0.5		13.2		
			$V_{CCB} = 1.8\text{ V} \pm 0.15\text{ V}$	t_{PLH}	0.5		3.7	0.5			11.1
				t_{PHL}	0.5		3.3	0.5			11.1
			$V_{CCB} = 2.5\text{ V} \pm 0.2\text{ V}$	0.5		2.9	0.5		10.4		
			$V_{CCB} = 3.3\text{ V} \pm 0.3\text{ V}$	0.5		2.5	0.5		9.7		
t_{PLH}, t_{PHL}	B	A	$V_{CCB} = 1.2\text{ V}$	3.5			3.5			ns	
			$V_{CCB} = 1.5\text{ V} \pm 0.1\text{ V}$	0.5		6.8	0.5		17.2		
			$V_{CCB} = 1.8\text{ V} \pm 0.15\text{ V}$	0.5		3.9	0.5		12.1		
			$V_{CCB} = 2.5\text{ V} \pm 0.2\text{ V}$	0.5		2.8	0.5		10.2		
			$V_{CCB} = 3.3\text{ V} \pm 0.3\text{ V}$	0.5		2.5	0.5		9.7		
t_{PZH}, t_{PZL}	$\overline{\text{OE}}$	A	$V_{CCB} = 1.2\text{ V}$	2			2			ns	
			$V_{CCB} = 1.5\text{ V} \pm 0.1\text{ V}$	0.5		4	0.5		12.3		
			$V_{CCB} = 1.8\text{ V} \pm 0.15\text{ V}$	0.5		4	0.5		12.3		
			$V_{CCB} = 2.5\text{ V} \pm 0.2\text{ V}$	0.5		4	0.5		12.3		
			$V_{CCB} = 3.3\text{ V} \pm 0.3\text{ V}$	0.5		4	0.5		12.3		
t_{PZH}, t_{PZL}	$\overline{\text{OE}}$	B	$V_{CCB} = 1.2\text{ V}$	4.5			4.5			ns	
			$V_{CCB} = 1.5\text{ V} \pm 0.1\text{ V}$	1.1		7.8	0.5		18.9		
			$V_{CCB} = 1.8\text{ V} \pm 0.15\text{ V}$	0.5		6.2	0.5		16.1		
			$V_{CCB} = 2.5\text{ V} \pm 0.2\text{ V}$	0.5		4.5	0.5		13.2		
			$V_{CCB} = 3.3\text{ V} \pm 0.3\text{ V}$	0.5		3.9	0.5		12.3		

5.10 Switching Characteristics, $V_{CCA} = 3.3\text{ V} \pm 0.3\text{ V}$ (続き)

over recommended operating free-air temperature range, $V_{CCA} = 3.3\text{ V} \pm 0.3\text{ V}$ (see [Figure 6-1](#))

PARAMETER	FROM (INPUT)	TO (OUTPUT)	V_{CCB}	$T_A = -40^\circ\text{C to } +85^\circ\text{C}$			$T_A = -40^\circ\text{C to } +125^\circ\text{C}$			UNIT
				MIN	TYP	MAX	MIN	TYP	MAX	
t_{PHZ}, t_{PLZ}	\overline{OE}	A	$V_{CCB} = 1.2\text{ V}$	1.7			1.7			ns
			$V_{CCB} = 1.5\text{ V} \pm 0.1\text{ V}$	0.5		4	0.5		12.3	
			$V_{CCB} = 1.8\text{ V} \pm 0.15\text{ V}$	0.5		4	0.5		12.3	
			$V_{CCB} = 2.5\text{ V} \pm 0.2\text{ V}$	0.5		4	0.5		12.3	
			$V_{CCB} = 3.3\text{ V} \pm 0.3\text{ V}$	0.5		4	0.5		12.3	
t_{PHZ}, t_{PLZ}	\overline{OE}	B	$V_{CCB} = 1.2\text{ V}$	3.4			3.4			ns
			$V_{CCB} = 1.5\text{ V} \pm 0.1\text{ V}$	0.5		6.9	0.5		17.4	
			$V_{CCB} = 1.8\text{ V} \pm 0.15\text{ V}$	0.5		6	0.5		15.8	
			$V_{CCB} = 2.5\text{ V} \pm 0.2\text{ V}$	0.5		4.8	0.5		13.7	
			$V_{CCB} = 3.3\text{ V} \pm 0.3\text{ V}$	0.5		4.2	0.5		12.6	

5.11 Operating Characteristics

$T_A = 25^\circ\text{C}$

PARAMETER		TEST CONDITIONS	$V_{CCA} =$ $V_{CCB} = 1.2\text{ V}$	$V_{CCA} =$ $V_{CCB} = 1.5\text{ V}$	$V_{CCA} =$ $V_{CCB} = 1.8\text{ V}$	$V_{CCA} =$ $V_{CCB} = 2.5\text{ V}$	$V_{CCA} =$ $V_{CCB} = 3.3\text{ V}$	UNIT
			TYP	TYP	TYP	TYP	TYP	
C_{pdA} ⁽¹⁾	A to B	Outputs enabled	1	1	1	1	1	pF
		Outputs disabled	1	1	1	1	1	
	B to A	Outputs enabled	12	12	12	13	14	
		Outputs disabled	1	1	1	1	1	
C_{pdB} ⁽¹⁾	A to B	Outputs enabled	12	12	12	13	14	pF
		Outputs disabled	1	1	1	1	1	
	B to A	Outputs enabled	1	1	1	1	1	
		Outputs disabled	1	1	1	1	1	

(1) Power dissipation capacitance per transceiver

5.12 Typical Total Static Power Consumption ($I_{CCA} + I_{CCB}$)

V_{CCB}	V_{CCA}						UNIT
	0 V	1.2 V	1.5 V	1.8 V	2.5 V	3.3 V	
0 V	0	<0.5	<0.5	<0.5	<0.5	<0.5	μA
1.2 V	<0.5	<1	<1	<1	<1	1	
1.5 V	<0.5	<1	<1	<1	<1	1	
1.8 V	<0.5	<1	<1	<1	<1	<1	
2.5 V	<0.5	1	<1	<1	<1	<1	
3.3 V	<0.5	1	<1	<1	<1	<1	

5.13 Typical Characteristics

$T_A = 25^\circ\text{C}$



图 5-1. Typical Propagation Delay (A to B) vs Load Capacitance



图 5-2. Typical Propagation Delay (A to B) vs Load Capacitance

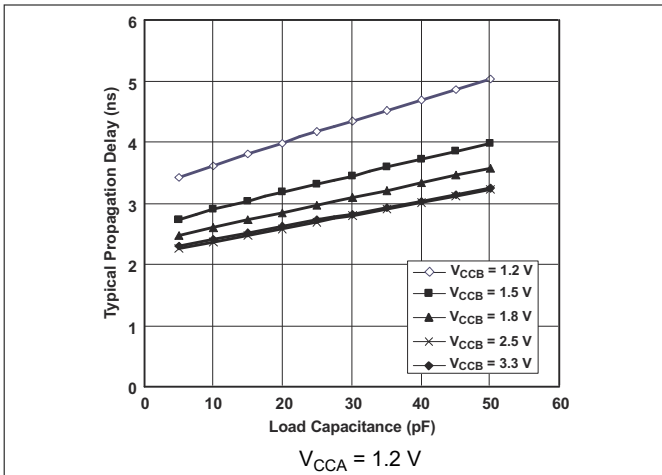

图 5-3. Typical Propagation Delay (A to B) vs Load Capacitance

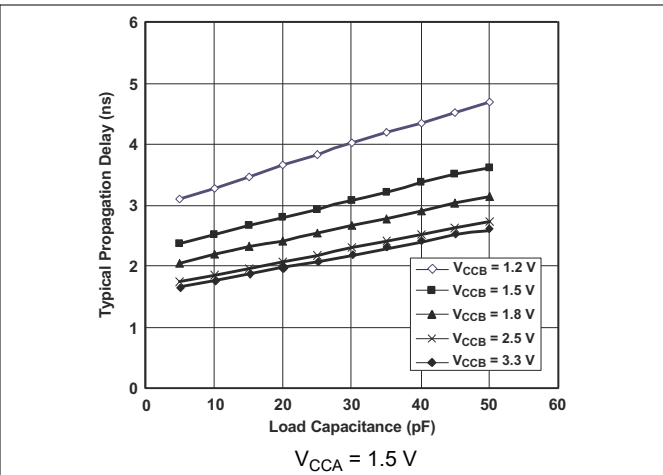

图 5-4. Typical Propagation Delay (A to B) vs Load Capacitance

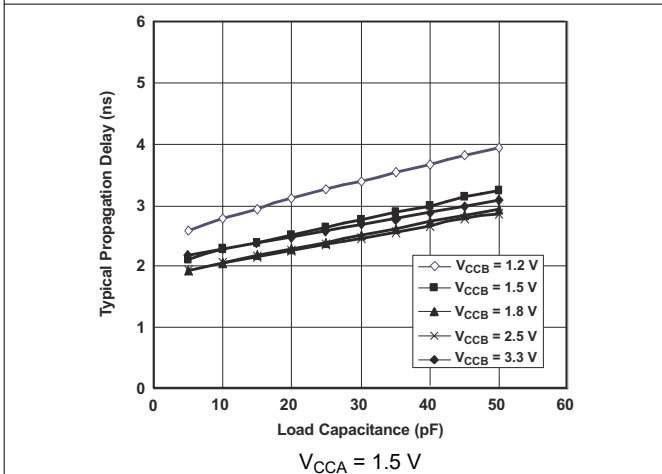

图 5-5. Typical Propagation Delay (A to B) vs Load Capacitance

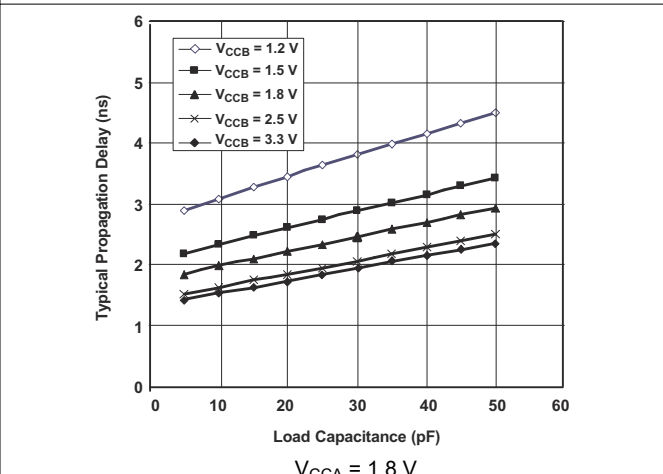

图 5-6. Typical Propagation Delay (A to B) vs Load Capacitance

5.13 Typical Characteristics (continued)

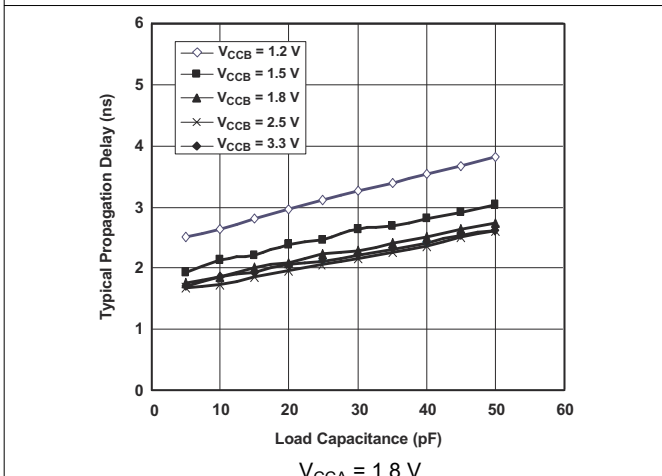
T_A = 25°C

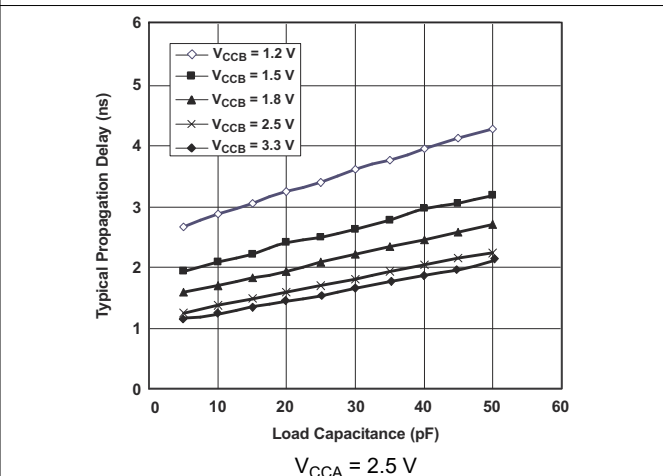

图 5-7. Typical Propagation Delay (A to B) vs Load Capacitance



图 5-8. Typical Propagation Delay (A to B) vs Load Capacitance

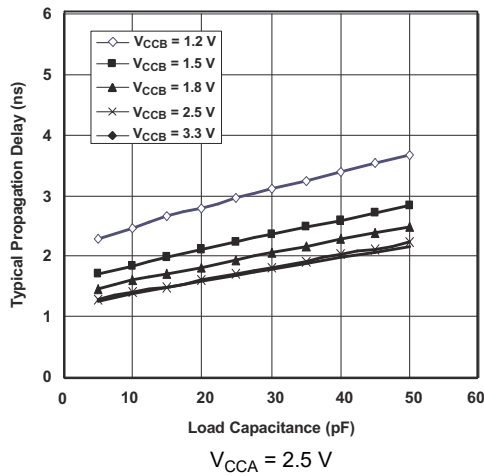

图 5-9. Typical Propagation Delay (A to B) vs Load Capacitance

Parameter Measurement Information

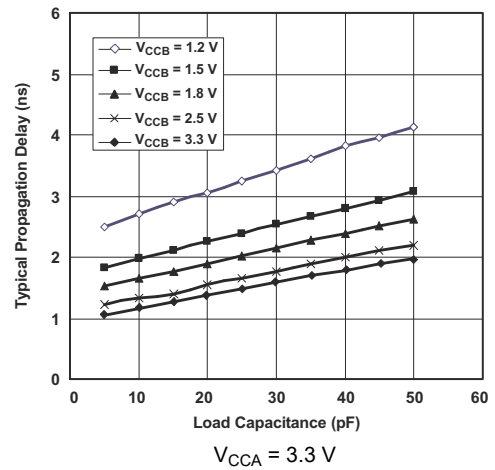

LOAD CIRCUIT

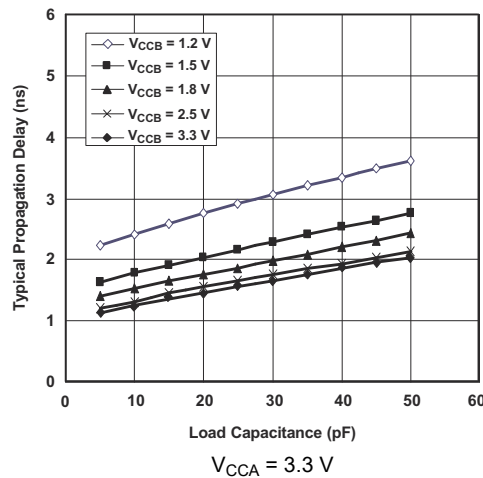
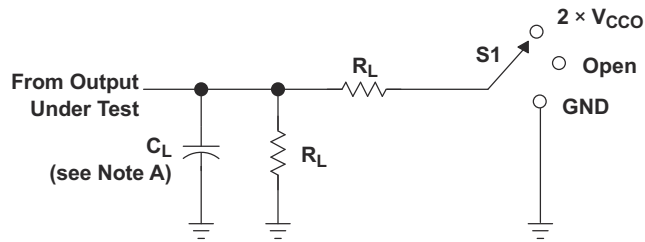
V_{CCO}	C_L	R_L	V_{TP}
1.2 V	15 pF	2 kW	0.1 V
1.5 V ± 0.1 V	15 pF	2 kW	0.1 V
1.8 V ± 0.15 V	15 pF	2 kW	0.15 V
2.5 V ± 0.2 V	15 pF	2 kW	0.15 V
3.3 V ± 0.3 V	15 pF	2 kW	0.3 V

TEST	S1
t_{pd}	Open
t_{PLZ}/t_{PZL}	$2 \times V_{CCO}$
t_{PHZ}/t_{PZH}	GND

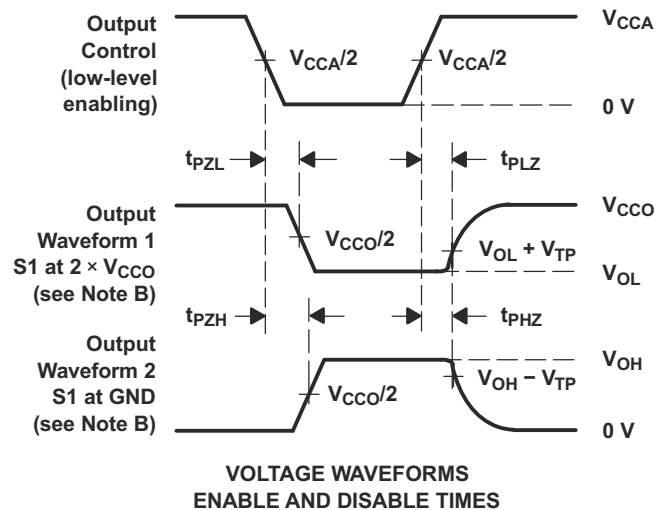
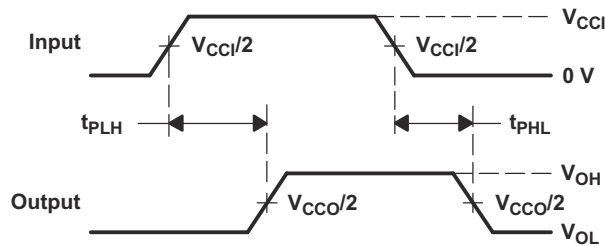
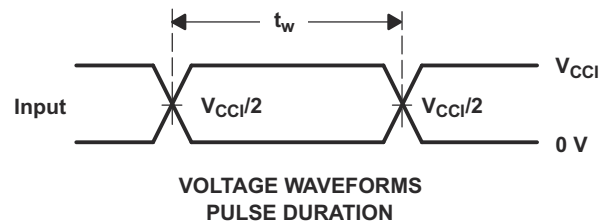

- NOTES:
- C_L includes probe and jig capacitance.
 - Waveform 1 is for an output with internal conditions such that the output is low except when disabled by the output control. Waveform 2 is for an output with internal conditions such that the output is high, except when disabled by the output control.
 - All input pulses are supplied by generators having the following characteristics: PRR = 10 MHz, $Z_O = 50 \Omega$, $dv/dt \geq 1$ V/ns.
 - The outputs are measured one at a time, with one transition per measurement.
 - t_{PLZ} and t_{PHZ} are the same as t_{dis} .
 - t_{PZL} and t_{PZH} are the same as t_{en} .
 - t_{PLH} and t_{PHL} are the same as t_{pd} .
 - V_{CC1} is the V_{CC} associated with the input port.
 - V_{CCO} is the V_{CC} associated with the output port.

图 6-1. Load Circuit and Voltage Waveforms

6 Detailed Description

6.1 Overview

The SN74AVC8T245 is an 8-bit, dual-supply noninverting transceiver with bidirectional voltage level translation. V_{CCA} supports pins A and the control pins (DIR and \overline{OE}), and V_{CCB} supports pins B. The A port is able to accept I/O voltages ranging from 1.2 V to 3.6 V, while the B port can accept I/O voltages from 1.2 V to 3.6 V. A high on DIR allows data transmission from A to B and a low on DIR allows data transmission from B to A when \overline{OE} is set to low. When \overline{OE} is set to high, both A and B are in the high-impedance state.

6.2 Functional Block Diagram

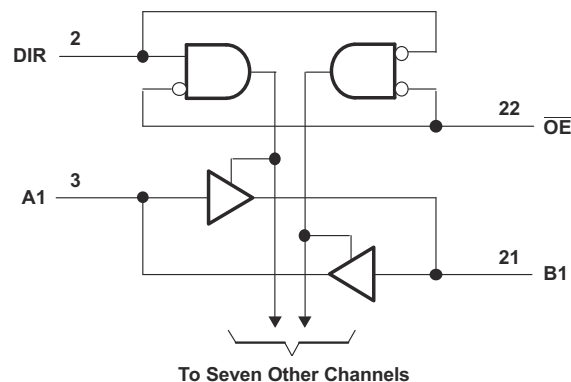

6.3 Feature Description

6.3.1 Fully Configurable Dual-Rail Design

The fully configurable dual-rail design allows each port to operate over the full 1.2-V to 3.6-V power-supply range. Both V_{CCA} and V_{CCB} can be supplied at any voltage between 1.2 V and 3.6 V making the device an excellent choice for translating between any of the low voltage nodes (1.2 V, 1.8 V, 2.5 V, and 3.3 V).

6.3.2 Support High-Speed Translation

SN74AVC8T245 can support high data rate application. The translated signal data rate can be up to 320Mbps when the device power supply is more than 1.8 V.

6.3.3 I_{off} Supports Partial-Power-Down Mode Operation

I_{off} prevents backflow current by disabling I/O output circuits when device is in partial power-down mode. The inputs and outputs for this device enter a high-impedance state when the device is powered down, inhibiting current backflow into the device. The maximum leakage into or out of any input or output pin on the device is specified by I_{off} in the *Electrical Characteristics*.

6.3.4 Balanced High-Drive CMOS Push-Pull Outputs

A balanced output allows the device to sink and source similar currents. The high drive capability of this device creates fast edges into light loads, so routing and load conditions should be considered to prevent ringing. Additionally, the outputs of this device are capable of driving larger currents than the device can sustain without being damaged. Two outputs can be connected together for 2X stronger output drive strength. The electrical and thermal limits defined in the *Absolute Maximum Ratings* must be followed at all times.

6.3.5 Vcc Isolation

The I/Os of both ports will enter a high-impedance state when one of the supplies are at GND, while the other supply is still connected to the device (IOZ shown in *Electrical Characteristics*).

6.4 Device Functional Modes

The SN74AVC8T245 is a voltage level transceiver that can operate from 1.2 V to 3.6 V (V_{CCA}) and 1.2 V to 3.6 V (V_{CCB}). The signal translation between 1.2 V and 3.6 V requires direction control and output enable control. When \overline{OE} is low and DIR is high, data transmission is from A to B. When \overline{OE} is low and DIR is low, data transmission is from B to A. When \overline{OE} is high, both output ports will be high-impedance.

**表 6-1. Function Table
(Each 8-Bit Section)**

INPUTS		OPERATION
\overline{OE}	DIR	
L	L	B data to A bus
L	H	A data to B bus
H	X	All outputs Hi-Z

7 Application and Implementation

注

以下のアプリケーション情報は、TI の製品仕様に含まれるものではなく、TI ではその正確性または完全性を保証いたしません。個々の目的に対する製品の適合性については、お客様の責任で判断していただくこととなります。お客様は自身の設計実装を検証しテストすることで、システムの機能を確認する必要があります。

7.1 Application Information

The SN74AVC8T245 device can be used in level-translation applications for interfacing devices or systems operating at different interface voltages with one another. The SN74AVC8T245 device is an excellent choice for data transmission when direction is different. It is recommended to tie all unused I/Os to GND. The device should not have any floating I/Os when changing translation direction. The maximum data rate can be up to 320Mbps when device voltage power supply is more than 1.8 V.

7.2 Typical Application



図 7-1. Typical Application Schematic

7.2.1 Design Requirements

For this design example, use the parameters listed in 表 7-1.

表 7-1. Design Parameters

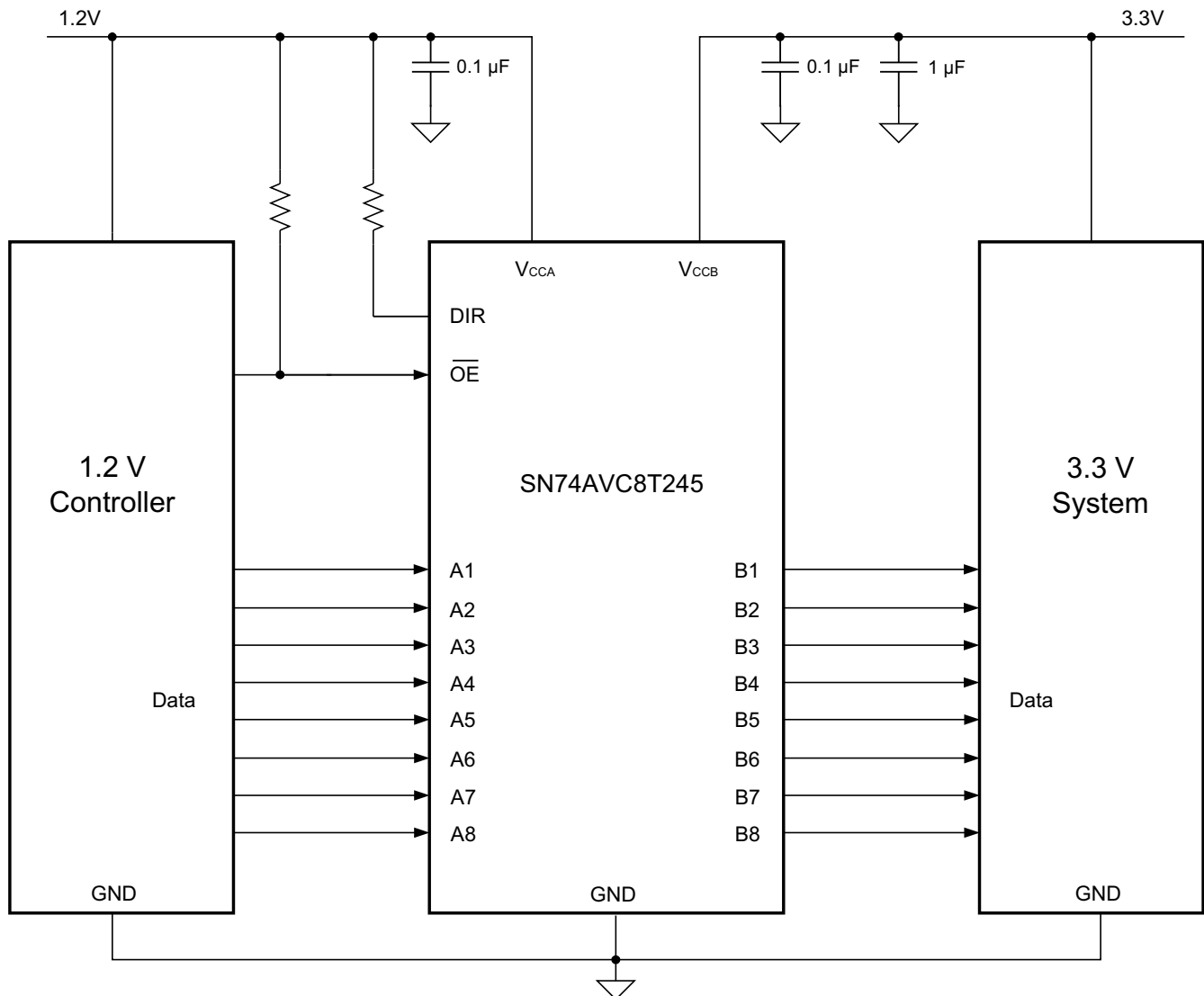
DESIGN PARAMETERS	EXAMPLE VALUE
Input voltage range	1.2 V to 3.6 V
Output voltage range	1.2 V to 3.6 V

7.2.2 Detailed Design Procedure

To begin the design process, determine the following:

- Input voltage range
 - Use the supply voltage of the device that is driving the SN74AVC8T245 device to determine the input voltage range. For a valid logic high the value must exceed the V_{IH} of the input port. For a valid logic low the value must be less than the V_{IL} of the input port.
- Output voltage range
 - Use the supply voltage of the device that the SN74AVC8T245 device is driving to determine the output voltage range.

7.2.3 Application Curve



図 7-2. Translation Up (1.2 V to 3.3 V) at 2.5 MHz

7.3 Power Supply Recommendations

The SN74AVC8T245 device uses two separate configurable power-supply rails, V_{CCA} and V_{CCB} . V_{CCA} accepts any supply voltage from 1.2 V to 3.6 V and V_{CCB} accepts any supply voltage from 1.2 V to 3.6 V. The A port and B port are designed to track V_{CCA} and V_{CCB} , respectively, allowing for low-voltage bidirectional translation between any of the 1.2-V, 1.5-V, 1.8-V, 2.5-V and 3.3-V voltage nodes. The recommendation is to first power-up the input supply rail to help avoid internal floating while the output supply rail ramps up. However, both power-supply rails can be ramped up simultaneously.

The output-enable \overline{OE} input circuit is designed so that it is supplied by V_{CCA} and when the \overline{OE} input is high, all outputs are placed in the high-impedance state. To ensure the high-impedance state of the outputs during power up or power down, the \overline{OE} input pin must be tied to V_{CCA} through a pullup resistor and must not be enabled until V_{CCA} and V_{CCB} are fully ramped and stable. The minimum value of the pullup resistor to V_{CCA} is determined by the current-sinking capability of the driver.

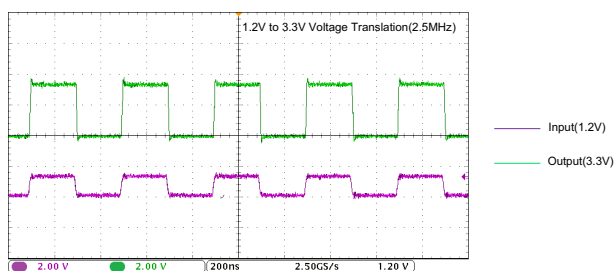
7.4 Layout

7.4.1 Layout Guidelines

For device reliability, follow common printed-circuit board layout guidelines such as:

- Use bypass capacitors on power supplies.
- Use short trace lengths to avoid excessive loading.
- Place pads on the signal paths for loading capacitors or pullup resistors to adjust the signals rise and fall times, depending on the system requirements.

7.4.2 Layout Example



图 7-3. SN74AVC8T245 Layout Example

8 Device and Documentation Support

8.1 Documentation Support

8.1.1 Related Documentation

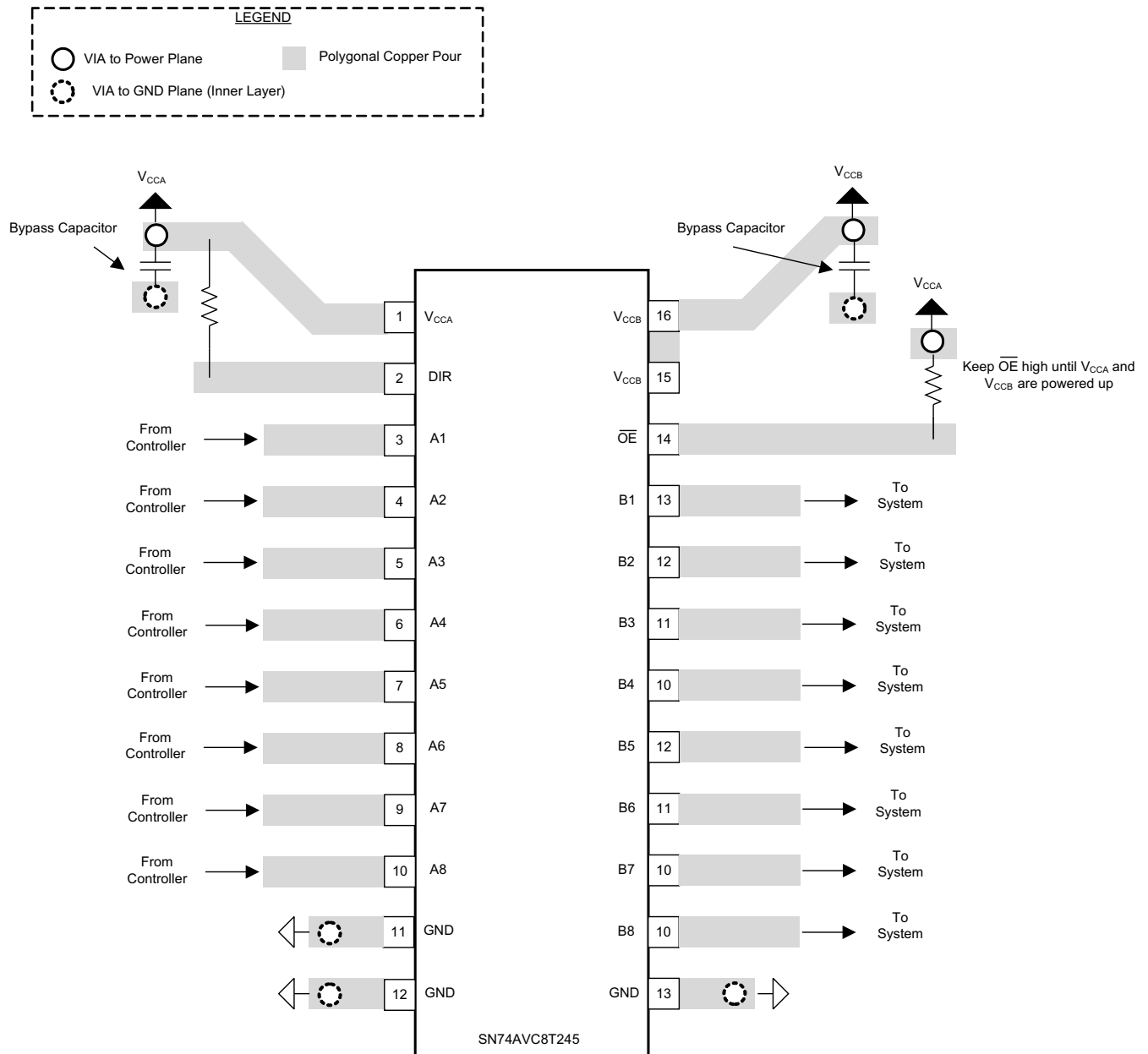
For related documentation, see the following:

- Texas Instruments, [Implications of Slow or Floating CMOS Inputs application note](#)

8.2 ドキュメントの更新通知を受け取る方法

ドキュメントの更新についての通知を受け取るには、www.tij.co.jp のデバイス製品フォルダを開いてください。[通知] をクリックして登録すると、変更されたすべての製品情報に関するダイジェストを毎週受け取ることができます。変更の詳細については、改訂されたドキュメントに含まれている改訂履歴をご覧ください。

8.3 サポート・リソース

テキサス・インスツルメンツ E2E™ サポート・フォーラムは、エンジニアが検証済みの回答と設計に関するヒントをエキスパートから迅速かつ直接得ることができる場所です。既存の回答を検索したり、独自の質問をしたりすることで、設計に必要な支援を迅速に得ることができます。

リンクされているコンテンツは、各寄稿者により「現状のまま」提供されるものです。これらはテキサス・インスツルメンツの仕様を構成するものではなく、必ずしもテキサス・インスツルメンツの見解を反映したものではありません。テキサス・インスツルメンツの[使用条件](#)を参照してください。

8.4 Trademarks

テキサス・インスツルメンツ E2E™ is a trademark of Texas Instruments.

すべての商標は、それぞれの所有者に帰属します。

8.5 静電気放電に関する注意事項



この IC は、ESD によって破損する可能性があります。テキサス・インスツルメンツは、IC を取り扱う際には常に適切な注意を払うことを推奨します。正しい取り扱いおよび設置手順に従わない場合、デバイスを破損するおそれがあります。

ESD による破損は、わずかな性能低下からデバイスの完全な故障まで多岐にわたります。精密な IC の場合、パラメータがわずかに変化するだけで公表されている仕様から外れる可能性があるため、破損が発生しやすくなっています。

8.6 用語集

[テキサス・インスツルメンツ用語集](#) この用語集には、用語や略語の一覧および定義が記載されています。

9 Revision History

資料番号末尾の英字は改訂を表しています。その改訂履歴は英語版に準じています。

Changes from Revision J (March 2017) to Revision K (November 2023)	Page
• 文書全体にわたって表、図、相互参照の採番方法を更新.....	1
• パッケージ・リード・サイズを含めるよう「パッケージ情報」表を更新	1
• Updated the <i>Thermal Information</i> table for all packages.....	6
Changes from Revision I (December 2014) to Revision J (March 2017)	Page
• Changed MAX value for Operating free-air temperature, T _A from: 85°C to: 125°C.....	5
• Added values for T _A = -40°C to +125°C in <i>Electrical Characteristics</i> and all <i>Switching Characteristics</i> tables.	6
• Added <i>Documentation Support</i> section, <i>Receiving Notification of Documentation Updates</i> , and <i>Community Resources</i> section.....	21

Changes from Revision H (February 2007) to Revision I (December 2014)
Page

- 「ピン構成および機能」セクション、「ESD 定格」表、「機能説明」セクション、「デバイスの機能モード」セクション、「アプリケーションと実装」セクション、「電源に関する推奨事項」セクション、「レイアウト」セクション、「デバイスおよびドキュメントのサポート」セクション、「メカニカル、パッケージ、および注文情報」セクションを追加 **1**
-

10 Mechanical, Packaging, and Orderable Information

The following pages include mechanical, packaging, and orderable information. This information is the most current data available for the designated devices. This data is subject to change without notice and revision of this document. For browser-based versions of this data sheet, refer to the left-hand navigation.

PACKAGING INFORMATION

Orderable Device	Status (1)	Package Type	Package Drawing	Pins	Package Qty	Eco Plan (2)	Lead finish/ Ball material (6)	MSL Peak Temp (3)	Op Temp (°C)	Device Marking (4/5)	Samples
74AVC8T245RHRLRG4	ACTIVE	VQFN	RHL	24	1000	RoHS & Green	NIPDAU	Level-2-260C-1 YEAR	-40 to 125	WE245	Samples
SN74AVC8T245DGVR	ACTIVE	TVSOP	DGV	24	2000	RoHS & Green	NIPDAU	Level-1-260C-UNLIM	-40 to 125	WE245	Samples
SN74AVC8T245PW	ACTIVE	TSSOP	PW	24	60	RoHS & Green	NIPDAU	Level-1-260C-UNLIM	-40 to 125	WE245	Samples
SN74AVC8T245PWE4	ACTIVE	TSSOP	PW	24	60	RoHS & Green	NIPDAU	Level-1-260C-UNLIM	-40 to 125	WE245	Samples
SN74AVC8T245PWG4	ACTIVE	TSSOP	PW	24	60	RoHS & Green	NIPDAU	Level-1-260C-UNLIM	-40 to 125	WE245	Samples
SN74AVC8T245PWR	ACTIVE	TSSOP	PW	24	2000	RoHS & Green	NIPDAU	Level-1-260C-UNLIM	-40 to 125	WE245	Samples
SN74AVC8T245PWRE4	ACTIVE	TSSOP	PW	24	2000	RoHS & Green	NIPDAU	Level-1-260C-UNLIM	-40 to 125	WE245	Samples
SN74AVC8T245PWRG4	ACTIVE	TSSOP	PW	24	2000	RoHS & Green	NIPDAU	Level-1-260C-UNLIM	-40 to 125	WE245	Samples
SN74AVC8T245RHRLR	ACTIVE	VQFN	RHL	24	1000	RoHS & Green	NIPDAU	Level-2-260C-1 YEAR	-40 to 125	WE245	Samples

(1) The marketing status values are defined as follows:

ACTIVE: Product device recommended for new designs.

LIFEBUY: TI has announced that the device will be discontinued, and a lifetime-buy period is in effect.

NRND: Not recommended for new designs. Device is in production to support existing customers, but TI does not recommend using this part in a new design.

PREVIEW: Device has been announced but is not in production. Samples may or may not be available.

OBSELETE: TI has discontinued the production of the device.

(2) **RoHS:** TI defines "RoHS" to mean semiconductor products that are compliant with the current EU RoHS requirements for all 10 RoHS substances, including the requirement that RoHS substance do not exceed 0.1% by weight in homogeneous materials. Where designed to be soldered at high temperatures, "RoHS" products are suitable for use in specified lead-free processes. TI may reference these types of products as "Pb-Free".

RoHS Exempt: TI defines "RoHS Exempt" to mean products that contain lead but are compliant with EU RoHS pursuant to a specific EU RoHS exemption.

Green: TI defines "Green" to mean the content of Chlorine (Cl) and Bromine (Br) based flame retardants meet JS709B low halogen requirements of <=1000ppm threshold. Antimony trioxide based flame retardants must also meet the <=1000ppm threshold requirement.

(3) MSL, Peak Temp. - The Moisture Sensitivity Level rating according to the JEDEC industry standard classifications, and peak solder temperature.

(4) There may be additional marking, which relates to the logo, the lot trace code information, or the environmental category on the device.

(5) Multiple Device Markings will be inside parentheses. Only one Device Marking contained in parentheses and separated by a "~" will appear on a device. If a line is indented then it is a continuation of the previous line and the two combined represent the entire Device Marking for that device.

(6) Lead finish/Ball material - Orderable Devices may have multiple material finish options. Finish options are separated by a vertical ruled line. Lead finish/Ball material values may wrap to two lines if the finish value exceeds the maximum column width.

Important Information and Disclaimer:The information provided on this page represents TI's knowledge and belief as of the date that it is provided. TI bases its knowledge and belief on information provided by third parties, and makes no representation or warranty as to the accuracy of such information. Efforts are underway to better integrate information from third parties. TI has taken and continues to take reasonable steps to provide representative and accurate information but may not have conducted destructive testing or chemical analysis on incoming materials and chemicals. TI and TI suppliers consider certain information to be proprietary, and thus CAS numbers and other limited information may not be available for release.

In no event shall TI's liability arising out of such information exceed the total purchase price of the TI part(s) at issue in this document sold by TI to Customer on an annual basis.

OTHER QUALIFIED VERSIONS OF SN74AVC8T245 :

- Automotive : [SN74AVC8T245-Q1](#)

NOTE: Qualified Version Definitions:

- Automotive - Q100 devices qualified for high-reliability automotive applications targeting zero defects

TAPE AND REEL INFORMATION

QUADRANT ASSIGNMENTS FOR PIN 1 ORIENTATION IN TAPE

*All dimensions are nominal

Device	Package Type	Package Drawing	Pins	SPQ	Reel Diameter (mm)	Reel Width W1 (mm)	A0 (mm)	B0 (mm)	K0 (mm)	P1 (mm)	W (mm)	Pin1 Quadrant
SN74AVC8T245DGVR	TVSOP	DGV	24	2000	330.0	12.4	6.9	5.6	1.6	8.0	12.0	Q1
SN74AVC8T245PWR	TSSOP	PW	24	2000	330.0	16.4	6.95	8.3	1.6	8.0	16.0	Q1
SN74AVC8T245RHLR	VQFN	RHL	24	1000	180.0	12.4	3.8	5.8	1.2	8.0	12.0	Q1

TAPE AND REEL BOX DIMENSIONS



*All dimensions are nominal

Device	Package Type	Package Drawing	Pins	SPQ	Length (mm)	Width (mm)	Height (mm)
SN74AVC8T245DGVR	TVSOP	DGV	24	2000	356.0	356.0	35.0
SN74AVC8T245PWR	TSSOP	PW	24	2000	356.0	356.0	35.0
SN74AVC8T245RHLR	VQFN	RHL	24	1000	210.0	185.0	35.0

TUBE

*All dimensions are nominal

Device	Package Name	Package Type	Pins	SPQ	L (mm)	W (mm)	T (μm)	B (mm)
SN74AVC8T245PW	PW	TSSOP	24	60	530	10.2	3600	3.5
SN74AVC8T245PWE4	PW	TSSOP	24	60	530	10.2	3600	3.5
SN74AVC8T245PWG4	PW	TSSOP	24	60	530	10.2	3600	3.5

PW0024A



PACKAGE OUTLINE
TSSOP - 1.2 mm max height

SMALL OUTLINE PACKAGE



NOTES:

1. All linear dimensions are in millimeters. Any dimensions in parenthesis are for reference only. Dimensioning and tolerancing per ASME Y14.5M.
2. This drawing is subject to change without notice.
3. This dimension does not include mold flash, protrusions, or gate burrs. Mold flash, protrusions, or gate burrs shall not exceed 0.15 mm per side.
4. This dimension does not include interlead flash. Interlead flash shall not exceed 0.25 mm per side.
5. Reference JEDEC registration MO-153.

EXAMPLE BOARD LAYOUT

PW0024A

TSSOP - 1.2 mm max height

SMALL OUTLINE PACKAGE



LAND PATTERN EXAMPLE
EXPOSED METAL SHOWN
SCALE: 10X



SOLDER MASK DETAILS

4220208/A 02/2017

NOTES: (continued)

6. Publication IPC-7351 may have alternate designs.
7. Solder mask tolerances between and around signal pads can vary based on board fabrication site.

EXAMPLE STENCIL DESIGN

PW0024A

TSSOP - 1.2 mm max height

SMALL OUTLINE PACKAGE



NOTES: (continued)

8. Laser cutting apertures with trapezoidal walls and rounded corners may offer better paste release. IPC-7525 may have alternate design recommendations.
9. Board assembly site may have different recommendations for stencil design.

DGV (R-PDSO-G**)

PLASTIC SMALL-OUTLINE

24 PINS SHOWN



4073251/E 08/00

- NOTES: A. All linear dimensions are in millimeters.
 B. This drawing is subject to change without notice.
 C. Body dimensions do not include mold flash or protrusion, not to exceed 0,15 per side.
 D. Falls within JEDEC: 24/48 Pins – MO-153
 14/16/20/56 Pins – MO-194

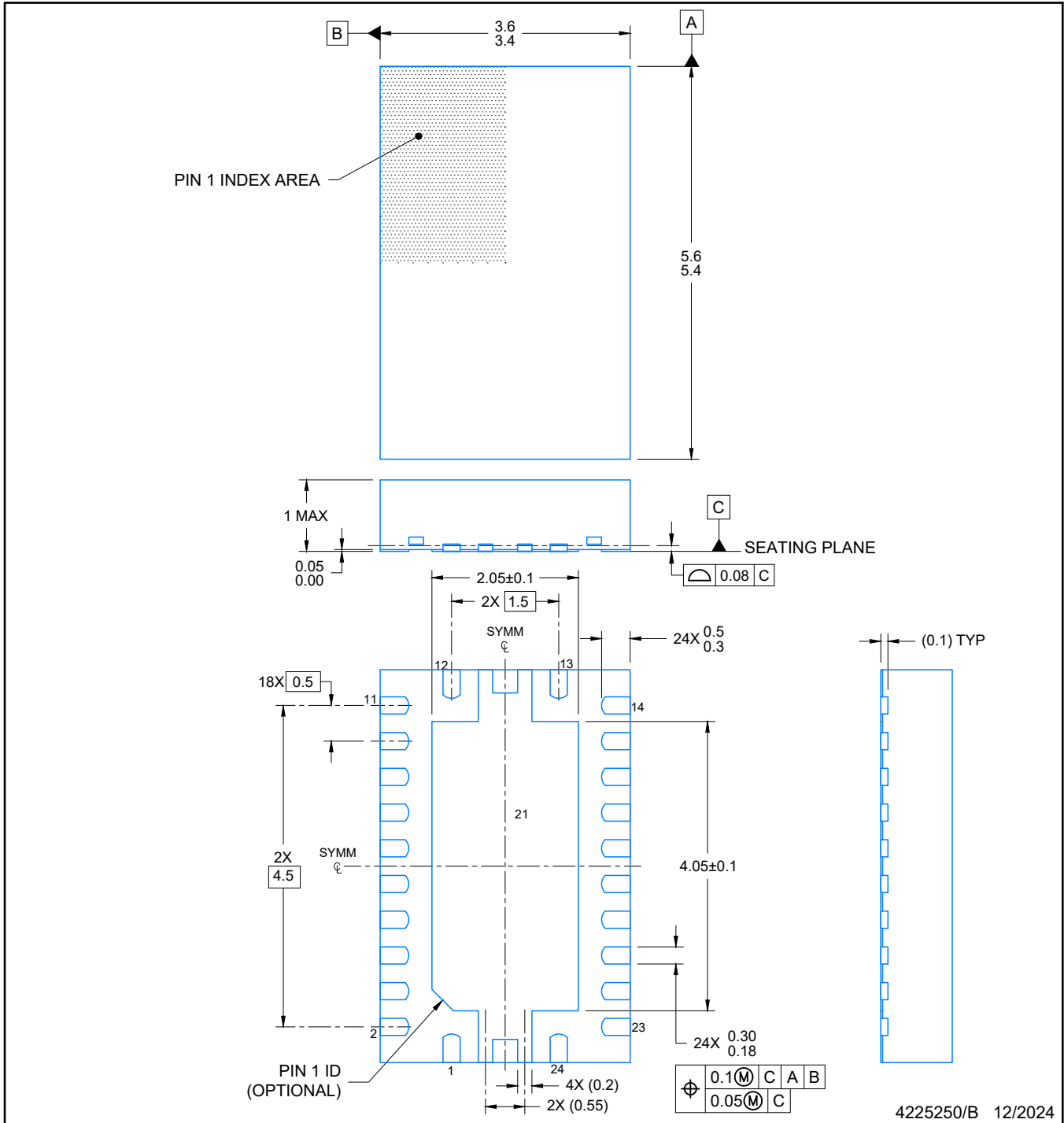

4225250/B 12/2024

NOTES:

1. All linear dimensions are in millimeters. Any dimensions in parenthesis are for reference only. Dimensioning and tolerancing per ASME Y14.5M.
2. This drawing is subject to change without notice.
3. The package thermal pad must be soldered to the printed circuit board for optimal thermal and mechanical performance.

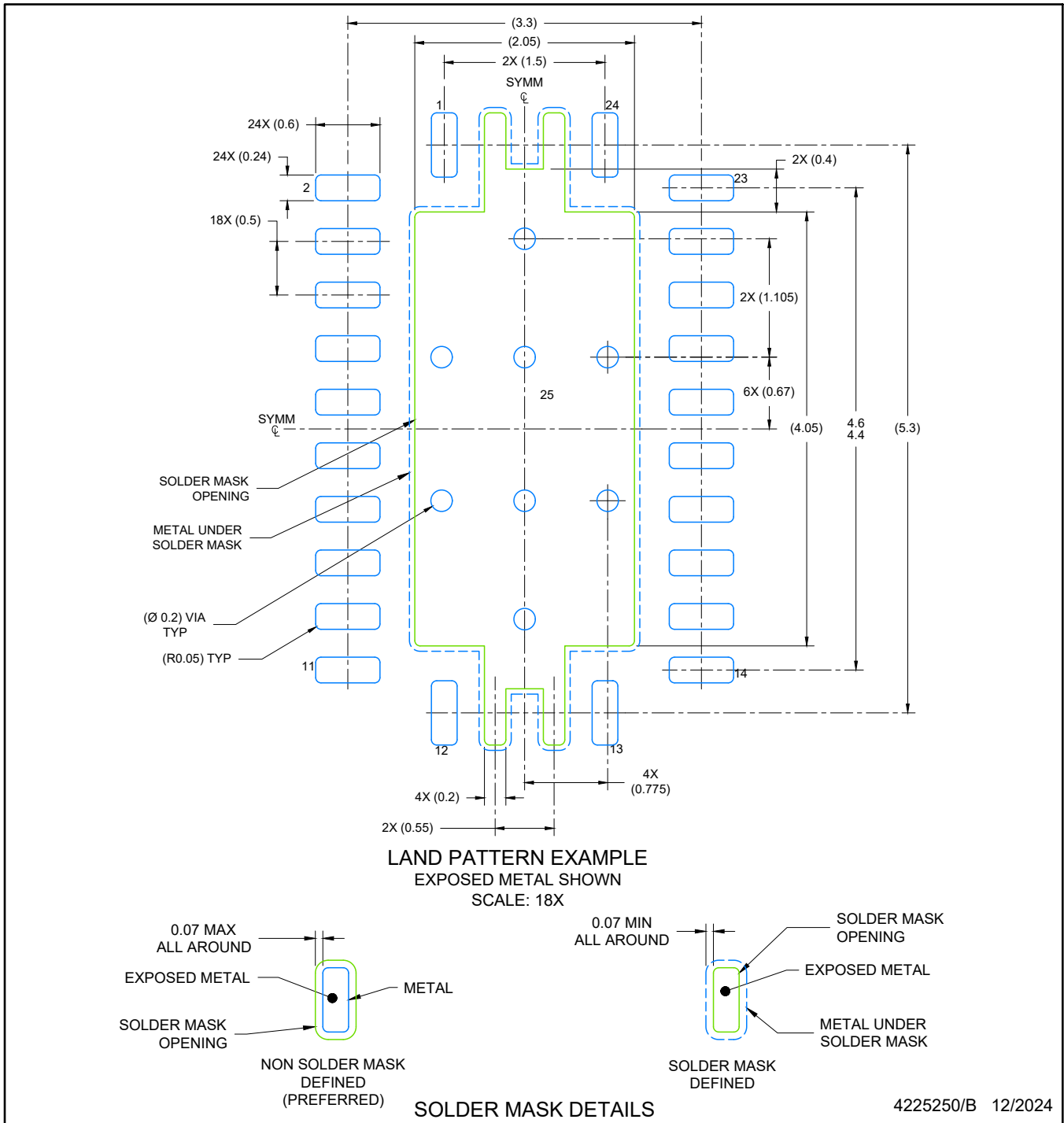

NOTES: (continued)

4. This package is designed to be soldered to a thermal pad on the board. For more information, see Texas Instruments literature number SLUA271 (www.ti.com/lit/sluea271).
5. Vias are optional depending on application, refer to device data sheet. If any vias are implemented, refer to their locations shown on this view. It is recommended that vias under paste be filled, plugged or tented.

EXAMPLE STENCIL DESIGN

VQFN - 1 mm max height

RHL0024A

PLASTIC QUAD FLATPACK- NO LEAD

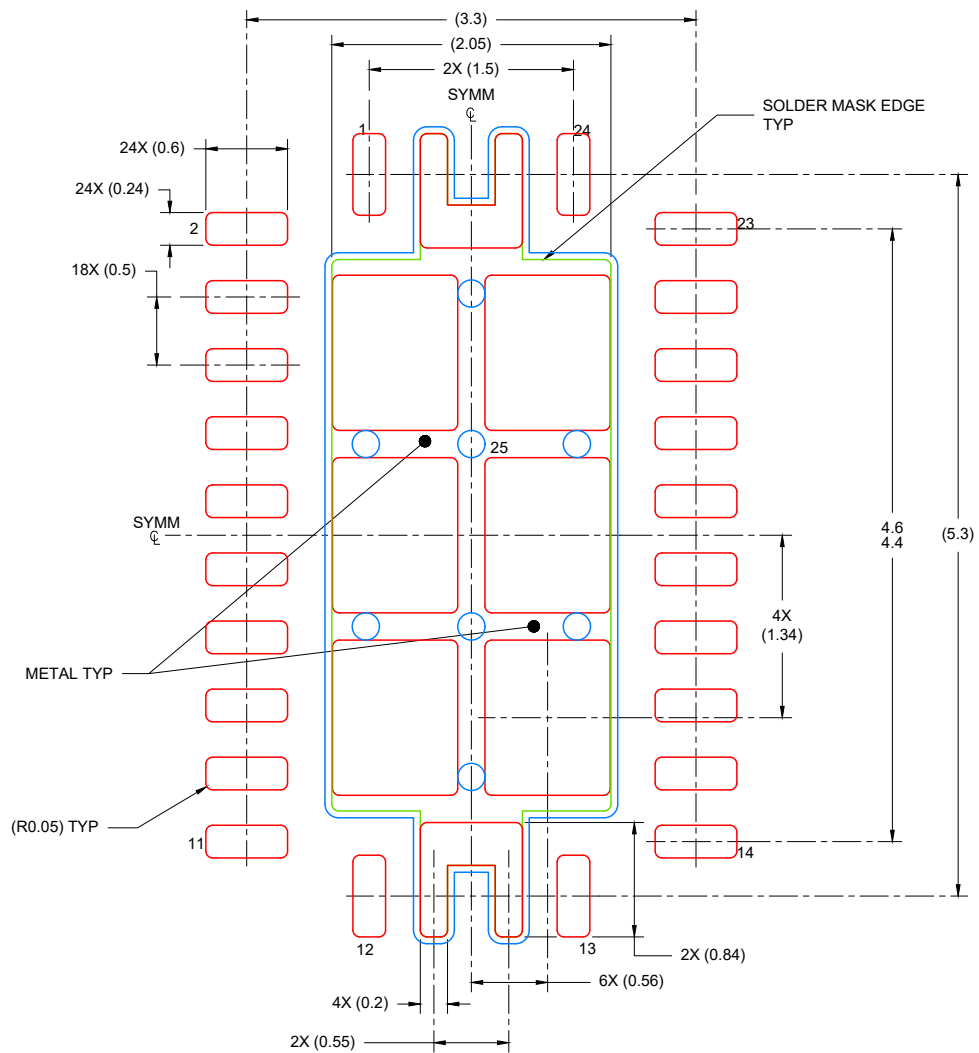

SOLDER PASTE EXAMPLE
BASED ON 0.125 mm THICK STENCIL

EXPOSED PAD
80% PRINTED COVERAGE BY AREA
SCALE: 18X

4225250/B 12/2024

NOTES: (continued)

6. Laser cutting apertures with trapezoidal walls and rounded corners may offer better paste release. IPC-7525 may have alternate design recommendations.

重要なお知らせと免責事項

テキサス・インスツルメンツは、技術データと信頼性データ(データシートを含みます)、設計リソース(リファレンス デザインを含みます)、アプリケーションや設計に関する各種アドバイス、Web ツール、安全性情報、その他のリソースを、欠陥が存在する可能性のある「現状のまま」提供しており、商品性および特定目的に対する適合性の黙示保証、第三者の知的財産権の非侵害保証を含むいかなる保証も、明示的または黙示的にかかわらず拒否します。

これらのリソースは、テキサス・インスツルメンツ製品を使用する設計の経験を積んだ開発者への提供を意図したものです。(1) お客様のアプリケーションに適したテキサス・インスツルメンツ製品の選定、(2) お客様のアプリケーションの設計、検証、試験、(3) お客様のアプリケーションに該当する各種規格や、その他のあらゆる安全性、セキュリティ、規制、または他の要件への確実な適合に関する責任を、お客様のみが単独で負うものとし、ます。

上記の各種リソースは、予告なく変更される可能性があります。これらのリソースは、リソースで説明されているテキサス・インスツルメンツ製品を使用するアプリケーションの開発の目的でのみ、テキサス・インスツルメンツはその使用をお客様に許諾します。これらのリソースに関して、他の目的で複製することや掲載することは禁止されています。テキサス・インスツルメンツや第三者の知的財産権のライセンスが付与されている訳ではありません。お客様は、これらのリソースを自身で使用した結果発生するあらゆる申し立て、損害、費用、損失、責任について、テキサス・インスツルメンツおよびその代理人を完全に補償するものとし、テキサス・インスツルメンツは一切の責任を拒否します。

テキサス・インスツルメンツの製品は、[テキサス・インスツルメンツの販売条件](#)、または [ti.com](https://www.ti.com) やかかるテキサス・インスツルメンツ製品の関連資料などのいずれかを通じて提供する適用可能な条項の下で提供されています。テキサス・インスツルメンツがこれらのリソースを提供することは、適用されるテキサス・インスツルメンツの保証または他の保証の放棄の拡大や変更を意味するものではありません。

お客様がいかなる追加条項または代替条項を提案した場合でも、テキサス・インスツルメンツはそれらに異議を唱え、拒否します。

郵送先住所：Texas Instruments, Post Office Box 655303, Dallas, Texas 75265
Copyright © 2025, Texas Instruments Incorporated