

SN74AVCH2T45 2-Bit, 2-Supply, Bus Transceiver with Configurable Level-Shifting and Translation and 3-State Outputs

1 Features

- Available in the Texas Instruments NanoFree™ Package
- V_{CC} Isolation
- 2-Rail Design
- I/Os are 4.6V Tolerant
- Partial Power-Down-Mode Operation
- Bus Hold on Data Inputs
- Maximum Data Rates
 - 500Mbps (1.8V to 3.3V)
 - 320Mbps (< 1.8V to 3.3V)
 - 320Mbps (Level-Shifting to 2.5V or 1.8V)
 - 280Mbps (Level-Shifting to 1.5V)
 - 240Mbps (Level-Shifting to 1.2V)
- Latch-Up Performance Exceeds 100mA Per JESD 78, Class II
- ESD Protection Exceeds JESD 22

2 Applications

- Smartphone
- Servers
- Desktop PCs and Notebooks
- Other Portable Devices

3 Description

This 2-bit non-inverting bus transceiver uses two separate configurable power-supply rails. The A ports are designed to track V_{CCA} and accepts any supply voltage from 1.2V to 3.6V. The B ports are designed to track V_{CCB} and accepts any supply voltage from 1.2V to 3.6V. This allows for universal low-voltage bidirectional translation and level-shifting between any of the 1.2V, 1.5V, 1.8V, 2.5V, and 3.3V voltage nodes.

The SN74AVCH2T45 is designed for asynchronous communication between two data buses. The logic levels of the direction-control (DIR pin) input activate either the B-port outputs or the A-port outputs. The device transmits data from the A bus to the B bus when the B-port outputs are activated and from the B bus to the A bus when the A-port outputs are activated. The SN74AVCH2T45 features active bus-hold circuitry, which holds unused or un-driven inputs at a valid logic state. TI does not recommend using pull-up or pull-down resistors with the bus-hold circuitry.

This device is fully specified for partial-power-down applications using I_{off} . The I_{off} circuitry disables the outputs, preventing damaging current backflow through the device when it is powered down. The V_{CC} isolation feature ensures that if either V_{CC} input is at GND, then both outputs are in the high-impedance state. The bus-hold circuitry on the powered-up side always stays active.

Active bus-hold circuitry holds unused or un-driven inputs at a valid logic state. NanoFree package technology is a major breakthrough in IC packaging concepts, using the die as the package.

Package Information

PART NUMBER	PACKAGE (1)	PACKAGE SIZE (2)
SN74AVCH2T45	DCT (SSOP, 8)	2.95mm × 4.00mm
	DCU (VSSOP, 8)	3.10mm × 2.00mm
	YZP, (DSBGA, 8)	1.89mm × 0.89mm

(1) For more information, see [Section 11](#)

(2) The package size (length × width) is a nominal value and includes pins where applicable

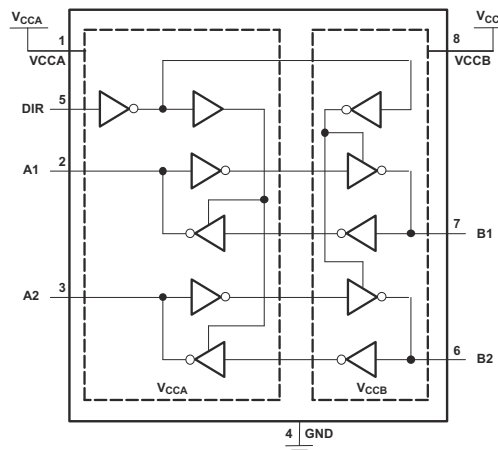

Logic Diagram (Positive Logic)



Table of Contents

1 Features	1	7.1 Overview.....	13
2 Applications	1	7.2 Functional Block Diagram.....	13
3 Description	1	7.3 Feature Description.....	14
4 Pin Configurations and Functions	3	7.4 Device Functional Modes.....	14
5 Specifications	4	8 Application and Implementation	15
5.1 Absolute Maximum Ratings.....	4	8.1 Application Information.....	15
5.2 ESD Ratings.....	4	8.2 Typical Applications.....	15
5.3 Recommended Operating Conditions.....	5	8.3 Power Supply Recommendations.....	18
5.4 Thermal Information.....	6	8.4 Layout.....	18
5.5 Electrical Characteristics.....	6	9 Device and Documentation Support	20
5.6 Switching Characteristics: $V_{CCA} = 1.2V$	7	9.1 Documentation Support.....	20
5.7 Switching Characteristics: $V_{CCA} = 1.5V$	8	9.2 Receiving Notification of Documentation Updates.....	20
5.8 Switching Characteristics: $V_{CCA} = 1.8V$	9	9.3 Support Resources.....	20
5.9 Switching Characteristics: $V_{CCA} = 2.5V$	9	9.4 Trademarks.....	20
5.10 Switching Characteristics: $V_{CCA} = 3.3V$	10	9.5 Electrostatic Discharge Caution.....	20
5.11 Operating Characteristics.....	10	9.6 Glossary.....	20
5.12 Typical Characteristics.....	11	10 Revision History	21
6 Parameter Measurement Information	12	11 Mechanical, Packaging, and Orderable Information	21
7 Detailed Description	13		

4 Pin Configurations and Functions

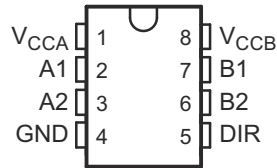

Figure 4-1. DCT and DCU Packages 8-Pin SSOP and VSSOP Top View

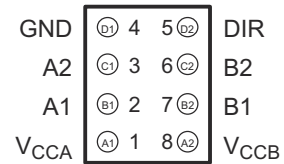

Figure 4-2. YZP Package 8-Pin DSBGA Bottom View

Table 4-1. Pin Functions

NAME	PIN		DESCRIPTION
	SSOP, VSSOP	DSBGA	
VCCA	1	A1	Supply Voltage A
VCCB	8	A2	Supply Voltage B
GND	4	D1	Ground
A1	2	B1	Output or input depending on state of DIR. Output level depends on V_{CCA} .
A2	3	C1	Output or input depending on state of DIR. Output level depends on V_{CCA} .
B1	7	B2	Output or input depending on state of DIR. Output level depends on V_{CCB} .
B2	6	C2	Output or input depending on state of DIR. Output level depends on V_{CCB} .
DIR	5	D2	Direction Pin, Connect to GND or to VCCA.

5 Specifications

5.1 Absolute Maximum Ratings

over operating free-air temperature range (unless otherwise noted)⁽¹⁾

		MIN	MAX	UNIT	
V_{CCA} V_{CCB}	Supply voltage	-0.5	4.6	V	
V_I	Input voltage ⁽²⁾	I/O ports (A port)	-0.5	4.6	V
		I/O ports (B port)	-0.5	4.6	
		Control inputs	-0.5	4.6	
V_O	Voltage range applied to any output in the high-impedance or power-off state ⁽²⁾	A port	-0.5	4.6	V
		B port	-0.5	4.6	
V_O	Voltage range applied to any output in the high or low state ^{(2) (3)}	A port	-0.5	$V_{CCA} + 0.5$	V
		B port	-0.5	$V_{CCB} + 0.5$	
I_{IK}	Input clamp current	$V_I < 0$	-50	mA	
I_{OK}	Output clamp current	$V_O < 0$	-50	mA	
I_O	Continuous output current		±50	mA	
	Continuous current through V_{CCA} , V_{CCB} , or GND		±100	mA	
T_J	Junction temperature	-40	150	°C	
T_{stg}	Storage temperature	-65	150	°C	

- (1) Stresses beyond those listed under *Absolute Maximum Ratings* may cause permanent damage to the device. These are stress ratings only, which do not imply functional operation of the device at these or any other conditions beyond those indicated under [Section 5.3](#). Exposure to absolute-maximum-rated conditions for extended periods may affect device reliability.
- (2) The input voltage and output negative-voltage ratings may be exceeded if the input and output current ratings are observed.
- (3) The output positive-voltage rating may be exceeded up to 4.6V maximum if the output current rating is observed.

5.2 ESD Ratings

		VALUE	UNIT
$V_{(ESD)}$	Electrostatic discharge	Human body model (HBM), per ANSI/ESDA/JEDEC JS-001 ⁽¹⁾	±8000
		Charged-device model (CDM), per JEDEC specification JESD22-C101 ⁽²⁾	±1000
		Machine Model (MM), Per JEDEC specification JESD22-A115-A	±200

- (1) JEDEC document JEP155 states that 500V HBM allows safe manufacturing with a standard ESD control process.
- (2) JEDEC document JEP157 states that 250V CDM allows safe manufacturing with a standard ESD control process.

5.3 Recommended Operating Conditions

over operating free-air temperature range (unless otherwise noted)⁽³⁾ ⁽⁴⁾ ⁽⁵⁾

		$V_{CCI}^{(1)}$	$V_{CCO}^{(2)}$	MIN	NOM	MAX	UNIT
V_{CCA}	Supply voltage			1.2		3.6	V
V_{CCB}	Supply voltage			1.2		3.6	V
V_{IH}	High-level input voltage	Data inputs ⁽⁴⁾	1.2V to 1.95V	$V_{CCI}^{(1)} \times 0.65$			V
			1.95V to 2.7V	1.6			
			2.7V to 3.6V	2			
V_{IL}	Low-level input voltage	Data inputs ⁽⁴⁾	1.2V to 1.95V	$V_{CCI}^{(1)} \times 0.35$			V
			1.95V to 2.7V	0.7			
			2.7V to 3.6V	0.8			
V_{IH}	High-level input voltage	DIR (referenced to V_{CCA}) ⁽⁵⁾	1.2V to 1.95V	$V_{CCA} \times 0.65$			V
			1.95 V to 2.7V	1.6			
			2.7V to 3.6V	2			
V_{IL}	Low-level input voltage	DIR (referenced to V_{CCA}) ⁽⁵⁾	1.2V to 1.95V	$V_{CCA} \times 0.35$			V
			1.95V to 2.7V	0.7			
			2.7V to 3.6V	0.8			
V_I	Input voltage			0		3.6	V
V_O	Output voltage	Active state		0		$V_{CCO}^{(2)}$	V
		3-state		0		3.6	V
I_{OH}	High-level output current		1.2V			-3	mA
			1.4V to 1.6V			-6	
			1.65V to 1.95V			-8	
			2.3V to 2.7V			-9	
			3V to 3.6V			-12	
I_{OL}	Low-level output current		1.2V			3	mA
			1.4V to 1.6V			6	
			1.65V to 1.95V			8	
			2.3V to 2.7V			9	
			3V to 3.6V			12	
$\Delta t/\Delta v$	Input transition rise or fall rate					5	ns/V
T_A	Operating free-air temperature			-40		85	°C

- (1) V_{CCI} is the voltage associated with the input port supply V_{CCA} or V_{CCB} .
- (2) V_{CCO} is the voltage associated with the output port supply V_{CCA} or V_{CCB} .
- (3) All unused data inputs of the device must be held at V_{CCI} or GND to ensure proper device operation. Refer to the TI application report, [Implications of Slow or Floating CMOS Inputs](#).
- (4) For V_{CCI} values not specified in the data sheet, V_{IH} min = $V_{CCI} \times 0.7V$, V_{IL} max = $V_{CCI} \times 0.3V$.
- (5) For V_{CCI} values not specified in the data sheet, V_{IH} min = $V_{CCA} \times 0.7V$, V_{IL} max = $V_{CCA} \times 0.3V$.

5.4 Thermal Information

THERMAL METRIC ⁽¹⁾		SN74AVCH2T45			UNIT
		DCT (SSOP)	DCU (VSSOP)	YZP (DSBGA)	
		8 PINS	8 PINS	8 PINS	
R _{θJA}	Junction-to-ambient thermal resistance	183.1	246.9	105.8	°C/W
R _{θJC(top)}	Junction-to-case (top) thermal resistance	101.5	95.2	1.6	
R _{θJB}	Junction-to-board thermal resistance	111.0	158.4	10.8	
ψ _{JT}	Junction-to-top characterization parameter	27.6	34.1	3.1	
ψ _{JB}	Junction-to-board characterization parameter	109.2	157.5	10.8	

(1) For more information about traditional and new thermal metrics, see the [IC Package Thermal Metrics](#) application report.

5.5 Electrical Characteristics

over recommended operating free-air temperature range (unless otherwise noted)^{(5) (6)}

PARAMETER	TEST CONDITIONS	V _{CCA}	V _{CCB}	T _A = 25°C			–40°C to 85°C			UNIT
				MIN	TYP	MAX	MIN	TYP	MAX	
V _{OH} ⁽⁷⁾	I _{OH} = –100μA I _{OH} = –3mA I _{OH} = –6mA I _{OH} = –8mA I _{OH} = –9mA I _{OH} = –12mA	V _I = V _{IH}	1.2V to 3.6V	1.2V to 3.6V				V _{CCO} – 0.2		V
			1.2V	1.2V	0.95					
			1.4V	1.4V		1.05				
			1.65V	1.65V		1.2				
			2.3V	2.3V		1.75				
			3V	3V		2.3				
V _{OL} ⁽⁷⁾	I _{OL} = 100μA I _{OL} = 3mA I _{OL} = 6mA I _{OL} = 8mA I _{OL} = 9mA I _{OL} = 12mA	V _I = V _{IL}	1.2V to 3.6V	1.2V to 3.6V				0.2		V
			1.2V	1.2V	0.15					
			1.4V	1.4V		0.35				
			1.65V	1.65V		0.45				
			2.3V	2.3V		0.55				
			3V	3V		0.7				
I _I ⁽⁷⁾	DIR input	V _I = V _{CCA} or GND	1.2V to 3.6V	1.2V to 3.6V	±0.025	±0.25			±1	μA
I _{BHL} ⁽¹⁾		V _I = 0.42V	1.2V	1.2V	25					μA
		V _I = 0.49V	1.4V	1.4V		15				
		V _I = 0.58V	1.65V	1.65V		25				
		V _I = 0.7V	2.3V	2.3V		45				
		V _I = 0.8V	3.3V	3.3V		100				
I _{BHH} ⁽²⁾		V _I = 0.78V	1.2V	1.2V	–25					μA
		V _I = 0.91V	1.4V	1.4V		–15				
		V _I = 1.07V	1.65V	1.65V		–25				
		V _I = 1.6V	2.3V	2.3V		–45				
		V _I = 2V	3.3V	3.3V		–100				
I _{BHLO} ⁽³⁾	V _I = 0 to V _{CC}	1.2V	1.2V	50					μA	
		1.6V	1.6V		125					
		1.95V	1.95V		200					
		2.7V	2.7V		300					
		3.6V	3.6V		500					
I _{BHHO} ⁽⁴⁾	V _I = 0 to V _{CC}	1.2V	1.2V	–50					μA	
		1.6V	1.6V		–125					
		1.95V	1.95V		–200					
		2.7V	2.7V		–300					
		3.6V	3.6V		–500					
I _{off} ⁽⁸⁾	A port	V _I or V _O = 0 to 3.6V	0V	0V to 3.6V	±0.1	±1			±5	μA
	B port		0V to 3.6V	0V	±0.1	±1			±5	

over recommended operating free-air temperature range (unless otherwise noted)^{(5) (6)}

PARAMETER	TEST CONDITIONS	V _{CCA}	V _{CCB}	T _A = 25°C			–40°C to 85°C			UNIT
				MIN	TYP	MAX	MIN	TYP	MAX	
I _{OZ} ⁽⁸⁾	B port	V _O = V _{CCO} or GND, V _I = V _{CCI} or GND	0V	3.6V	±0.5	±2.5			±5	μA
	A port		3.6V	0V	±0.5	±2.5			±5	
I _{CCA} ⁽⁸⁾		V _I = V _{CCI} or GND, I _O = 0	1.2V to 3.6V	1.2V to 3.6V					10	μA
			0V	3.6V					–2	
			3.6V	0V					10	
I _{CCB} ⁽⁸⁾		V _I = V _{CCI} or GND, I _O = 0	1.2V to 3.6V	1.2V to 3.6V					10	μA
			0V	3.6V					10	
			3.6V	0V					–2	
I _{CCA} + I _{CCB}		V _I = V _{CCI} or GND, I _O = 0	1.2V to 3.6V	1.2V to 3.6V					20	μA
C _i	Control inputs	V _I = 3.3V or GND	3.3V	3.3V	2.5					pF
C _{io}	A or B port	V _I = 3.3 V or GND	3.3V	3.3V	6					pF

- (1) The bus-hold circuit can sink at least the minimum low sustaining current at V_{IL} maximum. I_{BHL} should be measured after lowering V_{IN} to GND and then raising it to V_{IL} maximum.
- (2) The bus-hold circuit can source at least the minimum high sustaining current at V_{IH} minimum. I_{BHH} should be measured after raising V_{IN} to V_{CC} and then lowering it to V_{IH} minimum.
- (3) An external driver must source at least I_{BHLO} to switch this node from low to high.
- (4) An external driver must sink at least I_{BHHO} to switch this node from high to low.
- (5) V_{CCO} is the voltage associated with the output port supply V_{CCA} or V_{CCB}.
- (6) V_{CCI} is the voltage associated with the input port supply V_{CCA} or V_{CCB}.
- (7) V_{OH}: Output High Voltage; V_{OL}: Output Low Voltage; I_i: Control Input Current.
- (8) I_{off}: Partial Power Down Output current; I_{OZ}: Hi-Z Output Current; I_{CCA}: Supply A Current; I_{CCB}: Supply B Current.

5.6 Switching Characteristics: V_{CCA} = 1.2V

over recommended operating free-air temperature range, V_{CCA} = 1.2V (see Figure 6-1)

PARAMETER	FROM (INPUT)	TO (OUTPUT)	V _{CCB} = 1.2V	V _{CCB} = 1.5V	V _{CCB} = 1.8V	V _{CCB} = 2.5V	V _{CCB} = 3.3V	UNIT
			TYP	TYP	TYP	TYP	TYP	
t _{PLH} ⁽²⁾	A	B	3.1	2.6	2.4	2.2	2.2	ns
t _{PHL} ⁽²⁾			3.1	2.6	2.4	2.2	2.2	
t _{PLH} ⁽²⁾	B	A	3.4	3.1	3	2.9	2.9	ns
t _{PHL} ⁽²⁾			3.4	3.1	3	2.9	2.9	
t _{PHZ} ⁽²⁾	DIR	A	5.2	5.2	5.1	5	4.8	ns
t _{PLZ} ⁽²⁾			5.2	5.2	5.1	5	4.8	
t _{PHZ} ⁽²⁾	DIR	B	5	4	3.8	2.8	3.2	ns
t _{PLZ} ⁽²⁾			5	4	3.8	2.8	3.2	
t _{PZH} ^{(2) (1)}	DIR	A	8.4	7.1	6.8	5.7	6.1	ns
t _{PZL} ^{(2) (1)}			8.4	7.1	6.8	5.7	6.1	
t _{PZH} ^{(2) (1)}	DIR	B	8.3	7.8	7.5	7.2	7	ns
t _{PZL} ^{(2) (1)}			8.3	7.8	7.5	7.2	7	

- (1) The enable time is a calculated value derived using the formula shown in the Section 8.2.2.1 section.
- (2) t_{PLH}: Low-to-high Propagation Delay; t_{PHL}: High-to-Low Propagation Delay; t_{PHZ}: High-to-Hi-Z Propagation Delay; t_{PLZ}: Low-to-Hi-Z Propagation Delay; t_{PZH}: Hi-Z-to-High Propagation Delay; t_{PZL}: Hi-Z-to-Low Propagation Delay

5.7 Switching Characteristics: $V_{CCA} = 1.5V$

over recommended operating free-air temperature range, $V_{CCA} = 1.5V \pm 0.1V$ (see [Figure 6-1](#))

PARAMETER	FROM (INPUT)	TO (OUTPUT)	$V_{CCB} = 1.2V$	$V_{CCB} = 1.5V \pm 0.1V$		$V_{CCB} = 1.8V \pm 0.15V$		$V_{CCB} = 2.5V \pm 0.2V$		$V_{CCB} = 3.3V \pm 0.3V$		UNIT
			TYP	MIN	MAX	MIN	MAX	MIN	MAX	MIN	MAX	
$t_{PLH}^{(2)}$	A	B	2.8	0.7	5.4	0.5	4.6	0.4	3.7	0.3	3.5	ns
$t_{PHL}^{(2)}$			2.8	0.7	5.4	0.5	4.6	0.4	3.7	0.3	3.5	
$t_{PLH}^{(2)}$	B	A	2.7	0.8	5.4	0.7	5.2	0.6	4.9	0.5	4.7	ns
$t_{PHL}^{(2)}$			2.7	0.8	5.4	0.7	5.2	0.6	4.9	0.5	4.7	
$t_{PHZ}^{(2)}$	DIR	A	3.9	1.3	8.5	1.3	7.8	1.1	7.7	1.4	7.6	ns
$t_{PLZ}^{(2)}$			3.9	1.3	8.5	1.3	7.8	1.1	7.7	1.4	7.6	
$t_{PHZ}^{(2)}$	DIR	B	4.7	1.1	7	1.4	6.9	1.2	6.9	1.7	7.1	ns
$t_{PLZ}^{(2)}$			4.7	1.1	7	1.4	6.9	1.2	6.9	1.7	7.1	
$t_{PZH}^{(2)(1)}$	DIR	A	7.4		12.4		12.1		11.8		11.8	ns
$t_{PZL}^{(2)(1)}$			7.4		12.4		12.1		11.8		11.8	
$t_{PZH}^{(2)(1)}$	DIR	B	6.7		13.9		12.4		11.4		11.1	ns
$t_{PZL}^{(2)(1)}$			6.7		13.9		12.4		11.4		11.1	

(1) The enable time is a calculated value derived using the formula shown in the [Section 8.2.2.1](#) section.

(2) t_{PLH} : Low-to-high Propagation Delay; t_{PHL} : High-to-Low Propagation Delay; t_{PHZ} : High-to-Hi-Z Propagation Delay; t_{PLZ} : Low-to-Hi-Z Propagation Delay; t_{PZH} : Hi-Z-to-High Propagation Delay; t_{PZL} : Hi-Z-to-Low Propagation Delay

5.8 Switching Characteristics: $V_{CCA} = 1.8V$

over recommended operating free-air temperature range, $V_{CCA} = 1.8V \pm 0.15V$ (see [Figure 6-1](#))

PARAMETER	FROM (INPUT)	TO (OUTPUT)	$V_{CCB} = 1.2V$	$V_{CCB} = 1.5V \pm 0.1V$		$V_{CCB} = 1.8V \pm 0.15V$		$V_{CCB} = 2.5V \pm 0.2V$		$V_{CCB} = 3.3V \pm 0.3V$		UNIT
			TYP	MIN	MAX	MIN	MAX	MIN	MAX	MIN	MAX	
$t_{PLH}^{(2)}$	A	B	2.7	0.5	5.2	0.4	4.3	0.2	3.4	0.2	3.1	ns
$t_{PHL}^{(2)}$			2.7	0.5	5.2	0.4	4.3	0.2	3.4	0.2	3.1	
$t_{PLH}^{(2)}$	B	A	2.4	0.7	4.7	0.5	4.4	0.5	4	0.4	3.8	ns
$t_{PHL}^{(2)}$			2.4	0.7	4.7	0.5	4.4	0.5	4	0.4	3.8	
$t_{PHZ}^{(2)}$	DIR	A	3.7	1.3	8.1	0.7	6.9	1.4	5.3	1.1	5.2	ns
$t_{PLZ}^{(2)}$			3.7	1.3	8.1	0.7	6.9	1.4	5.3	1.1	5.2	
$t_{PHZ}^{(2)}$	DIR	B	4.4	1.3	5.8	1.3	5.9	0.8	5.7	1.5	5.9	ns
$t_{PLZ}^{(2)}$			4.4	1.3	5.8	1.3	5.9	0.8	5.7	1.5	5.9	
$t_{PZH}^{(2)(1)}$	DIR	A	6.8		10.5		10.3		9.7		9.7	ns
$t_{PZL}^{(2)(1)}$			6.8		10.5		10.3		9.7		9.7	
$t_{PZH}^{(2)(1)}$	DIR	B	6.4		13.3		11.2		8.7		8.3	ns
$t_{PZL}^{(2)(1)}$			6.4		13.3		11.2		8.7		8.3	

(1) The enable time is a calculated value derived using the formula shown in the [Section 8.2.2.1](#) section.

(2) t_{PLH} : Low-to-high Propagation Delay; t_{PHL} : High-to-Low Propagation Delay; t_{PHZ} : High-to-Hi-Z Propagation Delay; t_{PLZ} : Low-to-Hi-Z Propagation Delay; t_{PZH} : Hi-Z-to-High Propagation Delay; t_{PZL} : Hi-Z-to-Low Propagation Delay

5.9 Switching Characteristics: $V_{CCA} = 2.5V$

over recommended operating free-air temperature range, $V_{CCA} = 2.5V \pm 0.2V$ (see [Figure 6-1](#))

PARAMETER	FROM (INPUT)	TO (OUTPUT)	$V_{CCB} = 1.2V$	$V_{CCB} = 1.5V \pm 0.1V$		$V_{CCB} = 1.8V \pm 0.15V$		$V_{CCB} = 2.5V \pm 0.2V$		$V_{CCB} = 3.3V \pm 0.3V$		UNIT
			TYP	MIN	MAX	MIN	MAX	MIN	MAX	MIN	MAX	
$t_{PLH}^{(2)}$	A	B	2.6	0.4	4.9	0.2	4	0.2	3	0.2	2.6	ns
$t_{PHL}^{(2)}$			2.6	0.4	4.9	0.2	4	0.2	3	0.2	2.6	
$t_{PLH}^{(2)}$	B	A	2.1	0.6	3.8	0.5	3.4	0.4	3	0.3	2.8	ns
$t_{PHL}^{(2)}$			2.1	0.6	3.8	0.5	3.4	0.4	3	0.3	2.8	
$t_{PHZ}^{(2)}$	DIR	A	2.4	0.7	7.9	0.8	6.4	0.8	5	0.5	4.3	ns
$t_{PLZ}^{(2)}$			2.4	0.7	7.9	0.8	6.4	0.8	5	0.5	4.3	
$t_{PHZ}^{(2)}$	DIR	B	3.8	1	4.3	0.6	4.3	0.5	4.2	1.1	4.1	ns
$t_{PLZ}^{(2)}$			3.8	1	4.3	0.6	4.3	0.5	4.2	1.1	4.1	
$t_{PZH}^{(2)(1)}$	DIR	A	5.9		8.5		7.7		7.2		6.9	ns
$t_{PZL}^{(2)(1)}$			5.9		8.5		7.7		7.2		6.9	
$t_{PZH}^{(2)(1)}$	DIR	B	5		12.8		10.4		8		6.9	ns
$t_{PZL}^{(2)(1)}$			5		12.8		10.4		8		6.9	

(1) The enable time is a calculated value derived using the formula shown in the [Section 8.2.2.1](#) section.

(2) t_{PLH} : Low-to-high Propagation Delay; t_{PHL} : High-to-Low Propagation Delay; t_{PHZ} : High-to-Hi-Z Propagation Delay; t_{PLZ} : Low-to-Hi-Z Propagation Delay; t_{PZH} : Hi-Z-to-High Propagation Delay; t_{PZL} : Hi-Z-to-Low Propagation Delay

5.10 Switching Characteristics: $V_{CCA} = 3.3V$

over recommended operating free-air temperature range, $V_{CCA} = 3.3V \pm 0.3V$ (see Figure 6-1)

PARAMETER	FROM (INPUT)	TO (OUTPUT)	$V_{CCB} = 1.2V$	$V_{CCB} = 1.5V \pm 0.1V$		$V_{CCB} = 1.8V \pm 0.15V$		$V_{CCB} = 2.5V \pm 0.2V$		$V_{CCB} = 3.3V \pm 0.3V$		UNIT
			TYP	MIN	MAX	MIN	MAX	MIN	MAX	MIN	MAX	
$t_{PLH}^{(2)}$	A	B	2.5	0.3	4.7	0.2	3.8	0.2	2.8	0.2	2.4	ns
$t_{PHL}^{(2)}$			2.5	0.3	4.7	0.2	3.8	0.2	2.8	0.2	2.4	
$t_{PLH}^{(2)}$	B	A	2.1	0.6	3.6	0.4	3.1	0.3	2.6	0.3	2.4	ns
$t_{PHL}^{(2)}$			2.1	0.6	3.6	0.4	3.1	0.3	2.6	0.3	2.4	
$t_{PHZ}^{(2)}$	DIR	A	2.9	1.1	8	1	6.5	1.3	4.7	1.2	4	ns
$t_{PLZ}^{(2)}$			2.9	1.1	8	1	6.5	1.3	4.7	1.2	4	
$t_{PHZ}^{(2)}$	DIR	B	3.4	0.5	6.6	0.3	5.6	0.3	4.6	1.1	4.2	ns
$t_{PLZ}^{(2)}$			3.4	0.5	6.6	0.3	5.6	0.3	4.6	1.1	4.2	
$t_{PZH}^{(2)(1)}$	DIR	A	5.5		10.2		8.7		7.2		6.6	ns
$t_{PZL}^{(2)(1)}$			5.5		10.2		8.7		7.2		6.6	
$t_{PZH}^{(2)(1)}$	DIR	B	5.4		12.7		10.3		7.5		6.4	ns
$t_{PZL}^{(2)(1)}$			5.4		12.7		10.3		7.5		6.4	

(1) The enable time is a calculated value derived using the formula shown in the Section 8.2.2.1 section.

(2) t_{PLH} : Low-to-high Propagation Delay; t_{PHL} : High-to-Low Propagation Delay; t_{PHZ} : High-to-Hi-Z Propagation Delay; t_{PLZ} : Low-to-Hi-Z Propagation Delay; t_{PZH} : Hi-Z-to-High Propagation Delay; t_{PZL} : Hi-Z-to-Low Propagation Delay

5.11 Operating Characteristics

$T_A = 25^\circ C$

PARAMETER		TEST CONDITIONS	$V_{CCA} = V_{CCB} = 1.2V$	$V_{CCA} = V_{CCB} = 1.5V$	$V_{CCA} = V_{CCB} = 1.8V$	$V_{CCA} = V_{CCB} = 2.5V$	$V_{CCA} = V_{CCB} = 3.3V$	UNIT
			TYP	TYP	TYP	TYP	TYP	
$C_{pdA}^{(1)}$	A-port input, B-port output	$C_L = 0,$ $f = 10MHz,$ $t_r^{(2)} = t_f^{(2)} = 1ns$	3	3	3	3	4	pF
	B-port input, A-port output		13	13	14	15	15	
$C_{pdB}^{(1)}$	A-port input, B-port output	$C_L = 0,$ $f = 10MHz,$ $t_r^{(2)} = t_f^{(2)} = 1ns$	13	13	14	15	15	pF
	B-port input, A-port output		3	3	3	3	4	

(1) Power dissipation capacitance per transceiver

(2) t_r : Rise time; t_f : Fall time

5.12 Typical Characteristics

5.12.1 Typical Propagation Delay (A to B) vs Load Capacitance, $T_A = 25^\circ\text{C}$, $V_{CCA} = 1.8\text{V}$

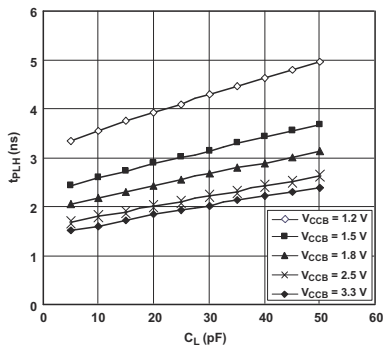

Figure 5-1. Typical A-to-B Propagation Delay, Low to High

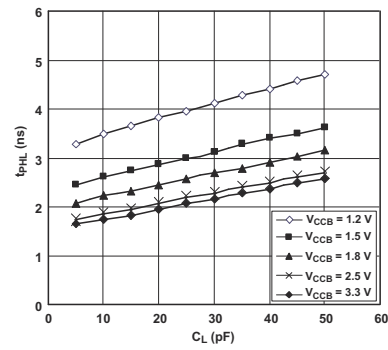

Figure 5-2. Typical A-to-B Propagation Delay, High to Low

5.12.2 Typical Propagation Delay (A to B) vs Load Capacitance, $T_A = 25^\circ\text{C}$, $V_{CCA} = 2.5\text{V}$

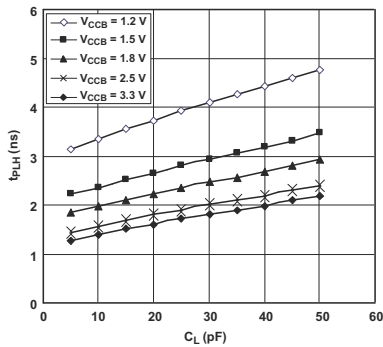

Figure 5-3. Typical A-to-B Propagation Delay, Low to High

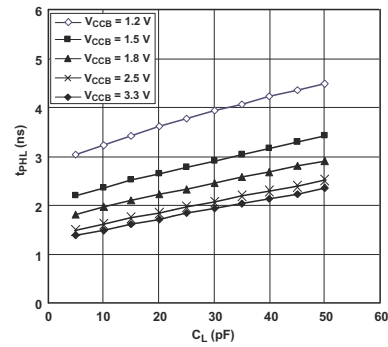

Figure 5-4. Typical A-to-B Propagation Delay, High to Low

5.12.3 Typical Propagation Delay (A to B) vs Load Capacitance, $T_A = 25^\circ\text{C}$, $V_{CCA} = 3.3\text{V}$

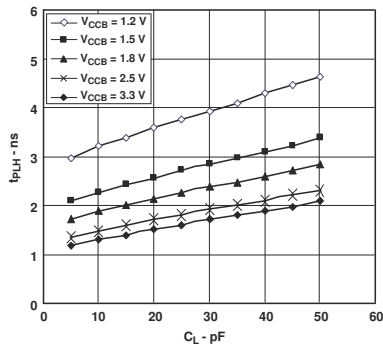

Figure 5-5. Typical A-to-B Propagation Delay, Low to High

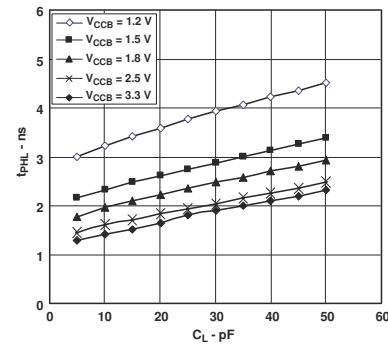
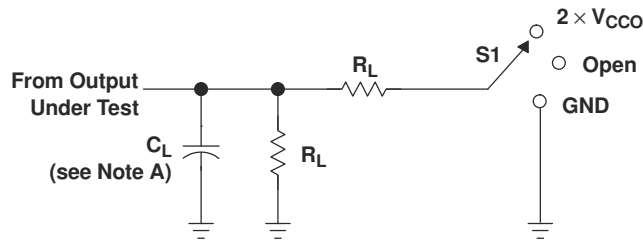

Figure 5-6. Typical A-to-B Propagation Delay, High to Low

6 Parameter Measurement Information

6.1



LOAD CIRCUIT

TEST	S1
t_{pd}	Open
t_{PLZ}/t_{PZL}	$2 \times V_{CCO}$
t_{PHZ}/t_{PZH}	GND

V_{CCO}	C_L	R_L	V_{TP}
1.2 V	15 pF	2 k Ω	0.1 V
1.5 V \pm 0.1 V	15 pF	2 k Ω	0.1 V
1.8 V \pm 0.15 V	15 pF	2 k Ω	0.15 V
2.5 V \pm 0.2 V	15 pF	2 k Ω	0.15 V
3.3 V \pm 0.3 V	15 pF	2 k Ω	0.3 V

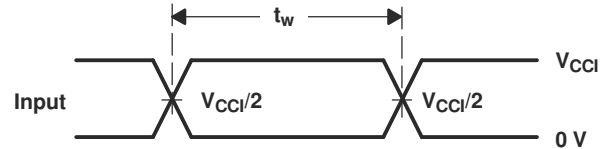

VOLTAGE WAVEFORMS
PULSE DURATION

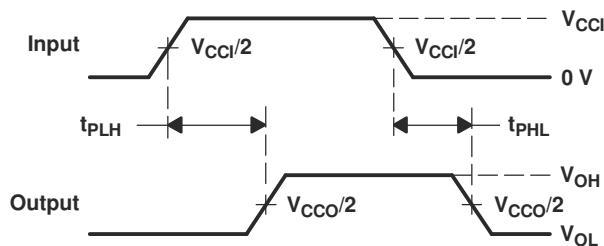

VOLTAGE WAVEFORMS
PROPAGATION DELAY TIMES

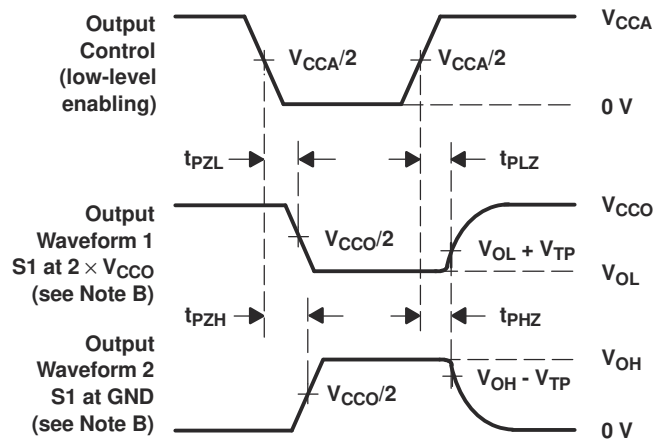

VOLTAGE WAVEFORMS
ENABLE AND DISABLE TIMES

- NOTES:
- A. C_L includes probe and jig capacitance.
 - B. Waveform 1 is for an output with internal conditions such that the output is low, except when disabled by the output control. Waveform 2 is for an output with internal conditions such that the output is high, except when disabled by the output control.
 - C. All input pulses are supplied by generators having the following characteristics: $PRR \leq 10$ MHz, $Z_O = 50 \Omega$, $dv/dt \geq 1$ V/ns.
 - D. The outputs are measured one at a time, with one transition per measurement.
 - E. t_{PLZ} and t_{PHZ} are the same as t_{dis} .
 - F. t_{PZL} and t_{PZH} are the same as t_{en} .
 - G. t_{PLH} and t_{PHL} are the same as t_{pd} .
 - H. V_{CCl} is the V_{CC} associated with the input port.
 - I. V_{CCO} is the V_{CC} associated with the output port.

Figure 6-1. Load Circuit and Voltage Waveforms

7 Detailed Description

7.1 Overview

This dual-bit non-inverting bus transceiver uses two separate configurable power-supply rails. The A port is designed to track V_{CCA} and accepts any supply voltage from 1.2 V to 3.6 V. The B port is designed to track V_{CCB} and accepts any supply voltage from 1.2 V to 3.6 V. This allows for universal low-voltage bidirectional translation and level-shifting between any of the 1.2 V, 1.5 V, 1.8 V, 2.5 V, and 3.3 V voltage nodes.

The SN74AVCH2T45 is designed for asynchronous communication between two data buses. The logic levels of the direction-control (DIR pin) input activate either the B-port outputs or the A-port outputs. The device transmits data from the A bus to the B bus when the B-port outputs are activated and from the B bus to the A bus when the A-port outputs are activated.

The SN74AVCH2T45 features active bus-hold circuitry.

The DIR input is powered by supply voltage from V_{CCA} .

This device is fully specified for partial-power-down applications using off output current (I_{off}). The I_{off} circuitry disables the outputs, preventing damaging current backflow through the device when it is powered down.

The V_{CC} isolation feature ensures that if either VCC input is at GND, both ports are put in a high-impedance state. This will prevent a false high or low logic being presented at the output.

NanoFree package technology is a major breakthrough in IC packaging concepts, using the die as the package.

7.2 Functional Block Diagram

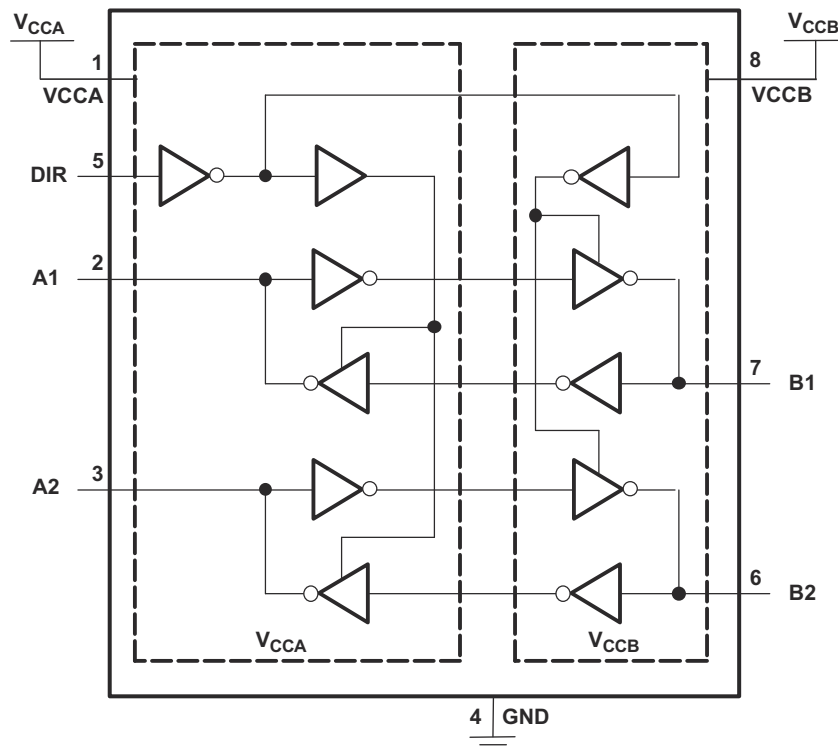

7.3 Feature Description

7.3.1 VCC Isolation

The V_{CC} isolation feature ensures that if either V_{CCA} or V_{CCB} are at GND, both ports will be in a high-impedance state (I_{OZ} shown in the [Section 7.2](#)). This prevents false logic levels from being presented to either bus.

7.3.2 2-Rail Design

Fully configurable 2-rail design allows each port to operate over the full 1.2 V to 3.6 V power-supply range.

7.3.3 IO Ports are 4.6 V Tolerant

The IO ports are up to 4.6 V tolerant

7.3.4 Partial Power Down Mode

This device is fully specified for partial-power-down applications using off output current (I_{off}). The I_{off} circuitry disables the outputs, preventing damaging current backflow through the device when it is powered down.

7.3.5 Bus Hold on Data Inputs

Active bus-hold circuitry holds unused or un-driven inputs at a valid logic state. TI does not recommend using pull-up or pull-down resistors with the bus-hold circuitry.

7.4 Device Functional Modes

Table 7-1. Function Table (Each Transceiver)

INPUT DIR	OPERATION
L	B data to A bus
H	A data to B bus

8 Application and Implementation

Note

Information in the following applications sections is not part of the TI component specification, and TI does not warrant its accuracy or completeness. TI's customers are responsible for determining suitability of components for their purposes, as well as validating and testing their design implementation to confirm system functionality.

8.1 Application Information

The SN74AVCH2T45 is used to shift IO voltage levels from one voltage domain to another. Each bus (bus A and bus B) have independent power supplies, and a direction pin is used to control the direction of data flow.

8.2 Typical Applications

8.2.1 Unidirectional Logic Level-Shifting Application

Figure 8-1 is an example of the SN74AVCH2T45 circuit used in a unidirectional logic level-shifting application.

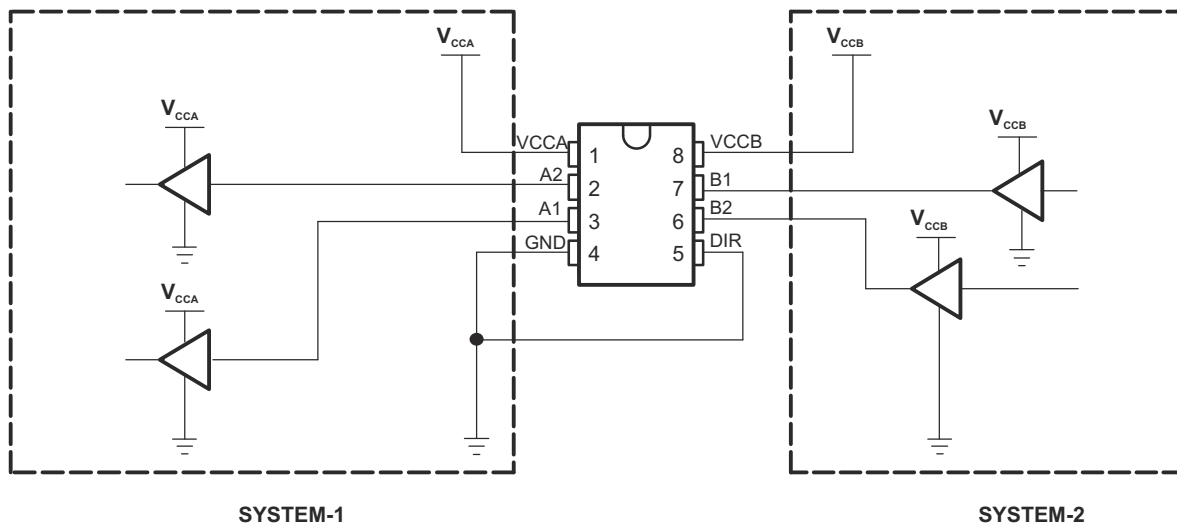

Figure 8-1. Unidirectional Logic Level-Shifting Application

8.2.1.1 Design Requirements

This device uses drivers which are enabled depending on the state of the DIR pin. The designer must know the intended flow of data and take care not to violate any of the high or low logic levels. Active bus-hold circuitry holds unused or un-driven inputs at a valid logic state. TI does not recommend using pull-up or pull-down resistors with the bus-hold circuitry.

8.2.1.2 Detailed Design Procedure

Table 8-1 lists the pins and pin descriptions of the SN74AVCH2T45 connections with SYSTEM-1 and SYSTEM-2.

Table 8-1. SN74AVCH2T45 Pin Connections With SYSTEM-1 and SYSTEM-2

PIN	NAME	DESCRIPTION
1	VCCA	SYSTEM-1 supply voltage (1.2V to 3.6V)
2	A1	Output level depends on V_{CCA} .
3	A2	Output level depends on V_{CCA} .
4	GND	Device GND
5	DIR	The GND (low-level) determines B-port to A-port direction.
6	B2	Input threshold value depends on V_{CCB} .
7	B1	Input threshold value depends on V_{CCB} .
8	VCCB	SYSTEM-2 supply voltage (1.2V to 3.6V)

8.2.1.3 Application Curve

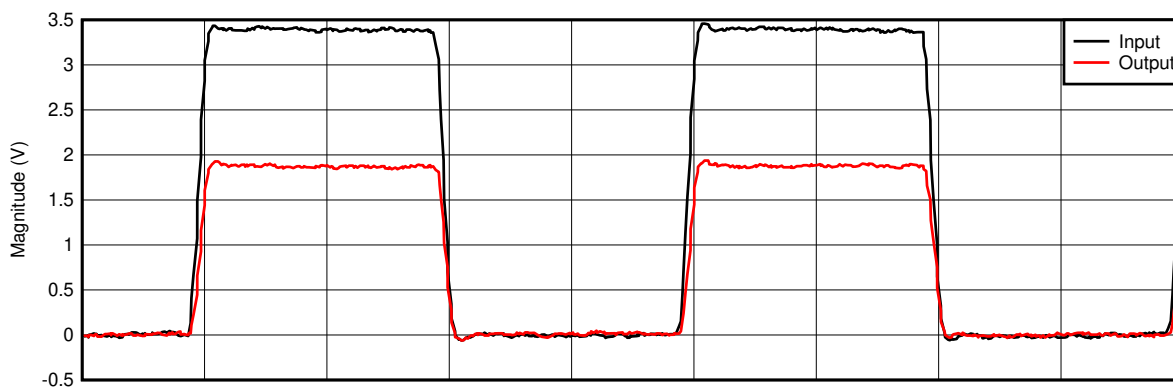

D002

Figure 8-2. 3.3- to 1.8-V Level-Shifting With 1MHz Square Wave

8.2.2 Bidirectional Logic Level-Shifting Application

Figure 8-3 shows the SN74AVCH2T45 used in a bidirectional logic level-shifting application. Because the SN74AVCH2T45 does not have an output-enable (OE) pin, system designers should take precautions to avoid bus contention between SYSTEM-1 and SYSTEM-2 when changing directions.

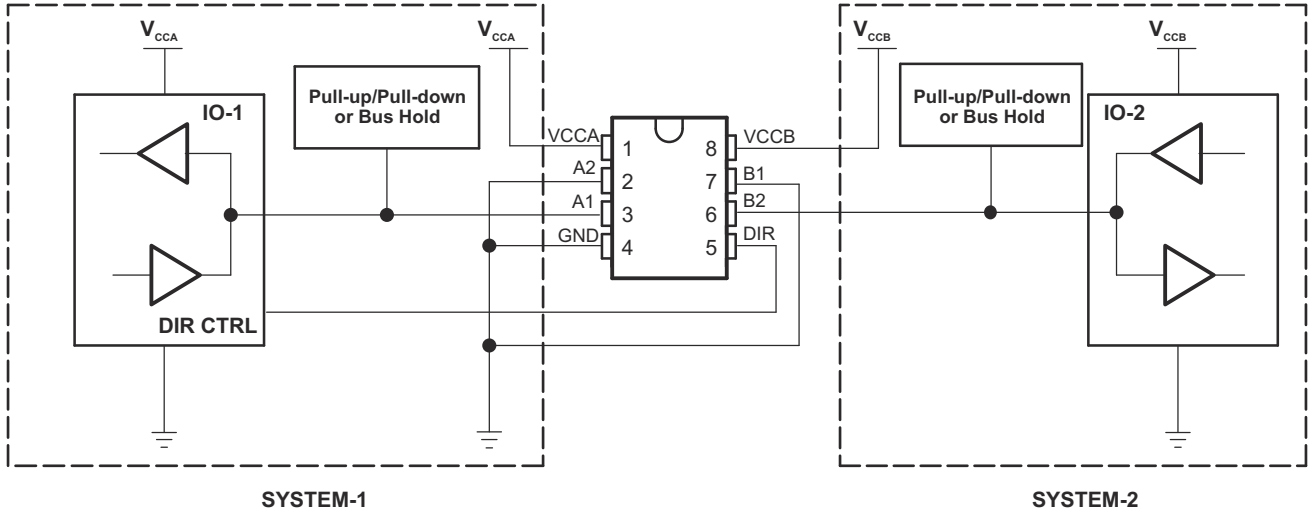

Figure 8-3. Bidirectional Logic Level-Shifting Application

8.2.2.1 Design Requirements

This device uses drivers which are enabled depending on the state of the DIR pin. The designer must know the intended flow of data and take care not to violate any of the high or low logic levels. Active bus-hold circuitry holds unused or un-driven inputs at a valid logic state. TI does not recommend using pull-up or pull-down resistors with the bus-hold circuitry.

8.2.2.2 Detailed Design Procedure

Table 8-2 lists a sequence that shows data transmission from SYSTEM-1 to SYSTEM-2 and then from SYSTEM-2 to SYSTEM-1.

Table 8-2. Data Transmission Sequence

STATE	DIR CTRL	IO-1	IO-2	DESCRIPTION
1	H	Output	Input	SYSTEM-1 data to SYSTEM-2
2	H	Hi-Z	Hi-Z	SYSTEM-2 is getting ready to send data to SYSTEM-1. IO-1 and IO-2 are disabled. The bus-line state depends on pull-up or pull-down. ⁽¹⁾
3	L	Hi-Z	Hi-Z	DIR bit is flipped. IO-1 and IO-2 still are disabled. The bus-line state depends on pull-up or pull-down. ⁽¹⁾
4	L	Input	Output	SYSTEM-2 data to SYSTEM-1

(1) SYSTEM-1 and SYSTEM-2 must use the same conditions, i.e., both pullup or both pulldown.

8.2.2.2.1 Enable Times

Calculate the enable times for the SN74AVCH2T45 using the following formulas:

$$t_{PZH} \text{ (DIR to A)} = t_{PLZ} \text{ (DIR to B)} + t_{PLH} \text{ (B to A)} \quad (1)$$

$$t_{PZL} \text{ (DIR to A)} = t_{PHZ} \text{ (DIR to B)} + t_{PHL} \text{ (B to A)} \quad (2)$$

$$t_{PZH} \text{ (DIR to B)} = t_{PLZ} \text{ (DIR to A)} + t_{PLH} \text{ (A to B)} \quad (3)$$

$$t_{PZL} \text{ (DIR to B)} = t_{PHZ} \text{ (DIR to A)} + t_{PHL} \text{ (A to B)} \quad (4)$$

In a bidirectional application, these enable times provide the maximum delay from the time the DIR bit is switched until an output is expected. For example, if the SN74AVCH2T45 initially is transmitting from A to B, the DIR bit is switched; the B port of the device must be disabled before presenting it with an input. After the B port has been disabled, an input signal applied to it appears on the corresponding A port after the specified propagation delay.

8.2.2.3 Application Curve

Refer to [Figure 8-2](#).

8.3 Power Supply Recommendations

A proper power-up sequence always should be followed to avoid excessive supply current, bus contention, oscillations, or other anomalies. To guard against such power-up problems, take the following precautions:

1. Connect ground before any supply voltage is applied.
2. Power up V_{CCA} .
3. V_{CCB} can be ramped up along with or after V_{CCA} .

Table 8-3. Typical Total Static Power Consumption ($I_{CCA} + I_{CCB}$)

V_{CCB}	V_{CCA}						UNIT
	0V	1.2V	1.5V	1.8V	2.5V	3.3V	
0V	0	< 0.5	< 0.5	< 0.5	< 0.5	< 0.5	μA
1.2V	< 0.5	< 1	< 1	< 1	< 1	1	
1.5V	< 0.5	< 1	< 1	< 1	< 1	1	
1.8V	< 0.5	< 1	< 1	< 1	< 1	< 1	
2.5V	< 0.5	1	< 1	< 1	< 1	< 1	
3.3V	< 0.5	1	< 1	< 1	< 1	< 1	

8.4 Layout

8.4.1 Layout Guidelines

To ensure reliability of the device, following common printed-circuit board layout guidelines is recommended.

- Bypass capacitors should be used on power supplies. Place the capacitors as close as possible to the V_{CCA} , V_{CCB} pin and GND pin.
- Short trace lengths should be used to avoid excessive loading.

8.4.2 Layout Example

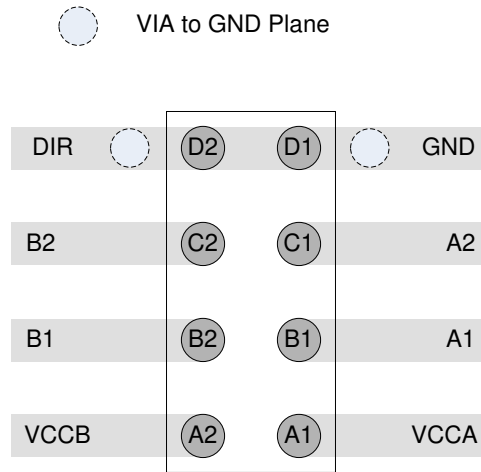

Figure 8-4. Layout Example for YZP Package

9 Device and Documentation Support

9.1 Documentation Support

9.1.1 Related Documentation

For related documentation see the following:

- *Implications of Slow or Floating CMOS Inputs*, [SCBA004](#)

9.2 Receiving Notification of Documentation Updates

To receive notification of documentation updates, navigate to the device product folder on [ti.com](#). Click on *Notifications* to register and receive a weekly digest of any product information that has changed. For change details, review the revision history included in any revised document.

9.3 Support Resources

[TI E2E™ support forums](#) are an engineer's go-to source for fast, verified answers and design help — straight from the experts. Search existing answers or ask your own question to get the quick design help you need.

Linked content is provided "AS IS" by the respective contributors. They do not constitute TI specifications and do not necessarily reflect TI's views; see TI's [Terms of Use](#).

9.4 Trademarks

NanoFree™ and TI E2E™ are trademarks of Texas Instruments.

All trademarks are the property of their respective owners.

9.5 Electrostatic Discharge Caution



This integrated circuit can be damaged by ESD. Texas Instruments recommends that all integrated circuits be handled with appropriate precautions. Failure to observe proper handling and installation procedures can cause damage.

ESD damage can range from subtle performance degradation to complete device failure. Precision integrated circuits may be more susceptible to damage because very small parametric changes could cause the device not to meet its published specifications.

9.6 Glossary

[TI Glossary](#)

This glossary lists and explains terms, acronyms, and definitions.

10 Revision History

NOTE: Page numbers for previous revisions may differ from page numbers in the current version.

Changes from Revision H (April 2015) to Revision I (February 2025)	Page
• Updated the numbering format for tables, figures, and cross-references throughout the document.....	1
• Updated DCT and DCU <i>Thermal Information</i>	6
• Added the <i>Receiving Notifications of Documentation Updates, Support Resources, Electrostatic Discharge Caution, and Glossary</i> sections.....	20

Changes from Revision G (April 2015) to Revision H (April 2015)	Page
• Added additional applications.....	1
• Updated Overview section.	13
• Updated Layout Guidelines section.	18

Changes from Revision F (November 2007) to Revision G (February 2015)	Page
• Added <i>ESD Ratings</i> table, <i>Feature Description</i> section, <i>Device Functional Modes, Application and Implementation</i> section, <i>Power Supply Recommendations</i> section, <i>Layout</i> section, <i>Device and Documentation Support</i> section, and <i>Mechanical, Packaging, and Orderable Information</i> section	1

11 Mechanical, Packaging, and Orderable Information

The following pages include mechanical, packaging, and orderable information. This information is the most current data available for the designated devices. This data is subject to change without notice and revision of this document. For browser-based versions of this data sheet, refer to the left-hand navigation.

PACKAGING INFORMATION

Orderable Device	Status (1)	Package Type	Package Drawing	Pins	Package Qty	Eco Plan (2)	Lead finish/ Ball material (6)	MSL Peak Temp (3)	Op Temp (°C)	Device Marking (4/5)	Samples
74AVCH2T45DCTTE4	ACTIVE	SSOP	DCT	8	250	RoHS & Green	NIPDAU	Level-1-260C-UNLIM	-40 to 85	ET2 Z	Samples
SN74AVCH2T45DCTR	ACTIVE	SSOP	DCT	8	3000	RoHS & Green	NIPDAU	Level-1-260C-UNLIM	-40 to 85	ET2 Z	Samples
SN74AVCH2T45DCTT	ACTIVE	SSOP	DCT	8	250	RoHS & Green	NIPDAU	Level-1-260C-UNLIM	-40 to 85	ET2 Z	Samples
SN74AVCH2T45DCUR	ACTIVE	VSSOP	DCU	8	3000	RoHS & Green	NIPDAU SN	Level-1-260C-UNLIM	-40 to 85	(ET2R, T2) EZ	Samples
SN74AVCH2T45DCURG4	ACTIVE	VSSOP	DCU	8	3000	RoHS & Green	NIPDAU	Level-1-260C-UNLIM	-40 to 85	ET2R	Samples
SN74AVCH2T45DCUT	ACTIVE	VSSOP	DCU	8	250	RoHS & Green	NIPDAU SN	Level-1-260C-UNLIM	-40 to 85	(ET2R, T2) EZ	Samples
SN74AVCH2T45YZPR	ACTIVE	DSBGA	YZP	8	3000	RoHS & Green	SNAGCU	Level-1-260C-UNLIM	-40 to 85	TFN	Samples

(1) The marketing status values are defined as follows:

ACTIVE: Product device recommended for new designs.

LIFEBUY: TI has announced that the device will be discontinued, and a lifetime-buy period is in effect.

NRND: Not recommended for new designs. Device is in production to support existing customers, but TI does not recommend using this part in a new design.

PREVIEW: Device has been announced but is not in production. Samples may or may not be available.

OBSOLETE: TI has discontinued the production of the device.

(2) **RoHS:** TI defines "RoHS" to mean semiconductor products that are compliant with the current EU RoHS requirements for all 10 RoHS substances, including the requirement that RoHS substance do not exceed 0.1% by weight in homogeneous materials. Where designed to be soldered at high temperatures, "RoHS" products are suitable for use in specified lead-free processes. TI may reference these types of products as "Pb-Free".

RoHS Exempt: TI defines "RoHS Exempt" to mean products that contain lead but are compliant with EU RoHS pursuant to a specific EU RoHS exemption.

Green: TI defines "Green" to mean the content of Chlorine (Cl) and Bromine (Br) based flame retardants meet JS709B low halogen requirements of <=1000ppm threshold. Antimony trioxide based flame retardants must also meet the <=1000ppm threshold requirement.

(3) MSL, Peak Temp. - The Moisture Sensitivity Level rating according to the JEDEC industry standard classifications, and peak solder temperature.

(4) There may be additional marking, which relates to the logo, the lot trace code information, or the environmental category on the device.

(5) Multiple Device Markings will be inside parentheses. Only one Device Marking contained in parentheses and separated by a "~" will appear on a device. If a line is indented then it is a continuation of the previous line and the two combined represent the entire Device Marking for that device.

⁽⁶⁾ Lead finish/Ball material - Orderable Devices may have multiple material finish options. Finish options are separated by a vertical ruled line. Lead finish/Ball material values may wrap to two lines if the finish value exceeds the maximum column width.

Important Information and Disclaimer:The information provided on this page represents TI's knowledge and belief as of the date that it is provided. TI bases its knowledge and belief on information provided by third parties, and makes no representation or warranty as to the accuracy of such information. Efforts are underway to better integrate information from third parties. TI has taken and continues to take reasonable steps to provide representative and accurate information but may not have conducted destructive testing or chemical analysis on incoming materials and chemicals. TI and TI suppliers consider certain information to be proprietary, and thus CAS numbers and other limited information may not be available for release.

In no event shall TI's liability arising out of such information exceed the total purchase price of the TI part(s) at issue in this document sold by TI to Customer on an annual basis.

TAPE AND REEL INFORMATION

QUADRANT ASSIGNMENTS FOR PIN 1 ORIENTATION IN TAPE

*All dimensions are nominal

Device	Package Type	Package Drawing	Pins	SPQ	Reel Diameter (mm)	Reel Width W1 (mm)	A0 (mm)	B0 (mm)	K0 (mm)	P1 (mm)	W (mm)	Pin1 Quadrant
SN74AVCH2T45DCTR	SSOP	DCT	8	3000	180.0	13.0	3.35	4.5	1.55	4.0	12.0	Q3
SN74AVCH2T45DCTT	SSOP	DCT	8	250	180.0	13.0	3.35	4.5	1.55	4.0	12.0	Q3
SN74AVCH2T45DCUR	VSSOP	DCU	8	3000	180.0	9.0	2.25	3.4	1.0	4.0	8.0	Q3
SN74AVCH2T45DCURG4	VSSOP	DCU	8	3000	180.0	8.4	2.25	3.35	1.05	4.0	8.0	Q3
SN74AVCH2T45YZPR	DSBGA	YZP	8	3000	178.0	9.2	1.02	2.02	0.63	4.0	8.0	Q1

TAPE AND REEL BOX DIMENSIONS

*All dimensions are nominal

Device	Package Type	Package Drawing	Pins	SPQ	Length (mm)	Width (mm)	Height (mm)
SN74AVCH2T45DCTR	SSOP	DCT	8	3000	182.0	182.0	20.0
SN74AVCH2T45DCTT	SSOP	DCT	8	250	182.0	182.0	20.0
SN74AVCH2T45DCUR	VSSOP	DCU	8	3000	182.0	182.0	20.0
SN74AVCH2T45DCURG4	VSSOP	DCU	8	3000	202.0	201.0	28.0
SN74AVCH2T45YZPR	DSBGA	YZP	8	3000	220.0	220.0	35.0

IMPORTANT NOTICE AND DISCLAIMER

TI PROVIDES TECHNICAL AND RELIABILITY DATA (INCLUDING DATA SHEETS), DESIGN RESOURCES (INCLUDING REFERENCE DESIGNS), APPLICATION OR OTHER DESIGN ADVICE, WEB TOOLS, SAFETY INFORMATION, AND OTHER RESOURCES "AS IS" AND WITH ALL FAULTS, AND DISCLAIMS ALL WARRANTIES, EXPRESS AND IMPLIED, INCLUDING WITHOUT LIMITATION ANY IMPLIED WARRANTIES OF MERCHANTABILITY, FITNESS FOR A PARTICULAR PURPOSE OR NON-INFRINGEMENT OF THIRD PARTY INTELLECTUAL PROPERTY RIGHTS.

These resources are intended for skilled developers designing with TI products. You are solely responsible for (1) selecting the appropriate TI products for your application, (2) designing, validating and testing your application, and (3) ensuring your application meets applicable standards, and any other safety, security, regulatory or other requirements.

These resources are subject to change without notice. TI grants you permission to use these resources only for development of an application that uses the TI products described in the resource. Other reproduction and display of these resources is prohibited. No license is granted to any other TI intellectual property right or to any third party intellectual property right. TI disclaims responsibility for, and you will fully indemnify TI and its representatives against, any claims, damages, costs, losses, and liabilities arising out of your use of these resources.

TI's products are provided subject to [TI's Terms of Sale](#) or other applicable terms available either on [ti.com](https://www.ti.com) or provided in conjunction with such TI products. TI's provision of these resources does not expand or otherwise alter TI's applicable warranties or warranty disclaimers for TI products.

TI objects to and rejects any additional or different terms you may have proposed.

Mailing Address: Texas Instruments, Post Office Box 655303, Dallas, Texas 75265

Copyright © 2025, Texas Instruments Incorporated