

# SN74AXC1T45 可変電圧変換の 1 ビット・デュアル電源バス・トランシーバ

## 1 特長

- 0.65 V～3.6V の昇圧および降圧変換
- 動作温度: -40°C～+125°C
- グリッチ抑制回路が設計に組み込まれており、電源シーケンス特性が向上
- 最大静止電流 ( $I_{CCA} + I_{CCB}$ ): 10 $\mu$ A (最高 85°C) および 16 $\mu$ A (最高 125°C)
- 1.8V から 3.3V への変換時に最高 500Mbps をサポート
- $V_{CC}$  絶縁機能:
  - どちらかの  $V_{CC}$  入力が 100mV を下回った場合、すべての I/O 出力がディセーブルされ高インピーダンス状態に移行
- $I_{off}$  により部分的パワーダウン モードでの動作をサポート
- JESD 78、Class II 準拠で 100mA 超のラッチアップ性能
- JESD 22 を上回る ESD 保護:
  - 人体モデルで 8000V
  - デバイス帯電モデルで 1000V

## 2 アプリケーション

- エンタープライズおよび通信
- 産業用
- パーソナル エレクトロニクス

## 3 概要

SN74AXC1T45 は、個別に設定可能な 2 つの電源レールを使用した 1 ビット非反転バス トランシーバです。このデバイスは、 $V_{CCA}$  電源と  $V_{CCB}$  電源の両方が最低 0.65V で動作します。A ポートは  $V_{CCA}$  (0.65V～3.6V の任意の電源電圧を入力できます) に追従するように設計されています。同様に B ポートは  $V_{CCB}$  (0.65V～3.6V の任意の電源電圧を入力できます) に追従するように設計されています。

信号伝搬の方向は DIR ピンを使用して制御します。DIR ピンを HIGH に設定するとポート A からポート B への変換になり、DIR ピンを LOW に設定するとポート B からポート A への変換になります。DIR ピンは  $V_{CCA}$  を基準とすることから、そのロジック HIGH とロジック LOW のスレッシュホールドは  $V_{CCA}$  に追従します。

このデバイスは、 $I_{off}$  電流を使用する部分的パワーダウンアプリケーション用に完全に動作が規定されています。 $I_{off}$  保護回路により、電源切断時に入力、出力、複合 I/O は指定の電圧にバイアスされ、それらとの間に過剰な電流が流れることはありません。

$V_{CC}$  絶縁機能により、 $V_{CCA}$  と  $V_{CCB}$  のどちらかが 100mV を下回ると、両方の出力がディセーブルになり、両方の I/O ポートが高インピーダンス状態になります。

グリッチ抑制回路により、両方の電源レールをどのような順序で電源オンまたはオフにしてもかまわないため、堅牢な電源シーケンス性能が得られます。

### 製品情報

部品番号 (1)	パッケージ	パッケージ サイズ(2)
SN74AXC1T45	DBV (SOT-23, 6)	2.9mm × 2.8mm
	DCK (SC70, 6)	2mm × 2.1mm
	DRL (SOT-5X3, 6)	1.6mm × 1.6mm
	DEA (X2SON, 6)	1mm × 1mm
	DTQ (X2SON, 6)	1mm × 0.8mm

- (1) 詳細については、[セクション 11](#) を参照してください。
- (2) パッケージ サイズ (長さ × 幅) は公称値であり、該当する場合はピンも含まれます。

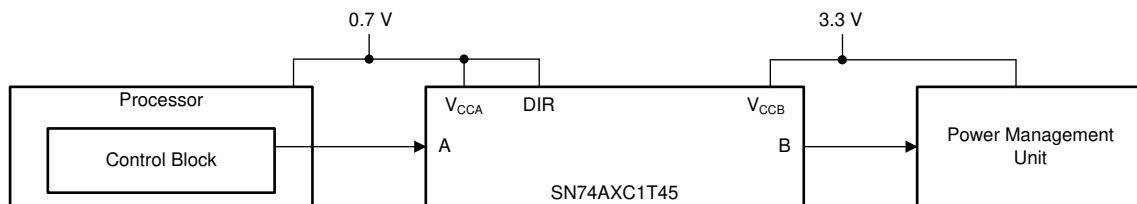

概略回路図



## Table of Contents

<b>1 特長</b> .....	1	7.3 Feature Description.....	17
<b>2 アプリケーション</b> .....	1	7.4 Device Functional Modes.....	18
<b>3 概要</b> .....	1	<b>8 Application and Implementation</b> .....	19
<b>4 Pin Configuration and Functions</b> .....	3	8.1 Application Information.....	19
<b>5 Specifications</b> .....	4	8.2 Typical Applications.....	19
5.1 Absolute Maximum Ratings.....	4	8.3 Power Supply Recommendations.....	22
5.2 ESD Ratings.....	4	8.4 Layout.....	22
5.3 Recommended Operating Conditions.....	5	<b>9 Device and Documentation Support</b> .....	24
5.4 Thermal Information.....	5	9.1 Documentation Support.....	24
5.5 Electrical Characteristics.....	6	9.2 ドキュメントの更新通知を受け取る方法.....	24
5.6 Switching Characteristics.....	7	9.3 サポート・リソース.....	24
5.7 Operating Characteristics: T <sub>A</sub> = 25°C.....	11	9.4 Trademarks.....	24
5.8 Typical Characteristics.....	12	9.5 静電気放電に関する注意事項.....	24
<b>6 Parameter Measurement Information</b> .....	15	9.6 用語集.....	24
6.1 Load Circuit and Voltage Waveforms.....	15	<b>10 Revision History</b> .....	24
<b>7 Detailed Description</b> .....	17	<b>11 Mechanical, Packaging, and Orderable Information</b> .....	25
7.1 Overview.....	17		
7.2 Functional Block Diagram.....	17		

## 4 Pin Configuration and Functions



図 4-1. DBV Package  
6-Pin SOT-23  
(Top View)



図 4-3. DRL Package  
6-Pin SOT-5X3  
(Top View)

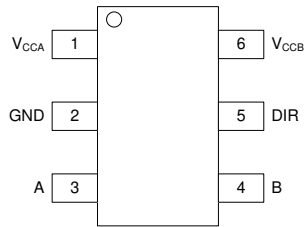

図 4-2. DCK Package  
6-Pin SC70  
(Top View)

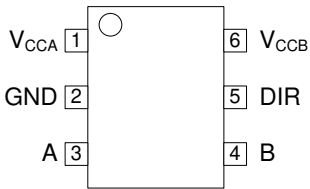

図 4-4. DEA Package  
6-Pin X2SON  
(Transparent Top View)

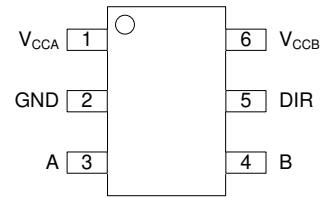

図 4-5. DTQ Package  
6-Pin X2SON  
(Transparent Top View)

表 4-1. Pin Functions

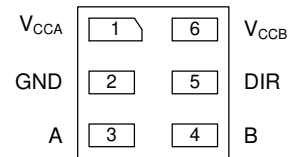
PIN		TYPE	DESCRIPTION
NAME	NO.		
A	3	I/O	Input or output A. This pin is referenced to $V_{CCA}$ . When this pin is configured as an input, do not leave it floating.
B	4	I/O	Input or output B. This pin is referenced to $V_{CCB}$ . When this pin is configured as an input, do not leave it floating.
DIR	5	I	Direction control signal. Set to Logic High for A-to-B level translation. Set to Logic Low for B-to-A level translation.
GND	2	—	Ground.
$V_{CCA}$	1	—	A-port supply voltage. $0.65\text{ V} \leq V_{CCA} \leq 3.6\text{ V}$ .
$V_{CCB}$	6	—	B-port supply voltage. $0.65\text{ V} \leq V_{CCB} \leq 3.6\text{ V}$ .

## 5 Specifications

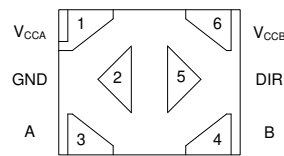
### 5.1 Absolute Maximum Ratings

over operating free-air temperature range (unless otherwise noted)<sup>(1)</sup>

		MIN	MAX	UNIT	
V <sub>CCA</sub>	Supply voltage A	-0.5	4.2	V	
V <sub>CCB</sub>	Supply voltage B	-0.5	4.2	V	
V <sub>I</sub>	Input Voltage <sup>(2)</sup>	I/O Ports (A Port)	-0.5	4.2	V
		I/O Ports (B Port)	-0.5	4.2	
		Control Inputs	-0.5	4.2	
V <sub>O</sub>	Voltage applied to any output in the high-impedance or power-off state <sup>(2)</sup>	A Port	-0.5	4.2	V
		B Port	-0.5	4.2	
V <sub>O</sub>	Voltage applied to any output in the high or low state <sup>(2) (3)</sup>	A Port	-0.5 V <sub>CCA</sub> + 0.2		V
		B Port	-0.5 V <sub>CCB</sub> + 0.2		
I <sub>IK</sub>	Input clamp current	V <sub>I</sub> < 0	-50	mA	
I <sub>OK</sub>	Output clamp current	V <sub>O</sub> < 0	-50	mA	
I <sub>O</sub>	Continuous output current		-50	50	mA
	Continuous current through V <sub>CC</sub> or GND		-100	100	mA
T <sub>J</sub>	Junction Temperature			150	°C
T <sub>STG</sub>	Storage temperature		-65	150	°C

- (1) Stresses beyond those listed under *Absolute Maximum Ratings* may cause permanent damage to the device. These are stress ratings only, which do not imply functional operation of the device at these or any other conditions beyond those indicated under *Recommended Operating Conditions*. Exposure to absolute-maximum-rated conditions for extended periods may affect device reliability.
- (2) The input voltage and output negative-voltage ratings may be exceeded if the input and output current ratings are observed.
- (3) The output positive-voltage rating may be exceeded up to 4.2V maximum if the output current rating is observed.

### 5.2 ESD Ratings

		VALUE	UNIT	
V <sub>(ESD)</sub>	Electrostatic discharge	Human-body model (HBM), per ANSI/ESDA/JEDEC JS-001 <sup>(1)</sup>	±8000	V
		Charged-device model (CDM), per JEDEC specification JESD22-C101 <sup>(2)</sup>	±1000	

- (1) JEDEC document JEP155 states that 500-V HBM allows safe manufacturing with a standard ESD control process.
- (2) JEDEC document JEP157 states that 250-V CDM allows safe manufacturing with a standard ESD control process.

### 5.3 Recommended Operating Conditions

over operating free-air temperature range (unless otherwise noted)<sup>(1)</sup> <sup>(2)</sup> <sup>(3)</sup>

		MIN	MAX	UNIT	
V <sub>CCA</sub>	Supply voltage A	0.65	3.6	V	
V <sub>CCB</sub>	Supply voltage B	0.65	3.6	V	
V <sub>IH</sub>	High-level input voltage	Data Inputs	V <sub>CCI</sub> = 0.65 V - 0.75 V	V <sub>CCI</sub> × 0.70	V
			V <sub>CCI</sub> = 0.76 V - 1V	V <sub>CCI</sub> × 0.70	
			V <sub>CCI</sub> = 1.1V - 1.95 V	V <sub>CCI</sub> × 0.65	
			V <sub>CCI</sub> = 2.3V - 2.7V	1.6	
			V <sub>CCI</sub> = 3V - 3.6V	2	
		Control Input (DIR) Referenced to V <sub>CCA</sub>	V <sub>CCA</sub> = 0.65 V - 0.75 V	V <sub>CCA</sub> × 0.70	
			V <sub>CCA</sub> = 0.76 V - 1V	V <sub>CCA</sub> × 0.70	
			V <sub>CCA</sub> = 1.1V - 1.95 V	V <sub>CCA</sub> × 0.65	
			V <sub>CCA</sub> = 2.3V - 2.7V	1.6	
			V <sub>CCA</sub> = 3V - 3.6V	2	
V <sub>IL</sub>	Low-level input voltage	Data Inputs	V <sub>CCI</sub> = 0.65 V - 0.75 V	V <sub>CCI</sub> × 0.30	V
			V <sub>CCI</sub> = 0.76 V - 1V	V <sub>CCI</sub> × 0.30	
			V <sub>CCI</sub> = 1.1V - 1.95 V	V <sub>CCI</sub> × 0.35	
			V <sub>CCI</sub> = 2.3V - 2.7V	0.7	
			V <sub>CCI</sub> = 3V - 3.6V	0.8	
		Control Input (DIR) Referenced to V <sub>CCA</sub>	V <sub>CCA</sub> = 0.65 V - 0.75 V	V <sub>CCA</sub> × 0.30	
			V <sub>CCA</sub> = 0.76 V - 1V	V <sub>CCA</sub> × 0.30	
			V <sub>CCA</sub> = 1.1V - 1.95 V	V <sub>CCA</sub> × 0.35	
			V <sub>CCA</sub> = 2.3V - 2.7V	0.7	
			V <sub>CCA</sub> = 3V - 3.6V	0.8	
V <sub>I</sub>	Input voltage <sup>(3)</sup>	0	3.6	V	
V <sub>O</sub>	Output voltage	Active State	0	V <sub>CCO</sub>	V
		Tri-State	0	3.6	
Δt/Δv	Input transition rate		100	ns/V	
T <sub>A</sub>	Operating free-air temperature	-40	125	°C	

(1) V<sub>CCI</sub> is the VCC associated with the input port.

(2) V<sub>CCO</sub> is the VCC associated with the output port.

(3) All unused inputs of the device must be held at VCC or GND to ensure proper device operation. Refer to the TI application report, [Implications of Slow or Floating CMOS Inputs](#).

### 5.4 Thermal Information

THERMAL METRIC <sup>(1)</sup>	SN74AXC1T45					UNIT	
	DBV (SOT-23)	DCK (SC70)	DRL (SOT-5X3)	DEA (X2SON)	DTQ (X2SON)		
	6 PINS	6 PINS	6 PINS	6 PINS	6 PINS		
R <sub>θJA</sub>	Junction-to-ambient thermal resistance	202.2	235.3	298.9	358.0	327.8	°C/W
R <sub>θJC(top)</sub>	Junction-to-case (top) thermal resistance	137.2	160.5	148.4	201.0	194.9	°C/W
R <sub>θJB</sub>	Junction-to-board thermal resistance	80.2	76.9	165.0	221.8	248.4	°C/W
ψ <sub>JT</sub>	Junction-to-top characterization parameter	64.0	59.7	20.7	26.1	24.1	°C/W
ψ <sub>JB</sub>	Junction-to-board characterization parameter	80.4	77.1	164.9	220.8	247.6	°C/W

(1) For more information about traditional and new thermal metrics, see the [Semiconductor and IC Package Thermal Metrics application report](#).

## 5.5 Electrical Characteristics

over operating free-air temperature range (unless otherwise noted) <sup>(1)</sup> <sup>(2)</sup>

PARAMETER	TEST CONDITIONS	V <sub>CCA</sub>	V <sub>CCB</sub>	Operating free-air temperature (T <sub>A</sub> )						UNIT
				-40°C to 85°C			-40°C to 125°C			
				MIN	TYP <sup>(3)</sup>	MAX	MIN	TYP	MAX	
V <sub>OH</sub>	High-level output voltage	V <sub>I</sub> = V <sub>IH</sub>	I <sub>OH</sub> = -100μA	0.7V - 3.6V	0.7V - 3.6V	V <sub>CCO</sub> - 0.1			V	
			I <sub>OH</sub> = -50μA	0.65 V	0.65 V	0.55				
			I <sub>OH</sub> = -200μA	0.76 V	0.76 V	0.58				
			I <sub>OH</sub> = -500μA	0.85 V	0.85 V	0.65				
			I <sub>OH</sub> = -3mA	1.1V	1.1V	0.85				
			I <sub>OH</sub> = -6mA	1.4V	1.4V	1.05				
			I <sub>OH</sub> = -8mA	1.65 V	1.65 V	1.2				
			I <sub>OH</sub> = -9mA	2.3V	2.3V	1.75				
			I <sub>OH</sub> = -12mA	3V	3V	2.3				
V <sub>OL</sub>	Low-level output voltage	V <sub>I</sub> = V <sub>IL</sub>	I <sub>OL</sub> = 100μA	0.7V - 3.6V	0.7V - 3.6V	0.1			V	
			I <sub>OL</sub> = 50μA	0.65 V	0.65 V	0.1				
			I <sub>OL</sub> = 200μA	0.76 V	0.76 V	0.18				
			I <sub>OL</sub> = 500μA	0.85 V	0.85 V	0.2				
			I <sub>OL</sub> = 3mA	1.1V	1.1V	0.25				
			I <sub>OL</sub> = 6mA	1.4V	1.4V	0.35				
			I <sub>OL</sub> = 8mA	1.65 V	1.65 V	0.45				
			I <sub>OL</sub> = 9mA	2.3V	2.3V	0.55				
			I <sub>OL</sub> = 12mA	3V	3V	0.7				
I <sub>I</sub>	Input leakage current	Control input (DIR): V <sub>I</sub> = V <sub>CCA</sub> or GND		0.65 V- 3.6V	0.65 V- 3.6V	-1	1	-1.5	1.5	μA
		A or B Port: V <sub>I</sub> = V <sub>CCI</sub> or GND		0.65 V- 3.6V	0.65 V- 3.6V	-4	4	-8	8	
I <sub>off</sub>	Partial power down current	A or B Port: V <sub>I</sub> or V <sub>O</sub> = 0V - 3.6V		0V	0V - 3.6V	-5	5	-7.5	7.5	μA
				0V - 3.6V	0V	-5	5	-7.5	7.5	
I <sub>CCA</sub>	V <sub>CCA</sub> supply current	V <sub>I</sub> = V <sub>CCI</sub> or GND	I <sub>O</sub> = 0	0.65 V- 3.6V	0.65 V- 3.6V	8			μA	
				0V	3.6V	-2				
				3.6V	0V	2				
I <sub>CCB</sub>	V <sub>CCB</sub> supply current	V <sub>I</sub> = V <sub>CCI</sub> or GND	I <sub>O</sub> = 0	0.65 V- 3.6V	0.65 V- 3.6V	8			μA	
				0V	3.6V	2				
				3.6V	0V	-2				
I <sub>CCA</sub> + I <sub>CCB</sub>	Combined supply current	V <sub>I</sub> = V <sub>CCI</sub> or GND	I <sub>O</sub> = 0	0.65 V- 3.6V	0.65 V- 3.6V	10			16	μA
C <sub>I</sub>	Control input capacitance	V <sub>I</sub> = 3.3V or GND		3.3V	3.3V	4.4			4.4	pF
C <sub>IO</sub>	Data I/O capacitance, A Port	V <sub>O</sub> = 1.65V DC +1 MHz -16 dBm sine wave		3.3V	0V	5			5	pF
C <sub>IO</sub>	Data I/O capacitance, B Port	V <sub>O</sub> = 1.65V DC +1 MHz -16 dBm sine wave		0V	3.3V	5			5	pF

- (1) V<sub>CCI</sub> is the VCC associated with the input port.  
(2) V<sub>CCO</sub> is the VCC associated with the output port.  
(3) All typical data is taken at 25°C.

## 5.6 Switching Characteristics

表 5-1. Switching Characteristics,  $V_{CCA} = 0.7V$

PARAMETER	FROM	TO	TEST CONDITIONS	B-PORIT SUPPLY VOLTAGE ( $V_{CCB}$ )														UNIT		
				0.7 ± 0.05 V		0.8 ± 0.04 V		0.9 ± 0.045 V		1.2 ± 0.1V		1.5 ± 0.1V		1.8 ± 0.15 V		2.5 ± 0.2V			3.3 ± 0.3V	
				MIN	MAX	MIN	MAX	MIN	MAX	MIN	MAX	MIN	MAX	MIN	MAX	MIN	MAX		MIN	MAX
$t_{pd}$ Propagation delay	A	B	-40°C to 85°C	0.5	173	0.5	117	0.5	85	0.5	51	0.5	50	0.5	53	0.5	65	0.5	143	ns
			-40°C to 125°C	0.5	173	0.5	117	0.5	85	0.5	51	0.5	50	0.5	53	0.5	65	0.5	143	
	B	A	-40°C to 85°C	0.5	173	0.5	154	0.5	127	0.5	88	0.5	83	0.5	82	0.5	80	0.5	80	
			-40°C to 125°C	0.5	173	0.5	154	0.5	127	0.5	88	0.5	83	0.5	82	0.5	80	0.5	80	
$t_{dis}$ Disable time	DIR	A	-40°C to 85°C	0.5	143	0.5	143	0.5	143	0.5	143	0.5	143	0.5	143	0.5	143	0.5	143	ns
			-40°C to 125°C	0.5	143	0.5	143	0.5	143	0.5	143	0.5	143	0.5	143	0.5	143	0.5	143	
	DIR	B	-40°C to 85°C	0.5	163	0.5	123	0.5	100	0.5	50	0.5	45	0.5	49	0.5	61	0.5	109	
			-40°C to 125°C	0.5	163	0.5	123	0.5	100	0.5	50	0.5	45	0.5	49	0.5	61	0.5	109	
$t_{en}$ Enable time	DIR	A	-40°C to 85°C	0.5	389	0.5	331	0.5	287	0.5	143	0.5	134	0.5	137	0.5	147	0.5	200	ns
			-40°C to 125°C	0.5	406	0.5	333	0.5	287	0.5	143	0.5	134	0.5	137	0.5	147	0.5	200	
	DIR	B	-40°C to 85°C	0.5	369	0.5	313	0.5	281	0.5	247	0.5	246	0.5	249	0.5	261	0.5	339	
			-40°C to 125°C	0.5	395	0.5	339	0.5	307	0.5	273	0.5	272	0.5	275	0.5	287	0.5	365	

表 5-2. Switching Characteristics,  $V_{CCA} = 0.8V$

PARAMETER	FROM	TO	TEST CONDITIONS	B-PORIT SUPPLY VOLTAGE ( $V_{CCB}$ )														UNIT		
				0.7 ± 0.05 V		0.8 ± 0.04 V		0.9 ± 0.045 V		1.2 ± 0.1V		1.5 ± 0.1V		1.8 ± 0.15 V		2.5 ± 0.2V			3.3 ± 0.3V	
				MIN	MAX	MIN	MAX	MIN	MAX	MIN	MAX	MIN	MAX	MIN	MAX	MIN	MAX		MIN	MAX
$t_{pd}$ Propagation delay	A	B	-40°C to 85°C	0.5	153	0.5	95	0.5	64	0.5	33	0.5	27	0.5	26	0.5	27	0.5	36	ns
			-40°C to 125°C	0.5	153	0.5	95	0.5	64	0.5	33	0.5	27	0.5	26	0.5	27	0.5	36	
	B	A	-40°C to 85°C	0.5	117	0.5	96	0.5	78	0.5	52	0.5	42	0.5	41	0.5	40	0.5	39	
			-40°C to 125°C	0.5	117	0.5	96	0.5	78	0.5	52	0.5	42	0.5	41	0.5	40	0.5	39	
$t_{dis}$ Disable time	DIR	A	-40°C to 85°C	0.5	100	0.5	100	0.5	100	0.5	100	0.5	100	0.5	100	0.5	100	0.5	100	ns
			-40°C to 125°C	0.5	100	0.5	100	0.5	100	0.5	100	0.5	100	0.5	100	0.5	100	0.5	100	
	DIR	B	-40°C to 85°C	0.5	151	0.5	111	0.5	88	0.5	38	0.5	32	0.5	30	0.5	30	0.5	38	
			-40°C to 125°C	0.5	151	0.5	111	0.5	88	0.5	38	0.5	32	0.5	30	0.5	30	0.5	38	
$t_{en}$ Enable time	DIR	A	-40°C to 85°C	0.5	321	0.5	261	0.5	226	0.5	96	0.5	80	0.5	78	0.5	76	0.5	87	ns
			-40°C to 125°C	0.5	341	0.5	266	0.5	229	0.5	97	0.5	80	0.5	78	0.5	76	0.5	87	
	DIR	B	-40°C to 85°C	0.5	309	0.5	251	0.5	220	0.5	189	0.5	183	0.5	182	0.5	183	0.5	192	
			-40°C to 125°C	0.5	317	0.5	259	0.5	228	0.5	197	0.5	191	0.5	190	0.5	191	0.5	200	

表 5-3. Switching Characteristics,  $V_{CCA} = 0.9V$ 

PARAMETER	FROM	TO	TEST CONDITIONS	B–PORT SUPPLY VOLTAGE ( $V_{CCB}$ )														UNIT		
				0.7 ± 0.05 V		0.8 ± 0.04 V		0.9 ± 0.045 V		1.2 ± 0.1V		1.5 ± 0.1V		1.8 ± 0.15 V		2.5 ± 0.2V			3.3 ± 0.3V	
				MIN	MAX	MIN	MAX	MIN	MAX	MIN	MAX	MIN	MAX	MIN	MAX	MIN	MAX		MIN	MAX
$t_{pd}$ Propagation delay	A	B	–40°C to 85°C	0.5	126	0.5	78	0.5	52	0.5	23	0.5	18	0.5	16	0.5	15	0.5	18	ns
			–40°C to 125°C	0.5	126	0.5	78	0.5	52	0.5	23	0.5	18	0.5	16	0.5	15	0.5	18	
	B	A	–40°C to 85°C	0.5	85	0.5	64	0.5	53	0.5	40	0.5	28	0.5	24	0.5	22	0.5	21	
			–40°C to 125°C	0.5	85	0.5	64	0.5	53	0.5	40	0.5	28	0.5	24	0.5	22	0.5	21	
$t_{dis}$ Disable time	DIR	A	–40°C to 85°C	0.5	75	0.5	75	0.5	75	0.5	75	0.5	75	0.5	75	0.5	75	0.5	75	ns
			–40°C to 125°C	0.5	79	0.5	79	0.5	79	0.5	79	0.5	79	0.5	79	0.5	79	0.5	79	
	DIR	B	–40°C to 85°C	0.5	144	0.5	105	0.5	82	0.5	32	0.5	25	0.5	24	0.5	21	0.5	23	
			–40°C to 125°C	0.5	144	0.5	105	0.5	83	0.5	36	0.5	28	0.5	26	0.5	21	0.5	23	
$t_{en}$ Enable time	DIR	A	–40°C to 85°C	0.5	282	0.5	223	0.5	195	0.5	77	0.5	59	0.5	54	0.5	48	0.5	54	ns
			–40°C to 125°C	0.5	304	0.5	229	0.5	199	0.5	81	0.5	62	0.5	56	0.5	49	0.5	54	
	DIR	B	–40°C to 85°C	0.5	262	0.5	214	0.5	188	0.5	159	0.5	154	0.5	152	0.5	151	0.5	154	
			–40°C to 125°C	0.5	269	0.5	221	0.5	195	0.5	166	0.5	161	0.5	159	0.5	158	0.5	161	

表 5-4. Switching Characteristics,  $V_{CCA} = 1.2V$ 

PARAMETER	FROM	TO	TEST CONDITIONS	B–PORT SUPPLY VOLTAGE ( $V_{CCB}$ )														UNIT		
				0.7 ± 0.05 V		0.8 ± 0.04 V		0.9 ± 0.045 V		1.2 ± 0.1V		1.5 ± 0.1V		1.8 ± 0.15 V		2.5 ± 0.2V			3.3 ± 0.3V	
				MIN	MAX	MIN	MAX	MIN	MAX	MIN	MAX	MIN	MAX	MIN	MAX	MIN	MAX		MIN	MAX
$t_{pd}$ Propagation delay	A	B	–40°C to 85°C	0.5	87	0.5	52	0.5	39	0.5	15	0.5	9	0.5	8	0.5	7	0.5	7	ns
			–40°C to 125°C	0.5	87	0.5	52	0.5	39	0.5	15	0.5	10	0.5	9	0.5	7	0.5	8	
	B	A	–40°C to 85°C	0.5	51	0.5	33	0.5	23	0.5	15	0.5	12	0.5	10	0.5	7	0.5	7	
			–40°C to 125°C	0.5	51	0.5	33	0.5	23	0.5	15	0.5	12	0.5	10	0.5	8	0.5	7	
$t_{dis}$ Disable time	DIR	A	–40°C to 85°C	0.5	22	0.5	22	0.5	22	0.5	22	0.5	22	0.5	22	0.5	22	0.5	22	ns
			–40°C to 125°C	0.5	29	0.5	29	0.5	29	0.5	29	0.5	29	0.5	29	0.5	29	0.5	29	
	DIR	B	–40°C to 85°C	0.5	137	0.5	98	0.5	74	0.5	24	0.5	18	0.5	16	0.5	13	0.5	13	
			–40°C to 125°C	0.5	137	0.5	98	0.5	78	0.5	30	0.5	23	0.5	21	0.5	17	0.5	16	
$t_{en}$ Enable time	DIR	A	–40°C to 85°C	0.5	240	0.5	185	0.5	157	0.5	45	0.5	36	0.5	33	0.5	26	0.5	29	ns
			–40°C to 125°C	0.5	265	0.5	193	0.5	164	0.5	51	0.5	41	0.5	37	0.5	30	0.5	32	
	DIR	B	–40°C to 85°C	0.5	115	0.5	80	0.5	67	0.5	43	0.5	37	0.5	36	0.5	35	0.5	35	
			–40°C to 125°C	0.5	121	0.5	86	0.5	73	0.5	49	0.5	44	0.5	43	0.5	41	0.5	42	



表 5-5. Switching Characteristics,  $V_{CCA} = 1.5V$

PARAMETER	FROM	TO	TEST CONDITIONS	B-PORT SUPPLY VOLTAGE ( $V_{CCB}$ )												UNIT				
				0.7 ± 0.05 V		0.8 ± 0.04 V		0.9 ± 0.045 V		1.2 ± 0.1V		1.5 ± 0.1V		1.8 ± 0.15 V			2.5 ± 0.2V		3.3 ± 0.3V	
				MIN	MAX	MIN	MAX	MIN	MAX	MIN	MAX	MIN	MAX	MIN	MAX		MIN	MAX	MIN	MAX
$t_{pd}$ Propagation delay	A	B	-40°C to 85°C	0.5	83	0.5	42	0.5	28	0.5	12	0.5	8	0.5	7	0.5	5	0.5	5	ns
			-40°C to 125°C	0.5	83	0.5	42	0.5	28	0.5	12	0.5	9	0.5	8	0.5	6	0.5	6	
	B	A	-40°C to 85°C	0.5	50	0.5	28	0.5	18	0.5	10	0.5	8	0.5	7	0.5	5	0.5	4	
			-40°C to 125°C	0.5	50	0.5	28	0.5	18	0.5	10	0.5	9	0.5	8	0.5	6	0.5	5	
$t_{dis}$ Disable time	DIR	A	-40°C to 85°C	0.5	15	0.5	15	0.5	15	0.5	15	0.5	15	0.5	15	0.5	15	0.5	15	ns
			-40°C to 125°C	0.5	20	0.5	20	0.5	20	0.5	20	0.5	20	0.5	20	0.5	20	0.5	20	
	DIR	B	-40°C to 85°C	0.5	136	0.5	96	0.5	72	0.5	22	0.5	16	0.5	14	0.5	11	0.5	11	
			-40°C to 125°C	0.5	136	0.5	96	0.5	76	0.5	29	0.5	21	0.5	19	0.5	15	0.5	14	
$t_{en}$ Enable time	DIR	A	-40°C to 85°C	0.5	238	0.5	178	0.5	151	0.5	38	0.5	30	0.5	28	0.5	22	0.5	24	ns
			-40°C to 125°C	0.5	263	0.5	186	0.5	157	0.5	44	0.5	36	0.5	33	0.5	26	0.5	27	
	DIR	B	-40°C to 85°C	0.5	104	0.5	63	0.5	49	0.5	33	0.5	29	0.5	28	0.5	26	0.5	26	
			-40°C to 125°C	0.5	109	0.5	68	0.5	54	0.5	38	0.5	35	0.5	34	0.5	32	0.5	32	

表 5-6. Switching Characteristics,  $V_{CCA} = 1.8V$

PARAMETER	FROM	TO	TEST CONDITIONS	B-PORT SUPPLY VOLTAGE ( $V_{CCB}$ )												UNIT				
				0.7 ± 0.05 V		0.8 ± 0.04 V		0.9 ± 0.045 V		1.2 ± 0.1V		1.5 ± 0.1V		1.8 ± 0.15 V			2.5 ± 0.2V		3.3 ± 0.3V	
				MIN	MAX	MIN	MAX	MIN	MAX	MIN	MAX	MIN	MAX	MIN	MAX		MIN	MAX	MIN	MAX
$t_{pd}$ Propagation delay	A	B	-40°C to 85°C	0.5	81	0.5	41	0.5	24	0.5	10	0.5	7	0.5	6	0.5	5	0.5	4	ns
			-40°C to 125°C	0.5	81	0.5	41	0.5	24	0.5	10	0.5	8	0.5	7	0.5	5	0.5	5	
	B	A	-40°C to 85°C	0.5	53	0.5	26	0.5	16	0.5	8	0.5	7	0.5	6	0.5	5	0.5	4	
			-40°C to 125°C	0.5	53	0.5	26	0.5	16	0.5	9	0.5	7	0.5	7	0.5	5	0.5	4	
$t_{dis}$ Disable time	DIR	A	-40°C to 85°C	0.5	13	0.5	13	0.5	13	0.5	13	0.5	13	0.5	13	0.5	13	0.5	13	ns
			-40°C to 125°C	0.5	18	0.5	18	0.5	18	0.5	18	0.5	18	0.5	18	0.5	18	0.5	18	
	DIR	B	-40°C to 85°C	0.5	136	0.5	96	0.5	72	0.5	22	0.5	15	0.5	14	0.5	11	0.5	11	
			-40°C to 125°C	0.5	136	0.5	96	0.5	75	0.5	28	0.5	20	0.5	18	0.5	14	0.5	13	
$t_{en}$ Enable time	DIR	A	-40°C to 85°C	0.5	241	0.5	176	0.5	148	0.5	35	0.5	28	0.5	26	0.5	21	0.5	24	ns
			-40°C to 125°C	0.5	266	0.5	184	0.5	155	0.5	42	0.5	33	0.5	32	0.5	24	0.5	26	
	DIR	B	-40°C to 85°C	0.5	101	0.5	61	0.5	44	0.5	30	0.5	27	0.5	26	0.5	25	0.5	24	
			-40°C to 125°C	0.5	105	0.5	65	0.5	48	0.5	34	0.5	32	0.5	31	0.5	29	0.5	29	

表 5-7. Switching Characteristics,  $V_{CCA} = 2.5V$ 

PARAMETER	FROM	TO	TEST CONDITIONS	B–PORT SUPPLY VOLTAGE ( $V_{CCB}$ )												UNIT				
				0.7 ± 0.05 V		0.8 ± 0.04 V		0.9 ± 0.045 V		1.2 ± 0.1V		1.5 ± 0.1V		1.8 ± 0.15 V			2.5 ± 0.2V		3.3 ± 0.3V	
				MIN	MAX	MIN	MAX	MIN	MAX	MIN	MAX	MIN	MAX	MIN	MAX		MIN	MAX	MIN	MAX
$t_{pd}$ Propagation delay	A	B	–40°C to 85°C	0.5	80	0.5	40	0.5	22	0.5	7	0.5	5	0.5	5	0.5	4	0.5	4	ns
			–40°C to 125°C	0.5	80	0.5	40	0.5	22	0.5	8	0.5	6	0.5	5	0.5	5	0.5	4	
	B	A	–40°C to 85°C	0.5	66	0.5	27	0.5	15	0.5	7	0.5	5	0.5	5	0.5	4	0.5	3	
			–40°C to 125°C	0.5	66	0.5	27	0.5	15	0.5	7	0.5	6	0.5	5	0.5	5	0.5	4	
$t_{dis}$ Disable time	DIR	A	–40°C to 85°C	0.5	10	0.5	10	0.5	10	0.5	10	0.5	10	0.5	10	0.5	10	0.5	10	ns
			–40°C to 125°C	0.5	13	0.5	13	0.5	13	0.5	13	0.5	13	0.5	13	0.5	13	0.5	13	
	DIR	B	–40°C to 85°C	0.5	136	0.5	95	0.5	71	0.5	21	0.5	14	0.5	13	0.5	10	0.5	10	
			–40°C to 125°C	0.5	136	0.5	95	0.5	75	0.5	27	0.5	20	0.5	17	0.5	13	0.5	12	
$t_{en}$ Enable time	DIR	A	–40°C to 85°C	0.5	254	0.5	176	0.5	147	0.5	33	0.5	25	0.5	24	0.5	19	0.5	22	ns
			–40°C to 125°C	0.5	278	0.5	185	0.5	153	0.5	39	0.5	31	0.5	29	0.5	23	0.5	25	
	DIR	B	–40°C to 85°C	0.5	99	0.5	55	0.5	41	0.5	22	0.5	24	0.5	20	0.5	23	0.5	19	
			–40°C to 125°C	0.5	98	0.5	58	0.5	40	0.5	26	0.5	24	0.5	23	0.5	23	0.5	22	

表 5-8. Switching Characteristics,  $V_{CCA} = 3.3V$ 

PARAMETER	FROM	TO	TEST CONDITIONS	B–PORT SUPPLY VOLTAGE ( $V_{CCB}$ )												UNIT				
				0.7 ± 0.05 V		0.8 ± 0.04 V		0.9 ± 0.045 V		1.2 ± 0.1V		1.5 ± 0.1V		1.8 ± 0.15 V			2.5 ± 0.2V		3.3 ± 0.3V	
				MIN	MAX	MIN	MAX	MIN	MAX	MIN	MAX	MIN	MAX	MIN	MAX		MIN	MAX	MIN	MAX
$t_{pd}$ Propagation delay	A	B	–40°C to 85°C	0.5	79	0.5	39	0.5	22	0.5	7	0.5	4	0.5	4	0.5	3	0.5	3	ns
			–40°C to 125°C	0.5	79	0.5	39	0.5	22	0.5	7	0.5	5	0.5	4	0.5	4	0.5	4	
	B	A	–40°C to 85°C	0.5	144	0.5	36	0.5	18	0.5	7	0.5	5	0.5	4	0.5	4	0.5	3	
			–40°C to 125°C	0.5	144	0.5	36	0.5	18	0.5	8	0.5	6	0.5	5	0.5	4	0.5	4	
$t_{dis}$ Disable time	DIR	A	–40°C to 85°C	0.5	9	0.5	9	0.5	9	0.5	9	0.5	9	0.5	9	0.5	9	0.5	9	ns
			–40°C to 125°C	0.5	12	0.5	12	0.5	12	0.5	12	0.5	12	0.5	12	0.5	12	0.5	12	
	DIR	B	–40°C to 85°C	0.5	136	0.5	95	0.5	71	0.5	21	0.5	14	0.5	12	0.5	10	0.5	10	
			–40°C to 125°C	0.5	136	0.5	95	0.5	75	0.5	27	0.5	19	0.5	17	0.5	13	0.5	12	
$t_{en}$ Enable time	DIR	A	–40°C to 85°C	0.5	331	0.5	185	0.5	149	0.5	33	0.5	25	0.5	23	0.5	19	0.5	22	ns
			–40°C to 125°C	0.5	356	0.5	93	0.5	156	0.5	40	0.5	31	0.5	29	0.5	22	0.5	24	
	DIR	B	–40°C to 85°C	0.5	98	0.5	58	0.5	41	0.5	26	0.5	23	0.5	23	0.5	22	0.5	22	
			–40°C to 125°C	0.5	99	0.5	59	0.5	42	0.5	27	0.5	25	0.5	24	0.5	24	0.5	24	

### 5.7 Operating Characteristics: $T_A = 25^\circ\text{C}$

PARAMETER		TEST CONDITIONS	$V_{CCA}$	$V_{CCB}$	MIN	TYP	MAX	UNIT
$C_{pdA}$	Power Dissipation Capacitance per transceiver (A to B)	$C_L = 0, R_L = \text{Open } f = 1 \text{ MHz}, t_r = t_f = 1 \text{ ns}$	0.7V	0.7V		1.3		pF
			0.8V	0.8V		1.3		
			0.9V	0.9V		1.3		
			1.2V	1.2V		1.3		
			1.5V	1.5V		1.3		
			1.8V	1.8V		1.4		
			2.5V	2.5V		1.7		
				3.3V	3.3V		2.1	
	Power Dissipation Capacitance per transceiver (B to A)	$C_L = 0, R_L = \text{Open } f = 1 \text{ MHz}, t_r = t_f = 1 \text{ ns}$	0.7V	0.7V		9.2		pF
			0.8V	0.8V		9.4		
			0.9V	0.9V		9.4		
			1.2V	1.2V		9.8		
			1.5V	1.5V		10.1		
			1.8V	1.8V		11.0		
2.5V			2.5V		14.4			
			3.3V	3.3V		18.6		
$C_{pdB}$	Power Dissipation Capacitance per transceiver (A to B)	$C_L = 0, R_L = \text{Open } f = 1 \text{ MHz}, t_r = t_f = 1 \text{ ns}$	0.7V	0.7V		9.2		pF
			0.8V	0.8V		9.3		
			0.9V	0.9V		9.4		
			1.2V	1.2V		9.7		
			1.5V	1.5V		10.1		
			1.8V	1.8V		11.0		
			2.5V	2.5V		14.4		
				3.3V	3.3V		18.3	
	Power Dissipation Capacitance per transceiver (B to A)	$C_L = 0, R_L = \text{Open } f = 1 \text{ MHz}, t_r = t_f = 1 \text{ ns}$	0.7V	0.7V		1.3		pF
			0.8V	0.8V		1.3		
			0.9V	0.9V		1.3		
			1.2V	1.2V		1.3		
			1.5V	1.5V		1.3		
			1.8V	1.8V		1.4		
2.5V			2.5V		1.7			
			3.3V	3.3V		2.1		

## 5.8 Typical Characteristics

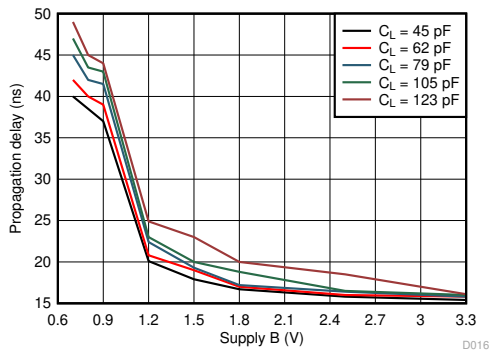

$T_A = 25^\circ\text{C}$   $V_{CCA} = 0.7\text{V}$

**5-1. Typical Propagation Delay of Low-to-High (A to B) vs Load Capacitance**

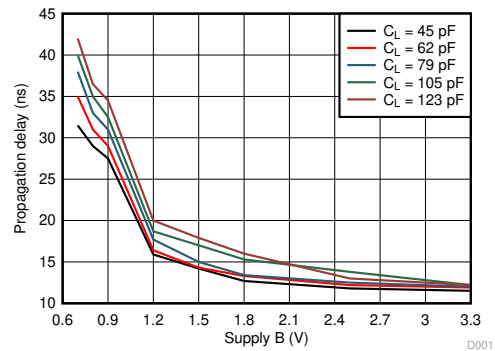

$T_A = 25^\circ\text{C}$   $V_{CCA} = 0.8\text{V}$

**5-2. Typical Propagation Delay of Low-to-High (A to B) vs Load Capacitance**

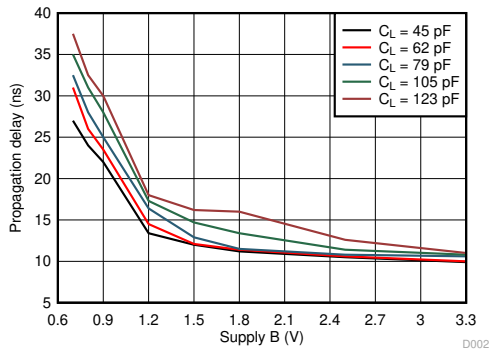

$T_A = 25^\circ\text{C}$   $V_{CCA} = 0.9\text{V}$

**5-3. Typical Propagation Delay of Low-to-High (A to B) vs Load Capacitance**

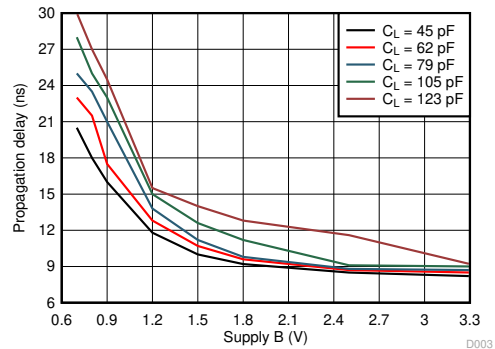

$T_A = 25^\circ\text{C}$   $V_{CCA} = 1.2\text{V}$

**5-4. Typical Propagation Delay of Low-to-High (A to B) vs Load Capacitance**

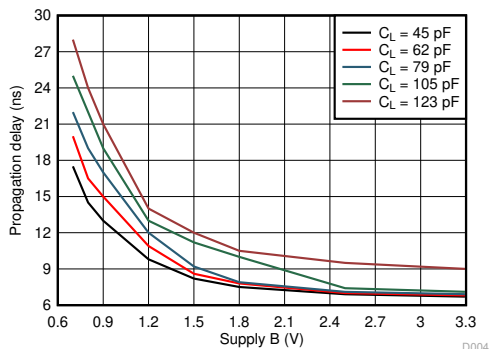

$T_A = 25^\circ\text{C}$   $V_{CCA} = 1.5\text{V}$

**5-5. Typical Propagation Delay of Low-to-High (A to B) vs Load Capacitance**

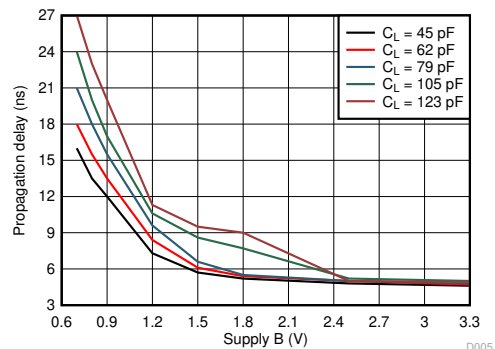

$T_A = 25^\circ\text{C}$   $V_{CCA} = 1.8\text{V}$

**5-6. Typical Propagation Delay of Low-to-High (A to B) vs Load Capacitance**

### 5.8 Typical Characteristics (continued)

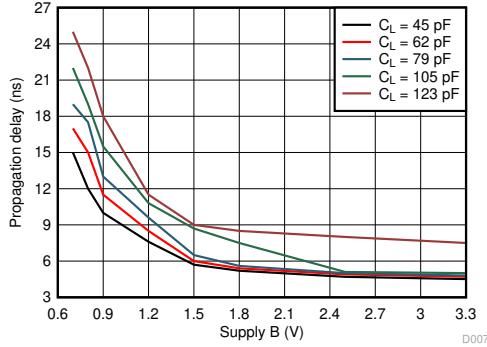

$T_A = 25^\circ\text{C}$   $V_{CCA} = 3.3\text{V}$

**5-7. Typical Propagation Delay of Low-to-High (A to B) vs Load Capacitance**

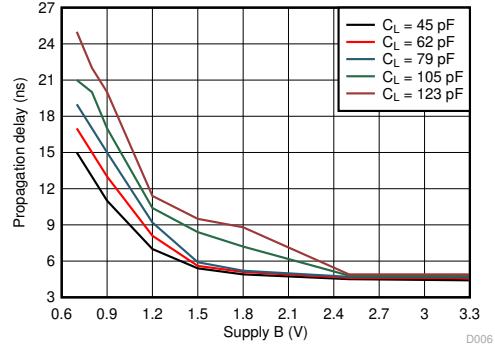

$T_A = 25^\circ\text{C}$   $V_{CCA} = 2.5\text{V}$

**5-8. Typical Propagation Delay of Low-to-High (A to B) vs Load Capacitance**

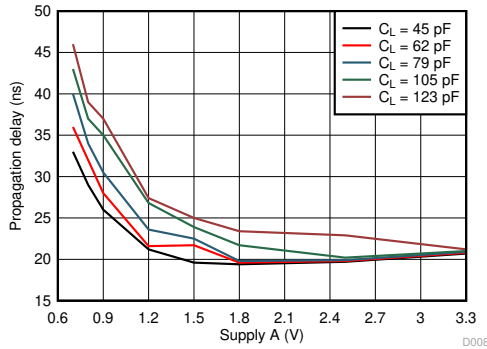

$T_A = 25^\circ\text{C}$   $V_{CCA} = 0.7\text{V}$

**5-9. Typical Propagation Delay of Low-to-High (B to A) vs Load Capacitance**

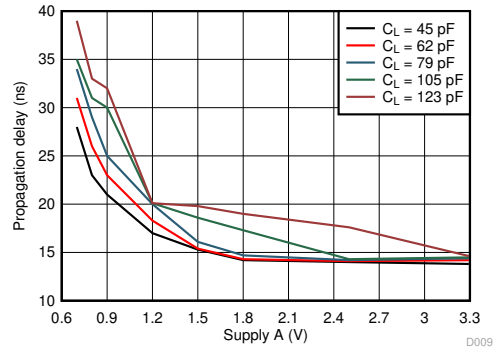

$T_A = 25^\circ\text{C}$   $V_{CCA} = 0.8\text{V}$

**5-10. Typical Propagation Delay of Low-to-High (B to A) vs Load Capacitance**

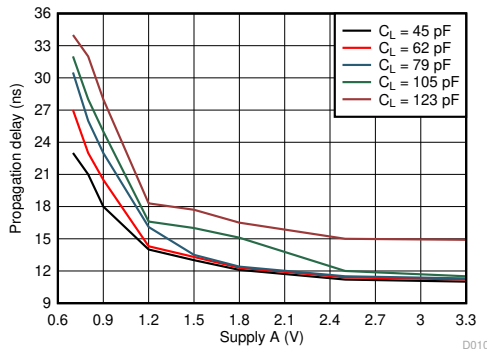

$T_A = 25^\circ\text{C}$   $V_{CCA} = 0.9\text{V}$

**5-11. Typical Propagation Delay of Low-to-High (B to A) vs Load Capacitance**

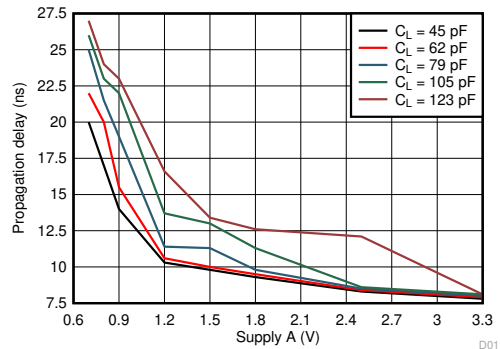

$T_A = 25^\circ\text{C}$   $V_{CCA} = 1.2\text{V}$

**5-12. Typical Propagation Delay of Low-to-High (B to A) vs Load Capacitance**

### 5.8 Typical Characteristics (continued)

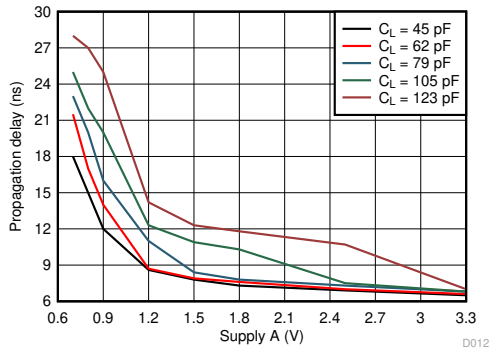

$T_A = 25^\circ\text{C}$   $V_{CCA} = 1.5\text{V}$

**5-13. Typical Propagation Delay of Low-to-High (B to A) vs Load Capacitance**

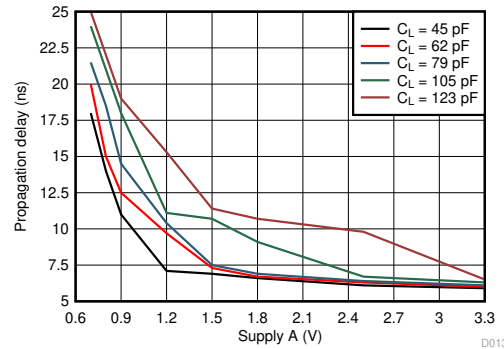

$T_A = 25^\circ\text{C}$   $V_{CCA} = 1.8\text{V}$

**5-14. Typical Propagation Delay of Low-to-High (B to A) vs Load Capacitance**

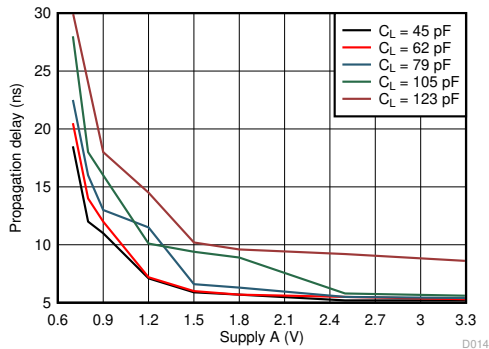

$T_A = 25^\circ\text{C}$   $V_{CCA} = 2.5\text{V}$

**5-15. Typical Propagation Delay of Low-to-High (B to A) vs Load Capacitance**

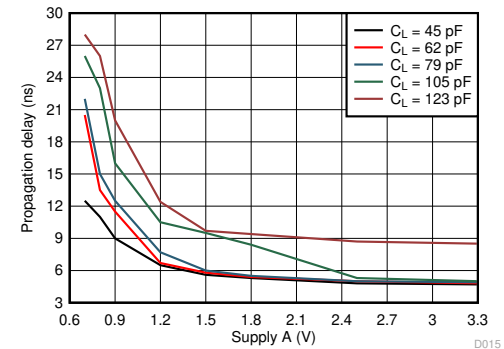

$T_A = 25^\circ\text{C}$   $V_{CCA} = 3.3\text{V}$

**5-16. Typical Propagation Delay of Low-to-High (B to A) vs Load Capacitance**

## 6 Parameter Measurement Information

### 6.1 Load Circuit and Voltage Waveforms

Unless otherwise noted, all input pulses are supplied by generators having the following characteristics:

- $f = 1 \text{ MHz}$
- $Z_O = 50 \Omega$
- $dv/dt \leq 1 \text{ ns/V}$

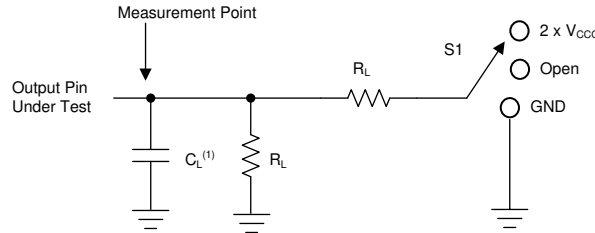

A.  $C_L$  includes probe and jig capacitance.

図 6-1. Load Circuit

表 6-1. Load Circuit Conditions

Parameter	$V_{CCO}$	$R_L$	$C_L$	$S_1$	$V_{TP}$
$\Delta t/\Delta v$ Input transition rise or fall rate	0.65 V – 3.6V	1M $\Omega$	15pF	Open	N/A
$t_{pd}$ Propagation (delay) time	1.1V – 3.6V	2k $\Omega$	15pF	Open	N/A
	0.65 V – 0.95 V	20k $\Omega$	15pF	Open	N/A
$t_{en}, t_{dis}$ Enable time, disable time	3V – 3.6V	2k $\Omega$	15pF	$2 \times V_{CCO}$	0.3V
	1.65 V – 2.7V	2k $\Omega$	15pF	$2 \times V_{CCO}$	0.15 V
	1.1V – 1.6V	2k $\Omega$	15pF	$2 \times V_{CCO}$	0.1V
	0.65 V – 0.95 V	20k $\Omega$	15pF	$2 \times V_{CCO}$	0.1V
$t_{en}, t_{dis}$ Enable time, disable time	3V – 3.6V	2k $\Omega$	15pF	GND	0.3V
	1.65 V – 2.7V	2k $\Omega$	15pF	GND	0.15 V
	1.1V – 1.6V	2k $\Omega$	15pF	GND	0.1V
	0.65 V – 0.95 V	20k $\Omega$	15pF	GND	0.1V

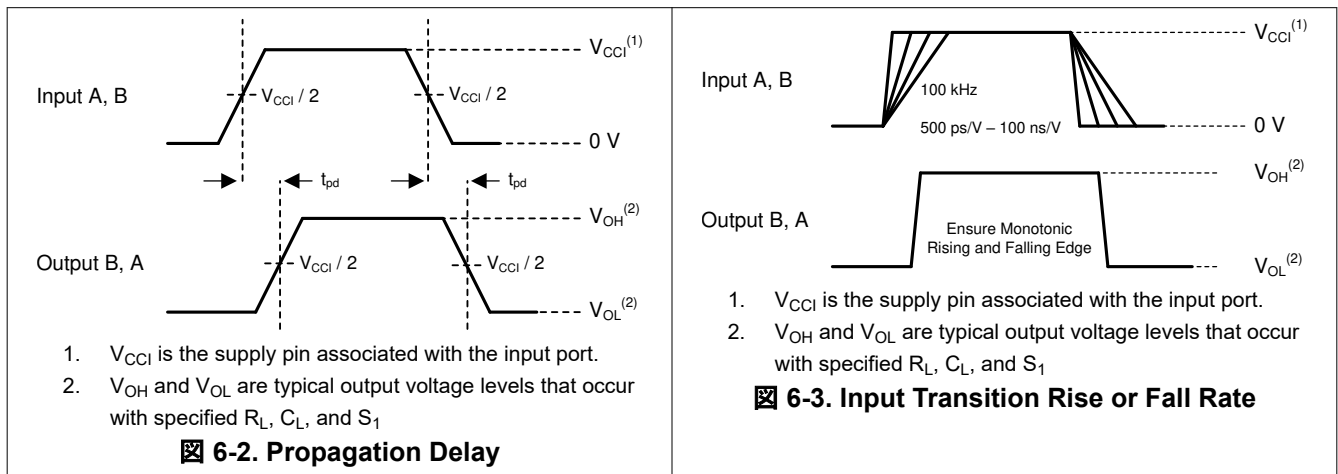

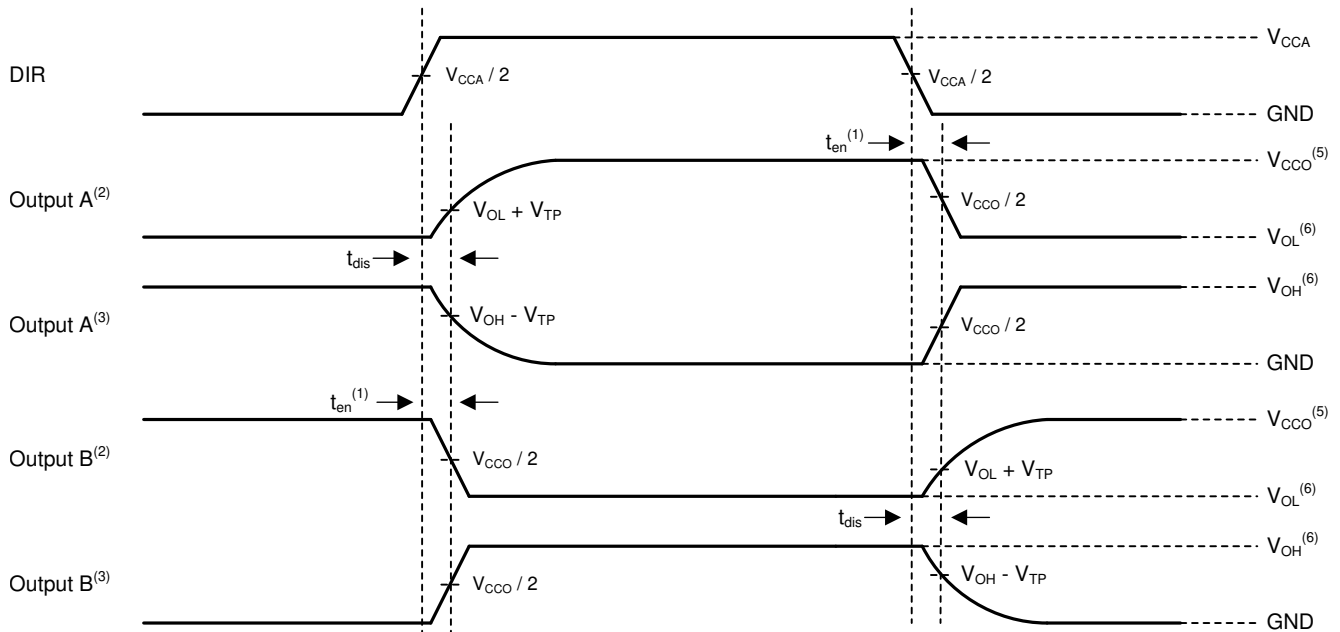

1. Illustrative purposes only. Enable Time is a calculation as described in the data sheet.
2. Output waveform on the condition that input is driven to a valid Logic Low.
3. Output waveform on the condition that input is driven to a valid Logic High.
4.  $V_{CCI}$  is the supply pin associated with the input port
5.  $V_{CCO}$  is the supply pin associated with the output port.
6.  $V_{OH}$  and  $V_{OL}$  are typical output voltage levels that occur with specified  $R_L$ ,  $C_L$ , and  $S_1$

#### 6-4. Disable and Enable Time



## 7 Detailed Description

### 7.1 Overview

The SN74AXC1T45 is single-bit, dual-supply, noninverting voltage level translation. Pin A and the direction control pin are support by  $V_{CCA}$  and pin B is support by  $V_{CCB}$ . The A port can accept I/O voltages ranging from 0.65 V to 3.6V, and the B port can accept I/O voltages from 0.65 V to 3.6V. A high logic on the DIR pin allows data transmission from A to B and a logic low on the DIR pin allows data transmission from B to A.

### 7.2 Functional Block Diagram

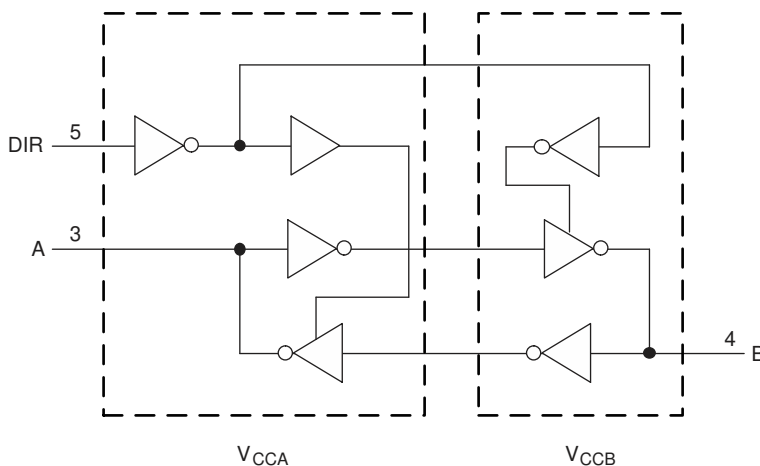

### 7.3 Feature Description

#### 7.3.1 Fully Configurable Dual-Rail Design Allows Each Port to Operate Over the Full 0.65-V to 3.6-V Power-Supply Range

Both the  $V_{CCA}$  and  $V_{CCB}$  pins can be supplied at any voltage from 0.65 V to 3.6V, making the device suitable for translating between any of the voltage nodes (0.7V, 0.8V, 0.9V, 1.2V, 1.8V, 2.5V and 3.3V).

#### 7.3.2 I/Os with Integrated Static Pull-Down Resistors

To help avoid floating inputs on the I/Os, this device has 288-k $\Omega$  typical integrated weak pull-downs on all data I/Os. This feature allows all inputs to be left floating without the concern for unstable outputs or increased current consumption. This also helps to reduce external component count for applications where not all channels are used or need to be fixed low. If an external pull-up is required, it should be no larger than 30-k $\Omega$  to avoid contention with the 288-k $\Omega$  internal pull-down.

#### 7.3.3 Support High-Speed Translation

The SN74AXC1T45 device can support high data-rate applications. The translated signal data rate can be up to 500Mbps when signal is translated from 1.8V to 3.3V.

#### 7.3.4 $I_{off}$ Supports Partial-Power-Down Mode Operation

The  $I_{off}$  circuit prevents backflow current by disabling the I/O output circuits when the device is in partial-power-down mode.

## 7.4 Device Functional Modes

表 7-1 lists the device functions for the DIR input.

**表 7-1. Function Table**

INPUT <sup>(1)</sup> DIR	OPERATION
L	B data to A bus
H	A data to B bus

(1) Input circuits of the data I/Os always are active.

## 8 Application and Implementation

### 注

Information in the following applications sections is not part of the TI component specification, and TI does not warrant its accuracy or completeness. TI's customers are responsible for determining suitability of components for their purposes. Customers should validate and test their design implementation to confirm system functionality.

### 8.1 Application Information

The SN74AXC1T45 device can be used in level-translation applications for interfacing devices or systems with one another when they are operating at different interface voltages. The maximum data rate can be up to 500Mbps when the device translate signal is from 1.8V to 3.3V.

#### 8.1.1 Enable Times

Calculate the enable times for the SN74AXC1T45 using the following formulas:

$$t_{A\_en} (\text{DIR to A}) = t_{dis} (\text{DIR to B}) + t_{pd} (\text{B to A}) \quad (1)$$

$$t_{B\_en} (\text{DIR to B}) = t_{dis} (\text{DIR to A}) + t_{pd} (\text{A to B}) \quad (2)$$

In a bidirectional application, these enable times provide the maximum delay time from the time the DIR bit is switched until an output is expected. For example, if the SN74AXC1T45 initially is transmitting from A to B, then the DIR bit is switched; the B port of the device must be disabled ( $t_{dis}$ ) before presenting it with an input. After the B port has been disabled, an input signal applied to it appears on the corresponding A port after the specified propagation delay ( $t_{pd}$ ). To avoid bus contention care should be taken to not apply an input signal prior to the output port being disabled ( $t_{dis\ max}$ ).

### 8.2 Typical Applications

#### 8.2.1 Unidirectional Logic Level-Shifting Application

☒ 8-1 shows an example of the SN74AXC1T45 being used in a unidirectional logic level-shifting application.

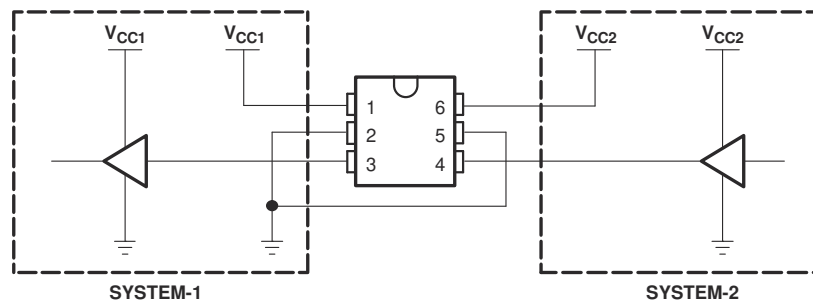

☒ 8-1. Unidirectional Logic Level-Shifting Application

表 8-1. Unidirectional Level Shifting Function

PIN	NAME	FUNCTION	DESCRIPTION
1	V <sub>CCA</sub>	V <sub>CC1</sub>	SYSTEM-1 supply voltage (0.65 V to 3.6V)
2	GND	GND	Device GND
3	A	OUT	Output level depends on V <sub>CC1</sub> voltage.
4	B	IN	Input threshold value depends on V <sub>CC2</sub> voltage.
5	DIR	DIR	GND (low level) determines B-port to A-port direction.
6	V <sub>CCB</sub>	V <sub>CC2</sub>	SYSTEM-2 supply voltage (0.65 V to 3.6V)

### 8.2.1.1 Design Requirements

For this design example, use the parameters listed in 表 8-2.

表 8-2. Design Parameters

DESIGN PARAMETERS	EXAMPLE VALUES
Input voltage range	0.65 V to 3.6V
Output voltage range	0.65 V to 3.6V

### 8.2.1.2 Detailed Design Procedure

To begin the design process, determine the following:

- Input voltage range
  - Use the supply voltage of the device that is driving the SN74AXC1T45 device to determine the input voltage range. For a valid logic-high, the value must exceed the high-level input voltage ( $V_{IH}$ ) of the input port. For a valid logic low the value must be less than the low-level input voltage ( $V_{IL}$ ) of the input port.
- Output voltage range
  - Use the supply voltage of the device that the SN74AXC1T45 device is driving to determine the output voltage range.

### 8.2.1.3 Application Curve



図 8-2. Up Translation at 2.5 MHz (0.7V to 3.3V)

## 8.2.2 Bidirectional Logic Level-Shifting Application

Figure 8-3 shows the SN74AXC1T45 being used in a bidirectional logic level-shifting application. Because the SN74AXC1T45 does not have an output-enable (OE) pin, the system designer should take precautions to avoid bus contention between SYSTEM-1 and SYSTEM-2 when changing directions.

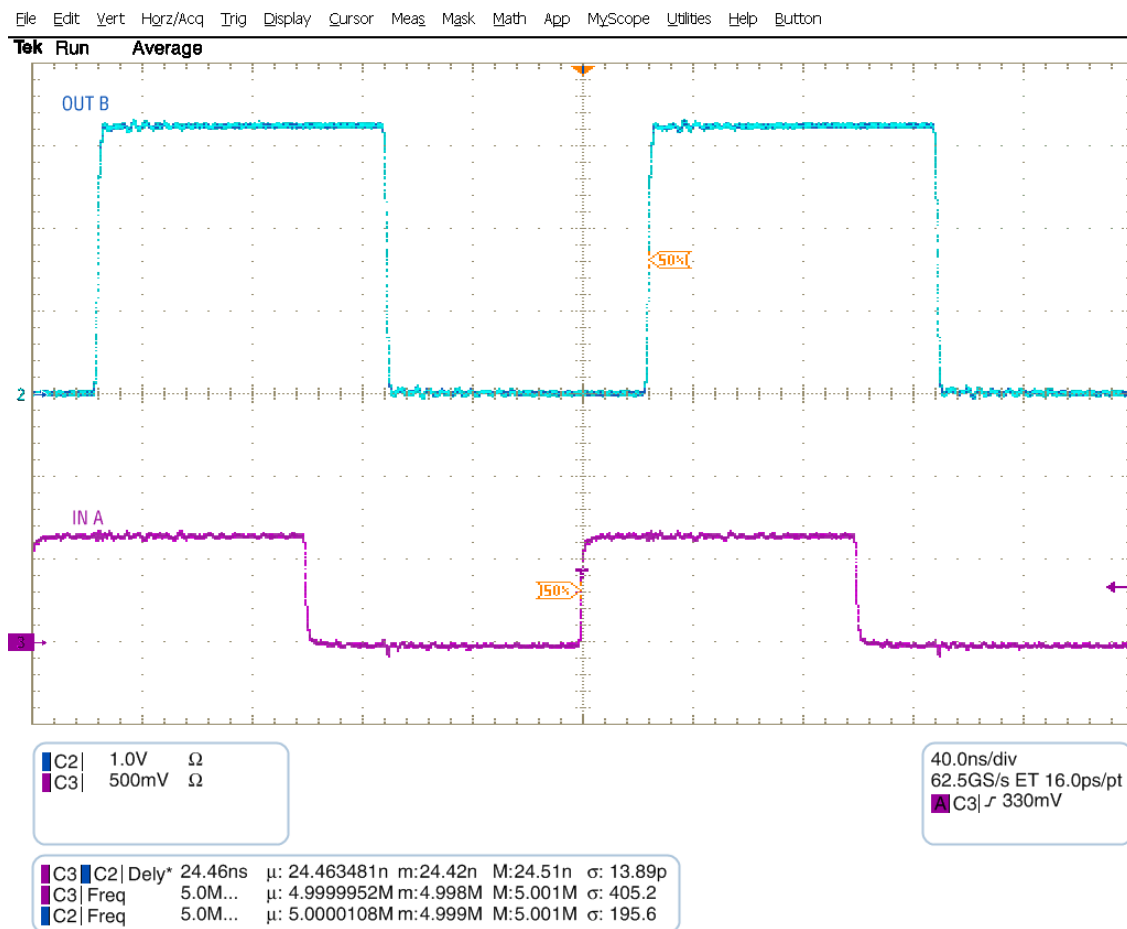
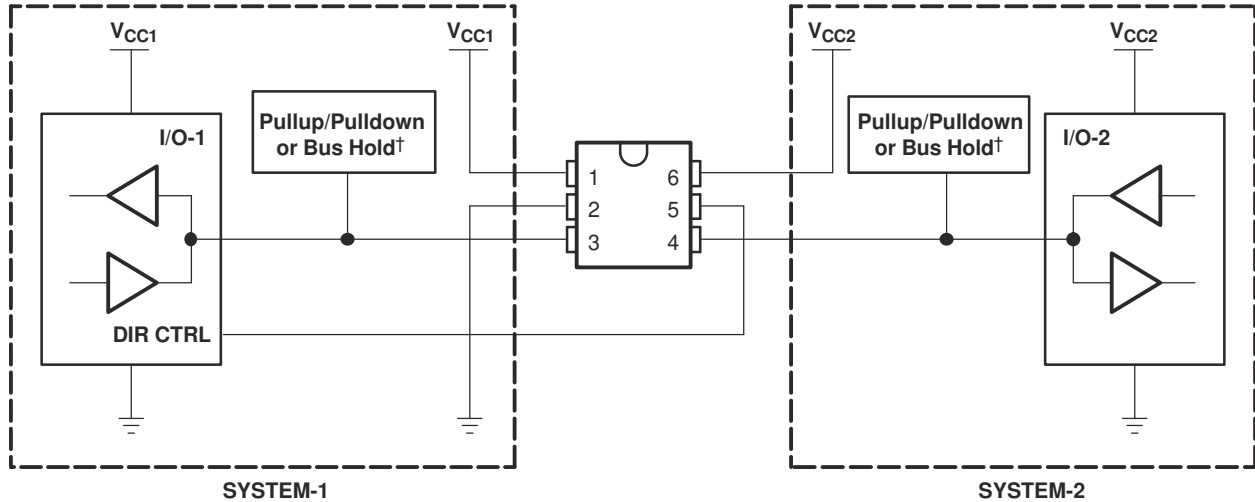

Figure 8-3. Bidirectional Logic Level-Shifting Application

Table 8-3 lists the data transmission from SYSTEM-1 to SYSTEM-2 and then from SYSTEM-2 to SYSTEM-1.

Table 8-3. Data Transmission: SYSTEM-1 and SYSTEM-2

STATE	DIR CTRL	I/O-1	I/O-2	DESCRIPTION
1	H	Out	In	SYSTEM-1 data to SYSTEM-2.
2	H	Hi-Z	Hi-Z	SYSTEM-2 is getting ready to send data to SYSTEM-1. I/O-1 and I/O-2 are disabled. The bus-line state depends on pullup or pulldown resistors. <sup>(1)</sup>
3	L	Hi-Z	Hi-Z	DIR bit is flipped. I/O-1 and I/O-2 still are disabled. The bus-line state depends on pullup or pulldown resistors. <sup>(1)</sup>
4	L	In	Out	SYSTEM-2 data to SYSTEM-1.

(1) SYSTEM-1 and SYSTEM-2 must use the same conditions, essentially, both pullup or both pulldown.

### 8.2.2.1 Design Requirements

Refer to [Design Requirements](#).

### 8.2.2.2 Detailed Design Procedure

Refer to [Detailed Design Procedure](#).

### 8.2.2.3 Application Curve



図 8-4. Up Translation at 2.5 MHz (0.7V to 3.3V)

## 8.3 Power Supply Recommendations

The SN74AXC1T45 device uses two separate configurable power-supply rails,  $V_{CCA}$  and  $V_{CCB}$ . The  $V_{CCA}$  power-supply rail accepts any supply voltage from 0.65 V to 3.6 V and the  $V_{CCB}$  power-supply rail accepts any supply voltage from 0.65 V to 3.6 V. The A port and B port are designed to track the  $V_{CCA}$  and  $V_{CCB}$  supplies respectively allowing for low-voltage, bidirectional translation between any of the 0.7V, 0.8V, 0.9V, 1.2V, 1.5V, 1.8V, 2.5V, and 3.3V voltage nodes.

### 8.3.1 Power-Up Considerations

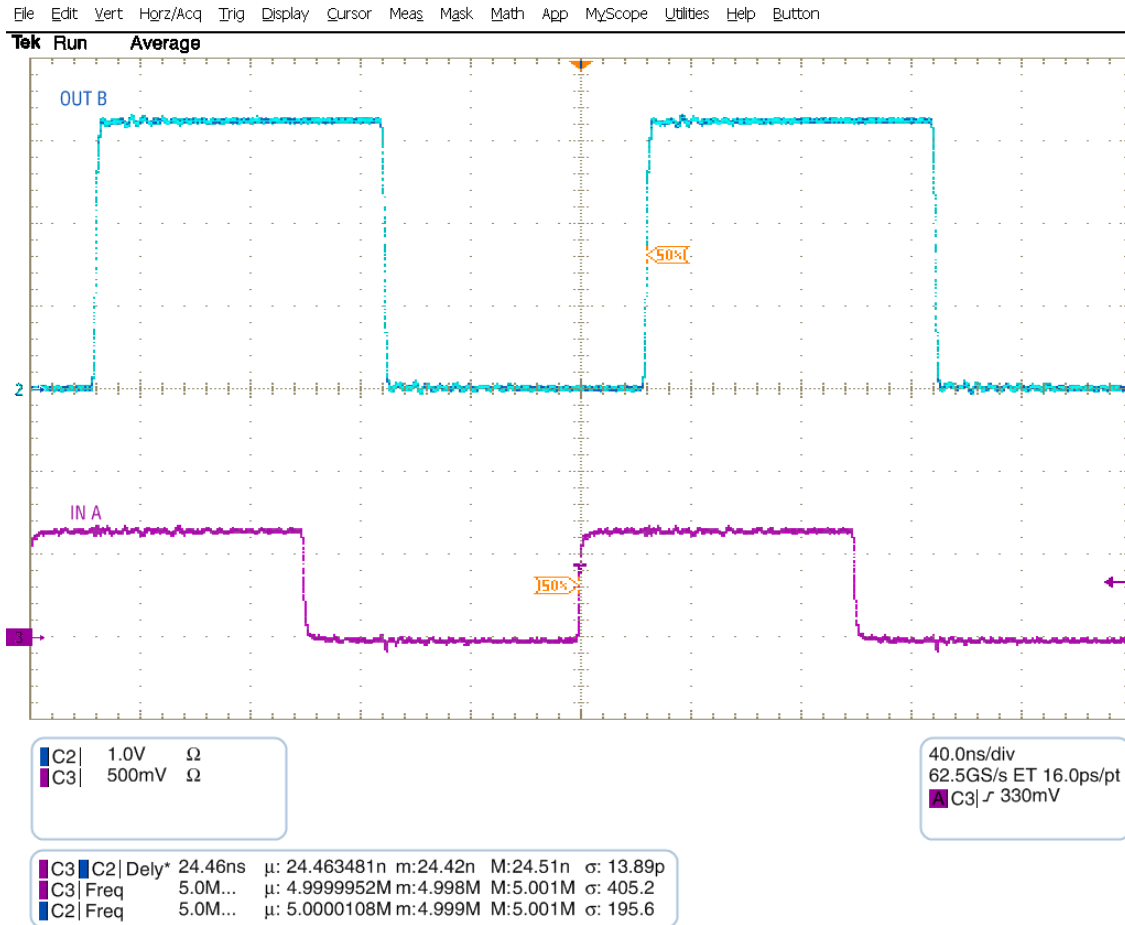
A proper power-up sequence must be followed to avoid excessive supply current, bus contention, oscillations, or other anomalies. To guard against such power-up problems, take the following precautions:

1. Connect the ground before any supply voltage is applied.
2. Power up the  $V_{CCA}$  and  $V_{CCB}$  supplies. The  $V_{CCA}$  and  $V_{CCB}$  supplies can be ramped in any order.

## 8.4 Layout

### 8.4.1 Layout Guidelines

To ensure reliability of the device, following common printed-circuit board layout guidelines is recommended:

- Bypass capacitors should be used on power supplies.
- Short trace lengths should be used to avoid excessive loading.

- Placing pads on the signal paths for loading capacitors or pullup resistors to help adjust rise and fall times of signals depending on the system requirements.

### 8.4.2 Layout Example

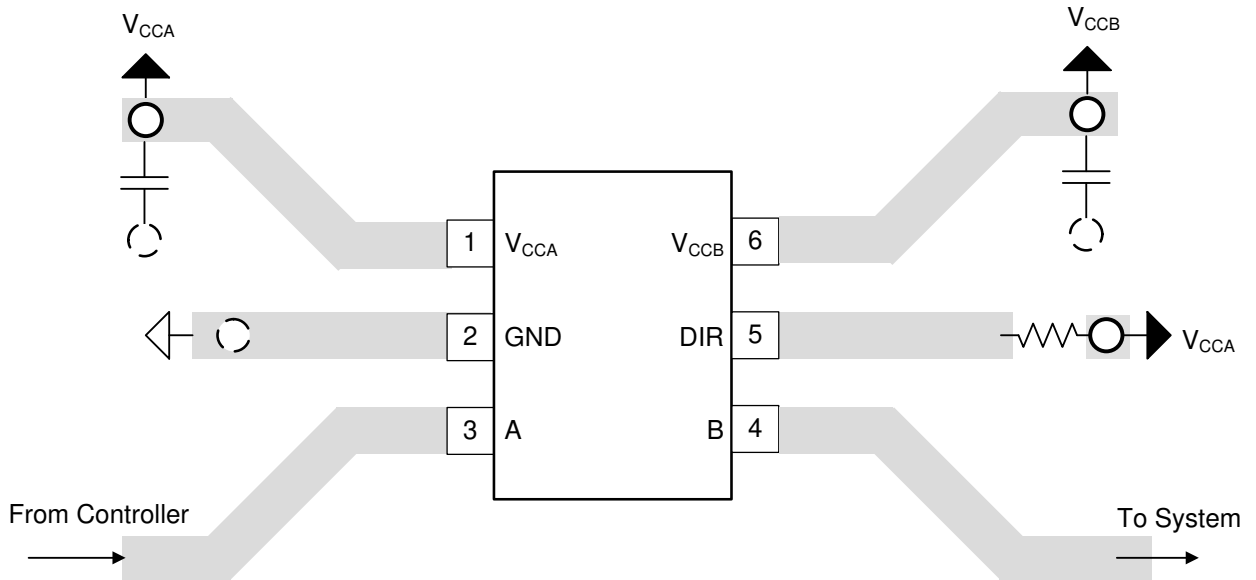
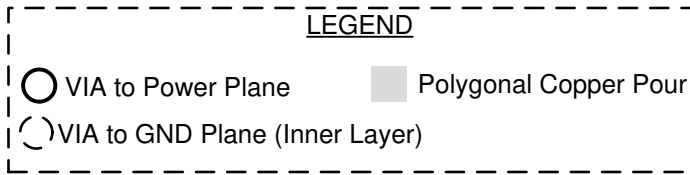

☒ 8-5. PCB Layout Example

## 9 Device and Documentation Support

### 9.1 Documentation Support

#### 9.1.1 Related Documentation

For related documentation see the following:

- Texas Instruments, [Evaluate SN74AXC1T45DRL Using a Generic EVM application report](#)
- Texas Instruments, [Implications of Slow or Floating CMOS Inputs application report](#)
- Texas Instruments, [Power Sequencing for the AXC Family of Devices application report](#)

### 9.2 ドキュメントの更新通知を受け取る方法

ドキュメントの更新についての通知を受け取るには、[www.tij.co.jp](http://www.tij.co.jp) のデバイス製品フォルダを開いてください。[通知] をクリックして登録すると、変更されたすべての製品情報に関するダイジェストを毎週受け取ることができます。変更の詳細については、改訂されたドキュメントに含まれている改訂履歴をご覧ください。

### 9.3 サポート・リソース

テキサス・インスツルメンツ E2E™ サポート・フォーラムは、エンジニアが検証済みの回答と設計に関するヒントをエキスパートから迅速かつ直接得ることができる場所です。既存の回答を検索したり、独自の質問をしたりすることで、設計に必要な支援を迅速に得ることができます。

リンクされているコンテンツは、各寄稿者により「現状のまま」提供されるものです。これらはテキサス・インスツルメンツの仕様を構成するものではなく、必ずしもテキサス・インスツルメンツの見解を反映したものではありません。テキサス・インスツルメンツの[使用条件](#)を参照してください。

### 9.4 Trademarks

テキサス・インスツルメンツ E2E™ is a trademark of Texas Instruments.

すべての商標は、それぞれの所有者に帰属します。

### 9.5 静電気放電に関する注意事項



この IC は、ESD によって破損する可能性があります。テキサス・インスツルメンツは、IC を取り扱う際には常に適切な注意を払うことを推奨します。正しい取り扱いおよび設置手順に従わない場合、デバイスを破損するおそれがあります。

ESD による破損は、わずかな性能低下からデバイスの完全な故障まで多岐にわたります。精密な IC の場合、パラメータがわずかに変化するだけで公表されている仕様から外れる可能性があるため、破損が発生しやすくなっています。

### 9.6 用語集

[テキサス・インスツルメンツ用語集](#) この用語集には、用語や略語の一覧および定義が記載されています。

## 10 Revision History

資料番号末尾の英字は改訂を表しています。その改訂履歴は英語版に準じています。

### Changes from Revision D (October 2021) to Revision E (December 2023) Page

- Added the *I/Os with Integrated Static Pull-Down Resistors* section..... 17

### Changes from Revision C (September 2020) to Revision D (October 2021) Page

- Updated the *Pin Configuration and Functions* section to include *DRL* and *DEA* packages..... 3

### Changes from Revision B (June 2018) to Revision C (September 2020) Page

- 文書全体にわたって表、図、相互参照の採番方法を更新..... 1



• すべての表を最新の 3D 表形式に更新.....	1
• Updated I <sub>CCA</sub> , I <sub>CCB</sub> , and I <sub>CCA</sub> + I <sub>CCB</sub> to reflect updated performance of device.....	6

---

<b>Changes from Revision A (April 2018) to Revision B (June 2018)</b>	<b>Page</b>
---	-------------

---

• アクティブなパッケージ オプションとして DEA と DTQ を追加.....	1
• 製品ステータスを量産混合から量産データに変更.....	1

---

<b>Changes from Revision * (December 2017) to Revision A (April 2018)</b>	<b>Page</b>
---	-------------

---

• Added pinout drawing for DEA package .....	3
• Added pinout drawing for DTQ package .....	3

---

## 11 Mechanical, Packaging, and Orderable Information

The following pages include mechanical, packaging, and orderable information. This information is the most current data available for the designated devices. This data is subject to change without notice and revision of this document. For browser-based versions of this data sheet, refer to the left-hand navigation.

## 重要なお知らせと免責事項

テキサス・インスツルメンツは、技術データと信頼性データ(データシートを含みます)、設計リソース(リファレンス デザインを含みます)、アプリケーションや設計に関する各種アドバイス、Web ツール、安全性情報、その他のリソースを、欠陥が存在する可能性のある「現状のまま」提供しており、商品性および特定目的に対する適合性の黙示保証、第三者の知的財産権の非侵害保証を含むいかなる保証も、明示的または黙示的にかかわらず拒否します。

これらのリソースは、テキサス・インスツルメンツ製品を使用する設計の経験を積んだ開発者への提供を意図したものです。(1) お客様のアプリケーションに適したテキサス・インスツルメンツ製品の選定、(2) お客様のアプリケーションの設計、検証、試験、(3) お客様のアプリケーションに該当する各種規格や、その他のあらゆる安全性、セキュリティ、規制、または他の要件への確実な適合に関する責任を、お客様のみが単独で負うものとします。

上記の各種リソースは、予告なく変更される可能性があります。これらのリソースは、リソースで説明されているテキサス・インスツルメンツ製品を使用するアプリケーションの開発の目的でのみ、テキサス・インスツルメンツはその使用をお客様に許諾します。これらのリソースに関して、他の目的で複製することや掲載することは禁止されています。テキサス・インスツルメンツや第三者の知的財産権のライセンスが付与されている訳ではありません。お客様は、これらのリソースを自身で使用した結果発生するあらゆる申し立て、損害、費用、損失、責任について、テキサス・インスツルメンツおよびその代理人を完全に補償するものとし、テキサス・インスツルメンツは一切の責任を拒否します。

テキサス・インスツルメンツの製品は、[テキサス・インスツルメンツの販売条件](#)、または [ti.com](https://www.ti.com) やかかるテキサス・インスツルメンツ製品の関連資料などのいずれかを通じて提供する適用可能な条項の下で提供されています。テキサス・インスツルメンツがこれらのリソースを提供することは、適用されるテキサス・インスツルメンツの保証または他の保証の放棄の拡大や変更を意味するものではありません。

お客様がいかなる追加条項または代替条項を提案した場合でも、テキサス・インスツルメンツはそれらに異議を唱え、拒否します。

郵送先住所: Texas Instruments, Post Office Box 655303, Dallas, Texas 75265  
Copyright © 2024, Texas Instruments Incorporated

**PACKAGING INFORMATION**

Orderable Device	Status (1)	Package Type	Package Drawing	Pins	Package Qty	Eco Plan (2)	Lead finish/ Ball material (6)	MSL Peak Temp (3)	Op Temp (°C)	Device Marking (4/5)	Samples
SN74AXC1T45DBVR	ACTIVE	SOT-23	DBV	6	3000	RoHS & Green	NIPDAU   SN	Level-1-260C-UNLIM	-40 to 125	1GRL	<a href="#">Samples</a>
SN74AXC1T45DCKR	ACTIVE	SC70	DCK	6	3000	RoHS & Green	SN	Level-1-260C-UNLIM	-40 to 125	1A3	<a href="#">Samples</a>
SN74AXC1T45DEAR	ACTIVE	X2SON	DEA	6	5000	RoHS & Green	NIPDAU	Level-1-260C-UNLIM	-40 to 125	CR	<a href="#">Samples</a>
SN74AXC1T45DRLR	ACTIVE	SOT-5X3	DRL	6	4000	RoHS & Green	NIPDAU   NIPDAUAG	Level-1-260C-UNLIM	-40 to 125	1A1	<a href="#">Samples</a>
SN74AXC1T45DTQR	ACTIVE	X2SON	DTQ	6	3000	RoHS & Green	NIPDAU	Level-1-260C-UNLIM	-40 to 125	CW	<a href="#">Samples</a>

(1) The marketing status values are defined as follows:

**ACTIVE:** Product device recommended for new designs.

**LIFEBUY:** TI has announced that the device will be discontinued, and a lifetime-buy period is in effect.

**NRND:** Not recommended for new designs. Device is in production to support existing customers, but TI does not recommend using this part in a new design.

**PREVIEW:** Device has been announced but is not in production. Samples may or may not be available.

**OBsolete:** TI has discontinued the production of the device.

(2) **RoHS:** TI defines "RoHS" to mean semiconductor products that are compliant with the current EU RoHS requirements for all 10 RoHS substances, including the requirement that RoHS substance do not exceed 0.1% by weight in homogeneous materials. Where designed to be soldered at high temperatures, "RoHS" products are suitable for use in specified lead-free processes. TI may reference these types of products as "Pb-Free".

**RoHS Exempt:** TI defines "RoHS Exempt" to mean products that contain lead but are compliant with EU RoHS pursuant to a specific EU RoHS exemption.

**Green:** TI defines "Green" to mean the content of Chlorine (Cl) and Bromine (Br) based flame retardants meet JS709B low halogen requirements of <=1000ppm threshold. Antimony trioxide based flame retardants must also meet the <=1000ppm threshold requirement.

(3) MSL, Peak Temp. - The Moisture Sensitivity Level rating according to the JEDEC industry standard classifications, and peak solder temperature.

(4) There may be additional marking, which relates to the logo, the lot trace code information, or the environmental category on the device.

(5) Multiple Device Markings will be inside parentheses. Only one Device Marking contained in parentheses and separated by a "~" will appear on a device. If a line is indented then it is a continuation of the previous line and the two combined represent the entire Device Marking for that device.

(6) Lead finish/Ball material - Orderable Devices may have multiple material finish options. Finish options are separated by a vertical ruled line. Lead finish/Ball material values may wrap to two lines if the finish value exceeds the maximum column width.

**Important Information and Disclaimer:**The information provided on this page represents TI's knowledge and belief as of the date that it is provided. TI bases its knowledge and belief on information provided by third parties, and makes no representation or warranty as to the accuracy of such information. Efforts are underway to better integrate information from third parties. TI has taken and continues to take reasonable steps to provide representative and accurate information but may not have conducted destructive testing or chemical analysis on incoming materials and chemicals. TI and TI suppliers consider certain information to be proprietary, and thus CAS numbers and other limited information may not be available for release.

In no event shall TI's liability arising out of such information exceed the total purchase price of the TI part(s) at issue in this document sold by TI to Customer on an annual basis.

**OTHER QUALIFIED VERSIONS OF SN74AXC1T45 :**

- Automotive : [SN74AXC1T45-Q1](#)

NOTE: Qualified Version Definitions:

- Automotive - Q100 devices qualified for high-reliability automotive applications targeting zero defects

**TAPE AND REEL INFORMATION**

**QUADRANT ASSIGNMENTS FOR PIN 1 ORIENTATION IN TAPE**

\*All dimensions are nominal

Device	Package Type	Package Drawing	Pins	SPQ	Reel Diameter (mm)	Reel Width W1 (mm)	A0 (mm)	B0 (mm)	K0 (mm)	P1 (mm)	W (mm)	Pin1 Quadrant
SN74AXC1T45DBVR	SOT-23	DBV	6	3000	180.0	8.4	3.2	3.2	1.4	4.0	8.0	Q3
SN74AXC1T45DCKR	SC70	DCK	6	3000	180.0	8.4	2.3	2.5	1.2	4.0	8.0	Q3
SN74AXC1T45DEAR	X2SON	DEA	6	5000	180.0	9.5	1.13	1.13	0.5	4.0	8.0	Q3
SN74AXC1T45DRLR	SOT-5X3	DRL	6	4000	180.0	8.4	2.0	1.8	0.75	4.0	8.0	Q3
SN74AXC1T45DTQR	X2SON	DTQ	6	3000	180.0	9.5	0.94	1.13	0.5	2.0	8.0	Q2

**TAPE AND REEL BOX DIMENSIONS**

\*All dimensions are nominal

Device	Package Type	Package Drawing	Pins	SPQ	Length (mm)	Width (mm)	Height (mm)
SN74AXC1T45DBVR	SOT-23	DBV	6	3000	210.0	185.0	35.0
SN74AXC1T45DCKR	SC70	DCK	6	3000	210.0	185.0	35.0
SN74AXC1T45DEAR	X2SON	DEA	6	5000	189.0	185.0	36.0
SN74AXC1T45DRLR	SOT-5X3	DRL	6	4000	210.0	185.0	35.0
SN74AXC1T45DTQR	X2SON	DTQ	6	3000	189.0	185.0	36.0

# DRL0006A



# PACKAGE OUTLINE

## SOT - 0.6 mm max height

PLASTIC SMALL OUTLINE

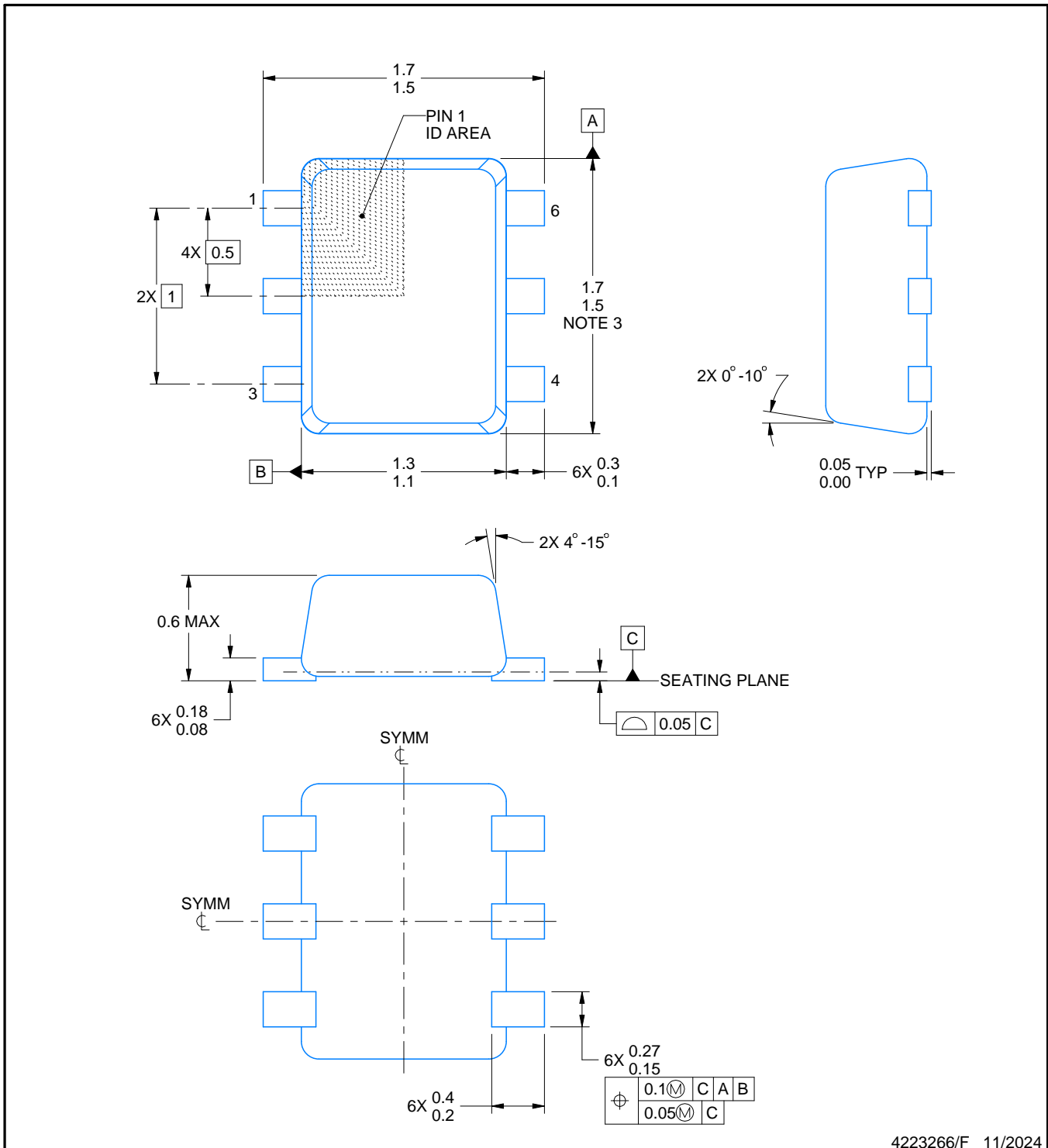

4223266/F 11/2024

### NOTES:

1. All linear dimensions are in millimeters. Any dimensions in parenthesis are for reference only. Dimensioning and tolerancing per ASME Y14.5M.
2. This drawing is subject to change without notice.
3. This dimension does not include mold flash, protrusions, or gate burrs. Mold flash, protrusions, or gate burrs shall not exceed 0.15 mm per side.
4. Reference JEDEC registration MO-293 Variation UAAD

# EXAMPLE BOARD LAYOUT

DRL0006A

SOT - 0.6 mm max height

PLASTIC SMALL OUTLINE

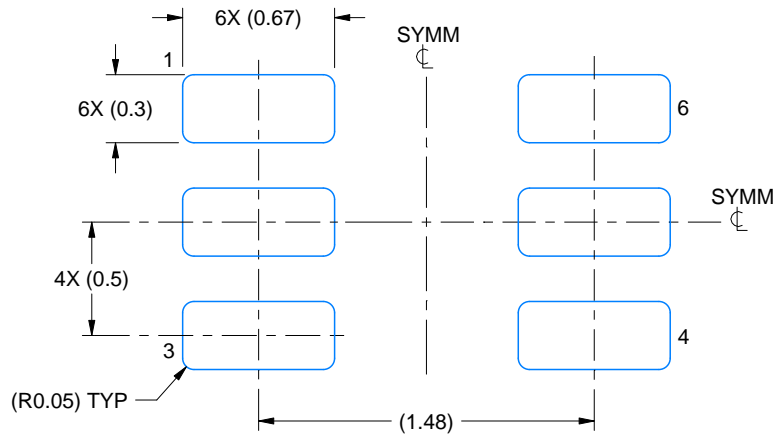

LAND PATTERN EXAMPLE  
SCALE:30X

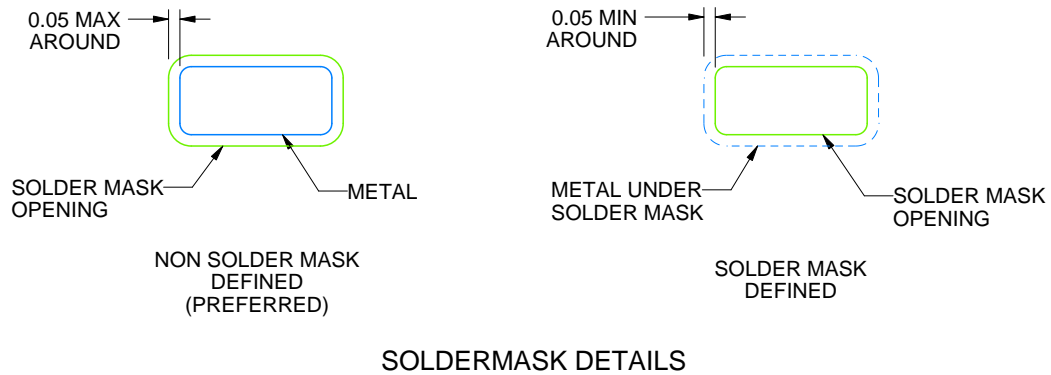

SOLDERMASK DETAILS

4223266/F 11/2024

NOTES: (continued)

5. Publication IPC-7351 may have alternate designs.
6. Solder mask tolerances between and around signal pads can vary based on board fabrication site.
7. Land pattern design aligns to IPC-610, Bottom Termination Component (BTC) solder joint inspection criteria.



# EXAMPLE STENCIL DESIGN

DRL0006A

SOT - 0.6 mm max height

PLASTIC SMALL OUTLINE

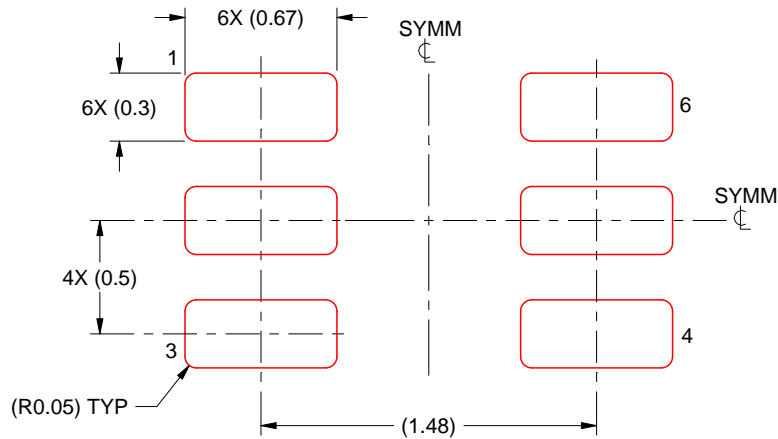

SOLDER PASTE EXAMPLE  
BASED ON 0.1 mm THICK STENCIL  
SCALE:30X

4223266/F 11/2024

NOTES: (continued)

8. Laser cutting apertures with trapezoidal walls and rounded corners may offer better paste release. IPC-7525 may have alternate design recommendations.
9. Board assembly site may have different recommendations for stencil design.

# DBV0006A



# PACKAGE OUTLINE

SOT-23 - 1.45 mm max height

SMALL OUTLINE TRANSISTOR

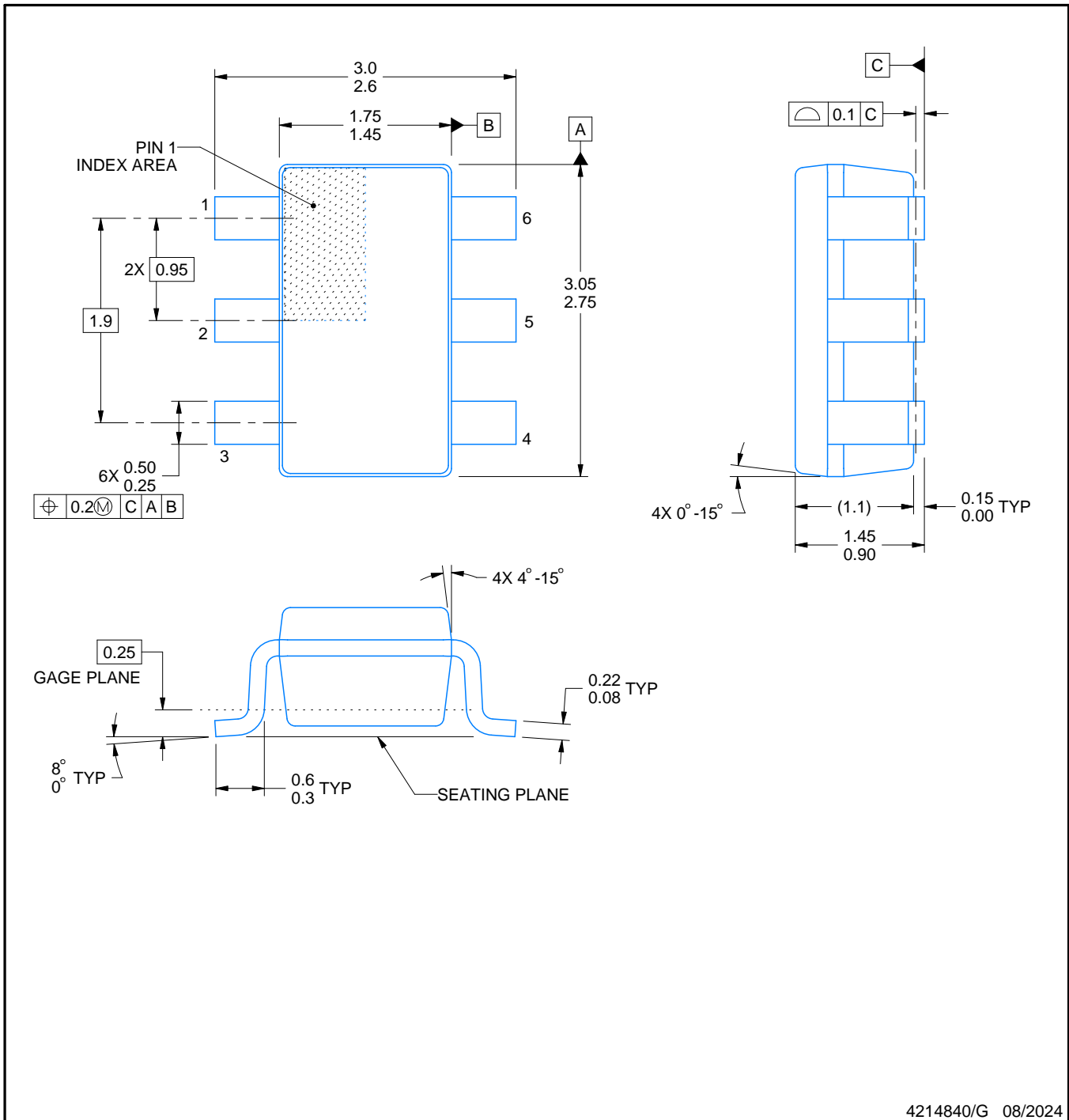

4214840/G 08/2024

**NOTES:**

1. All linear dimensions are in millimeters. Any dimensions in parenthesis are for reference only. Dimensioning and tolerancing per ASME Y14.5M.
2. This drawing is subject to change without notice.
3. Body dimensions do not include mold flash or protrusion. Mold flash and protrusion shall not exceed 0.25 per side.
4. Leads 1,2,3 may be wider than leads 4,5,6 for package orientation.
5. Reference JEDEC MO-178.

# EXAMPLE BOARD LAYOUT

DBV0006A

SOT-23 - 1.45 mm max height

SMALL OUTLINE TRANSISTOR



LAND PATTERN EXAMPLE  
EXPOSED METAL SHOWN  
SCALE:15X

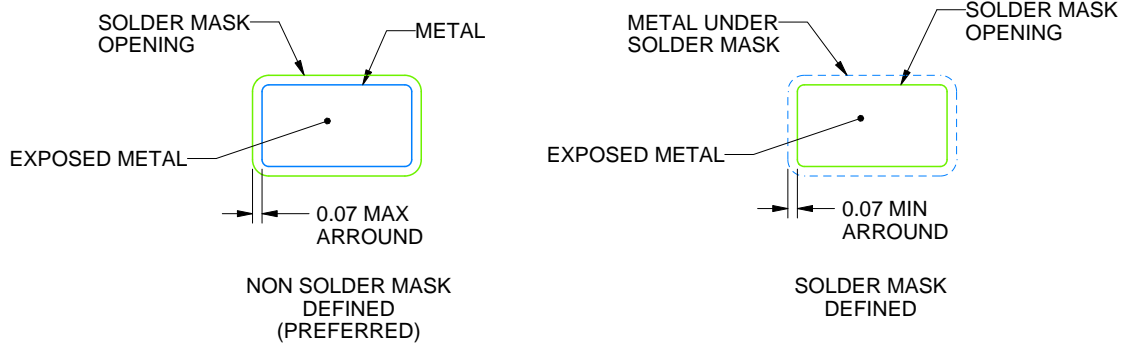

SOLDER MASK DETAILS

4214840/G 08/2024

NOTES: (continued)

6. Publication IPC-7351 may have alternate designs.

7. Solder mask tolerances between and around signal pads can vary based on board fabrication site.

# EXAMPLE STENCIL DESIGN

DBV0006A

SOT-23 - 1.45 mm max height

SMALL OUTLINE TRANSISTOR



SOLDER PASTE EXAMPLE  
BASED ON 0.125 mm THICK STENCIL  
SCALE:15X

4214840/G 08/2024

NOTES: (continued)

8. Laser cutting apertures with trapezoidal walls and rounded corners may offer better paste release. IPC-7525 may have alternate design recommendations.
9. Board assembly site may have different recommendations for stencil design.

DEA0006A



PACKAGE OUTLINE

X2SON - 0.4 mm max height

PLASTIC SMALL OUTLINE - NO LEAD

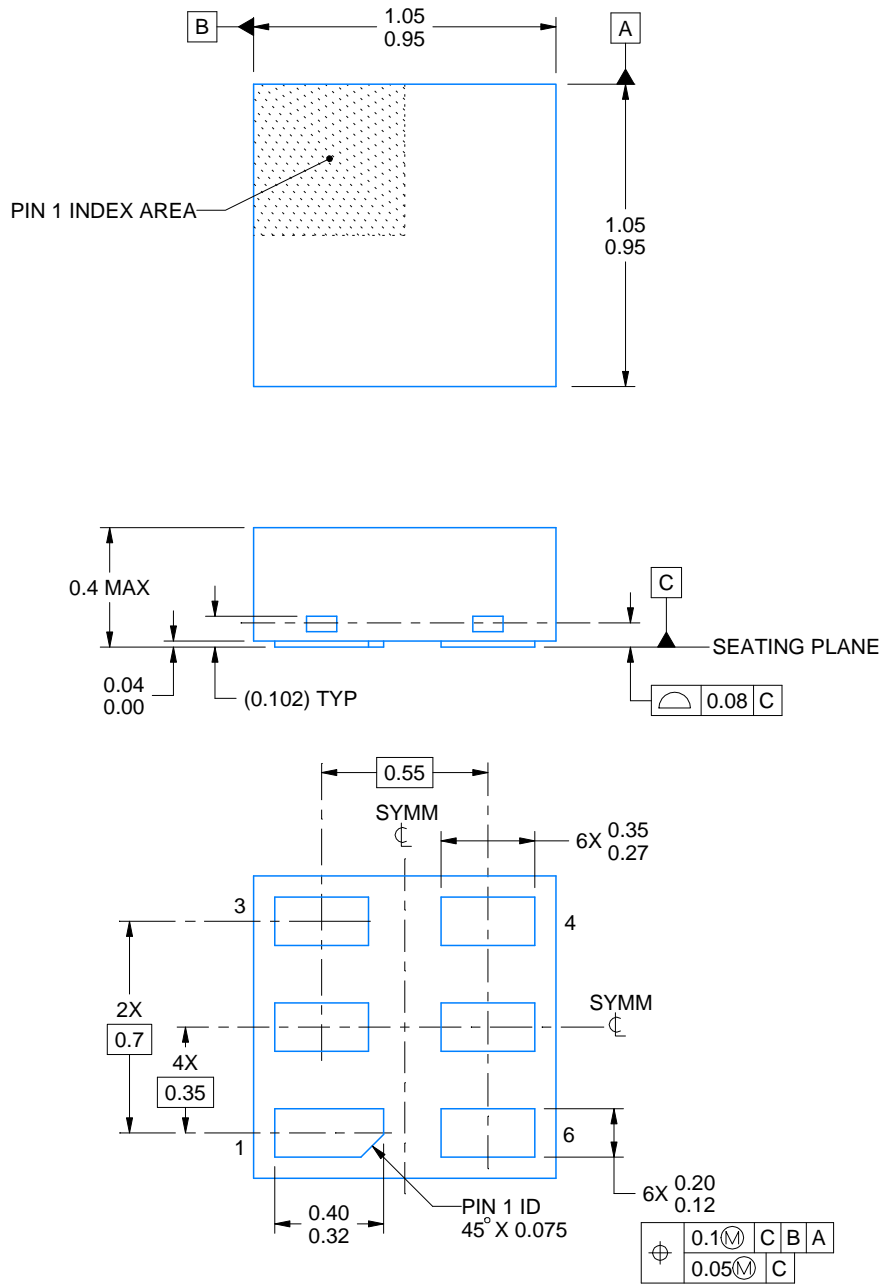

4223910/C 12/2017

NOTES:

1. All linear dimensions are in millimeters. Any dimensions in parenthesis are for reference only. Dimensioning and tolerancing per ASME Y14.5M.
2. This drawing is subject to change without notice.

# EXAMPLE BOARD LAYOUT

DEA0006A

X2SON - 0.4 mm max height

PLASTIC SMALL OUTLINE - NO LEAD

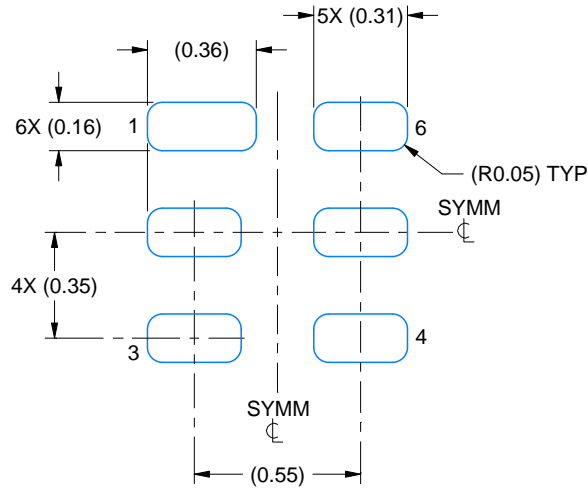

LAND PATTERN EXAMPLE  
EXPOSED METAL SHOWN  
SCALE:40X

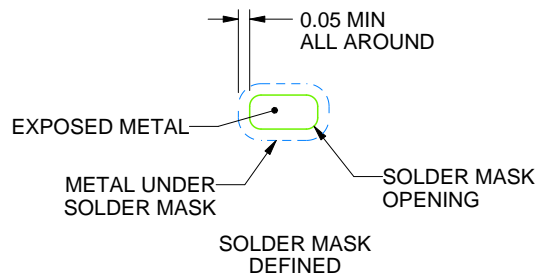

SOLDER MASK DETAILS

4223910/C 12/2017

NOTES: (continued)

3. For more information, see Texas Instruments literature number SLUA271 ([www.ti.com/lit/slua271](http://www.ti.com/lit/slua271)).

# EXAMPLE STENCIL DESIGN

DEA0006A

X2SON - 0.4 mm max height

PLASTIC SMALL OUTLINE - NO LEAD

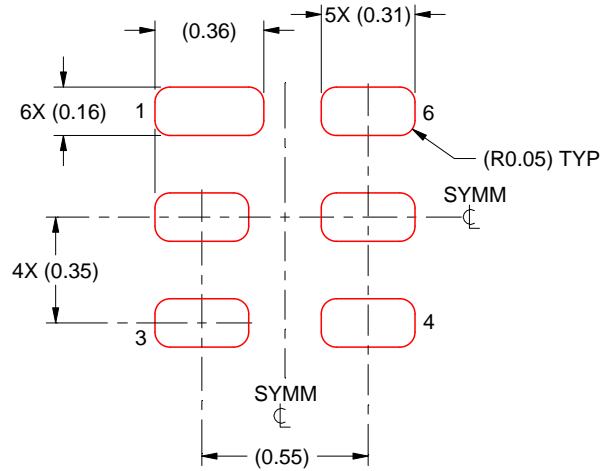

SOLDER PASTE EXAMPLE  
BASED ON 0.075 mm THICK STENCIL  
SCALE:40X

4223910/C 12/2017

4. Laser cutting apertures with trapezoidal walls and rounded corners may offer better paste release. IPC-7525 may have alternate design recommendations.

# DCK0006A



# PACKAGE OUTLINE

SOT - 1.1 max height

SMALL OUTLINE TRANSISTOR

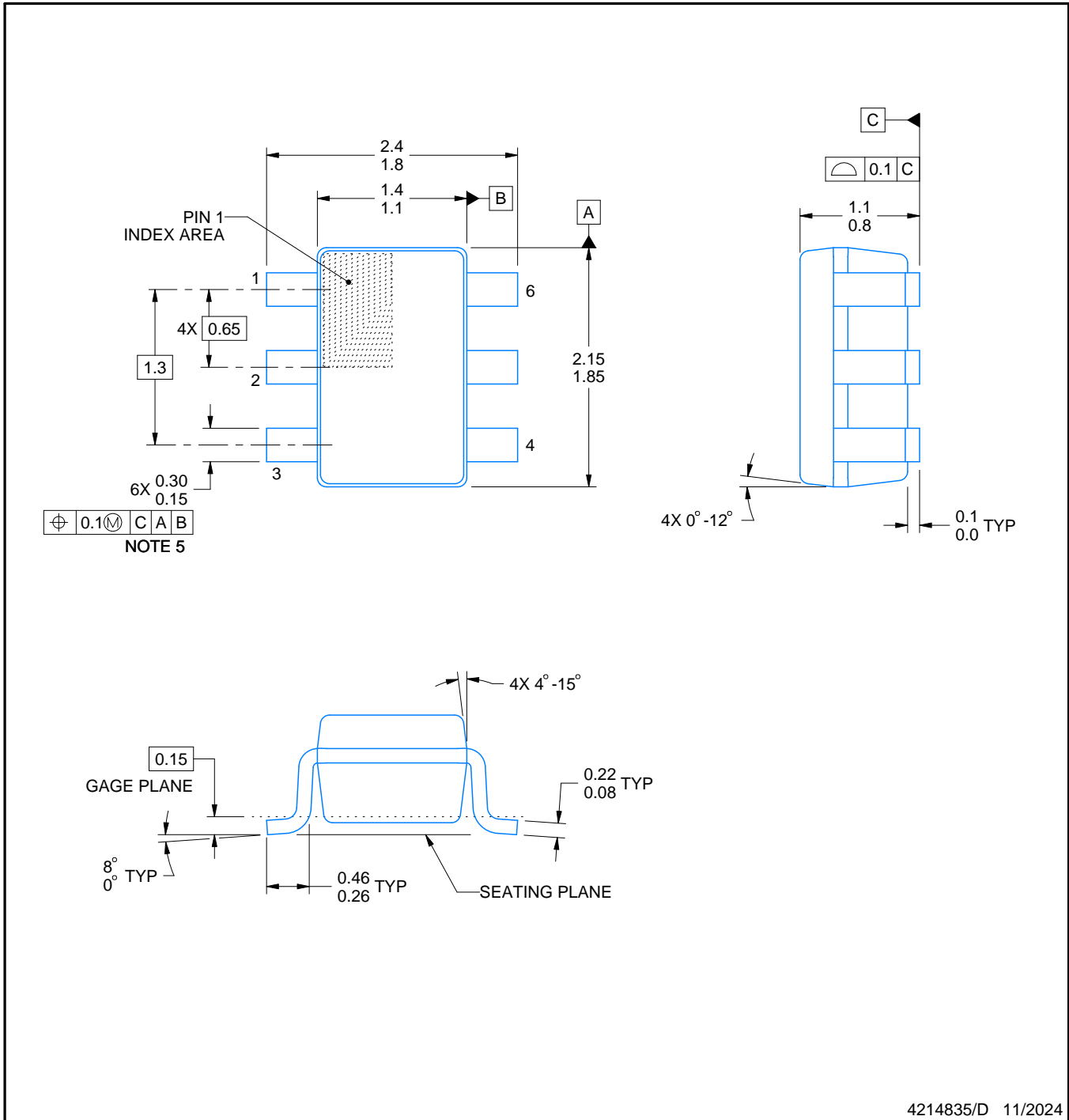

4214835/D 11/2024

## NOTES:

1. All linear dimensions are in millimeters. Any dimensions in parenthesis are for reference only. Dimensioning and tolerancing per ASME Y14.5M.
2. This drawing is subject to change without notice.
3. Body dimensions do not include mold flash or protrusion. Mold flash and protrusion shall not exceed 0.15 per side.
4. Falls within JEDEC MO-203 variation AB.



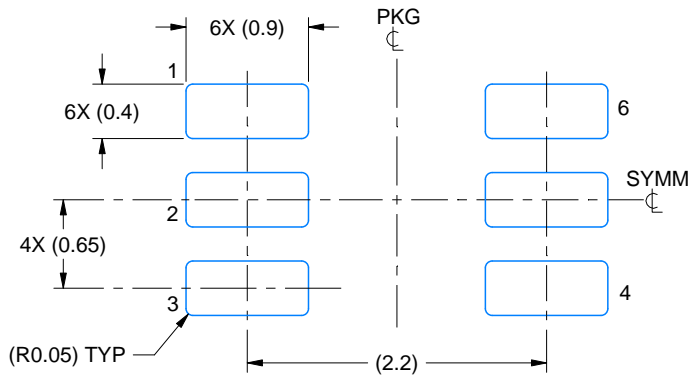

LAND PATTERN EXAMPLE  
EXPOSED METAL SHOWN  
SCALE:18X

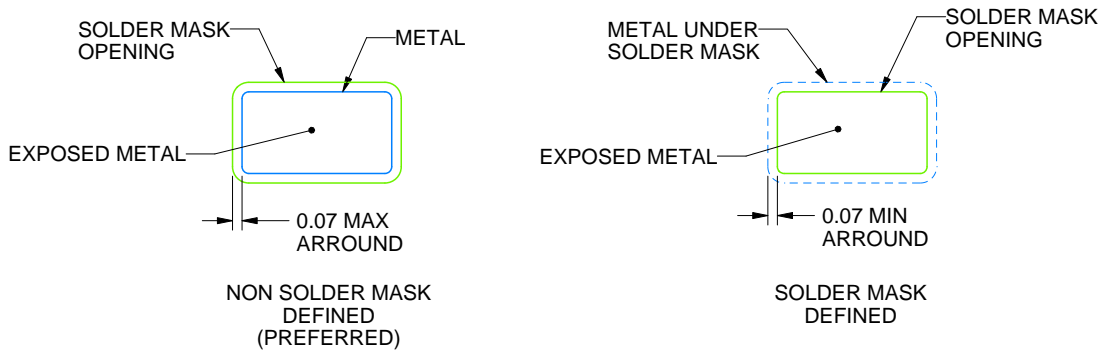

SOLDER MASK DETAILS

4214835/D 11/2024

NOTES: (continued)

5. Publication IPC-7351 may have alternate designs.
6. Solder mask tolerances between and around signal pads can vary based on board fabrication site.

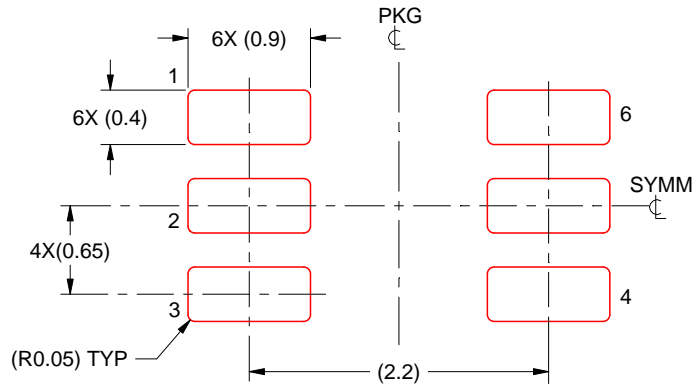

SOLDER PASTE EXAMPLE  
BASED ON 0.125 THICK STENCIL  
SCALE:18X

4214835/D 11/2024

NOTES: (continued)

7. Laser cutting apertures with trapezoidal walls and rounded corners may offer better paste release. IPC-7525 may have alternate design recommendations.
8. Board assembly site may have different recommendations for stencil design.

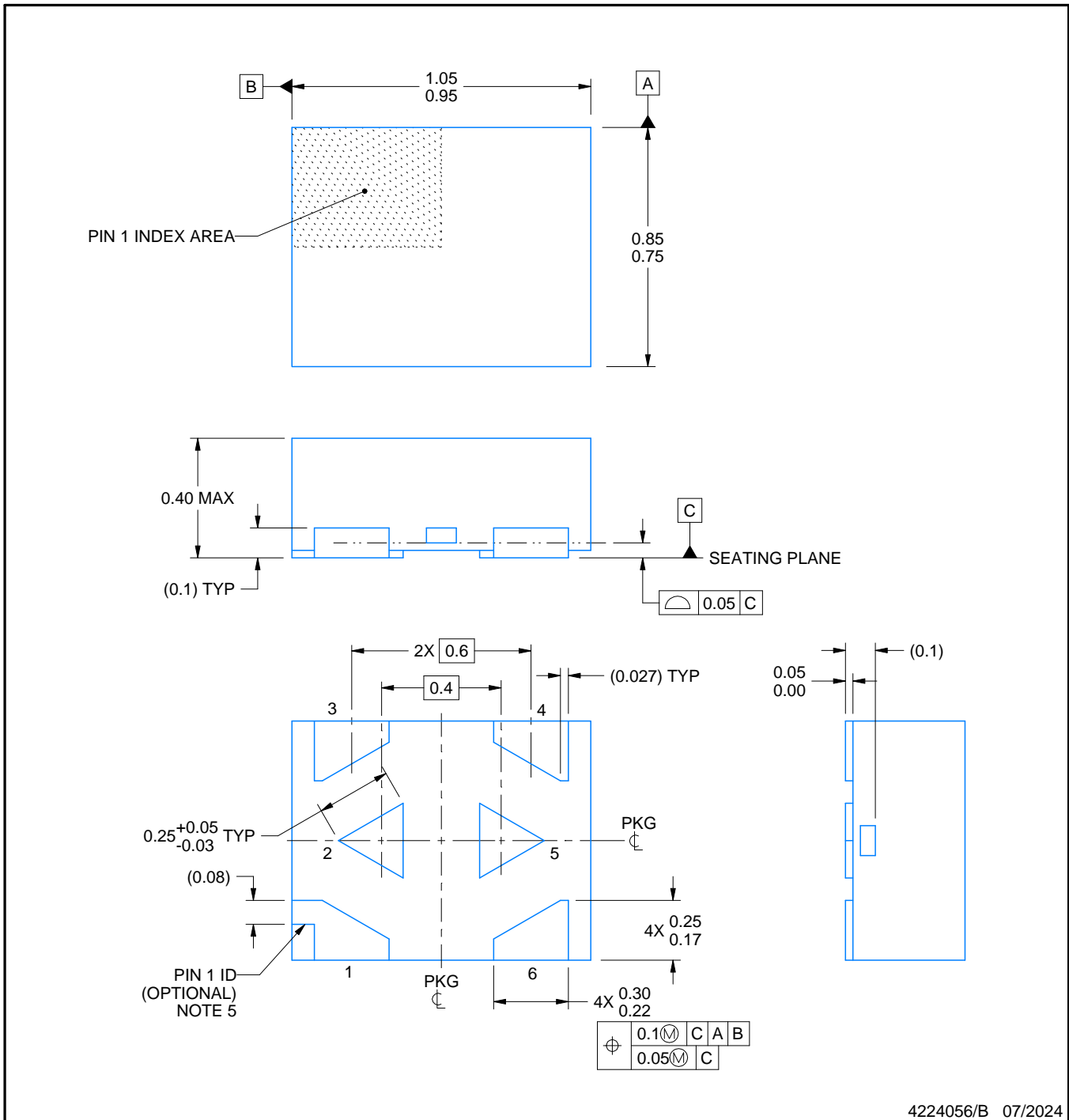

NOTES:

1. All linear dimensions are in millimeters. Any dimensions in parenthesis are for reference only. Dimensioning and tolerancing per ASME Y14.5M.
2. This drawing is subject to change without notice.
3. The package thermal pads must be soldered to the printed circuit board for optimal thermal and mechanical performance.
4. The size and shape of this feature may vary.
5. Features may not exist. Recommend use of pin 1 marking on top of package for orientation purposes.

# EXAMPLE BOARD LAYOUT

DTQ0006A

X2SON - 0.4 mm max height

PLASTIC SMALL OUTLINE - NO LEAD

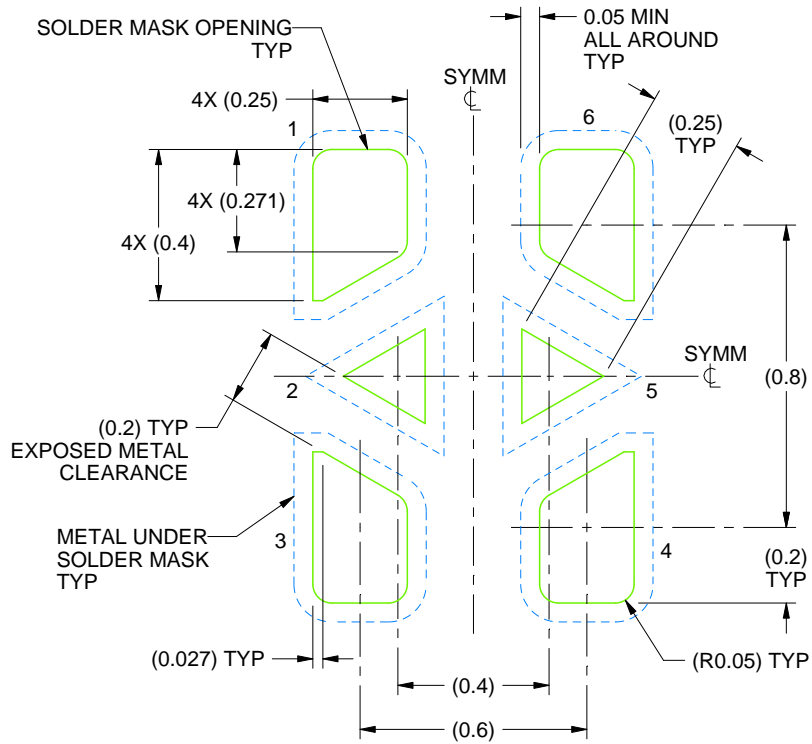

LAND PATTERN EXAMPLE  
SOLDER MASK DEFINED  
SCALE:50X

4224056/B 07/2024

NOTES: (continued)

6. This package is designed to be soldered to a thermal pads on the board. For more information, see Texas Instruments literature number SLUA271 ([www.ti.com/lit/slua271](http://www.ti.com/lit/slua271)).
7. Vias are optional depending on application, refer to device data sheet. If some or all are implemented, recommended via locations are shown.



## 重要なお知らせと免責事項

テキサス・インスツルメンツは、技術データと信頼性データ(データシートを含みます)、設計リソース(リファレンス デザインを含みます)、アプリケーションや設計に関する各種アドバイス、Web ツール、安全性情報、その他のリソースを、欠陥が存在する可能性のある「現状のまま」提供しており、商品性および特定目的に対する適合性の黙示保証、第三者の知的財産権の非侵害保証を含むいかなる保証も、明示的または黙示的にかかわらず拒否します。

これらのリソースは、テキサス・インスツルメンツ製品を使用する設計の経験を積んだ開発者への提供を意図したものです。(1) お客様のアプリケーションに適したテキサス・インスツルメンツ製品の選定、(2) お客様のアプリケーションの設計、検証、試験、(3) お客様のアプリケーションに該当する各種規格や、その他のあらゆる安全性、セキュリティ、規制、または他の要件への確実な適合に関する責任を、お客様のみが単独で負うものとし、ます。

上記の各種リソースは、予告なく変更される可能性があります。これらのリソースは、リソースで説明されているテキサス・インスツルメンツ製品を使用するアプリケーションの開発の目的でのみ、テキサス・インスツルメンツはその使用をお客様に許諾します。これらのリソースに関して、他の目的で複製することや掲載することは禁止されています。テキサス・インスツルメンツや第三者の知的財産権のライセンスが付与されている訳ではありません。お客様は、これらのリソースを自身で使用した結果発生するあらゆる申し立て、損害、費用、損失、責任について、テキサス・インスツルメンツおよびその代理人を完全に補償するものとし、テキサス・インスツルメンツは一切の責任を拒否します。

テキサス・インスツルメンツの製品は、[テキサス・インスツルメンツの販売条件](#)、または [ti.com](https://www.ti.com) やかかるテキサス・インスツルメンツ製品の関連資料などのいずれかを通じて提供する適用可能な条項の下で提供されています。テキサス・インスツルメンツがこれらのリソースを提供することは、適用されるテキサス・インスツルメンツの保証または他の保証の放棄の拡大や変更を意味するものではありません。

お客様がいかなる追加条項または代替条項を提案した場合でも、テキサス・インスツルメンツはそれらに異議を唱え、拒否します。

郵送先住所：Texas Instruments, Post Office Box 655303, Dallas, Texas 75265  
Copyright © 2025, Texas Instruments Incorporated