

SN74HCS72-Q1 車載認定済み、クリア/プリセット機能搭載、シュミット・トリガ入力、デュアル D タイプ負エッジ・トリガ・フリップ・フロップ

1 特長

- 車載アプリケーション用に AEC-Q100 認定済み
 - デバイス温度グレード 1: $-40^{\circ}\text{C} \sim +125^{\circ}\text{C}$ 、 T_A
 - デバイス HBM ESD 分類レベル 2
 - デバイス CDM ESD 分類レベル C6
- 広い動作電圧範囲: 2V~6V
- シュミット・トリガ入力により低速またはノイズの多い入力信号に対応
- 低消費電力
 - I_{CC} : 100nA (標準値)
 - 入力リーク電流: $\pm 100\text{nA}$ (標準値)
- 5V で $\pm 7.8\text{mA}$ の出力駆動能力

2 アプリケーション

- モメンタリ・スイッチからトグル・スイッチへの変換
- 低速エッジレート信号の入力
- ノイズの多い環境での動作
- ウェイクアップ・パターンによる CAN コントローラ電源のイネーブル

3 概要





このデバイスには、2 つの独立した D タイプ負エッジ・トリガ・フリップ・フロップが含まれています。すべての入力はシュミット・トリガを備えているため、低速またはノイズの多い入力信号にも対応できます。プリセット ($\overline{\text{PRE}}$) 入力が Low レベルのとき、出力は High になります。クリア ($\overline{\text{CLR}}$) 入力が Low レベルのとき、出力は Low にリセットされます。プリセット機能とクリア機能は非同期であり、他方の入力レベルとは無関係です。 $\overline{\text{PRE}}$ と $\overline{\text{CLR}}$ が非アクティブ (High) の場合、セットアップ時間の要件を満たすデータ (D) 入力のデータは、クロック ($\overline{\text{CLK}}$) パルスの負方向エッジで出力 (Q, $\overline{\text{Q}}$) に転送されます。ホールド時間が経過した後、データ (D) 入力のデータは、出力 (Q, $\overline{\text{Q}}$) のレベルに影響を及ぼさずに変化させることができます。

製品情報⁽¹⁾

型番	パッケージ	本体サイズ(公称)
SN74HCS72QDRQ1	SOIC (14)	8.70mm x 3.90mm
SN74HCS72QPWRQ1	TSSOP (14)	5.00mm x 4.40mm

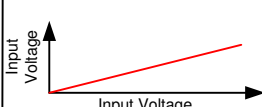
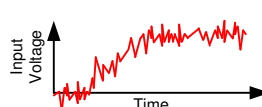
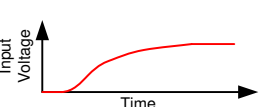
(1) 利用可能なすべてのパッケージについては、このデータシートの末尾にある注文情報を参照してください。

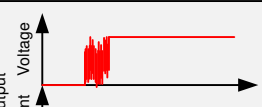
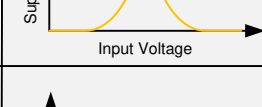
シュミットトリガ入力の利点

	Low Power	Noise Rejection	Supports Slow Inputs
Input Voltage Waveforms			
Standard CMOS Input Response Waveforms			
Schmitt-trigger CMOS Input Response Waveforms			

目次

1	特長	1	8.3	Feature Description	9
2	アプリケーション	1	8.4	Device Functional Modes	10
3	概要	1	9	Application and Implementation	11
4	改訂履歴	2	9.1	Application Information	11
5	Pin Configuration and Functions	3	9.2	Typical Application	11
6	Specifications	4	10	Power Supply Recommendations	13
6.1	Absolute Maximum Ratings	4	11	Layout	13
6.2	ESD Ratings	4	11.1	Layout Guidelines	13
6.3	Recommended Operating Conditions	4	11.2	Layout Example	13
6.4	Thermal Information	4	12	デバイスおよびドキュメントのサポート	14
6.5	Electrical Characteristics	5	12.1	ドキュメントのサポート	14
6.6	Switching Characteristics	5	12.2	ドキュメントの更新通知を受け取る方法	14
6.7	Timing Characteristics	6	12.3	コミュニティ・リソース	14
6.8	Typical Characteristics	7	12.4	商標	14
7	Parameter Measurement Information	8	12.5	静電気放電に関する注意事項	14
8	Detailed Description	9	12.6	Glossary	14
8.1	Overview	9	13	メカニカル、パッケージ、および注文情報	14
8.2	Functional Block Diagram	9			

4 改訂履歴

日付	リビジョン	注
2019年10月	*	初版

5 Pin Configuration and Functions

**D and PW Package
14-Pin SOIC and TSSOP
Top View**

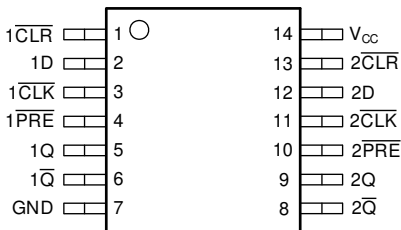

Pin Functions

PIN		TYPE	DESCRIPTION
NAME	NO.		
1 $\overline{\text{CLR}}$	1	Input	Clear for channel 1, active low
1D	2	Input	Data for channel 1
1 $\overline{\text{CLK}}$	3	Input	Clock for channel 1, falling edge triggered
1 $\overline{\text{PRE}}$	4	Input	Preset for channel 1, active low
1Q	5	Output	Output for channel 1
1 $\overline{\text{Q}}$	6	Output	Inverted output for channel 1
GND	7	—	Ground
2 $\overline{\text{Q}}$	8	Output	Inverted output for channel 2
2Q	9	Output	Output for channel 2
2 $\overline{\text{PRE}}$	10	Input	Preset for channel 2, active low
2 $\overline{\text{CLK}}$	11	Input	Clock for channel 2, falling edge triggered
2D	12	Input	Data for channel 2
2 $\overline{\text{CLR}}$	13	Input	Clear for channel 2, active low
V _{CC}	14	—	Positive supply

6 Specifications

6.1 Absolute Maximum Ratings

over operating free-air temperature range (unless otherwise noted)⁽¹⁾

			MIN	MAX	UNIT
V _{CC}	Supply voltage		-0.5	7	V
I _{IK}	Input clamp current ⁽²⁾	V _I < 0 or V _I > V _{CC} + 0.5 V		±20	mA
I _{OK}	Output clamp current ⁽²⁾	V _O < 0 or V _O > V _{CC} + 0.5 V		±20	mA
I _O	Continuous output current	V _O = 0 to V _{CC}		±25	mA
	Continuous current through V _{CC} or GND			±50	mA
T _j	Junction temperature ⁽³⁾			150	°C
T _{stg}	Storage temperature		-65	150	°C

- (1) Stresses beyond those listed under *Absolute Maximum Rating* may cause permanent damage to the device. These are stress ratings only, which do not imply functional operation of the device at these or any other conditions beyond those indicated under *Recommended Operating Condition*. Exposure to absolute-maximum-rated conditions for extended periods may affect device reliability.
- (2) The input and output voltage ratings may be exceeded if the input and output current ratings are observed.
- (3) Guaranteed by design

6.2 ESD Ratings

			VALUE	UNIT
V _(ESD)	Electrostatic discharge	Human body model (HBM), per AEC Q100-002 ⁽¹⁾ HBM ESD Classification Level 2	±4000	V
		Charged device model (CDM), per AEC Q100-011 CDM ESD Classification Level C4B	±1000	

- (1) AEC Q100-002 indicate that HBM stressing shall be in accordance with the ANSI/ESDA/JEDEC JS-001 specification.

6.3 Recommended Operating Conditions

over operating free-air temperature range (unless otherwise noted)

			MIN	NOM	MAX	UNIT
V _{CC}	Supply voltage		2	5	6	V
V _I	Input voltage		0		V _{CC}	V
V _O	Output voltage		0		V _{CC}	V
Δt/Δv	Input transition rise and fall rate				Unlimited	ns/V
T _A	Ambient temperature		-40		125	°C

6.4 Thermal Information

THERMAL METRIC		SN74HCS72-Q1		UNIT
		D (SOIC)	PW (TSSOP)	
		14 PINS	14 PINS	
R _{θJA}	Junction-to-ambient thermal resistance	133.6	151.7	°C/W
R _{θJC(top)}	Junction-to-case (top) thermal resistance	89	79.4	°C/W
R _{θJB}	Junction-to-board thermal resistance	89.5	94.7	°C/W
Ψ _{JT}	Junction-to-top characterization parameter	45.5	25.2	°C/W
Ψ _{JB}	Junction-to-board characterization parameter	89.1	94.1	°C/W
R _{θJC(bot)}	Junction-to-case (bottom) thermal resistance	N/A	N/A	°C/W

6.5 Electrical Characteristics

over operating free-air temperature range; typical values measured at $T_A = 25^\circ\text{C}$ (unless otherwise noted)

PARAMETER		TEST CONDITIONS		V_{CC}	MIN	TYP	MAX	UNIT
V_{T+}	Positive switching threshold			2 V	0.7		1.5	V
				4.5 V	1.7		3.15	
				6 V	2.1		4.2	
V_{T-}	Negative switching threshold			2 V	0.3		1.0	V
				4.5 V	0.9		2.2	
				6 V	1.2		3.0	
ΔV_T	Hysteresis ($V_{T+} - V_{T-}$) ⁽¹⁾			2 V	0.2		1.0	V
				4.5 V	0.4		1.4	
				6 V	0.6		1.6	
V_{OH}	High-level output voltage	$V_I = V_{IH}$ or V_{IL}	$I_{OH} = -20 \mu\text{A}$	2 V to 6 V	$V_{CC} - 0.1$	$V_{CC} - 0.002$		V
			$I_{OH} = -6 \text{ mA}$	4.5 V	4	4.3		
			$I_{OH} = -7.8 \text{ mA}$	6 V	5.4	5.75		
V_{OL}	Low-level output voltage	$V_I = V_{IH}$ or V_{IL}	$I_{OL} = 20 \mu\text{A}$	2 V to 6 V		0.002	0.1	V
			$I_{OL} = 6 \text{ mA}$	4.5 V		0.18	0.30	
			$I_{OL} = 7.8 \text{ mA}$	6 V		0.22	0.33	
I_I	Input leakage current	$V_I = V_{CC}$ or 0		6 V		± 100	± 1000	nA
I_{CC}	Supply current	$V_I = V_{CC}$ or 0, $I_O = 0$		6 V		0.1	2	μA
C_i	Input capacitance			2 V to 6 V			5	pF
C_{pd}	Power dissipation capacitance per gate	No load		2 V to 6 V		10		pF

(1) Guaranteed by design.

6.6 Switching Characteristics

 $C_L = 50 \text{ pF}$; over operating free-air temperature range; typical values measured at $T_A = 25^\circ\text{C}$ (unless otherwise noted). See [Parameter Measurement Information](#)

PARAMETER		FROM (INPUT)	TO (OUTPUT)	V_{CC}	MIN	TYP	MAX	UNIT
f_{max}	Max switching frequency			2 V	20	31		MHz
				4.5 V	64	95		
				6 V	74	105		
t_{pd}	Propagation delay	$\overline{\text{PRE}}$ or $\overline{\text{CLR}}$	Q or \overline{Q}	2 V		19	42	ns
				4.5 V		8	19	
				6 V		7	15	
		$\overline{\text{CLK}}$	Q or \overline{Q}	2 V		19	42	ns
				4.5 V		8	19	
				6 V		7	15	
t_t	Transition-time ⁽¹⁾			2 V		9	16	ns
				4.5 V		5	9	
				6 V		4	8	

(1) $t_t = t_r$ or t_f , whichever is larger

6.7 Timing Characteristics

$C_L = 50$ pF; over operating free-air temperature range; typical values measured at $T_A = 25^\circ\text{C}$ (unless otherwise noted). See [Parameter Measurement Information](#).

PARAMETER			V_{CC}	MIN	TYP	MAX	UNIT
f_{clock}	Clock frequency		2 V			20	MHz
			4.5 V			64	
			6 V			74	
t_w	Pulse duration	$\overline{\text{PRE}}$ or $\overline{\text{CLR}}$ low	2 V	8	7		ns
			4.5 V	7	5		
			6 V	7	5		
		$\overline{\text{CLK}}$ high or low	2 V	10	5		ns
			4.5 V	9	3		
			6 V	8	2		
t_{su}	Setup time before $\overline{\text{CLK}}$ low	Data	2 V	16	11		ns
			4.5 V	6	1		
			6 V	3	1		
		$\overline{\text{PRE}}$ or $\overline{\text{CLR}}$ inactive	2 V	7			ns
			4.5 V	0			
			6 V	0			
t_h	Hold time	Data after CLK ↓	2 V	5			ns
			4.5 V	3			
			6 V	2			

6.8 Typical Characteristics

$T_A = 25^\circ\text{C}$

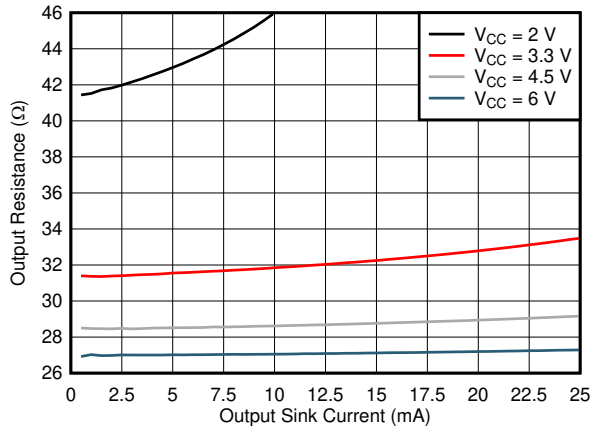

Fig 1. Output driver resistance in LOW state.

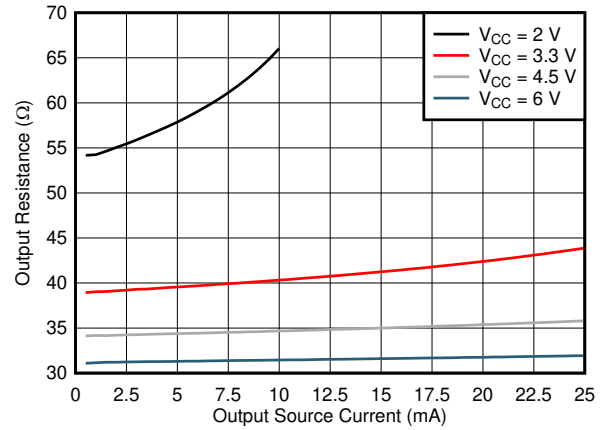

Fig 2. Output driver resistance in HIGH state.

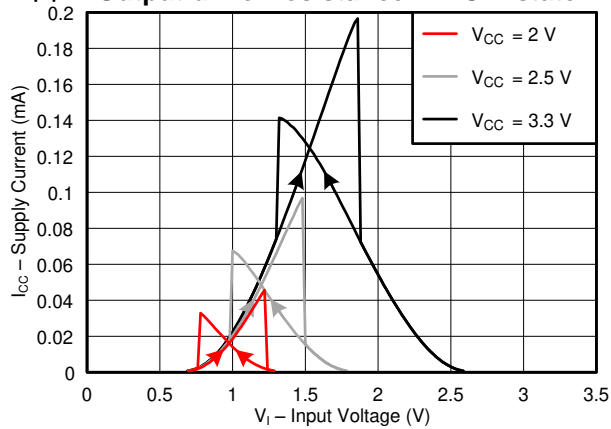

Fig 3. Supply current across input voltage, 2-, 2.5-, and 3.3-V supply

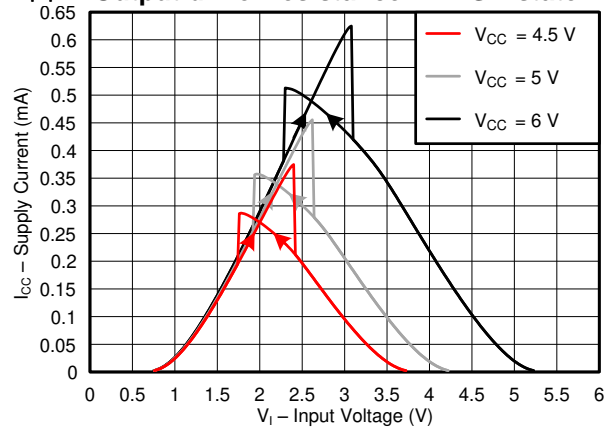

Fig 4. Supply current across input voltage, 4.5-, 5-, and 6-V supply

7 Parameter Measurement Information

Phase relationships between waveforms were chosen arbitrarily. All input pulses are supplied by generators having the following characteristics: PRR \leq 1 MHz, $Z_O = 50 \Omega$, $t_t < 2.5$ ns.

For clock inputs, f_{max} is measured when the input duty cycle is 50%.

The outputs are measured one at a time with one input transition per measurement.

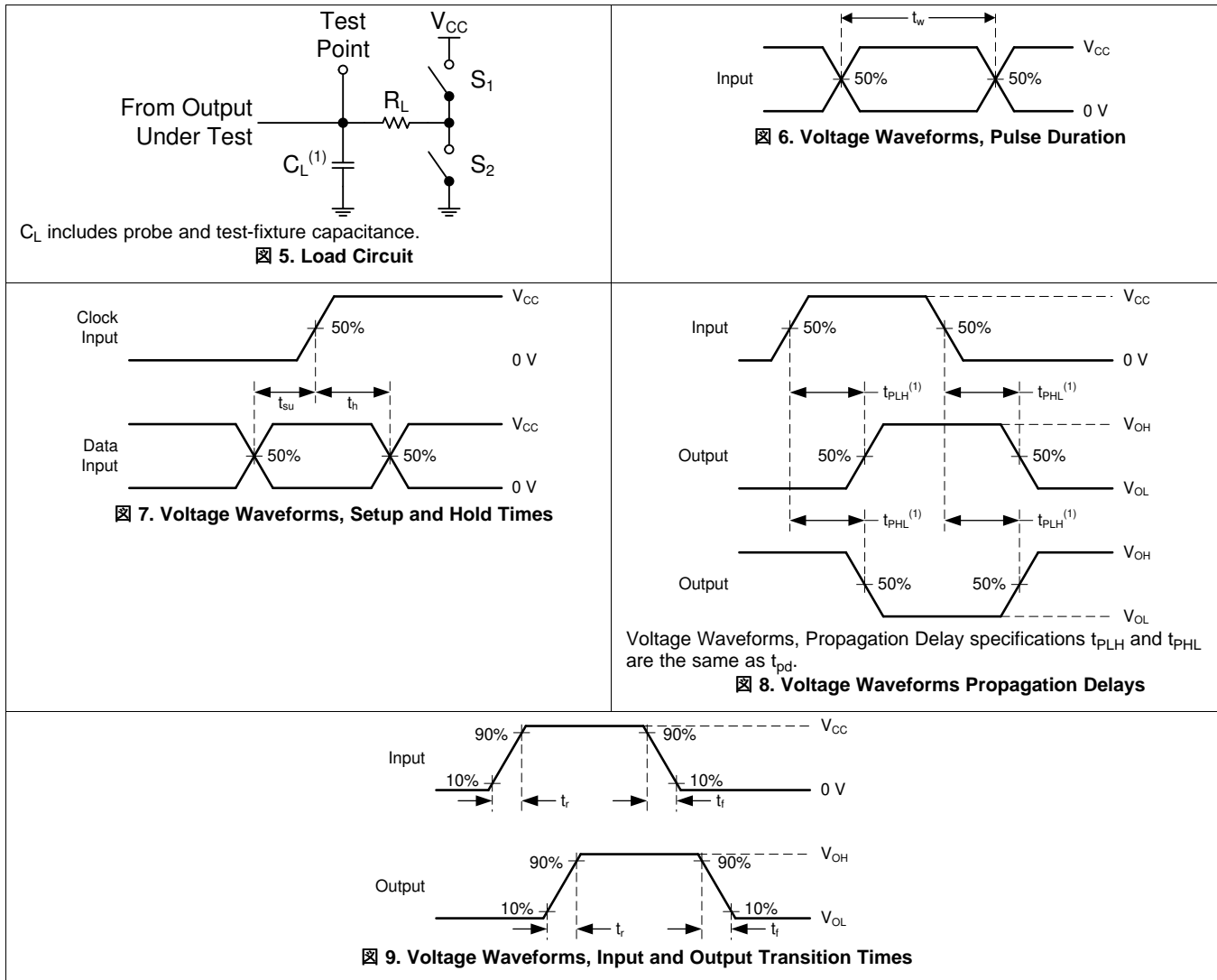

8 Detailed Description

8.1 Overview

Figure 10 describes the SN74HCS72-Q1. As the SN74HCS72-Q1 is a dual D-Type negative-edge-triggered flip-flop with clear and preset, the diagram below describes one of the two device flip-flops.

8.2 Functional Block Diagram

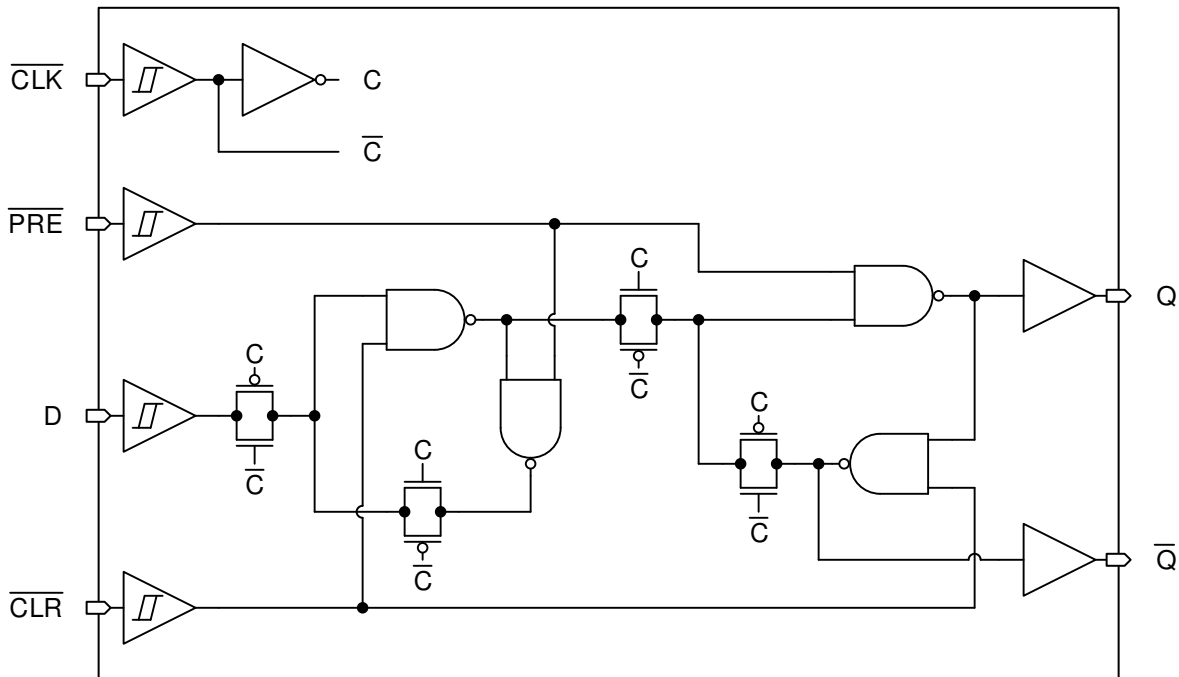

Figure 10. Logic Diagram (Positive Logic) for one channel of SN74HCS72-Q1

8.3 Feature Description

8.3.1 Balanced CMOS Push-Pull Outputs

A balanced output allows the device to sink and source similar currents. The drive capability of this device may create fast edges into light loads so routing and load conditions should be considered to prevent ringing. Additionally, the outputs of this device are capable of driving larger currents than the device can sustain without being damaged. It is important for the output power of the device to be limited to avoid damage due to over-current. The electrical and thermal limits defined in the [Absolute Maximum Ratings](#) must be followed at all times.

8.3.2 CMOS Schmitt-Trigger Inputs

Standard CMOS inputs are high impedance and are typically modeled as a resistor in parallel with the input capacitance given in the [Electrical Characteristics](#). The worst case resistance is calculated with the maximum input voltage, given in the [Absolute Maximum Ratings](#), and the maximum input leakage current, given in the [Electrical Characteristics](#), using ohm's law ($R = V \div I$).

The Schmitt-trigger input architecture provides hysteresis as defined by ΔV_T in the [Electrical Characteristics](#), which makes this device extremely tolerant to slow or noisy inputs. While the inputs can be driven much slower than standard CMOS inputs, it is still recommended to properly terminate unused inputs. Driving the inputs slowly will also increase dynamic current consumption of the device. For additional information regarding Schmitt-trigger inputs, please see [Understanding Schmitt Triggers](#).

Feature Description (continued)

8.3.3 Positive and Negative Clamping Diodes

The inputs and outputs to this device have both positive and negative clamping diodes as depicted in [Figure 11](#).

注意

Voltages beyond the values specified in the *Absolute Maximum Ratings* table can cause damage to the device. The input negative-voltage and output voltage ratings may be exceeded if the input and output clamp-current ratings are observed.

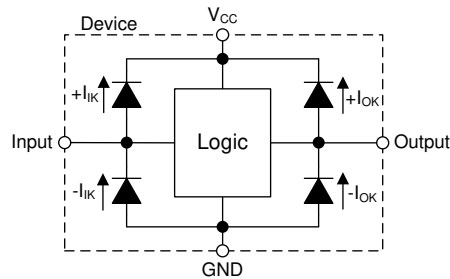

Figure 11. Electrical Placement of Clamping Diodes for Each Input and Output

8.4 Device Functional Modes

[Table 1](#) lists the functional modes of the SN74HCS72-Q1.

Table 1. Function Table

INPUTS				OUTPUTS	
$\overline{\text{PRE}}$	$\overline{\text{CLR}}$	$\overline{\text{CLK}}$	D	Q	$\overline{\text{Q}}$
L	H	X	X	H	L
H	L	X	X	L	H
L	L	X	X	H ⁽¹⁾	H ⁽¹⁾
H	H	↓	H	H	L
H	H	↓	L	L	H
H	H	L	X	Q ₀	$\overline{\text{Q}}_0$
H	H	H	X	Q ₀	$\overline{\text{Q}}_0$

(1) This configuration is nonstable; that is, it does not persist when $\overline{\text{PRE}}$ or $\overline{\text{CLR}}$ returns to its inactive (high) level.

9 Application and Implementation

注

Information in the following applications sections is not part of the TI component specification, and TI does not warrant its accuracy or completeness. TI's customers are responsible for determining suitability of components for their purposes. Customers should validate and test their design implementation to confirm system functionality.

9.1 Application Information

The SN74HCS72-Q1 is an ideal device for taking a CAN wake-up request and converting it to a power supply enable due to its low power consumption and noise rejecting inputs, which eliminate false triggers. CAN communication can occur when the vehicle ignition is off. Therefore, many circuits are designed to work in a standby or low power mode. Because a CAN wake-up request causes the RX pin to pulse LOW, the SN74HCS72-Q1 will trigger off the falling edge enabling the power for the CAN controller. Then the CAN controller powers on for the incoming communication. When communications are finished, the controller sends a reset pulse to the SN74HCS72-Q1 and CAN transceiver putting the circuit back into a standby mode.

9.2 Typical Application



图 12. Power Enable Using CAN Wake-up Request

9.2.1 Design Requirements

The SN74HCS72-Q1 device allows flexibility by having complementary outputs for active-high or active-low enables. The supply should be selected such that the device is always powered along with the CAN transceiver. The same supply for both devices is recommended.

With the SN74HCS72-Q1, a power on reset circuit only requires a resistor (R) and capacitor (C) to create a delay. The R and C values create a delay that is approximately $2.2 \times RC$. In this application, it is desired to have the output (\bar{Q}) in the HIGH state at startup, so R1 and C1 are connected directly to the \bar{CLR} pin, as shown in 图 12. A second resistor is needed to limit the current into the CAN controller when it sets the circuit back into standby mode. It is required for the R1 resistor to be at least ten times larger than R2 to avoid a divider circuit ($R2 \leq 10R1$).

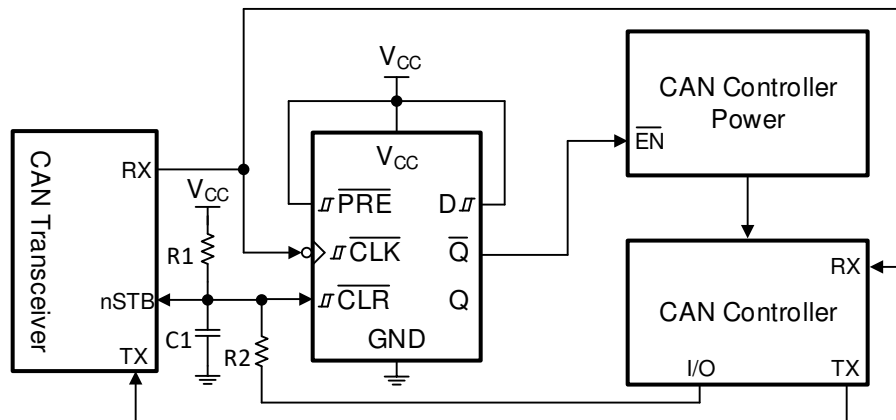
The D input can be tied either to V_{CC} or ground depending on the desired implementation. In this example, it is tied to V_{CC} to obtain a HIGH signal from \bar{Q} when a wake-up request occurs.

Typical Application (continued)

9.2.1.1 Output Considerations

In general, the load needs to be considered in the design to determine if the device will have the capability to drive it. For this application, we assume that the flip-flop output is transmitting over a relatively short trace (under 10 cm) to a CMOS input.

Primary load factors to consider:

- Load Capacitance: approximately 15 pF
 - See the [Switching Characteristics](#) section for the capacitive loads tested with this device.
 - Increasing capacitance will proportionally increase output transition times.
 - Decreasing capacitance will proportionally decrease output transition times, and can produce ringing due to very fast transition rates. A 25-Ω resistor can be added in series with the output if ringing needs to be dampened.
- Load Current: expected maximum of 10 μA
 - Leakage current into connected devices.
 - Parasitic current from other components.
 - Resistive load current.
- Output Voltage: see [Electrical Characteristics](#) for output voltage ratings at a given current.
 - Output HIGH (V_{OH}) and output LOW (V_{OL}) voltage levels affect the input voltage, V_{IH} and V_{IL} , respectively, to subsequent devices.

9.2.1.2 Input Considerations

The SN74HCS72-Q1 has Schmitt-trigger inputs. Schmitt-trigger inputs have no limitation on transition rate, however the input voltage must be larger than $V_{T+(max)}$ to be guaranteed to be read as a logic high, and below $V_{T-(min)}$ to be guaranteed to be read as a logic low, as defined in the [Electrical Characteristics](#). Do not exceed the values specified in the [Absolute Maximum Ratings](#) or the device could be damaged.

9.2.1.3 Timing Considerations

The SN74HCS72-Q1 is a clocked device. As such, it requires special timing considerations to ensure normal operation.

Primary timing factors to consider:

- Maximum clock frequency: the maximum operating clock frequency defined in [Timing Characteristics](#) is the maximum frequency at which the device is guaranteed to function. This value refers specifically to the triggering waveform, measuring from one trigger level to the next.
- Pulse duration: ensure that the triggering event duration is larger than the minimum pulse duration, as defined in the [Timing Characteristics](#).
- Setup time: ensure that the data has changed at least one setup time prior to the triggering event, as defined in the [Timing Characteristics](#).
- Hold time: ensure that the data remains in the desired state at least one hold time after the triggering event, as defined in the [Timing Characteristics](#).

9.2.2 Detailed Design Procedure

1. Recommended Input Conditions:

- Input signals to Schmitt-trigger inputs, like those found on the HCS family of devices, can support unlimited edge rates.
- Input thresholds are listed in the [Electrical Characteristics](#).
- Inputs include positive clamp diodes. Input voltages can exceed the device's supply so long as the clamp current ratings are observed from the [Absolute Maximum Ratings](#). Do not exceed the absolute maximum voltage rating of the device or it could be damaged.

2. Recommended Output Conditions:

- Load currents should not exceed the value listed in the [Absolute Maximum Ratings](#).
- Series resistors on the output may be used if the user desires to slow the output edge signal or limit the

Typical Application (continued)

output current.

9.2.3 Application Curve

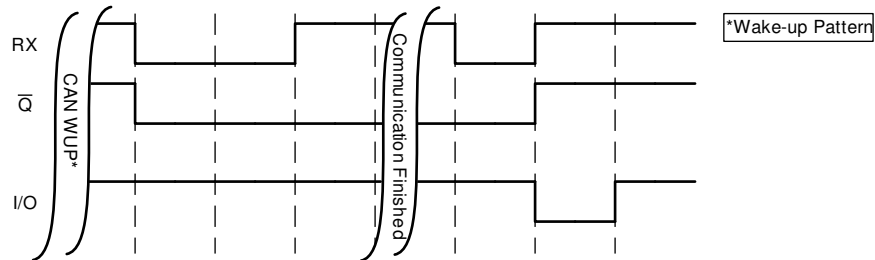

Figure 13. Application timing diagram

10 Power Supply Recommendations

The power supply can be any voltage between the minimum and maximum supply voltage rating located in the *Absolute Maximum Ratings* table. Each V_{CC} terminal should have a bypass capacitor to prevent power disturbance. For this device, a 0.1- μ F capacitor is recommended. It is acceptable to parallel multiple bypass caps to reject different frequencies of noise. The 0.1- μ F and 1- μ F capacitors are commonly used in parallel. The bypass capacitor should be installed as close to the power terminals as possible for best results.

11 Layout

11.1 Layout Guidelines

In many cases, functions or parts of functions of digital logic devices are unused. Some examples are when only two inputs of a triple-input AND gate are used, or when only 3 of the 4 channels are used. Such input pins should not be left completely unconnected because the unknown voltages result in undefined operational states.

Specified in Figure 14 are rules that must be observed under all circumstances. All unused inputs of digital logic devices must be connected to a high or low bias to prevent them from floating. The logic level that must be applied to any particular unused input depends on the function of the device. Generally they are tied to GND or V_{CC} , whichever makes more sense or is more convenient. It is recommended to float outputs unless the part is a transceiver. If the transceiver has an output enable pin, it disables the output section of the part when asserted. This pin keeps the input section of the I/Os from being disabled and floated.

11.2 Layout Example

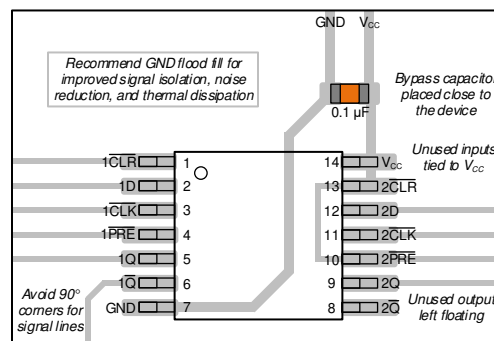

Figure 14. Layout Example

12 デバイスおよびドキュメントのサポート

12.1 ドキュメントのサポート

12.1.1 関連資料

関連資料については、以下を参照してください。

- テキサス・インスツルメンツ、『[Implications of Slow or Floating CMOS Inputs](#)』アプリケーション・レポート (英語)
- テキサス・インスツルメンツ、『[Reduce Noise and Save Power with the New HCS Logic Family](#)』アプリケーション・レポート (英語)
- テキサス・インスツルメンツ、『[Understanding Schmitt Triggers](#)』アプリケーション・レポート (英語)

12.2 ドキュメントの更新通知を受け取る方法

ドキュメントの更新についての通知を受け取るには、ti.comのデバイス製品フォルダを開いてください。右上の「アラートを受け取る」をクリックして登録すると、変更されたすべての製品情報に関するダイジェストを毎週受け取れます。変更の詳細については、修正されたドキュメントに含まれている改訂履歴をご覧ください。

12.3 コミュニティ・リソース

[TI E2E™ support forums](#) are an engineer's go-to source for fast, verified answers and design help — straight from the experts. Search existing answers or ask your own question to get the quick design help you need.

Linked content is provided "AS IS" by the respective contributors. They do not constitute TI specifications and do not necessarily reflect TI's views; see TI's [Terms of Use](#).

12.4 商標

E2E is a trademark of Texas Instruments.

12.5 静電気放電に関する注意事項



これらのデバイスは、限定的なESD(静電破壊)保護機能を内蔵しています。保存時または取り扱い時は、MOSゲートに対する静電破壊を防止するために、リード線同士をショートさせておくか、デバイスを導電フォームに入れる必要があります。

12.6 Glossary

[SLYZ022](#) — *TI Glossary*.

This glossary lists and explains terms, acronyms, and definitions.

13 メカニカル、パッケージ、および注文情報

以降のページには、メカニカル、パッケージ、および注文に関する情報が記載されています。これらの情報は、指定のデバイスに対して提供されている最新のデータです。このデータは予告なく変更されることがあり、ドキュメントが改訂される場合もあります。このデータシートのブラウザ対応版については、左側にあるナビゲーションを参照してください。

PACKAGING INFORMATION

Orderable Device	Status (1)	Package Type	Package Drawing	Pins	Package Qty	Eco Plan (2)	Lead finish/ Ball material (6)	MSL Peak Temp (3)	Op Temp (°C)	Device Marking (4/5)	Samples
SN74HCS72QDRQ1	ACTIVE	SOIC	D	14	2500	RoHS & Green	NIPDAU	Level-1-260C-UNLIM	-40 to 125	HCS72Q1	Samples
SN74HCS72QPWRQ1	ACTIVE	TSSOP	PW	14	2000	RoHS & Green	NIPDAU	Level-1-260C-UNLIM	-40 to 125	HCS72Q	Samples

(1) The marketing status values are defined as follows:

ACTIVE: Product device recommended for new designs.

LIFEBUY: TI has announced that the device will be discontinued, and a lifetime-buy period is in effect.

NRND: Not recommended for new designs. Device is in production to support existing customers, but TI does not recommend using this part in a new design.

PREVIEW: Device has been announced but is not in production. Samples may or may not be available.

OBSOLETE: TI has discontinued the production of the device.

(2) **RoHS:** TI defines "RoHS" to mean semiconductor products that are compliant with the current EU RoHS requirements for all 10 RoHS substances, including the requirement that RoHS substance do not exceed 0.1% by weight in homogeneous materials. Where designed to be soldered at high temperatures, "RoHS" products are suitable for use in specified lead-free processes. TI may reference these types of products as "Pb-Free".

RoHS Exempt: TI defines "RoHS Exempt" to mean products that contain lead but are compliant with EU RoHS pursuant to a specific EU RoHS exemption.

Green: TI defines "Green" to mean the content of Chlorine (Cl) and Bromine (Br) based flame retardants meet JS709B low halogen requirements of <=1000ppm threshold. Antimony trioxide based flame retardants must also meet the <=1000ppm threshold requirement.

(3) MSL, Peak Temp. - The Moisture Sensitivity Level rating according to the JEDEC industry standard classifications, and peak solder temperature.

(4) There may be additional marking, which relates to the logo, the lot trace code information, or the environmental category on the device.

(5) Multiple Device Markings will be inside parentheses. Only one Device Marking contained in parentheses and separated by a "~" will appear on a device. If a line is indented then it is a continuation of the previous line and the two combined represent the entire Device Marking for that device.

(6) Lead finish/Ball material - Orderable Devices may have multiple material finish options. Finish options are separated by a vertical ruled line. Lead finish/Ball material values may wrap to two lines if the finish value exceeds the maximum column width.

Important Information and Disclaimer:The information provided on this page represents TI's knowledge and belief as of the date that it is provided. TI bases its knowledge and belief on information provided by third parties, and makes no representation or warranty as to the accuracy of such information. Efforts are underway to better integrate information from third parties. TI has taken and continues to take reasonable steps to provide representative and accurate information but may not have conducted destructive testing or chemical analysis on incoming materials and chemicals. TI and TI suppliers consider certain information to be proprietary, and thus CAS numbers and other limited information may not be available for release.

In no event shall TI's liability arising out of such information exceed the total purchase price of the TI part(s) at issue in this document sold by TI to Customer on an annual basis.



D0014A

PACKAGE OUTLINE

SOIC - 1.75 mm max height

SMALL OUTLINE INTEGRATED CIRCUIT



4220718/A 09/2016

NOTES:

1. All linear dimensions are in millimeters. Dimensions in parenthesis are for reference only. Dimensioning and tolerancing per ASME Y14.5M.
2. This drawing is subject to change without notice.
3. This dimension does not include mold flash, protrusions, or gate burrs. Mold flash, protrusions, or gate burrs shall not exceed 0.15 mm, per side.
4. This dimension does not include interlead flash. Interlead flash shall not exceed 0.43 mm, per side.
5. Reference JEDEC registration MS-012, variation AB.

EXAMPLE BOARD LAYOUT

D0014A

SOIC - 1.75 mm max height

SMALL OUTLINE INTEGRATED CIRCUIT



LAND PATTERN EXAMPLE
SCALE:8X



SOLDER MASK DETAILS

4220718/A 09/2016

NOTES: (continued)

- 6. Publication IPC-7351 may have alternate designs.
- 7. Solder mask tolerances between and around signal pads can vary based on board fabrication site.

EXAMPLE STENCIL DESIGN

D0014A

SOIC - 1.75 mm max height

SMALL OUTLINE INTEGRATED CIRCUIT



SOLDER PASTE EXAMPLE
BASED ON 0.125 mm THICK STENCIL
SCALE:8X

4220718/A 09/2016

NOTES: (continued)

8. Laser cutting apertures with trapezoidal walls and rounded corners may offer better paste release. IPC-7525 may have alternate design recommendations.
9. Board assembly site may have different recommendations for stencil design.

PW0014A

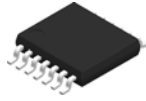

PACKAGE OUTLINE
TSSOP - 1.2 mm max height

SMALL OUTLINE PACKAGE



4220202/B 12/2023

NOTES:

1. All linear dimensions are in millimeters. Any dimensions in parenthesis are for reference only. Dimensioning and tolerancing per ASME Y14.5M.
2. This drawing is subject to change without notice.
3. This dimension does not include mold flash, protrusions, or gate burrs. Mold flash, protrusions, or gate burrs shall not exceed 0.15 mm per side.
4. This dimension does not include interlead flash. Interlead flash shall not exceed 0.25 mm per side.
5. Reference JEDEC registration MO-153.

EXAMPLE BOARD LAYOUT

PW0014A

TSSOP - 1.2 mm max height

SMALL OUTLINE PACKAGE



LAND PATTERN EXAMPLE
EXPOSED METAL SHOWN
SCALE: 10X



4220202/B 12/2023

NOTES: (continued)

- 6. Publication IPC-7351 may have alternate designs.
- 7. Solder mask tolerances between and around signal pads can vary based on board fabrication site.

EXAMPLE STENCIL DESIGN

PW0014A

TSSOP - 1.2 mm max height

SMALL OUTLINE PACKAGE



SOLDER PASTE EXAMPLE
BASED ON 0.125 mm THICK STENCIL
SCALE: 10X

4220202/B 12/2023

NOTES: (continued)

8. Laser cutting apertures with trapezoidal walls and rounded corners may offer better paste release. IPC-7525 may have alternate design recommendations.
9. Board assembly site may have different recommendations for stencil design.

重要なお知らせと免責事項

TI は、技術データと信頼性データ(データシートを含みます)、設計リソース(リファレンス・デザインを含みます)、アプリケーションや設計に関する各種アドバイス、Web ツール、安全性情報、その他のリソースを、欠陥が存在する可能性のある「現状のまま」提供しており、商品性および特定目的に対する適合性の黙示保証、第三者の知的財産権の非侵害保証を含むいかなる保証も、明示的または黙示的にかかわらず拒否します。

これらのリソースは、TI 製品を使用する設計の経験を積んだ開発者への提供を意図したものです。(1) お客様のアプリケーションに適した TI 製品の選定、(2) お客様のアプリケーションの設計、検証、試験、(3) お客様のアプリケーションに該当する各種規格や、その他のあらゆる安全性、セキュリティ、規制、または他の要件への確実な適合に関する責任を、お客様のみが単独で負うものとし、

上記の各種リソースは、予告なく変更される可能性があります。これらのリソースは、リソースで説明されている TI 製品を使用するアプリケーションの開発の目的でのみ、TI はその使用をお客様に許諾します。これらのリソースに関して、他の目的で複製することや掲載することは禁止されています。TI や第三者の知的財産権のライセンスが付与されている訳ではありません。お客様は、これらのリソースを自身で使用した結果発生するあらゆる申し立て、損害、費用、損失、責任について、TI およびその代理人を完全に補償するものとし、TI は一切の責任を拒否します。

TI の製品は、[TI の販売条件](#)、または [ti.com](#) やかかる TI 製品の関連資料などのいずれかを通じて提供する適用可能な条項の下で提供されています。TI がこれらのリソースを提供することは、適用される TI の保証または他の保証の放棄の拡大や変更を意味するものではありません。

お客様がいかなる追加条項または代替条項を提案した場合でも、TI はそれらに異議を唱え、拒否します。

郵送先住所 : Texas Instruments, Post Office Box 655303, Dallas, Texas 75265
Copyright © 2024, Texas Instruments Incorporated