

# SN74LV8T541-Q1 車載用 3 ステート出力、ロジックレベルシフタ搭載、オクタルバッファ/ドライバ

## 1 特長

- 車載アプリケーション用に AEC-Q100 認定済み:
  - デバイス温度グレード 1:  $-40^{\circ}\text{C} \sim +125^{\circ}\text{C}$
  - デバイス HBM ESD 分類レベル 2
  - デバイス CDM ESD 分類レベル C4B
- 幅広い動作範囲: 1.65V ~ 5.5V
- 5.5V 耐圧入力ピン
- 単一電源電圧トランスレータ (「LVxT 拡張入力電圧」を参照):
  - 昇圧変換:
    - 1.2V から 1.8V
    - 1.5V から 2.5V
    - 1.8V から 3.3V
    - 3.3V から 5.0V
  - 降圧変換:
    - 5.0V、3.3V、2.5V から 1.8V
    - 5.0V、3.3V から 2.5V
    - 5.0V から 3.3V
- 5V または 3.3V の  $V_{CC}$  で最大 150Mbps
- 標準機能ピン配置をサポート
- JESD 17 準拠で 250mA 超のラッチアップ性能

## 2 アプリケーション

- デジタル サイネージ
- インジケータ LED の制御
- マイクロコントローラの出力数増加

## 3 概要

SN74LV8T541-Q1 は 3 ステート出力を備えた 8 個のバッファを搭載しています。アクティブ Low の出力イネーブルピン ( $\overline{OE1}$ 、 $\overline{OE2}$ ) は 8 つのチャンネルをすべて制御し、この両方が Low のときのみ出力がアクティブになるよう構成されています。

入力は、スレッシュホールドを低減した回路を使用して設計されており、電源電圧が入力電圧より高い場合の昇圧変換をサポートします。また、5V 許容の入力ピンにより、入力電圧が電源電圧より高い場合の降圧変換が可能です。出力レベルは常に電源電圧 ( $V_{CC}$ ) を基準としており、1.8V、2.5V、3.3V、5V の CMOS レベルをサポートしています。

### パッケージ情報

部品番号	パッケージ (1)	パッケージサイズ (2)	本体サイズ (公称) (3)
SN74LV8T541-Q1	PW (TSSOP, 20)	6.5mm × 6.4mm	6.5mm × 4.4mm

- 詳細については、[セクション 13](#) を参照してください。
- パッケージサイズ (長さ×幅) は公称値であり、該当する場合はピンも含まれます。
- 本体サイズ (長さ×幅) は公称値であり、ピンは含まれません。

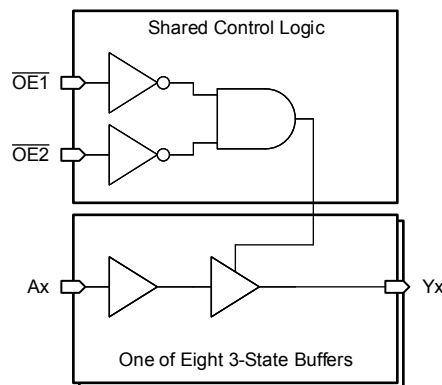

概略論理図 (正論理)



## Table of Contents

<b>1 特長</b> .....	<b>1</b>	8.3 Clamp Diode Structure.....	<b>11</b>
<b>2 アプリケーション</b> .....	<b>1</b>	<b>9 Device Functional Modes</b> .....	<b>12</b>
<b>3 概要</b> .....	<b>1</b>	<b>10 Application and Implementation</b> .....	<b>13</b>
<b>4 Pin Configuration and Functions</b> .....	<b>3</b>	10.1 Application Information.....	13
<b>5 Specifications</b> .....	<b>4</b>	10.2 Typical Application.....	13
5.1 Absolute Maximum Ratings.....	4	10.3 Power Supply Recommendations.....	15
5.2 ESD Ratings.....	4	10.4 Layout.....	15
5.3 Recommended Operating Conditions.....	4	<b>11 Device and Documentation Support</b> .....	<b>17</b>
5.4 Thermal Information.....	5	11.1 Documentation Support.....	17
5.5 Electrical Characteristics.....	5	11.2 ドキュメントの更新通知を受け取る方法.....	17
5.6 Switching Characteristics.....	6	11.3 サポート・リソース.....	17
5.7 Typical Characteristics.....	7	11.4 Trademarks.....	17
<b>6 Parameter Measurement Information</b> .....	<b>9</b>	11.5 静電気放電に関する注意事項.....	17
<b>7 Detailed Description</b> .....	<b>10</b>	11.6 用語集.....	17
7.1 Overview.....	10	<b>12 Revision History</b> .....	<b>17</b>
7.2 Functional Block Diagram.....	10	<b>13 Mechanical, Packaging, and Orderable Information</b> .....	<b>17</b>
<b>8 Feature Description</b> .....	<b>10</b>	13.1 Tape and Reel Information.....	18
8.1 Balanced CMOS 3-State Outputs.....	10	13.2 Mechanical Data.....	20
8.2 LVxT Enhanced Input Voltage.....	10		

## 4 Pin Configuration and Functions



図 4-1. PW Package, 20-Pin TSSOP (Top View)

表 4-1. Pin Functions

PIN		TYPE <sup>(1)</sup>	DESCRIPTION
NAME	NO.		
OE1	1	I	Output enable input 1, active low
A1	2	I	Input for channel 1
A2	3	I	Input for channel 2
A3	4	I	Input for channel 3
A4	5	I	Input for channel 4
A5	6	I	Input for channel 5
A6	7	I	Input for channel 6
A7	8	I	Input for channel 7
A8	9	I	Input for channel 8
GND	10	G	Ground
Y8	11	O	Output for channel 8
Y7	12	O	Output for channel 7
Y6	13	O	Output for channel 6
Y5	14	O	Output for channel 5
Y4	15	O	Output for channel 4
Y3	16	O	Output for channel 3
Y2	17	O	Output for channel 2
Y1	18	O	Output for channel 1
OE2	19	I	Output enable input 2, active low
V <sub>CC</sub>	20	P	Positive supply

(1) I = Input, O = Output, I/O = Input or Output, G = Ground, P = Power

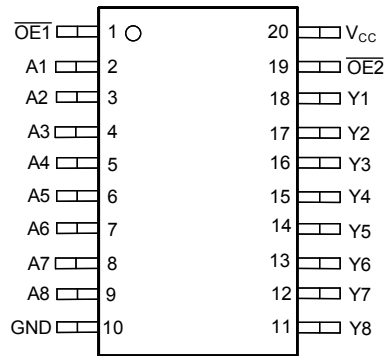
## 5 Specifications

### 5.1 Absolute Maximum Ratings

over operating free-air temperature range (unless otherwise noted)<sup>(1)</sup>

			MIN	MAX	UNIT
$V_{CC}$	Supply voltage range		-0.5	7	V
$V_I$	Input voltage range <sup>(2)</sup>		-0.5	7	V
$V_O$	Voltage range applied to any output in the high-impedance or power-off state <sup>(2)</sup>		-0.5	7	V
$V_O$	Output voltage range <sup>(2)</sup>		-0.5	$V_{CC} + 0.5$	V
$I_{IK}$	Input clamp current	$V_I < -0.5V$		-20	mA
$I_{OK}$	Output clamp current	$V_O < -0.5V$ or $V_O > V_{CC} + 0.5V$		±20	mA
$I_O$	Continuous output current	$V_O = 0$ to $V_{CC}$		±25	mA
	Continuous output current through $V_{CC}$ or GND			±75	mA
$T_{stg}$	Storage temperature		-65	150	°C

- (1) Operation outside the *Absolute Maximum Ratings* may cause permanent device damage. Absolute maximum ratings do not imply functional operation of the device at these or any other conditions beyond those listed under *Recommended Operating Conditions*. If briefly operating outside the *Recommended Operating Conditions* but within the *Absolute Maximum Ratings*, the device may not sustain damage, but it may not be fully functional. Operating the device in this manner may affect device reliability, functionality, performance, and shorten the device lifetime.
- (2) The input and output voltage ratings may be exceeded if the input and output current ratings are observed.

### 5.2 ESD Ratings

			VALUE	UNIT
$V_{(ESD)}$	Electrostatic discharge	Human body model (HBM), per AEC Q100-002 HBM ESD Classification Level 2 <sup>(1)</sup>	±2000	V
		Charged device model (CDM), per AEC Q100-011 CDM ESD Classification Level C4B	±1000	

- (1) AEC Q100-002 indicate that HBM stressing shall be in accordance with the ANSI/ESDA/JEDEC JS-001 specification.

### 5.3 Recommended Operating Conditions

over operating free-air temperature range (unless otherwise noted)

Specifications	Description	Condition	MIN	MAX	UNIT
$V_{CC}$	Supply voltage		1.65	5.5	V
$V_I$	Input voltage		0	5.5	V
$V_O$	Output voltage		0	$V_{CC}$	V
$V_{IH}$	High-level input voltage	$V_{CC} = 1.65V$ to $2V$	1.1		V
		$V_{CC} = 2.25V$ to $2.75V$	1.28		
		$V_{CC} = 3V$ to $3.6V$	1.45		
		$V_{CC} = 4.5V$ to $5.5V$	2		
$V_{IL}$	Low-Level input voltage	$V_{CC} = 1.65V$ to $2V$		0.51	V
		$V_{CC} = 2.25V$ to $2.75V$		0.65	
		$V_{CC} = 3V$ to $3.6V$		0.75	
		$V_{CC} = 4.5V$ to $5.5V$		0.8	
$I_O$	Output current	$V_{CC} = 1.6V$ to $2V$		±8	mA
		$V_{CC} = 2.25V$ to $2.75V$		±15	
		$V_{CC} = 3.3V$ to $5.0V$		±25	
$\Delta t/\Delta v$	Input transition rise or fall rate	$V_{CC} = 1.6V$ to $5.0V$		20	ns/V
$T_A$	Operating free-air temperature		-40	125	°C

## 5.4 Thermal Information

THERMAL METRIC <sup>(1)</sup>		PW (TSSOP)	UNIT
		20 PINS	
R <sub>θJA</sub>	Junction-to-ambient thermal resistance	135.9	°C/W
R <sub>θJC(top)</sub>	Junction-to-case (top) thermal resistance	70.3	°C/W
R <sub>θJB</sub>	Junction-to-board thermal resistance	81.3	°C/W
Ψ <sub>JT</sub>	Junction-to-top characterization parameter	22.5	°C/W
Y <sub>JB</sub>	Junction-to-board characterization parameter	80.8	°C/W
R <sub>θJC(bot)</sub>	Junction-to-case (bottom) thermal resistance	N/A	°C/W

(1) For more information about traditional and new thermal metrics, see the [Semiconductor and IC Package Thermal Metrics](#) application report.

## 5.5 Electrical Characteristics

over operating free-air temperature range (unless otherwise noted)

PARAMETER	TEST CONDITIONS	V <sub>CC</sub>	T <sub>A</sub> = 25°C			-40°C to 125°C			UNIT
			MIN	TYP	MAX	MIN	TYP	MAX	
V <sub>OH</sub>	I <sub>OH</sub> = -50μA	1.65V to 5.5V	V <sub>CC</sub> -0.1			V <sub>CC</sub> -0.1			V
	I <sub>OH</sub> = -2mA	1.65V to 2V	1.28	1.7 <sup>(1)</sup>		1.21			
	I <sub>OH</sub> = -3mA	2.25V to 2.75V	2	2.4 <sup>(1)</sup>		1.93			
	I <sub>OH</sub> = -5.5mA	3V to 3.6V	2.6	3.08 <sup>(1)</sup>		2.49			
	I <sub>OH</sub> = -8mA	4.5V to 5.5V	4.1	4.65 <sup>(1)</sup>		3.95			
V <sub>OL</sub>	I <sub>OL</sub> = 50 μA	1.65V to 5.5V			0.1			0.1	V
	I <sub>OL</sub> = 2mA	1.65V to 2V	0.1 <sup>(1)</sup>		0.2			0.25	
	I <sub>OL</sub> = 3mA	2.25V to 2.75V		0.15 <sup>(1)</sup>	0.17			0.2	
	I <sub>OL</sub> = 5.5mA	3V to 3.6V		0.2 <sup>(1)</sup>	0.23			0.25	
	I <sub>OL</sub> = 8mA	4.5V to 5.5V		0.3 <sup>(1)</sup>	0.3			0.35	
I <sub>I</sub>	V <sub>I</sub> = 0V or V <sub>CC</sub>	0V to 5.5V			±0.1			±1	μA
I <sub>CC</sub>	V <sub>I</sub> = 0V or V <sub>CC</sub> , I <sub>O</sub> = 0; open on loading	1.65V to 5.5V			2			20	μA
ΔI <sub>CC</sub>	One input at 0.3V or 3.4V, other inputs at 0 or V <sub>CC</sub> , I <sub>O</sub> = 0	5.5V			1.35			1.5	mA
	One input at 0.3V or 1.1V, other inputs at 0 or V <sub>CC</sub> , I <sub>O</sub> = 0	1.8V			10			20	μA
I <sub>OZ</sub>	V <sub>O</sub> = V <sub>CC</sub> or GND and V <sub>CC</sub> = 5.5V	5.5V			±0.25			±2.5	μA
C <sub>I</sub>	V <sub>I</sub> = V <sub>CC</sub> or GND	5V			4	10		10	pF
C <sub>O</sub>	V <sub>O</sub> = V <sub>CC</sub> or GND	5V			5				pF
C <sub>PD</sub>	No load, F = 1MHz	5V			17				pF

(1) Typical value at nearest nominal voltage (1.8V, 2.5V, 3.3V, and 5V)

## 5.6 Switching Characteristics

Over operating free-air temperature range; typical values measured at  $T_A = 25^\circ\text{C}$  (unless otherwise noted). See *Parameter Measurement Information*.

PARAMETER	FROM (INPUT)	TO (OUTPUT)	LOAD CAPACITANCE	$V_{CC}$	$T_A = 25^\circ\text{C}$			$-40^\circ\text{C to } 125^\circ\text{C}$			UNIT
					MIN	TYP	MAX	MIN	TYP	MAX	
$t_{PLH}$	A	Y	$C_L = 15\text{pF}$	1.8V	5.3	12.1	4.8	13.4	ns		
$t_{PHL}$					6.7	15.8	5.9	17.4	ns		
$t_{PZH}$	$\overline{\text{OE}}$	Y	$C_L = 15\text{pF}$	1.8V	9	20.5	7.9	23	ns		
$t_{PZL}$					8.1	19.3	7.1	21.4	ns		
$t_{PHZ}$	$\overline{\text{OE}}$	Y	$C_L = 15\text{pF}$	1.8V	7	13.2	6.3	15	ns		
$t_{PLZ}$					6.7	11.7	6.3	12.9	ns		
$t_{PLH}$	A	Y	$C_L = 50\text{pF}$	1.8V	7.3	16.4	6.5	18.2	ns		
$t_{PHL}$					8.4	19.6	7.5	21.7	ns		
$t_{PZH}$	$\overline{\text{OE}}$	Y	$C_L = 50\text{pF}$	1.8V	11.4	25.1	9.9	28.2	ns		
$t_{PZL}$					10.1	23.5	9	26	ns		
$t_{PHZ}$	$\overline{\text{OE}}$	Y	$C_L = 50\text{pF}$	1.8V	12.8	20.5	12	22.5	ns		
$t_{PLZ}$					12.6	19	12	20.3	ns		
$t_{sk(o)}$			$C_L = 50\text{pF}$	1.8V		0.3		0.3	ns		
$t_{PLH}$	A	Y	$C_L = 15\text{pF}$	2.5V	3.9	7.7	3.4	8.7	ns		
$t_{PHL}$					4.9	9.8	4.3	11.2	ns		
$t_{PZH}$	$\overline{\text{OE}}$	Y	$C_L = 15\text{pF}$	2.5V	6.6	12.6	5.7	14.7	ns		
$t_{PZL}$					5.8	11.6	5	13.5	ns		
$t_{PHZ}$	$\overline{\text{OE}}$	Y	$C_L = 15\text{pF}$	2.5V	5	8.5	4.4	9.8	ns		
$t_{PLZ}$					5.1	7.9	4.6	8.8	ns		
$t_{PLH}$	A	Y	$C_L = 50\text{pF}$	2.5V	5.3	10.6	4.7	12	ns		
$t_{PHL}$					6.2	12.5	5.5	14.2	ns		
$t_{PZH}$	$\overline{\text{OE}}$	Y	$C_L = 50\text{pF}$	2.5V	8.4	15.9	7.3	18.3	ns		
$t_{PZL}$					7.5	14.7	6.7	16.9	ns		
$t_{PHZ}$	$\overline{\text{OE}}$	Y	$C_L = 50\text{pF}$	2.5V	8.8	13.4	8.1	14.8	ns		
$t_{PLZ}$					9	12.8	8.5	13.8	ns		
$t_{sk(o)}$			$C_L = 50\text{pF}$	2.5V		0.3		0.3	ns		
$t_{PLH}$	A	Y	$C_L = 15\text{pF}$	3.3V	3.4	6.3	3	7.3	ns		
$t_{PHL}$					4.2	8.1	3.7	9.3	ns		
$t_{PZH}$	$\overline{\text{OE}}$	Y	$C_L = 15\text{pF}$	3.3V	5.7	10.3	5	11.9	ns		
$t_{PZL}$					5	9.5	4.4	11	ns		
$t_{PHZ}$	$\overline{\text{OE}}$	Y	$C_L = 15\text{pF}$	3.3V	3.7	6.7	3.2	7.9	ns		
$t_{PLZ}$					4.4	6.6	4.1	7.4	ns		
$t_{PLH}$	A	Y	$C_L = 50\text{pF}$	3.3V	4.6	8.8	4	10	ns		
$t_{PHL}$					5.5	10.4	4.9	11.9	ns		
$t_{PZH}$	$\overline{\text{OE}}$	Y	$C_L = 50\text{pF}$	3.3V	7.4	13.1	6.4	15.1	ns		
$t_{PZL}$					6.7	12.1	6	14	ns		
$t_{PHZ}$	$\overline{\text{OE}}$	Y	$C_L = 50\text{pF}$	3.3V	7	10.5	6.5	11.7	ns		
$t_{PLZ}$					7.6	10.6	7.3	11.4	ns		
$t_{sk(o)}$			$C_L = 50\text{pF}$	3.3V		0.2		0.2	ns		
$t_{PLH}$	A	Y	$C_L = 15\text{pF}$	5V	3.1	5.4	2.9	6.1	ns		
$t_{PHL}$					3.1	5.5	2.8	6.3	ns		

ADVANCE INFORMATION

## 5.6 Switching Characteristics (続き)

Over operating free-air temperature range; typical values measured at  $T_A = 25^\circ\text{C}$  (unless otherwise noted). See *Parameter Measurement Information*.

PARAMETER	FROM (INPUT)	TO (OUTPUT)	LOAD CAPACITANCE	$V_{CC}$	$T_A = 25^\circ\text{C}$			$-40^\circ\text{C to } 125^\circ\text{C}$			UNIT
					MIN	TYP	MAX	MIN	TYP	MAX	
$t_{PZH}$	$\overline{OE}$	Y	$C_L = 15\text{pF}$	5V	4.3	7.1	3.7	8.4	ns		
$t_{PZL}$					3.6	6.4	3.2	7.6	ns		
$t_{PHZ}$	$\overline{OE}$	Y	$C_L = 15\text{pF}$	5V	3.1	5	2.7	5.8	ns		
$t_{PLZ}$					4.3	6	4	6.5	ns		
$t_{PLH}$	A	Y	$C_L = 50\text{pF}$	5V	4.1	7.2	3.7	8.1	ns		
$t_{PHL}$					4.2	7.2	3.8	8.4	ns		
$t_{PZH}$	$\overline{OE}$	Y	$C_L = 50\text{pF}$	5V	5.6	9.4	4.9	10.9	ns		
$t_{PZL}$					5	8.6	4.5	9.9	ns		
$t_{PHZ}$	$\overline{OE}$	Y	$C_L = 50\text{pF}$	5V	4.9	7.3	4.6	8.1	ns		
$t_{PLZ}$					6.3	8.4	6.1	8.9	ns		
$t_{sk(o)}$			$C_L = 50\text{pF}$	5V		0.3		0.3	ns		

## 5.7 Typical Characteristics

$T_A = 25^\circ\text{C}$  (unless otherwise noted)

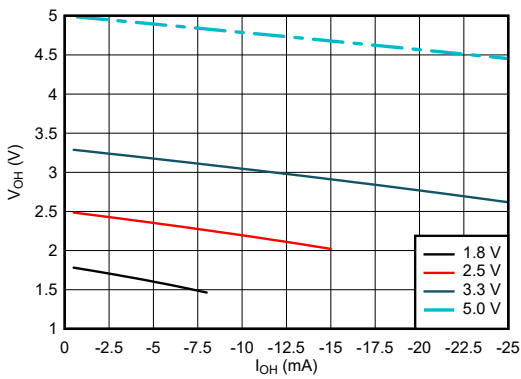

5-1. Output Voltage vs Current in HIGH State

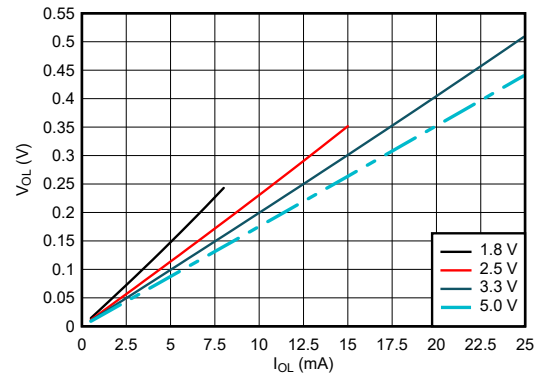

5-2. Output Voltage vs Current in LOW State

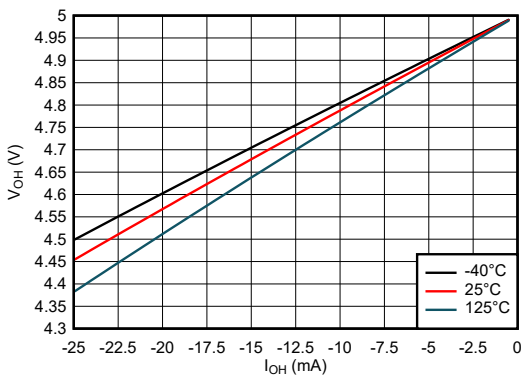

5-3. Output Voltage vs Current in HIGH State; 5-V Supply

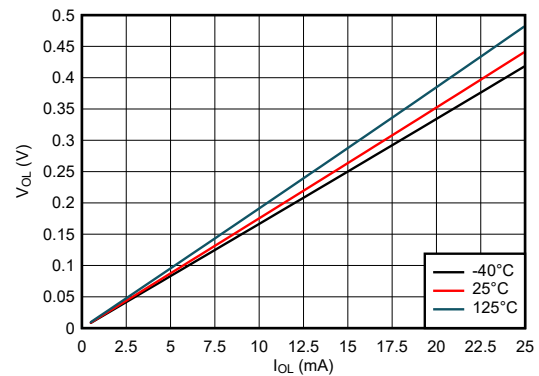

5-4. Output Voltage vs Current in LOW State; 5-V Supply

## 5.7 Typical Characteristics (continued)

T<sub>A</sub> = 25°C (unless otherwise noted)

ADVANCE INFORMATION



图 5-5. Output Voltage vs Current in HIGH State; 3.3-V Supply



图 5-6. Output Voltage vs Current in LOW State; 3.3-V Supply

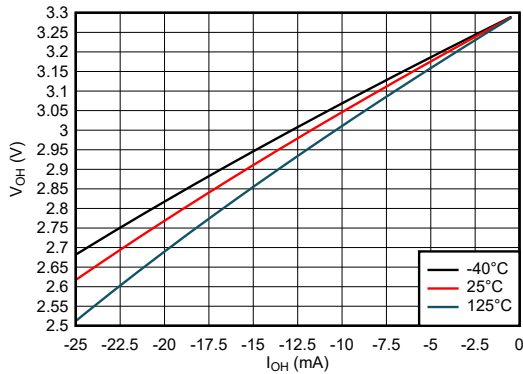

图 5-7. Output Voltage vs Current in HIGH State; 2.5-V Supply

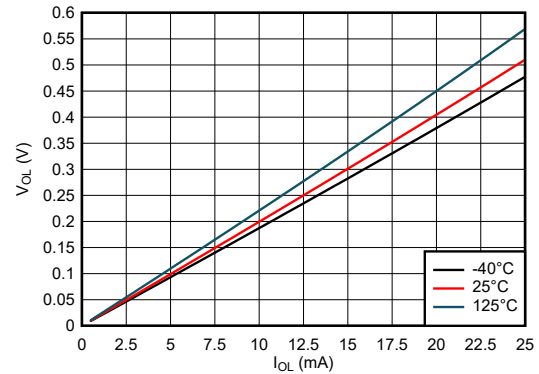

图 5-8. Output Voltage vs Current in LOW State; 2.5-V Supply

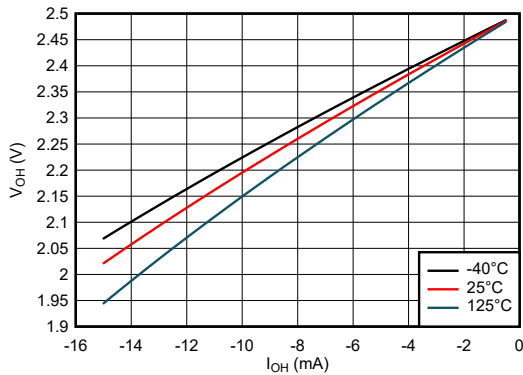

图 5-9. Output Voltage vs Current in HIGH State; 1.8-V Supply

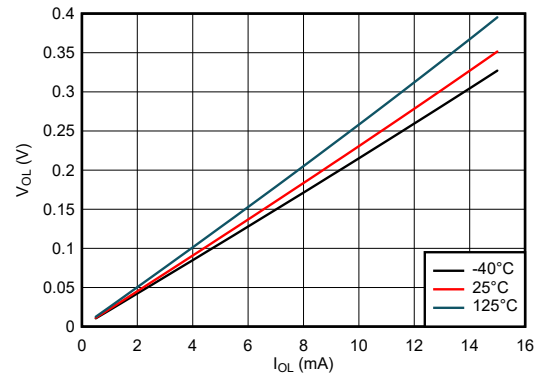

图 5-10. Output Voltage vs Current in LOW State; 1.8-V Supply

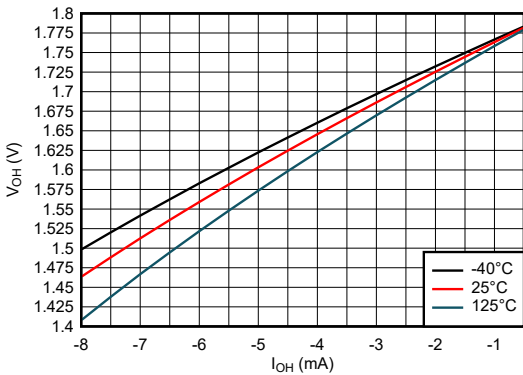

## 6 Parameter Measurement Information

Phase relationships between waveforms were chosen arbitrarily for the examples listed in the following table. All input pulses are supplied by generators having the following characteristics: PRR  $\leq$  1MHz,  $Z_O = 50\Omega$ ,  $t_f < 2.5\text{ns}$ .

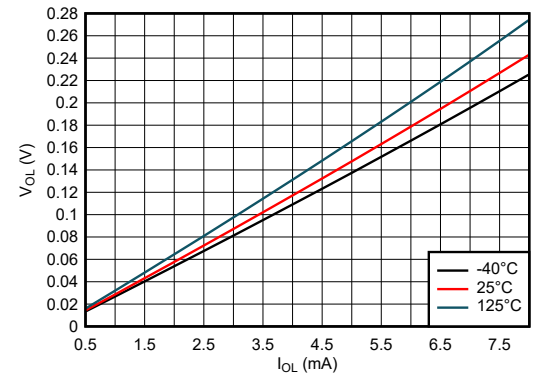
The outputs are measured individually with one input transition per measurement.

TEST	S1	S2	$R_L$	$C_L$	$\Delta V$	$V_{CC}$
$t_{PLH}$ , $t_{PHL}$	OPEN	OPEN	—	15pF, 50pF	—	ALL
$t_{PLZ}$ , $t_{PZL}$	CLOSED	OPEN	1k $\Omega$	15pF, 50pF	0.15V	$\leq 2.5\text{V}$
$t_{PHZ}$ , $t_{PZH}$	OPEN	CLOSED	1k $\Omega$	15pF, 50pF	0.15V	$\leq 2.5\text{V}$
$t_{PLZ}$ , $t_{PZL}$	CLOSED	OPEN	1k $\Omega$	15pF, 50pF	0.3V	$> 2.5\text{V}$
$t_{PHZ}$ , $t_{PZH}$	OPEN	CLOSED	1k $\Omega$	15pF, 50pF	0.3V	$> 2.5\text{V}$

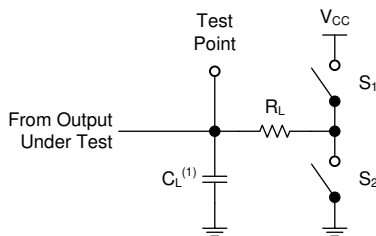

(1)  $C_L$  includes probe and test-fixture capacitance.

6-1. Load Circuit for 3-State Outputs

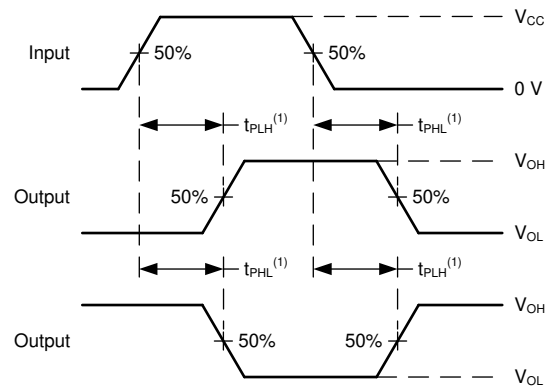

(1) The greater between  $t_{PLH}$  and  $t_{PHL}$  is the same as  $t_{pd}$ .

6-2. Voltage Waveforms Propagation Delays

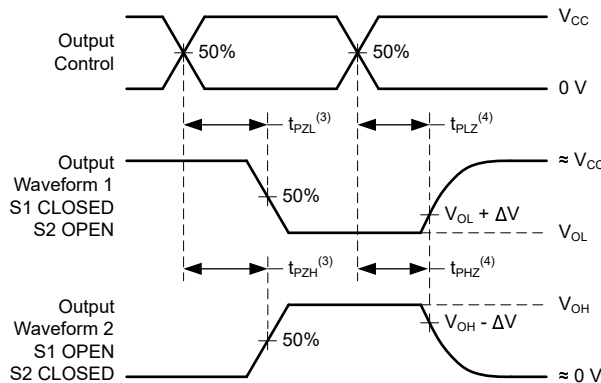

(3) The greater between  $t_{PZL}$  and  $t_{PZH}$  is the same as  $t_{en}$ .

(4) The greater between  $t_{PLZ}$  and  $t_{PHZ}$  is the same as  $t_{dis}$ .

6-3. Voltage Waveforms Propagation Delays

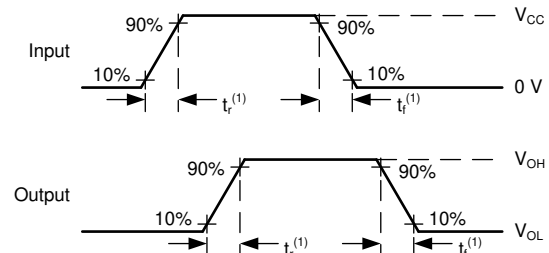

(1) The greater between  $t_r$  and  $t_f$  is the same as  $t_t$ .

6-4. Voltage Waveforms, Input and Output Transition Times

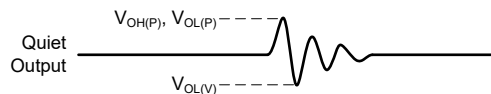

Noise values measured with all other outputs simultaneously switching.

6-5. Voltage Waveforms, Noise

## 7 Detailed Description

### 7.1 Overview

The SN74LV8T541-Q1 contains eight buffers with 3-state outputs. The active low output enable pins ( $\overline{OE1}$  and  $\overline{OE2}$ ) control all eight channels, and are configured so that both must be low for the outputs to be active.

When the outputs are enabled, the outputs are actively driven low or high.

When the outputs are disabled, the outputs are set into the high-impedance state.

### 7.2 Functional Block Diagram

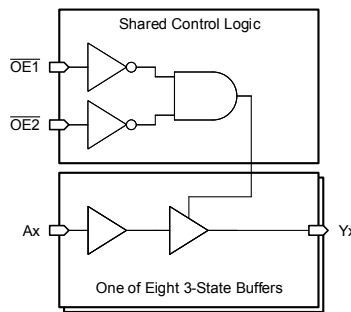

## 8 Feature Description

### 8.1 Balanced CMOS 3-State Outputs

This device includes balanced CMOS 3-state outputs. Driving high, driving low, and high impedance are the three states that these outputs can be in. The term *balanced* indicates that the device can sink and source similar currents. The drive capability of this device may create fast edges into light loads, so routing and load conditions should be considered to prevent ringing. Additionally, the outputs of this device can drive larger currents than the device can sustain without being damaged. It is important for the output power of the device to be limited to avoid damage due to overcurrent. The electrical and thermal limits defined in the *Absolute Maximum Ratings* must be followed at all times.

When placed into the high-impedance state, the output will neither source nor sink current, with the exception of minor leakage current as defined in the *Electrical Characteristics* table. In the high-impedance state, the output voltage is not controlled by the device and is dependent on external factors. If no other drivers are connected to the node, then this is known as a floating node and the voltage is unknown. A pull-up or pull-down resistor can be connected to the output to provide a known voltage at the output while it is in the high-impedance state. The value of the resistor will depend on multiple factors, including parasitic capacitance and power consumption limitations. Typically, a 10k $\Omega$  resistor can be used to meet these requirements.

Unused 3-state CMOS outputs should be left disconnected.

### 8.2 LVxT Enhanced Input Voltage

The SN74LV8T541-Q1 belongs to TI's LVxT family of logic devices with integrated voltage level translation. This family of devices was designed with reduced input voltage thresholds to support up-translation, and inputs tolerant of signals with up to 5.5V levels to support down-translation. For proper functionality, input signals must remain at or above the specified  $V_{IH(MIN)}$  level for a HIGH input state, and at or below the specified  $V_{IL(MAX)}$  for a LOW input state. [Figure 8-1](#) shows the typical  $V_{IH}$  and  $V_{IL}$  levels for the LVxT family of devices, as well as the voltage levels for standard CMOS devices for comparison.

The inputs are high impedance and are typically modeled as a resistor in parallel with the input capacitance given in the *Electrical Characteristics*. The worst case resistance is calculated with the maximum input voltage, given in the *Absolute Maximum Ratings*, and the maximum input leakage current, given in the *Electrical Characteristics*, using Ohm's law ( $R = V \div I$ ).

Input signals must transition between valid logic states quickly, as defined by the input transition rate in the *Recommended Operating Conditions* table. Failing to meet this specification will result in excessive power consumption and could cause oscillations. More details can be found in the [Implications of Slow or Floating CMOS Inputs](#) application report.

Do not leave inputs floating at any time during operation. Unused inputs must be terminated at a valid high or low voltage level. If a system will not be actively driving an input at all times, then a pull-up or pull-down resistor can be added to provide a valid input voltage during these times. The resistor value will depend on multiple factors; however, a 10kΩ resistor is recommended and will typically meet all requirements.



図 8-1. LVxT Input Voltage Levels

### 8.3 Clamp Diode Structure

As 図 8-2 shows, the outputs to this device have both positive and negative clamping diodes, and the inputs to this device have negative clamping diodes only.

**注意**

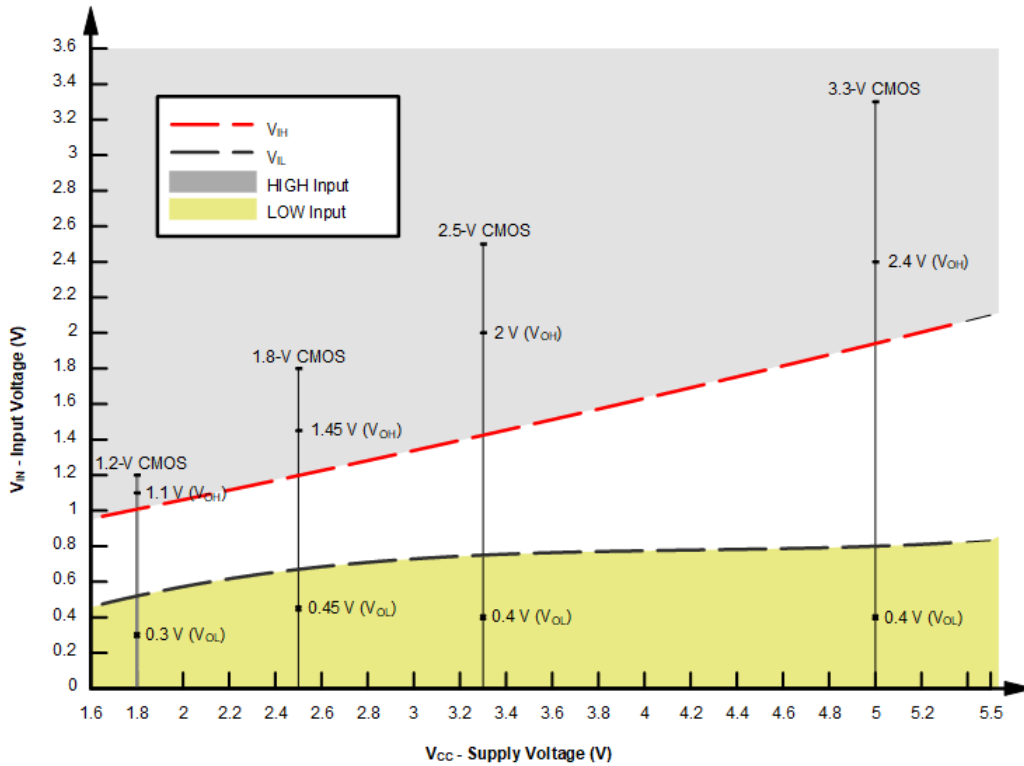
Voltages beyond the values specified in the *Absolute Maximum Ratings* table can cause damage to the device. The input and output voltage ratings may be exceeded if the input and output clamp-current ratings are observed.



図 8-2. Electrical Placement of Clamping Diodes for Each Input and Output

## 9 Device Functional Modes

表 9-1 lists the functional modes of the SN74LV8T541-Q1.

表 9-1. Function Table

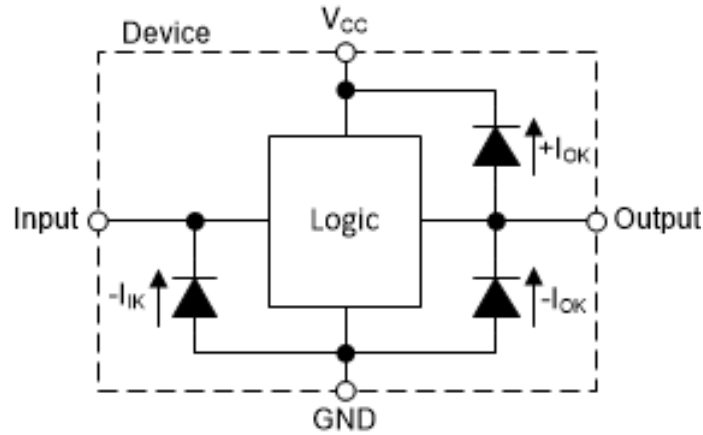
INPUTS <sup>(1)</sup>			OUTPUT <sup>(2)</sup>
OE1	OE2	A	Y
L	L	L	L
L	L	H	H
H	X	X	Z
X	H	X	Z

- (1) L = input low, H = input high, X = don't care  
 (2) L = output low, H = output high, Z = high impedance

## 10 Application and Implementation

### 注

Information in the following applications sections is not part of the TI component specification, and TI does not warrant its accuracy or completeness. TI's customers are responsible for determining suitability of components for their purposes, as well as validating and testing their design implementation to confirm system functionality.

### 10.1 Application Information

The SN74LV8T541-Q1 can be used to drive signals over relatively long traces or transmission lines. A series damping resistor placed in series with the transmitter's output can be used to reduce ringing caused by impedance mismatches between the driver, transmission line, and receiver. The figure in the *Application Curve* section shows the received signal with three separate resistor values. Just a small amount of resistance can make a significant impact on signal integrity in this type of application.

### 10.2 Typical Application

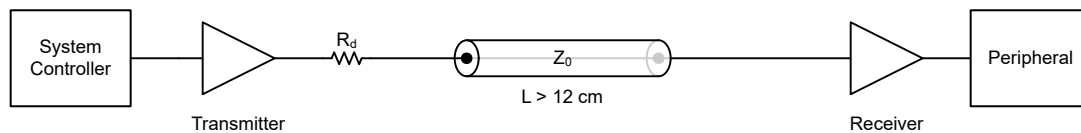

FIG 10-1. Typical Application Block Diagram

#### 10.2.1 Design Requirements

##### 10.2.1.1 Power Considerations

Ensure the desired supply voltage is within the range specified in the *Recommended Operating Conditions*. The supply voltage sets the device's electrical characteristics as described in the *Electrical Characteristics*.

The positive voltage supply must be capable of sourcing current equal to the total current to be sourced by all outputs of the SN74LV8T541-Q1 plus the maximum static supply current,  $I_{CC}$ , listed in the *Electrical Characteristics* and any transient current required for switching. The logic device can only source as much current as is provided by the positive supply source. Ensure the maximum total current through  $V_{CC}$  listed in the *Absolute Maximum Ratings* is not exceeded.

The ground must be capable of sinking current equal to the total current to be sunk by all outputs of the SN74LV8T541-Q1 plus the maximum supply current,  $I_{CC}$ , listed in the *Electrical Characteristics*, and any transient current required for switching. The logic device can only sink as much current as can be sunk into its ground connection. Ensure the maximum total current through GND listed in the *Absolute Maximum Ratings* is not exceeded.

The SN74LV8T541-Q1 can drive a load with a total capacitance less than or equal to 50pF while still meeting all of the data sheet specifications. Larger capacitive loads can be applied; however, it is not recommended to exceed 50pF.

The SN74LV8T541-Q1 can drive a load with total resistance described by  $R_L \geq V_O / I_O$ , with the output voltage and current defined in the *Electrical Characteristics* table with  $V_{OH}$  and  $V_{OL}$ . When outputting in the high state, the output voltage in the equation is defined as the difference between the measured output voltage and the supply voltage at the  $V_{CC}$  pin.

Total power consumption can be calculated using the information provided in [CMOS Power Consumption and Cpd Calculation](#).

Thermal increase can be calculated using the information provided in [Thermal Characteristics of Standard Linear and Logic \(SLL\) Packages and Devices](#).

### 注意

The maximum junction temperature,  $T_{J(max)}$  listed in the *Absolute Maximum Ratings*, is an additional limitation to prevent damage to the device. Do not violate any values listed in the *Absolute Maximum Ratings*. These limits are provided to prevent damage to the device.

#### 10.2.1.2 Input Considerations

Input signals must cross  $V_{IL(max)}$  to be considered a logic LOW, and  $V_{IH(min)}$  to be considered a logic HIGH. Do not exceed the maximum input voltage range found in the *Absolute Maximum Ratings*.

Unused inputs must be terminated to either  $V_{CC}$  or ground. These can be directly terminated if the input is completely unused, or they can be connected with a pull-up or pull-down resistor if the input is to be used sometimes, but not always. A pull-up resistor is used for a default state of HIGH, and a pull-down resistor is used for a default state of LOW. The resistor size is limited by drive current of the controller, leakage current into the SN74LV8T541-Q1, as specified in the *Electrical Characteristics*, and the desired input transition rate. A 10k $\Omega$  resistor value is often used due to these factors.

The SN74LV8T541-Q1 has CMOS inputs and thus requires fast input transitions to operate correctly, as defined in the *Recommended Operating Conditions* table. Slow input transitions can cause oscillations, additional power consumption, and reduction in device reliability.

Refer to the *Feature Description* section for additional information regarding the inputs for this device.

#### 10.2.1.3 Output Considerations

The positive supply voltage is used to produce the output HIGH voltage. Drawing current from the output will decrease the output voltage as specified by the  $V_{OH}$  specification in the *Electrical Characteristics*. The ground voltage is used to produce the output LOW voltage. Sinking current into the output will increase the output voltage as specified by the  $V_{OL}$  specification in the *Electrical Characteristics*.

Push-pull outputs that could be in opposite states, even for a very short time period, should never be connected directly together. This can cause excessive current and damage to the device.

Two channels within the same device with the same input signals can be connected in parallel for additional output drive strength.

Unused outputs can be left floating. Do not connect outputs directly to  $V_{CC}$  or ground.

Refer to *Feature Description* section for additional information regarding the outputs for this device.

#### 10.2.2 Detailed Design Procedure

1. Add a decoupling capacitor from  $V_{CC}$  to GND. The capacitor needs to be placed physically close to the device and electrically close to both the  $V_{CC}$  and GND pins. An example layout is shown in the *Layout* section.
2. Ensure the capacitive load at the output is  $\leq 50$ pF. This is not a hard limit; by design, however, it will optimize performance. This can be accomplished by providing short, appropriately sized traces from the SN74LV8T541-Q1 to one or more of the receiving devices.
3. Ensure the resistive load at the output is larger than  $(V_{CC} / I_{O(max)})\Omega$ . Doing this will prevent the maximum output current from the *Absolute Maximum Ratings* from being violated. Most CMOS inputs have a resistive load measured in M $\Omega$ ; much larger than the minimum calculated previously.
4. Thermal issues are rarely a concern for logic gates; the power consumption and thermal increase, however, can be calculated using the steps provided in the application report, [CMOS Power Consumption and Cpd Calculation](#).

### 10.2.3 Application Curves

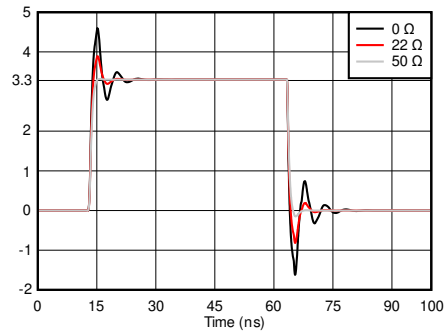

**10-2. Simulated Signal Integrity at the Receiver with Different Damping Resistor ( $R_d$ ) Values**

### 10.3 Power Supply Recommendations

The power supply can be any voltage between the minimum and maximum supply voltage rating located in the *Recommended Operating Conditions*. Each  $V_{CC}$  terminal should have a good bypass capacitor to prevent power disturbance. A  $0.1\mu\text{F}$  capacitor is recommended for this device. It is acceptable to parallel multiple bypass capacitors to reject different frequencies of noise. The  $0.1\mu\text{F}$  and  $1\mu\text{F}$  capacitors are commonly used in parallel. As shown in the following layout example, install the bypass capacitor as close to the power terminal as possible for best results.

### 10.4 Layout

#### 10.4.1 Layout Guidelines

When using multiple-input and multiple-channel logic devices inputs must never be left floating. In many cases, functions or parts of functions of digital logic devices are unused; for example, when only two inputs of a triple-input AND gate are used or only 3 of the 4 buffer gates are used. Such unused input pins must not be left unconnected because the undefined voltages at the outside connections result in undefined operational states. All unused inputs of digital logic devices must be connected to a logic high or logic low voltage, as defined by the input voltage specifications, to prevent them from floating. The logic level that must be applied to any particular unused input depends on the function of the device. Generally, the inputs are tied to GND or  $V_{CC}$ , whichever makes more sense for the logic function or is more convenient.

### 10.4.2 Layout Example



図 10-3. Example Layout for the SN74LV8T541-Q1 in TSSOP

ADVANCE INFORMATION

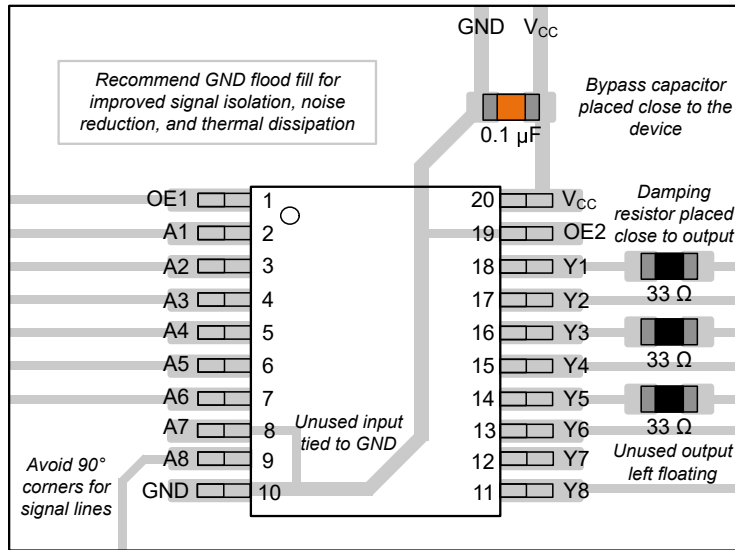

## 11 Device and Documentation Support

TI offers an extensive line of development tools. Tools and software to evaluate the performance of the device, generate code, and develop solutions are listed below.

### 11.1 Documentation Support

#### 11.1.1 Related Documentation

For related documentation, see the following:

- Texas Instruments, [CMOS Power Consumption and  \$C\_{pd}\$  Calculation application report](#)
- Texas Instruments, [Designing With Logic application report](#)
- Texas Instruments, [Thermal Characteristics of Standard Linear and Logic \(SLL\) Packages and Devices application report](#)

### 11.2 ドキュメントの更新通知を受け取る方法

ドキュメントの更新についての通知を受け取るには、[www.tij.co.jp](http://www.tij.co.jp) のデバイス製品フォルダを開いてください。[通知] をクリックして登録すると、変更されたすべての製品情報に関するダイジェストを毎週受け取ることができます。変更の詳細については、改訂されたドキュメントに含まれている改訂履歴をご覧ください。

### 11.3 サポート・リソース

テキサス・インスツルメンツ E2E™ サポート・フォーラムは、エンジニアが検証済みの回答と設計に関するヒントをエキスパートから迅速かつ直接得ることができる場所です。既存の回答を検索したり、独自の質問をしたりすることで、設計に必要な支援を迅速に得ることができます。

リンクされているコンテンツは、各寄稿者により「現状のまま」提供されるものです。これらはテキサス・インスツルメンツの仕様を構成するものではなく、必ずしもテキサス・インスツルメンツの見解を反映したものではありません。テキサス・インスツルメンツの[使用条件](#)を参照してください。

### 11.4 Trademarks

テキサス・インスツルメンツ E2E™ is a trademark of Texas Instruments.  
すべての商標は、それぞれの所有者に帰属します。

### 11.5 静電気放電に関する注意事項



この IC は、ESD によって破損する可能性があります。テキサス・インスツルメンツは、IC を取り扱う際には常に適切な注意を払うことを推奨します。正しい取り扱いおよび設置手順に従わない場合、デバイスを破損するおそれがあります。

ESD による破損は、わずかな性能低下からデバイスの完全な故障まで多岐にわたります。精密な IC の場合、パラメータがわずかに変化するだけで公表されている仕様から外れる可能性があるため、破損が発生しやすくなっています。

### 11.6 用語集

[テキサス・インスツルメンツ用語集](#) この用語集には、用語や略語の一覧および定義が記載されています。

## 12 Revision History

DATE	REVISION	NOTES
March 2024	*	Initial Release

## 13 Mechanical, Packaging, and Orderable Information

The following pages include mechanical, packaging, and orderable information. This information is the most current data available for the designated devices. This data is subject to change without notice and revision of this document. For browser-based versions of this data sheet, refer to the left-hand navigation.

### 13.1 Tape and Reel Information

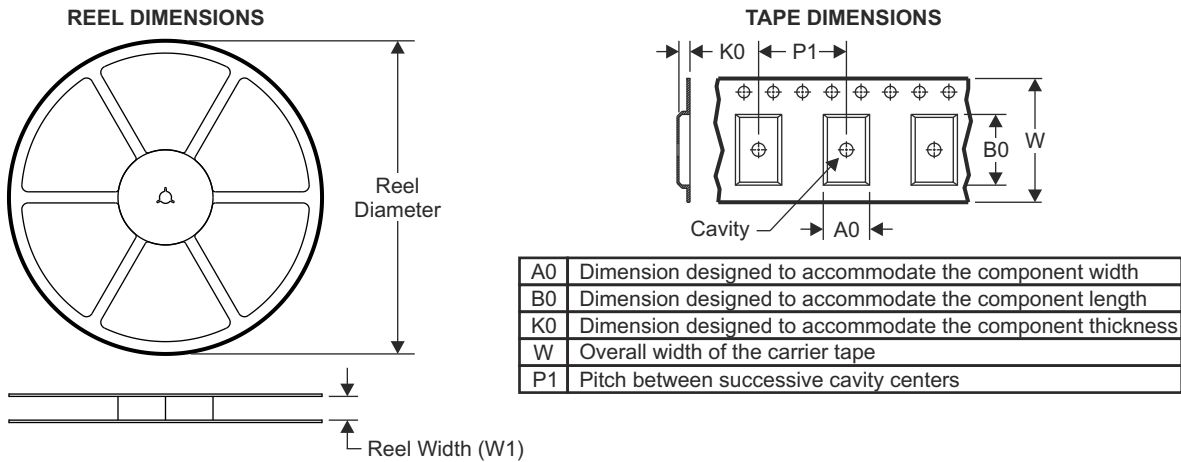

#### QUADRANT ASSIGNMENTS FOR PIN 1 ORIENTATION IN TAPE

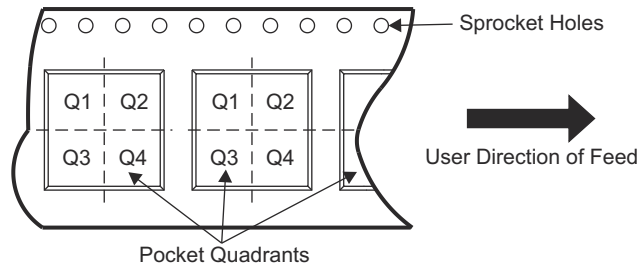

Device	Package Type	Package Drawing	Pins	SPQ	Reel Diameter (mm)	Reel Width W1 (mm)	A0 (mm)	B0 (mm)	K0 (mm)	P1 (mm)	W (mm)	Pin1 Quadrant
P118T541QPWRQ1	TSSOP	PW	20	2000	330.0	16.4	6.95	7.00	1.4	8.0	12.0	Q1

ADVANCE INFORMATION

TAPE AND REEL BOX DIMENSIONS

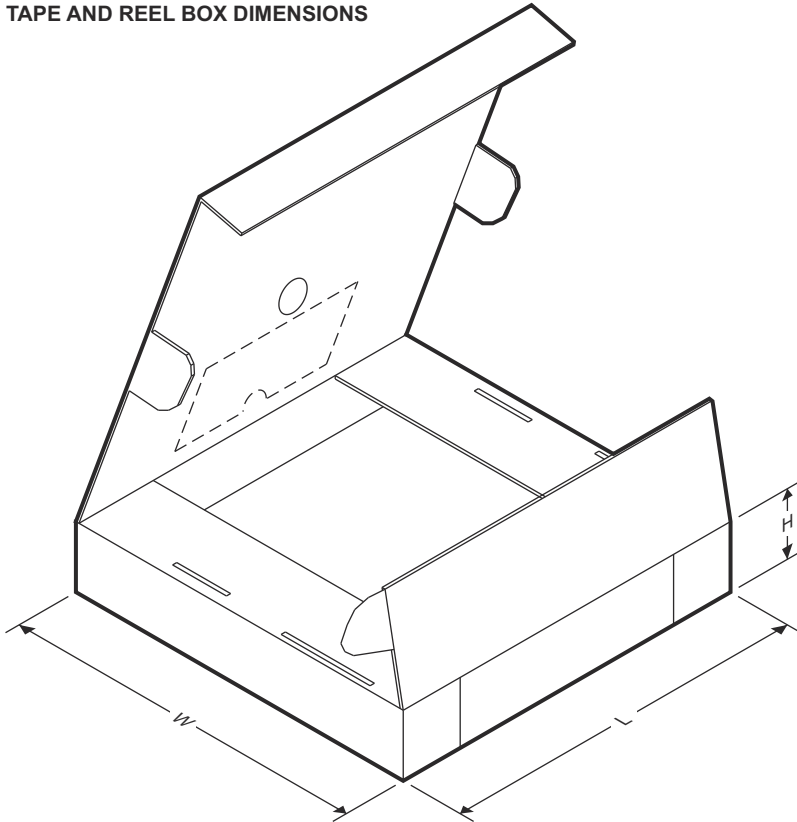

Device	Package Type	Package Drawing	Pins	SPQ	Length (mm)	Width (mm)	Height (mm)
P118T541QPWRQ1	TSSOP	PW	20	2000	367.0	367.0	38.0

ADVANCE INFORMATION

13.2 Mechanical Data

ADVANCE INFORMATION



**PW0020A**

**PACKAGE OUTLINE**  
**TSSOP - 1.2 mm max height**

SMALL OUTLINE PACKAGE

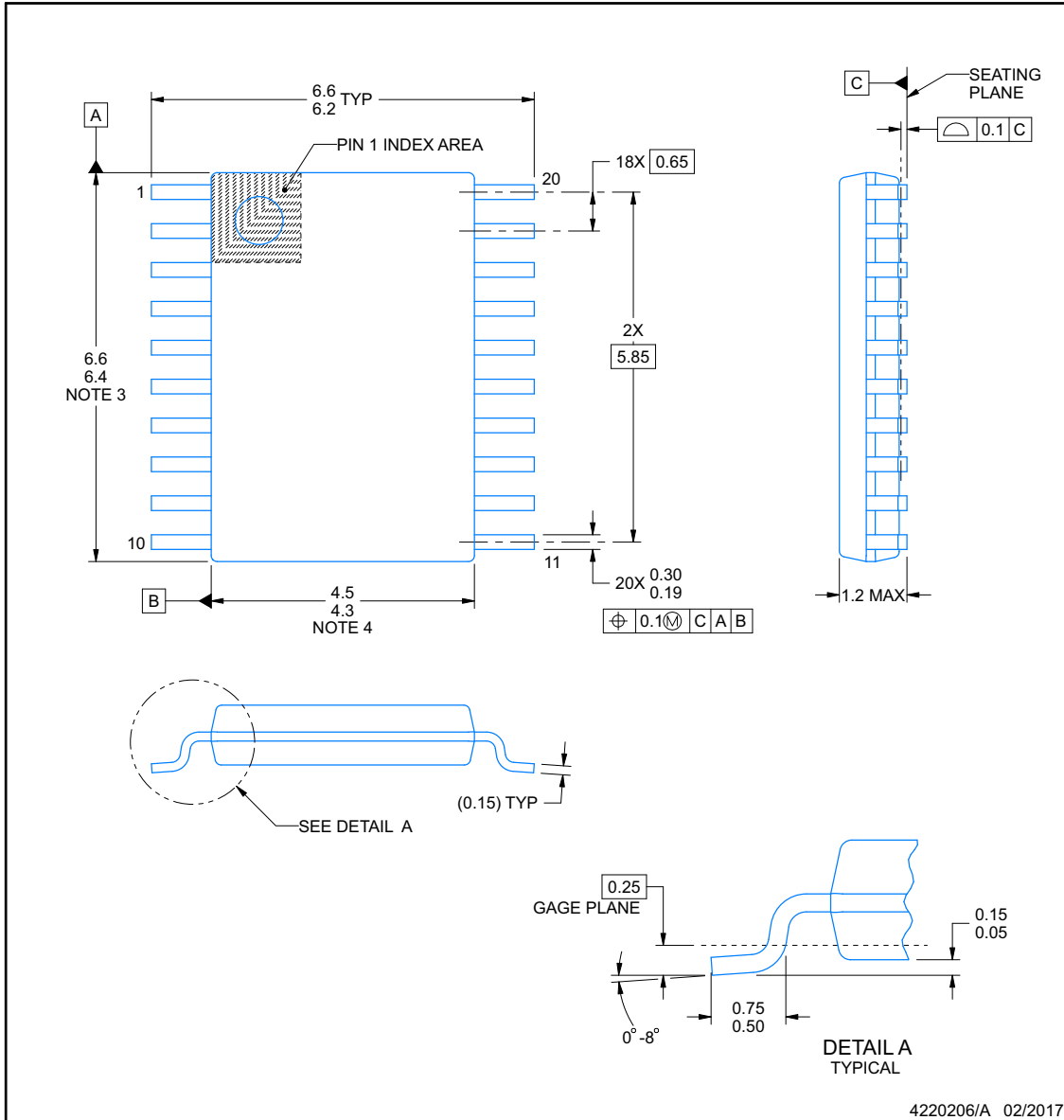

4220206/A 02/2017

NOTES:

1. All linear dimensions are in millimeters. Any dimensions in parenthesis are for reference only. Dimensioning and tolerancing per ASME Y14.5M.
2. This drawing is subject to change without notice.
3. This dimension does not include mold flash, protrusions, or gate burrs. Mold flash, protrusions, or gate burrs shall not exceed 0.15 mm per side.
4. This dimension does not include interlead flash. Interlead flash shall not exceed 0.25 mm per side.
5. Reference JEDEC registration MO-153.

## EXAMPLE BOARD LAYOUT

PW0020A

TSSOP - 1.2 mm max height

SMALL OUTLINE PACKAGE

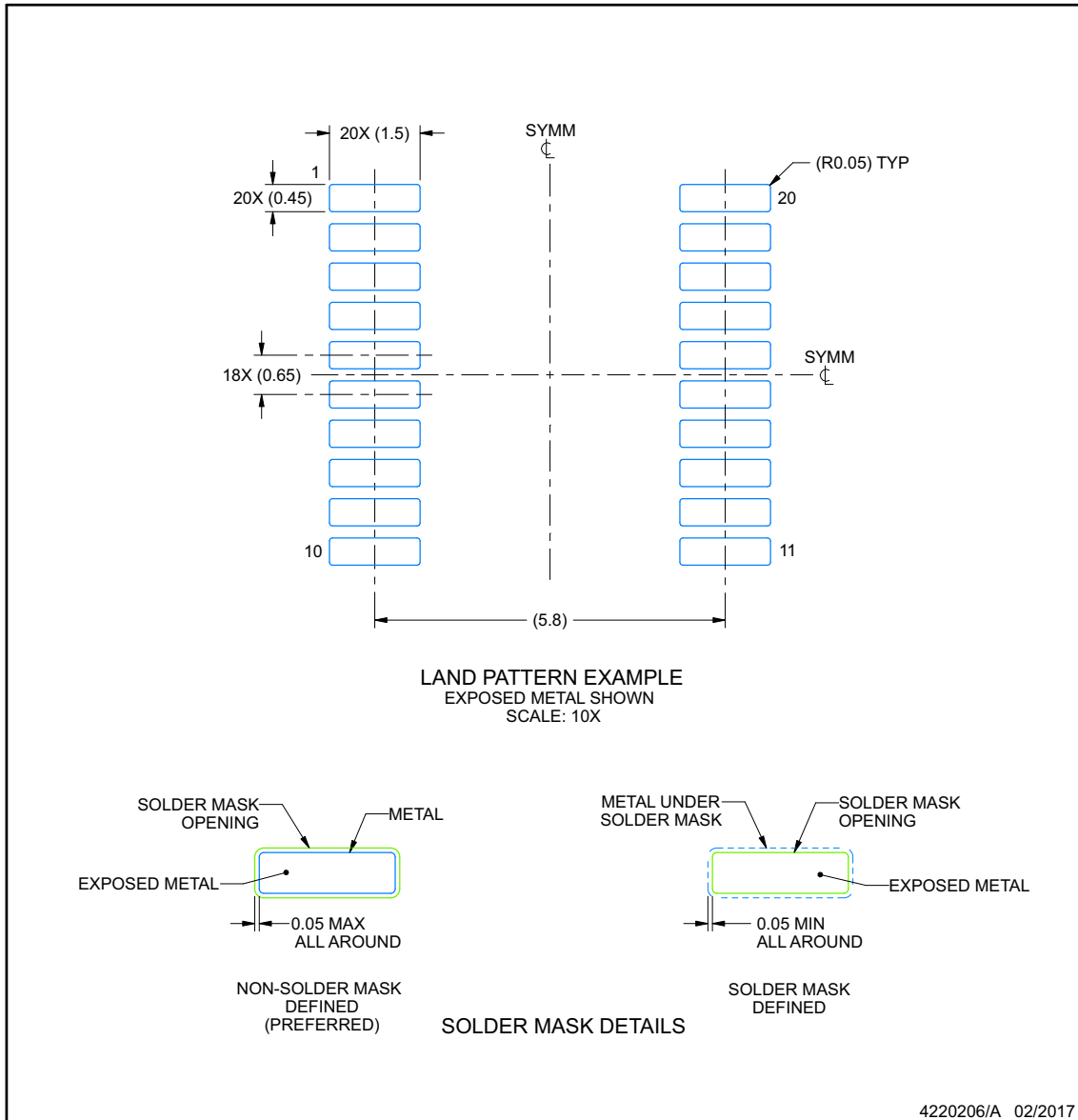

NOTES: (continued)

6. Publication IPC-7351 may have alternate designs.
7. Solder mask tolerances between and around signal pads can vary based on board fabrication site.

## EXAMPLE STENCIL DESIGN

**PW0020A**

**TSSOP - 1.2 mm max height**

SMALL OUTLINE PACKAGE

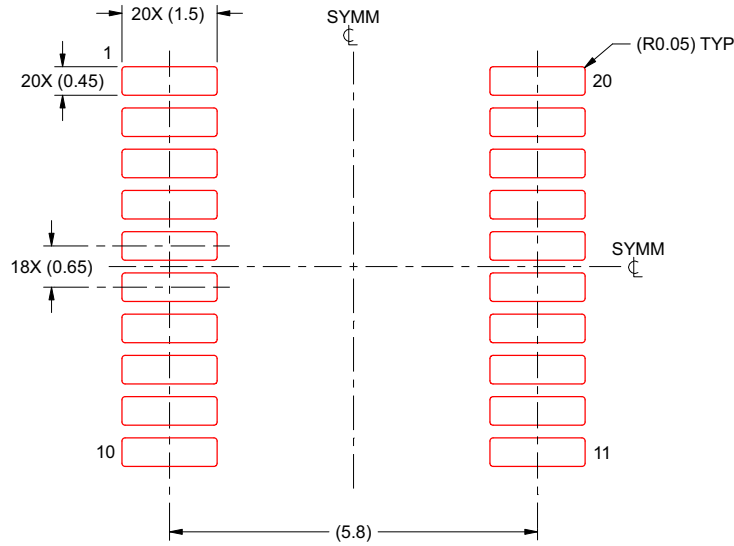

SOLDER PASTE EXAMPLE  
BASED ON 0.125 mm THICK STENCIL  
SCALE: 10X

4220206/A 02/2017

NOTES: (continued)

8. Laser cutting apertures with trapezoidal walls and rounded corners may offer better paste release. IPC-7525 may have alternate design recommendations.
9. Board assembly site may have different recommendations for stencil design.

ADVANCE INFORMATION

## 重要なお知らせと免責事項

テキサス・インスツルメンツは、技術データと信頼性データ(データシートを含みます)、設計リソース(リファレンス デザインを含みます)、アプリケーションや設計に関する各種アドバイス、Web ツール、安全性情報、その他のリソースを、欠陥が存在する可能性のある「現状のまま」提供しており、商品性および特定目的に対する適合性の黙示保証、第三者の知的財産権の非侵害保証を含むいかなる保証も、明示的または黙示的にかかわらず拒否します。

これらのリソースは、テキサス・インスツルメンツ製品を使用する設計の経験を積んだ開発者への提供を意図したものです。(1) お客様のアプリケーションに適したテキサス・インスツルメンツ製品の選定、(2) お客様のアプリケーションの設計、検証、試験、(3) お客様のアプリケーションに該当する各種規格や、その他のあらゆる安全性、セキュリティ、規制、または他の要件への確実な適合に関する責任を、お客様のみが単独で負うものとします。

上記の各種リソースは、予告なく変更される可能性があります。これらのリソースは、リソースで説明されているテキサス・インスツルメンツ製品を使用するアプリケーションの開発の目的でのみ、テキサス・インスツルメンツはその使用をお客様に許諾します。これらのリソースに関して、他の目的で複製することや掲載することは禁止されています。テキサス・インスツルメンツや第三者の知的財産権のライセンスが付与されている訳ではありません。お客様は、これらのリソースを自身で使用した結果発生するあらゆる申し立て、損害、費用、損失、責任について、テキサス・インスツルメンツおよびその代理人を完全に補償するものとし、テキサス・インスツルメンツは一切の責任を拒否します。

テキサス・インスツルメンツの製品は、[テキサス・インスツルメンツの販売条件](#)、または [ti.com](https://www.ti.com) やかかるテキサス・インスツルメンツ製品の関連資料などのいずれかを通じて提供する適用可能な条項の下で提供されています。テキサス・インスツルメンツがこれらのリソースを提供することは、適用されるテキサス・インスツルメンツの保証または他の保証の放棄の拡大や変更を意味するものではありません。

お客様がいかなる追加条項または代替条項を提案した場合でも、テキサス・インスツルメンツはそれらに異議を唱え、拒否します。

郵送先住所: Texas Instruments, Post Office Box 655303, Dallas, Texas 75265  
Copyright © 2024, Texas Instruments Incorporated

**PACKAGING INFORMATION**

Orderable Device	Status (1)	Package Type	Package Drawing	Pins	Package Qty	Eco Plan (2)	Lead finish/ Ball material (6)	MSL Peak Temp (3)	Op Temp (°C)	Device Marking (4/5)	Samples
PSN74LV8T541QPWRQ1	ACTIVE	TSSOP	PW	20	2000	TBD	Call TI	Call TI	-40 to 125		Samples

(1) The marketing status values are defined as follows:

**ACTIVE:** Product device recommended for new designs.

**LIFEBUY:** TI has announced that the device will be discontinued, and a lifetime-buy period is in effect.

**NRND:** Not recommended for new designs. Device is in production to support existing customers, but TI does not recommend using this part in a new design.

**PREVIEW:** Device has been announced but is not in production. Samples may or may not be available.

**OBSELETE:** TI has discontinued the production of the device.

(2) **RoHS:** TI defines "RoHS" to mean semiconductor products that are compliant with the current EU RoHS requirements for all 10 RoHS substances, including the requirement that RoHS substance do not exceed 0.1% by weight in homogeneous materials. Where designed to be soldered at high temperatures, "RoHS" products are suitable for use in specified lead-free processes. TI may reference these types of products as "Pb-Free".

**RoHS Exempt:** TI defines "RoHS Exempt" to mean products that contain lead but are compliant with EU RoHS pursuant to a specific EU RoHS exemption.

**Green:** TI defines "Green" to mean the content of Chlorine (Cl) and Bromine (Br) based flame retardants meet JS709B low halogen requirements of <=1000ppm threshold. Antimony trioxide based flame retardants must also meet the <=1000ppm threshold requirement.

(3) MSL, Peak Temp. - The Moisture Sensitivity Level rating according to the JEDEC industry standard classifications, and peak solder temperature.

(4) There may be additional marking, which relates to the logo, the lot trace code information, or the environmental category on the device.

(5) Multiple Device Markings will be inside parentheses. Only one Device Marking contained in parentheses and separated by a "~" will appear on a device. If a line is indented then it is a continuation of the previous line and the two combined represent the entire Device Marking for that device.

(6) Lead finish/Ball material - Orderable Devices may have multiple material finish options. Finish options are separated by a vertical ruled line. Lead finish/Ball material values may wrap to two lines if the finish value exceeds the maximum column width.

**Important Information and Disclaimer:**The information provided on this page represents TI's knowledge and belief as of the date that it is provided. TI bases its knowledge and belief on information provided by third parties, and makes no representation or warranty as to the accuracy of such information. Efforts are underway to better integrate information from third parties. TI has taken and continues to take reasonable steps to provide representative and accurate information but may not have conducted destructive testing or chemical analysis on incoming materials and chemicals. TI and TI suppliers consider certain information to be proprietary, and thus CAS numbers and other limited information may not be available for release.

In no event shall TI's liability arising out of such information exceed the total purchase price of the TI part(s) at issue in this document sold by TI to Customer on an annual basis.



## 重要なお知らせと免責事項

TI は、技術データと信頼性データ (データシートを含みます)、設計リソース (リファレンス・デザインを含みます)、アプリケーションや設計に関する各種アドバイス、Web ツール、安全性情報、その他のリソースを、欠陥が存在する可能性のある「現状のまま」提供しており、商品性および特定目的に対する適合性の黙示保証、第三者の知的財産権の非侵害保証を含むいかなる保証も、明示的または黙示的にかかわらず拒否します。

これらのリソースは、TI 製品を使用する設計の経験を積んだ開発者への提供を意図したものです。(1) お客様のアプリケーションに適した TI 製品の選定、(2) お客様のアプリケーションの設計、検証、試験、(3) お客様のアプリケーションに該当する各種規格や、その他のあらゆる安全性、セキュリティ、規制、または他の要件への確実な適合に関する責任を、お客様のみが単独で負うものとし、

上記の各種リソースは、予告なく変更される可能性があります。これらのリソースは、リソースで説明されている TI 製品を使用するアプリケーションの開発の目的でのみ、TI はその使用をお客様に許諾します。これらのリソースに関して、他の目的で複製することや掲載することは禁止されています。TI や第三者の知的財産権のライセンスが付与されている訳ではありません。お客様は、これらのリソースを自身で使用した結果発生するあらゆる申し立て、損害、費用、損失、責任について、TI およびその代理人を完全に補償するものとし、TI は一切の責任を拒否します。

TI の製品は、[TI の販売条件](#)、または [ti.com](#) やかかる TI 製品の関連資料などのいずれかを通じて提供する適用可能な条項の下で提供されています。TI がこれらのリソースを提供することは、適用される TI の保証または他の保証の放棄の拡大や変更を意味するものではありません。

お客様がいかなる追加条項または代替条項を提案した場合でも、TI はそれらに異議を唱え、拒否します。

郵送先住所 : Texas Instruments, Post Office Box 655303, Dallas, Texas 75265  
Copyright © 2024, Texas Instruments Incorporated