

SN74LVC1G74 クリア / プリセット搭載、シングル・ポジティブ・エッジ・トリガ型 D-Type フリップ・フロップ

1 特長

- テキサス・インスツルメンツの NanoFree™ パッケージで提供
- 5V V_{CC} 動作をサポート
- 5.5V までの入力電圧に対応
- V_{CC} への降圧変換をサポート
- 最大 t_{pd} : 5.9ns (3.3V 時)
- 低消費電力、最大 I_{CC} : 10 μ A
- 3.3V において ± 24 mA の出力駆動能力
- 標準 V_{OLP} (出力グランド・バウンス)
< 0.8V ($V_{CC} = 3.3V$, $T_A = 25^\circ C$)
- 標準 V_{OHV} (出力 V_{OH} アンダーシュート)
> 2V ($V_{CC} = 3.3V$, $T_A = 25^\circ C$)
- I_{off} により活線挿抜、部分的パワーダウン・モード、バック・ドライブ保護をサポート
- JESD 78、Class II 準拠で 100mA 超のラッチアップ性能
- JESD 22 を超える ESD 保護
 - 人体モデルで 2000V
 - マシン・モデルで 200V
 - デバイス帯電モデルで 1000V

2 アプリケーション

- サーバー
- LED ディスプレイ
- ネットワーク・スイッチ
- 通信インフラ
- モーター・ドライバ
- I/O エクスパンダ

3 概要

このシングル・ポジティブ・エッジ・トリガ D タイプ・フリップ・フロップは、1.65V～5.5V の V_{CC} で動作するように設計されています。

ダイをパッケージとして使用する NanoFree™ パッケージ技術は、IC パッケージの概念を大きく覆すものです。

その他の入力のレベルに関係なく、プリセット (\overline{PRE}) 入力を LOW レベルにすると出力は HIGH になり、クリア (\overline{CLR}) 入力を LOW レベルにすると出力は LOW になります。 \overline{PRE} と \overline{CLR} が非アクティブ (HIGH) の場合、セットアップ時間の要件を満たすデータ (D) 入力のデータは、クロック・パルスの正方向エッジで出力に転送されます。クロックのトリガは電圧レベルで発生し、クロック・パルスの立ち上がり時間とは直接関係しません。ホールド時間が経過した後、D 入力のデータは、出力のレベルに影響を及ぼさずに変化させることができます。

このデバイスは、 I_{off} を使用する部分的パワーダウン・アプリケーション用の動作が完全に規定されています。 I_{off} 回路が出力をディスエーブルにするため、電源切断時にデバイスに電流が逆流して損傷に至ることを回避できます。

製品情報

部品番号	パッケージ (1)	本体サイズ
SN74LVC1G74	SM8 (8)	2.95mm × 2.80mm
	US8 (8)	2.30mm × 2.00mm
	X2SON (8)	1.40mm × 1.00mm
	UQFN (8)	1.50mm × 1.50mm

(1) 利用可能なすべてのパッケージについては、このデータシートの末尾にある注文情報を参照してください。

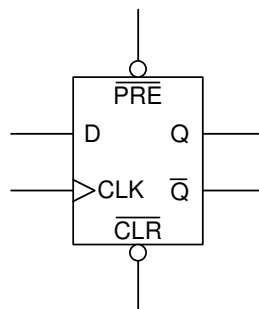

概略回路図



Table of Contents

1 特長.....	1	8.2 Functional Block Diagram.....	10
2 アプリケーション.....	1	8.3 Feature Description.....	10
3 概要.....	1	8.4 Device Functional Modes.....	10
4 Revision History.....	2	9 Application and Implementation.....	11
5 Pin Configuration and Functions.....	4	9.1 Application Information.....	11
6 Specifications.....	5	9.2 Typical Power Button Circuit.....	11
6.1 Absolute Maximum Ratings.....	5	10 Power Supply Recommendations.....	12
6.2 ESD Ratings.....	5	11 Layout.....	13
6.3 Recommended Operating Conditions.....	6	11.1 Layout Guidelines.....	13
6.4 Thermal Information.....	6	11.2 Layout Example.....	13
6.5 Electrical Characteristics.....	7	12 Device and Documentation Support.....	14
6.6 Timing Requirements.....	7	12.1 Receiving Notification of Documentation Updates..	14
6.7 Switching Characteristics.....	7	12.2 サポート・リソース.....	14
6.8 Operating Characteristics.....	8	12.3 Trademarks.....	14
6.9 Typical Characteristics.....	8	12.4 Electrostatic Discharge Caution.....	14
7 Parameter Measurement Information.....	9	12.5 Glossary.....	14
8 Detailed Description.....	10	13 Mechanical, Packaging, and Orderable Information.....	14
8.1 Overview.....	10		

4 Revision History

資料番号末尾の英字は改訂を表しています。その改訂履歴は英語版に準じています。

Changes from Revision F (April 2020) to Revision G (September 2021)	Page
• 文書全体にわたって表、図、相互参照の採番方法を更新.....	1
• Updated the <i>Application and Information</i> section.....	11
• Updated the <i>Device Power Button Circuit</i> figure <i>Typical Power Button Circuit</i> section.....	11
Changes from Revision E (January 2015) to Revision F (April 2020)	Page
• Match RSE pinout with signal names.....	4
Changes from Revision D (January 2013) to Revision E (January 2015)	Page
• 「アプリケーション」セクション、「製品情報」表、「端子機能」表、「ESD 定格」表、「熱に関する情報」表、「{代表的特性}」セクション、「{機能説明}」セクション、「{デバイスの機能モード}」セクション、「{アプリケーションと実装}」セクション、「{電源に関する推奨事項}」セクション、「{レイアウト}」セクション、「{デバイスおよびドキュメントのサポート}」セクション、「{メカニカル、パッケージ、および注文情報}」セクションを追加.....	1
• 「注文情報」表を削除.....	1
• 「特長」を更新.....	1
Changes from Revision C (November 2012) to Revision D (January 2013)	Page
• DQE パッケージの熱特性データを削除.....	1
• Added Thermal data for DQE Package.....	6
Changes from Revision B (March 2012) to Revision C (November 2012)	Page
• RES 部品のプレビューを追加.....	1
• Added QFN package ordering information.....	14
Changes from Revision A (November 2011) to Revision B (February 2012)	Page
• Added SN74LVC1G74DCURG4 part number to ORDERING INFORMATION table.....	14
Changes from Revision * (October 2009) to Revision A (November 2011)	Page
• 「特長」の I_{off} の説明を変更.....	1

-
- Changed temperature range for DCT and DCU package from (–40°C to 85°C) to (–40°C to 125°C)..... 6
 - Changed *Timing Requirements* table..... 7
 - Changed *Switching Requirements* table..... 7
-

5 Pin Configuration and Functions

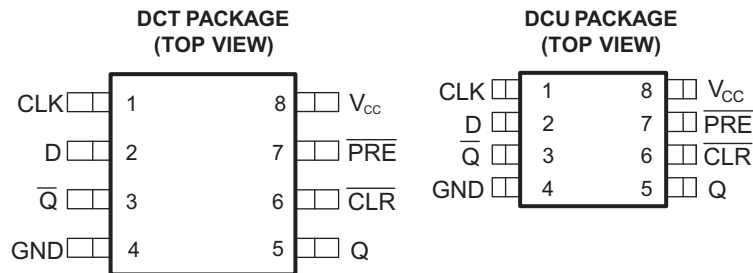

See mechanical drawings for dimensions.

5-1. DCT 8-Pin SM8 and DCU 8-Pin VSSOP Package Top View

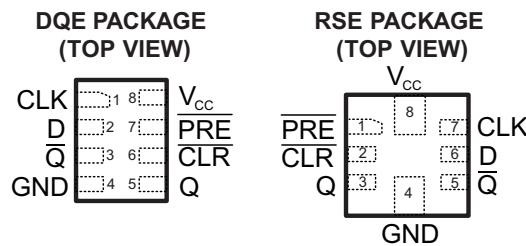

See mechanical drawings for dimensions

5-2. DQE 8-Pin X2SON and RSE UQFN 8-Pin Package Top View

Pin Functions

PIN		TYPE	DESCRIPTION
NAME	NO.		
CLK	1	I	Clock input
CLR	6	I	Clear input – Pull low to set Q output low
D	2	I	Input
GND	4	—	Ground
PRE	7	I	Preset input – Pull low to set Q output high
Q	5	O	Output
Q̄	3	O	Inverted output
V _{CC}	8	—	Supply

6 Specifications

6.1 Absolute Maximum Ratings

over operating free-air temperature range (unless otherwise noted)⁽¹⁾

		MIN	MAX	UNIT
V _{CC}	Supply voltage range	-0.5	6.5	V
V _I	Input voltage range ⁽²⁾	-0.5	6.5	V
V _O	Voltage range applied to any output in the high-impedance or power-off state ⁽²⁾	-0.5	6.5	V
V _O	Voltage range applied to any output in the high or low state ⁽²⁾ ⁽³⁾	-0.5	V _{CC} + 0.5	V
I _{IK}	Input clamp current	V _I < 0		-50 mA
I _{OK}	Output clamp current	V _O < 0		-50 mA
I _O	Continuous output current			±50 mA
	Continuous current through V _{CC} or GND			±100 mA
T _{stg}	Storage temperature range	-65	150	°C

- (1) Stresses beyond those listed under *Absolute Maximum Ratings* may cause permanent damage to the device. These are stress ratings only, and functional operation of the device at these or any other conditions beyond those indicated under *Recommended Operating Conditions* is not implied. Exposure to absolute-maximum-rated conditions for extended periods may affect device reliability.
- (2) The input negative-voltage and output voltage ratings may be exceeded if the input and output clamp-current ratings are observed.
- (3) The value of V_{CC} is provided in the *Recommended Operating Conditions* table.

6.2 ESD Ratings

PARAMETER	DEFINITION	VALUE	UNIT
V _(ESD)	Human body model (HBM), per ANSI/ESDA/JEDEC JS-001, all pins ⁽¹⁾	2000	V
	Charged device model (CDM), per JEDEC specification JESD22-C101, all pins ⁽²⁾	1000	

- (1) JEDEC document JEP155 states that 500-V HBM allows safe manufacturing with a standard ESD control process.
- (2) JEDEC document JEP157 states that 250-V CDM allows safe manufacturing with a standard ESD control process.

6.3 Recommended Operating Conditions

over operating free-air temperature range (unless otherwise noted)⁽¹⁾

			MIN	MAX	UNIT
V _{CC}	Supply voltage	Operating	1.65	5.5	V
		Data retention only	1.5		
V _{IH}	High-level input voltage	V _{CC} = 1.65 V to 1.95 V	0.65 × V _{CC}		V
		V _{CC} = 2.3 V to 2.7 V	1.7		
		V _{CC} = 3 V to 3.6 V	2		
		V _{CC} = 4.5 V to 5.5 V	0.7 × V _{CC}		
V _{IL}	Low-level input voltage	V _{CC} = 1.65 V to 1.95 V		0.35 × V _{CC}	V
		V _{CC} = 2.3 V to 2.7 V		0.7	
		V _{CC} = 3 V to 3.6 V		0.8	
		V _{CC} = 4.5 V to 5.5 V		0.3 × V _{CC}	
V _I	Input voltage		0	5.5	V
V _O	Output voltage		0	V _{CC}	V
I _{OH}	High-level output current	V _{CC} = 1.65 V		-4	mA
		V _{CC} = 2.3 V		-8	
		V _{CC} = 3 V		-16	
		V _{CC} = 4.5 V		-24	
I _{OL}	Low-level output current	V _{CC} = 1.65 V		4	mA
		V _{CC} = 2.3 V		8	
		V _{CC} = 3 V		16	
		V _{CC} = 4.5 V		24	
Δt/Δv	Input transition rise or fall rate	V _{CC} = 1.8 V ± 0.15 V, 2.5 V ± 0.2 V		20	ns/V
		V _{CC} = 3.3 V ± 0.3 V		10	
		V _{CC} = 5 V ± 0.5 V		5	
T _A	Operating free-air temperature	RSE Package	-40	85	°C
		DQE Package			
		DCT Package	-40	125	
		DCU Package			

(1) All unused inputs of the device must be held at V_{CC} or GND to ensure proper device operation. Refer to the TI application report, *Implications of Slow or Floating CMOS Inputs*, literature number [SCBA004](#).

6.4 Thermal Information

THERMAL METRIC ⁽¹⁾	SN74LVC1G74				UNIT	
	DCT	DCU	RSE	DQE		
	8 PINS	8 PINS	8 PINS	8 PINS		
R _{θJA}	Junction-to-ambient thermal resistance	220	227	243	261	°C/W

(1) For more information about traditional and new thermal metrics, see the *IC Package Thermal Metrics* application report, [SPRA953](#).

6.5 Electrical Characteristics

over recommended operating free-air temperature range (unless otherwise noted)

PARAMETER		TEST CONDITIONS	V _{CC}	MIN	TYP ⁽¹⁾	MAX	UNIT
V _{OH}		I _{OH} = -100 μA	1.65 V to 5.5 V	V _{CC} - 0.1			V
		I _{OH} = -4 mA	1.65 V	1.2			
		I _{OH} = -8 mA	2.3 V	1.9			
		I _{OH} = -16 mA	3 V	2.4			
		I _{OH} = -24 mA		2.3			
		I _{OH} = -32 mA	4.5 V	3.8			
V _{OL}		I _{OL} = 100 μA	1.65 V to 5.5 V			0.1	V
		I _{OL} = 4 mA	1.65 V			0.45	
		I _{OL} = 8 mA	2.3 V			0.3	
		I _{OL} = 16 mA	3 V			0.4	
		I _{OL} = 24 mA				0.55	
		I _{OL} = 32 mA	4.5 V			0.55	
I _I	Data or control inputs	V _I = 5.5 V or GND	0 to 5.5 V			±5	μA
I _{off}		V _I or V _O = 5.5 V	0			±10	μA
I _{CC}		V _I = 5.5 V or GND, I _O = 0	1.65 V to 5.5 V			10	μA
ΔI _{CC}		One input at V _{CC} - 0.6 V, Other inputs at V _{CC} or GND	3 V to 5.5 V			500	μA
C _i		V _I = V _{CC} or GND	3.3 V			5	pF

(1) All typical values are at V_{CC} = 3.3 V, T_A = 25°C.

6.6 Timing Requirements

over recommended operating free-air temperature range (unless otherwise noted) (see [7-1](#))

PARAMETER	FROM (INPUT)	TO (OUTPUT)	-40°C to 85°C								-40°C to 125°C				UNIT
			V _{CC} = 1.8 V		V _{CC} = 2.5 V		V _{CC} = 3.3 V		V _{CC} = 5 V		V _{CC} = 3.3 V		V _{CC} = 5 V		
			MIN	MAX	MIN	MAX	MIN	MAX	MIN	MAX	MIN	MAX	MIN	MAX	
f _{clock}			80		175		175		200		175		200		MHz
t _w		CLK	6.2		2.7		2.7		2		2.7		2		ns
		PRE or CLR low	6.2		2.7		2.7		2		2.7		2		ns
t _{su}		Data	2.9		1.7		1.3		1.1		1.3		1.1		ns
		PRE or CLR inactive	1.9		1.4		1.2		1		1.2		1.2		ns
t _h			0		0.3		1.2		0.5		1.2		0.5		ns

6.7 Switching Characteristics

over recommended operating free-air temperature range (unless otherwise noted) (see [7-1](#))

PARAMETER	FROM (INPUT)	TO (OUTPUT)	-40°C to 85°C								-40°C to 125°C				UNIT
			V _{CC} = 1.8 V		V _{CC} = 2.5 V		V _{CC} = 3.3 V		V _{CC} = 5 V		V _{CC} = 3.3 V		V _{CC} = 5 V		
			MIN	MAX	MIN	MAX	MIN	MAX	MIN	MAX	MIN	MAX	MIN	MAX	
f _{max}			80		175		175		200		175		200		MHz
t _{pd}	CLK	Q	4.8	13.4	2.2	7.1	2.2	5.9	1.4	4.1	2.2	7.9	1.4	6.1	ns
		Q̄	6	14.4	3	7.7	2.6	6.2	1.6	4.4	2.6	8.2	1.6	6.4	
	PRE or CLR low	Q or Q̄	4.4	12.9	2.3	7	1.7	5.9	1.6	4.1	1.7	7.9	1.6	6.1	

6.8 Operating Characteristics

T_A = 25°C

PARAMETER	TEST CONDITIONS	V _{CC} = 1.8 V	V _{CC} = 2.5 V	V _{CC} = 3.3 V	V _{CC} = 5 V	UNIT
		TYP	TYP	TYP	TYP	
C _{pd} Power dissipation capacitance	f = 10 MHz	35	35	37	40	pF

6.9 Typical Characteristics

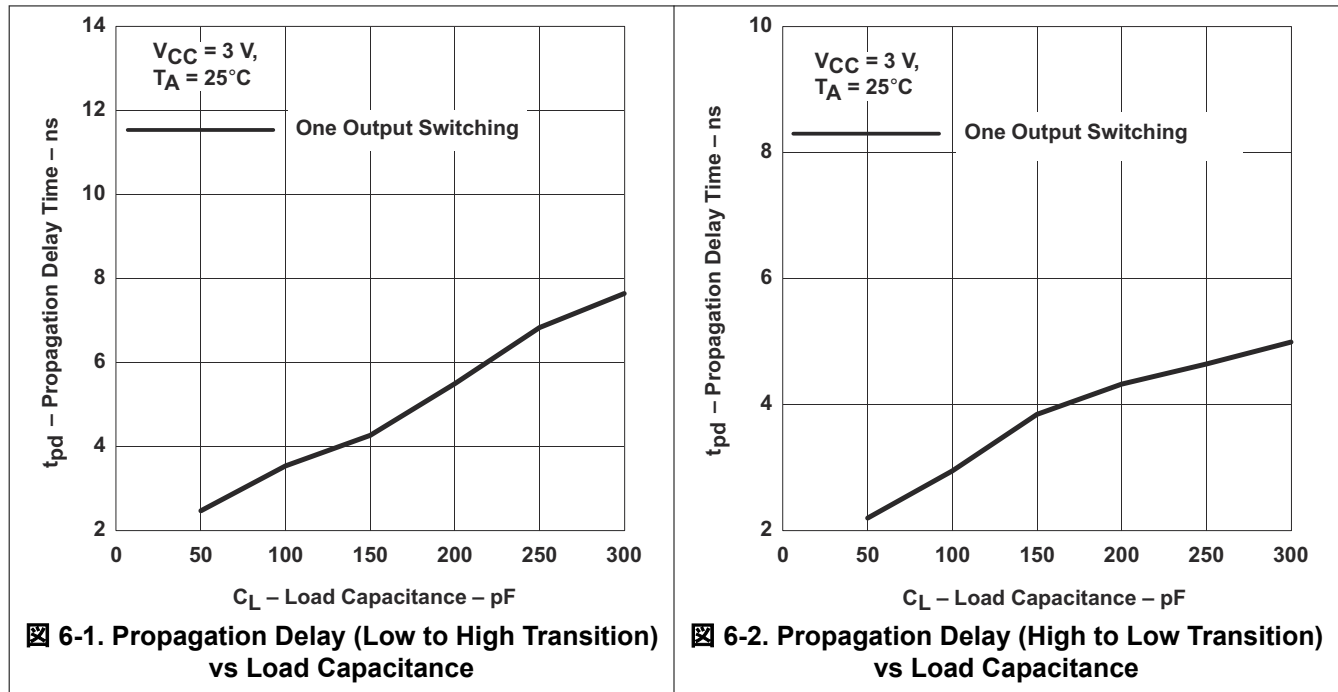

7 Parameter Measurement Information

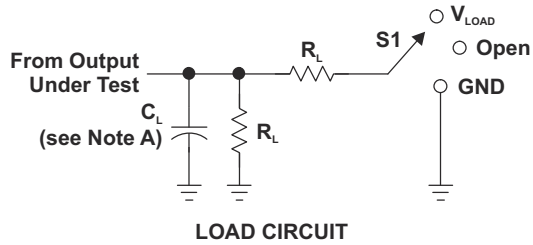

TEST	S1
t_{PLH}/t_{PHL}	Open
t_{PLZ}/t_{PZL}	V_{LOAD}
t_{PHZ}/t_{PZH}	GND

V_{CC}	INPUTS		V_M	V_{LOAD}	C_L	R_L	V_{Δ}
	V_I	t_r/t_f					
$1.8\text{ V} \pm 0.15\text{ V}$	V_{CC}	$\leq 2\text{ ns}$	$V_{CC}/2$	$2 \times V_{CC}$	30 pF	1 k Ω	0.15 V
$2.5\text{ V} \pm 0.2\text{ V}$	V_{CC}	$\leq 2\text{ ns}$	$V_{CC}/2$	$2 \times V_{CC}$	30 pF	500 Ω	0.15 V
$3.3\text{ V} \pm 0.3\text{ V}$	3 V	$\leq 2.5\text{ ns}$	1.5 V	6 V	50 pF	500 Ω	0.3 V
$5\text{ V} \pm 0.5\text{ V}$	V_{CC}	$\leq 2.5\text{ ns}$	$V_{CC}/2$	$2 \times V_{CC}$	50 pF	500 Ω	0.3 V

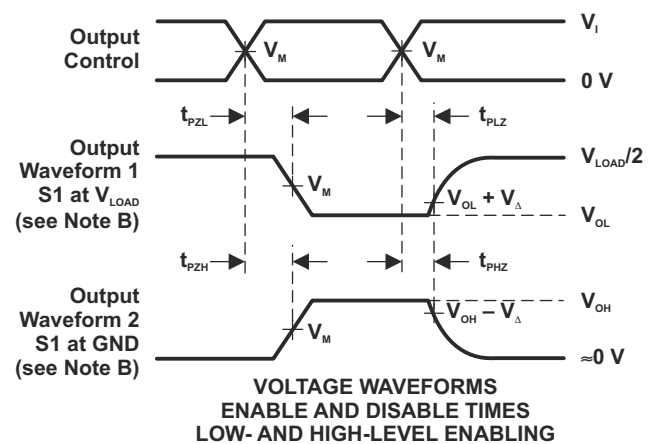
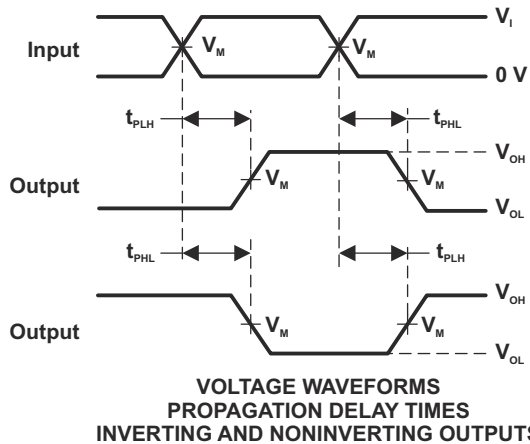
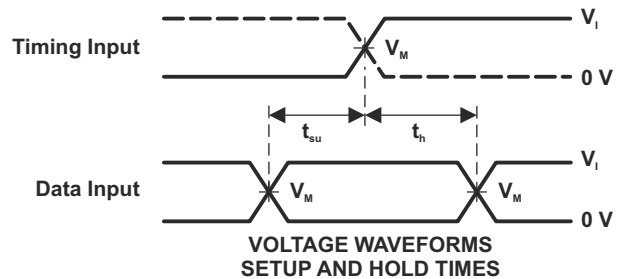
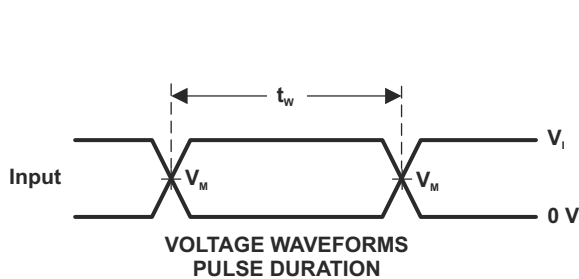

- NOTES: A. C_L includes probe and jig capacitance.
 B. Waveform 1 is for an output with internal conditions such that the output is low, except when disabled by the output control. Waveform 2 is for an output with internal conditions such that the output is high, except when disabled by the output control.
 C. All input pulses are supplied by generators having the following characteristics: $PRR \leq 10\text{ MHz}$, $Z_o = 50\ \Omega$.
 D. The outputs are measured one at a time, with one transition per measurement.
 E. t_{PLZ} and t_{PHZ} are the same as t_{dis} .
 F. t_{PZL} and t_{PZH} are the same as t_{en} .
 G. t_{PLH} and t_{PHL} are the same as t_{pd} .
 H. All parameters and waveforms are not applicable to all devices.

7-1. Load Circuit and Voltage Waveforms

8 Detailed Description

8.1 Overview

This device is fully specified for partial-power-down applications using I_{off} . The I_{off} circuitry disables the outputs, preventing damaging current backflow through the device when it is powered down.

8.2 Functional Block Diagram

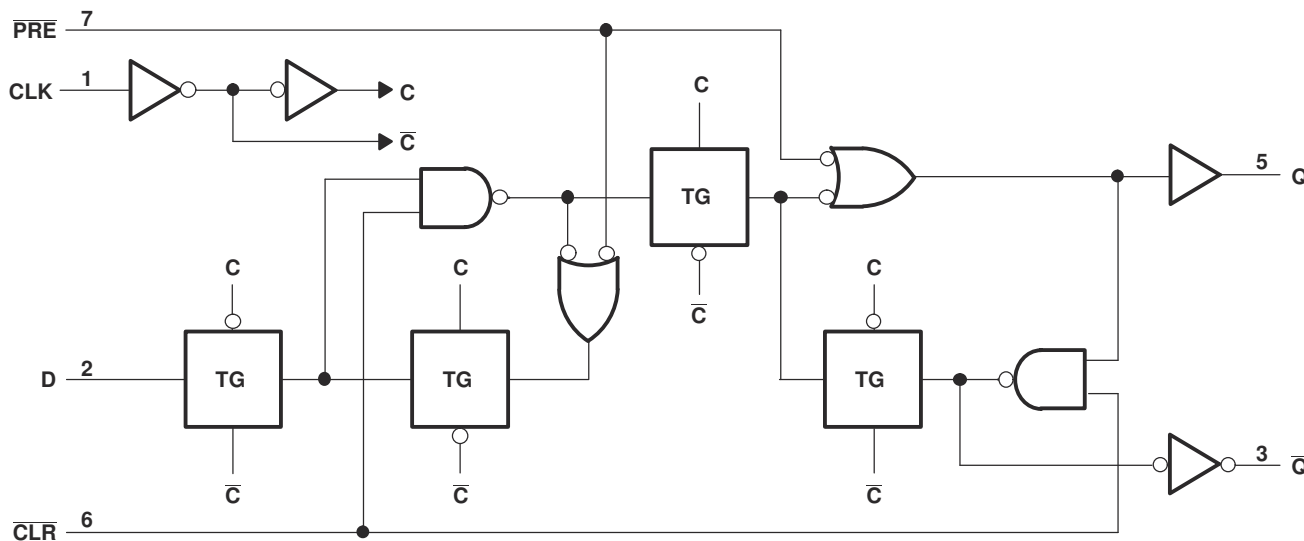

8.3 Feature Description

- Allow down voltage translation
 - 5-V to 3.3-V
 - 5.0-V to 1.8-V
 - 3.3-V to 1.8-V
- Inputs accept voltage levels up to 5.5-V
- I_{off} Feature
 - Can prevent backflow current that can damage device when powered down

8.4 Device Functional Modes

表 8-1. Function Table

INPUTS				OUTPUTS	
PRE	CLR	CLK	D	Q	\bar{Q}
L	H	X	X	H	L
H	L	X	X	L	H
L	L	X	X	H ⁽¹⁾	H ⁽¹⁾
H	H	\uparrow	H	H	L
H	H	\uparrow	L	L	H
H	H	L	X	Q_0	\bar{Q}_0

(1) This configuration is nonstable; that is, it does not persist when \overline{PRE} or \overline{CLR} returns to its inactive (high) level.

9 Application and Implementation

Note

以下のアプリケーション情報は、TI の製品仕様に含まれるものではなく、TI ではその正確性または完全性を保証いたしません。個々の目的に対する製品の適合性については、お客様の責任で判断していただくこととなります。お客様は自身の設計実装を検証しテストすることで、システムの機能を確認する必要があります。

9.1 Application Information

A low level at the preset ($\overline{\text{PRE}}$) or clear ($\overline{\text{CLR}}$) input sets or resets the outputs, regardless of the levels of the other inputs. When $\overline{\text{PRE}}$ and $\overline{\text{CLR}}$ are inactive (high), data at the data (D) input meeting the setup time requirements is transferred to the outputs on the positive-going edge of the clock pulse. Clock triggering occurs at a voltage level and is not related directly to the rise time of the clock pulse. Following the hold-time interval, data at the D input can be changed without affecting the levels at the outputs.

The 330 Ω resistor and 22 pF capacitor shown in [Figure 9-1](#) produce enough delay to meet the hold time requirement of the D input. To calculate the delay for a particular RC combination, use [Equation 1](#). The delay with this RC combination is 5.03 ns

$$t_{\text{delay}} = -RC \ln(0.5) \approx 0.693 RC \quad (1)$$

To ensure proper operation, check that the transition time of the RC circuit meets the transition time requirements of the device inputs listed in the Recommended Operating Conditions table. Transition time for an RC can be approximated with [Equation 2](#).

$$t_t \approx 2.2 RC \quad (2)$$

9.2 Typical Power Button Circuit

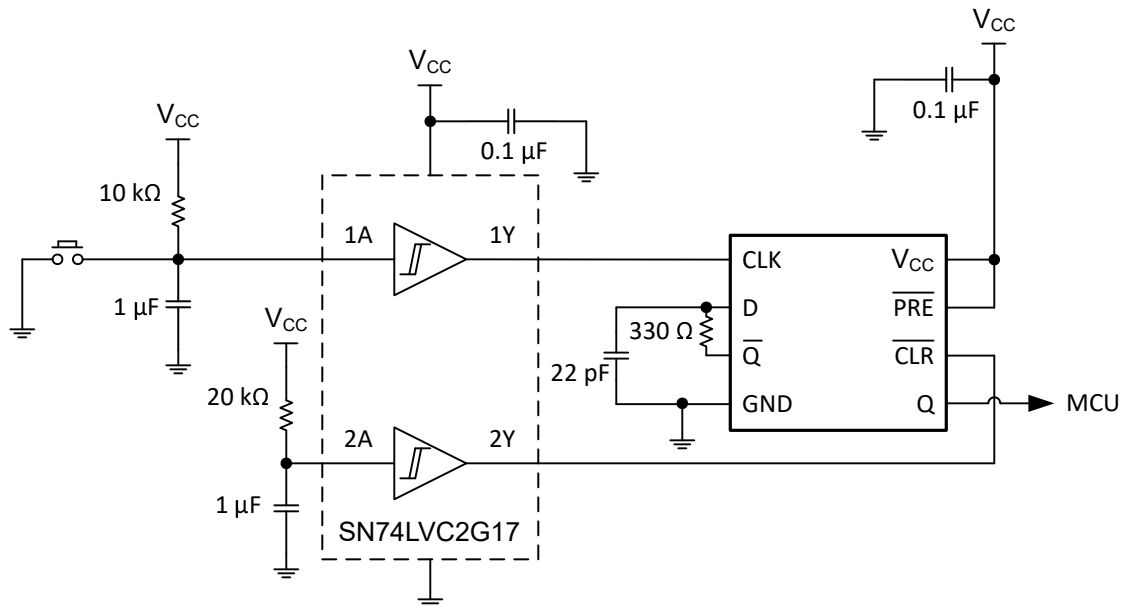

Figure 9-1. Device Power Button Circuit

9.2.1 Design Requirements

This device uses CMOS technology and has balanced output drive. Care should be taken to avoid bus contention because it can drive currents that would exceed maximum limits. Outputs can be combined to produce higher drive but the high drive will also create faster edges into light loads so routing and load conditions should be considered to prevent ringing.

9.2.2 Detailed Design Procedure

1. Recommended Input Conditions:

- For rise time and fall time specifications, see $(\Delta t/\Delta V)$ in the [Recommended Operating Conditions](#) table.
- For specified high and low levels, see $(V_{IH}$ and $V_{IL})$ in the [Recommended Operating Conditions](#) table.
- Inputs are overvoltage tolerant allowing them to go as high as 5.5-V at any valid V_{CC} .

2. Recommend Output Conditions:

- Load currents should not exceed 50-mA per output and 100-mA total for the part.
- Series resistors on the output may be used if the user desires to slow the output edge signal or limit the output current.

9.2.3 Application Curves

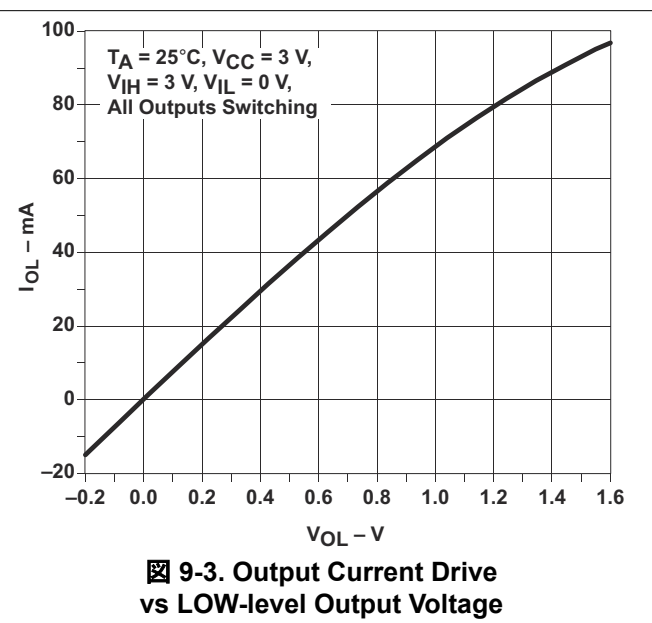
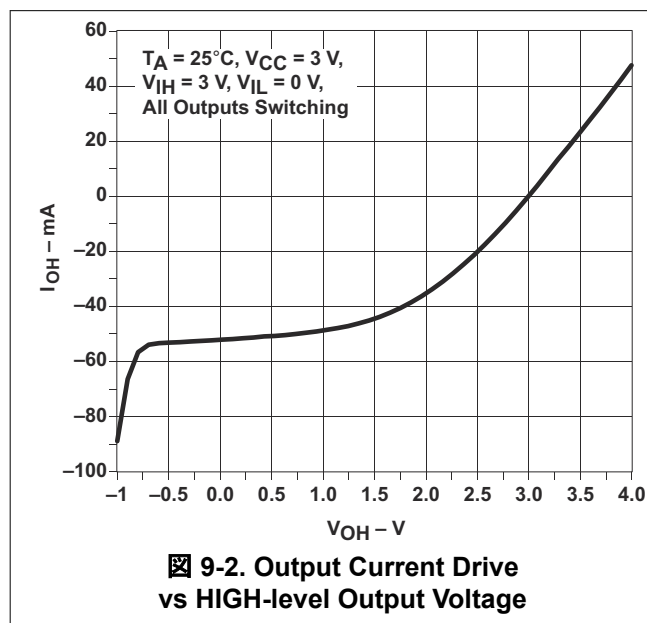

10 Power Supply Recommendations

The power supply can be any voltage between the minimum and maximum supply voltage rating located in the [Recommended Operating Conditions](#) table. Each V_{CC} terminal should have a good bypass capacitor to prevent power disturbance. For devices with a single supply, a 0.1- μF capacitor is recommended and if there are multiple V_{CC} terminals then .01- μF or .022- μF capacitors are recommended for each power terminal. It is acceptable to parallel multiple bypass caps to reject different frequencies of noise. The 0.1- μF and 1- μF capacitors are commonly used in parallel. The bypass capacitor should be installed as close to the power terminal as possible for best results.

11 Layout

11.1 Layout Guidelines

When using multiple bit logic devices, inputs should not float. In many cases, functions or parts of functions of digital logic devices are unused. Some examples are when only two inputs of a triple-input AND gate are used, or when only 3 of the 4-buffer gates are used. Such input pins should not be left unconnected because the undefined voltages at the outside connections result in undefined operational states.

Specified in [Figure 11-1](#) are rules that must be observed under all circumstances. All unused inputs of digital logic devices must be connected to a high or low bias to prevent them from floating. The logic level that should be applied to any particular unused input depends on the function of the device. Generally they will be tied to GND or V_{CC} , whichever makes more sense or is more convenient. It is acceptable to float outputs unless the part is a transceiver. If the transceiver has an output enable pin, it will disable the outputs section of the part when asserted. This will not disable the input section of the I/Os so they also cannot float when disabled.

11.2 Layout Example

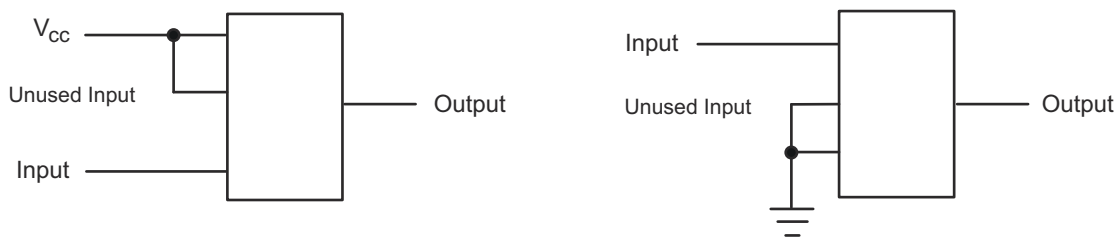

Figure 11-1. Layout Diagram

12 Device and Documentation Support

12.1 Receiving Notification of Documentation Updates

To receive notification of documentation updates, navigate to the device product folder on ti.com. Click on *Subscribe to updates* to register and receive a weekly digest of any product information that has changed. For change details, review the revision history included in any revised document.

12.2 サポート・リソース

TI E2E™ サポート・フォーラムは、エンジニアが検証済みの回答と設計に関するヒントをエキスパートから迅速かつ直接得ることができる場所です。既存の回答を検索したり、独自の質問をしたりすることで、設計に必要な支援を迅速に得ることができます。

リンクされているコンテンツは、該当する貢献者により、現状のまま提供されるものです。これらは TI の仕様を構成するものではなく、必ずしも TI の見解を反映したものではありません。TI の [使用条件](#) を参照してください。

12.3 Trademarks

NanoFree™ is a trademark of Texas Instruments.

TI E2E™ is a trademark of Texas Instruments.

すべての商標は、それぞれの所有者に帰属します。

12.4 Electrostatic Discharge Caution



This integrated circuit can be damaged by ESD. Texas Instruments recommends that all integrated circuits be handled with appropriate precautions. Failure to observe proper handling and installation procedures can cause damage.

ESD damage can range from subtle performance degradation to complete device failure. Precision integrated circuits may be more susceptible to damage because very small parametric changes could cause the device not to meet its published specifications.

12.5 Glossary

[TI Glossary](#) This glossary lists and explains terms, acronyms, and definitions.

13 Mechanical, Packaging, and Orderable Information

The following pages include mechanical packaging and orderable information. This information is the most current data available for the designated devices. This data is subject to change without notice and revision of this document. For browser based versions of this data sheet, refer to the left hand navigation.

PACKAGING INFORMATION

Orderable Device	Status (1)	Package Type	Package Drawing	Pins	Package Qty	Eco Plan (2)	Lead finish/ Ball material (6)	MSL Peak Temp (3)	Op Temp (°C)	Device Marking (4/5)	Samples
SN74LVC1G74DCTR	ACTIVE	SSOP	DCT	8	3000	RoHS & Green	NIPDAU SN	Level-1-260C-UNLIM	-40 to 125	(2WE5, N74) Z	Samples
SN74LVC1G74DCUR	ACTIVE	VSSOP	DCU	8	3000	RoHS & Green	NIPDAU SN	Level-1-260C-UNLIM	-40 to 125	(N74J, N74Q, N74R)	Samples
SN74LVC1G74DCURG4	ACTIVE	VSSOP	DCU	8	3000	RoHS & Green	NIPDAU	Level-1-260C-UNLIM	-40 to 125	N74R	Samples
SN74LVC1G74DCUT	ACTIVE	VSSOP	DCU	8	250	RoHS & Green	NIPDAU SN	Level-1-260C-UNLIM	-40 to 125	(N74J, N74Q, N74R)	Samples
SN74LVC1G74DQER	ACTIVE	X2SON	DQE	8	5000	RoHS & Green	NIPDAU	Level-1-260C-UNLIM	-40 to 125	DP	Samples
SN74LVC1G74RSE2	ACTIVE	UQFN	RSE	8	5000	RoHS & Green	NIPDAU	Level-1-260C-UNLIM	-40 to 125	DP	Samples
SN74LVC1G74RSER	ACTIVE	UQFN	RSE	8	5000	RoHS & Green	NIPDAU	Level-1-260C-UNLIM	-40 to 125	DP	Samples

(1) The marketing status values are defined as follows:

ACTIVE: Product device recommended for new designs.

LIFEBUY: TI has announced that the device will be discontinued, and a lifetime-buy period is in effect.

NRND: Not recommended for new designs. Device is in production to support existing customers, but TI does not recommend using this part in a new design.

PREVIEW: Device has been announced but is not in production. Samples may or may not be available.

OBSOLETE: TI has discontinued the production of the device.

(2) **RoHS:** TI defines "RoHS" to mean semiconductor products that are compliant with the current EU RoHS requirements for all 10 RoHS substances, including the requirement that RoHS substance do not exceed 0.1% by weight in homogeneous materials. Where designed to be soldered at high temperatures, "RoHS" products are suitable for use in specified lead-free processes. TI may reference these types of products as "Pb-Free".

RoHS Exempt: TI defines "RoHS Exempt" to mean products that contain lead but are compliant with EU RoHS pursuant to a specific EU RoHS exemption.

Green: TI defines "Green" to mean the content of Chlorine (Cl) and Bromine (Br) based flame retardants meet JS709B low halogen requirements of <=1000ppm threshold. Antimony trioxide based flame retardants must also meet the <=1000ppm threshold requirement.

(3) MSL, Peak Temp. - The Moisture Sensitivity Level rating according to the JEDEC industry standard classifications, and peak solder temperature.

(4) There may be additional marking, which relates to the logo, the lot trace code information, or the environmental category on the device.

(5) Multiple Device Markings will be inside parentheses. Only one Device Marking contained in parentheses and separated by a "~" will appear on a device. If a line is indented then it is a continuation of the previous line and the two combined represent the entire Device Marking for that device.

⁽⁶⁾ Lead finish/Ball material - Orderable Devices may have multiple material finish options. Finish options are separated by a vertical ruled line. Lead finish/Ball material values may wrap to two lines if the finish value exceeds the maximum column width.

Important Information and Disclaimer:The information provided on this page represents TI's knowledge and belief as of the date that it is provided. TI bases its knowledge and belief on information provided by third parties, and makes no representation or warranty as to the accuracy of such information. Efforts are underway to better integrate information from third parties. TI has taken and continues to take reasonable steps to provide representative and accurate information but may not have conducted destructive testing or chemical analysis on incoming materials and chemicals. TI and TI suppliers consider certain information to be proprietary, and thus CAS numbers and other limited information may not be available for release.

In no event shall TI's liability arising out of such information exceed the total purchase price of the TI part(s) at issue in this document sold by TI to Customer on an annual basis.

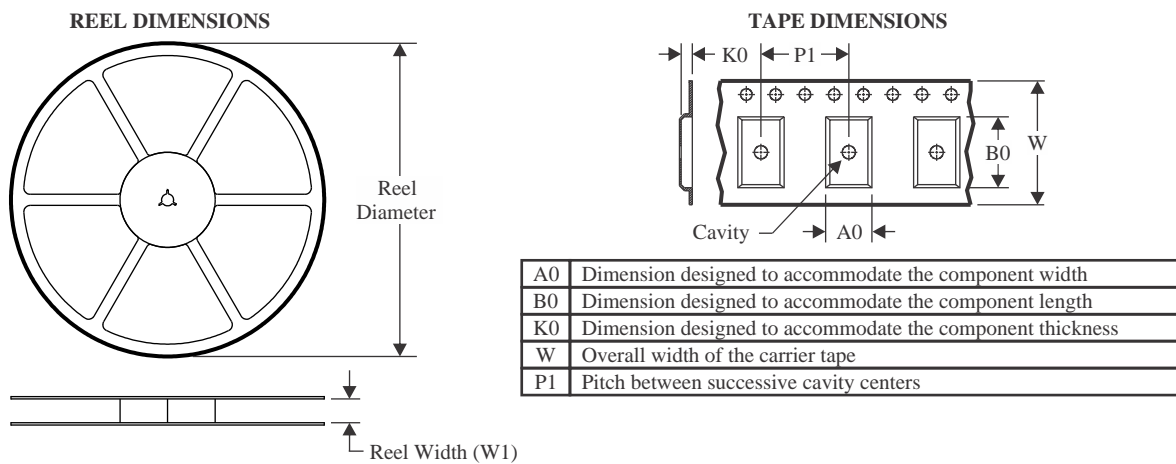
TAPE AND REEL INFORMATION

QUADRANT ASSIGNMENTS FOR PIN 1 ORIENTATION IN TAPE



*All dimensions are nominal

Device	Package Type	Package Drawing	Pins	SPQ	Reel Diameter (mm)	Reel Width W1 (mm)	A0 (mm)	B0 (mm)	K0 (mm)	P1 (mm)	W (mm)	Pin1 Quadrant
SN74LVC1G74DCTR	SSOP	DCT	8	3000	180.0	12.4	3.15	4.35	1.55	4.0	12.0	Q3
SN74LVC1G74DCUR	VSSOP	DCU	8	3000	178.0	9.0	2.25	3.35	1.05	4.0	8.0	Q3
SN74LVC1G74DCURG4	VSSOP	DCU	8	3000	180.0	8.4	2.25	3.35	1.05	4.0	8.0	Q3
SN74LVC1G74DCUT	VSSOP	DCU	8	250	178.0	9.0	2.25	3.35	1.05	4.0	8.0	Q3
SN74LVC1G74DQER	X2SON	DQE	8	5000	180.0	9.5	1.15	1.6	0.5	4.0	8.0	Q1
SN74LVC1G74RSE2	UQFN	RSE	8	5000	180.0	9.5	1.7	1.7	0.75	4.0	8.0	Q3
SN74LVC1G74RSER	UQFN	RSE	8	5000	180.0	9.5	1.7	1.7	0.75	4.0	8.0	Q2

TAPE AND REEL BOX DIMENSIONS

*All dimensions are nominal

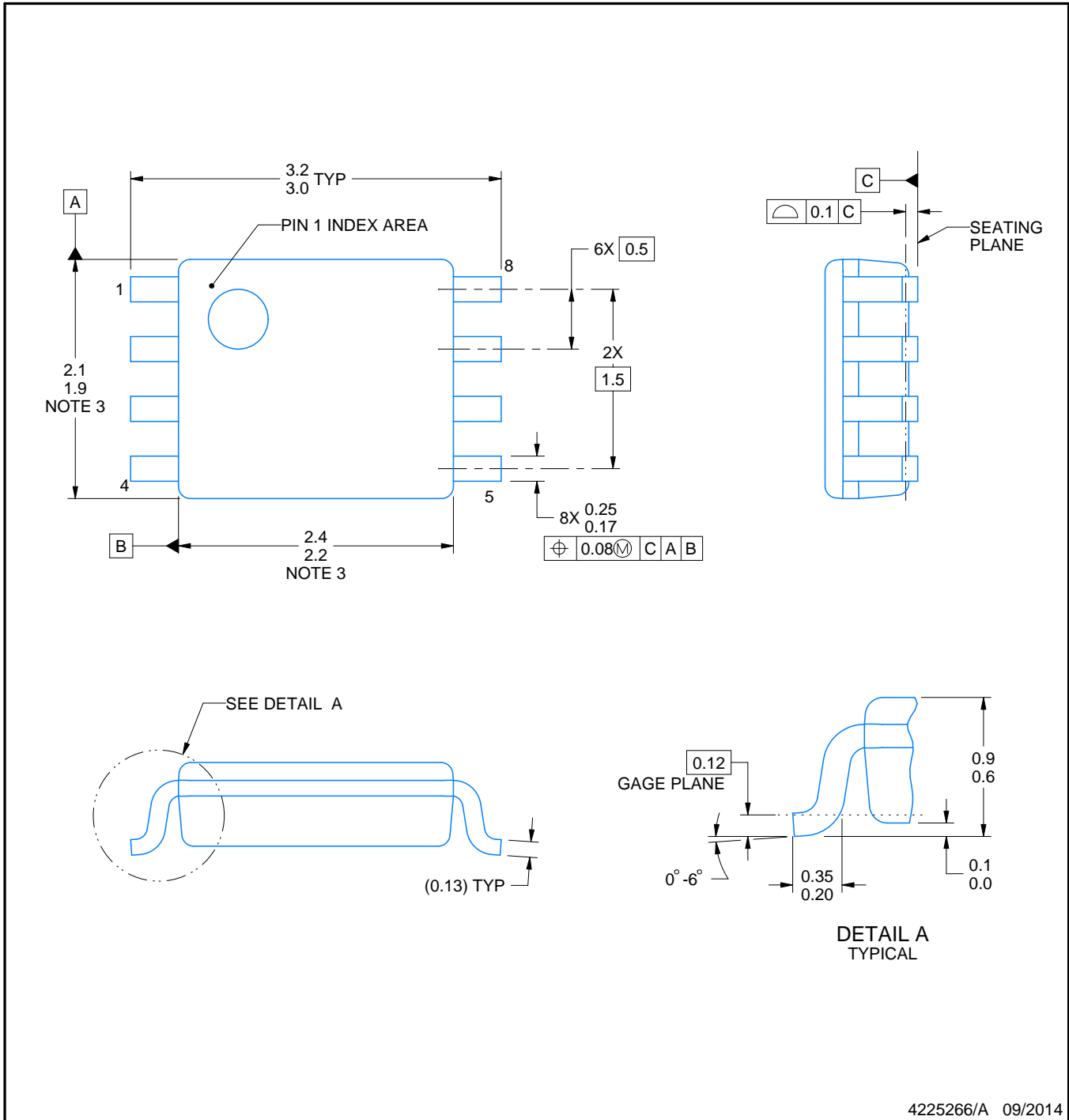
Device	Package Type	Package Drawing	Pins	SPQ	Length (mm)	Width (mm)	Height (mm)
SN74LVC1G74DCTR	SSOP	DCT	8	3000	190.0	190.0	30.0
SN74LVC1G74DCUR	VSSOP	DCU	8	3000	180.0	180.0	18.0
SN74LVC1G74DCURG4	VSSOP	DCU	8	3000	202.0	201.0	28.0
SN74LVC1G74DCUT	VSSOP	DCU	8	250	180.0	180.0	18.0
SN74LVC1G74DQER	X2SON	DQE	8	5000	184.0	184.0	19.0
SN74LVC1G74RSE2	UQFN	RSE	8	5000	184.0	184.0	19.0
SN74LVC1G74RSER	UQFN	RSE	8	5000	184.0	184.0	19.0



4225266/A 09/2014

NOTES:

1. All linear dimensions are in millimeters. Any dimensions in parenthesis are for reference only. Dimensioning and tolerancing per ASME Y14.5M.
2. This drawing is subject to change without notice.
3. This dimension does not include mold flash, protrusions, or gate burrs. Mold flash, protrusions, or gate burrs shall not exceed 0.15 mm per side.
4. Reference JEDEC registration MO-187 variation CA.

EXAMPLE BOARD LAYOUT

DCU0008A

VSSOP - 0.9 mm max height

SMALL OUTLINE PACKAGE

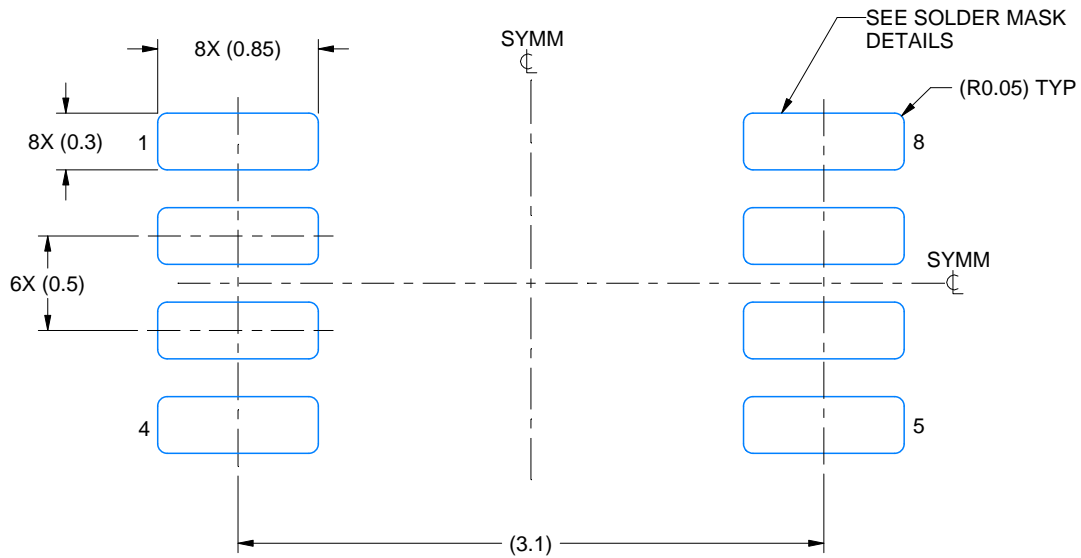

LAND PATTERN EXAMPLE
EXPOSED METAL SHOWN
SCALE: 25X

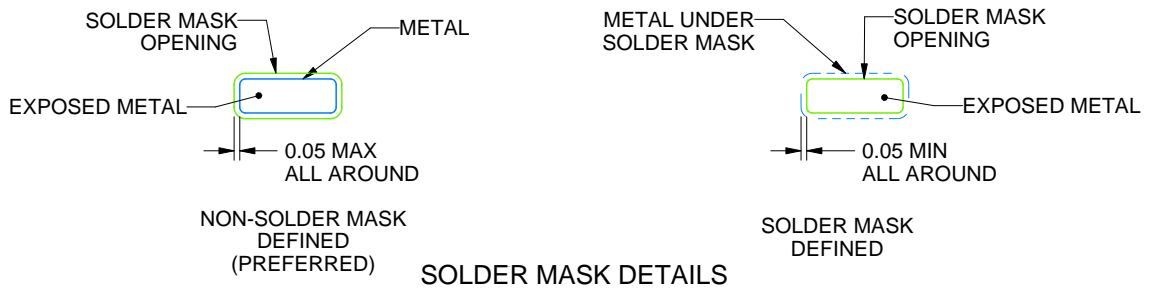

4225266/A 09/2014

NOTES: (continued)

- Publication IPC-7351 may have alternate designs.
- Solder mask tolerances between and around signal pads can vary based on board fabrication site.

EXAMPLE STENCIL DESIGN

DCU0008A

VSSOP - 0.9 mm max height

SMALL OUTLINE PACKAGE

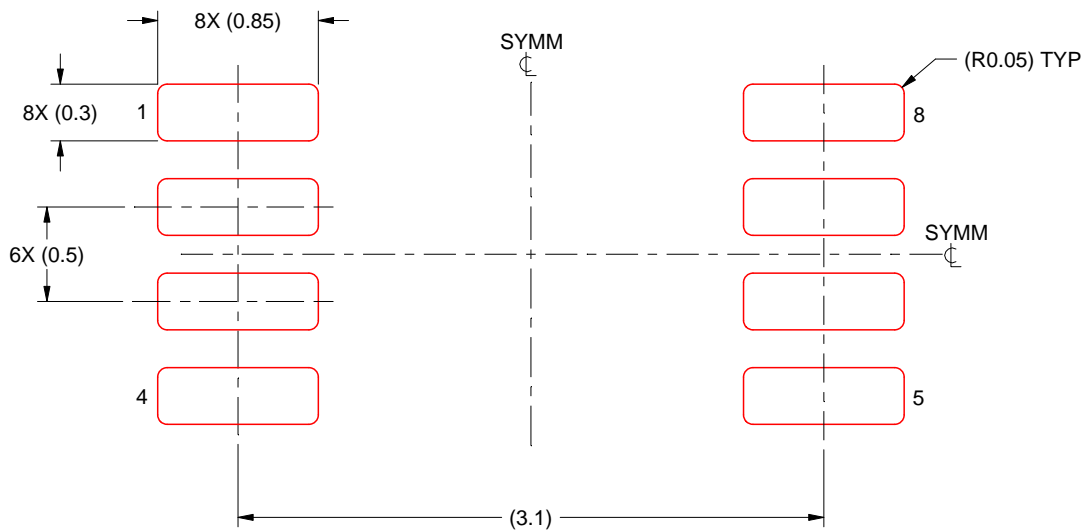

SOLDER PASTE EXAMPLE
BASED ON 0.125 mm THICK STENCIL
SCALE: 25X

4225266/A 09/2014

NOTES: (continued)

7. Laser cutting apertures with trapezoidal walls and rounded corners may offer better paste release. IPC-7525 may have alternate design recommendations.
8. Board assembly site may have different recommendations for stencil design.

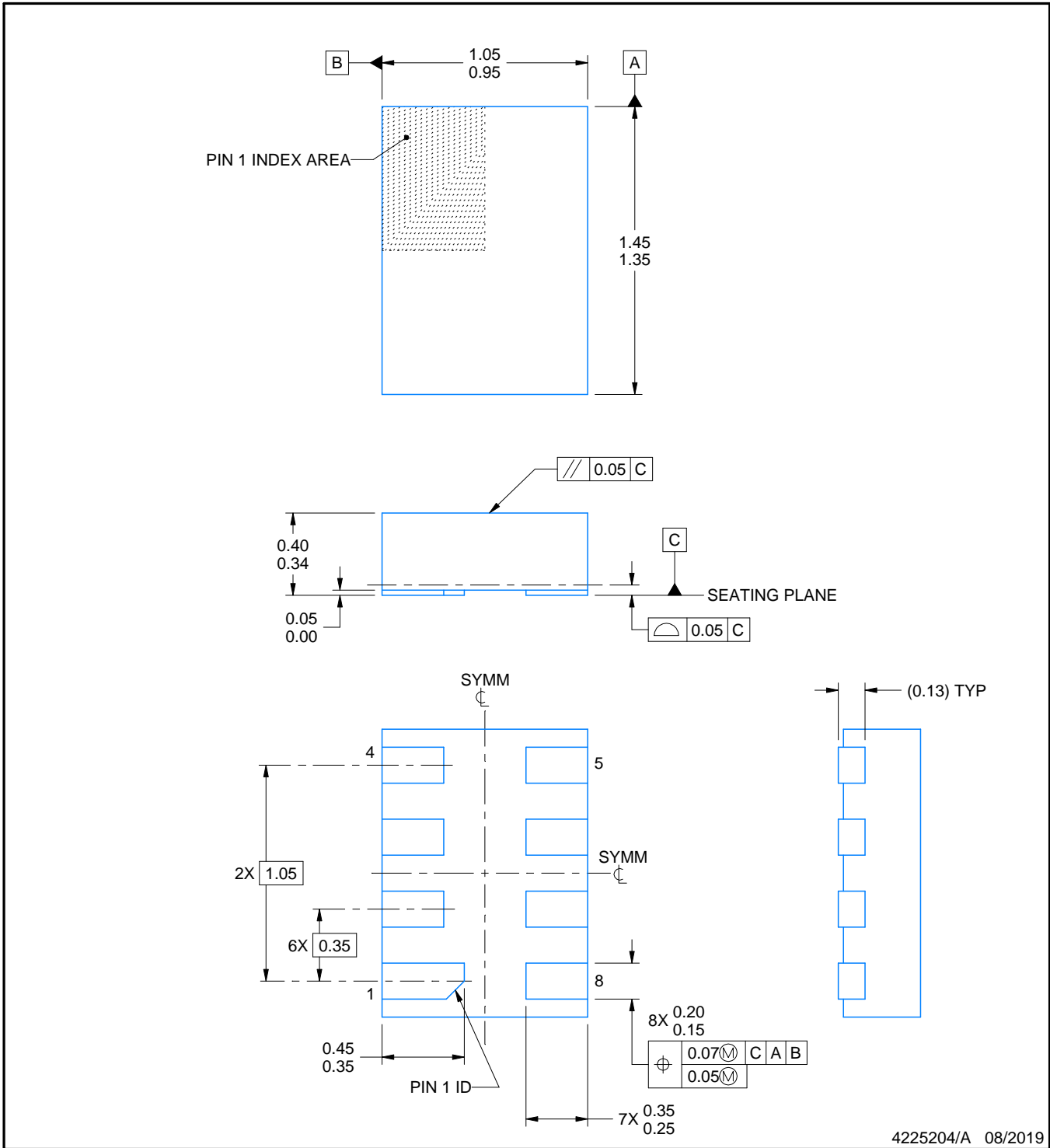
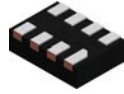

NOTES:

1. All linear dimensions are in millimeters. Any dimensions in parenthesis are for reference only. Dimensioning and tolerancing per ASME Y14.5M.
2. This drawing is subject to change without notice.
3. This package complies to JEDEC MO-287 variation X2EAF.

EXAMPLE BOARD LAYOUT

DQE0008A

X2SON - 0.4 mm max height

PLASTIC SMALL OUTLINE - NO LEAD

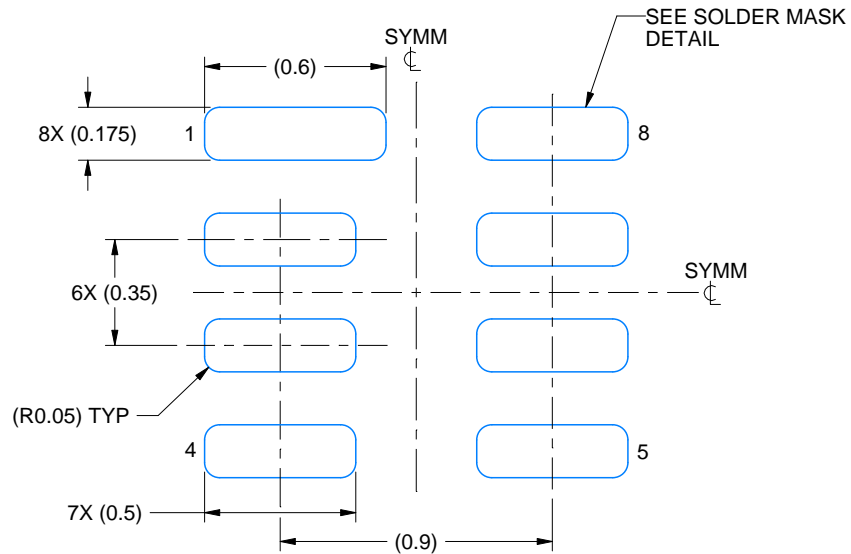

LAND PATTERN EXAMPLE
EXPOSED METAL SHOWN
SCALE: 40X

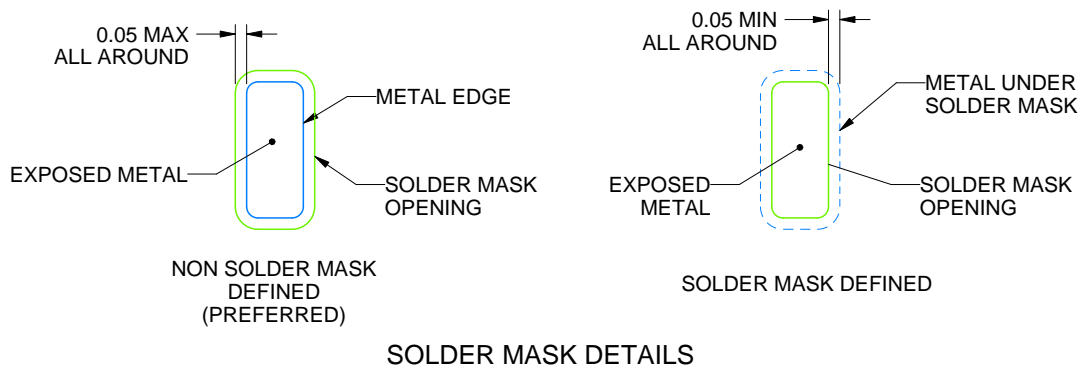

SOLDER MASK DETAILS

4225204/A 08/2019

NOTES: (continued)

4. This package is designed to be soldered to a thermal pad on the board. For more information, see Texas Instruments literature number SLUA271 (www.ti.com/lit/slua271).

EXAMPLE STENCIL DESIGN

DQE0008A

X2SON - 0.4 mm max height

PLASTIC SMALL OUTLINE - NO LEAD

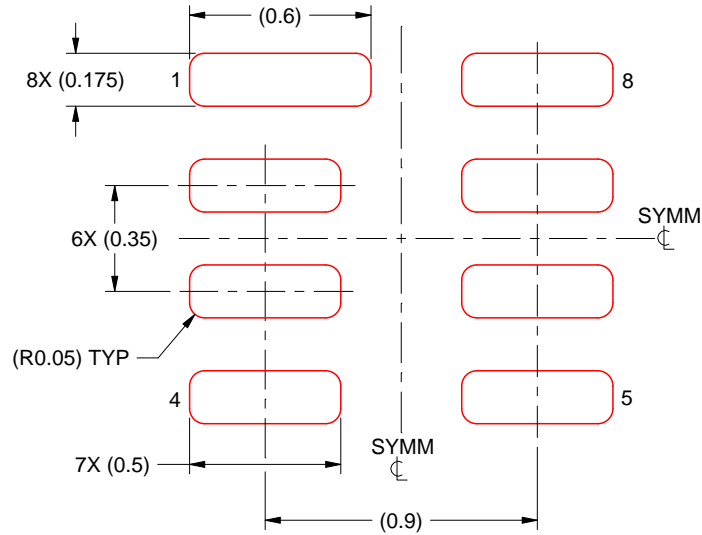

SOLDER PASTE EXAMPLE
BASED ON 0.075 MM THICK STENCIL
SCALE: 40X

4225204/A 08/2019

NOTES: (continued)

5. Laser cutting apertures with trapezoidal walls and rounded corners may offer better paste release. IPC-7525 may have alternate design recommendations.

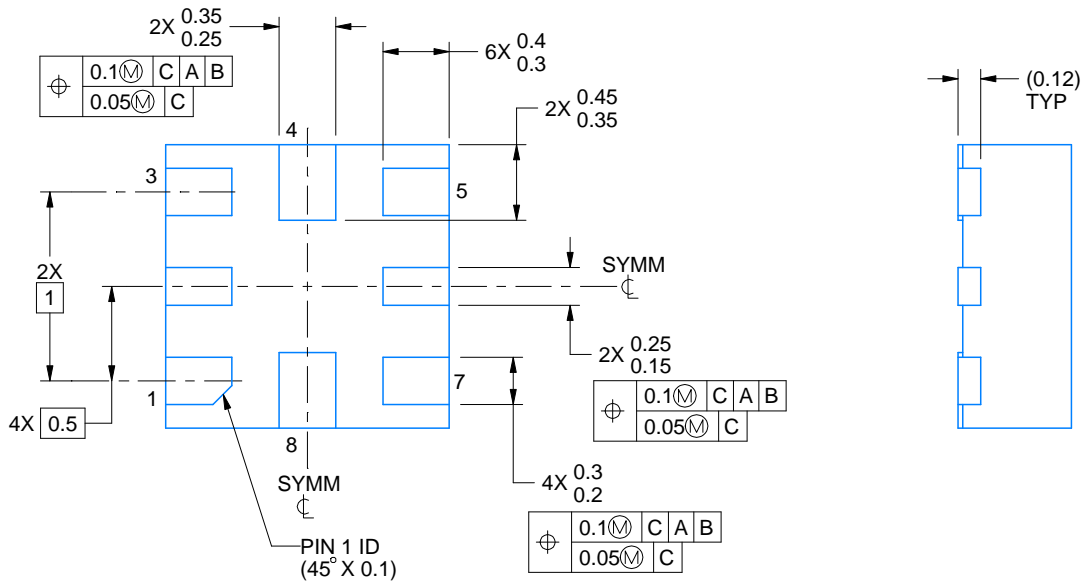
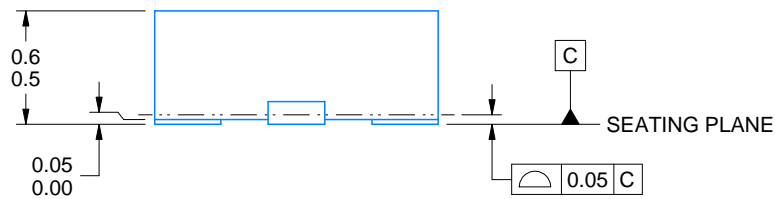
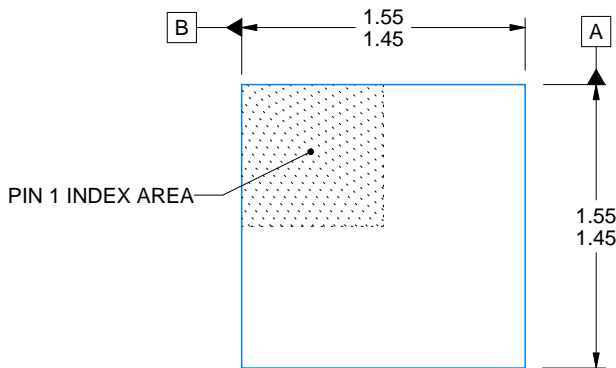
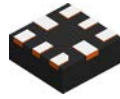

4220323/B 03/2018

NOTES:

1. All linear dimensions are in millimeters. Any dimensions in parenthesis are for reference only. Dimensioning and tolerancing per ASME Y14.5M.
2. This drawing is subject to change without notice.

EXAMPLE BOARD LAYOUT

RSE0008A

UQFN - 0.6 mm max height

PLASTIC QUAD FLATPACK - NO LEAD

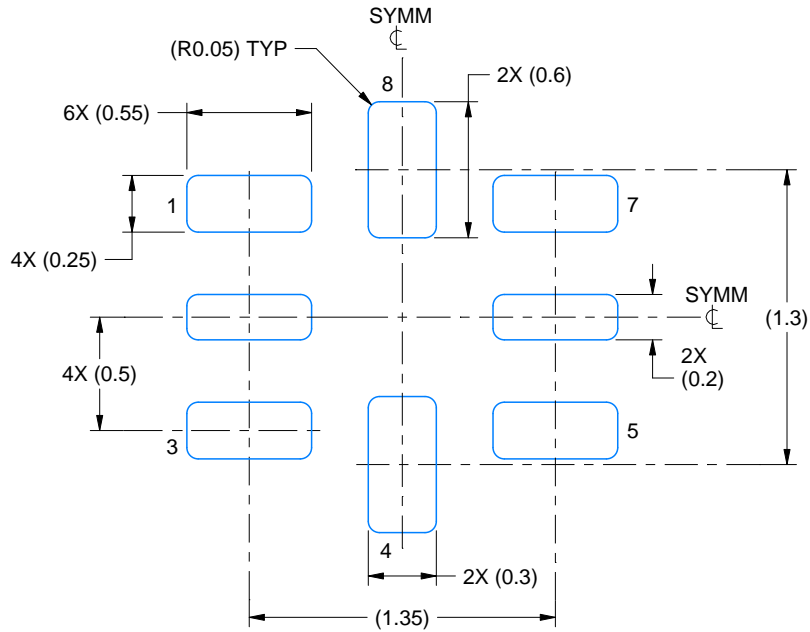

LAND PATTERN EXAMPLE
SCALE:30X

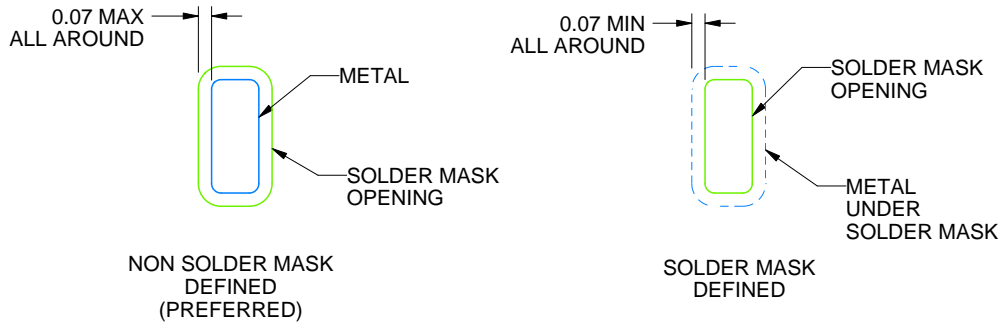

SOLDER MASK DETAILS
NOT TO SCALE

4220323/B 03/2018

NOTES: (continued)

3. For more information, see Texas Instruments literature number SLUA271 (www.ti.com/lit/slua271).

EXAMPLE STENCIL DESIGN

RSE0008A

UQFN - 0.6 mm max height

PLASTIC QUAD FLATPACK - NO LEAD

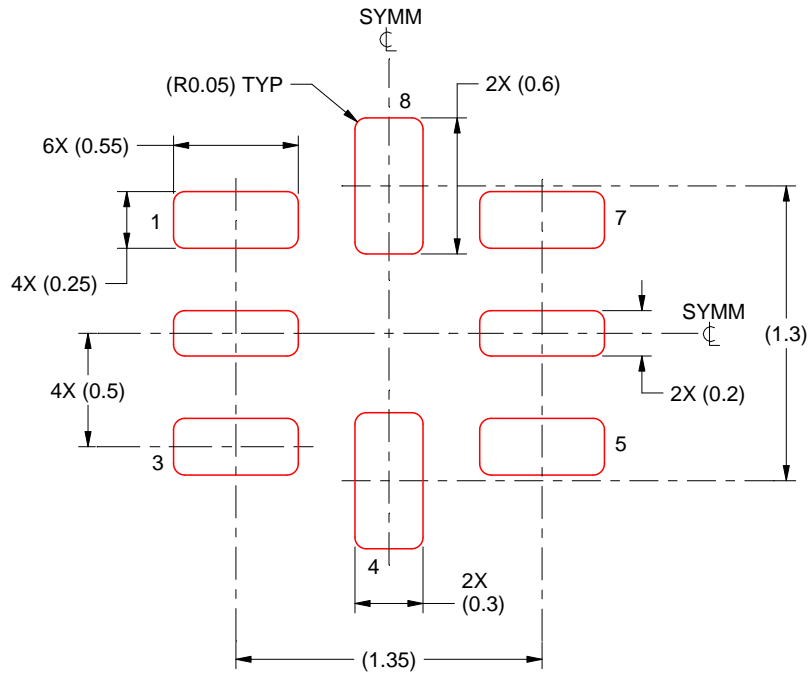

SOLDER PASTE EXAMPLE
BASED ON 0.1 mm THICKNESS
SCALE: 30X

4220323/B 03/2018

NOTES: (continued)

5. Laser cutting apertures with trapezoidal walls and rounded corners may offer better paste release. IPC-7525 may have alternate design recommendations.

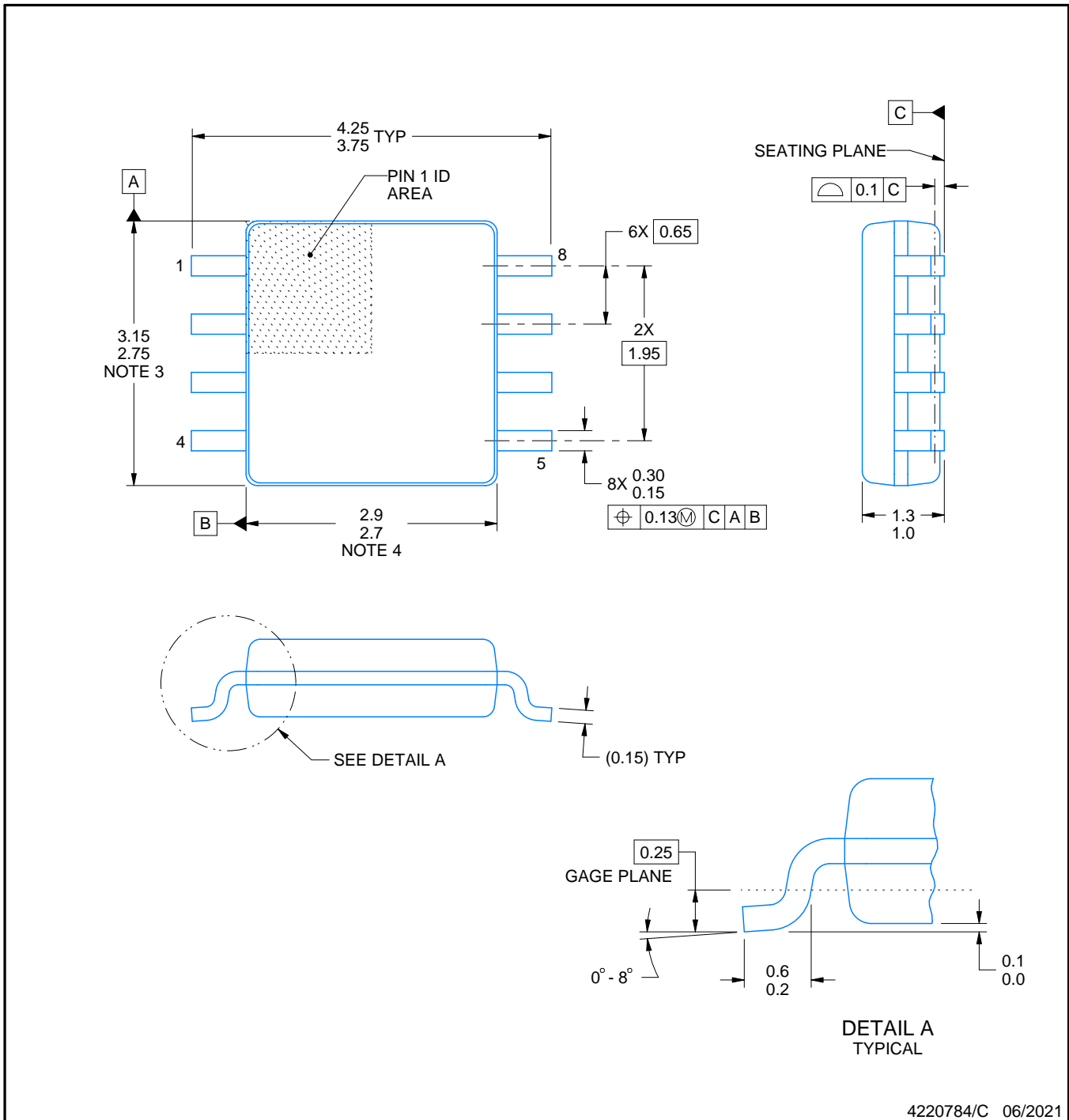
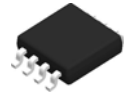

4220784/C 06/2021

NOTES:

- All linear dimensions are in millimeters. Dimensions in parenthesis are for reference only. Dimensioning and tolerancing per ASME Y14.5M.
- This drawing is subject to change without notice.
- This dimension does not include mold flash, protrusions, or gate burrs. Mold flash, protrusions, or gate burrs shall not exceed 0.15 mm per side.
- This dimension does not include interlead flash. Interlead flash shall not exceed 0.25 mm per side.

EXAMPLE BOARD LAYOUT

DCT0008A

SSOP - 1.3 mm max height

SMALL OUTLINE PACKAGE

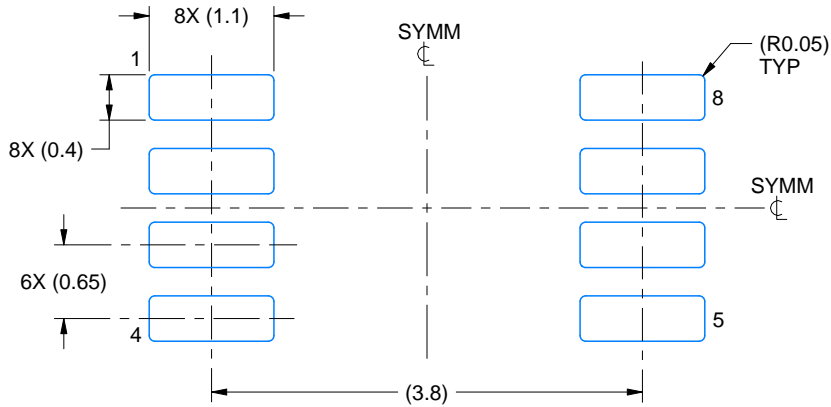

LAND PATTERN EXAMPLE
EXPOSED METAL SHOWN
SCALE:15X

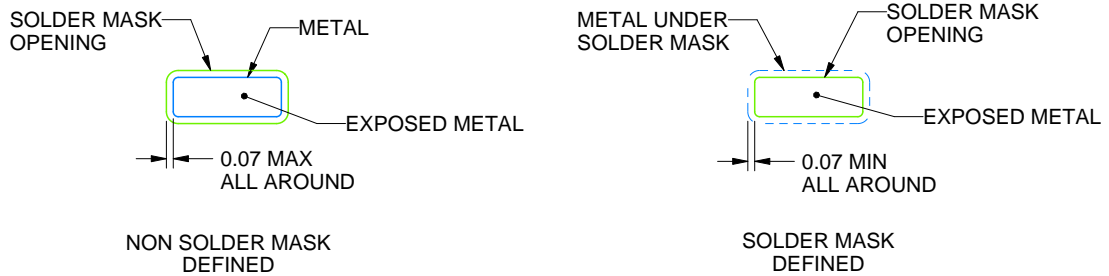

SOLDER MASK DETAILS

4220784/C 06/2021

NOTES: (continued)

- 5. Publication IPC-7351 may have alternate designs.
- 6. Solder mask tolerances between and around signal pads can vary based on board fabrication site.

EXAMPLE STENCIL DESIGN

DCT0008A

SSOP - 1.3 mm max height

SMALL OUTLINE PACKAGE

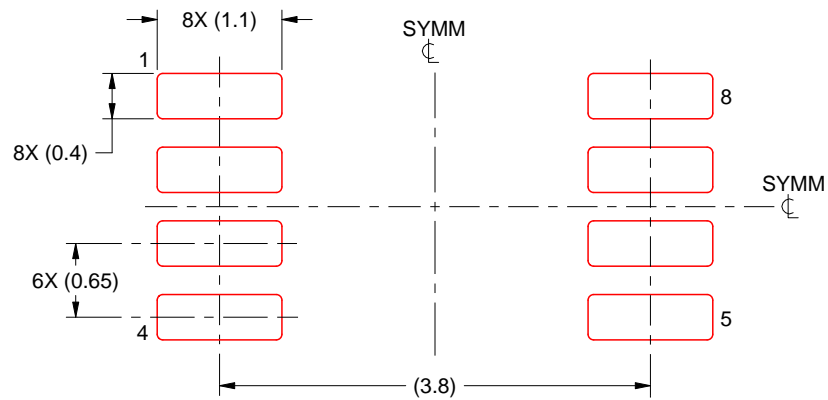

SOLDER PASTE EXAMPLE
BASED ON 0.125 mm THICK STENCIL
SCALE:15X

4220784/C 06/2021

NOTES: (continued)

7. Laser cutting apertures with trapezoidal walls and rounded corners may offer better paste release. IPC-7525 may have alternate design recommendations.
8. Board assembly site may have different recommendations for stencil design.

重要なお知らせと免責事項

テキサス・インスツルメンツは、技術データと信頼性データ(データシートを含みます)、設計リソース(リファレンス デザインを含みます)、アプリケーションや設計に関する各種アドバイス、Web ツール、安全性情報、その他のリソースを、欠陥が存在する可能性のある「現状のまま」提供しており、商品性および特定目的に対する適合性の黙示保証、第三者の知的財産権の非侵害保証を含むいかなる保証も、明示的または黙示的にかかわらず拒否します。

これらのリソースは、テキサス・インスツルメンツ製品を使用する設計の経験を積んだ開発者への提供を意図したものです。(1) お客様のアプリケーションに適したテキサス・インスツルメンツ製品の選定、(2) お客様のアプリケーションの設計、検証、試験、(3) お客様のアプリケーションに該当する各種規格や、その他のあらゆる安全性、セキュリティ、規制、または他の要件への確実な適合に関する責任を、お客様のみが単独で負うものとします。

上記の各種リソースは、予告なく変更される可能性があります。これらのリソースは、リソースで説明されているテキサス・インスツルメンツ製品を使用するアプリケーションの開発の目的でのみ、テキサス・インスツルメンツはその使用をお客様に許諾します。これらのリソースに関して、他の目的で複製することや掲載することは禁止されています。テキサス・インスツルメンツや第三者の知的財産権のライセンスが付与されている訳ではありません。お客様は、これらのリソースを自身で使用した結果発生するあらゆる申し立て、損害、費用、損失、責任について、テキサス・インスツルメンツおよびその代理人を完全に補償するものとし、テキサス・インスツルメンツは一切の責任を拒否します。

テキサス・インスツルメンツの製品は、[テキサス・インスツルメンツの販売条件](#)、または [ti.com](https://www.ti.com) やかかるテキサス・インスツルメンツ製品の関連資料などのいずれかを通じて提供する適用可能な条項の下で提供されています。テキサス・インスツルメンツがこれらのリソースを提供することは、適用されるテキサス・インスツルメンツの保証または他の保証の放棄の拡大や変更を意味するものではありません。

お客様がいかなる追加条項または代替条項を提案した場合でも、テキサス・インスツルメンツはそれらに異議を唱え、拒否します。

郵送先住所：Texas Instruments, Post Office Box 655303, Dallas, Texas 75265
Copyright © 2025, Texas Instruments Incorporated