

TCAN1043N-Q1 車載対応、スリープモード搭載、CAN FD トランシーバ

1 特長

- 車載アプリケーション用に AEC Q100 認定済み
- 機能安全対応
 - 機能安全システムの設計に役立つ資料を利用可能
- ISO 11898-2:2024 の要件に適合
- 広い動作入力電圧範囲
- 最大 8Mbps の classic CAN および CAN FD をサポート
- V_{IO} レベルシフト対応: 1.7V~5.5V
- 動作モード:
 - 通常モード
 - サイレントモード
 - スタンバイモード
 - 低消費電力スリープモード
- システム電源制御のための高電圧 INH 出力
- WAKE ピンによるローカル ウェイクアップのサポート
- 電源非接続時の規定された挙動
 - バスおよび入出力端子は高インピーダンス (動作中のバスまたはアプリケーションに対して無負荷)
- 保護機能:
 - CAN バスの障害耐性: $\pm 58V$
 - V_{SUP} でのロード ダンプのサポート
 - IEC ESD 保護
 - 低電圧保護
 - サーマル シャットダウン保護機能
 - TXD ドミナント状態タイムアウト (TXD DTO)
- 14 ピンのリード付き (SOT および SOIC) パッケージおよび自動光学検査 (AOI) 性能向上のためのウェットブル フランク付きリードレス (VSON) パッケージで供給

2 アプリケーション

- ボディエレクトロニクスおよび照明
- 車載ゲートウェイ
- 先進運転支援システム (ADAS)
- インフォテインメントおよびクラスタ
- ハイブリッド、電気、パワートレインシステム
- 個人用移動車両: 電動バイク
- 産業用輸送システム

3 概要

TCAN1043N-Q1 は、High-speed CAN (Controller Area Network) トランシーバであり、ISO 11898-2:2024 High-speed CAN 仕様の物理層要件を満足しています。このデバイスは、Classical CAN ネットワークと最高 8 メガビット/秒 (Mbps) の CAN FD ネットワークの両方に対応しています。

TCAN1043N-Q1 を使用すると、システムに存在する各種電源供給の有効無効を INH 出力ピンで切り替えることにより、バッテリーの消費電流をシステムレベルで低減できます。これにより、CAN バスを監視しながら、TCAN1043N-Q1 を除くすべてのシステムコンポーネントの電源が遮断される低電流スリープ状態を実現します。ウェイクアップイベントが検出された場合、TCAN1043N-Q1 は INH を High に駆動することでシステムの起動を開始します。

パッケージ情報

部品番号	パッケージ ⁽¹⁾	パッケージサイズ ⁽²⁾
TCAN1043N-Q1	SOT (DYY) ⁽³⁾	4.2 mm × 3.26mm
	SOIC (D) ⁽³⁾	8.65 mm × 6mm
	VSON (DMT)	4.5 mm × 3mm

- 詳細については、[セクション 11](#) を参照してください。
- パッケージサイズ (長さ × 幅) は公称値であり、該当する場合はピンも含まれます。
- 製品プレビュー

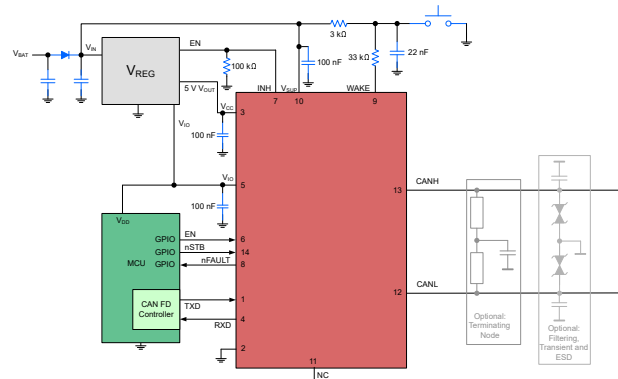

概略回路図



Table of Contents

1 特長	1	7.1 Overview.....	18
2 アプリケーション	1	7.2 Functional Block Diagram.....	18
3 概要	1	7.3 Feature Description.....	19
4 Pin Configuration and Functions	3	7.4 Device Functional Modes.....	26
5 Specifications	4	8 Application Information Disclaimer	35
5.1 Absolute Maximum Ratings.....	4	8.1 Application Information.....	35
5.2 ESD Ratings.....	4	8.2 Power Supply Recommendations.....	37
5.3 ESD Ratings - IEC Specifications.....	4	8.3 Layout.....	37
5.4 Recommended Operating Conditions.....	5	9 Device and Documentation Support	39
5.5 Thermal Information.....	5	9.1 Documentation Support.....	39
5.6 Power Dissipation Ratings.....	5	9.2 ドキュメントの更新通知を受け取る方法.....	39
5.7 Power Supply Characteristics.....	5	9.3 サポート・リソース.....	39
5.8 Electrical Characteristics.....	7	9.4 Trademarks.....	39
5.9 Timing Requirements.....	9	9.5 静電気放電に関する注意事項.....	39
5.10 Switching Characteristics.....	11	9.6 用語集.....	39
5.11 Typical Characteristics.....	13	10 Revision History	39
6 Parameter Measurement Information	14	11 Mechanical, Packaging, and Orderable Information	39
7 Detailed Description	18		

4 Pin Configuration and Functions

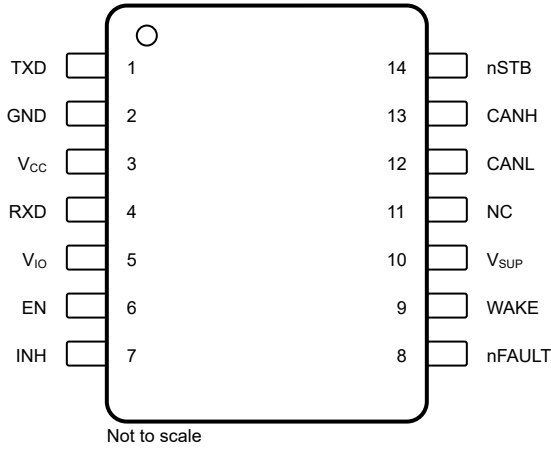

4-1. D and DYY Packages, 14 Pin (SOIC) and (SOT) (Top View)

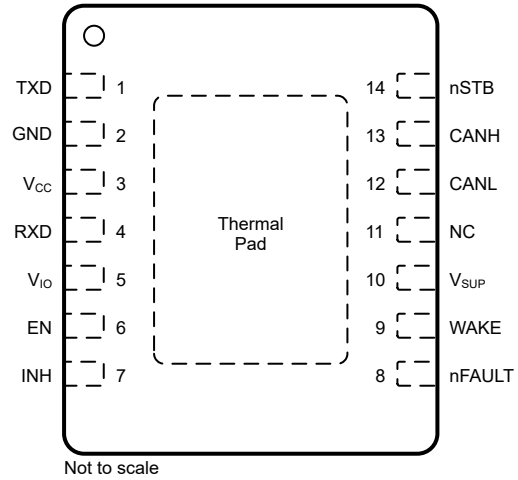

4-2. DMT Package, 14 Pin (VSON) (Top View)

PINS		TYPE (1)	DESCRIPTION
NAME	NO.		
TXD	1	I	CAN transmit data input, integrated pull-up
GND	2	GND	Ground connection
V _{CC}	3	P	5 V transceiver supply
RXD	4	O	CAN receive data output, tri-state when V _{IO} < UV _{IO}
V _{IO}	5	P	I/O supply voltage
EN	6	I	Enable input for mode control, integrated pull-down
INH	7	O	Inhibit pin to control system voltage regulators and supplies, high-voltage
nFAULT	8	O	Fault output, inverted logic
WAKE	9	I	Local WAKE input terminal, high voltage
V _{SUP}	10	P	High-voltage supply from battery
NC	11	NC	No connect, internally not connected
CANL	12	I/O	Low-level CAN bus input/output line
CANH	13	I/O	High-level CAN bus input/output line
nSTB	14	I	Standby mode control input, integrated pull-down
Thermal Pad		—	Connect the thermal pad to the printed circuit board (PCB) ground plane for thermal relief

(1) I = input, O = output, P = power, GND = ground, NC = not connected

5 Specifications

5.1 Absolute Maximum Ratings

over operating free-air temperature range (unless otherwise noted)⁽¹⁾

		MIN	MAX	UNIT
V _{SUP}	Supply voltage ⁽²⁾	-0.3	45	V
V _{CC}	Supply voltage	-0.3	6	V
V _{IO}	Supply voltage I/O level shifter	-0.3	6	V
V _{BUS}	CAN bus I/O voltage (CANH, CANL)	-58	58	V
V _{DIFF}	CAN bus differential voltage (V _{DIFF} = V _{CANH} - V _{CANL})	-58	58	V
V _{WAKE}	WAKE input voltage	-45	45 and V _I ≤ V _{SUP} +0.3	V
V _{INH}	INH pin voltage	-0.3	45 and V _O ≤ V _{SUP} +0.3	V
V _{LOGIC}	Logic pin voltage	-0.3	6	V
I _{O(LOGIC)}	Logic pin output current		8	mA
I _{O(INH)}	Inhibit pin output current		6	mA
I _{O(WAKE)}	WAKE pin output current		3	mA
T _J	Junction temperature	-40	165	°C
T _{STG}	Storage temperature	-65	150	°C

- (1) Operation outside the Absolute Maximum Ratings may cause permanent device damage. Absolute maximum ratings do not imply functional operation of the device at these or any other conditions beyond those listed under Recommended Operating Conditions. If briefly operating outside the Recommended Operating Conditions but within the Absolute Maximum Ratings, the device may not sustain damage, but it may not be fully functional. Operating the device in this manner may affect device reliability, functionality, performance, and shorten the device lifetime.
- (2) Able to support load dumps of up to 45 V for 300ms

5.2 ESD Ratings

			VALUE	UNIT	
V _{ESD}	Electrostatic discharge	Human body model (HBM), per AEC Q100-002 ⁽¹⁾	V _{SUP} , CANH, CANL, and WAKE with respect to ground	± 8000	V
			All pins except V _{SUP} , CANH, CANL, and WAKE	± 4000	V
		Charged device model (CDM), per AEC Q100-011	All pins	± 750	V

- (1) AEC Q100-002 indicates that HBM stressing shall be in accordance with the ANSI/ESDA/JEDEC JS-001 specification.

5.3 ESD Ratings - IEC Specifications

			VALUE	UNIT	
V _{ESD}	Electrostatic discharge	CANH, CANL, V _{SUP} , and WAKE terminal to GND	Unpowered Contact Discharge per ISO 10605 ⁽¹⁾	± 8000	V
V _{ESD}	Electrostatic discharge	CANH and CANL terminal to GND	SAE J2962-2 per ISO 10605 Powered Contact Discharge ⁽²⁾	± 8000	V
V _{ESD}	Electrostatic discharge	CANH and CANL terminal to GND	SAE J2962-2 per ISO 10605 Powered Air discharge ⁽²⁾	± 15000	V
V _{TRAN}	Transient voltage per ISO-7637-2 ⁽¹⁾	CAN, V _{SUP} , WAKE terminal to GND	Pulse 1	- 100	V
			Pulse 2	75	V
			Pulse 3a	- 150	V
			Pulse 3b	100	V
	Transient voltage per ISO-7637-3 ⁽²⁾	CAN terminal to GND	Direct coupling capacitor "slow transient pulse" with 100 nF coupling capacitor - powered	± 30	V

- (1) Results given here are specific to the IEC 62228-3 Integrated circuits – EMC evaluation of transceivers – Part 3: CAN transceivers. Testing performed by IBEE Zwickau, EMC report available upon request.

- (2) Results given here are specific to the SAE J2962-2 Communication Transceivers Qualification Requirements - CAN. Testing performed by OEM-approved independent 3rd party, EMC report available upon request.

5.4 Recommended Operating Conditions

over operating free-air temperature range (unless otherwise noted)

		MIN	NOM	MAX	UNIT
V _{SUP}	Supply voltage	4.5		40	V
V _{IO}	I/O supply voltage	1.7		5.5	V
V _{CC}	CAN transceiver supply voltage	4.5		5.5	V
I _{OH(DO)}	Digital output high-level current	-2			mA
I _{OL(DO)}	Digital output low-level current			2	mA
I _{O(INH)}	Inhibit output current			1	mA
T _J	Operating junction temperature	-40		150	°C
T _{SDR}	Thermal shutdown	175			°C
T _{SDF}	Thermal shutdown release	160			°C
T _{SD(HYS)}	Thermal shutdown hysteresis		10		°C

5.5 Thermal Information

THERMAL METRIC ⁽¹⁾		TCAN1043N-Q1			UNIT
		D (SOIC)	DMT (VSON)	DYY (SOT)	
		14 PINS	14 PINS	14 PINS	
R _{θJA}	Junction-to-ambient thermal resistance	87.1	39.7	91.0	°C/W
R _{θJC(top)}	Junction-to-case (top) thermal resistance	41.8	41.1	41.7	°C/W
R _{θJB}	Junction-to-board thermal resistance	43.7	15.9	25.6	°C/W
Ψ _{JT}	Junction-to-top characterization parameter	8.5	0.9	25.4	°C/W
Ψ _{JB}	Junction-to-board characterization parameter	43.3	15.9	1.1	°C/W
R _{θJC(bot)}	Junction-to-case (bottom) thermal resistance	N/A	6.6	N/A	°C/W

- (1) For more information about traditional and new thermal metrics, see the [Semiconductor and IC Package Thermal Metrics](#) application report.

5.6 Power Dissipation Ratings

PARAMETER		TEST CONDITIONS	POWER DISSIPATION	UNIT
P _D	Average power dissipation	V _{SUP} = 14 V, V _{CC} = 5 V, V _{IO} = 5 V, T _J = 27°C, R _L = 60 Ω, nSTB = 5 V, EN = 5 V, C _{L_RXD} = 15 pF. Typical CAN operating conditions at 500 kbps with 25% transmission (dominant) rate.	65	mW
		V _{SUP} = 14 V, V _{CC} = 5.5 V, V _{IO} = 5.5 V, T _J = 150°C, R _L = 50 Ω, nSTB = 5.5 V, EN = 5.5 V, C _{L_RXD} = 15 pF. Typical high load CAN operating conditions at 1 Mbps with 50% transmission (dominant) rate and loaded network.	140	mW

5.7 Power Supply Characteristics

Over recommended operating conditions with T_J = -40°C to 150°C, unless otherwise noted. All typical values are taken at 25°C, V_{SUP} = 12 V, V_{IO} = 3.3 V, V_{CC} = 5 V and R_L = 60 Ω

PARAMETER		TEST CONDITIONS	MIN	TYP	MAX	UNIT
Supply Voltage and Current Characteristics						
I _{SUP_NORMAL}	Supply current CAN active	Normal mode, silent mode, and go-to-sleep mode			140	μA
I _{SUP_STBY-85C}	Supply current, Standby mode CAN autonomous: inactive ⁽²⁾	V _{SUP} = 12V, T _J = -40 °C to 85 °C ⁽³⁾		27	33	μA
I _{SUP_STBY}	Supply current, Standby mode CAN autonomous: inactive ⁽²⁾				60	μA

5.7 Power Supply Characteristics (続き)

Over recommended operating conditions with $T_J = -40^\circ\text{C}$ to 150°C , unless otherwise noted. All typical values are taken at 25°C , $V_{\text{SUP}} = 12\text{ V}$, $V_{\text{IO}} = 3.3\text{ V}$, $V_{\text{CC}} = 5\text{ V}$ and $R_L = 60\ \Omega$

PARAMETER		TEST CONDITIONS	MIN	TYP	MAX	UNIT
$I_{\text{SUP_SLEEP-85C}}$	Supply current, Sleep mode CAN autonomous: inactive (2)	$T_J = -40^\circ\text{C}$ to 85°C $V_{\text{SUP}} = 12\text{ V}$ (3)		23	26	μA
$I_{\text{SUP_SLEEP}}$	Supply current, Sleep mode CAN autonomous: inactive (2)			23	30	μA
$I_{\text{SUP_BIAS}}$	Additional supply current when in CAN autonomous: active ($I_{\text{SUP(BIAS)}}$)	$5.5\text{ V} < V_{\text{SUP}} \leq 28\text{ V}$ (1)			60	μA
$UV_{\text{SUP(R)}}$	Undervoltage V_{SUP} threshold rising		3.85		4.4	V
$UV_{\text{SUP(F)}}$	Undervoltage V_{SUP} threshold falling		3.5		4.25	V
$I_{\text{CC_NORMAL}}$	Supply current CAN active: dominant	Normal mode TXD = 0 V, $R_L = 60\ \Omega$, $C_L = \text{open}$			60	mA
		Normal mode TXD = 0 V, $R_L = 50\ \Omega$, $C_L = \text{open}$			70	mA
	V_{CC} supply current normal mode Dominant with bus fault	Normal mode TXD = 0 V, $R_L = \text{open}$, $C_L = \text{open}$, CANH = -25 V			110	mA
	Supply current CAN active: recessive	Normal mode TXD = V_{IO} , $R_L = 50\ \Omega$, $C_L = \text{open}$			5	mA
$I_{\text{CC_STBY}}$	Supply current, Standby mode CAN autonomous: inactive	$T_J = -40^\circ\text{C}$ to 85°C (3) EN = nSTB = 0 V			2	μA
		Standby mode EN = nSTB = 0 V			5	μA
$I_{\text{CC_SILENT}}$	Supply current, Silent and go-to-sleep mode	Silent and go-to-sleep mode TXD = nSTB = V_{IO} , $R_L = 50\ \Omega$, $C_L = \text{open}$			3	mA
$I_{\text{CC_SLEEP}}$	Supply current, Sleep mode CAN autonomous: inactive	Sleep mode $T_J = -40^\circ\text{C}$ to 85°C (3) EN = 0 V or V_{IO} , nSTB = 0 V			2	μA
		Sleep mode EN = 0 V or V_{IO} , nSTB = 0 V			5	μA
$UV_{\text{CC(R)}}$	Undervoltage V_{CC} threshold rising			4.1	4.4	V
$UV_{\text{CC(F)}}$	Undervoltage V_{CC} threshold falling		3.5	3.9		V
$V_{\text{HYS(UVCC)}}$	Hysteresis voltage on UV_{CC}		50	240	320	mV
$I_{\text{IO_NORMAL}}$	I/O supply current	Normal mode RXD floating, TXD = 0 V			200	μA
	I/O supply current	Normal mode, standby mode, or go-to-sleep mode RXD floating, TXD = V_{IO}			5	μA
$I_{\text{IO_SLEEP}}$	I/O supply current	Sleep mode $T_J = -40^\circ\text{C}$ to 85°C (3) nSTB = 0 V			2.5	μA
	I/O supply current	Sleep mode nSTB = 0 V			5	μA
$UV_{\text{IO(R)}}$	Under voltage V_{IO} threshold rising	Ramp up		1.4	1.65	V
$UV_{\text{IO(F)}}$	Under voltage V_{IO} threshold falling	Ramp down	1	1.25		V
$V_{\text{HYS(UVIO)}}$	Hysteresis voltage on UV_{IO}		30	60	160	mV

- (1) $I_{\text{SUP(BIAS)}}$ is calculated by subtracting the supply current in CAN autonomous inactive mode from the total supply current in CAN autonomous active mode
- (2) After a valid wake-up, the CAN transceiver switches to CAN autonomous active mode and the $I_{\text{SUP(BIAS)}}$ current needs to be added to the specified I_{SUP} current in CAN autonomous inactive mode.
- (3) Specified by design and verified via bench characterization

5.8 Electrical Characteristics

Over recommended operating conditions with $T_J = -40^{\circ}\text{C}$ to 150°C , unless otherwise noted. All typical values are taken at 25°C , $V_{\text{SUP}} = 12\text{ V}$, $V_{\text{IO}} = 3.3\text{ V}$, $V_{\text{CC}} = 5\text{ V}$ and $R_L = 60\ \Omega$

PARAMETER		TEST CONDITIONS		MIN	TYP	MAX	UNIT
CAN Driver Characteristics							
$V_{\text{CANH(D)}}$	Dominant output voltage Bus biasing active	CANH	TXD = 0 V, $50 \leq R_L \leq 65\ \Omega$, $C_L = \text{open}$, $R_{\text{CM}} = \text{open}$	2.75		4.5	V
		CANL	See 6-1 and 6-4	0.5		2.25	V
$V_{\text{CANH(R)}}$ $V_{\text{CANL(R)}}$	Recessive output voltage Bus biasing active, terminated	Recessive output voltage Bus biasing active, terminated	TXD = V_{IO} , $R_L = 60\ \Omega$, $R_{\text{CM}} = \text{open}$ See 6-1 and 6-4	2.137		2.887	V
$V_{\text{CANH(R)}}$ $V_{\text{CANL(R)}}$	Recessive output voltage Bus biasing active		TXD = V_{IO} , $R_L = \text{open}$ (no load), $R_{\text{CM}} = \text{open}$ See 6-1 and 6-4	2		3	V
V_{SYM}	Driver symmetry Bus biasing active $(V_{\text{O(CANH)}} + V_{\text{O(CANL)}}) / V_{\text{CC}}$		nSTB = V_{IO} , $R_L = 60\ \Omega$, $C_{\text{SPLIT}} = 4.7\text{ nF}$, $C_L = \text{Open}$, $R_{\text{CM}} = \text{Open}$, TXD = 250 kHz, 1 MHz, 2.5 MHz See 6-1 and 6-4	0.9		1.1	V/V
$V_{\text{SYM_DC}}$	DC Driver symmetry Bus biasing active $V_{\text{CC}} - V_{\text{O(CANH)}} - V_{\text{O(CANL)}}$		nSTB = V_{IO} , $R_L = 60\ \Omega$, $C_L = \text{open}$ See 6-1 and 6-4	-400		400	mV
$V_{\text{DIFF(D)}}$	Differential output voltage Bus biasing active Dominant	CANH - CANL	nSTB = V_{IO} , TXD = 0 V, $50\ \Omega \leq R_L \leq 65\ \Omega$, $C_L = \text{open}$ See 6-1 and 6-4	1.5		3	V
		CANH - CANL	nSTB = V_{IO} , TXD = 0 V, $45\ \Omega \leq R_L \leq 70\ \Omega$, $C_L = \text{open}$ See 6-1 and 6-4	1.4		3.3	V
		CANH - CANL	nSTB = V_{IO} , TXD = 0 V, $R_L = 2240\ \Omega$, $C_L = \text{open}$ See 6-1 and 6-4	1.5		5	V
$V_{\text{DIFF(R)}}$	Differential output voltage Bus biasing active Recessive	CANH - CANL	nSTB = V_{IO} , TXD = V_{IO} , $R_L = \text{open}\ \Omega$, $C_L = \text{open}$ See 6-1 and 6-4	-50		50	mV
$V_{\text{CANH(INACT)}}$	Bus output voltage with bus biasing inactive	CANH	nSTB = 0 V, TXD = V_{IO} , $R_L = \text{open}$ (no load), $C_L = \text{open}$ See 6-1 and 6-4	-0.1		0.1	V
		CANL	nSTB = 0 V, TXD = V_{IO} , $R_L = \text{open}$ (no load), $C_L = \text{open}$ See 6-1 and 6-4	-0.1		0.1	V
		CANH - CANL	nSTB = 0 V, TXD = V_{IO} , $R_L = \text{open}$ (no load), $C_L = \text{open}$ See 6-1 and 6-4	-0.2		0.2	V
$I_{\text{CANL(OS)}}$	Short-circuit steady-state output current Bus biasing active Dominant		nSTB = V_{IO} , TXD = 0 V $-15\text{ V} \leq V_{\text{(CANH)}} \leq 40\text{ V}$ See 6-1 and 6-8	-100			mA
			nSTB = V_{IO} , TXD = 0 V $-15\text{ V} \leq V_{\text{(CANL)}} \leq 40\text{ V}$ See 6-1 and 6-8			100	mA
$I_{\text{OS(REC)}}$	Short-circuit steady-state output current Bus biasing active Recessive		nSTB = V_{IO} , $V_{\text{BUS}} = \text{CANH} = \text{CANL}$ $-27\text{ V} \leq V_{\text{BUS}} \leq 42\text{ V}$ See 6-1 and 6-8	-3		3	mA
CAN Receiver Characteristics							
$V_{\text{IT(DOM)}}$	Receiver dominant state input voltage range Bus biasing active		nSTB = V_{IO} , $-12\text{ V} \leq V_{\text{CM}} \leq 12\text{ V}$ See 6-5 and 7-6	0.9		8	V
$V_{\text{IT(REC)}}$	Receiver recessive state input voltage range Bus biasing active			-3		0.5	V
V_{HYS}	Hysteresis voltage for input threshold Bus biasing active		nSTB = V_{IO} See 6-5 and 7-6		140		mV

5.8 Electrical Characteristics (続き)

Over recommended operating conditions with $T_J = -40^\circ\text{C}$ to 150°C , unless otherwise noted. All typical values are taken at 25°C , $V_{\text{SUP}} = 12\text{ V}$, $V_{\text{IO}} = 3.3\text{ V}$, $V_{\text{CC}} = 5\text{ V}$ and $R_L = 60\ \Omega$

PARAMETER		TEST CONDITIONS	MIN	TYP	MAX	UNIT
$V_{\text{DIFF(DOM)}}$	Receiver dominant state input voltage range Bus biasing inactive	$n\text{STB} = 0\text{ V}$, $-12\text{ V} \leq V_{\text{CM}} \leq 12\text{ V}$ See 図 6-5 and 表 7-6	1.150		8	V
$V_{\text{DIFF(REC)}}$	Receiver recessive state input voltage range Bus biasing inactive		-3		0.4	V
V_{CM}	Common mode range	$n\text{STB} = V_{\text{IO}}$ See 図 6-5 and 表 7-6	-12		12	V
$I_{\text{OFF(LKG)}}$	Power-off (unpowered) input leakage current CANH, CANL pins	$V_{\text{SUP}} = 0\text{ V}$, $\text{CANH} = \text{CANL} = 5\text{ V}$			4.5	μA
C_1	Input capacitance to ground (CANH or CANL) (1)				20	pF
C_{ID}	Differential input capacitance (1)				10	pF
R_{ID}	Differential input resistance	$\text{TXD} = V_{\text{CC}} = V_{\text{IO}} = 5\text{ V}$, $n\text{STB} = 5\text{ V}$ $-12\text{ V} \leq V_{\text{CM}} \leq 12\text{ V}$	50		100	k Ω
R_{IN}	Input resistance (CANH or CANL)		25		50	k Ω
$R_{\text{IN(M)}}$	Input resistance matching: [1 - $R_{\text{IN(CANH)}} / R_{\text{IN(CANL)}}$] \times 100%	$V_{\text{(CANH)}} = V_{\text{(CANL)}} = 5\text{ V}$	-1		1	%
R_{CBF}	Valid differential load impedance range for bus fault circuitry	$R_{\text{CM}} = R_L$, $C_L = \text{open}$	45		70	Ω
TXD Characteristics						
V_{IH}	High-level input voltage		0.7			V_{IO}
V_{IL}	Low-level input voltage				0.3	V_{IO}
I_{IH}	High-level input leakage current	$\text{TXD} = V_{\text{IO}} = 5.5\text{ V}$	-2.5	0	1	μA
I_{IL}	Low-level input leakage current	$\text{TXD} = 0\text{ V}$, $V_{\text{IO}} = 5.5\text{ V}$	-137		-2.5	μA
$I_{\text{LKG(OFF)}}$	Unpowered leakage current	$\text{TXD} = 5.5\text{ V}$, $V_{\text{SUP}} = V_{\text{IO}} = 0\text{ V}$	-1	0	1	μA
R_{PU}	Pull-up resistance to V_{IO}		40	60	80	k Ω
C_1	Input Capacitance	$V_{\text{IN}} = 0.4 \times \sin(2 \times \pi \times 2 \times 10^6 \times t) + 2.5\text{ V}$		5		pF
RXD Characteristics						
V_{OH}	High-level output voltage	High-level output voltage $I_O = -1.5\text{ mA}$, $V_{\text{IO}} = 1.7\text{ V}$ See 図 6-5	0.8			V_{IO}
V_{OH}	High-level output voltage	$I_O = -2\text{ mA}$, $V_{\text{IO}} \geq 2.5\text{ V}$ See 図 6-5	0.8			V_{IO}
V_{OL}	Low-level output voltage	$I_O = 2\text{ mA}$ See 図 6-5			0.2	V_{IO}
$I_{\text{LKG(OFF)}}$	Unpowered leakage current	$\text{RXD} = 5.5\text{ V}$, $V_{\text{SUP}} = V_{\text{IO}} = 0\text{ V}$	-1		1	μA
nSTB Characteristics						
V_{IH}	High-level input voltage		0.7			V_{IO}
V_{IL}	Low-level input voltage				0.3	V_{IO}
I_{IH}	High-level input leakage current	$n\text{STB} = V_{\text{IO}} = 5.5\text{ V}$	0.5		137	μA
I_{IL}	Low-level input leakage current	$n\text{STB} = 0\text{ V}$, $V_{\text{IO}} = 5.5\text{ V}$	-1		1	μA
$I_{\text{LKG(OFF)}}$	Unpowered leakage current	$n\text{STB} = 5.5\text{ V}$, $V_{\text{IO}} = 0\text{ V}$	-1	0	1	μA
R_{PD}	Pull-down resistance		40	60	80	k Ω
nFAULT Characteristics						
V_{OH}	High-level output voltage	$I_O = -2\text{ mA}$	0.8			V_{IO}
V_{OL}	Low-level output voltage	$I_O = 2\text{ mA}$			0.2	V_{IO}
$I_{\text{LKG(OFF)}}$	Unpowered leakage current	$n\text{FAULT} = 5.5\text{ V}$, $V_{\text{IO}} = 0\text{ V}$	-1	0	1	μA
EN Characteristics						
V_{IH}	High-level input voltage		0.7			V_{IO}
V_{IL}	Low-level input voltage				0.3	V_{IO}
I_{IH}	High-level input leakage current	$\text{EN} = V_{\text{CC}} = V_{\text{IO}} = 5.5\text{ V}$	0.5		137	μA

5.8 Electrical Characteristics (続き)

Over recommended operating conditions with $T_J = -40^{\circ}\text{C}$ to 150°C , unless otherwise noted. All typical values are taken at 25°C , $V_{\text{SUP}} = 12\text{ V}$, $V_{\text{IO}} = 3.3\text{ V}$, $V_{\text{CC}} = 5\text{ V}$ and $R_L = 60\ \Omega$

PARAMETER		TEST CONDITIONS	MIN	TYP	MAX	UNIT
I_{IL}	Low-level input leakage current	EN = 0 V, $V_{\text{CC}} = V_{\text{IO}} = 5.5\text{ V}$	-1		1	μA
$I_{\text{LKG(OFF)}}$	Unpowered leakage current	EN = 5.5 V, $V_{\text{CC}} = V_{\text{IO}} = 0\text{ V}$	-1		1	μA
R_{PD}	Pull-down resistance		40	60	80	k Ω
WAKE Characteristics						
V_{IH}	High-level input voltage	Sleep mode	$V_{\text{SUP}} - 2$			V
V_{IL}	Low-level input voltage			$V_{\text{SUP}} - 3.5$		V
I_{IH}	High-level input leakage current ⁽²⁾	WAKE = $V_{\text{SUP}} - 1\text{ V}$	-3			μA
I_{IL}	Low-level input leakage current ⁽²⁾	WAKE = 1 V			3	μA
INH Characteristics						
ΔV_{H}	High-level voltage drop from V_{SUP} to INH ($V_{\text{SUP}} - V_{\text{INH}}$)	$I_{\text{INH}} = -6\text{ mA}$		0.5	1	V
$I_{\text{LKG(INH)}}$	Sleep mode leakage current	INH = 0 V	-0.5		0.5	μA
R_{PD}	Pull-down resistance	Sleep mode	2.5	4	6	M Ω

- (1) Specified by design and verified via bench characterization
(2) To minimize system level current consumption, the WAKE pin will automatically configure itself based on the applied voltage to either an internal pull-up or pull-down current source. A high-level input results in an internal pull-up and a low-level input results in an internal pull-down.

5.9 Timing Requirements

over operating free-air temperature range (unless otherwise noted)

PARAMETER		TEST CONDITIONS	MIN	TYP	MAX	UNIT
Supply Characteristics						
t_{PWRUP}	Time required for INH active after $V_{\text{SUP}} \geq UV_{\text{SUP(R)}}$	See 6-10		500		μs
t_{UV}	Undervoltage filter time V_{CC} and V_{IO} ⁽¹⁾	$V_{\text{CC}} \leq UV_{\text{CC}}$ or $V_{\text{IO}} \leq UV_{\text{IO}}$	100		350	ms
$t_{\text{UV(RE-ENABLE)}}$	Re-enable time after undervoltage event ⁽¹⁾	Time for device to return to normal operation from a UV_{CC} or UV_{IO} undervoltage event			200	μs
Device Characteristics						
$t_{\text{PROP(LOOP1)}}$	Total loop delay, driver input (TXD) to receiver output (RXD) Recessive to dominant	$R_L = 60\ \Omega$, $C_L = 100\text{ pF}$, $C_{\text{L(RXD)}} = 15\text{ pF}$ See 6-6		115	215	ns
$t_{\text{PROP(LOOP2)}}$	Total loop delay, driver input (TXD) to receiver output (RXD) Dominant to recessive	$R_L = 60\ \Omega$, $C_L = 100\text{ pF}$, $C_{\text{L(RXD)}} = 15\text{ pF}$ See 6-6		115	205	ns
$t_{\text{WK(TIMEOUT)}}$	Bus wake-up timeout value ⁽¹⁾		0.8		2	ms
$t_{\text{WK(FILTER)}}$	Bus time to meet filtered bus requirements for wake-up request ⁽¹⁾		0.5		1.8	μs
t_{SILENCE}	Timeout for bus inactivity ⁽¹⁾	Timer is reset and restarted, when bus changes from dominant to recessive or vice versa	0.6		1.2	s
t_{BIAS}	Bus bias reaction time ⁽¹⁾	Measured from the start of a dominant-recessive-dominant sequence (each phase 6 μs) until $V_{\text{SYM}} \geq 0.1$ nSTB = EN = 0 V, $R_L = 60\ \Omega$, $C_{\text{SPLIT}} = 4.7\text{ nF}$ See 6-9			200	μs
t_{CBF}	Bus fault-detection time	$45 \leq R_{\text{CM}} \leq 70\ \Omega$ $C_L = \text{open}$	2.5			μs
$t_{\text{WAKE_HT}}$	Hold time for which WAKE pin voltage should be stable after the rising or falling edge on WAKE pin to recognize LWU.		5		50	μs
Mode Change Characteristics						
$t_{\text{INH_SLP_STB}}$	Time after WUP or LWU event until INH asserted ⁽¹⁾				100	μs
t_{MODE1}	Mode change time from leaving the Sleep mode to entering Normal or Silent mode ⁽¹⁾	Time measured from VCC and VIO crossing UV thresholds to entering normal or silent mode.			20	μs
t_{MODE2}	Mode change time between normal, silent and standby mode and from sleep to standby mode ⁽¹⁾	Mode change time between normal, silent and standby mode and from sleep to standby mode			10	μs

5.9 Timing Requirements (続き)

over operating free-air temperature range (unless otherwise noted)

PARAMETER		TEST CONDITIONS	MIN	TYP	MAX	UNIT
$t_{\text{GOTOSLEEP}}$	Minimum hold time for transition to sleep mode ⁽¹⁾	EN = H and nSTB = L	20		50	μs

(1) Specified by design and verified via bench characterization

5.10 Switching Characteristics

Over recommended operating conditions with $T_J = -40^{\circ}\text{C}$ to 150°C , unless otherwise noted. All typical values are taken at 25°C , $V_{\text{SUP}} = 12\text{ V}$, $V_{\text{IO}} = 3.3\text{ V}$, $V_{\text{CC}} = 5\text{ V}$ and $R_L = 60\ \Omega$

PARAMETER		TEST CONDITIONS		MIN	TYP	MAX	UNIT
Driver Characteristics							
$t_{\text{prop(TxD-busrec)}}$	Propagation delay time, high TXD to driver recessive	Propagation delay time, high TXD to driver recessive	$R_L = 60\ \Omega$, $C_L = 100\ \text{pF}$, $R_{\text{CM}} = \text{open}$ See 6-4	25	50	90	ns
$t_{\text{prop(TxD-busdom)}}$	Propagation delay time, low TXD to driver dominant			25	50	90	ns
$t_{\text{sk(p)}}$	Pulse skew ($t_{\text{pHR}} - t_{\text{pLDI}}$)			4			ns
t_{R}	Differential output signal rise time			40			ns
t_{F}	Differential output signal fall time			40			ns
t_{TXDDTO}	Dominant timeout		$\text{TXD} = 0\ \text{V}$, $R_L = 60\ \Omega$, $C_L = \text{open}$ See 6-7	1.2		3.8	ms
Receiver Characteristics							
$t_{\text{prop(busrec-RxD)}}$	Propagation delay time, bus recessive input to high RXD	$C_{\text{L(RXD)}} = 15\ \text{pF}$ See 6-5	$R_L = 60\ \Omega$, $C_L = \text{open}$ See 6-5	25	75	140	ns
$t_{\text{prop(busdom-RxD)}}$	Propagation delay time, bus dominant input to RXD low output			20	75	130	ns
t_{R}	Output signal rise time (RXD)			4			ns
t_{F}	Output signal fall time (RXD)			4			ns
t_{BUSDOM}	Dominant time out			1.4		3.8	ms
CAN FD Characteristics							
$t_{\Delta\text{BIT(BUS)}}^{(1)}$	Transmitted recessive bit width variation on CAN bus output pins with $t_{\text{BIT(TXD)}} = 500\ \text{ns}$	Transmitted recessive bit width variation on CAN bus output pins with $t_{\text{BIT(TXD)}} = 500\ \text{ns}$		$R_L = 60\ \Omega$, $C_{\text{L1}} = \text{open}$, $C_{\text{L2}} = 100\ \text{pF}$, $C_{\text{L(RXD)}} = 15\ \text{pF}$ $t_{\Delta\text{BIT(BUS)}} = t_{\text{BIT(BUS)}} - t_{\text{BIT(TXD)}}$ See 6-6	-50	25	ns
$t_{\Delta\text{BIT(BUS)}}^{(1)}$	Transmitted recessive bit width variation on CAN bus output pins with $t_{\text{BIT(TXD)}} = 200\ \text{ns}$	Transmitted recessive bit width variation on CAN bus output pins with $t_{\text{BIT(TXD)}} = 200\ \text{ns}$		$R_L = 60\ \Omega$, $C_{\text{L1}} = \text{open}$, $C_{\text{L2}} = 100\ \text{pF}$, $C_{\text{L(RXD)}} = 15\ \text{pF}$ $t_{\Delta\text{BIT(BUS)}} = t_{\text{BIT(BUS)}} - t_{\text{BIT(TXD)}}$ See 6-6	-40	10	ns
$t_{\Delta\text{BIT(BUS)}}^{(1)}$	Transmitted recessive bit width variation on CAN bus output pins with $t_{\text{BIT(TXD)}} = 125\ \text{ns}$	Transmitted recessive bit width variation on CAN bus output pins with $t_{\text{BIT(TXD)}} = 125\ \text{ns}$		$R_L = 60\ \Omega$, $C_{\text{L1}} = \text{open}$, $C_{\text{L2}} = 100\ \text{pF}$, $C_{\text{L(RXD)}} = 15\ \text{pF}$ $t_{\Delta\text{BIT(BUS)}} = t_{\text{BIT(BUS)}} - t_{\text{BIT(TXD)}}$ See 6-6	-45	10	ns
$t_{\Delta\text{BIT(RXD)}}^{(1)}$	Received recessive bit width variation on RXD output pins with $t_{\text{BIT(TXD)}} = 500\ \text{ns}$	Received recessive bit width variation on RXD output pins with $t_{\text{BIT(TXD)}} = 500\ \text{ns}$		$R_L = 60\ \Omega$, $C_{\text{L1}} = \text{open}$, $C_{\text{L2}} = 100\ \text{pF}$, $C_{\text{L(RXD)}} = 15\ \text{pF}$ $t_{\Delta\text{BIT(RXD)}} = t_{\text{BIT(RXD)}} - t_{\text{BIT(TXD)}}$ See 6-6	-90	40	ns
$t_{\Delta\text{BIT(RXD)}}^{(1)}$	Received recessive bit width variation on RXD output pins with $t_{\text{BIT(TXD)}} = 200\ \text{ns}$	Received recessive bit width variation on RXD output pins with $t_{\text{BIT(TXD)}} = 200\ \text{ns}$		$R_L = 60\ \Omega$, $C_{\text{L1}} = \text{open}$, $C_{\text{L2}} = 100\ \text{pF}$, $C_{\text{L(RXD)}} = 15\ \text{pF}$ $t_{\Delta\text{BIT(RXD)}} = t_{\text{BIT(RXD)}} - t_{\text{BIT(TXD)}}$ See 6-6	-70	20	ns
$t_{\Delta\text{BIT(RXD)}}^{(1)}$	Received recessive bit width variation on RXD output pins with $t_{\text{BIT(TXD)}} = 125\ \text{ns}$	Received recessive bit width variation on RXD output pins with $t_{\text{BIT(TXD)}} = 125\ \text{ns}$		$R_L = 60\ \Omega$, $C_{\text{L1}} = \text{open}$, $C_{\text{L2}} = 100\ \text{pF}$, $C_{\text{L(RXD)}} = 15\ \text{pF}$ $t_{\Delta\text{BIT(RXD)}} = t_{\text{BIT(RXD)}} - t_{\text{BIT(TXD)}}$ See 6-6	-65	20	ns

5.10 Switching Characteristics (続き)

Over recommended operating conditions with $T_J = -40^\circ\text{C}$ to 150°C , unless otherwise noted. All typical values are taken at 25°C , $V_{\text{SUP}} = 12\text{ V}$, $V_{\text{IO}} = 3.3\text{ V}$, $V_{\text{CC}} = 5\text{ V}$ and $R_L = 60\ \Omega$

PARAMETER		TEST CONDITIONS	MIN	TYP	MAX	UNIT
$t_{\Delta\text{REC}}^{(1)}$	Receiver timing symmetry with $t_{\text{BIT(TXD)}} = 500\text{ ns}$	$R_L = 60\ \Omega$, $C_{L1} = \text{open}$, $C_{L2} = 100\text{ pF}$, $C_{L(\text{RXD})} = 15\text{ pF}$ $\Delta t_{\text{REC}} = t_{\text{BIT(RXD)}} - t_{\text{BIT(BUS)}}$ See 6-6	-50		20	ns
	Receiver timing symmetry with $t_{\text{BIT(TXD)}} = 200\text{ ns}$	$R_L = 60\ \Omega$, $C_{L1} = \text{open}$, $C_{L2} = 100\text{ pF}$, $C_{L(\text{RXD})} = 15\text{ pF}$ $\Delta t_{\text{REC}} = t_{\text{BIT(RXD)}} - t_{\text{BIT(BUS)}}$ See 6-6	-45		15	ns
	Receiver timing symmetry with $t_{\text{BIT(TXD)}} = 125\text{ ns}^{(2)}$	$R_L = 60\ \Omega$, $C_{L1} = \text{open}$, $C_{L2} = 100\text{ pF}$, $C_{L(\text{RXD})} = 15\text{ pF}$ $\Delta t_{\text{REC}} = t_{\text{BIT(RXD)}} - t_{\text{BIT(BUS)}}$ See 6-6	-25		10	ns

- (1) The input signal on TXD shall have rise times and fall times (10% to 90%) of less than 10 ns
(2) Specified by design and verified via bench characterization

5.11 Typical Characteristics



図 5-1. $V_{OD(DOM)}$ vs V_{CC} and Temperature



図 5-2. I_{CC} Recessive vs V_{CC} and Temperature

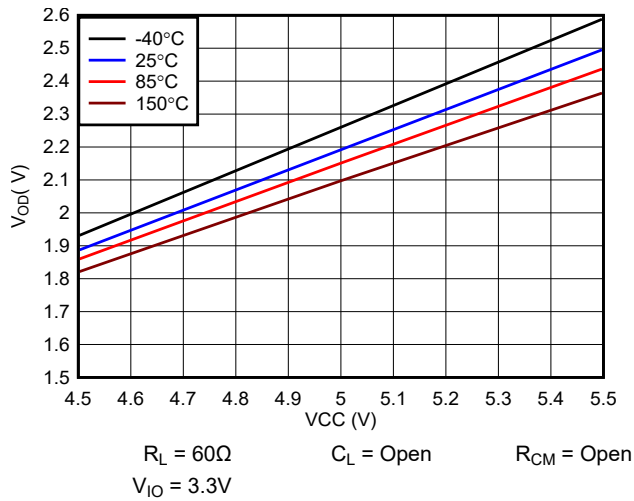

図 5-3. I_{SUP} in Sleep Mode vs V_{SUP} and Temperature

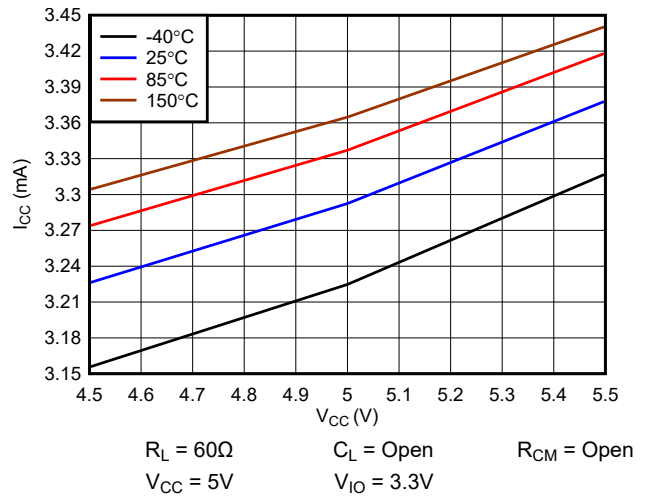

図 5-4. Loop Propagation Delay vs V_{IO} and Temperature

6 Parameter Measurement Information

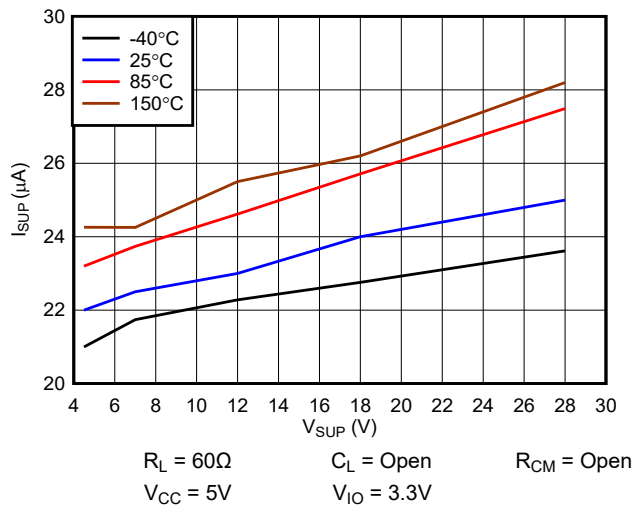

図 6-1. Common-Mode Bias Unit and Receiver

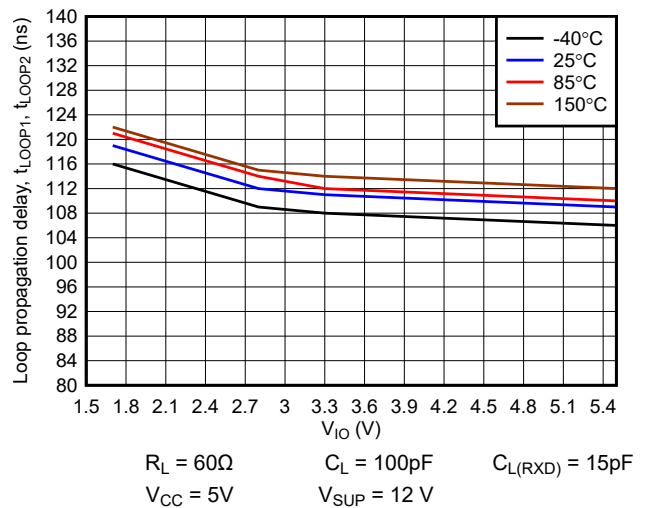

図 6-2. Test Circuit

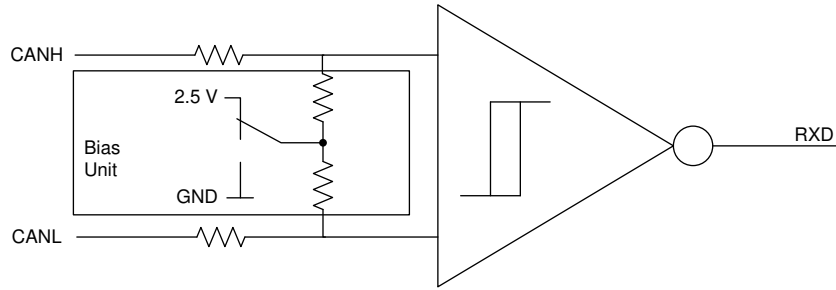

図 6-3. Supply Test Circuit

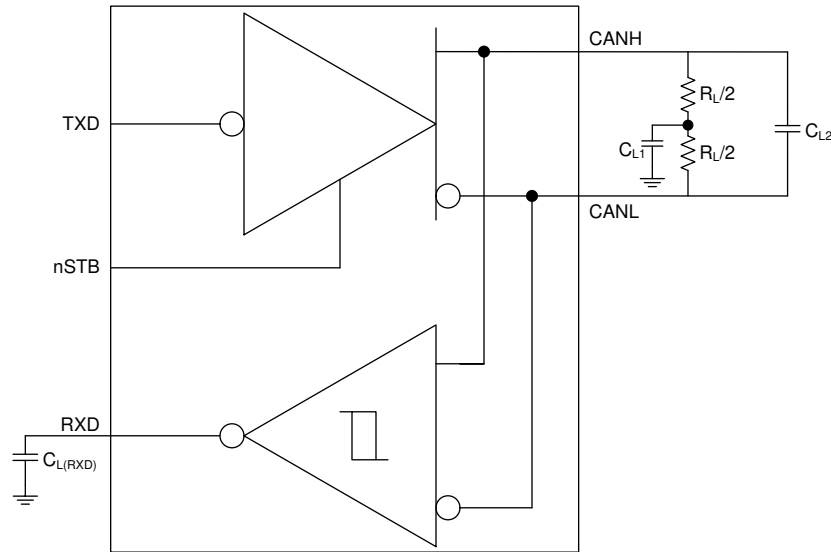

图 6-4. Driver Test Circuit and Measurement

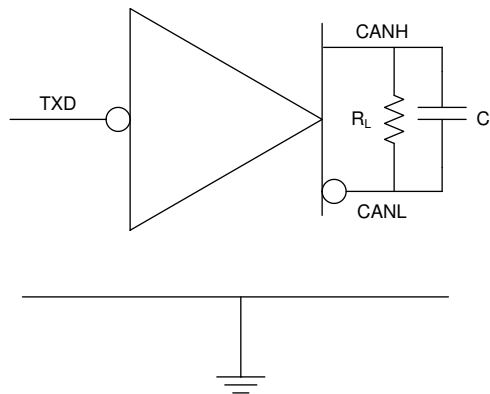

图 6-5. Receiver Test Circuit and Measurement

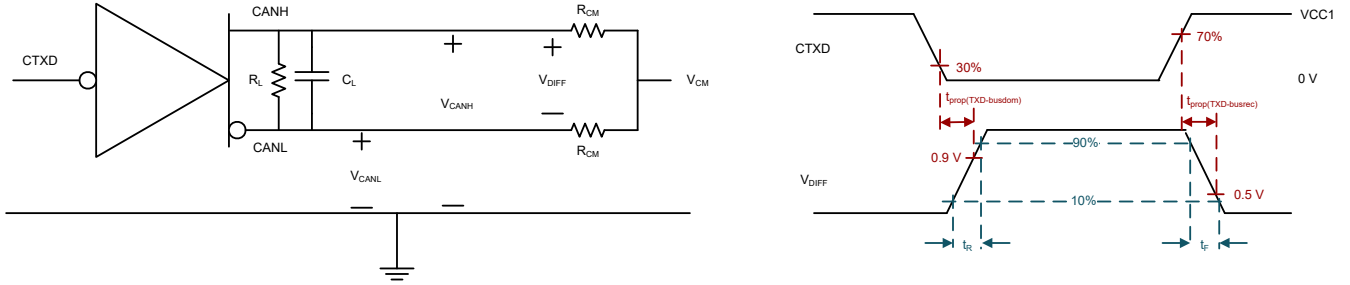

图 6-6. Transmitter and Receiver Timing Behavior Test Circuit and Measurement

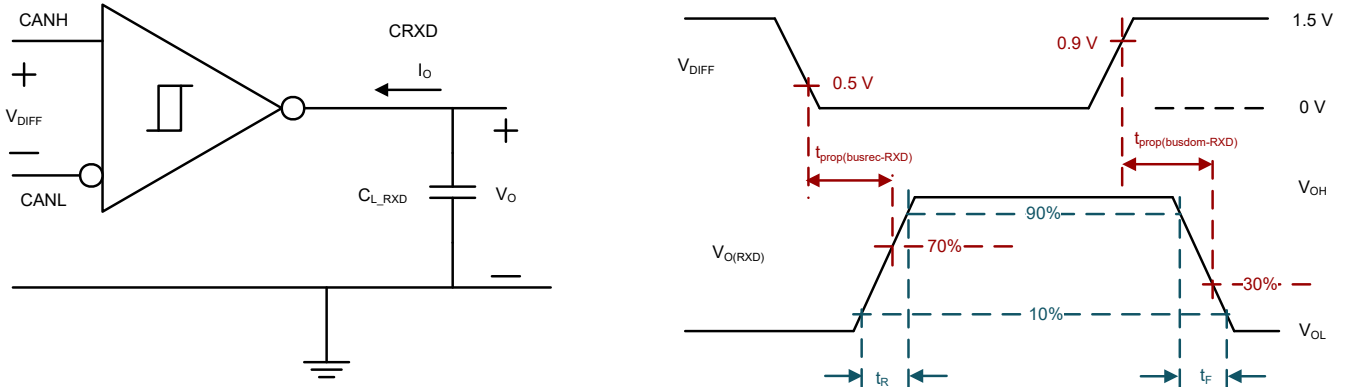

图 6-7. TXD Dominant Time Out Test Circuit and Measurement

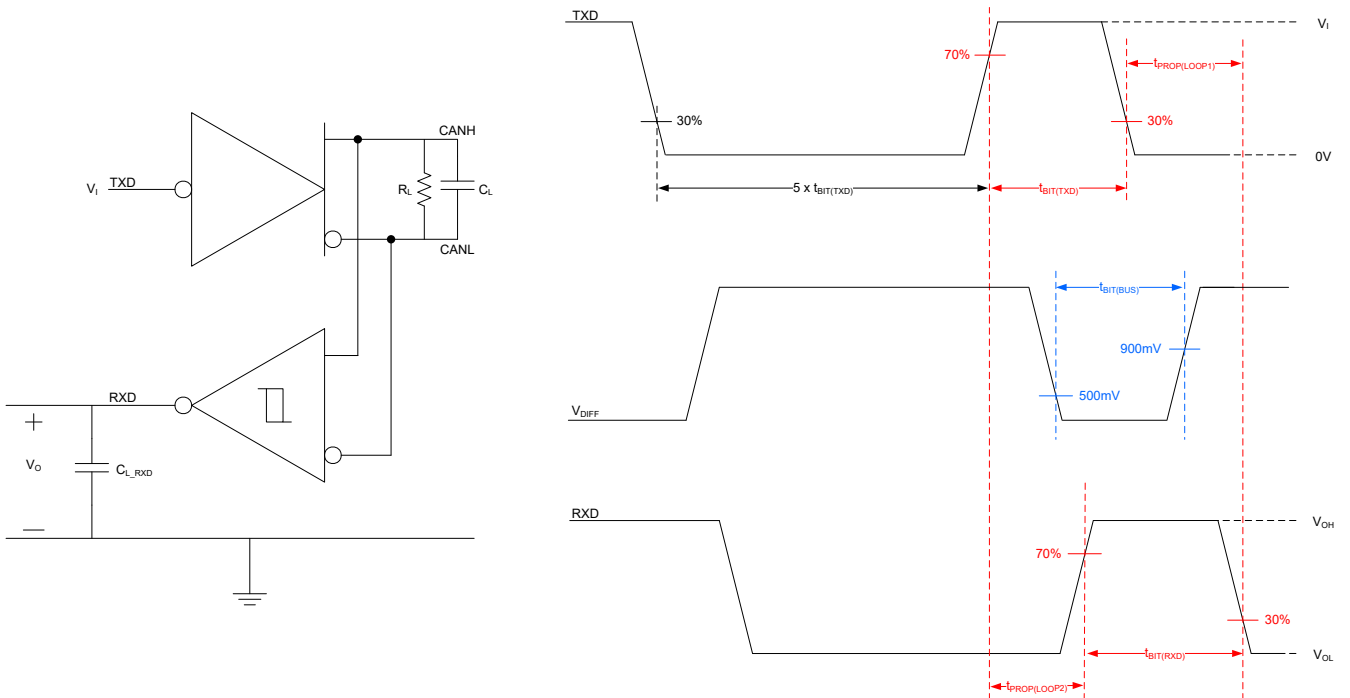

图 6-8. Driver Short-Circuit Current Test and Measurement

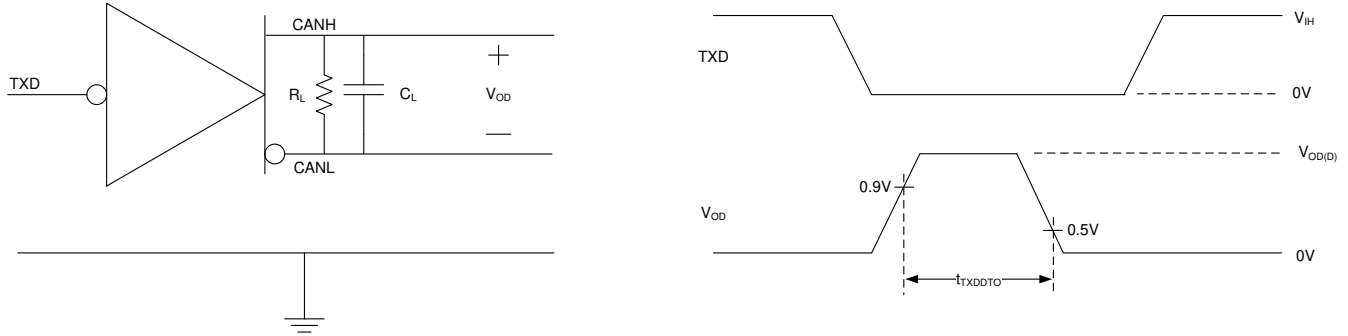

图 6-9. Bias Reaction Time Measurement

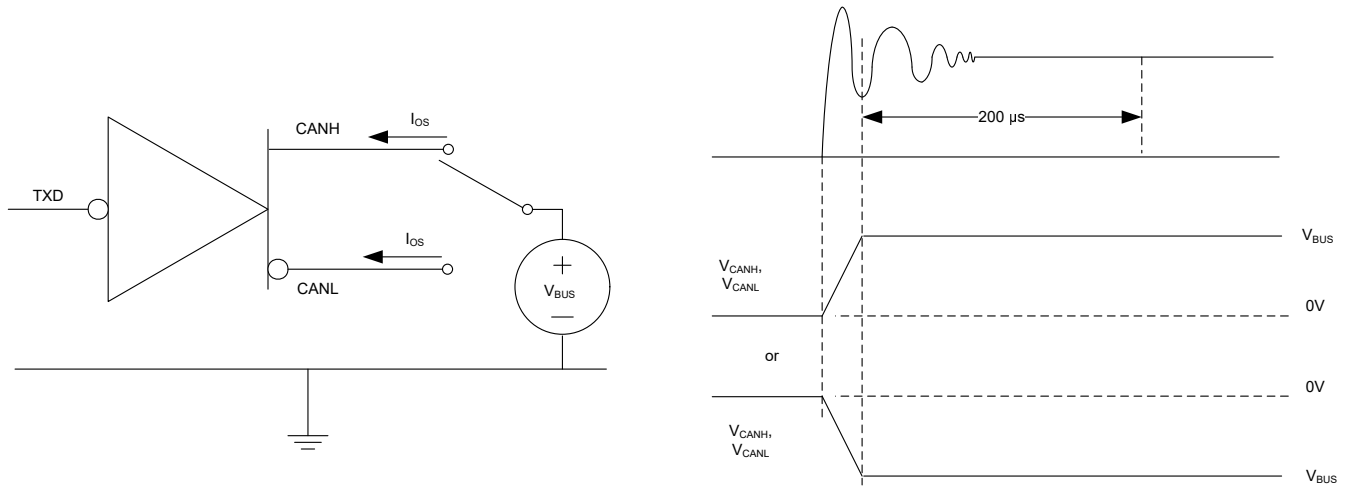

 **6-10. Power-Up Timing**

7 Detailed Description

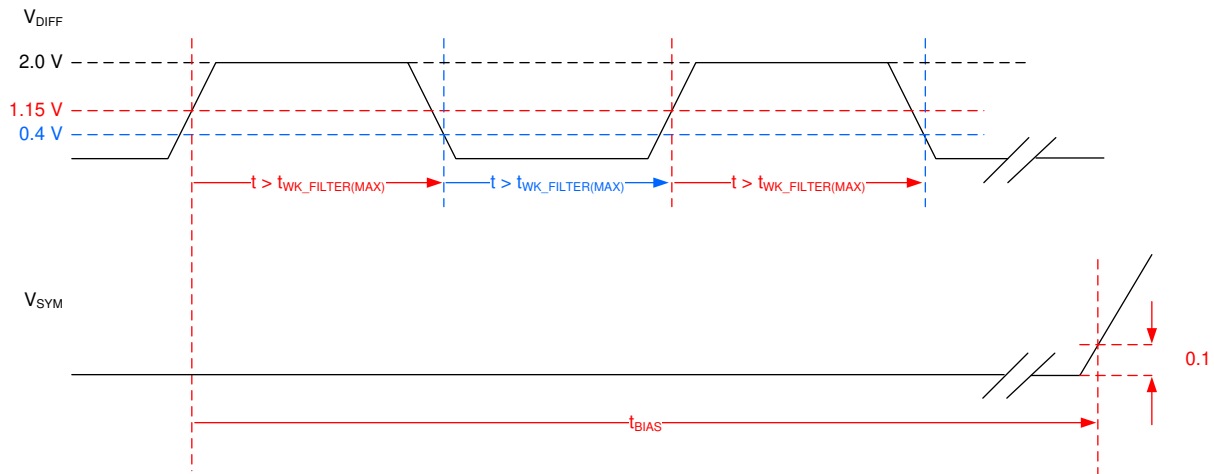
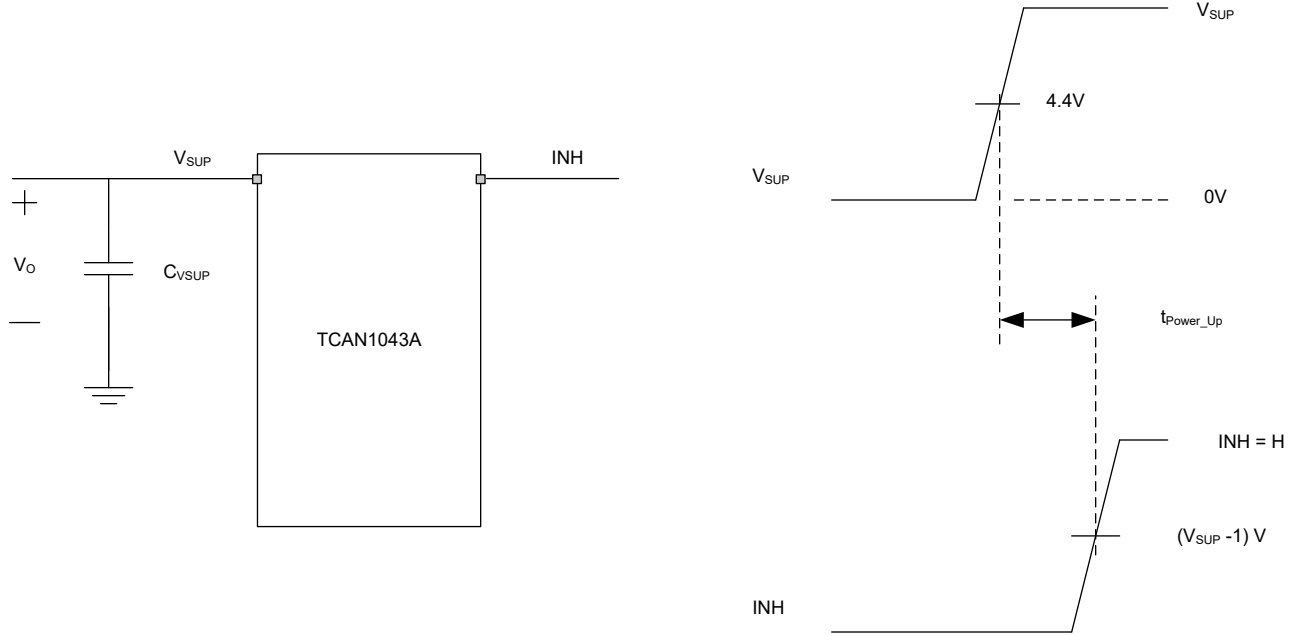
7.1 Overview

The transceiver has three separate supply inputs, V_{SUP} , V_{CC} , and V_{IO} . By using V_{IO} , the TCAN1043N-Q1 can interface directly to a 1.8V, 2.5V, 3.3V, or 5V controller without the need for a level shifter. The TCAN1043N-Q1 allows for system-level reductions in battery current consumption by selectively enabling the various power supplies that may be present in the system via the INH output pin. This enables a low-current sleep state in which power is gated to all system components except for the TCAN1043N-Q1, which remains in a low-power state while monitoring the CAN bus. When a wake-up pattern is detected on the bus or when a local wake up is requested via the WAKE input, the device initiates node start-up by driving INH high.

The TCAN1043N-Q1 includes many protection and diagnostic features including undervoltage detection, CAN bus fault detection, battery connection detection, thermal shutdown (TSD), driver dominant timeout (TXD DTO), and bus fault protection up to $\pm 58V$.

7.2 Functional Block Diagram



図 7-1. TCAN1043N-Q1 Functional Block Diagram

7.3 Feature Description

7.3.1 Supply Pins

The TCAN1043N-Q1 implements three independent supply inputs for regulating different portions of the device.

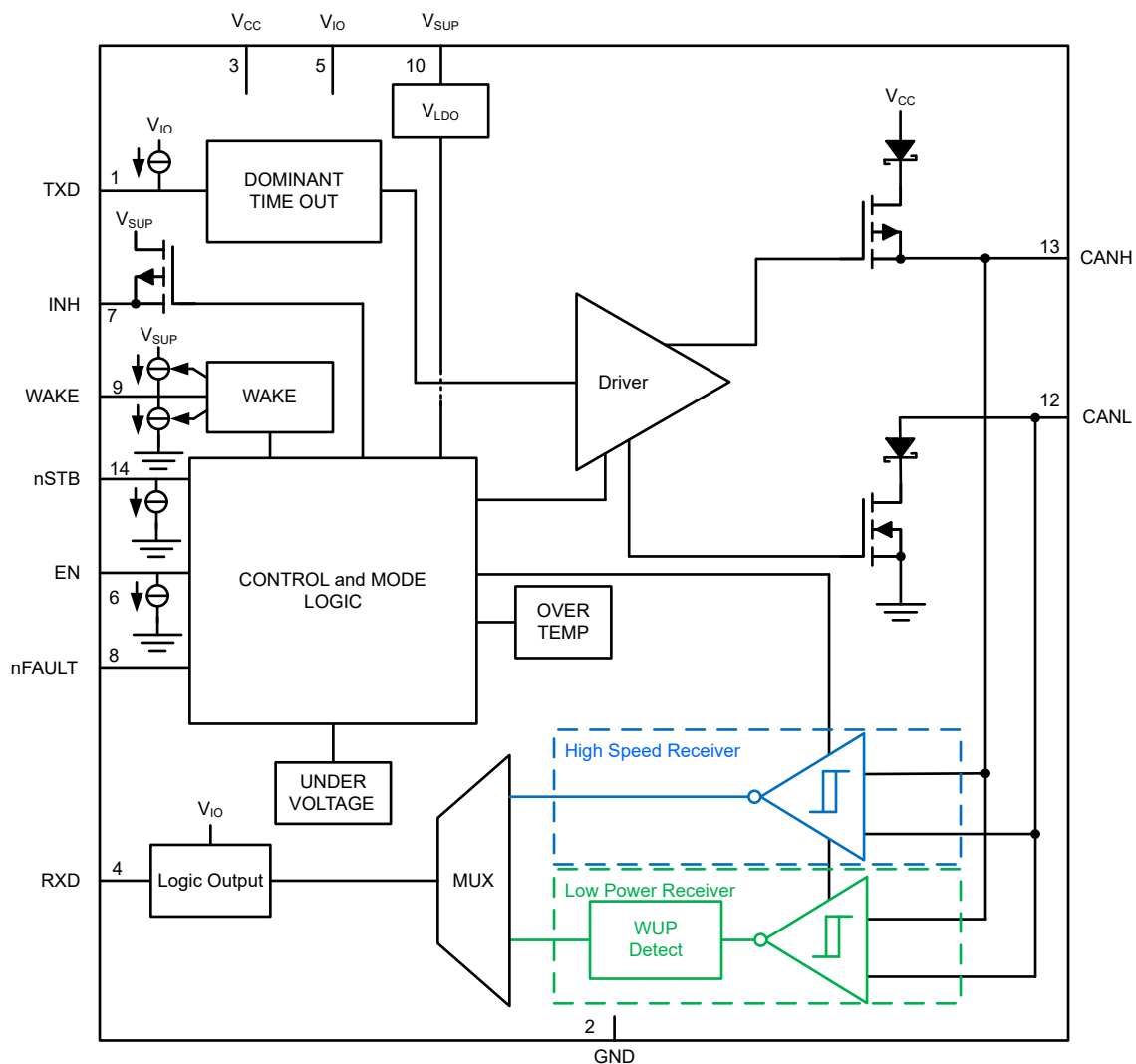
7.3.1.1 V_{SUP} Pin

This pin is connected to the battery supply. The pin provides the supply to the internal regulators that support the digital core and the low power CAN receiver.

7.3.1.2 V_{CC} Pin

This pin provides the 5V supply voltage for the CAN transceiver.

7.3.1.3 V_{IO} Pin

This pin provides the digital I/O voltage to match the CAN FD controller I/O voltage. It supports I/O voltages from 1.7V to 5.5V providing a wide range of controller support.

7.3.2 Digital Inputs and Outputs

7.3.2.1 TXD Pin

TXD is a logic-level input signal, referenced to V_{IO} , from a CAN FD controller to the TCAN1043N-Q1. TXD is biased to the V_{IO} level to force a recessive input in case the pin floats.

7.3.2.2 RXD Pin

RXD is a logic-level signal output, referenced to V_{IO} , from the TCAN1043N-Q1 to a CAN FD controller. The RXD pin is driven to the V_{IO} level as logic-high outputs once a valid V_{IO} is present.

When a power-on or wake-up event takes place, the RXD pin is pulled low.

7.3.2.3 nFAULT Pin

nFAULT is a logic-level output signal, referenced to V_{IO} , from the TCAN1043N-Q1 to a CAN FD controller. The nFAULT output is driven to the V_{IO} level as logic-high output.

The nFAULT output is used to transmit the TCAN1043N-Q1 status indicator flags to the CAN FD controller. Please see [表 7-1](#) for the specific fault scenarios that are indicated externally via the nFAULT pin.

7.3.2.4 EN Pin

EN is a logic-level input signal, referenced to V_{IO} , from a CAN FD controller to the TCAN1043N-Q1. The EN input pin is for mode selection in conjunction with the nSTB pin. EN is internally pulled low to prevent excessive system power and false wake-up events.

7.3.2.5 nSTB Pin

nSTB is a logic-level input signal, referenced to V_{IO} , from a CAN FD controller to the TCAN1043N-Q1. The nSTB input pin is for mode selection in conjunction with the EN pin. nSTB is internally pulled low to prevent excessive system power and false wake-up events.

7.3.3 GND

GND is the ground pin of the transceiver, it must be connected to the PCB ground.

7.3.4 INH Pin

The INH pin is a high-voltage output. It can be used to control external regulators. These regulators are usually used to support the microprocessor and V_{IO} pin. The INH function is on in all modes except for sleep mode. In sleep mode, the INH pin is turned off, going into a high-impedance state. This allows the node to be placed into the lowest power state while in sleep mode. A 100k Ω load can be added to the INH output for a fast transition time from the driven high state to the low state and to force the pin low when left floating.

This terminal should be considered a high-voltage logic terminal, not a power output. The INH pin should be used to drive the EN terminal of the system power management device, and is not used as a switch for the

power management supply itself. This terminal is not reverse-battery protected, and must not be connected outside the system module.

7.3.5 WAKE Pin

The WAKE pin is a high-voltage reverse-blocked input used for the local wake-up (LWU) function. The WAKE pin is bi-directional edge-triggered and recognizes a local wake-up (LWU) on either a rising or falling edge of WAKE pin transition. The LWU function is explained further in the [Local Wake-Up \(LWU\) via WAKE Input Terminal](#) section.

7.3.6 CAN Bus Pins

These are the CAN high and CAN low, CANH and CANL, differential bus pins. These pins are internally connected to the CAN transceiver and the low-voltage wake receiver.

7.3.7 Faults

7.3.7.1 Internal and External Fault Indicators

The following device status indicator flags are implemented to allow for the MCU to determine the status of the device and the system. In addition to faults, the nFAULT terminal also signals wake-up requests and a *cold* power-up sequence on the V_{SUP} battery terminal so the system can do any diagnostics or cold booting sequence necessary. The RXD terminal indicates wake-up request and the faults are multiplexed (ORed) to the nFAULT output.

表 7-1. TCAN1043N-Q1 Transceiver Status Indicator

EVENT	FLAG NAME	CAUSE	INDICATORS ⁽¹⁾	FLAG IS CLEARED	COMMENT
Power-up	<i>PWRON</i>	Power up on V_{SUP} and any return of V_{SUP} after it has been below UV_{SUP}	nFAULT = low upon entering silent mode from standby or sleep mode	After a transition to normal mode	A cold start condition generates a local wake-up WAKERQ, WAKESR and a PWRON flag.
Wake-up Request	<i>WAKERQ</i> ⁽²⁾		nFAULT = RXD = low after wake-up upon entering standby mode	After a transition to normal mode or $V_{CC} < UV_{CC(F)}$ or $V_{IO} < UV_{IO(F)}$ for $t \geq t_{UV}$	Wake-up request may only be set from standby, go-to-sleep, or sleep mode. Resets timers for UV_{VCC} or UV_{VIO} .
Wake-up Source Recognition ⁽³⁾	<i>WAKESR</i>	Wake-up event on CAN bus, state transition on WAKE pin, or initial power up	Available upon entering normal mode ⁽⁴⁾ nFAULT = low indicates a local wake-up event from the WAKE pin nFAULT = high indicates a remote wake-up event from the CAN bus	After four recessive-to-dominant edges on TXD in normal mode, leaving normal mode, or $V_{CC} < UV_{CC(F)}$ or $V_{IO} < UV_{IO(F)}$ for $t \geq t_{UV}$	A cold start condition generates a local wake-up WAKERQ, WAKESR and a PWRON flag.
Undervoltage	UV_{CC}	$V_{CC} < UV_{CC(F)}$	Not externally indicated	$V_{CC} > UV_{CC(R)}$, or a wake-up request occurs	
	UV_{IO}	$V_{IO} < UV_{IO(F)}$	Not externally indicated	$V_{IO} > UV_{IO(R)}$, or a wake-up request occurs	
	UV_{SUP}	$V_{SUP} < UV_{SUP(F)}$	Not externally indicated	$V_{SUP} > UV_{SUP(R)}$	A V_{SUP} undervoltage event generates a cold start condition once $V_{SUP} > UV_{SUP(R)}$
CAN Bus Fault	<i>CBF</i>	See CAN Bus Fault	nFAULT = low in normal mode only ⁽⁵⁾	Upon leaving normal mode, or if no CAN bus fault is detected for four consecutive dominant-to-recessive transitions of the TXD pin while in normal mode	CAN bus fault must persist for four consecutive dominant-to-recessive transitions
Local Faults	<i>TXDDTO</i>	TXD dominant time out, dominant (low) signal for $t \geq t_{TXDDTO}$	nFAULT = low upon entering silent mode from normal mode	RXD = low & TXD = high, TXD = high & a mode transition into normal, standby, go-to-sleep, or sleep modes	CAN driver remains disabled until the <i>TXDDTO</i> is cleared. CAN receiver remains active during the <i>TXDDTO</i> fault
	<i>TXDRXD</i>	TXD and RXD pins are shorted together for $t \geq t_{TXDDTO}$			CAN driver remains disabled until the <i>TXDRXD</i> is cleared. CAN receiver remains active during the <i>TXDRXD</i> fault
	<i>CANDOM</i>	CAN bus dominant fault, when dominant bus signal received for $t \geq t_{BUSDOM}$		RXD = high, or a transition into normal, standby, go-to-sleep, or sleep modes	CAN driver remains enabled during <i>CANDOM</i> fault
	<i>TSD</i>	Thermal shutdown, $T_J \geq T_{SDR}$		$T_J < T_{SDF}$ and RXD = low & TXD = high, or transition into normal, standby, go-to-sleep, or sleep modes	CAN driver remains disabled until the <i>TSD</i> event is cleared

- (1) V_{IO} and V_{SUP} are present
- (2) Transitions to go-to-sleep mode is blocked until WAKERQ flag is cleared
- (3) Wake-up source recognition reflects the first wake up source. If additional wake-up events occur the source still indicates the original wake-up source
- (4) Indicator is only available in normal mode until the flag is cleared
- (5) CAN Bus failure flag is indicated after four dominant-to-recessive edges on TXD

7.3.7.1.1 Power-Up (*PWRON* Flag)

This is an internal and external flag that can be used to control the power-up sequence of the system. When a new battery connection to the transceiver is made the *PWRON* flag is set signifying a cold start condition. The TCAN1043N-Q1 treats any undervoltage conditions on the V_{SUP} , $V_{SUP} < UV_{SUP(F)}$, as a cold start. Therefore, when the $V_{SUP} > UV_{SUP(R)}$ condition is met the TCAN1043N-Q1 sets the *PWRON* flag which can be used by the system to enter a routine that is only called upon in cold start situations. The *PWRON* flag is indicated by nFAULT driven low after entering silent mode from either standby mode or sleep mode. This flag is cleared after a transition to normal mode.



図 7-2. Distinguishing between *PWRON* and Wake Request by Entering Silent Mode

7.3.7.1.2 Wake-Up Request (WAKERQ Flag)

This is an internal and external flag that can be set in standby, go-to-sleep, or sleep mode. This flag is set when either a valid local wake-up (LWU) request occurs, or a valid remote wake request occurs, or on power up on V_{SUP} . The setting of this flag clears the t_{UV} timer for the UV_{CC} or UV_{IO} fault detection. This flag is cleared upon entering normal mode or during an undervoltage event on V_{CC} or V_{IO} .

7.3.7.1.3 Undervoltage Faults

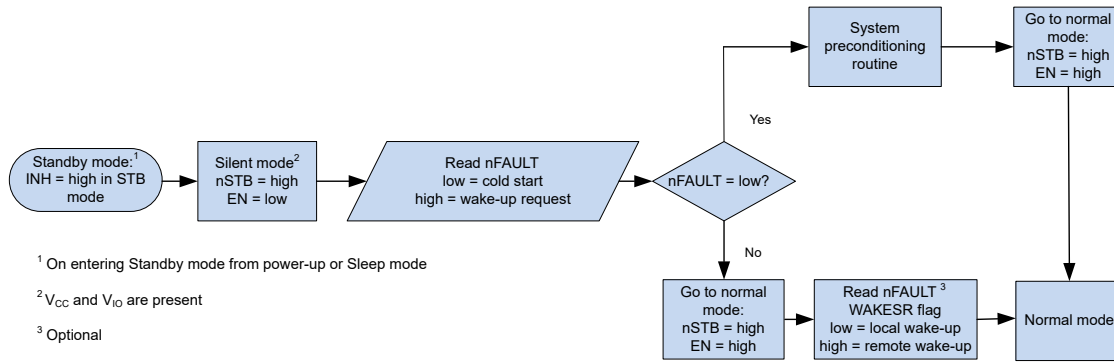
The TCAN1043N-Q1 device implements undervoltage detection circuits on all supply terminals: V_{SUP} , V_{CC} , and V_{IO} . The undervoltage flags are internal indicator flags and are not indicated on the nFAULT output pin.

7.3.7.1.3.1 Undervoltage on V_{SUP}

UV_{SUP} is set when the voltage on V_{SUP} drops below the undervoltage detection voltage threshold, UV_{SUP} . The PWRON and WAKERQ flags are set once $V_{SUP} > UV_{SUP(R)}$.

7.3.7.1.3.2 Undervoltage on V_{CC}

UV_{CC} is set when the voltage on V_{CC} drops below the undervoltage detection voltage threshold, UV_{CC} , for longer than the t_{UV} undervoltage filter time.

7.3.7.1.3.3 Undervoltage on V_{IO}

UV_{IO} is set when the voltage on V_{IO} drops below the undervoltage detection voltage threshold, UV_{IO} , for longer than the t_{UV} undervoltage filter time.

7.3.7.1.4 CAN Bus Fault (CBF Flag)

The TCAN1043N-Q1 device can detect the following six fault conditions and set the nFAULT pin low as an interrupt so that the controller can be notified and act if a CAN bus fault exists. These failures are detected while transmitting a dominant signal on the CAN bus. If one of these fault conditions persists for four consecutive dominant-to-recessive bit transitions, the nFAULT indicates a CAN bus failure flag in Normal mode by driving the nFAULT pin low. The CAN bus driver remains active. 表 7-2 shows what fault conditions can be detected by the TCAN1043N-Q1.

表 7-2. Bus Fault Pin State and Detection Table

FAULT	Condition
1	CANH Shorted to V_{BAT}
2	CANH Shorted to V_{CC}
3	CANH Shorted to GND
4	CANL Shorted to V_{BAT}
5	CANL Shorted to V_{CC}
6	CANL Shorted to GND

Bus fault detection is a system level situation. If the fault is occurring at the ECU, the general communication of the bus may be compromised. Until a diagnostic determination can be made, the transceiver remains in CAN active mode during a CAN bus fault enabling the ECU to transmit data to the CAN bus and receive data from the CAN bus. For complete coverage of a node, a system level diagnostic step should be performed for each node and the information should be communicated back to a central point.

While in normal mode, if no CAN bus fault is detected for four consecutive dominant-to-recessive transitions on the TXD pin then the CBF flag is cleared and nFAULT is driven high. The bus fault failure circuitry is able to detect bus faults for a range of differential resistance loads (R_{CBF}) and for any time greater than t_{CBF} .

7.3.7.1.5 TXD Dominant State Timeout (TXDDTO Flag)

TXDDTO is an external flag that is set if the TXD pin is held dominant for $t > t_{TXDDTO}$. If a TXD DTO condition exists, the nFAULT pin is driven low upon entering silent mode from normal mode. The *TXDDTO* flag is cleared on the next dominant-to-recessive transition on TXD or upon a transition into normal, standby, go-to-sleep, or sleep modes.

7.3.7.1.6 TXD Shorted to RXD Fault (TXDRXD Flag)

TXDRXD is an external flag that is set if the transceiver detects that the TXD and RXD lines have been shorted together for $t \geq t_{TXDDTO}$. If a *TXDRXD* condition exists the nFAULT pin is driven low upon entering silent mode from normal mode and the CAN bus driver is disabled until the *TXDRXD* fault is cleared. The *TXDRXD* flag is cleared on the next dominant-to-recessive transition with TXD high and RXD low or upon a transition into normal, standby, go-to-sleep, or sleep modes.

7.3.7.1.7 CAN Bus Dominant Fault (CANDOM Flag)

CANDOM is an external flag that is set if the CAN bus is stuck dominant state for $t > t_{BUSDOM}$. If a *CANDOM* condition exists the nFAULT pin is driven low upon entering silent mode from normal mode. The *CANDOM* flag is cleared on the next dominant-to-recessive transition on RXD or upon a transition into normal, standby, go-to-sleep, or sleep modes.

7.3.8 Local Faults

Local faults are detected in both normal mode and silent mode, but are only indicated via the nFAULT pin when the TCAN1043N-Q1 transitions from normal mode to silent mode. All other mode transitions clear the local fault flag indicators.

7.3.8.1 TXD Dominant Timeout (TXD DTO)

While the CAN driver is in active mode a TXD dominant state timeout circuit prevents the local node from blocking network communication in event of a hardware or software failure where TXD is held dominant longer than the timeout period, $t > t_{TXDDTO}$. The TXD dominant state timeout circuit is triggered by a falling edge on the TXD pin. If no rising edge is seen before on TXD before $t > t_{TXDDTO}$ then the CAN driver is disabled releasing the bus lines to the recessive level. This keeps the bus free for communication between other nodes on the network.

The CAN driver will be activated again on the next dominant-to-recessive transition on the TXD pin. During a *TXDDTO* fault the high-speed receiver remains active and the RXD output pin will mirror the CAN bus.



図 7-3. Timing Diagram for TXD DTO

The minimum dominant TXD time allowed by the dominant state timeout circuit limits the minimum possible transmitted data rate of the transceiver. The CAN protocol allows a maximum of eleven successive dominant bits to be transmitted in the worst case, where five successive dominant bits are followed immediately by an error frame. The minimum transmitted data rate may be calculated using the minimum t_{TXDDTO} time in 式 1.

$$\text{Minimum Data Rate} = 11 \text{ bits} / t_{TXDDTO} = 11 \text{ bits} / 1.2\text{ms} = 9.2\text{kbps} \quad (1)$$

7.3.8.2 Thermal Shutdown (TSD)

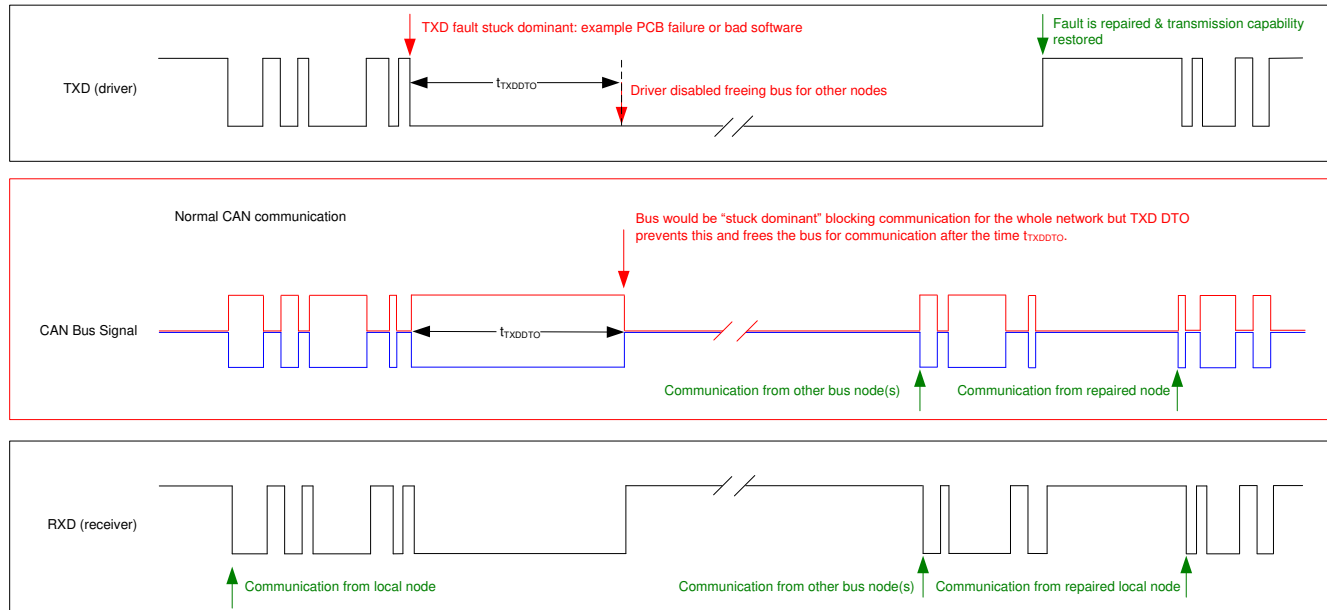
If the junction temperature of the TCAN1043N-Q1 exceeds the thermal shutdown threshold the device turns off the CAN driver circuits thus blocking the TXD to bus transmission path. The CAN bus terminals are biased to recessive level during a TSD fault and the receiver to RXD path remains operational. The TSD fault condition is cleared when the junction temperature, T_J , of the device drops below the thermal shutdown release temperature, T_{SDF} , of the device. If the fault condition that caused the TSD fault is still present, the temperature may rise again and the device will enter thermal shutdown again. Prolonged operation with TSD fault conditions may affect device reliability. The TSD circuit includes hysteresis to avoid any oscillation of the driver output. During the fault the TSD fault condition is indicated to the CAN FD controller via the nFAULT terminal.

7.3.8.3 Undervoltage Lockout (UVLO)

The supply terminals, V_{SUP} , V_{IO} and V_{CC} , are monitored for undervoltage events. If an undervoltage event occurs the TCAN1043N-Q1 enters a protected state where the bus pins present no load to the CAN bus. This protects the CAN bus and system from unwanted glitches and excessive current draw that could impact communication between other CAN nodes on the CAN bus.

If an undervoltage event occurs on V_{SUP} in any mode, the TCAN1043N-Q1 CAN transceiver enters the CAN off state.

If an undervoltage event occurs on V_{CC} , the TCAN1043N-Q1 remains in normal or silent mode but the CAN transceiver changes to the CAN autonomous active state. During a UV_{CC} event, RXD remains high as long as V_{IO} is present and the wake-up circuitry is inactive. See 図 7-9. If the undervoltage event persists longer than t_{UV} , the TCAN1043N-Q1 transitions to sleep mode.

If an undervoltage event occurs on the V_{IO} , the TCAN1043N-Q1 transitions to standby mode. If the undervoltage event persists longer than t_{UV} , the TCAN1043N-Q1 transitions to sleep mode.

Once an undervoltage condition is cleared and the supplies have returned to valid levels, the device typically needs 200µs to transition to normal operation.

7.3.8.4 Unpowered Devices

The device is designed to be a passive or no load to the CAN bus if the device is unpowered. The CANH and CANL pins have low leakage currents when the device is unpowered, thus, presenting no load to the bus. This is critical if some nodes of the network are unpowered while the rest of the of network remains in operation.

The logic terminals also have low leakage currents when the device is unpowered, so the terminals do not load down other circuits which may remain powered.

7.3.8.5 Floating Terminals

The TCAN1043N-Q1 has internal pull-ups and pull-downs on critical pins to make sure a known operating behavior if the pins are left floating. See [表 7-3](#) for the pin fail-safe biasing protection description.

表 7-3. Pin Fail-safe Biasing

PIN	FAIL-SAFE PROTECTION	VALUE	COMMENT
TXD	Recessive level	60kΩ	Weak pull-up to V _{IO}
EN	Low-power mode		Weak pull-down to GND
nSTB	Low-power mode		Weak pull-down to GND

This internal bias should not be relied upon by design but rather a fail-safe option. Special care needs to be taken when the transceiver is used with a CAN FD controller that has open-drain outputs. The TCAN1043N-Q1 implements a weak internal pull-up resistor on the TXD pin. The bit timing requirements for CAN FD data rates require special consideration and the pull-up strength should be considered carefully when using open-drain outputs. An adequate external pull-up resistor must be used to make sure the TXD output of the CAN FD controller maintains proper bit timing input to the CAN device.

7.3.8.6 CAN Bus Short-Circuit Current Limiting

The TCAN1043N-Q1 has several protection features that limit the short-circuit current when a CAN bus line is shorted. The features include CAN driver current limiting in the dominant and recessive states, and TXD dominant state timeout which prevents permanently having the higher short-circuit current of a dominant state in a system fault.

During CAN communication, the bus switches between the dominant and recessive states. Thus, the short-circuit current may be viewed either as the current during each bus state or as an average current. The average short-circuit current can be used when considering system power for the termination resistors and common-mode choke. The percentage of time that the driver can be dominant is limited by the TXD dominant state timeout and the CAN protocol which has forced state changes and recessive bits such as bit stuffing, control fields, and interframe spacing. These make sure there is a minimum recessive time on the bus even if the data field contains a high percentage of dominant bits.

The short-circuit current of the bus depends on the ratio of recessive to dominant bits and the respective short-circuit currents. The average short-circuit current may be calculated using [式 2](#).

$$I_{OS(AVG)} = \%Transmit \times [(\%REC_Bits \times I_{OS(SS)_REC}) + (\%DOM_Bits \times I_{OS(SS)_DOM})] + [\%Receive \times I_{OS(SS)_REC}] \quad (2)$$

Where:

- I_{OS(AVG)} is the average short-circuit current
- %Transmit is the percentage the node is transmitting CAN messages
- %Receive is the percentage the node is receiving CAN messages
- %REC_Bits is the percentage of recessive bits in the transmitted CAN messages
- %DOM_Bits is the percentage of dominant bits in the transmitted CAN messages
- I_{OS(SS)_REC} is the recessive steady state short-circuit current

表 7-4. TCAN1043N-Q1 Mode Overview

MODE	V _{CC} and V _{IO}	V _{SUP}	EN	nSTB	WAKERQ FLAG	DRIVER	RECEIVER	RXD	INH
Normal	> UV _{CC} and > UV _{IO}	> UV _{SUP}	High	High	X	Enabled	Enabled	Mirrors bus state	On
Silent	> UV _{CC} and > UV _{IO}	> UV _{SUP}	Low	High	X	Disabled	Enabled	Mirrors bus state	On
Standby	> UV _{CC} and > UV _{IO}	> UV _{SUP}	High	Low	Set	Disabled	Low power bus monitor enabled	Low signals wake-up	On
	> UV _{CC} and > UV _{IO}	> UV _{SUP}	Low	Low	X	Disabled	Low power bus monitor enabled	Low signals wake-up	On
	> UV _{CC} and < UV _{IO}	> UV _{SUP}	Low	Low	X	Disabled	Low power bus monitor enabled	High impedance	On
Go-to-sleep ⁽¹⁾	> UV _{CC} and > UV _{IO}	> UV _{SUP}	High	Low	Cleared	Disabled	Low power bus monitor enabled	High or high impedance (no V _{IO})	On ⁽²⁾
Sleep ⁽³⁾	> UV _{CC} and > UV _{IO}	> UV _{SUP}	High	Low	Cleared	Disabled	Low power bus monitor enabled	High or high impedance (no V _{IO})	High Impedance
	< UV _{CC} or < UV _{IO}	> UV _{SUP}	X	X	X	Disabled	Low power bus monitor enabled	High or high impedance (no V _{IO})	High impedance
Protected	X	< UV _{SUP}	X	X	X	Disabled	Disabled	High impedance	High impedance

(1) Go-to-sleep: Transitional mode for EN = H, nSTB = L until t_{GOTOSLEEP} timer has expired.

(2) The INH pin transitions to high impedance after the t_{GOTOSLEEP} timer has expired.

(3) Mode change from go-to-sleep mode to sleep mode once t_{GOTOSLEEP} timer has expired.

7.4.1 Operating Mode Description

7.4.1.1 Normal Mode

This is the normal operating mode of the device. The CAN driver and receiver are fully operational and CAN communication is bi-directional. The driver is translating a digital input on TXD to a differential output on CANH and CANL. The receiver is translating the differential signal from CANH and CANL to a digital output on RXD.

Entering normal mode clears both the WAKERQ and the PWRON flags.

7.4.1.2 Silent Mode

Silent mode is commonly referred to as listen only and receive only mode. In this mode, the CAN driver is disabled but the receiver is fully operational and CAN communication is unidirectional into the device. The receiver is translating the differential signal from CANH and CANL to a digital output on the RXD terminal.

In silent mode, PWRON and Local Failure flags are indicated on the nFAULT pin.

7.4.1.3 Standby Mode

Standby mode is a low-power mode where the driver and receiver are disabled, reducing current consumption. However, this is not the lowest power mode of the device since the INH terminal is on, allowing the rest of the system to resume normal operation.

During standby mode, a wake-up request (WAKERQ) is indicated by the RXD terminal being low. The wake-up source is identified via the nFAULT pin after the device is returned to normal mode.

7.4.1.4 Go-To-Sleep Mode

Go-to-sleep mode is the transitional mode of the device from any state to sleep. In this state the driver and receiver are disabled, reducing the current consumption. The INH pin is active to supply an enable to the V_{IO} controller which allows the rest of the system to operate normally. If the device is held in this state for t ≥ t_{GOTOSLEEP} the device transitions to sleep mode and the INH turns off transitioning to the high impedance state.

If any wake-up events persist, the TCAN1043N-Q1 remains in standby mode until the device is switched into normal mode to clear the pending wake-up events.

7.4.1.5 Sleep Mode

Sleep mode is the lowest power mode of the TCAN1043N-Q1. In sleep mode, the CAN transmitter and the main receiver are switched off and the transceiver cannot send or receive data. The low power receiver is able to monitor the bus for any activity that validates the wake-up pattern (WUP) requirements, and the WAKE monitoring circuit monitors for state changes on the WAKE terminal for a local wake-up (LWU) event. I_{SUP}

current is reduced to the minimum level when the CAN transceiver is in CAN autonomous inactive state. The INH pin is switched off in sleep mode causing any system power supplies controlled by INH to be switched off thus reducing system power consumption.

Sleep mode is exited:

- If a valid wake-up pattern (WUP) is received via the CAN bus pins
- On a local WAKE (LWU) event
- nSTB is high and $V_{CC} > UV_{CC}$ and $V_{IO} > UV_{IO}$ (the device enters Normal or Silent mode depending upon the logic level on the EN pin).

7.4.1.5.1 Remote Wake Request via Wake-Up Pattern (WUP)

The TCAN1043N-Q1 implements a low-power wake receiver in the standby and sleep mode that uses the multiple filtered dominant wake-up pattern (WUP) defined in the ISO11898-2:2024 standard.

The wake-up pattern (WUP) consists of a filtered dominant bus, then a filtered recessive bus time followed by a second filtered dominant bus time. The first filtered dominant initiates the WUP and the bus monitor is now waiting on a filtered recessive; other bus traffic will not reset the bus monitor. Once a filtered recessive is received, the bus monitor is now waiting on a filtered dominant, and other bus traffic does not reset the bus monitor. Immediately upon receiving of the second filtered dominant, the bus monitor recognizes the WUP, and drives the RXD terminal low. If a valid V_{IO} is present, the controller is signaled for a wake-up request. If a valid V_{IO} is not present when the wake-up pattern is received, the transceiver drives the RXD output pin low once $V_{IO} > UV_{IOR}$.

The WUP consists of:

- A filtered dominant bus of at least $t_{WK(FILTER)}$ followed by
- A filtered recessive bus time of at least $t_{WK(FILTER)}$ followed by
- A second filtered dominant bus time of at least $t_{WK(FILTER)}$

For a dominant or recessive to be considered *filtered*, the bus must be in that state for more than $t_{WK(FILTER)}$ time. Due to variability in the $t_{WK(FILTER)}$, the following scenarios are applicable. Bus state times less than the $t_{WK(FILTER)}$ minimum are never detected as part of a WUP, and no wake request is generated. Bus state times between $t_{WK(FILTER)}$ minimum and $t_{WK(FILTER)}$ maximum may be detected as part of a WUP and a wake request may be generated. Bus state times more than $t_{WK(FILTER)}$ maximum is always detected as part of a WUP, and a wake request is always generated. See [Figure 7-5](#) for the timing diagram of the WUP.

The pattern and $t_{WK(FILTER)}$ time used for the WUP and wake request prevents noise and bus stuck dominant faults from causing false wake requests while allowing any CAN or CAN FD message to initiate a wake request.

ISO11898-2:2024 has two sets of times for a short and long wake-up filter times. The $t_{WK(FILTER)}$ timing for the TCAN1043N-Q1 has been picked to be within the min and max values of both filter ranges. This timing has been chosen such that a single bit time at 500kbps, or two back to back bit times at 1Mbps triggers the filter in either bus state.

For an additional layer of robustness and to prevent false wake-ups, the transceiver implements the $t_{WK(TIMEOUT)}$ timer. For a remote wake-up event to successfully occur, the entire wake-up pattern must be received within the timeout value. If the full wake-up pattern is not received before the $t_{WK(TIMEOUT)}$ expires then the internal logic is reset and the transceiver remains in sleep mode without waking up. The full pattern must then be transmitted again within the $t_{WK(TIMEOUT)}$ window. See [Figure 7-5](#).

A recessive bus of at least $t_{WK(FILTER)}$ must separate the next WUP pattern if the CAN bus is dominant when the $t_{WK(TIMEOUT)}$ expires.

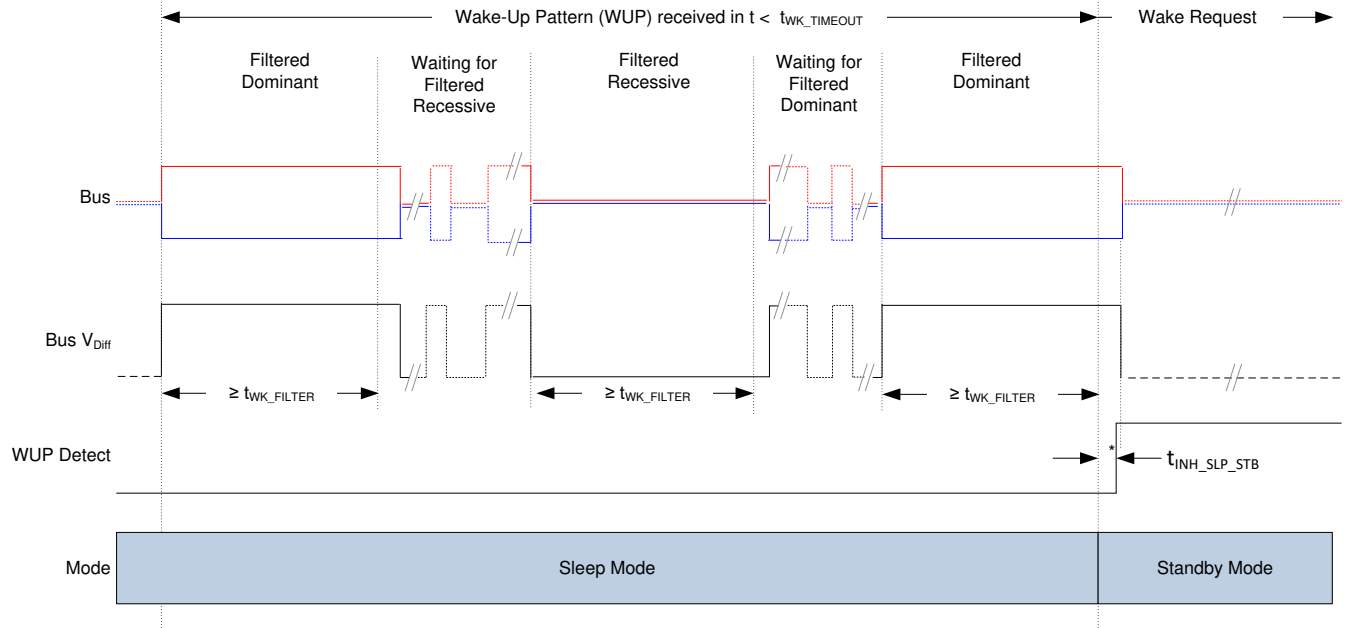

*The RXD pin is only driven once V_{IO} is present.

図 7-5. Wake-Up Pattern (WUP)

7.4.1.5.2 Local Wake-Up (LWU) via WAKE Input Terminal

The WAKE terminal is a bi-directional high-voltage reverse-battery protected input which can be used for local wake-up (LWU) requests via a voltage transition. A LWU event is triggered on either a low-to-high or high-to-low transition since the terminal has bi-directional input thresholds. The WAKE pin could be used with a switch to V_{SUP} or to ground. Unused terminals should be pulled to V_{SUP} or ground to avoid unwanted parasitic wake-up events.



図 7-6. WAKE Circuit Example

図 7-6 shows two possible configurations for the WAKE pin, a low-side and high-side switch configuration. The objective of the series resistor, R_{SERIES}, is to protect the WAKE input of the device from over current conditions that may occur in the event of a ground shift or ground loss. The minimum value of R_{SERIES} can be calculated using the maximum supply voltage, V_{SUPMAX}, and the maximum allowable current of the WAKE pin, I_{IO(WAKE)}. R_{SERIES} is calculated using:

$$R_{SERIES} = V_{SUPMAX} / I_{IO(WAKE)} \quad (3)$$

With absolute maximum voltage, V_{SUPMAX} , of 45V and maximum allowable $I_{IO(WAKE)}$ of 3mA, the minimum required R_{SERIES} value is 15k Ω .

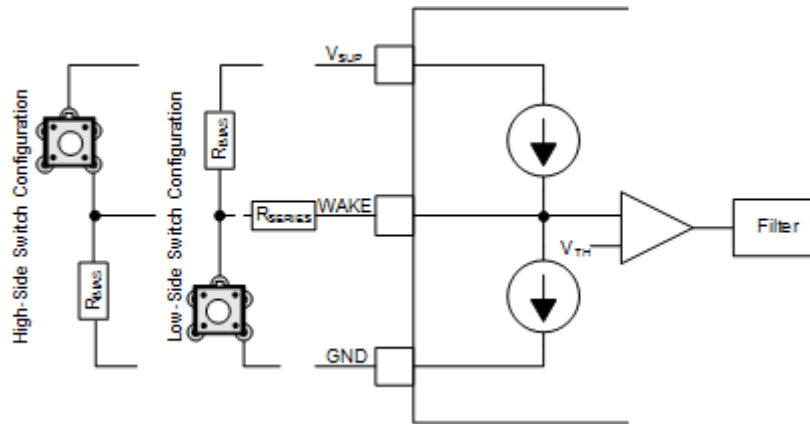
The R_{BIAS} resistor is used to set the static voltage level of the WAKE input when the switch is released. When the switch is in use in a high-side switch configuration, the R_{BIAS} resistor in combination with the R_{SERIES} resistor sets the WAKE pin voltage above the V_{IH} threshold. The maximum value of R_{BIAS} can be calculated using the maximum supply voltage, V_{SUPMAX} , the maximum WAKE threshold voltage V_{IH} , the maximum WAKE input current I_{IH} and the series resistor value R_{SERIES} . R_{BIAS} is calculated using:

$$R_{BIAS} < ((V_{SUPMAX} - V_{IH}) / I_{IH}) - R_{SERIES} \quad (4)$$

With V_{SUPMAX} of 45V, V_{IH} of 44V at I_{IH} of 3 μ A, the R_{BIAS} resistor value must be less than 330k Ω . The recommendation is to use R_{SERIES} less than 50k Ω to provide better margin for the WAKE pin voltage to rise above V_{IH} when the switch is released.

The LWU circuitry is active in sleep mode.

The WAKE circuitry is switched off in normal mode.

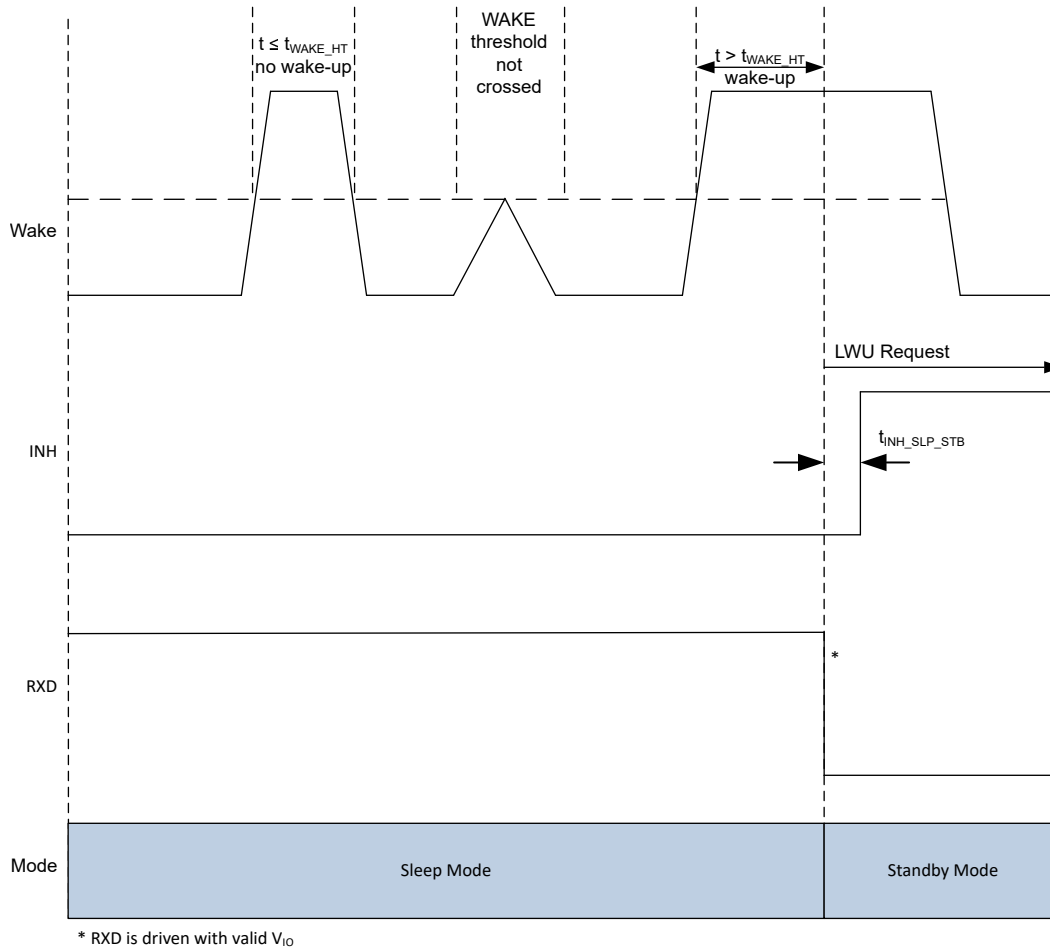

7-7. LWU Request Rising Edge

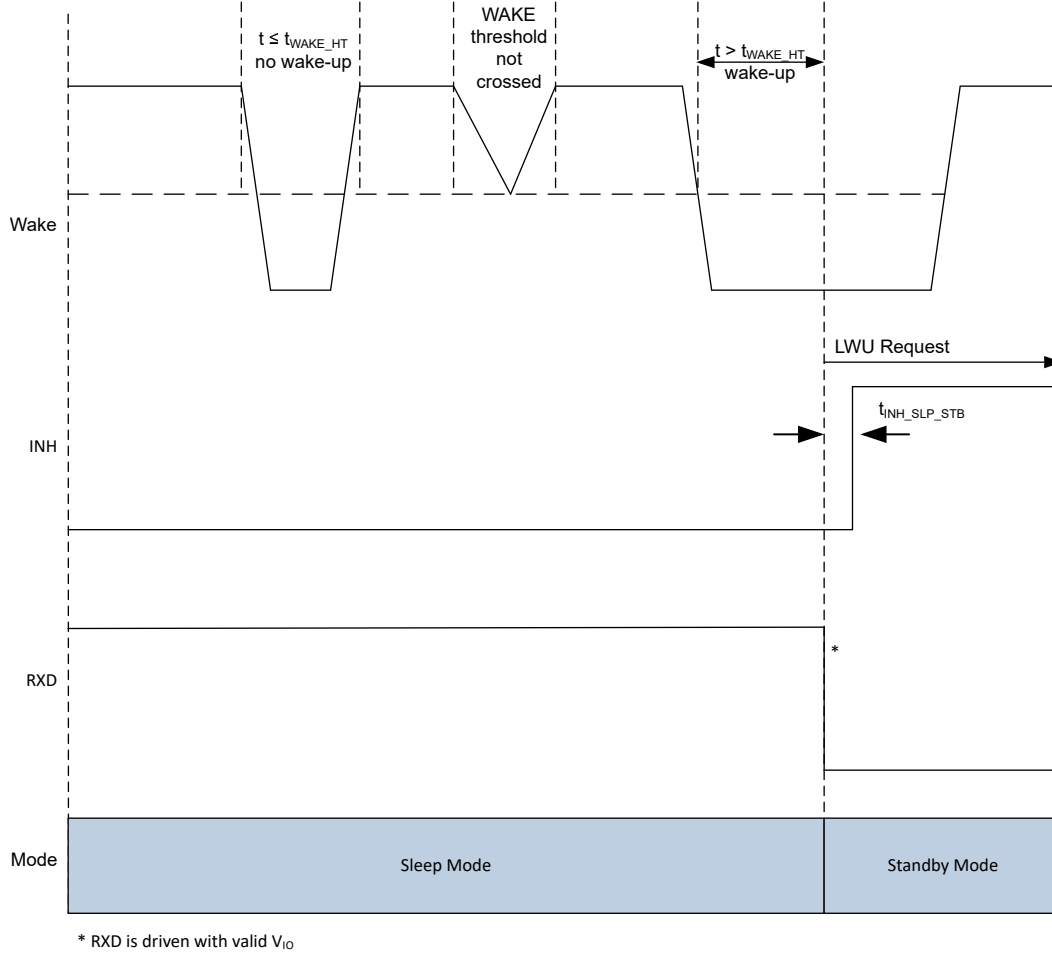

7-8. LWU Request Falling Edge

7.4.2 CAN Transceiver

7.4.2.1 CAN Transceiver Operation

The TCAN1043N-Q1 supports the ISO 11898-2:2024 CAN physical layer standard autonomous bus biasing scheme. Autonomous bus biasing enables the transceiver to switch between CAN active, CAN autonomous active, and CAN autonomous inactive which helps to reduce RF emissions.

7.4.2.1.1 CAN Transceiver Modes

The TCAN1043N-Q1 CAN transceiver has four modes of operation; CAN off, CAN autonomous active, CAN autonomous inactive and CAN active.

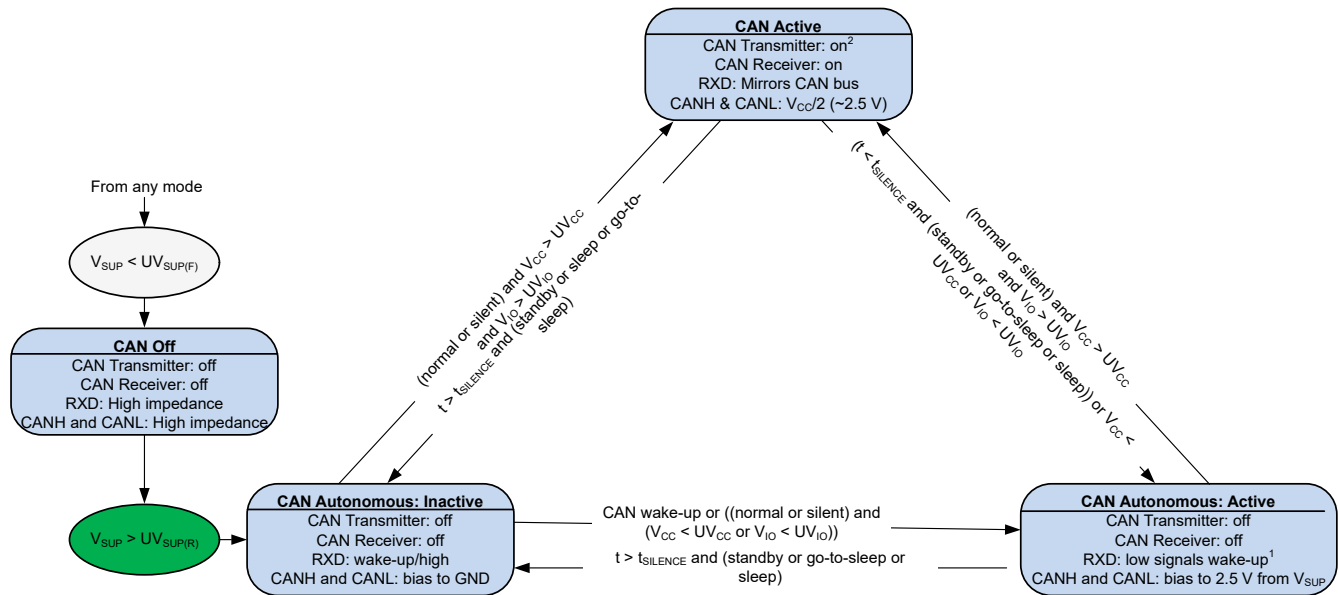

1. Wake-up is inactive in normal or silent mode.
2. CAN transmitter is off in silent mode.

7-9. TCAN1043N-Q1 CAN Transceiver State Machine

7.4.2.1.1.1 CAN Off Mode

In CAN off mode the CAN transceiver is switched off and the CAN bus lines are truly floating. In this mode the device presents no load to the CAN bus while preventing reverse currents from flowing into the device if the battery or ground connection is lost.

The CAN off state is entered if:

- $V_{SUP} < UV_{SUP(F)}$

The CAN transceiver switches between the CAN off state and CAN autonomous inactive mode if:

- $V_{SUP} > UV_{SUP(R)}$

7.4.2.1.1.2 CAN Autonomous: Inactive and Active

When the CAN transceiver is in standby, go-to-sleep or sleep mode, the bias circuit can be in either the CAN autonomous inactive or CAN autonomous active state. In the autonomous inactive state, the CAN pins are biased to GND. When a remote wake-up (WUP) event occurs, the CAN bus is biased to 2.5V and the CAN transceiver enters the CAN autonomous active state. If the controller does not transition the transceiver into normal mode before the $t_{SILENCE}$ timer expires, the CAN transceiver enters the CAN autonomous inactive state.

The CAN transceiver switches to the CAN autonomous mode if any of the following conditions are met:

- The operating mode changes from CAN off mode to CAN autonomous inactive
- The operating mode changes from normal or silent mode to standby, go-to-sleep, or sleep mode:
 - If the bus was inactive for $t < t_{SILENCE}$ before the mode change, the transceiver enters autonomous active state
 - If the bus was inactive for $t > t_{SILENCE}$ before the mode change, the transceiver enters autonomous inactive state
- $V_{CC} < UV_{CC(F)}$
- $V_{IO} < UV_{IO(F)}$

The CAN transceiver switches from the CAN autonomous inactive mode to the CAN autonomous active mode if:

- A remote wake-up event occurs
- The transceiver transitions to normal or silent mode and $V_{CC} < UV_{CC(F)}$ or $V_{IO} < UV_{IO(F)}$

The CAN transceiver switches from the CAN autonomous active mode to the CAN autonomous inactive mode if:

- The transceiver is in standby, go-to-sleep, or sleep mode and $t > t_{\text{SILENCE}}$

7.4.2.1.1.3 CAN Active

When the transceiver is in normal or silent mode, the CAN transceiver is in active mode. In normal mode, the CAN driver and receiver are fully operational and CAN communication is bi-directional. In silent mode, the CAN driver is off but the CAN receiver is fully operational. The CAN bias voltage in CAN active mode is derived from V_{CC} and is held at $V_{\text{CC}}/2$

The CAN transceiver switches from the CAN autonomous inactive or CAN autonomous active modes to the CAN active mode if:

- The transceiver transitions to normal mode and $V_{\text{CC}} > UV_{\text{CC(R)}}$, $V_{\text{IO}} > UV_{\text{IO(R)}}$

The CAN transceiver switches from the CAN active mode to the CAN autonomous inactive mode if:

- The transceiver switches to standby, go-to-sleep, or sleep modes and $t > t_{\text{SILENCE}}$

The CAN transceiver switches from the CAN active mode to the CAN autonomous active mode if:

- The transceiver switches to standby, go-to-sleep, or sleep modes and $t < t_{\text{SILENCE}}$
- $V_{\text{CC}} < UV_{\text{CC(F)}}$
- $V_{\text{IO}} < UV_{\text{IO(F)}}$

7.4.2.1.2 Driver and Receiver Function Tables

表 7-5. Driver Function Table

DEVICE MODE	TXD INPUTS ⁽¹⁾	BUS OUTPUTS		DRIVEN BUS STATE ⁽²⁾
		CANH	CANL	
Normal	Low	High	Low	Dominant
	High or Open	High impedance	High impedance	$V_{\text{CC}}/2$
Silent	x	High impedance	High impedance	$V_{\text{CC}}/2$
Standby	x	High impedance	High impedance	Autonomous biasing
Sleep	x	High impedance	High impedance	Autonomous biasing

(1) x = irrelevant

(2) For bus states and typical bus voltages see 図 7-10.

表 7-6. Receiver Function Table

DEVICE MODE	CAN DIFFERENTIAL INPUTS $V_{\text{ID}} = V_{\text{CANH}} - V_{\text{CANL}}$	BUS STATE	RXD TERMINAL
Normal / Silent	$V_{\text{ID}} \geq 0.9 \text{ V}$	Dominant	Low
	$0.5 \text{ V} < V_{\text{ID}} < 0.9 \text{ V}$	Indeterminate	Indeterminate
	$V_{\text{ID}} \leq 0.5 \text{ V}$	Recessive	High
	Open ($V_{\text{ID}} \approx 0 \text{ V}$)	Open	High
Standby	$V_{\text{ID}} \geq 1.15 \text{ V}$	Dominant	High Low if wake-up event persists
	$0.4 \text{ V} < V_{\text{ID}} < 1.15 \text{ V}$	Indeterminate	
	$V_{\text{ID}} \leq 0.4$	Recessive	
	Open ($V_{\text{ID}} \approx 0 \text{ V}$)	Open	
Sleep / Go-to-sleep ⁽¹⁾	$V_{\text{ID}} \geq 1.15 \text{ V}$	Dominant	High Tri-state if V_{IO} or V_{SUP} are not present
	$0.4 \text{ V} < V_{\text{ID}} < 1.15 \text{ V}$	Indeterminate	
	$V_{\text{ID}} \leq 0.4 \text{ V}$	Recessive	
	Open ($V_{\text{ID}} \approx 0 \text{ V}$)	Open	

(1) Low power wake-up receiver is active

7.4.2.1.3 CAN Bus States

The CAN bus has two logical states during operation: recessive and dominant. See [7-10](#).

A dominant bus state occurs when the bus is driven differentially and corresponds to a logic low on the TXD and RXD pins. A recessive bus state occurs when the bus is biased to one half of the CAN transceiver supply voltage via the high resistance internal input resistors (R_{IN}) of the receiver and corresponds to a logic high on the TXD and RXD pins.

A dominant state overwrites the recessive state during arbitration. Multiple CAN nodes may be transmitting a dominant bit at the same time during arbitration when the differential voltage of the CAN bus is greater than the differential voltage of a single CAN driver. The TCAN1043N-Q1 CAN transceiver implements low-power standby modes which enable a third bus state where, if the CAN bus is inactive for $t > t_{SILENCE}$. The bus pins are biased to ground via the high-resistance internal resistors of the receiver.

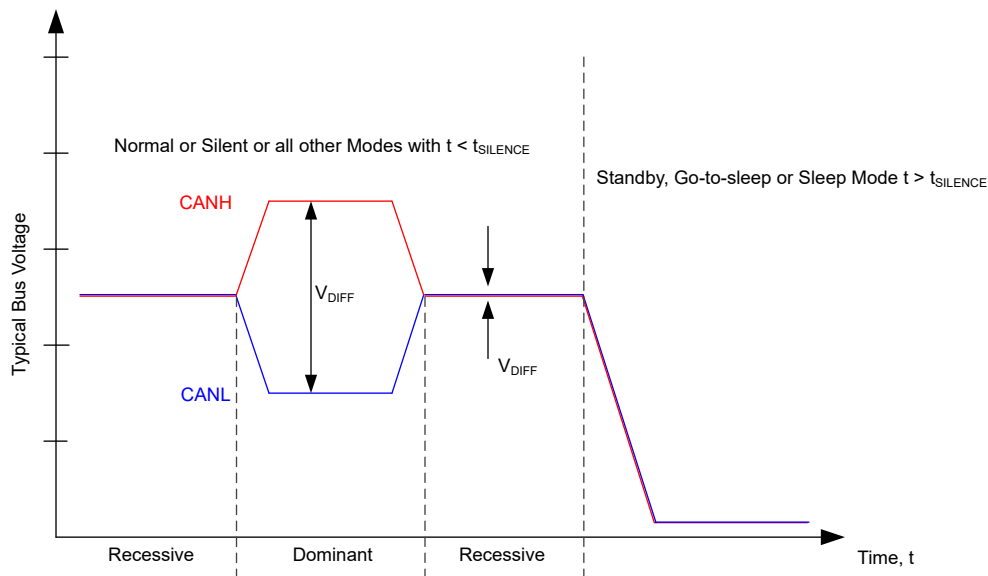

7-10. Bus States

8 Application Information Disclaimer

注

Information in the following applications sections is not part of the TI component specification, and TI does not warrant its accuracy or completeness. TI's customers are responsible for determining suitability of components for their purposes, as well as validating and testing their design implementation to confirm system functionality.

8.1 Application Information

The TCAN1043N-Q1 transceiver is typically used in applications with a host microprocessor or FPGA that includes the data link layer portion of the CAN protocol. These types of applications usually also include power management technology that allows for power to be gated to the application via an enable (EN) or inhibit (INH) pin. A single 5V regulator can be used to drive both V_{CC} and V_{IO} , or independent 5V and 3.3V regulators can be used to drive V_{CC} and V_{IO} separately as shown in 8-1. The bus termination is shown for illustrative purposes.

8.1.1 Typical Application

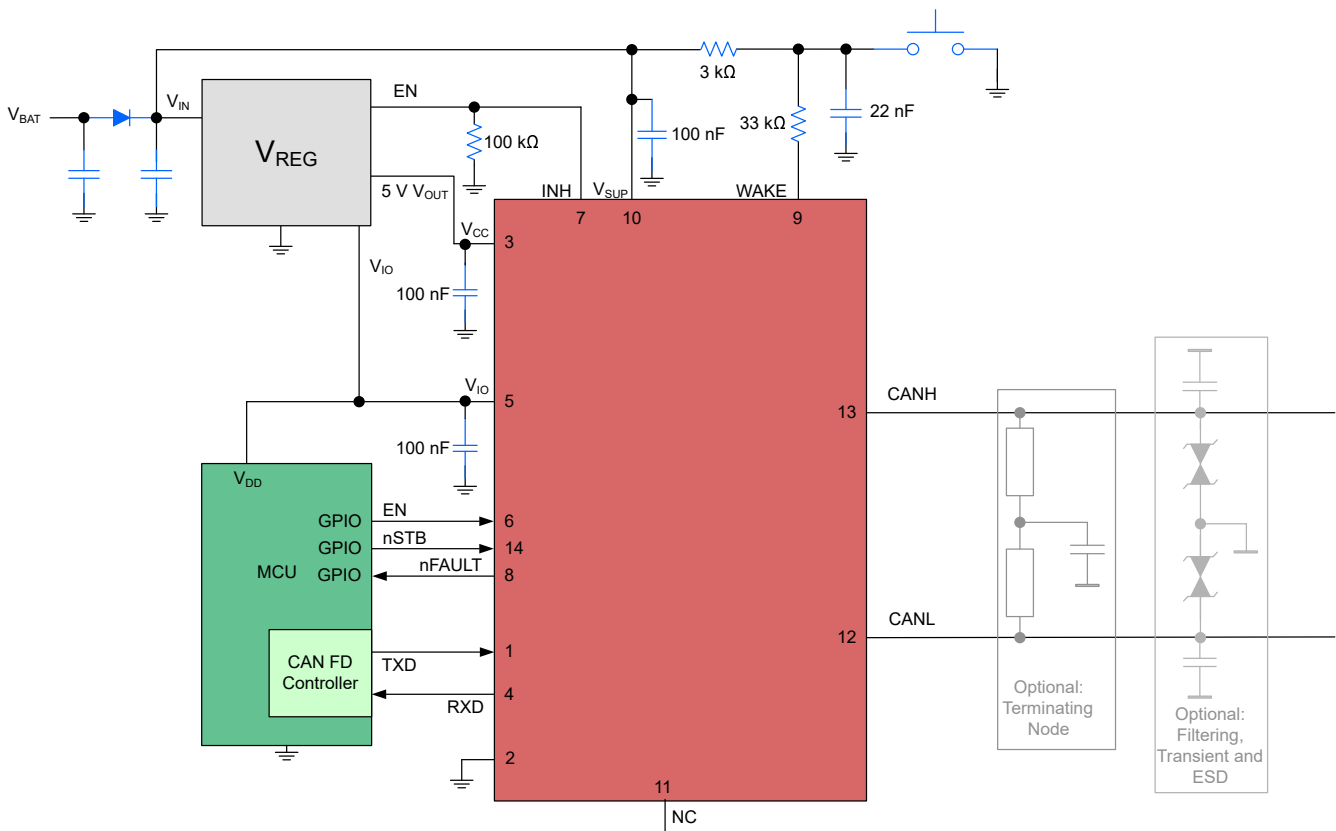

8-1. Typical Application

8.1.2 Design Requirements

8.1.2.1 Bus Loading, Length and Number of Nodes

A typical CAN application may have a maximum bus length of 40 meters and maximum stub length of 0.3m. However, with careful design, users can have longer cables, longer stub lengths, and many more nodes to a bus. A high number of nodes requires a transceiver with high input impedance such as the TCAN1043N-Q1.

Many CAN organizations and standards have scaled the use of CAN for applications outside the original ISO11898-2:2024 standard. They made system level trade off decisions for data rate, cable length, and parasitic loading of the bus. Examples of these CAN systems level specifications are ARINC825, CANopen, DeviceNet, SAEJ2284, SAEJ1939, and NMEA200.

A CAN network system design is a series of tradeoffs. In the ISO 11898-2:2024 specification the differential output driver is specified with a bus load that can range from 50Ω to 65Ω where the differential output must be greater than 1.5V. The TCAN1043N-Q1 is specified to meet the 1.5V requirement down to 50Ω and is specified to meet 1.4V differential output at 45Ω bus load. The differential input resistance, R_{ID} , of the TCAN1043N-Q1 is a minimum of $50k\Omega$. If 100 TCAN1043N-Q1 transceivers are in parallel on a bus, this is equivalent to a 500Ω differential load in parallel with the nominal 60Ω bus termination which gives a total bus load of approximately 54Ω . Therefore, the TCAN1043N-Q1 theoretically supports over 100 transceivers on a single bus segment. However, for CAN network design margin must be given for signal loss across the system and cabling, parasitic loadings, timing, network imbalances, ground offsets and signal integrity thus a practical maximum number of nodes is often lower. Bus length may also be extended beyond 40 meters by careful system design and data rate tradeoffs. For example, CANopen network design guidelines allow the network to be up to 1km with changes in the termination resistance, cabling, less than 64 nodes and significantly lowered data rate.

This flexibility in CAN network design is one of the key strengths allowing for these system level network extensions and additional standards to build on the original ISO11898-2 CAN standard. However, when using this flexibility, the CAN network system designer must take the responsibility of good network design for a robust network operation.

8.1.3 Detailed Design Procedure

8.1.3.1 CAN Termination

Termination may be a single 120Ω resistor at each end of the bus, either on the cable or in a terminating node. If filtering and stabilization of the common-mode voltage of the bus is desired then split termination may be used, see [8-2](#). Split termination improves the electromagnetic emissions behavior of the network by filtering higher-frequency common-mode noise that may be present on the differential signal lines.

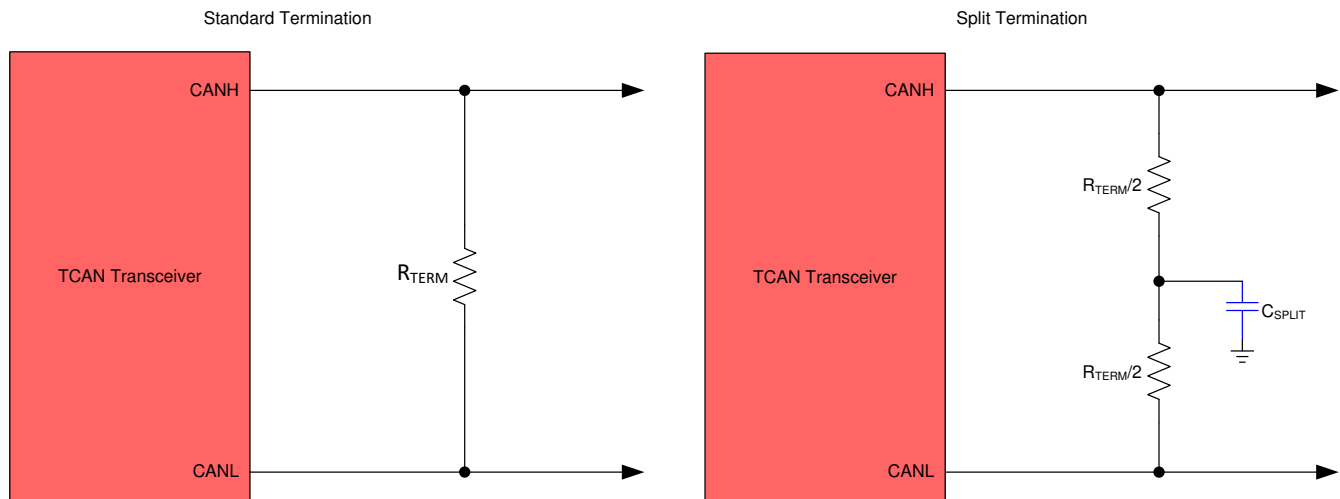

8-2. CAN Bus Termination Concepts

8.1.4 Application Curves



图 8-3. I_{CC} Dominant over I_{CC} Supply Voltage

8.2 Power Supply Recommendations

The TCAN1043N-Q1 is designed to operate off of three supply rails; V_{SUP} , V_{CC} , and V_{IO} . V_{SUP} is a high-voltage supply pin designed to connect to the V_{BAT} rail, V_{CC} is a low-voltage supply pin with an input voltage range from 4.5V to 5.5V that supports the CAN transceiver and V_{IO} is a low-voltage supply pin with an input voltage range from 1.7V to 5.5V that provides the I/O voltage to match the system controller. For a reliable operation, a 100nF decoupling capacitor should be placed as close to the supply pins as possible. This helps to reduce supply voltage ripple present on the output of switched-mode power supplies, and also helps to compensate for the resistance and inductance of the PCB power planes.

8.3 Layout

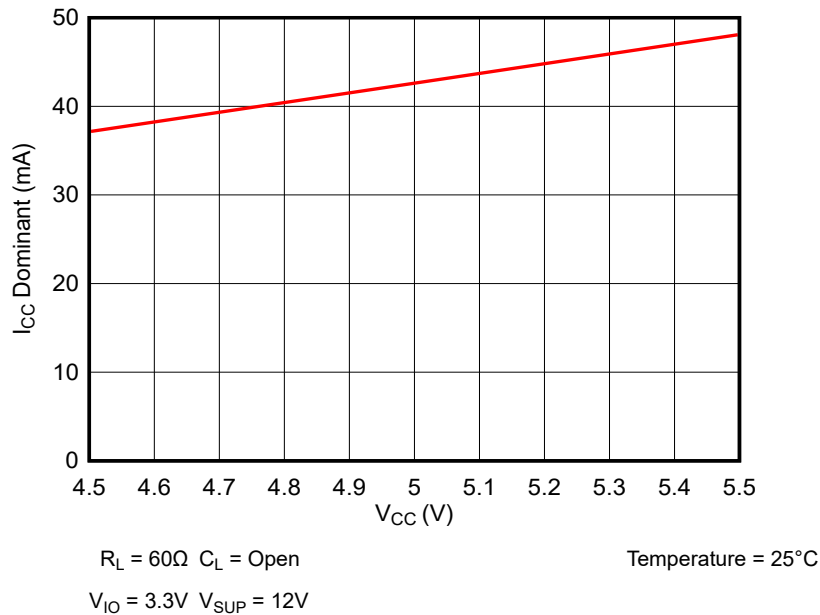
Robust and reliable CAN node design may require special layout techniques depending on the application and automotive design requirements. Since transient disturbances have high frequency content and a wide bandwidth, high-frequency layout techniques should be applied during PCB design.

8.3.1 Layout Guidelines

The layout example provides information on components around the device. Place the protection and filtering circuitry as close to the bus connector, J1, to prevent transients, ESD and noise from propagating onto the board. Transient voltage suppression (TVS) device can be added for extra protection, shown as D1. The production solution can be either a bi-directional TVS diode or varistor with ratings matching the application requirements. This example also shows optional bus filter capacitors C6 and C7. A series common-mode choke (CMC) is placed on the CANH and CANL lines between the device and connector J1.

Design the bus protection components in the direction of the signal path. Do not force the transient current to divert from the signal path to reach the protection device. Use supply and ground planes to provide low inductance. Note that high-frequency currents follow the path of least impedance and not the path of least resistance. Use at least two vias for supply and ground connections of bypass capacitors and protection devices to minimize trace and via inductance.

- Bypass and bulk capacitors should be placed as close as possible to the supply terminals of transceiver, examples are C1 on V_{CC} , C2 on V_{IO} , and C3 and C4 on the V_{SUP} supply.

9 Device and Documentation Support

9.1 Documentation Support

9.2 ドキュメントの更新通知を受け取る方法

ドキュメントの更新についての通知を受け取るには、www.tij.co.jp のデバイス製品フォルダを開いてください。[通知] をクリックして登録すると、変更されたすべての製品情報に関するダイジェストを毎週受け取ることができます。変更の詳細については、改訂されたドキュメントに含まれている改訂履歴をご覧ください。

9.3 サポート・リソース

テキサス・インスツルメンツ E2E™ サポート・フォーラムは、エンジニアが検証済みの回答と設計に関するヒントをエキスパートから迅速かつ直接得ることができる場所です。既存の回答を検索したり、独自の質問をしたりすることで、設計に必要な支援を迅速に得ることができます。

リンクされているコンテンツは、各寄稿者により「現状のまま」提供されるものです。これらはテキサス・インスツルメンツの仕様を構成するものではなく、必ずしもテキサス・インスツルメンツの見解を反映したものではありません。テキサス・インスツルメンツの[使用条件](#)を参照してください。

9.4 Trademarks

テキサス・インスツルメンツ E2E™ is a trademark of Texas Instruments.
すべての商標は、それぞれの所有者に帰属します。

9.5 静電気放電に関する注意事項



この IC は、ESD によって破損する可能性があります。テキサス・インスツルメンツは、IC を取り扱う際には常に適切な注意を払うことを推奨します。正しい取り扱いおよび設置手順に従わない場合、デバイスを破損するおそれがあります。

ESD による破損は、わずかな性能低下からデバイスの完全な故障まで多岐にわたります。精密な IC の場合、パラメータがわずかに変化するだけで公表されている仕様から外れる可能性があるため、破損が発生しやすくなっています。

9.6 用語集

[テキサス・インスツルメンツ用語集](#) この用語集には、用語や略語の一覧および定義が記載されています。

10 Revision History

資料番号末尾の英字は改訂を表しています。その改訂履歴は英語版に準じています。

Changes from Revision A (November 2024) to Revision B (December 2024)	Page
• ドキュメントのステータスを「事前情報」から「量産データ」に変更	1

11 Mechanical, Packaging, and Orderable Information

The following pages include mechanical, packaging, and orderable information. This information is the most current data available for the designated devices. This data is subject to change without notice and revision of this document. For browser-based versions of this data sheet, refer to the left-hand navigation.

PACKAGING INFORMATION

Orderable Device	Status (1)	Package Type	Package Drawing	Pins	Package Qty	Eco Plan (2)	Lead finish/ Ball material (6)	MSL Peak Temp (3)	Op Temp (°C)	Device Marking (4/5)	Samples
PTCAN1043NDRQ1	ACTIVE	SOIC	D	14	3000	TBD	Call TI	Call TI	-40 to 150		Samples
PTCAN1043NDYYRQ1	ACTIVE	SOT-23-THIN	DYY	14	3000	TBD	Call TI	Call TI	-40 to 150		Samples
TCAN1043NDMTRQ1	ACTIVE	VSON	DMT	14	3000	RoHS & Green	NIPDAU	Level-2-260C-1 YEAR	-40 to 150	TCAN 1043N	Samples

(1) The marketing status values are defined as follows:

ACTIVE: Product device recommended for new designs.

LIFEBUY: TI has announced that the device will be discontinued, and a lifetime-buy period is in effect.

NRND: Not recommended for new designs. Device is in production to support existing customers, but TI does not recommend using this part in a new design.

PREVIEW: Device has been announced but is not in production. Samples may or may not be available.

OBSELETE: TI has discontinued the production of the device.

(2) **RoHS:** TI defines "RoHS" to mean semiconductor products that are compliant with the current EU RoHS requirements for all 10 RoHS substances, including the requirement that RoHS substance do not exceed 0.1% by weight in homogeneous materials. Where designed to be soldered at high temperatures, "RoHS" products are suitable for use in specified lead-free processes. TI may reference these types of products as "Pb-Free".

RoHS Exempt: TI defines "RoHS Exempt" to mean products that contain lead but are compliant with EU RoHS pursuant to a specific EU RoHS exemption.

Green: TI defines "Green" to mean the content of Chlorine (Cl) and Bromine (Br) based flame retardants meet JS709B low halogen requirements of <=1000ppm threshold. Antimony trioxide based flame retardants must also meet the <=1000ppm threshold requirement.

(3) MSL, Peak Temp. - The Moisture Sensitivity Level rating according to the JEDEC industry standard classifications, and peak solder temperature.

(4) There may be additional marking, which relates to the logo, the lot trace code information, or the environmental category on the device.

(5) Multiple Device Markings will be inside parentheses. Only one Device Marking contained in parentheses and separated by a "~" will appear on a device. If a line is indented then it is a continuation of the previous line and the two combined represent the entire Device Marking for that device.

(6) Lead finish/Ball material - Orderable Devices may have multiple material finish options. Finish options are separated by a vertical ruled line. Lead finish/Ball material values may wrap to two lines if the finish value exceeds the maximum column width.

Important Information and Disclaimer:The information provided on this page represents TI's knowledge and belief as of the date that it is provided. TI bases its knowledge and belief on information provided by third parties, and makes no representation or warranty as to the accuracy of such information. Efforts are underway to better integrate information from third parties. TI has taken and continues to take reasonable steps to provide representative and accurate information but may not have conducted destructive testing or chemical analysis on incoming materials and chemicals. TI and TI suppliers consider certain information to be proprietary, and thus CAS numbers and other limited information may not be available for release.

In no event shall TI's liability arising out of such information exceed the total purchase price of the TI part(s) at issue in this document sold by TI to Customer on an annual basis.

TAPE AND REEL INFORMATION

QUADRANT ASSIGNMENTS FOR PIN 1 ORIENTATION IN TAPE

*All dimensions are nominal

Device	Package Type	Package Drawing	Pins	SPQ	Reel Diameter (mm)	Reel Width W1 (mm)	A0 (mm)	B0 (mm)	K0 (mm)	P1 (mm)	W (mm)	Pin1 Quadrant
TCAN1043NDMTRQ1	VSON	DMT	14	3000	330.0	12.4	3.3	4.8	1.2	8.0	12.0	Q1

TAPE AND REEL BOX DIMENSIONS

*All dimensions are nominal

Device	Package Type	Package Drawing	Pins	SPQ	Length (mm)	Width (mm)	Height (mm)
TCAN1043NDMTRQ1	VSON	DMT	14	3000	367.0	367.0	35.0



4224643/D 07/2024

NOTES:

1. All linear dimensions are in millimeters. Any dimensions in parenthesis are for reference only. Dimensioning and tolerancing per ASME Y14.5M.
2. This drawing is subject to change without notice.
3. This dimension does not include mold flash, protrusions, or gate burrs. Mold flash, protrusions, or gate burrs shall not exceed 0.15 per side.
4. This dimension does not include interlead flash. Interlead flash shall not exceed 0.50 per side.
5. Reference JEDEC Registration MO-345, Variation AB

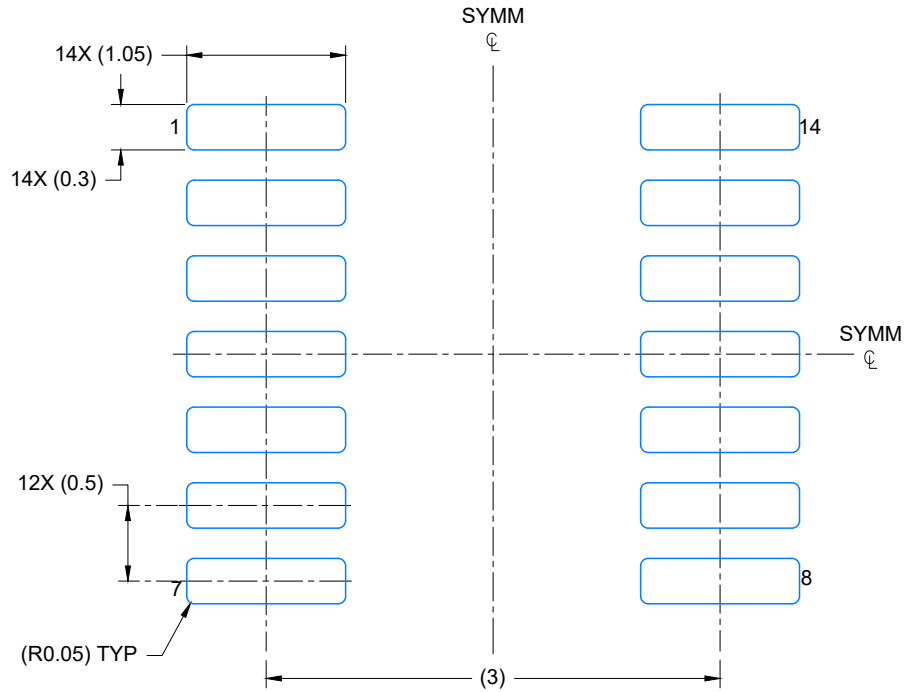

LAND PATTERN EXAMPLE
EXPOSED METAL SHOWN
SCALE: 20X

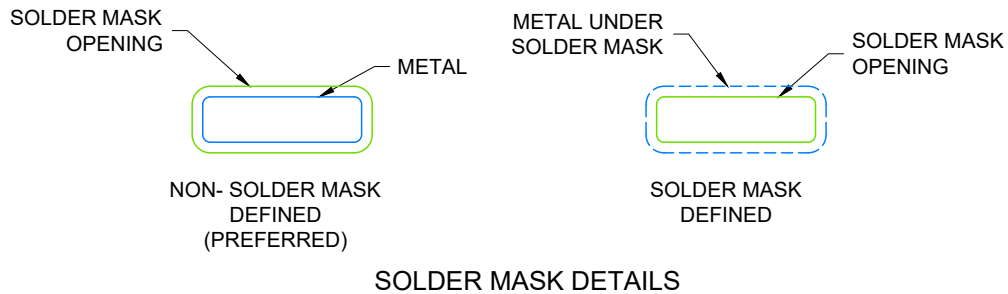

4224643/D 07/2024

NOTES: (continued)

- 6. Publication IPC-7351 may have alternate designs.
- 7. Solder mask tolerances between and around signal pads can vary based on board fabrication site.



NOTES: (continued)

8. Laser cutting apertures with trapezoidal walls and rounded corners may offer better paste release. IPC-7525 may have alternate design recommendations.
9. Board assembly site may have different recommendations for stencil design.



D0014A

PACKAGE OUTLINE

SOIC - 1.75 mm max height

SMALL OUTLINE INTEGRATED CIRCUIT



4220718/A 09/2016

NOTES:

1. All linear dimensions are in millimeters. Dimensions in parenthesis are for reference only. Dimensioning and tolerancing per ASME Y14.5M.
2. This drawing is subject to change without notice.
3. This dimension does not include mold flash, protrusions, or gate burrs. Mold flash, protrusions, or gate burrs shall not exceed 0.15 mm, per side.
4. This dimension does not include interlead flash. Interlead flash shall not exceed 0.43 mm, per side.
5. Reference JEDEC registration MS-012, variation AB.

EXAMPLE BOARD LAYOUT

D0014A

SOIC - 1.75 mm max height

SMALL OUTLINE INTEGRATED CIRCUIT



LAND PATTERN EXAMPLE
SCALE:8X



SOLDER MASK DETAILS

4220718/A 09/2016

NOTES: (continued)

- 6. Publication IPC-7351 may have alternate designs.
- 7. Solder mask tolerances between and around signal pads can vary based on board fabrication site.

EXAMPLE STENCIL DESIGN

D0014A

SOIC - 1.75 mm max height

SMALL OUTLINE INTEGRATED CIRCUIT



SOLDER PASTE EXAMPLE
BASED ON 0.125 mm THICK STENCIL
SCALE:8X

4220718/A 09/2016

NOTES: (continued)

8. Laser cutting apertures with trapezoidal walls and rounded corners may offer better paste release. IPC-7525 may have alternate design recommendations.
9. Board assembly site may have different recommendations for stencil design.

GENERIC PACKAGE VIEW

DMT 14

VSON - 0.9 mm max height

3 x 4.5, 0.65 mm pitch

PLASTIC SMALL OUTLINE - NO LEAD

This image is a representation of the package family, actual package may vary.
Refer to the product data sheet for package details.

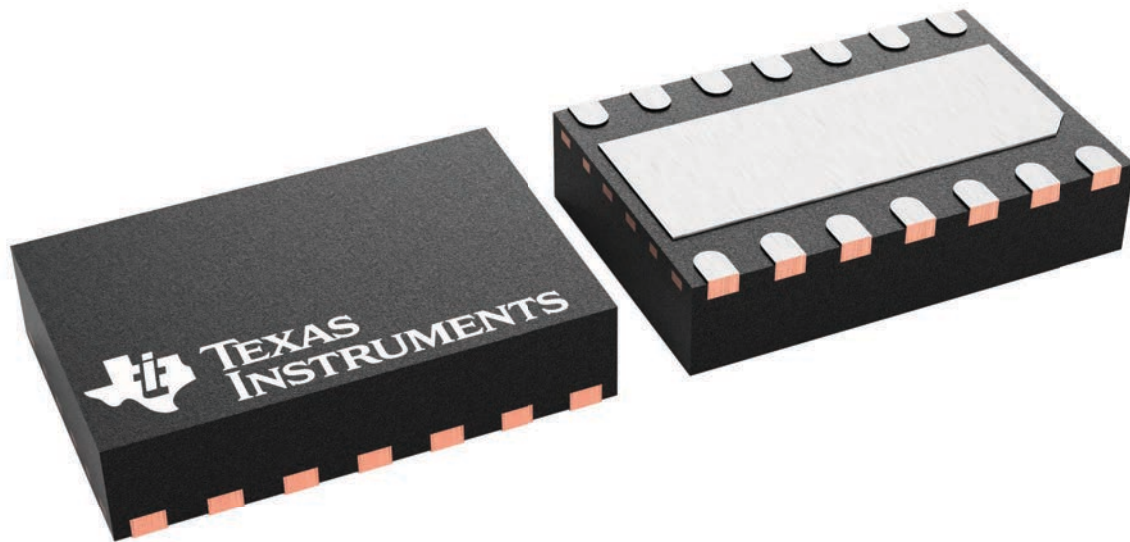

4225088/A

DMT0014B



PACKAGE OUTLINE

VSON - 1 mm max height

PLASTIC SMALL OUTLINE - NO LEAD

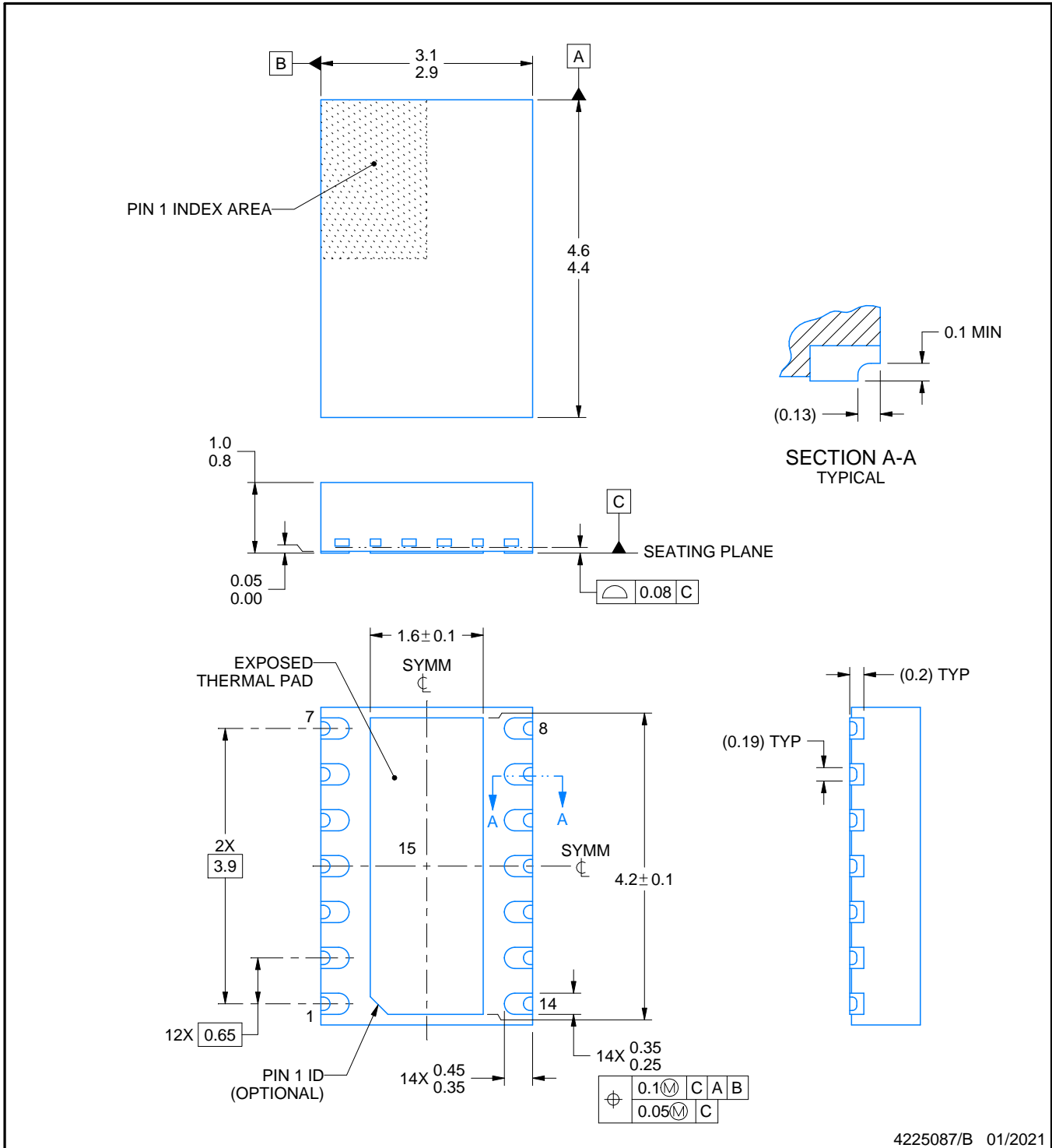

4225087/B 01/2021

NOTES:

1. All linear dimensions are in millimeters. Any dimensions in parenthesis are for reference only. Dimensioning and tolerancing per ASME Y14.5M.
2. This drawing is subject to change without notice.
3. The package thermal pad must be soldered to the printed circuit board for thermal and mechanical performance.

EXAMPLE BOARD LAYOUT

DMT0014B

VSON - 1 mm max height

PLASTIC SMALL OUTLINE - NO LEAD

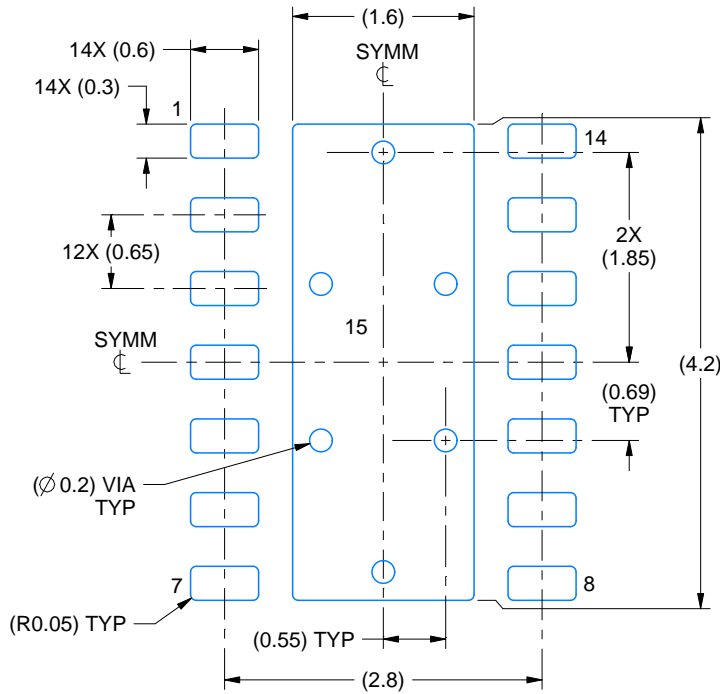

LAND PATTERN EXAMPLE
EXPOSED METAL SHOWN
SCALE:15X

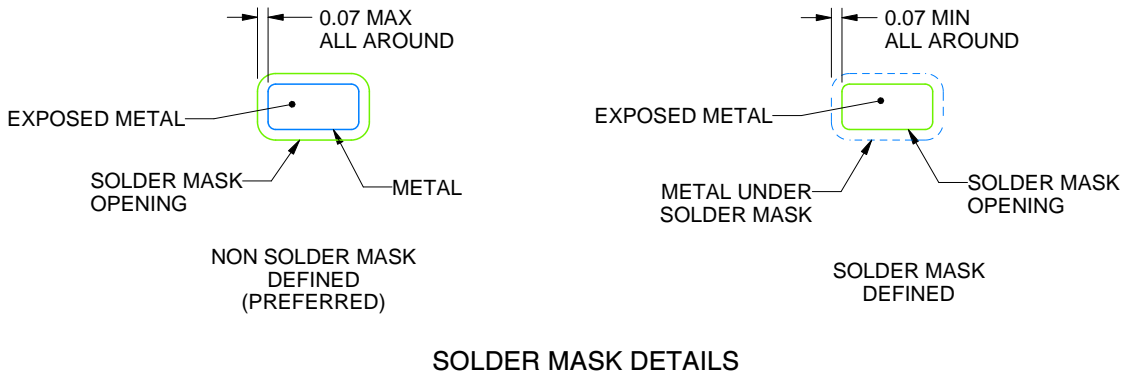

SOLDER MASK DETAILS

4225087/B 01/2021

NOTES: (continued)

4. This package is designed to be soldered to a thermal pad on the board. For more information, see Texas Instruments literature number SLUA271 (www.ti.com/lit/slúa271).
5. Vias are optional depending on application, refer to device data sheet. If any vias are implemented, refer to their locations shown on this view. It is recommended that vias under paste be filled, plugged or tented.

EXAMPLE STENCIL DESIGN

DMT0014B

VSON - 1 mm max height

PLASTIC SMALL OUTLINE - NO LEAD

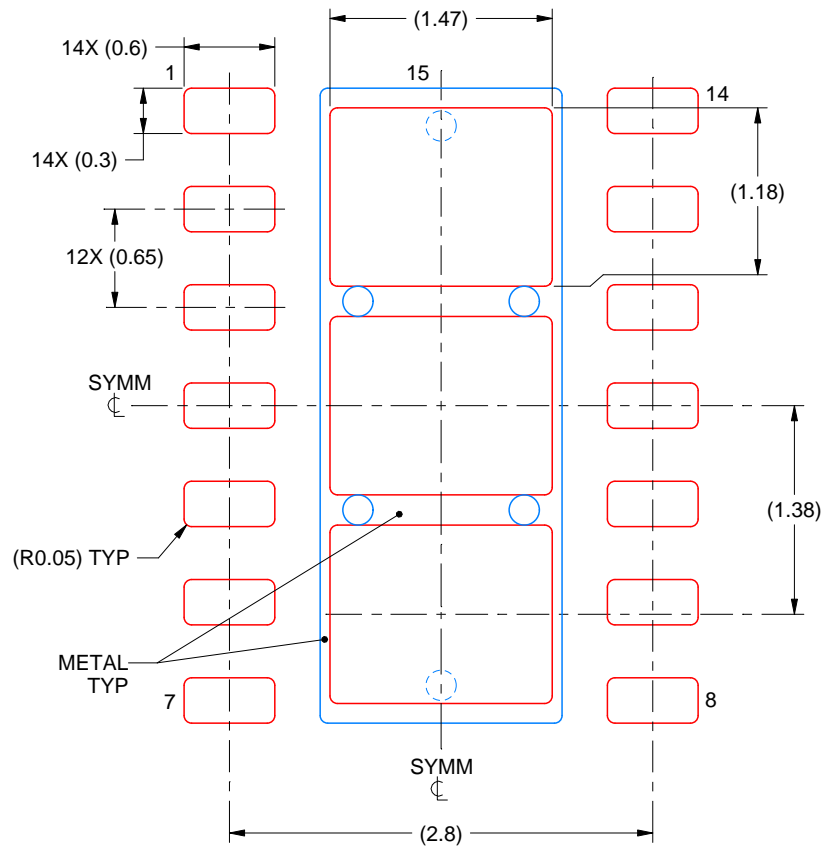

SOLDER PASTE EXAMPLE
BASED ON 0.125 mm THICK STENCIL
EXPOSED PAD 15
77.4% PRINTED SOLDER COVERAGE BY AREA
SCALE:20X

4225087/B 01/2021

NOTES: (continued)

6. Laser cutting apertures with trapezoidal walls and rounded corners may offer better paste release. IPC-7525 may have alternate design recommendations.

重要なお知らせと免責事項

テキサス・インスツルメンツは、技術データと信頼性データ(データシートを含みます)、設計リソース(リファレンス デザインを含みます)、アプリケーションや設計に関する各種アドバイス、Web ツール、安全性情報、その他のリソースを、欠陥が存在する可能性のある「現状のまま」提供しており、商品性および特定目的に対する適合性の黙示保証、第三者の知的財産権の非侵害保証を含むいかなる保証も、明示的または黙示的にかかわらず拒否します。

これらのリソースは、テキサス・インスツルメンツ製品を使用する設計の経験を積んだ開発者への提供を意図したものです。(1) お客様のアプリケーションに適したテキサス・インスツルメンツ製品の選定、(2) お客様のアプリケーションの設計、検証、試験、(3) お客様のアプリケーションに該当する各種規格や、その他のあらゆる安全性、セキュリティ、規制、または他の要件への確実な適合に関する責任を、お客様のみが単独で負うものとし、ます。

上記の各種リソースは、予告なく変更される可能性があります。これらのリソースは、リソースで説明されているテキサス・インスツルメンツ製品を使用するアプリケーションの開発の目的でのみ、テキサス・インスツルメンツはその使用をお客様に許諾します。これらのリソースに関して、他の目的で複製することや掲載することは禁止されています。テキサス・インスツルメンツや第三者の知的財産権のライセンスが付与されている訳ではありません。お客様は、これらのリソースを自身で使用した結果発生するあらゆる申し立て、損害、費用、損失、責任について、テキサス・インスツルメンツおよびその代理人を完全に補償するものとし、テキサス・インスツルメンツは一切の責任を拒否します。

テキサス・インスツルメンツの製品は、[テキサス・インスツルメンツの販売条件](#)、または [ti.com](https://www.ti.com) やかかるテキサス・インスツルメンツ製品の関連資料などのいずれかを通じて提供する適用可能な条項の下で提供されています。テキサス・インスツルメンツがこれらのリソースを提供することは、適用されるテキサス・インスツルメンツの保証または他の保証の放棄の拡大や変更を意味するものではありません。

お客様がいかなる追加条項または代替条項を提案した場合でも、テキサス・インスツルメンツはそれらに異議を唱え、拒否します。

郵送先住所：Texas Instruments, Post Office Box 655303, Dallas, Texas 75265
Copyright © 2025, Texas Instruments Incorporated