

## TDA4VH-Q1, TDA4AH-Q1, TDA4VP-Q1, TDA4AP-Q1 Jacinto™ プロセッサ、

### 1 特長

#### プロセッサ・コア:

- 最大 4 つ、最大 1.0GHz、320GFLOPS、1024GOPS の C7x 浮動小数点ベクタ DSP
- 最大 4 つ、最大 32TOPS (8b)、1.0GHz のディープラーニング用マトリクス乗算アクセラレータ (MMA)
- 画像信号プロセッサ (ISP) 搭載の 2 つのビジョン処理アクセラレータ (VPAC) と複数のビジョン支援アクセラレータ
- 深度およびモーション処理アクセラレータ (DMPAC)
- 8 つの最大 2.0GHz の Arm® Cortex®-A72 マイクロプロセッサ・サブシステム
  - クワッド・コア Cortex®-A72 クラスごとに 2MB の共有 L2 キャッシュ
  - Cortex®-A72 コアごとに 32KB L1 D キャッシュと 48KB L1 I キャッシュ
- 8 つの最大 1.0GHz の Arm® Cortex®-R5F MCU
  - 16K I キャッシュ、16K D キャッシュ、64K L2 TCM
  - 分離された MCU サブシステムに 2 つの Arm® Cortex®-R5F MCU
  - 汎用コンピューティング・パーティションに 6 つの Arm® Cortex®-R5F MCU
- GPU IMG BXS-4-64、256kB キャッシュ、最大 800MHz、50GFLOPS、4GTexels/s
- ほぼ最大限の処理権限をサポートするカスタム設計された相互接続構造

#### メモリ・サブシステム:

- 最大 8MB のオンチップ L3 RAM、ECC およびコヒーレンス機能付き
  - ECC エラー保護
  - 共有コヒーレント・キャッシュ
  - 内部 DMA エンジンをサポート
- 最大 4 つの外部メモリ・インターフェイス (EMIF) モジュール、ECC 付き
  - LPDDR4 メモリ・タイプをサポート
  - 最大 4266MT/s の速度をサポート
  - 最高 68GB/s、最大 4 本の 32 ビット・バス、インライン ECC 付き
- 汎用メモリ・コントローラ (GPMC)
- MAIN ドメインの 3x512KB のオンチップ SRAM、ECC 保護付き

#### 機能安全:

- 機能安全準拠製品向け (一部の部品番号でのみ対応)
  - 機能安全アプリケーション向けに開発
  - ISO 26262 機能安全システムの設計に役立つ資料を入手可能、ASIL-D/SIL-3 までを対象
  - 決定論的対応能力、ASIL-D/SIL-3 までを対象
  - ハードウェア整合性、MCU ドメイン向け ASIL-D/SIL-3 までを対象
  - ハードウェア整合性、MAIN ドメイン向け ASIL-B/SIL-2 までを対象
  - ハードウェア整合性、MAIN ドメインの拡張 MCU (EMCU) 部分向け ASIL-D/SIL-3 までを対象
  - 安全関連の認証
    - ISO 26262 を計画中
- 部品番号の末尾が Q1 のバリエーションについては AEC-Q100 認定済み

#### デバイスのセキュリティ (一部の部品番号のみ):

- セキュアなランタイム・サポートによるセキュア・ブート
- お客様がプログラム可能なルート・キー (RSA-4K または ECC-512 まで)
- 組み込みハードウェア・セキュリティ・モジュール
- 暗号化ハードウェア・アクセラレータ – ECC 付き PKA、AES、SHA、RNG、DES、3DES

#### 高速シリアル・インターフェイス:

- 最大 8 つ (TDA4xH) または 4 つ (TDA4xP) の外部ポートをサポートする内蔵のイーサネット・スイッチ
  - 2 つのポートが 5Gb、10Gb USXGMII/XFI をサポート
  - すべてのポートが 1Gb、2.5Gb SGMII をサポート
  - すべてのポートが QSGMII をサポート可能。最大 2 つ (TDA4xH) または 1 つ (TDA4xP) の QSGMII をイネーブルにでき、8 つまたは 4 つの内部レーンをすべて使用
- 最大 4 つの 2-L/2x4L (TDA4xH) または 2x2L/1x4L (TDA4xP) の PCI-Express® (PCIe) Gen3 コントローラ
  - Gen1 (2.5GT/s)、Gen2 (5.0GT/s)、Gen3 (8.0GT/s) で動作 (オート・ネゴシエーション付き)
- 1 つの USB 3.0 デュアルロール・デバイス (DRD) サブシステム
  - Enhanced SuperSpeed Gen1 ポート
  - Type-C スイッチングをサポート
  - USB ホスト、USB ペリフェラル、USB DRD として個別に構成可能
- 3 つの CSI2.0 4L RX と 2 つの CSI2.0 4L TX



**TDA4VH-Q1, TDA4AH-Q1, TDA4VP-Q1, TDA4AP-Q1**

JAJSQ14A – FEBRUARY 2023 – REVISED AUGUST 2023

- 2つの RGMII/RMII インターフェイス
- **車載インターフェイス:**
- CAN-FD をフルサポートする 20 個のモジュラー・コントローラ・エリア・ネットワーク (MCAN) モジュール
- **ディスプレイ・サブシステム:**
- 2つの DSI 4L TX (最大 2.5K)
- 1つの eDP/DP インターフェイス (マルチ・ディスプレイ・サポート (MST) 付き)
- 1つの DPI
- **オーディオ・インターフェイス:**
- 5 個のマルチチャネル・オーディオ・シリアル・ポート (MCASP) モジュール
- **ビデオ・アクセラレーション:**
- H.264/H.265 エンコード / デコード、最大 960MP/s (TDA4xH) または 480MP/s (TDA4xP)

- **フラッシュ・メモリ・インターフェイス:**
- 組み込み MultiMediaCard インターフェイス (eMMC™ 5.1)
- 1つの Secure Digital® 3.0/Secure Digital Input Output 3.0 インターフェイス (SD3.0/SDIO3.0)
- 2つのレーンを持つユニバーサル・フラッシュ・ストレージ (UFS 2.1) インターフェイス
- 2つの独立したフラッシュ・インターフェイスを以下のように構成
  - 1つの OSPI または HyperBus™ または QSPI フラッシュ・インターフェイス、および
  - 1つの QSPI フラッシュ・インターフェイス
- **システム・オン・チップ (SoC) アーキテクチャ:**
- 16nm FinFET テクノロジー
- 31mm × 31mm、0.8mm ピッチ、1414 ピンの FCBGA (ALY)、IPC クラス 3 PCB 配線に対応
- **TPS6594-Q1 コンパニオン・パワー・マネージメント IC (PMIC):**
- ASIL-D までの機能安全対応
- 柔軟なマッピングにより各種の使用事例をサポート

## 2 アプリケーション

- 先進のサラウンド・ビューおよび駐車支援システム
- カメラ、レーダー、LIDAR センサを含む自律的センサ・フュージョン / 認識システム
- 単一センサおよびマルチセンサのフロント・カメラ・システム
- 次世代電子ミラー・システム
- 安全機能付きの産業用モバイル・ロボット (AGV/AMR)
- マシン・ビジョン
- スマート・リテール
- スマート・ショッピング・カート
- 建設、農業
- エッジ AI ボックス
- シングル・ボード・コンピュータ
- オフハイウェイ車両向け制御機能
- AI を搭載した産業用 PC
- ADAS ドメイン・コントローラ

### 3 概要

TDA4VH、TDA4AH、TDA4VP、TDA4AP プロセッサ・ファミリーは、画期的な Jacinto™ 7 アーキテクチャを基礎とし、ADAS および自動運転車 (AV) アプリケーションを対象としており、ADAS プロセッサ市場においてテキサス・インスツルメンツがリーダーとして 10 年以上蓄積した膨大な市場知識の上に構築されています。TDA4VH、TDA4AH、TDA4VP、TDA4AP デバイスは、機能安全準拠の対象アーキテクチャにおける、高性能コンピューティング、ディープ・ラーニング・エンジン、信号処理および画像処理専用のアクセラレータの独自の組み合わせにより、以下のようなさまざまなイメージング、ビジョン、レーダー、センサ・フュージョンおよび AI アプリケーションに最適です。ロボット、移動機械、オフハイウェイ車両コントローラ、マシン・ビジョン、AI ボックス、ゲートウェイ、小売オートメーション、医療用画像処理など。TDA4VH、TDA4AH、TDA4VP、TDA4AP は、高度なシステム統合によって、従来型とディープ・ラーニングの両方のアルゴリズムを業界最高の電力 / 性能比で計算し、集中 ECU またはスタンドアロン・センサの複数センサ方式をサポートする先進車載用プラットフォームの拡張性とコスト低減を実現できます。主要なコアとして、スカラおよびベクタ・コアを持つ次世代 DSP、ディープ・ラーニング専用および従来型アルゴリズム用アクセラレータ、汎用計算用の最新の Arm および GPU プロセッサ、統合型次世代イメージング・サブシステム (ISP)、ビデオ・コーデック、イーサネット・ハブ、分離された MCU アイランドが含まれています。これらはすべて、車載グレードの安全およびセキュリティ・ハードウェア・アクセラレータにより保護されています。

#### 主要な高性能コアの概要

「C7x」次世代 DSP は、テキサス・インスツルメンツの業界最先端の DSP と EVE コアを 1 つの高性能コアに統合し、浮動小数点ベクトル計算機能を追加することで、ソフトウェアのプログラミングを簡単にしながらかの従来コードとの後方互換性を確保しています。新しい「MMA」ディープ・ラーニング・アクセラレータは、一般的な車載用の最も厳しい接合部温度である 125°C で動作する場合でも、業界最小の電力エンベロップ内で最大 8TOPS の性能を達成できます。専用 ADAS/AV ハードウェア・アクセラレータは、システム性能に影響を及ぼさずに、ビジョン前処理と測距およびモーション処理を実行します。

#### 汎用コンピューティング・コアと統合の概要

Arm® Cortex®-A72 の独立 8 コア・クラスタ構成を使うと、ソフトウェア・ハイパーバイザの必要性を最小限に抑えながらマルチ OS アプリケーションを簡単に実現できます。8 つの Arm® Cortex®-R5F サブシステムが低レベルのタイム・クリティカルなタスクを処理し、Arm® Cortex®-A72 のコアに負荷がかからないようにしてアプリケーションの実行に備えます。内蔵の IMG BXS-64-4 GPU は最高 50GFLOPS の性能を備えており、拡張表示アプリケーションの動的 3D レンダリングを可能にします。既存の世界最先端の ISP に基づいて構築されたテキサス・インスツルメンツの第 7 世代 ISP は、より広範なセンサ・スイートを処理する柔軟性、より深いビット深度のサポート、分析アプリケーションを対象とした機能を備えています。内蔵セキュリティ機能が現代の攻撃からデータを保護する一方で、内蔵の診断および安全機能は ASIL-D/SIL-3 レベルまでの動作をサポートしています。大きなデータ帯域幅を要求するシステムに対応するため、PCIe ハブとギガビット・イーサネット・スイッチが内蔵されており、多くのセンサ入力に必要なスループットをサポートするための CSI-2 ポートも内蔵されています。さらに高度な統合のために TDA4VH TDA4AH TDA4VP TDA4AP ファミリーには MCU アイランドも内蔵されているので、外部のシステム・マイコンは不要です。

#### パッケージ情報

部品番号	パッケージ (1)	パッケージ・サイズ (2)
TDA4VH-Q1	ALY (FCBGA, 1414)	31mm × 31mm
TDA4AH-Q1	ALY (FCBGA, 1414)	31mm × 31mm
TDA4VP-Q1	ALY (FCBGA, 1414)	31mm × 31mm
TDA4AP-Q1	ALY (FCBGA, 1414)	31mm × 31mm
XJ784S4GAALY	ALY (FCBGA, 1414)	31mm × 31mm

(1) 詳細については、[セクション 11](#)、「メカニカル、パッケージ、および注文情報」を参照してください。

(2) パッケージ・サイズ (長さ×幅) は公称値であり、該当する場合はピンも含まれます。

### 3.1 機能ブロック図

図 3-1 は、このデバイスの機能ブロック図です。

**注**

テキサス・インスツルメンツのソフトウェア開発キット (SDK) が現在サポートしているデバイス機能の詳細については、[TDA4VH ソフトウェア・ビルド・シート \(PROCESSOR-SDK-J784S4\)](#) を参照してください。



図 3-1. 機能ブロック図

## Table of Contents

1 特長.....	1	7.9 Temperature Sensor Characteristics.....	151
2 アプリケーション.....	2	7.10 Timing and Switching Characteristics.....	152
3 概要.....	3	<b>8 Detailed Description.....</b>	<b>270</b>
3.1 機能ブロック図.....	4	8.1 Overview.....	270
4 Revision History.....	5	8.2 Processor Subsystems.....	271
5 Device Comparison.....	7	8.3 Accelerators and Coprocessors.....	272
6 Terminal Configuration and Functions.....	10	8.4 Other Subsystems.....	273
6.1 Pin Diagrams.....	10	<b>9 Applications, Implementation, and Layout.....</b>	<b>282</b>
6.2 Pin Attributes.....	10	9.1 Device Connection and Layout Fundamentals.....	282
6.3 Signal Descriptions.....	87	9.2 Peripheral- and Interface-Specific Design Information.....	282
6.4 Pin Connectivity Requirements.....	132	<b>10 Device and Documentation Support.....</b>	<b>289</b>
7 Specifications.....	137	10.1 Device Nomenclature.....	289
7.1 Absolute Maximum Ratings.....	137	10.2 Tools and Software.....	292
7.2 ESD Ratings.....	138	10.3 サポート・リソース.....	292
7.3 Power-On-Hour (POH) Limits.....	139	10.4 Trademarks.....	292
7.4 Recommended Operating Conditions.....	139	10.5 静電気放電に関する注意事項.....	292
7.5 Operating Performance Points.....	141	10.6 用語集.....	292
7.6 Electrical Characteristics.....	142	<b>11 Mechanical, Packaging, and Orderable Information.....</b>	<b>293</b>
7.7 VPP Specifications for One-Time Programmable (OTP) eFuses.....	148	11.1 Packaging Information.....	293
7.8 Thermal Resistance Characteristics.....	150		

## 4 Revision History

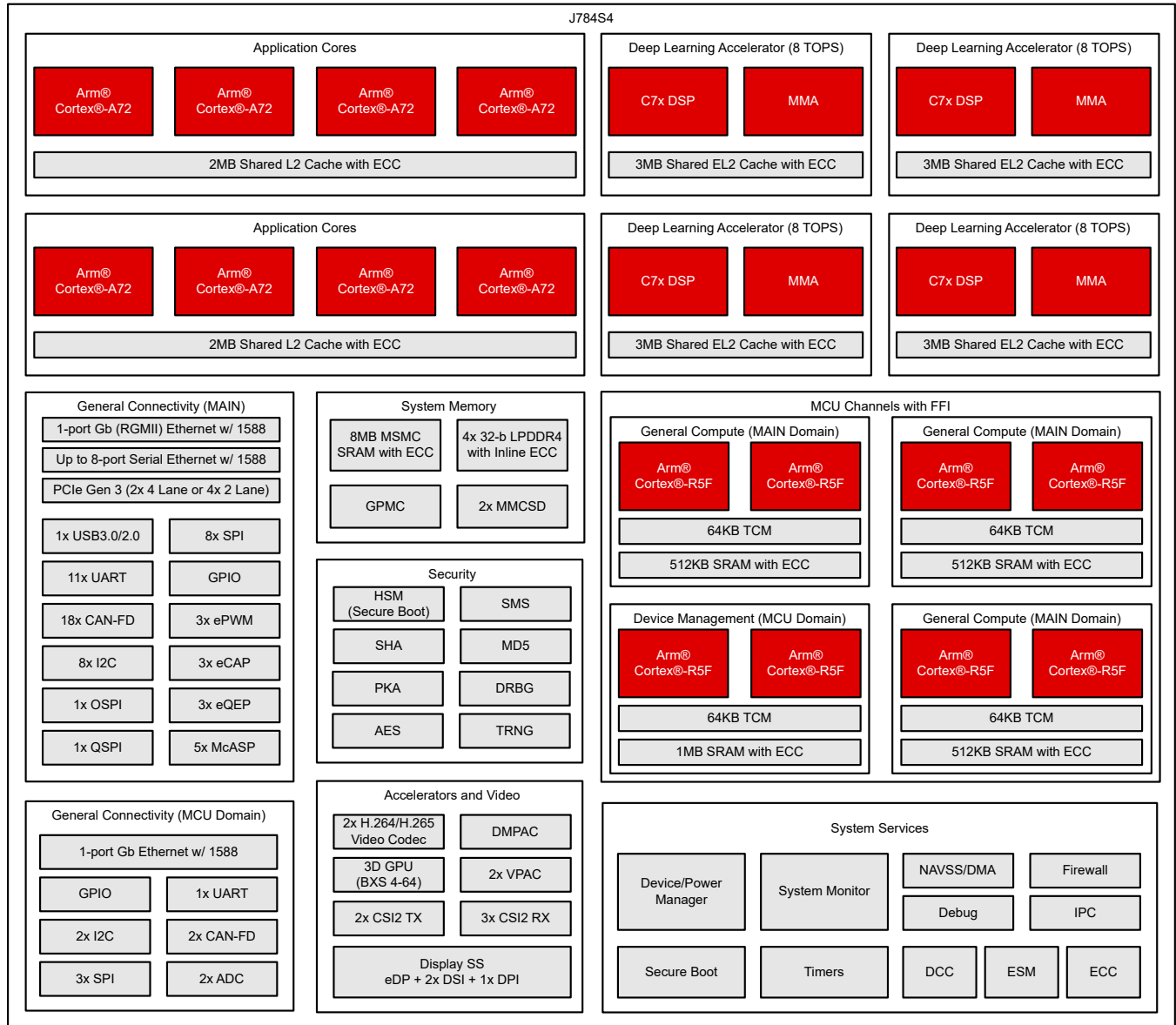
### Changes from February 19, 2023 to August 18, 2023 (from Revision \* (FEBRUARY 2023) to Revision A (AUGUST 2023))

	Page
• グローバル:すべての OLDI/LVDS コンテンツを削除、このデバイス・スイートに該当なし.....	1
• グローバル:3D グラフィックス処理ユニット (GPU) について、「BSX」、「BSX-64-4」、および「BXS-64-4」から「IMG BXS-4-64」に更新 / 変更.....	1
• (パッケージ情報):新しいコンテンツ標準に合わせて表を更新 / 変更.....	3
• (機能ブロック図):スーパーセット・デバイスを示すように画像を更新 / 変更し、新しい画像には適用できないため関連する脚注を削除.....	4
• (機能ブロック図):ソフトウェア・ビルド・シートの注を追加.....	4
• (Device Comparison): Merged table cells to show commonality/differences and to improve readability.....	7
• (Device Comparison): Added software build sheet note.....	7
• (Device Comparison): Changed MSMC size.....	7
• (Device Comparison): Modified restrictions on SERDES muxing for PCIe and SGMII to allow flexible mapping for 4-port SGMII and 1x4L/2x2I PCIe.....	7
• (Device Comparison): Added notes to clarify LPDDR instance usage for a) software compatibility with 27 mm package, and b) requirements for using fewer than 4 DDR instances.....	7
• (Device Comparison): Added notes to clarify that SERDES2 is not available on a 27mm package variant of this SoC.....	7
• (DDRSS0 Signal Descriptions): Added "DDRSS incremental order" footnote.....	88
• (DDRSS1 Signal Descriptions): Added "DDRSS incremental order" footnote.....	89
• (DDRSS2 Signal Descriptions): Added "DDRSS incremental order" footnote.....	91
• (DDRSS2 Signal Descriptions): Added DDRSS2, DDRSS3, and SERDES2 availability footnote.....	91
• (DDRSS3 Signal Descriptions): Added "DDRSS incremental order" footnote.....	92
• (DDRSS3 Signal Descriptions): Added DDRSS2, DDRSS3, and SERDES2 availability footnote.....	92
• (SERDES2 Signal Descriptions): Added DDRSS2, DDRSS3, and SERDES2 availability footnote.....	114
• (Pin Connectivity Requirements) Updated ADC AIN recommendation to allow the tie-off of signals directly to ground.....	132
• (Pin Connectivity Requirements): Added requirement for DDR interfaces to be used in incrementing order.....	132

- 
- (Recommended Operating Conditions): Added clarification to the "... supply inputs" footnote, specifically for VDD\_CORE, VDD\_MCU, and VDD\_CPU domains plus, added cross-references to the MIN/MAX values.. [139](#)
  - (Recommended Operating Conditions): Added vdda\_\* noise specification..... [139](#)
  - (USB VBUS Design Guidelines): Updated/Changed USB VBUS Detect Voltage Divider / Clamp Circuit figure.....[285](#)
-

## 5 Device Comparison

表 5-1 shows the features of the SoC.

注

To understand what device features are currently supported by TI Software Development Kits (SDKs), see the [TDA4VH Software Build Sheet \(PROCESSOR-SDK-J784S4\)](#).

**表 5-1. Device Comparison**

FEATURES <sup>(9)</sup>	REFERENCE NAME	TDA4VH88	TDA4AH88	TDA4VP88	TDA4AP88
<b>FEATURES</b>					
<b>PROCESSORS AND ACCELERATORS</b>					
Speed Grades		T	T	T	T
Arm Cortex-A72 Microprocessor Subsystem	Arm A72	Octal Core			
Arm Cortex-R5F	Arm R5F	Octal Core			
	Lockstep	Optional <sup>(1)</sup>			
Security Management	SMS	Yes			
Security Accelerators	SA	Yes			
C7x Floating Point, Vector DSP	C7x DSP	Quad Core		Tri Core	
Deep Learning Accelerator	MMA	Quad Core		Tri Core	
Graphics Accelerator IMG BXS-4-64	GPU	Yes	No	Yes	No
Depth and Motion Processing Accelerators	DMPAC	Yes			
Vision Processing Accelerators	VPAC	2			
Video Encoder / Decoder	VENC/ VDEC	Enc/Dec 960 MP/s		Enc/Dec 480 MP/s	
<b>SAFETY AND SECURITY</b>					
Safety Targeted	Safety	Optional <sup>(1)</sup>			
Device Security	Security	Optional <sup>(2)</sup>			
AEC-Q100 Qualified	Q1	Optional <sup>(3)</sup>			
<b>PROGRAM AND DATA STORAGE</b>					
On-Chip Shared Memory (RAM) in MAIN Domain	OCSRAM	3x512KB SRAM			
On-Chip Shared Memory (RAM) in MCU Domain	MCU_MSRRAM	1MB SRAM			
Multicore Shared Memory Controller	MSMC	8MB (On-Chip SRAM with ECC)			
LPDDR4 DDR Subsystem	DDRSS0 <sup>(5)</sup>	32-b w/ inline ECC			
	DDRSS1 <sup>(5)</sup>	32-b w/ inline ECC			
	DDRSS2 <sup>(4) (5)</sup>	32-b w/ inline ECC			
	DDRSS3 <sup>(4) (5)</sup>	32-b w/ inline ECC		No	
	SECCDED	7-Bit			
General-Purpose Memory Controller	GPMC	Yes			
<b>PERIPHERALS <sup>(12)</sup></b>					
Display Subsystem	DSS	Yes			
	DSI 4L TX	2			
	eDP 4L	1			
	DPI	1			
Modular Controller Area Network Interface with Full CAN-FD Support	MCAN	20			
General-Purpose I/O	GPIO	155			

表 5-1. Device Comparison (continued)

FEATURES <sup>(9)</sup>	REFERENCE NAME	TDA4VH88	TDA4AH88	TDA4VP88	TDA4AP88
Inter-Integrated Circuit Interface	I2C			10	
Improved Inter-Integrated Circuit Interface	I3C			1	
Analog-to-Digital Converter	ADC			2	
Capture Subsystem with Camera Serial Interface (CSI2)	CSI2.0 4L RX			3	
	CSI2.0 4L TX			2	
Multichannel Serial Peripheral Interface	MCSPi			11	
Multichannel Audio Serial Port	MCASP0			16 Serializers	
	MCASP1			5 Serializers	
	MCASP2			5 Serializers	
	MCASP3			3 Serializers	
	MCASP4			5 Serializers	
MultiMedia Card/ Secure Digital Interface	MMCSD0			eMMC (8-bits)	
	MMCSD1			SD/SDIO (4-bits)	
Universal Flash Storage	UFS 2L			Yes	
Flash Subsystem (FSS)	OSPI0			8-bits <sup>(8)</sup>	
	OSPI1 <sup>(10)</sup>			4-bits	
	HyperBus			Yes <sup>(8)</sup>	
4x PCI Express Port with Integrated PHY	PCIE	2x4L or 4x2L <sup>(6)</sup>		1x4L or 2x2L <sup>(6) (11)</sup>	
Ethernet Interfaces	MCU CPSW2G			RMII or RGMII	
	MAIN CPSW2G			RMII or RGMII	
	CPSW9G	8 port SERDES <sup>(6)</sup>		4 port SERDES <sup>(6) (7)</sup>	
General-Purpose Timers	TIMER			30	
Enhanced High Resolution Pulse-Width Modulator Module	eHRPWM			6	
Enhanced Capture Module	eCAP			3	
Enhanced Quadrature Encoder Pulse Module	eQEP			3	
Universal Asynchronous Receiver and Transmitter	UART			12	
Universal Serial Bus (USB3.1) SuperSpeed Dual-Role-Device (DRD) Ports with SS PHY	USB0			Yes <sup>(6)</sup>	

ADVANCE INFORMATION

- (1) Safety features including R5F Lockstep and SIL/ASIL ratings are only applicable to select part number variants as indicated by the Device Type (Y) identifier in the [Nomenclature Description](#) table.
- (2) Device security features including Secure Boot and Customer Programmable Keys are applicable to select part number variants as indicated by the Device Type (Y) identifier in the [Nomenclature Description](#) table.
- (3) AEC-Q100 qualification is applicable to select part number variants as indicated by the Automotive Designator (Q1) identifier in the [Nomenclature Description](#) table.
- (4) DDRSS2 and DDRSS3 are not available on the 27mm package variant of this SoC. DDR2/DDR3 should be not be used if software compatibility is desired with systems that use the 27mm package
- (5) DDRSS0, DDRSS1, DDRSS2 and DDRSS3 must always be used in incremental order. For instance, when using a single LPDDR component, it must be connected to DDR0\_\* interface. When using two LPDDR components, they must be connected to DDR0\_\* and DDR1\_\* interfaces, and so forth.
- (6) DP, SGMII, USB3.0, and PCIE share total of 16 SerDes lanes. **SERDES2** is not available on the 27mm package variant of this SoC. SERDES2 should not be used if software compatibility is desired with systems that use the 27mm package.
- (7) **TDA4xH** CPSW supports up to 8 ports using the following instances and signals and modes of operation:
  - PORT1 **Signals:** SGMII1, **Modes:** One of 5Gb, 10Gb USXGMII/XFI, 2.5 Gb SGMII/XAUI, 1Gb SGMII, 5Gb QSGMII
  - PORT2 **Signals:** SGMII2, **Modes:** One of 5Gb, 10Gb USXGMII/XFI, 2.5 Gb SGMII/XAUI, 1Gb SGMII, 5Gb QSGMII
  - PORTn (n=3 thru 8) **Signals:** SGMII<sub>n</sub>, **Modes:** One of 2.5 Gb SGMII/XAUI, 1Gb SGMII, 5Gb QSGMII



If QSGMII is used on any SGMII Port 1 thru 4, then SGMII1/2/3/4 cannot be used for Ethernet functionality since all 4 internal CPSW ports map to the selected QSGMII SERDES port.

If QSGMII is used on any SGMII Port 5 thru 8, then SGMII5/6/7/8 cannot be used for Ethernet functionality since all 4 internal CPSW ports map to the selected QSGMII SERDES port.

**TDA4xP** CPSW supports up to 4 ports. To maximize pin muxing flexibility, the system designer can choose based on any available PORTS, but must limit the total number of ports used to four or fewer.

- (8) Two simultaneous flash interfaces configured as OSPI0 and OSPI1, or HyperBus and OSPI1.
- (9) XJ784S4 is the base part number for the superset device. Software should constrain the features used to match the intended production device.
- (10) OSPI1 module only pins out 4 pins and is referred to as QSPI in some contexts.
- (11) **TDA4xP** PCIe supports 1x4L or 2x2L options. To maximize pin muxing flexibility, the system designer can choose any available PCIe instances or available PORTS, but must limit to a maximum of 1x4L or 2x2L.
- (12) Hyperlink is not supported on this SoC. System designs should not use the signals HYP\_\*, HYP0\_\*, HYP1\_\*.

## 6 Terminal Configuration and Functions

### 6.1 Pin Diagrams

注

The terms "ball", "pin", and "terminal" are used interchangeably throughout the document. An attempt is made to use "ball" only when referring to the physical package.

For details on the pin diagram, see the [Mechanical, Packaging, and Orderable Information](#) section.

### 6.2 Pin Attributes

1. **Ball Number:** Ball numbers assigned to each terminal of the Ball Grid Array package.
2. **Ball Name:** Ball name assigned to each terminal of the Ball Grid Array package (this name is typically taken from the primary MUXMODE 0 signal function).
3. **Signal Name:** Signal name of all dedicated and pin multiplexed signal functions associated with a ball.

注

The *Pin Attributes* table, defines the SoC pin multiplexed signal function implemented at the pin and **does not** define secondary multiplexing of signal functions implemented in device subsystems. Secondary multiplexing of signal functions are not described in this table. For more information on secondary multiplexed signal functions, see the respective peripheral chapter of the device TRM.

4. **Mux Mode:** The MUXMODE value associated with each pin multiplexed signal function:
  - MUXMODE 0 is the primary pin multiplexed signal function. However, the primary pin multiplexed signal function is not necessarily the default pin multiplexed signal function.
  - MUXMODE values 1 through 15 are possible for pin multiplexed signal functions. However, not all MUXMODE values have been implemented. The only valid MUXMODE values are those defined as pin multiplexed signal functions within the Pin Attributes table. Only valid values of MUXMODE can be used.
  - Bootstrap defines SOC configuration pins, where the logic state applied to each pin is latched on the rising edge of PORz\_OUT. These input signal functions are fixed to their respective pins and are not programmable via MUXMODE.
  - An empty box or "-" means Not Applicable.

注

- The value found in the MUX MODE AFTER RESET column defines the default pin multiplexed signal function selected when MCU\_PORz is deasserted.
- Configuring two pins to the same pin multiplexed signal function can yield unexpected results and is not supported. This can be prevented with proper software configuration.
- Configuring a pad to an undefined multiplexing mode results in undefined behavior and must be avoided.

5. **Signal Type:** Signal type and direction:
  - I = Input
  - O = Output
  - OD = Output, with open-drain output function
  - IO = Input, Output, or simultaneously Input and Output
  - IOD = Input, Output, or simultaneously Input and Output, with open-drain output function
  - IOZ = Input, Output, or simultaneously Input and Output, with three-state output function
  - OZ = Output with three-state output function
  - A = Analog
  - CAP = LDO capacitor
  - PWR = Power
  - GND = Ground

6. **I/O VOLTAGE VALUE:** This column describes the IO voltage value (the corresponding power supply). An empty box means Not Applicable.
7. **Ball State During Reset (RX/TX/PULL):** State of the terminal while MCU\_PORz is asserted, where RX defines the state of the input buffer, TX defines the state of the output buffer, and PULL defines the state of internal pull resistors:
  - RX (Input buffer)
    - Off: The input buffer is **disabled**.
    - On: The input buffer is **enabled**.
  - TX (Output buffer)
    - Off: The output buffer is **disabled**.
    - Low: The output buffer is **enabled** and drives  $V_{OL}$ .
  - PULL (Internal pull resistors)
    - Off: Internal pull resistors are turned **off**.
    - Up: Internal **pull-up** resistor is turned on.
    - Down: Internal **pull-down** resistor is turned on.
    - NA: No internal pull resistor.
  - An empty box, or "-" means Not Applicable.
8. **Ball State After Reset (RX/TX/PULL):** State of the terminal after MCU\_PORz is deasserted, where RX defines the state of the input buffer, TX defines the state of the output buffer, and PULL defines the state of internal pull resistors:
  - RX (Input buffer)
    - Off: The input buffer is **disabled**.
    - On: The input buffer is **enabled**.
  - TX (Output buffer)
    - Off: The output buffer is **disabled**.
    - SS: The subsystem selected with MUXMODE determines the output buffer state.
  - PULL (Internal pull resistors)
    - Off: Internal pull resistors are turned **off**.
    - Up: Internal **pull-up resistor** is turned on.
    - Down: Internal **pull-down resistor** is turned on.
    - NA: No internal pull resistor.
  - An empty box, NA, or "-" means Not Applicable.
9. **Mux Mode After Reset:** The value found in this column defines the **default** pin multiplexed signal function after MCU\_PORz is deasserted.
  - An empty box, NA, or "-" means Not Applicable.
10. **PULL TYPE:** Indicates the presence of an internal pullup or pulldown resistor. Pullup and pulldown resistors can be enabled or disabled via software.
  - PU: Internal pull-up Only
  - PD: Internal pull-down Only
  - PU/PD: Internal pull-up and pull-down
  - An empty box, NA, or "-" means No internal pull.

注

Configuring two pins to the same pin multiplexed signal function is not supported as this yields unexpected results. Issues can be easily prevented with the proper software configuration.

When a pad is set into a multiplexing mode which is not defined by pin multiplexing, that pad's behavior is undefined. This must be avoided.

11. **Power:** The power supply of the associated I/O, when applicable.
  - An empty box, NA, or "-" means Not Applicable.

12. **Hys:** Indicates if the input buffer associated with this I/O has hysteresis:

- Yes: Hysteresis Support
- No: **No** Hysteresis Support
- An empty box, NA, or "-" means Not Applicable.

For more information, see the hysteresis values in [Electrical Characteristics](#) section.

13. **Voltage Buffer Type:** This column defines the buffer type associated with a terminal. This information can be used to determine the applicable Electrical Characteristics table.

- An empty box, NA, or "-" means Not Applicable.

For electrical characteristics, refer to the appropriate buffer type table in [Electrical Characteristics](#) section.

14. **IO RET:** Yes means WKUP and IO retention supported.

15. **Pad Configuration Register Name:** This is the name of the device pad/pin configuration register.

16. **Pad Configuration Register Address:** This is the memory address of the device pad/pin configuration register.

**表 6-1. Pin Attributes (ALY Package)**

Ball Num [1]	Ball Name [2] PADCFG Register [15] PADCFG Address [16]	Signal Name [3]	Mux Mode [4]	Signal Type [5]	I/O Voltage [6]	Ball State DURING Reset (RX/TX/PULL) [7]	Ball State AFTER Reset (RX/TX/PULL) [8]	Mux Mode AFTER Reset [9]	Pull Type [10]	Power [11]	Hys [12]	Voltage Buffer Type [13]	IO RET [14]
V29	CAP_VDDSD0	CAP_VDDSD0		CAP									
L27	CAP_VDDSD0_MCU	CAP_VDDSD0_MCU		CAP									
L25	CAP_VDDSD1_MCU	CAP_VDDSD1_MCU		CAP									
T29	CAP_VDDSD2	CAP_VDDSD2		CAP									
L26	CAP_VDDSD2_MCU	CAP_VDDSD2_MCU		CAP									
P29	CAP_VDDSD5	CAP_VDDSD5		CAP									
AN30	CSI0_RXCLKN	CSI0_RXCLKN		I	1.8 V					VDDA_0P8_C SIRX0_1 / VDDA_1P8_C SIRX0_1		D-PHY	
AN29	CSI0_RXCLKP	CSI0_RXCLKP		I	1.8 V					VDDA_0P8_C SIRX0_1 / VDDA_1P8_C SIRX0_1		D-PHY	
AM28	CSI0_RXRCALIB	CSI0_RXRCALIB		A	1.8 V					VDDA_0P8_C SIRX0_1 / VDDA_1P8_C SIRX0_1		D-PHY	
AP32	CSI1_RXCLKN	CSI1_RXCLKN		I	1.8 V					VDDA_0P8_C SIRX0_1 / VDDA_1P8_C SIRX0_1		D-PHY	
AP31	CSI1_RXCLKP	CSI1_RXCLKP		I	1.8 V					VDDA_0P8_C SIRX0_1 / VDDA_1P8_C SIRX0_1		D-PHY	
AL28	CSI1_RXRCALIB	CSI1_RXRCALIB		A	1.8 V					VDDA_0P8_C SIRX0_1 / VDDA_1P8_C SIRX0_1		D-PHY	
AN32	CSI2_RXCLKN	CSI2_RXCLKN		I	1.8 V					VDDA_0P8_C SIRX2 / VDDA_1P8_C SIRX2		D-PHY	
AN33	CSI2_RXCLKP	CSI2_RXCLKP		I	1.8 V					VDDA_0P8_C SIRX2 / VDDA_1P8_C SIRX2		D-PHY	
AM31	CSI2_RXRCALIB	CSI2_RXRCALIB		A	1.8 V					VDDA_0P8_C SIRX2 / VDDA_1P8_C SIRX2		D-PHY	
AU33	CSI0_RXN0	CSI0_RXN0		I	1.8 V					VDDA_0P8_C SIRX0_1 / VDDA_1P8_C SIRX0_1		D-PHY	

ADVANCE INFORMATION

表 6-1. Pin Attributes (ALY Package) (continued)

Ball Num [1]	Ball Name [2] PADCFG Register [15] PADCFG Address [16]	Signal Name [3]	Mux Mode [4]	Signal Type [5]	I/O Voltage [6]	Ball State DURING Reset (RX/TX/PULL) [7]	Ball State AFTER Reset (RX/TX/PULL) [8]	Mux Mode AFTER Reset [9]	Pull Type [10]	Power [11]	Hys [12]	Voltage Buffer Type [13]	IO RET [14]
AT32	CSI0_RXN1	CSI0_RXN1		I	1.8 V					VDDA_0P8_C SIRX0_1 / VDDA_1P8_C SIRX0_1		D-PHY	
AV31	CSI0_RXN2	CSI0_RXN2		I	1.8 V					VDDA_0P8_C SIRX0_1 / VDDA_1P8_C SIRX0_1		D-PHY	
AR30	CSI0_RXN3	CSI0_RXN3		I	1.8 V					VDDA_0P8_C SIRX0_1 / VDDA_1P8_C SIRX0_1		D-PHY	
AU32	CSI0_RXP0	CSI0_RXP0		I	1.8 V					VDDA_0P8_C SIRX0_1 / VDDA_1P8_C SIRX0_1		D-PHY	
AT31	CSI0_RXP1	CSI0_RXP1		I	1.8 V					VDDA_0P8_C SIRX0_1 / VDDA_1P8_C SIRX0_1		D-PHY	
AV30	CSI0_RXP2	CSI0_RXP2		I	1.8 V					VDDA_0P8_C SIRX0_1 / VDDA_1P8_C SIRX0_1		D-PHY	
AR29	CSI0_RXP3	CSI0_RXP3		I	1.8 V					VDDA_0P8_C SIRX0_1 / VDDA_1P8_C SIRX0_1		D-PHY	
AT35	CSI1_RXN0	CSI1_RXN0		I	1.8 V					VDDA_0P8_C SIRX0_1 / VDDA_1P8_C SIRX0_1		D-PHY	
AU36	CSI1_RXN1	CSI1_RXN1		I	1.8 V					VDDA_0P8_C SIRX0_1 / VDDA_1P8_C SIRX0_1		D-PHY	
AR33	CSI1_RXN2	CSI1_RXN2		I	1.8 V					VDDA_0P8_C SIRX0_1 / VDDA_1P8_C SIRX0_1		D-PHY	
AV34	CSI1_RXN3	CSI1_RXN3		I	1.8 V					VDDA_0P8_C SIRX0_1 / VDDA_1P8_C SIRX0_1		D-PHY	
AT34	CSI1_RXP0	CSI1_RXP0		I	1.8 V					VDDA_0P8_C SIRX0_1 / VDDA_1P8_C SIRX0_1		D-PHY	

ADVANCE INFORMATION

**表 6-1. Pin Attributes (ALY Package) (continued)**

Ball Num [1]	Ball Name [2] PADCFG Register [15] PADCFG Address [16]	Signal Name [3]	Mux Mode [4]	Signal Type [5]	I/O Voltage [6]	Ball State DURING Reset (RX/TX/PULL) [7]	Ball State AFTER Reset (RX/TX/PULL) [8]	Mux Mode AFTER Reset [9]	Pull Type [10]	Power [11]	Hys [12]	Voltage Buffer Type [13]	IO RET [14]
AU35	CSI1_RXP1	CSI1_RXP1		I	1.8 V					VDDA_0P8_C SIRX0_1 / VDDA_1P8_C SIRX0_1		D-PHY	
AR32	CSI1_RXP2	CSI1_RXP2		I	1.8 V					VDDA_0P8_C SIRX0_1 / VDDA_1P8_C SIRX0_1		D-PHY	
AV33	CSI1_RXP3	CSI1_RXP3		I	1.8 V					VDDA_0P8_C SIRX0_1 / VDDA_1P8_C SIRX0_1		D-PHY	
AR36	CSI2_RXN0	CSI2_RXN0		I	1.8 V					VDDA_0P8_C SIRX2 / VDDA_1P8_C SIRX2		D-PHY	
AT38	CSI2_RXN1	CSI2_RXN1		I	1.8 V					VDDA_0P8_C SIRX2 / VDDA_1P8_C SIRX2		D-PHY	
AP35	CSI2_RXN2	CSI2_RXN2		I	1.8 V					VDDA_0P8_C SIRX2 / VDDA_1P8_C SIRX2		D-PHY	
AV37	CSI2_RXN3	CSI2_RXN3		I	1.8 V					VDDA_0P8_C SIRX2 / VDDA_1P8_C SIRX2		D-PHY	
AR35	CSI2_RXP0	CSI2_RXP0		I	1.8 V					VDDA_0P8_C SIRX2 / VDDA_1P8_C SIRX2		D-PHY	
AT37	CSI2_RXP1	CSI2_RXP1		I	1.8 V					VDDA_0P8_C SIRX2 / VDDA_1P8_C SIRX2		D-PHY	
AP34	CSI2_RXP2	CSI2_RXP2		I	1.8 V					VDDA_0P8_C SIRX2 / VDDA_1P8_C SIRX2		D-PHY	
AV36	CSI2_RXP3	CSI2_RXP3		I	1.8 V					VDDA_0P8_C SIRX2 / VDDA_1P8_C SIRX2		D-PHY	
AB2	DDR0_CKN	DDR0_CKN		IO	1.1 V					VDDS_DDR / VDDS_DDR_ C0		DDR	
AC1	DDR0_CKP	DDR0_CKP		IO	1.1 V					VDDS_DDR / VDDS_DDR_ C0		DDR	

表 6-1. Pin Attributes (ALY Package) (continued)

Ball Num [1]	Ball Name [2] PADCFG Register [15] PADCFG Address [16]	Signal Name [3]	Mux Mode [4]	Signal Type [5]	I/O Voltage [6]	Ball State DURING Reset (RX/TX/PULL) [7]	Ball State AFTER Reset (RX/TX/PULL) [8]	Mux Mode AFTER Reset [9]	Pull Type [10]	Power [11]	Hys [12]	Voltage Buffer Type [13]	IO RET [14]
AD5	DDR0_RESETh	DDR0_RESETh		IO	1.1 V					VDDS_DDR / VDDS_DDR_C0		DDR	
AC8	DDR0_RET	DDR0_RET		I	1.1 V					VDDS_DDR / VDDS_DDR_C0		DDR	
A11	DDR1_CKN	DDR1_CKN		IO	1.1 V					VDDS_DDR / VDDS_DDR_C1		DDR	
B10	DDR1_CKP	DDR1_CKP		IO	1.1 V					VDDS_DDR / VDDS_DDR_C1		DDR	
G10	DDR1_RESETh	DDR1_RESETh		IO	1.1 V					VDDS_DDR / VDDS_DDR_C1		DDR	
G8	DDR1_RET	DDR1_RET		I	1.1 V					VDDS_DDR / VDDS_DDR_C1		DDR	
K1	DDR2_CKN	DDR2_CKN		IO	1.1 V					VDDS_DDR / VDDS_DDR_C2		DDR	
L2	DDR2_CKP	DDR2_CKP		IO	1.1 V					VDDS_DDR / VDDS_DDR_C2		DDR	
J5	DDR2_RESETh	DDR2_RESETh		IO	1.1 V					VDDS_DDR / VDDS_DDR_C2		DDR	
L8	DDR2_RET	DDR2_RET		I	1.1 V					VDDS_DDR / VDDS_DDR_C2		DDR	
B25	DDR3_CKN	DDR3_CKN		IO	1.1 V					VDDS_DDR / VDDS_DDR_C3		DDR	
A24	DDR3_CKP	DDR3_CKP		IO	1.1 V					VDDS_DDR / VDDS_DDR_C3		DDR	
C23	DDR3_RESETh	DDR3_RESETh		IO	1.1 V					VDDS_DDR / VDDS_DDR_C3		DDR	
G27	DDR3_RET	DDR3_RET		I	1.1 V					VDDS_DDR / VDDS_DDR_C3		DDR	
AD2	DDR0_CA0	DDR0_CA0		IO	1.1 V					VDDS_DDR / VDDS_DDR_C0		DDR	
AC5	DDR0_CA1	DDR0_CA1		IO	1.1 V					VDDS_DDR / VDDS_DDR_C0		DDR	

ADVANCE INFORMATION



**表 6-1. Pin Attributes (ALY Package) (continued)**

Ball Num [1]	Ball Name [2] PADCFG Register [15] PADCFG Address [16]	Signal Name [3]	Mux Mode [4]	Signal Type [5]	I/O Voltage [6]	Ball State DURING Reset (RX/TX/PULL) [7]	Ball State AFTER Reset (RX/TX/PULL) [8]	Mux Mode AFTER Reset [9]	Pull Type [10]	Power [11]	Hys [12]	Voltage Buffer Type [13]	IO RET [14]
AB4	DDR0_CA2	DDR0_CA2		IO	1.1 V					VDDS_DDR / VDDS_DDR_C0		DDR	
AC4	DDR0_CA3	DDR0_CA3		IO	1.1 V					VDDS_DDR / VDDS_DDR_C0		DDR	
AB3	DDR0_CA4	DDR0_CA4		IO	1.1 V					VDDS_DDR / VDDS_DDR_C0		DDR	
AC3	DDR0_CA5	DDR0_CA5		IO	1.1 V					VDDS_DDR / VDDS_DDR_C0		DDR	
AE8	DDR0_CAL0	DDR0_CAL0		A	1.1 V					VDDS_DDR / VDDS_DDR_C0		DDR	
AB6	DDR0_CKE0	DDR0_CKE0		IO	1.1 V					VDDS_DDR / VDDS_DDR_C0		DDR	
AD3	DDR0_CKE1	DDR0_CKE1		IO	1.1 V					VDDS_DDR / VDDS_DDR_C0		DDR	
AD7	DDR0_CSn0_0	DDR0_CSn0_0		IO	1.1 V					VDDS_DDR / VDDS_DDR_C0		DDR	
AC7	DDR0_CSn0_1	DDR0_CSn0_1		IO	1.1 V					VDDS_DDR / VDDS_DDR_C0		DDR	
AB7	DDR0_CSn1_0	DDR0_CSn1_0		IO	1.1 V					VDDS_DDR / VDDS_DDR_C0		DDR	
AD6	DDR0_CSn1_1	DDR0_CSn1_1		IO	1.1 V					VDDS_DDR / VDDS_DDR_C0		DDR	
V3	DDR0_DM0	DDR0_DM0		IO	1.1 V					VDDS_DDR / VDDS_DDR_C0		DDR	
AA4	DDR0_DM1	DDR0_DM1		IO	1.1 V					VDDS_DDR / VDDS_DDR_C0		DDR	
AG2	DDR0_DM2	DDR0_DM2		IO	1.1 V					VDDS_DDR / VDDS_DDR_C0		DDR	
AJ5	DDR0_DM3	DDR0_DM3		IO	1.1 V					VDDS_DDR / VDDS_DDR_C0		DDR	
U2	DDR0_DQ0	DDR0_DQ0		IO	1.1 V					VDDS_DDR / VDDS_DDR_C0		DDR	

表 6-1. Pin Attributes (ALY Package) (continued)

Ball Num [1]	Ball Name [2] PADCFG Register [15] PADCFG Address [16]	Signal Name [3]	Mux Mode [4]	Signal Type [5]	I/O Voltage [6]	Ball State DURING Reset (RX/TX/PULL) [7]	Ball State AFTER Reset (RX/TX/PULL) [8]	Mux Mode AFTER Reset [9]	Pull Type [10]	Power [11]	Hys [12]	Voltage Buffer Type [13]	IO RET [14]
U4	DDR0_DQ1	DDR0_DQ1		IO	1.1 V					VDDS_DDR / VDDS_DDR_C0		DDR	
W6	DDR0_DQ2	DDR0_DQ2		IO	1.1 V					VDDS_DDR / VDDS_DDR_C0		DDR	
W5	DDR0_DQ3	DDR0_DQ3		IO	1.1 V					VDDS_DDR / VDDS_DDR_C0		DDR	
V4	DDR0_DQ4	DDR0_DQ4		IO	1.1 V					VDDS_DDR / VDDS_DDR_C0		DDR	
V7	DDR0_DQ5	DDR0_DQ5		IO	1.1 V					VDDS_DDR / VDDS_DDR_C0		DDR	
U5	DDR0_DQ6	DDR0_DQ6		IO	1.1 V					VDDS_DDR / VDDS_DDR_C0		DDR	
V6	DDR0_DQ7	DDR0_DQ7		IO	1.1 V					VDDS_DDR / VDDS_DDR_C0		DDR	
Y2	DDR0_DQ8	DDR0_DQ8		IO	1.1 V					VDDS_DDR / VDDS_DDR_C0		DDR	
W3	DDR0_DQ9	DDR0_DQ9		IO	1.1 V					VDDS_DDR / VDDS_DDR_C0		DDR	
AA3	DDR0_DQ10	DDR0_DQ10		IO	1.1 V					VDDS_DDR / VDDS_DDR_C0		DDR	
W2	DDR0_DQ11	DDR0_DQ11		IO	1.1 V					VDDS_DDR / VDDS_DDR_C0		DDR	
AA6	DDR0_DQ12	DDR0_DQ12		IO	1.1 V					VDDS_DDR / VDDS_DDR_C0		DDR	
Y4	DDR0_DQ13	DDR0_DQ13		IO	1.1 V					VDDS_DDR / VDDS_DDR_C0		DDR	
Y5	DDR0_DQ14	DDR0_DQ14		IO	1.1 V					VDDS_DDR / VDDS_DDR_C0		DDR	
AA7	DDR0_DQ15	DDR0_DQ15		IO	1.1 V					VDDS_DDR / VDDS_DDR_C0		DDR	
AF2	DDR0_DQ16	DDR0_DQ16		IO	1.1 V					VDDS_DDR / VDDS_DDR_C0		DDR	

ADVANCE INFORMATION

**表 6-1. Pin Attributes (ALY Package) (continued)**

Ball Num [1]	Ball Name [2] PADCFG Register [15] PADCFG Address [16]	Signal Name [3]	Mux Mode [4]	Signal Type [5]	I/O Voltage [6]	Ball State DURING Reset (RX/TX/PULL) [7]	Ball State AFTER Reset (RX/TX/PULL) [8]	Mux Mode AFTER Reset [9]	Pull Type [10]	Power [11]	Hys [12]	Voltage Buffer Type [13]	IO RET [14]
AE7	DDR0_DQ17	DDR0_DQ17		IO	1.1 V					VDDS_DDR / VDDS_DDR_C0		DDR	
AG3	DDR0_DQ18	DDR0_DQ18		IO	1.1 V					VDDS_DDR / VDDS_DDR_C0		DDR	
AF5	DDR0_DQ19	DDR0_DQ19		IO	1.1 V					VDDS_DDR / VDDS_DDR_C0		DDR	
AE6	DDR0_DQ20	DDR0_DQ20		IO	1.1 V					VDDS_DDR / VDDS_DDR_C0		DDR	
AF4	DDR0_DQ21	DDR0_DQ21		IO	1.1 V					VDDS_DDR / VDDS_DDR_C0		DDR	
AE3	DDR0_DQ22	DDR0_DQ22		IO	1.1 V					VDDS_DDR / VDDS_DDR_C0		DDR	
AE4	DDR0_DQ23	DDR0_DQ23		IO	1.1 V					VDDS_DDR / VDDS_DDR_C0		DDR	
AG5	DDR0_DQ24	DDR0_DQ24		IO	1.1 V					VDDS_DDR / VDDS_DDR_C0		DDR	
AH3	DDR0_DQ25	DDR0_DQ25		IO	1.1 V					VDDS_DDR / VDDS_DDR_C0		DDR	
AJ2	DDR0_DQ26	DDR0_DQ26		IO	1.1 V					VDDS_DDR / VDDS_DDR_C0		DDR	
AH4	DDR0_DQ27	DDR0_DQ27		IO	1.1 V					VDDS_DDR / VDDS_DDR_C0		DDR	
AJ4	DDR0_DQ28	DDR0_DQ28		IO	1.1 V					VDDS_DDR / VDDS_DDR_C0		DDR	
AH6	DDR0_DQ29	DDR0_DQ29		IO	1.1 V					VDDS_DDR / VDDS_DDR_C0		DDR	
AH7	DDR0_DQ30	DDR0_DQ30		IO	1.1 V					VDDS_DDR / VDDS_DDR_C0		DDR	
AG6	DDR0_DQ31	DDR0_DQ31		IO	1.1 V					VDDS_DDR / VDDS_DDR_C0		DDR	
V1	DDR0_DQS0N	DDR0_DQS0N		IO	1.1 V					VDDS_DDR / VDDS_DDR_C0		DDR	

表 6-1. Pin Attributes (ALY Package) (continued)

Ball Num [1]	Ball Name [2] PADCFG Register [15] PADCFG Address [16]	Signal Name [3]	Mux Mode [4]	Signal Type [5]	I/O Voltage [6]	Ball State DURING Reset (RX/TX/PULL) [7]	Ball State AFTER Reset (RX/TX/PULL) [8]	Mux Mode AFTER Reset [9]	Pull Type [10]	Power [11]	Hys [12]	Voltage Buffer Type [13]	IO RET [14]
U1	DDR0_QQS0P	DDR0_QQS0P		IO	1.1 V					VDDS_DDR / VDDS_DDR_C0		DDR	
Y1	DDR0_QQS1N	DDR0_QQS1N		IO	1.1 V					VDDS_DDR / VDDS_DDR_C0		DDR	
AA1	DDR0_QQS1P	DDR0_QQS1P		IO	1.1 V					VDDS_DDR / VDDS_DDR_C0		DDR	
AE1	DDR0_QQS2N	DDR0_QQS2N		IO	1.1 V					VDDS_DDR / VDDS_DDR_C0		DDR	
AF1	DDR0_QQS2P	DDR0_QQS2P		IO	1.1 V					VDDS_DDR / VDDS_DDR_C0		DDR	
AH1	DDR0_QQS3N	DDR0_QQS3N		IO	1.1 V					VDDS_DDR / VDDS_DDR_C0		DDR	
AJ1	DDR0_QQS3P	DDR0_QQS3P		IO	1.1 V					VDDS_DDR / VDDS_DDR_C0		DDR	
F12	DDR1_CA0	DDR1_CA0		IO	1.1 V					VDDS_DDR / VDDS_DDR_C1		DDR	
C12	DDR1_CA1	DDR1_CA1		IO	1.1 V					VDDS_DDR / VDDS_DDR_C1		DDR	
B12	DDR1_CA2	DDR1_CA2		IO	1.1 V					VDDS_DDR / VDDS_DDR_C1		DDR	
C11	DDR1_CA3	DDR1_CA3		IO	1.1 V					VDDS_DDR / VDDS_DDR_C1		DDR	
D12	DDR1_CA4	DDR1_CA4		IO	1.1 V					VDDS_DDR / VDDS_DDR_C1		DDR	
E10	DDR1_CA5	DDR1_CA5		IO	1.1 V					VDDS_DDR / VDDS_DDR_C1		DDR	
G14	DDR1_CAL0	DDR1_CAL0		A	1.1 V					VDDS_DDR / VDDS_DDR_C1		DDR	
D11	DDR1_CKE0	DDR1_CKE0		IO	1.1 V					VDDS_DDR / VDDS_DDR_C1		DDR	
C10	DDR1_CKE1	DDR1_CKE1		IO	1.1 V					VDDS_DDR / VDDS_DDR_C1		DDR	

ADVANCE INFORMATION

**表 6-1. Pin Attributes (ALY Package) (continued)**

Ball Num [1]	Ball Name [2] PADCFG Register [15] PADCFG Address [16]	Signal Name [3]	Mux Mode [4]	Signal Type [5]	I/O Voltage [6]	Ball State DURING Reset (RX/TX/PULL) [7]	Ball State AFTER Reset (RX/TX/PULL) [8]	Mux Mode AFTER Reset [9]	Pull Type [10]	Power [11]	Hys [12]	Voltage Buffer Type [13]	IO RET [14]
E11	DDR1_CSn0_0	DDR1_CSn0_0		IO	1.1 V					VDDS_DDR / VDDS_DDR_C1		DDR	
G11	DDR1_CSn0_1	DDR1_CSn0_1		IO	1.1 V					VDDS_DDR / VDDS_DDR_C1		DDR	
F10	DDR1_CSn1_0	DDR1_CSn1_0		IO	1.1 V					VDDS_DDR / VDDS_DDR_C1		DDR	
G12	DDR1_CSn1_1	DDR1_CSn1_1		IO	1.1 V					VDDS_DDR / VDDS_DDR_C1		DDR	
E17	DDR1_DM0	DDR1_DM0		IO	1.1 V					VDDS_DDR / VDDS_DDR_C1		DDR	
C15	DDR1_DM1	DDR1_DM1		IO	1.1 V					VDDS_DDR / VDDS_DDR_C1		DDR	
D8	DDR1_DM2	DDR1_DM2		IO	1.1 V					VDDS_DDR / VDDS_DDR_C1		DDR	
C1	DDR1_DM3	DDR1_DM3		IO	1.1 V					VDDS_DDR / VDDS_DDR_C1		DDR	
F16	DDR1_DQ0	DDR1_DQ0		IO	1.1 V					VDDS_DDR / VDDS_DDR_C1		DDR	
G16	DDR1_DQ1	DDR1_DQ1		IO	1.1 V					VDDS_DDR / VDDS_DDR_C1		DDR	
F15	DDR1_DQ2	DDR1_DQ2		IO	1.1 V					VDDS_DDR / VDDS_DDR_C1		DDR	
E15	DDR1_DQ3	DDR1_DQ3		IO	1.1 V					VDDS_DDR / VDDS_DDR_C1		DDR	
D16	DDR1_DQ4	DDR1_DQ4		IO	1.1 V					VDDS_DDR / VDDS_DDR_C1		DDR	
C16	DDR1_DQ5	DDR1_DQ5		IO	1.1 V					VDDS_DDR / VDDS_DDR_C1		DDR	
B17	DDR1_DQ6	DDR1_DQ6		IO	1.1 V					VDDS_DDR / VDDS_DDR_C1		DDR	
D17	DDR1_DQ7	DDR1_DQ7		IO	1.1 V					VDDS_DDR / VDDS_DDR_C1		DDR	

表 6-1. Pin Attributes (ALY Package) (continued)

Ball Num [1]	Ball Name [2] PADCFG Register [15] PADCFG Address [16]	Signal Name [3]	Mux Mode [4]	Signal Type [5]	I/O Voltage [6]	Ball State DURING Reset (RX/TX/PULL) [7]	Ball State AFTER Reset (RX/TX/PULL) [8]	Mux Mode AFTER Reset [9]	Pull Type [10]	Power [11]	Hys [12]	Voltage Buffer Type [13]	IO RET [14]
B15	DDR1_DQ8	DDR1_DQ8		IO	1.1 V					VDDS_DDR / VDDS_DDR_C1		DDR	
B14	DDR1_DQ9	DDR1_DQ9		IO	1.1 V					VDDS_DDR / VDDS_DDR_C1		DDR	
C13	DDR1_DQ10	DDR1_DQ10		IO	1.1 V					VDDS_DDR / VDDS_DDR_C1		DDR	
D13	DDR1_DQ11	DDR1_DQ11		IO	1.1 V					VDDS_DDR / VDDS_DDR_C1		DDR	
F13	DDR1_DQ12	DDR1_DQ12		IO	1.1 V					VDDS_DDR / VDDS_DDR_C1		DDR	
G13	DDR1_DQ13	DDR1_DQ13		IO	1.1 V					VDDS_DDR / VDDS_DDR_C1		DDR	
E14	DDR1_DQ14	DDR1_DQ14		IO	1.1 V					VDDS_DDR / VDDS_DDR_C1		DDR	
D14	DDR1_DQ15	DDR1_DQ15		IO	1.1 V					VDDS_DDR / VDDS_DDR_C1		DDR	
E8	DDR1_DQ16	DDR1_DQ16		IO	1.1 V					VDDS_DDR / VDDS_DDR_C1		DDR	
G9	DDR1_DQ17	DDR1_DQ17		IO	1.1 V					VDDS_DDR / VDDS_DDR_C1		DDR	
F9	DDR1_DQ18	DDR1_DQ18		IO	1.1 V					VDDS_DDR / VDDS_DDR_C1		DDR	
D9	DDR1_DQ19	DDR1_DQ19		IO	1.1 V					VDDS_DDR / VDDS_DDR_C1		DDR	
C9	DDR1_DQ20	DDR1_DQ20		IO	1.1 V					VDDS_DDR / VDDS_DDR_C1		DDR	
B8	DDR1_DQ21	DDR1_DQ21		IO	1.1 V					VDDS_DDR / VDDS_DDR_C1		DDR	
B7	DDR1_DQ22	DDR1_DQ22		IO	1.1 V					VDDS_DDR / VDDS_DDR_C1		DDR	
C7	DDR1_DQ23	DDR1_DQ23		IO	1.1 V					VDDS_DDR / VDDS_DDR_C1		DDR	

ADVANCE INFORMATION

**表 6-1. Pin Attributes (ALY Package) (continued)**

Ball Num [1]	Ball Name [2] PADCFG Register [15] PADCFG Address [16]	Signal Name [3]	Mux Mode [4]	Signal Type [5]	I/O Voltage [6]	Ball State DURING Reset (RX/TX/PULL) [7]	Ball State AFTER Reset (RX/TX/PULL) [8]	Mux Mode AFTER Reset [9]	Pull Type [10]	Power [11]	Hys [12]	Voltage Buffer Type [13]	IO RET [14]
B2	DDR1_DQ24	DDR1_DQ24		IO	1.1 V					VDDS_DDR / VDDS_DDR_C1		DDR	
B3	DDR1_DQ25	DDR1_DQ25		IO	1.1 V					VDDS_DDR / VDDS_DDR_C1		DDR	
B4	DDR1_DQ26	DDR1_DQ26		IO	1.1 V					VDDS_DDR / VDDS_DDR_C1		DDR	
B5	DDR1_DQ27	DDR1_DQ27		IO	1.1 V					VDDS_DDR / VDDS_DDR_C1		DDR	
A6	DDR1_DQ28	DDR1_DQ28		IO	1.1 V					VDDS_DDR / VDDS_DDR_C1		DDR	
C5	DDR1_DQ29	DDR1_DQ29		IO	1.1 V					VDDS_DDR / VDDS_DDR_C1		DDR	
C6	DDR1_DQ30	DDR1_DQ30		IO	1.1 V					VDDS_DDR / VDDS_DDR_C1		DDR	
C3	DDR1_DQ31	DDR1_DQ31		IO	1.1 V					VDDS_DDR / VDDS_DDR_C1		DDR	
A17	DDR1_QS0N	DDR1_QS0N		IO	1.1 V					VDDS_DDR / VDDS_DDR_C1		DDR	
A16	DDR1_QS0P	DDR1_QS0P		IO	1.1 V					VDDS_DDR / VDDS_DDR_C1		DDR	
A14	DDR1_QS1N	DDR1_QS1N		IO	1.1 V					VDDS_DDR / VDDS_DDR_C1		DDR	
A13	DDR1_QS1P	DDR1_QS1P		IO	1.1 V					VDDS_DDR / VDDS_DDR_C1		DDR	
A9	DDR1_QS2N	DDR1_QS2N		IO	1.1 V					VDDS_DDR / VDDS_DDR_C1		DDR	
A8	DDR1_QS2P	DDR1_QS2P		IO	1.1 V					VDDS_DDR / VDDS_DDR_C1		DDR	
A4	DDR1_QS3N	DDR1_QS3N		IO	1.1 V					VDDS_DDR / VDDS_DDR_C1		DDR	
A3	DDR1_QS3P	DDR1_QS3P		IO	1.1 V					VDDS_DDR / VDDS_DDR_C1		DDR	

表 6-1. Pin Attributes (ALY Package) (continued)

Ball Num [1]	Ball Name [2] PADCFG Register [15] PADCFG Address [16]	Signal Name [3]	Mux Mode [4]	Signal Type [5]	I/O Voltage [6]	Ball State DURING Reset (RX/TX/PULL) [7]	Ball State AFTER Reset (RX/TX/PULL) [8]	Mux Mode AFTER Reset [9]	Pull Type [10]	Power [11]	Hys [12]	Voltage Buffer Type [13]	IO RET [14]
K3	DDR2_CA0	DDR2_CA0		IO	1.1 V					VDDS_DDR / VDDS_DDR_C2		DDR	
L3	DDR2_CA1	DDR2_CA1		IO	1.1 V					VDDS_DDR / VDDS_DDR_C2		DDR	
K5	DDR2_CA2	DDR2_CA2		IO	1.1 V					VDDS_DDR / VDDS_DDR_C2		DDR	
L4	DDR2_CA3	DDR2_CA3		IO	1.1 V					VDDS_DDR / VDDS_DDR_C2		DDR	
K4	DDR2_CA4	DDR2_CA4		IO	1.1 V					VDDS_DDR / VDDS_DDR_C2		DDR	
L7	DDR2_CA5	DDR2_CA5		IO	1.1 V					VDDS_DDR / VDDS_DDR_C2		DDR	
U7	DDR2_CAL0	DDR2_CAL0		A	1.1 V					VDDS_DDR / VDDS_DDR_C2		DDR	
L6	DDR2_CKE0	DDR2_CKE0		IO	1.1 V					VDDS_DDR / VDDS_DDR_C2		DDR	
J2	DDR2_CKE1	DDR2_CKE1		IO	1.1 V					VDDS_DDR / VDDS_DDR_C2		DDR	
J3	DDR2_CSn0_0	DDR2_CSn0_0		IO	1.1 V					VDDS_DDR / VDDS_DDR_C2		DDR	
J6	DDR2_CSn0_1	DDR2_CSn0_1		IO	1.1 V					VDDS_DDR / VDDS_DDR_C2		DDR	
J7	DDR2_CSn1_0	DDR2_CSn1_0		IO	1.1 V					VDDS_DDR / VDDS_DDR_C2		DDR	
K7	DDR2_CSn1_1	DDR2_CSn1_1		IO	1.1 V					VDDS_DDR / VDDS_DDR_C2		DDR	
T2	DDR2_DM0	DDR2_DM0		IO	1.1 V					VDDS_DDR / VDDS_DDR_C2		DDR	
M6	DDR2_DM1	DDR2_DM1		IO	1.1 V					VDDS_DDR / VDDS_DDR_C2		DDR	
G4	DDR2_DM2	DDR2_DM2		IO	1.1 V					VDDS_DDR / VDDS_DDR_C2		DDR	

ADVANCE INFORMATION



**表 6-1. Pin Attributes (ALY Package) (continued)**

Ball Num [1]	Ball Name [2] PADCFG Register [15] PADCFG Address [16]	Signal Name [3]	Mux Mode [4]	Signal Type [5]	I/O Voltage [6]	Ball State DURING Reset (RX/TX/PULL) [7]	Ball State AFTER Reset (RX/TX/PULL) [8]	Mux Mode AFTER Reset [9]	Pull Type [10]	Power [11]	Hys [12]	Voltage Buffer Type [13]	IO RET [14]
D5	DDR2_DM3	DDR2_DM3		IO	1.1 V					VDDS_DDR / VDDS_DDR_C2		DDR	
T4	DDR2_DQ0	DDR2_DQ0		IO	1.1 V					VDDS_DDR / VDDS_DDR_C2		DDR	
R6	DDR2_DQ1	DDR2_DQ1		IO	1.1 V					VDDS_DDR / VDDS_DDR_C2		DDR	
R3	DDR2_DQ2	DDR2_DQ2		IO	1.1 V					VDDS_DDR / VDDS_DDR_C2		DDR	
R4	DDR2_DQ3	DDR2_DQ3		IO	1.1 V					VDDS_DDR / VDDS_DDR_C2		DDR	
P6	DDR2_DQ4	DDR2_DQ4		IO	1.1 V					VDDS_DDR / VDDS_DDR_C2		DDR	
P5	DDR2_DQ5	DDR2_DQ5		IO	1.1 V					VDDS_DDR / VDDS_DDR_C2		DDR	
T5	DDR2_DQ6	DDR2_DQ6		IO	1.1 V					VDDS_DDR / VDDS_DDR_C2		DDR	
R7	DDR2_DQ7	DDR2_DQ7		IO	1.1 V					VDDS_DDR / VDDS_DDR_C2		DDR	
N2	DDR2_DQ8	DDR2_DQ8		IO	1.1 V					VDDS_DDR / VDDS_DDR_C2		DDR	
N4	DDR2_DQ9	DDR2_DQ9		IO	1.1 V					VDDS_DDR / VDDS_DDR_C2		DDR	
P2	DDR2_DQ10	DDR2_DQ10		IO	1.1 V					VDDS_DDR / VDDS_DDR_C2		DDR	
P3	DDR2_DQ11	DDR2_DQ11		IO	1.1 V					VDDS_DDR / VDDS_DDR_C2		DDR	
M7	DDR2_DQ12	DDR2_DQ12		IO	1.1 V					VDDS_DDR / VDDS_DDR_C2		DDR	
N5	DDR2_DQ13	DDR2_DQ13		IO	1.1 V					VDDS_DDR / VDDS_DDR_C2		DDR	
M4	DDR2_DQ14	DDR2_DQ14		IO	1.1 V					VDDS_DDR / VDDS_DDR_C2		DDR	

表 6-1. Pin Attributes (ALY Package) (continued)

Ball Num [1]	Ball Name [2] PADCFG Register [15] PADCFG Address [16]	Signal Name [3]	Mux Mode [4]	Signal Type [5]	I/O Voltage [6]	Ball State DURING Reset (RX/TX/PULL) [7]	Ball State AFTER Reset (RX/TX/PULL) [8]	Mux Mode AFTER Reset [9]	Pull Type [10]	Power [11]	Hys [12]	Voltage Buffer Type [13]	IO RET [14]
M3	DDR2_DQ15	DDR2_DQ15		IO	1.1 V					VDDS_DDR / VDDS_DDR_C2		DDR	
F3	DDR2_DQ16	DDR2_DQ16		IO	1.1 V					VDDS_DDR / VDDS_DDR_C2		DDR	
G7	DDR2_DQ17	DDR2_DQ17		IO	1.1 V					VDDS_DDR / VDDS_DDR_C2		DDR	
H6	DDR2_DQ18	DDR2_DQ18		IO	1.1 V					VDDS_DDR / VDDS_DDR_C2		DDR	
H4	DDR2_DQ19	DDR2_DQ19		IO	1.1 V					VDDS_DDR / VDDS_DDR_C2		DDR	
G2	DDR2_DQ20	DDR2_DQ20		IO	1.1 V					VDDS_DDR / VDDS_DDR_C2		DDR	
H3	DDR2_DQ21	DDR2_DQ21		IO	1.1 V					VDDS_DDR / VDDS_DDR_C2		DDR	
G5	DDR2_DQ22	DDR2_DQ22		IO	1.1 V					VDDS_DDR / VDDS_DDR_C2		DDR	
F2	DDR2_DQ23	DDR2_DQ23		IO	1.1 V					VDDS_DDR / VDDS_DDR_C2		DDR	
E4	DDR2_DQ24	DDR2_DQ24		IO	1.1 V					VDDS_DDR / VDDS_DDR_C2		DDR	
D2	DDR2_DQ25	DDR2_DQ25		IO	1.1 V					VDDS_DDR / VDDS_DDR_C2		DDR	
F6	DDR2_DQ26	DDR2_DQ26		IO	1.1 V					VDDS_DDR / VDDS_DDR_C2		DDR	
F5	DDR2_DQ27	DDR2_DQ27		IO	1.1 V					VDDS_DDR / VDDS_DDR_C2		DDR	
E3	DDR2_DQ28	DDR2_DQ28		IO	1.1 V					VDDS_DDR / VDDS_DDR_C2		DDR	
E7	DDR2_DQ29	DDR2_DQ29		IO	1.1 V					VDDS_DDR / VDDS_DDR_C2		DDR	
E6	DDR2_DQ30	DDR2_DQ30		IO	1.1 V					VDDS_DDR / VDDS_DDR_C2		DDR	

ADVANCE INFORMATION

**表 6-1. Pin Attributes (ALY Package) (continued)**

Ball Num [1]	Ball Name [2] PADCFG Register [15] PADCFG Address [16]	Signal Name [3]	Mux Mode [4]	Signal Type [5]	I/O Voltage [6]	Ball State DURING Reset (RX/TX/PULL) [7]	Ball State AFTER Reset (RX/TX/PULL) [8]	Mux Mode AFTER Reset [9]	Pull Type [10]	Power [11]	Hys [12]	Voltage Buffer Type [13]	IO RET [14]
D4	DDR2_DQ31	DDR2_DQ31		IO	1.1 V					VDD5_DDR / VDD5_DDR_C2		DDR	
R1	DDR2_DQS0N	DDR2_DQS0N		IO	1.1 V					VDD5_DDR / VDD5_DDR_C2		DDR	
T1	DDR2_DQS0P	DDR2_DQS0P		IO	1.1 V					VDD5_DDR / VDD5_DDR_C2		DDR	
M1	DDR2_DQS1N	DDR2_DQS1N		IO	1.1 V					VDD5_DDR / VDD5_DDR_C2		DDR	
N1	DDR2_DQS1P	DDR2_DQS1P		IO	1.1 V					VDD5_DDR / VDD5_DDR_C2		DDR	
G1	DDR2_DQS2N	DDR2_DQS2N		IO	1.1 V					VDD5_DDR / VDD5_DDR_C2		DDR	
H1	DDR2_DQS2P	DDR2_DQS2P		IO	1.1 V					VDD5_DDR / VDD5_DDR_C2		DDR	
D1	DDR2_DQS3N	DDR2_DQS3N		IO	1.1 V					VDD5_DDR / VDD5_DDR_C2		DDR	
E1	DDR2_DQS3P	DDR2_DQS3P		IO	1.1 V					VDD5_DDR / VDD5_DDR_C2		DDR	
D25	DDR3_CA0	DDR3_CA0		IO	1.1 V					VDD5_DDR / VDD5_DDR_C3		DDR	
B23	DDR3_CA1	DDR3_CA1		IO	1.1 V					VDD5_DDR / VDD5_DDR_C3		DDR	
D24	DDR3_CA2	DDR3_CA2		IO	1.1 V					VDD5_DDR / VDD5_DDR_C3		DDR	
C24	DDR3_CA3	DDR3_CA3		IO	1.1 V					VDD5_DDR / VDD5_DDR_C3		DDR	
E23	DDR3_CA4	DDR3_CA4		IO	1.1 V					VDD5_DDR / VDD5_DDR_C3		DDR	
F23	DDR3_CA5	DDR3_CA5		IO	1.1 V					VDD5_DDR / VDD5_DDR_C3		DDR	
F18	DDR3_CAL0	DDR3_CAL0		A	1.1 V					VDD5_DDR / VDD5_DDR_C3		DDR	

表 6-1. Pin Attributes (ALY Package) (continued)

Ball Num [1]	Ball Name [2] PADCFG Register [15] PADCFG Address [16]	Signal Name [3]	Mux Mode [4]	Signal Type [5]	I/O Voltage [6]	Ball State DURING Reset (RX/TX/PULL) [7]	Ball State AFTER Reset (RX/TX/PULL) [8]	Mux Mode AFTER Reset [9]	Pull Type [10]	Power [11]	Hys [12]	Voltage Buffer Type [13]	IO RET [14]
C25	DDR3_CKE0	DDR3_CKE0		IO	1.1 V					VDDS_DDR / VDDS_DDR_C3		DDR	
G24	DDR3_CKE1	DDR3_CKE1		IO	1.1 V					VDDS_DDR / VDDS_DDR_C3		DDR	
G23	DDR3_CSn0_0	DDR3_CSn0_0		IO	1.1 V					VDDS_DDR / VDDS_DDR_C3		DDR	
G25	DDR3_CSn0_1	DDR3_CSn0_1		IO	1.1 V					VDDS_DDR / VDDS_DDR_C3		DDR	
F25	DDR3_CSn1_0	DDR3_CSn1_0		IO	1.1 V					VDDS_DDR / VDDS_DDR_C3		DDR	
E24	DDR3_CSn1_1	DDR3_CSn1_1		IO	1.1 V					VDDS_DDR / VDDS_DDR_C3		DDR	
E18	DDR3_DM0	DDR3_DM0		IO	1.1 V					VDDS_DDR / VDDS_DDR_C3		DDR	
D21	DDR3_DM1	DDR3_DM1		IO	1.1 V					VDDS_DDR / VDDS_DDR_C3		DDR	
C28	DDR3_DM2	DDR3_DM2		IO	1.1 V					VDDS_DDR / VDDS_DDR_C3		DDR	
E30	DDR3_DM3	DDR3_DM3		IO	1.1 V					VDDS_DDR / VDDS_DDR_C3		DDR	
D18	DDR3_DQ0	DDR3_DQ0		IO	1.1 V					VDDS_DDR / VDDS_DDR_C3		DDR	
B18	DDR3_DQ1	DDR3_DQ1		IO	1.1 V					VDDS_DDR / VDDS_DDR_C3		DDR	
C19	DDR3_DQ2	DDR3_DQ2		IO	1.1 V					VDDS_DDR / VDDS_DDR_C3		DDR	
D19	DDR3_DQ3	DDR3_DQ3		IO	1.1 V					VDDS_DDR / VDDS_DDR_C3		DDR	
F20	DDR3_DQ4	DDR3_DQ4		IO	1.1 V					VDDS_DDR / VDDS_DDR_C3		DDR	
E20	DDR3_DQ5	DDR3_DQ5		IO	1.1 V					VDDS_DDR / VDDS_DDR_C3		DDR	

ADVANCE INFORMATION

**表 6-1. Pin Attributes (ALY Package) (continued)**

Ball Num [1]	Ball Name [2] PADCFG Register [15] PADCFG Address [16]	Signal Name [3]	Mux Mode [4]	Signal Type [5]	I/O Voltage [6]	Ball State DURING Reset (RX/TX/PULL) [7]	Ball State AFTER Reset (RX/TX/PULL) [8]	Mux Mode AFTER Reset [9]	Pull Type [10]	Power [11]	Hys [12]	Voltage Buffer Type [13]	IO RET [14]
G19	DDR3_DQ6	DDR3_DQ6		IO	1.1 V					VDDS_DDR / VDDS_DDR_C3		DDR	
F19	DDR3_DQ7	DDR3_DQ7		IO	1.1 V					VDDS_DDR / VDDS_DDR_C3		DDR	
E21	DDR3_DQ8	DDR3_DQ8		IO	1.1 V					VDDS_DDR / VDDS_DDR_C3		DDR	
G21	DDR3_DQ9	DDR3_DQ9		IO	1.1 V					VDDS_DDR / VDDS_DDR_C3		DDR	
F22	DDR3_DQ10	DDR3_DQ10		IO	1.1 V					VDDS_DDR / VDDS_DDR_C3		DDR	
D22	DDR3_DQ11	DDR3_DQ11		IO	1.1 V					VDDS_DDR / VDDS_DDR_C3		DDR	
C22	DDR3_DQ12	DDR3_DQ12		IO	1.1 V					VDDS_DDR / VDDS_DDR_C3		DDR	
B21	DDR3_DQ13	DDR3_DQ13		IO	1.1 V					VDDS_DDR / VDDS_DDR_C3		DDR	
B20	DDR3_DQ14	DDR3_DQ14		IO	1.1 V					VDDS_DDR / VDDS_DDR_C3		DDR	
C20	DDR3_DQ15	DDR3_DQ15		IO	1.1 V					VDDS_DDR / VDDS_DDR_C3		DDR	
B28	DDR3_DQ16	DDR3_DQ16		IO	1.1 V					VDDS_DDR / VDDS_DDR_C3		DDR	
B27	DDR3_DQ17	DDR3_DQ17		IO	1.1 V					VDDS_DDR / VDDS_DDR_C3		DDR	
C26	DDR3_DQ18	DDR3_DQ18		IO	1.1 V					VDDS_DDR / VDDS_DDR_C3		DDR	
D26	DDR3_DQ19	DDR3_DQ19		IO	1.1 V					VDDS_DDR / VDDS_DDR_C3		DDR	
F26	DDR3_DQ20	DDR3_DQ20		IO	1.1 V					VDDS_DDR / VDDS_DDR_C3		DDR	
G26	DDR3_DQ21	DDR3_DQ21		IO	1.1 V					VDDS_DDR / VDDS_DDR_C3		DDR	

表 6-1. Pin Attributes (ALY Package) (continued)

Ball Num [1]	Ball Name [2] PADCFG Register [15] PADCFG Address [16]	Signal Name [3]	Mux Mode [4]	Signal Type [5]	I/O Voltage [6]	Ball State DURING Reset (RX/TX/PULL) [7]	Ball State AFTER Reset (RX/TX/PULL) [8]	Mux Mode AFTER Reset [9]	Pull Type [10]	Power [11]	Hys [12]	Voltage Buffer Type [13]	IO RET [14]
E27	DDR3_DQ22	DDR3_DQ22		IO	1.1 V					VDDS_DDR / VDDS_DDR_C3		DDR	
D27	DDR3_DQ23	DDR3_DQ23		IO	1.1 V					VDDS_DDR / VDDS_DDR_C3		DDR	
F29	DDR3_DQ24	DDR3_DQ24		IO	1.1 V					VDDS_DDR / VDDS_DDR_C3		DDR	
G29	DDR3_DQ25	DDR3_DQ25		IO	1.1 V					VDDS_DDR / VDDS_DDR_C3		DDR	
F28	DDR3_DQ26	DDR3_DQ26		IO	1.1 V					VDDS_DDR / VDDS_DDR_C3		DDR	
E28	DDR3_DQ27	DDR3_DQ27		IO	1.1 V					VDDS_DDR / VDDS_DDR_C3		DDR	
D29	DDR3_DQ28	DDR3_DQ28		IO	1.1 V					VDDS_DDR / VDDS_DDR_C3		DDR	
C29	DDR3_DQ29	DDR3_DQ29		IO	1.1 V					VDDS_DDR / VDDS_DDR_C3		DDR	
B30	DDR3_DQ30	DDR3_DQ30		IO	1.1 V					VDDS_DDR / VDDS_DDR_C3		DDR	
D30	DDR3_DQ31	DDR3_DQ31		IO	1.1 V					VDDS_DDR / VDDS_DDR_C3		DDR	
A19	DDR3_DQS0N	DDR3_DQS0N		IO	1.1 V					VDDS_DDR / VDDS_DDR_C3		DDR	
A18	DDR3_DQS0P	DDR3_DQS0P		IO	1.1 V					VDDS_DDR / VDDS_DDR_C3		DDR	
A22	DDR3_DQS1N	DDR3_DQS1N		IO	1.1 V					VDDS_DDR / VDDS_DDR_C3		DDR	
A21	DDR3_DQS1P	DDR3_DQS1P		IO	1.1 V					VDDS_DDR / VDDS_DDR_C3		DDR	
A27	DDR3_DQS2N	DDR3_DQS2N		IO	1.1 V					VDDS_DDR / VDDS_DDR_C3		DDR	
A26	DDR3_DQS2P	DDR3_DQS2P		IO	1.1 V					VDDS_DDR / VDDS_DDR_C3		DDR	

ADVANCE INFORMATION

**表 6-1. Pin Attributes (ALY Package) (continued)**

Ball Num [1]	Ball Name [2] PADCFG Register [15] PADCFG Address [16]	Signal Name [3]	Mux Mode [4]	Signal Type [5]	I/O Voltage [6]	Ball State DURING Reset (RX/TX/PULL) [7]	Ball State AFTER Reset (RX/TX/PULL) [8]	Mux Mode AFTER Reset [9]	Pull Type [10]	Power [11]	Hys [12]	Voltage Buffer Type [13]	IO RET [14]
A30	DDR3_DQS3N	DDR3_DQS3N		IO	1.1 V					VDD5_DDR / VDD5_DDR_C3		DDR	
A29	DDR3_DQS3P	DDR3_DQS3P		IO	1.1 V					VDD5_DDR / VDD5_DDR_C3		DDR	
AP22	DP0_AUXN	DP0_AUXN		IO	1.8 V					VDDA_1P8_S ERDES2_4		AUX-PHY	
AP23	DP0_AUXP	DP0_AUXP		IO	1.8 V					VDDA_1P8_S ERDES2_4		AUX-PHY	
AP26	DSI0_TXCLKN	CSI0_TXCLKN		O	1.8 V					VDDA_0P8_D SITX / VDDA_0P8_D SITX_C / VDDA_1P8_D SITX		D-PHY	
		DSI0_TXCLKN		O									
AP25	DSI0_TXCLKP	DSI0_TXCLKP		O	1.8 V					VDDA_0P8_D SITX / VDDA_0P8_D SITX_C / VDDA_1P8_D SITX		D-PHY	
		CSI0_TXCLKP		O									
AM24	DSI0_TXRCALIB	DSI0_TXRCALIB		A	1.8 V					VDDA_0P8_D SITX / VDDA_0P8_D SITX_C / VDDA_1P8_D SITX		D-PHY	
AP29	DSI1_TXCLKN	DSI1_TXCLKN		O	1.8 V					VDDA_0P8_D SITX / VDDA_0P8_D SITX_C / VDDA_1P8_D SITX		D-PHY	
		CSI1_TXCLKN		O									
AP28	DSI1_TXCLKP	DSI1_TXCLKP		O	1.8 V					VDDA_0P8_D SITX / VDDA_0P8_D SITX_C / VDDA_1P8_D SITX		D-PHY	
		CSI1_TXCLKP		O									
AL22	DSI1_TXRCALIB	DSI1_TXRCALIB		A	1.8 V					VDDA_0P8_D SITX / VDDA_0P8_D SITX_C / VDDA_1P8_D SITX		D-PHY	
AU27	DSI0_TXN0	CSI0_TXN0		O	1.8 V					VDDA_0P8_D SITX / VDDA_0P8_D SITX_C / VDDA_1P8_D SITX		D-PHY	
		DSI0_TXN0		IO									

**表 6-1. Pin Attributes (ALY Package) (continued)**

Ball Num [1]	Ball Name [2] PADCFG Register [15] PADCFG Address [16]	Signal Name [3]	Mux Mode [4]	Signal Type [5]	I/O Voltage [6]	Ball State DURING Reset (RX/TX/PULL) [7]	Ball State AFTER Reset (RX/TX/PULL) [8]	Mux Mode AFTER Reset [9]	Pull Type [10]	Power [11]	Hys [12]	Voltage Buffer Type [13]	IO RET [14]
AT26	DSI0_TXN1	CSI0_TXN1		O	1.8 V					VDDA_0P8_D SITX /		D-PHY	
		DSI0_TXN1		O						VDDA_0P8_D SITX_C / VDDA_1P8_D SITX			
AR27	DSI0_TXN2	DSI0_TXN2		O	1.8 V					VDDA_0P8_D SITX /		D-PHY	
		CSI0_TXN2		O						VDDA_0P8_D SITX_C / VDDA_1P8_D SITX			
AN24	DSI0_TXN3	DSI0_TXN3		O	1.8 V					VDDA_0P8_D SITX /		D-PHY	
		CSI0_TXN3		O						VDDA_0P8_D SITX_C / VDDA_1P8_D SITX			
AU26	DSI0_TXP0	CSI0_TXP0		O	1.8 V					VDDA_0P8_D SITX /		D-PHY	
		DSI0_TXP0		IO						VDDA_0P8_D SITX_C / VDDA_1P8_D SITX			
AT25	DSI0_TXP1	CSI0_TXP1		O	1.8 V					VDDA_0P8_D SITX /		D-PHY	
		DSI0_TXP1		O						VDDA_0P8_D SITX_C / VDDA_1P8_D SITX			
AR26	DSI0_TXP2	DSI0_TXP2		O	1.8 V					VDDA_0P8_D SITX /		D-PHY	
		CSI0_TXP2		O						VDDA_0P8_D SITX_C / VDDA_1P8_D SITX			
AN23	DSI0_TXP3	DSI0_TXP3		O	1.8 V					VDDA_0P8_D SITX /		D-PHY	
		CSI0_TXP3		O						VDDA_0P8_D SITX_C / VDDA_1P8_D SITX			
AT29	DSI1_TXN0	CSI1_TXN0		O	1.8 V					VDDA_0P8_D SITX /		D-PHY	
		DSI1_TXN0		IO						VDDA_0P8_D SITX_C / VDDA_1P8_D SITX			

**ADVANCE INFORMATION**



**表 6-1. Pin Attributes (ALY Package) (continued)**

Ball Num [1]	Ball Name [2] PADCFG Register [15] PADCFG Address [16]	Signal Name [3]	Mux Mode [4]	Signal Type [5]	I/O Voltage [6]	Ball State DURING Reset (RX/TX/PULL) [7]	Ball State AFTER Reset (RX/TX/PULL) [8]	Mux Mode AFTER Reset [9]	Pull Type [10]	Power [11]	Hys [12]	Voltage Buffer Type [13]	IO RET [14]
AN27	DSI1_TXN1	CSI1_TXN1		O	1.8 V					VDDA_0P8_D SITX / VDDA_0P8_D SITX_C / VDDA_1P8_D SITX		D-PHY	
		DSI1_TXN1		O									
AV28	DSI1_TXN2	CSI1_TXN2		O	1.8 V					VDDA_0P8_D SITX / VDDA_0P8_D SITX_C / VDDA_1P8_D SITX		D-PHY	
		DSI1_TXN2		O									
AU30	DSI1_TXN3	CSI1_TXN3		O	1.8 V					VDDA_0P8_D SITX / VDDA_0P8_D SITX_C / VDDA_1P8_D SITX		D-PHY	
		DSI1_TXN3		O									
AT28	DSI1_TXP0	DSI1_TXP0		IO	1.8 V					VDDA_0P8_D SITX / VDDA_0P8_D SITX_C / VDDA_1P8_D SITX		D-PHY	
		CSI1_TXP0		O									
AN26	DSI1_TXP1	CSI1_TXP1		O	1.8 V					VDDA_0P8_D SITX / VDDA_0P8_D SITX_C / VDDA_1P8_D SITX		D-PHY	
		DSI1_TXP1		O									
AV27	DSI1_TXP2	DSI1_TXP2		O	1.8 V					VDDA_0P8_D SITX / VDDA_0P8_D SITX_C / VDDA_1P8_D SITX		D-PHY	
		CSI1_TXP2		O									
AU29	DSI1_TXP3	CSI1_TXP3		O	1.8 V					VDDA_0P8_D SITX / VDDA_0P8_D SITX_C / VDDA_1P8_D SITX		D-PHY	
		DSI1_TXP3		O									

**表 6-1. Pin Attributes (ALY Package) (continued)**

Ball Num [1]	Ball Name [2] PADCFG Register [15] PADCFG Address [16]	Signal Name [3]	Mux Mode [4]	Signal Type [5]	I/O Voltage [6]	Ball State DURING Reset (RX/TX/PULL) [7]	Ball State AFTER Reset (RX/TX/PULL) [8]	Mux Mode AFTER Reset [9]	Pull Type [10]	Power [11]	Hys [12]	Voltage Buffer Type [13]	IO RET [14]
AD36	ECAP0_IN_APWM_OUT PADCFG: PADCONFIG_49 0x0011C0C4	ECAP0_IN_APWM_OUT	0	IO	1.8 V/3.3 V	Off / Off / Off	Off / Off / Off	7	PU/PD	VDDSHV2	Yes	LVCMOS	Yes
		MCASP4_AXR2	1	IO									
		CPTS0_RFT_CLK	2	I									
		HYP1_TXFLCLK	3	I									
		MCAN12_TX	4	O									
		VOU0_DATA23	5	O									
		GPMC0_AD5	6	IO									
		GPIO0_49	7	IO									
		SPI6_D0	8	IO									
		SYNC0_OUT	9	O									
		TRC_DATA1	10	O									
		UART2_CTSn	11	I									
		CPTS0_HW1TSPUSH	12	I									
		I2C1_SCL	13	IOD									
UART3_RXD	14	I											
F35	EMU0 PADCFG: WKUP_PADCONFIG_75 0x4301C12C	EMU0	0	IO	1.8 V/3.3 V	On / Off / Up	On / Off / Up	0	PU/PD	VDDSHV0_MCU	Yes	LVCMOS	No
H34	EMU1 PADCFG: WKUP_PADCONFIG_76 0x4301C130	EMU1	0	IO	1.8 V/3.3 V	On / Off / Up	On / Off / Up	0	PU/PD	VDDSHV0_MCU	Yes	LVCMOS	No
		MCU_OBSCLK0	15	O									
AN35	EXTINTn PADCFG: PADCONFIG_0 0x0011C000	EXTINTn	0	I	1.8 V/3.3 V	Off / Off / Off	Off / SS / Off	7		VDDSHV0	Yes	I2C OPEN DRAIN	No
		GPIO0_0	7	IO									

ADVANCE INFORMATION

**表 6-1. Pin Attributes (ALY Package) (continued)**

Ball Num [1]	Ball Name [2] PADCFG Register [15] PADCFG Address [16]	Signal Name [3]	Mux Mode [4]	Signal Type [5]	I/O Voltage [6]	Ball State DURING Reset (RX/TX/PULL) [7]	Ball State AFTER Reset (RX/TX/PULL) [8]	Mux Mode AFTER Reset [9]	Pull Type [10]	Power [11]	Hys [12]	Voltage Buffer Type [13]	IO RET [14]
AJ32	EXT_REFCLK1 PADCFG: PADCONFIG_50 0x0011C0C8	EXT_REFCLK1	0	I	1.8 V/3.3 V	Off / Off / Off	Off / Off / Off	7	PU/PD	VDDSHV2	Yes	LVC MOS	Yes
		MCASP4_ACLKX	1	IO									
		VOU0_DATA16	2	O									
		HYP1_TXFLDAT	3	I									
		MCAN1_RX	4	I									
		GPMC0_AD6	6	IO									
		GPIO0_50	7	IO									
		SYNC1_OUT	9	O									
		TRC_CLK	10	O									
		UART2_RTSn	11	O									
		CPTS0_HW2TSPUSH	12	I									
		I2C1_SDA	13	IOD									
		UART3_TXD	14	O									
		AL32	GPIO0_11 PADCFG: PADCONFIG_11 0x0011C02C	MCAN17_TX									
VOU0_DATA18	2			O									
GPMC0_A14	6			OZ									
GPIO0_11	7			IO									
SPI7_CS3	8			IO									
TRC_DATA25	10			O									
GPMC0_CSn2	12			O									
UART7_RXD	13			I									
USB0_DRVVBUS	14			O									
AK37	GPIO0_12 PADCFG: PADCONFIG_12 0x0011C030	MCAN12_RX	0	I	1.8 V/3.3 V	Off / Off / Off	Off / Off / Off	7	PU/PD	VDDSHV2	Yes	LVC MOS	Yes
		VOU0_DATA17	2	O									
		HYP1_RXFLDAT	3	O									
		VOU0_DATA22	5	O									
		GPMC0_AD4	6	IO									
		GPIO0_12	7	IO									
		SPI6_CLK	8	IO									
		EQEP1_I	9	IO									
		TRC_DATA2	10	O									
		UART9_CTSn	11	I									
		UART6_RXD	12	I									
AN36	I2C0_SCL PADCFG: PADCONFIG_56 0x0011C0E0	I2C0_SCL	0	IOD	1.8 V/3.3 V	Off / Off / Off	On / SS / Off	7		VDDSHV0	Yes	I2C OPEN DRAIN	No
		GPIO0_56	7	IO									

**表 6-1. Pin Attributes (ALY Package) (continued)**

Ball Num [1]	Ball Name [2] PADCFG Register [15] PADCFG Address [16]	Signal Name [3]	Mux Mode [4]	Signal Type [5]	I/O Voltage [6]	Ball State DURING Reset (RX/TX/PULL) [7]	Ball State AFTER Reset (RX/TX/PULL) [8]	Mux Mode AFTER Reset [9]	Pull Type [10]	Power [11]	Hys [12]	Voltage Buffer Type [13]	IO RET [14]
AP37	I2C0_SDA PADCFG: PADCONFIG_57 0x0011C0E4	I2C0_SDA	0	IOD	1.8 V/3.3 V	Off / Off / Off	On / SS / Off	7		VDDSHV0	Yes	I2C OPEN DRAIN	No
		GPIO0_57	7	IO									
AE38	MCAN0_RX PADCFG: PADCONFIG_26 0x0011C068	MCAN0_RX	0	I	1.8 V/3.3 V	Off / Off / Off	Off / Off / Off	7	PU/PD	VDDSHV2	Yes	LVC MOS	Yes
		MCASP4_AXR1	1	IO									
		VOUT0_DATA3	2	O									
		GPMC0_AD15	6	IO									
		GPIO0_26	7	IO									
		SPI5_CS0	8	IO									
		EHRPWM0_A	9	IO									
		TRC_DATA16	10	O									
		UART2_TXD	11	O									
		UART6_RTSn	12	O									
SPI7_D0	13	IO											
AF38	MCAN0_TX PADCFG: PADCONFIG_25 0x0011C064	MCAN0_TX	0	O	1.8 V/3.3 V	Off / Off / Off	Off / Off / Off	7	PU/PD	VDDSHV2	Yes	LVC MOS	Yes
		MCASP2_AXR2	1	IO									
		VOUT0_DATA4	2	O									
		GPMC0_AD14	6	IO									
		GPIO0_25	7	IO									
		SPI5_CS1	8	IO									
		EHRPWM0_B	9	IO									
		TRC_DATA11	10	O									
		UART2_RXD	11	I									
		UART6_CTSn	12	I									
I2C3_SCL	13	IOD											
AH38	MCAN1_RX PADCFG: PADCONFIG_28 0x0011C070	MCAN1_RX	0	I	1.8 V/3.3 V	Off / Off / Off	Off / Off / Off	7	PU/PD	VDDSHV2	Yes	LVC MOS	Yes
		MCASP4_AXR3	1	IO									
		VOUT0_DATA1	2	O									
		VOUT0_DATA19	5	O									
		GPMC0_BE0n_CLE	6	O									
		GPIO0_28	7	IO									
		SPI5_D0	8	IO									
		EHRPWM0_SYNCI	9	I									
		TRC_DATA5	10	O									
		UART3_RTSn	11	O									

**ADVANCE INFORMATION**

**表 6-1. Pin Attributes (ALY Package) (continued)**

Ball Num [1]	Ball Name [2] PADCFG Register [15] PADCFG Address [16]	Signal Name [3]	Mux Mode [4]	Signal Type [5]	I/O Voltage [6]	Ball State DURING Reset (RX/TX/PULL) [7]	Ball State AFTER Reset (RX/TX/PULL) [8]	Mux Mode AFTER Reset [9]	Pull Type [10]	Power [11]	Hys [12]	Voltage Buffer Type [13]	IO RET [14]
AJ37	MCAN1_TX PADCFG: PADCONFIG_27 0x0011C06C	MCAN1_TX	0	O	1.8 V/3.3 V	Off / Off / Off	Off / Off / Off	7	PU/PD	VDDSHV2	Yes	LVCMOS	Yes
		MCASP4_AFSX	1	IO									
		VOUT0_EXTPLCKIN	2	I									
		HYP1_TXPMCLK	3	O									
		DSS_FSYNCO	4	O									
		GPMC0_AD7	6	IO									
		GPIO0_27	7	IO									
		EHRPWM_TZn_IN5	9	I									
		TRC_CTL	10	O									
UART6_TXD	11	O											
AH37	MCAN2_RX PADCFG: PADCONFIG_30 0x0011C078	MCAN2_RX	0	I	1.8 V/3.3 V	Off / Off / Off	Off / Off / Off	7	PU/PD	VDDSHV2	Yes	LVCMOS	Yes
		AUDIO_EXT_REFCLK1	1	IO									
		VOUT0_PCLK	2	O									
		GPMC0_CSn1	6	O									
		GPIO0_30	7	IO									
		SPI6_CS1	8	IO									
		EHRPWM4_B	9	IO									
		TRC_DATA17	10	O									
		UART3_TXD	11	O									
		GPMC0_DIR	12	O									
		I2C5_SDA	13	IOD									
AC33	MCAN2_TX PADCFG: PADCONFIG_29 0x0011C074	MCAN2_TX	0	O	1.8 V/3.3 V	Off / Off / Off	Off / Off / Off	7	PU/PD	VDDSHV2	Yes	LVCMOS	Yes
		MCASP2_AXR3	1	IO									
		VOUT0_DATA0	2	O									
		VOUT0_DATA18	5	O									
		GPMC0_WAIT0	6	I									
		GPIO0_29	7	IO									
		SPI6_D1	8	IO									
		EHRPWM1_B	9	IO									
		TRC_DATA3	10	O									
		UART3_RXD	11	I									
		GPMC0_DIR	12	O									
I2C5_SCL	13	IOD											

**表 6-1. Pin Attributes (ALY Package) (continued)**

Ball Num [1]	Ball Name [2] PADCFG Register [15] PADCFG Address [16]	Signal Name [3]	Mux Mode [4]	Signal Type [5]	I/O Voltage [6]	Ball State DURING Reset (RX/TX/PULL) [7]	Ball State AFTER Reset (RX/TX/PULL) [8]	Mux Mode AFTER Reset [9]	Pull Type [10]	Power [11]	Hys [12]	Voltage Buffer Type [13]	IO RET [14]
AJ33	MCAN12_RX PADCFG: PADCONFIG_2 0x0011C008	MCAN12_RX	0	I	1.8 V/3.3 V	Off / Off / Off	Off / Off / Off	7	PU/PD	VDDSHV2	Yes	LVCMOS	Yes
		UART0_DCDn	1	I									
		DSS_FSYNC1	3	O									
		GPMC0_A23	6	OZ									
		GPIO0_2	7	IO									
		TRC_CTL	10	O									
		UART5_RXD	11	I									
GPMC0_CSn3	12	O											
AG36	MCAN12_TX PADCFG: PADCONFIG_1 0x0011C004	MCAN12_TX	0	O	1.8 V/3.3 V	Off / Off / Off	Off / Off / Off	7	PU/PD	VDDSHV2	Yes	LVCMOS	Yes
		DSS_FSYNC0	3	O									
		GPMC0_A24	6	OZ									
		GPIO0_1	7	IO									
		TRC_CLK	10	O									
		UART5_TXD	11	O									
GPMC0_CLK	12	IO											
AH33	MCAN13_RX PADCFG: PADCONFIG_4 0x0011C010	MCAN13_RX	0	I	1.8 V/3.3 V	Off / Off / Off	Off / Off / Off	7	PU/PD	VDDSHV2	Yes	LVCMOS	Yes
		UART0_DTRn	1	O									
		DSS_FSYNC3	3	O									
		GPMC0_A21	6	OZ									
		GPIO0_4	7	IO									
		I2C4_SDA	8	IOD									
		TRC_DATA1	10	O									
UART6_TXD	11	O											
AF33	MCAN13_TX PADCFG: PADCONFIG_3 0x0011C00C	MCAN13_TX	0	O	1.8 V/3.3 V	Off / Off / Off	Off / Off / Off	7	PU/PD	VDDSHV2	Yes	LVCMOS	Yes
		UART0_DSRn	1	I									
		DSS_FSYNC2	3	O									
		GPMC0_A22	6	OZ									
		GPIO0_3	7	IO									
		TRC_DATA0	10	O									
		UART4_TXD	11	O									
GPMC0_WAIT2	12	I											

**ADVANCE INFORMATION**

**表 6-1. Pin Attributes (ALY Package) (continued)**

Ball Num [1]	Ball Name [2] PADCFG Register [15] PADCFG Address [16]	Signal Name [3]	Mux Mode [4]	Signal Type [5]	I/O Voltage [6]	Ball State DURING Reset (RX/TX/PULL) [7]	Ball State AFTER Reset (RX/TX/PULL) [8]	Mux Mode AFTER Reset [9]	Pull Type [10]	Power [11]	Hys [12]	Voltage Buffer Type [13]	IO RET [14]
AK36	MCAN14_RX PADCFG: PADCONFIG_6 0x0011C018	MCAN14_RX	0	I	1.8 V/3.3 V	Off / Off / Off	Off / Off / Off	7	PU/PD	VDDSHV2	Yes	LVC MOS	Yes
		VOUT0_DATA23	2	O									
		GPMC0_A19	6	OZ									
		GPIO0_6	7	IO									
		I2C5_SDA	8	IOD									
		TRC_DATA3	10	O									
		UART9_TXD	11	O									
AG33	MCAN14_TX PADCFG: PADCONFIG_5 0x0011C014	MCAN14_TX	0	O	1.8 V/3.3 V	Off / Off / Off	Off / Off / Off	7	PU/PD	VDDSHV2	Yes	LVC MOS	Yes
		UART0_RIn	1	I									
		GPMC0_A20	6	OZ									
		GPIO0_5	7	IO									
		I2C4_SCL	8	IOD									
		TRC_DATA2	10	O									
		UART6_RXD	11	I									
DP0_HPDP	13	I											
AJ35	MCAN15_RX PADCFG: PADCONFIG_8 0x0011C020	MCAN15_RX	0	I	1.8 V/3.3 V	Off / Off / Off	Off / Off / Off	7	PU/PD	VDDSHV2	Yes	LVC MOS	Yes
		VOUT0_DATA21	2	O									
		GPMC0_A17	6	OZ									
		GPIO0_8	7	IO									
		SPI0_CS2	8	IO									
		TRC_DATA22	10	O									
		I2C1_SCL	12	IOD									
AG34	MCAN15_TX PADCFG: PADCONFIG_7 0x0011C01C	MCAN15_TX	0	O	1.8 V/3.3 V	Off / Off / Off	Off / Off / Off	7	PU/PD	VDDSHV2	Yes	LVC MOS	Yes
		VOUT0_DATA22	2	O									
		GPMC0_A18	6	OZ									
		GPIO0_7	7	IO									
		I2C5_SCL	8	IOD									
		TRC_DATA21	10	O									
		UART9_RXD	11	I									
AE33	MCAN16_RX PADCFG: PADCONFIG_10 0x0011C028	MCAN16_RX	0	I	1.8 V/3.3 V	Off / Off / Off	Off / Off / Off	7	PU/PD	VDDSHV2	Yes	LVC MOS	Yes
		VOUT0_DATA19	2	O									
		GPMC0_A15	6	OZ									
		GPIO0_10	7	IO									
		SPI0_CS3	8	IO									
		TRC_DATA24	10	O									
		GPMC0_WAIT1	12	I									

**表 6-1. Pin Attributes (ALY Package) (continued)**

Ball Num [1]	Ball Name [2] PADCFG Register [15] PADCFG Address [16]	Signal Name [3]	Mux Mode [4]	Signal Type [5]	I/O Voltage [6]	Ball State DURING Reset (RX/TX/PULL) [7]	Ball State AFTER Reset (RX/TX/PULL) [8]	Mux Mode AFTER Reset [9]	Pull Type [10]	Power [11]	Hys [12]	Voltage Buffer Type [13]	IO RET [14]
AH34	MCAN16_TX PADCFG: PADCONFIG_9 0x0011C024	MCAN16_TX	0	O	1.8 V/3.3 V	Off / Off / Off	Off / Off / Off	7	PU/PD	VDDSHV2	Yes	LVC MOS	Yes
		VOUT0_DATA20	2	O									
		GPMC0_A16	6	OZ									
		GPIO0_9	7	IO									
		SPI1_CS3	8	IO									
		TRC_DATA23	10	O									
		I2C1_SDA	12	IOD									
AK35	MCASP0_ACLKX PADCFG: PADCONFIG_14 0x0011C038	MCAN5_TX	0	O	1.8 V/3.3 V	Off / Off / Off	Off / Off / Off	7	PU/PD	VDDSHV2	Yes	LVC MOS	Yes
		MCASP0_ACLKX	1	IO									
		VOUT0_DATA15	2	O									
		HYP0_RXFLCLK	3	O									
		GPMC0_AD0	6	IO									
		GPIO0_14	7	IO									
		EHRPWM_TZn_IN2	9	I									
UART8_RXD	11	I											
AK38	MCASP0_AFSX PADCFG: PADCONFIG_15 0x0011C03C	MCAN5_RX	0	I	1.8 V/3.3 V	Off / Off / Off	Off / Off / Off	7	PU/PD	VDDSHV2	Yes	LVC MOS	Yes
		MCASP0_AFSX	1	IO									
		VOUT0_DATA14	2	O									
		HYP0_RXFLDAT	3	O									
		GPMC0_AD1	6	IO									
		GPIO0_15	7	IO									
		EHRPWM2_B	9	IO									
UART8_TXD	11	O											
AC34	MCASP1_ACLKX PADCFG: PADCONFIG_46 0x0011C0B8	MCAN10_RX	0	I	1.8 V/3.3 V	Off / Off / Off	Off / Off / Off	7	PU/PD	VDDSHV2	Yes	LVC MOS	Yes
		MCASP1_ACLKX	1	IO									
		DP0_HPD	3	I									
		PCIE0_CLKREQn	4	IO									
		GPMC0_A11	5	OZ									
		RGMI1_RD0	6	I									
		GPIO0_46	7	IO									
		EQEP0_S	9	IO									
		UART4_RTSn	11	O									
		SPI3_CS3	12	IO									
UART9_RTSn	13	O											

ADVANCE INFORMATION



**表 6-1. Pin Attributes (ALY Package) (continued)**

Ball Num [1]	Ball Name [2] PADCFG Register [15] PADCFG Address [16]	Signal Name [3]	Mux Mode [4]	Signal Type [5]	I/O Voltage [6]	Ball State DURING Reset (RX/TX/PULL) [7]	Ball State AFTER Reset (RX/TX/PULL) [8]	Mux Mode AFTER Reset [9]	Pull Type [10]	Power [11]	Hys [12]	Voltage Buffer Type [13]	IO RET [14]
AD33	MCASP1_AFSX PADCFG: PADCONFIG_47 0x0011C0BC	MCAN11_TX	0	O	1.8 V/3.3 V	Off / Off / Off	Off / Off / Off	7	PU/PD	VDDSHV2	Yes	LVCMOS	Yes
		MCASP1_AFSX	1	IO									
		GPMC0_A12	5	OZ									
		MDIO0_MDIO	6	IO									
		GPIO0_47	7	IO									
		SPI3_CS0	8	IO									
		EQEP0_I	9	IO									
		UART0_RXD	11	I									
AD37	MCASP2_ACLKX PADCFG: PADCONFIG_21 0x0011C054	MCAN8_RX	0	I	1.8 V/3.3 V	Off / Off / Off	Off / Off / Off	7	PU/PD	VDDSHV2	Yes	LVCMOS	Yes
		MCASP2_ACLKX	1	IO									
		VOUT0_DATA8	2	O									
		HYP0_TXPMCLK	3	O									
		VOUT0_DATA20	5	O									
		GPMC0_AD10	6	IO									
		GPIO0_21	7	IO									
		SPI5_CS2	8	IO									
		EQEP2_S	9	IO									
		TRC_DATA4	10	O									
		UART1_RXD	11	I									
		SPI7_CS1	13	IO									
		SYNC3_OUT	14	O									
		AE37	MCASP2_AFSX PADCFG: PADCONFIG_22 0x0011C058	MCAN9_TX									
MCASP2_AFSX	1			IO									
VOUT0_DATA7	2			O									
HYP0_TXPMDAT	3			O									
MDIO1_MDC	4			O									
GPMC0_AD11	6			IO									
GPIO0_22	7			IO									
SPI5_CS3	8			IO									
EHRPWM_SOCA	9			O									
TRC_DATA9	10			O									
UART1_TXD	11			O									
SPI7_CS2	13			IO									

**表 6-1. Pin Attributes (ALY Package) (continued)**

Ball Num [1]	Ball Name [2] PADCFG Register [15] PADCFG Address [16]	Signal Name [3]	Mux Mode [4]	Signal Type [5]	I/O Voltage [6]	Ball State DURING Reset (RX/TX/PULL) [7]	Ball State AFTER Reset (RX/TX/PULL) [8]	Mux Mode AFTER Reset [9]	Pull Type [10]	Power [11]	Hys [12]	Voltage Buffer Type [13]	IO RET [14]
AF37	MCASP0_AXR0 PADCFG: PADCONFIG_16 0x0011C040	MCAN6_TX	0	O	1.8 V/3.3 V	Off / Off / Off	Off / Off / Off	7	PU/PD	VDDSHV2	Yes	LVCMOS	Yes
		MCASP0_AXR0	1	IO									
		VOUT0_DATA13	2	O									
		HYP0_TXFLCLK	3	I									
		GPMC0_AD2	6	IO									
		GPIO0_16	7	IO									
		SPI2_CS2	8	IO									
		EHRPWM2_A	9	IO									
		TRC_DATA14	10	O									
		UART4_RXD	11	I									
		SPI7_CLK	13	IO									
		UART8_CTSn	14	I									
AG37	MCASP0_AXR1 PADCFG: PADCONFIG_17 0x0011C044	MCAN6_RX	0	I	1.8 V/3.3 V	Off / Off / Off	Off / Off / Off	7	PU/PD	VDDSHV2	Yes	LVCMOS	Yes
		MCASP0_AXR1	1	IO									
		VOUT0_DATA12	2	O									
		HYP0_TXFLDAT	3	I									
		OBCLK1	4	O									
		GPMC0_AD3	6	IO									
		GPIO0_17	7	IO									
		SPI2_CS3	8	IO									
		EHRPWM0_SYNCO	9	O									
		TRC_DATA12	10	O									
		UART4_TXD	11	O									
		SPI7_CS0	13	IO									
UART8_RTSn	14	O											
AK33	MCASP0_AXR2 PADCFG: PADCONFIG_18 0x0011C048	MCAN7_TX	0	O	1.8 V/3.3 V	Off / Off / Off	Off / Off / Off	7	PU/PD	VDDSHV2	Yes	LVCMOS	Yes
		MCASP0_AXR2	1	IO									
		VOUT0_DATA11	2	O									
		HYP1_RXFLCLK	3	O									
		GPMC0_ADVn_ALE	6	O									
		GPIO0_18	7	IO									
		EQEP2_A	9	I									
		TRC_DATA10	10	O									
		UART4_CTSn	11	I									
		GPMC0_WPn	12	O									
UART9_CTSn	13	I											

**ADVANCE INFORMATION**

**表 6-1. Pin Attributes (ALY Package) (continued)**

Ball Num [1]	Ball Name [2] PADCFG Register [15] PADCFG Address [16]	Signal Name [3]	Mux Mode [4]	Signal Type [5]	I/O Voltage [6]	Ball State DURING Reset (RX/TX/PULL) [7]	Ball State AFTER Reset (RX/TX/PULL) [8]	Mux Mode AFTER Reset [9]	Pull Type [10]	Power [11]	Hys [12]	Voltage Buffer Type [13]	IO RET [14]
AJ38	MCASP0_AXR3 PADCFG: PADCONFIG_31 0x0011C07C	MCAN3_TX	0	O	1.8 V/3.3 V	Off / Off / Off	Off / Off / Off	7	PU/PD	VDDSHV2	Yes	LVCMOS	Yes
		MCASP0_AXR3	1	IO									
		VOUT0_DATA2	2	O									
		GPMC0_BE1n	6	O									
		GPIO0_31	7	IO									
		SPI5_CLK	8	IO									
		EHRPWM_TZn_IN0	9	I									
		TRC_DATA7	10	O									
		UART3_CTSn	11	I									
		SPI3_CS1	12	IO									
		SPI7_D1	13	IO									
AK34	MCASP0_AXR4 PADCFG: PADCONFIG_32 0x0011C080	MCAN3_RX	0	I	1.8 V/3.3 V	Off / Off / Off	Off / Off / Off	7	PU/PD	VDDSHV2	Yes	LVCMOS	Yes
		MCASP0_AXR4	1	IO									
		VOUT0_HSYNC	2	O									
		HYP1_TXPMDAT	3	O									
		VOUT0_VP0_HSYNC	4	O									
		VOUT0_VP2_HSYNC	5	O									
		GPMC0_OEn_REn	6	O									
		GPIO0_32	7	IO									
		SPI6_CS2	8	IO									
		EHRPWM5_B	9	IO									
		TRC_DATA18	10	O									
		I2C4_SDA	13	IOD									
		AG38	MCASP0_AXR5 PADCFG: PADCONFIG_33 0x0011C084	MCAN4_TX									
MCASP0_AXR5	1			IO									
VOUT0_DE	2			O									
MCASP1_ACLKR	3			IO									
VOUT0_VP0_DE	4			O									
VOUT0_VP2_DE	5			O									
GPMC0_CSn0	6			O									
GPIO0_33	7			IO									
SPI6_CS3	8			IO									
EHRPWM5_A	9			IO									
TRC_DATA19	10			O									
I2C4_SCL	13			IOD									

**ADVANCE INFORMATION**

**表 6-1. Pin Attributes (ALY Package) (continued)**

Ball Num [1]	Ball Name [2] PADCFG Register [15] PADCFG Address [16]	Signal Name [3]	Mux Mode [4]	Signal Type [5]	I/O Voltage [6]	Ball State DURING Reset (RX/TX/PULL) [7]	Ball State AFTER Reset (RX/TX/PULL) [8]	Mux Mode AFTER Reset [9]	Pull Type [10]	Power [11]	Hys [12]	Voltage Buffer Type [13]	IO RET [14]
AF36	MCASP0_AXR6 PADCFG: PADCONFIG_34 0x0011C088	MCAN4_RX	0	I	1.8 V/3.3 V	Off / Off / Off	Off / Off / Off	7	PU/PD	VDDSHV2	Yes	LVCMOS	Yes
		MCASP0_AXR6	1	IO									
		VOU0_VSYNC	2	O									
		MCASP1_AFSR	3	IO									
		VOU0_VP0_VSYNC	4	O									
		VOU0_VP2_VSYNC	5	O									
		GPMC0_CLKOUT	6	O									
		GPIO0_34	7	IO									
		SPI3_CS2	8	IO									
		EHRPWM_TZn_IN4	9	I									
		TRC_DATA20	10	O									
		SPI5_D1	11	IO									
		GPMC0_FCLK_MUX	12	O									
AE35	MCASP0_AXR7 PADCFG: PADCONFIG_35 0x0011C08C	MCAN5_TX	0	O	1.8 V/3.3 V	Off / Off / Off	Off / Off / Off	7	PU/PD	VDDSHV2	Yes	LVCMOS	Yes
		MCASP0_AXR7	1	IO									
		MCASP4_ACLKR	3	IO									
		GPMC0_A0	5	OZ									
		RGMI1_TD0	6	O									
		GPIO0_35	7	IO									
		GPMC0_A14	8	OZ									
		EHRPWM3_A	9	IO									
		UART4_RXD	11	I									
		GPMC0_CS2	12	O									
USB0_DRVVBUS	14	O											
AC35	MCASP0_AXR8 PADCFG: PADCONFIG_36 0x0011C090	MCAN5_RX	0	I	1.8 V/3.3 V	Off / Off / Off	Off / Off / Off	7	PU/PD	VDDSHV2	Yes	LVCMOS	Yes
		MCASP0_AXR8	1	IO									
		MCASP4_AFSR	3	IO									
		GPMC0_A1	5	OZ									
		RGMI1_TD1	6	O									
		GPIO0_36	7	IO									
		RMII1_RXD0	8	I									
		EHRPWM_TZn_IN3	9	I									
UART4_TXD	11	O											

**ADVANCE INFORMATION**

**表 6-1. Pin Attributes (ALY Package) (continued)**

Ball Num [1]	Ball Name [2] PADCFG Register [15] PADCFG Address [16]	Signal Name [3]	Mux Mode [4]	Signal Type [5]	I/O Voltage [6]	Ball State DURING Reset (RX/TX/PULL) [7]	Ball State AFTER Reset (RX/TX/PULL) [8]	Mux Mode AFTER Reset [9]	Pull Type [10]	Power [11]	Hys [12]	Voltage Buffer Type [13]	IO RET [14]
AG35	MCASP0_AXR9 PADCFG: PADCONFIG_37 0x0011C094	MCAN6_TX	0	O	1.8 V/3.3 V	Off / Off / Off	Off / Off / Off	7	PU/PD	VDDSHV2	Yes	LVC MOS	Yes
		MCASP0_AXR9	1	IO									
		MCASP4_AXR4	2	IO									
		GPMC0_A2	5	OZ									
		RGMI1_TD2	6	O									
		GPIO0_37	7	IO									
		RMII1_RXD1	8	I									
		EHRPWM3_SYNCO	9	O									
		UART4_CTSn	11	I									
AH36	MCASP0_AXR10 PADCFG: PADCONFIG_38 0x0011C098	MCAN6_RX	0	I	1.8 V/3.3 V	Off / Off / Off	Off / Off / Off	7	PU/PD	VDDSHV2	Yes	LVC MOS	Yes
		MCASP0_AXR10	1	IO									
		GPMC0_A3	5	OZ									
		RGMI1_TD3	6	O									
		GPIO0_38	7	IO									
		RMII1_CRS_DV	8	I									
		EHRPWM3_SYNCI	9	I									
		UART4_RTSn	11	O									
AF35	MCASP0_AXR11 PADCFG: PADCONFIG_39 0x0011C09C	MCAN7_TX	0	O	1.8 V/3.3 V	Off / Off / Off	Off / Off / Off	7	PU/PD	VDDSHV2	Yes	LVC MOS	Yes
		MCASP0_AXR11	1	IO									
		DSS_FSYNC2	4	O									
		GPMC0_A4	5	OZ									
		RGMI1_TX_CTL	6	O									
		GPIO0_39	7	IO									
		RMII1_RX_ER	8	I									
		EHRPWM3_B	9	IO									
		SPI2_CS1	10	IO									
		UART5_RXD	11	I									

**表 6-1. Pin Attributes (ALY Package) (continued)**

Ball Num [1]	Ball Name [2] PADCFG Register [15] PADCFG Address [16]	Signal Name [3]	Mux Mode [4]	Signal Type [5]	I/O Voltage [6]	Ball State DURING Reset (RX/TX/PULL) [7]	Ball State AFTER Reset (RX/TX/PULL) [8]	Mux Mode AFTER Reset [9]	Pull Type [10]	Power [11]	Hys [12]	Voltage Buffer Type [13]	IO RET [14]
AD34	MCASP0_AXR12 PADCFG: PADCONFIG_40 0x0011C0A0	MCAN7_RX	0	I	1.8 V/3.3 V	Off / Off / Off	Off / Off / Off	7	PU/PD	VDDSHV2	Yes	LVCMOS	Yes
		MCASP0_AXR12	1	IO									
		MCASP2_ACLKR	3	IO									
		DSS_FSYNC3	4	O									
		GPMC0_A5	5	OZ									
		RGMI1_RD1	6	I									
		GPIO0_40	7	IO									
		RMII1_TXD0	8	O									
		EHRPWM_SOCB	9	O									
		SPI2_CLK	10	IO									
UART5_TXD	11	O											
AJ36	MCASP0_AXR13 PADCFG: PADCONFIG_41 0x0011C0A4	MCAN8_TX	0	O	1.8 V/3.3 V	Off / Off / Off	Off / Off / Off	7	PU/PD	VDDSHV2	Yes	LVCMOS	Yes
		MCASP0_AXR13	1	IO									
		MCASP2_AFSR	3	IO									
		GPMC0_A6	5	OZ									
		RGMI1_RD2	6	I									
		GPIO0_41	7	IO									
		RMII_REF_CLK	8	I									
		EHRPWM4_A	9	IO									
		SPI2_CS0	10	IO									
		UART5_CTSn	11	I									
UART7_RXD	13	I											
AF34	MCASP0_AXR14 PADCFG: PADCONFIG_42 0x0011C0A8	MCAN8_RX	0	I	1.8 V/3.3 V	Off / Off / Off	Off / Off / Off	7	PU/PD	VDDSHV2	Yes	LVCMOS	Yes
		MCASP0_AXR14	1	IO									
		MCASP2_AXR4	2	IO									
		MCASP0_ACLKR	3	IO									
		GPMC0_A7	5	OZ									
		RGMI1_RD3	6	I									
		GPIO0_42	7	IO									
		CLKOUT	8	IO									
		EQEP0_A	9	I									
		SPI2_D0	10	IO									
UART5_RTSn	11	O											
UART7_TXD	13	O											

**ADVANCE INFORMATION**

**表 6-1. Pin Attributes (ALY Package) (continued)**

Ball Num [1]	Ball Name [2] PADCFG Register [15] PADCFG Address [16]	Signal Name [3]	Mux Mode [4]	Signal Type [5]	I/O Voltage [6]	Ball State DURING Reset (RX/TX/PULL) [7]	Ball State AFTER Reset (RX/TX/PULL) [8]	Mux Mode AFTER Reset [9]	Pull Type [10]	Power [11]	Hys [12]	Voltage Buffer Type [13]	IO RET [14]
AE34	MCASP0_AXR15 PADCFG: PADCONFIG_43 0x0011C0AC	MCAN9_TX	0	O	1.8 V/3.3 V	Off / Off / Off	Off / Off / Off	7	PU/PD	VDDSHV2	Yes	LVCMOS	Yes
		MCASP0_AXR15	1	IO									
		MCASP0_AFSR	3	IO									
		GPMC0_A8	5	OZ									
		RGMII1_RX_CTL	6	I									
		GPIO0_43	7	IO									
		RMII1_TX_EN	8	O									
		EQEP0_B	9	I									
		SPI2_D1	10	IO									
		UART8_RXD	11	I									
		I2C1_SCL	13	IOD									
AD38	MCASP1_AXR0 PADCFG: PADCONFIG_48 0x0011C0C0	MCAN11_RX	0	I	1.8 V/3.3 V	Off / Off / Off	Off / Off / Off	7	PU/PD	VDDSHV2	Yes	LVCMOS	Yes
		MCASP1_AXR0	1	IO									
		GPMC0_A13	5	OZ									
		MDIO0_MDC	6	O									
		GPIO0_48	7	IO									
		SPI3_CLK	8	IO									
		EQEP1_S	9	IO									
		UART0_TXD	11	O									
		GPMC0_WAIT3	12	I									
		SYNC2_OUT	14	O									
		AC32	MCASP1_AXR1 PADCFG: PADCONFIG_19 0x0011C04C	MCAN7_RX									
MCASP1_AXR1	1			IO									
VOUT0_DATA10	2			O									
HYP1_RXPMCLK	3			I									
GPMC0_AD8	6			IO									
GPIO0_19	7			IO									
SPI3_D0	8			IO									
EHRPWM_TZn_IN1	9			I									
TRC_DATA8	10			O									
UART0_CTSn	11			I									
UART9_RXD	12			I									
I2C2_SCL	13	IOD											

**ADVANCE INFORMATION**

**表 6-1. Pin Attributes (ALY Package) (continued)**

Ball Num [1]	Ball Name [2] PADCFG Register [15] PADCFG Address [16]	Signal Name [3]	Mux Mode [4]	Signal Type [5]	I/O Voltage [6]	Ball State DURING Reset (RX/TX/PULL) [7]	Ball State AFTER Reset (RX/TX/PULL) [8]	Mux Mode AFTER Reset [9]	Pull Type [10]	Power [11]	Hys [12]	Voltage Buffer Type [13]	IO RET [14]
AC37	MCASP1_AXR2 PADCFG: PADCONFIG_20 0x0011C050	MCAN8_TX	0	O	1.8 V/3.3 V	Off / Off / Off	Off / Off / Off	7	PU/PD	VDDSHV2	Yes	LVCMOS	Yes
		MCASP1_AXR2	1	IO									
		VOU0_DATA9	2	O									
		HYP1_RXPMDAT	3	I									
		VOU0_DATA21	5	O									
		GPMC0_AD9	6	IO									
		GPIO0_20	7	IO									
		SPI3_D1	8	IO									
		EQEP2_B	9	I									
		TRC_DATA6	10	O									
		UART0_RTSn	11	O									
		UART9_TXD	12	O									
		I2C2_SDA	13	IOD									
AL33	MCASP1_AXR3 PADCFG: PADCONFIG_44 0x0011C0B0	MCAN9_RX	0	I	1.8 V/3.3 V	Off / Off / Off	Off / Off / Off	7	PU/PD	VDDSHV2	Yes	LVCMOS	Yes
		MCASP1_AXR3	1	IO									
		PCIE2_CLKREQn	4	IO									
		GPMC0_A9	5	OZ									
		RGMI1_RXC	6	I									
		GPIO0_44	7	IO									
		RMII1_TXD1	8	O									
		EQEP1_A	9	I									
		UART8_TXD	11	O									
		I2C1_SDA	13	IOD									
AL34	MCASP1_AXR4 PADCFG: PADCONFIG_45 0x0011C0B4	MCAN10_TX	0	O	1.8 V/3.3 V	Off / Off / Off	Off / Off / Off	7	PU/PD	VDDSHV2	Yes	LVCMOS	Yes
		MCASP1_AXR4	1	IO									
		PCIE3_CLKREQn	4	IO									
		GPMC0_A10	5	OZ									
		RGMI1_TXC	6	O									
		GPIO0_45	7	IO									
		EQEP1_B	9	I									
		UART4_RXD	11	I									



**表 6-1. Pin Attributes (ALY Package) (continued)**

Ball Num [1]	Ball Name [2] PADCFG Register [15] PADCFG Address [16]	Signal Name [3]	Mux Mode [4]	Signal Type [5]	I/O Voltage [6]	Ball State DURING Reset (RX/TX/PULL) [7]	Ball State AFTER Reset (RX/TX/PULL) [8]	Mux Mode AFTER Reset [9]	Pull Type [10]	Power [11]	Hys [12]	Voltage Buffer Type [13]	IO RET [14]
AC36	MCASP2_AXR0 PADCFG: PADCONFIG_23 0x0011C05C	MCAN9_RX	0	I	1.8 V/3.3 V	Off / Off / Off	Off / Off / Off	7	PU/PD	VDDSHV2	Yes	LVC MOS	Yes
		MCASP2_AXR0	1	IO									
		VOUT0_DATA6	2	O									
		HYP0_RXPMCLK	3	I									
		MDIO1_MDIO	4	IO									
		GPMC0_AD12	6	IO									
		GPIO0_23	7	IO									
		EQEP2_I	9	IO									
		TRC_DATA15	10	O									
		UART1_CTSn	11	I									
		UART6_RXD	12	I									
AE36	MCASP2_AXR1 PADCFG: PADCONFIG_24 0x0011C060	MCAN17_RX	0	I	1.8 V/3.3 V	Off / Off / Off	Off / Off / Off	7	PU/PD	VDDSHV2	Yes	LVC MOS	Yes
		MCASP2_AXR1	1	IO									
		VOUT0_DATA5	2	O									
		HYP0_RXPMDAT	3	I									
		GPMC0_AD13	6	IO									
		GPIO0_24	7	IO									
		EHRPWM1_A	9	IO									
		TRC_DATA13	10	O									
		UART1_RTSn	11	O									
		UART6_TXD	12	O									
		I2C3_SDA	13	IOD									
U35	MCU_ADC0_REFN	MCU_ADC0_REFN		A	1.8 V					VDDA_ADC0		ADC12B	No
R35	MCU_ADC0_REFP	MCU_ADC0_REFP		A	1.8 V					VDDA_ADC0		ADC12B	No
W35	MCU_ADC1_REFN	MCU_ADC1_REFN		A	1.8 V					VDDA_ADC1		ADC12B	No
AA35	MCU_ADC1_REFP	MCU_ADC1_REFP		A	1.8 V					VDDA_ADC1		ADC12B	No
P36	MCU_ADC0_AIN0 PADCFG: WKUP_PADCONFIG_77 0x4301C134	MCU_ADC0_AIN0	0	A	1.8 V			0		VDDA_ADC0		ADC12B	No
		WKUP_GPIO0_71	7	I									
V36	MCU_ADC0_AIN1 PADCFG: WKUP_PADCONFIG_78 0x4301C138	MCU_ADC0_AIN1	0	A	1.8 V			0		VDDA_ADC0		ADC12B	No
		WKUP_GPIO0_72	7	I									
T34	MCU_ADC0_AIN2 PADCFG: WKUP_PADCONFIG_79 0x4301C13C	MCU_ADC0_AIN2	0	A	1.8 V			0		VDDA_ADC0		ADC12B	No
		WKUP_GPIO0_73	7	I									

**ADVANCE INFORMATION**

**表 6-1. Pin Attributes (ALY Package) (continued)**

Ball Num [1]	Ball Name [2] PADCFG Register [15] PADCFG Address [16]	Signal Name [3]	Mux Mode [4]	Signal Type [5]	I/O Voltage [6]	Ball State DURING Reset (RX/TX/PULL) [7]	Ball State AFTER Reset (RX/TX/PULL) [8]	Mux Mode AFTER Reset [9]	Pull Type [10]	Power [11]	Hys [12]	Voltage Buffer Type [13]	IO RET [14]
T36	MCU_ADC0_AIN3 PADCFG: WKUP_PADCONFIG_80 0x4301C140	MCU_ADC0_AIN3	0	A	1.8 V			0		VDDA_ADC0		ADC12B	No
		WKUP_GPIO0_74	7	I									
P34	MCU_ADC0_AIN4 PADCFG: WKUP_PADCONFIG_81 0x4301C144	MCU_ADC0_AIN4	0	A	1.8 V			0		VDDA_ADC0		ADC12B	No
		WKUP_GPIO0_75	7	I									
R37	MCU_ADC0_AIN5 PADCFG: WKUP_PADCONFIG_82 0x4301C148	MCU_ADC0_AIN5	0	A	1.8 V			0		VDDA_ADC0		ADC12B	No
		WKUP_GPIO0_76	7	I									
R33	MCU_ADC0_AIN6 PADCFG: WKUP_PADCONFIG_83 0x4301C14C	MCU_ADC0_AIN6	0	A	1.8 V			0		VDDA_ADC0		ADC12B	No
		WKUP_GPIO0_77	7	I									
V38	MCU_ADC0_AIN7 PADCFG: WKUP_PADCONFIG_84 0x4301C150	MCU_ADC0_AIN7	0	A	1.8 V			0		VDDA_ADC0		ADC12B	No
		WKUP_GPIO0_78	7	I									
Y38	MCU_ADC1_AIN0 PADCFG: WKUP_PADCONFIG_85 0x4301C154	MCU_ADC1_AIN0	0	A	1.8 V			0		VDDA_ADC1		ADC12B	No
		WKUP_GPIO0_79	7	I									
Y34	MCU_ADC1_AIN1 PADCFG: WKUP_PADCONFIG_86 0x4301C158	MCU_ADC1_AIN1	0	A	1.8 V			0		VDDA_ADC1		ADC12B	No
		WKUP_GPIO0_80	7	I									
V34	MCU_ADC1_AIN2 PADCFG: WKUP_PADCONFIG_87 0x4301C15C	MCU_ADC1_AIN2	0	A	1.8 V			0		VDDA_ADC1		ADC12B	No
		WKUP_GPIO0_81	7	I									
W37	MCU_ADC1_AIN3 PADCFG: WKUP_PADCONFIG_88 0x4301C160	MCU_ADC1_AIN3	0	A	1.8 V			0		VDDA_ADC1		ADC12B	No
		WKUP_GPIO0_82	7	I									
AA37	MCU_ADC1_AIN4 PADCFG: WKUP_PADCONFIG_89 0x4301C164	MCU_ADC1_AIN4	0	A	1.8 V			0		VDDA_ADC1		ADC12B	No
		WKUP_GPIO0_83	7	I									
W33	MCU_ADC1_AIN5 PADCFG: WKUP_PADCONFIG_90 0x4301C168	MCU_ADC1_AIN5	0	A	1.8 V			0		VDDA_ADC1		ADC12B	No
		WKUP_GPIO0_84	7	I									

ADVANCE INFORMATION

表 6-1. Pin Attributes (ALY Package) (continued)

Ball Num [1]	Ball Name [2] PADCFG Register [15] PADCFG Address [16]	Signal Name [3]	Mux Mode [4]	Signal Type [5]	I/O Voltage [6]	Ball State DURING Reset (RX/TX/PULL) [7]	Ball State AFTER Reset (RX/TX/PULL) [8]	Mux Mode AFTER Reset [9]	Pull Type [10]	Power [11]	Hys [12]	Voltage Buffer Type [13]	IO RET [14]
U33	MCU_ADC1_AIN6 PADCFG: WKUP_PADCONFIG_91 0x4301C16C	MCU_ADC1_AIN6	0	A	1.8 V			0		VDDA_ADC1		ADC12B	No
		WKUP_GPIO0_85	7	I									
Y36	MCU_ADC1_AIN7 PADCFG: WKUP_PADCONFIG_92 0x4301C170	MCU_ADC1_AIN7	0	A	1.8 V			0		VDDA_ADC1		ADC12B	No
		WKUP_GPIO0_86	7	I									
M35	MCU_I2C0_SCL PADCFG: WKUP_PADCONFIG_66 0x4301C108	MCU_I2C0_SCL	0	IOD	1.8 V/3.3 V	Off / Off / Off	On / SS / Off	0		VDDSHV0_MCU	Yes	I2C OPEN DRAIN	Yes
		WKUP_GPIO0_65	7	IO									
G34	MCU_I2C0_SDA PADCFG: WKUP_PADCONFIG_67 0x4301C10C	MCU_I2C0_SDA	0	IOD	1.8 V/3.3 V	Off / Off / Off	On / SS / Off	0		VDDSHV0_MCU	Yes	I2C OPEN DRAIN	Yes
		WKUP_GPIO0_87	7	IO									
F38	MCU_MCAN0_RX PADCFG: WKUP_PADCONFIG_47 0x4301C0BC	MCU_MCAN0_RX	0	I	1.8 V/3.3 V	Off / Off / Off	Off / Off / Off	7	PU/PD	VDDSHV0_MCU	Yes	LVCMOS	Yes
		WKUP_GPIO0_61	7	IO									
K33	MCU_MCAN0_TX PADCFG: WKUP_PADCONFIG_46 0x4301C0B8	MCU_MCAN0_TX	0	O	1.8 V/3.3 V	Off / Off / Off	Off / Off / Off	7	PU/PD	VDDSHV0_MCU	Yes	LVCMOS	Yes
		WKUP_GPIO0_60	7	IO									
A36	MCU_MDIO0_MDC PADCFG: WKUP_PADCONFIG_39 0x4301C09C	MCU_MDIO0_MDC	0	O	1.8 V/3.3 V	Off / Off / Off	Off / Off / Off	7	PU/PD	VDDSHV2_MCU	Yes	LVCMOS	No
		WKUP_GPIO0_53	7	IO									
B35	MCU_MDIO0_MDIO PADCFG: WKUP_PADCONFIG_38 0x4301C098	MCU_MDIO0_MDIO	0	IO	1.8 V/3.3 V	Off / Off / Off	Off / Off / Off	7	PU/PD	VDDSHV2_MCU	Yes	LVCMOS	No
		WKUP_GPIO0_52	7	IO									
E32	MCU_OSPI0_CLK PADCFG: WKUP_PADCONFIG_0 0x4301C000	MCU_OSPI0_CLK	0	O	1.8 V/3.3 V	Off / Off / Off	Off / Off / Off	7	PU/PD	VDDSHV1_MCU	Yes	LVCMOS	No
		MCU_HYPERBUS0_CK	1	O									
		WKUP_GPIO0_16	7	IO									
C34	MCU_OSPI0_DQS PADCFG: WKUP_PADCONFIG_2 0x4301C008	MCU_OSPI0_DQS	0	I	1.8 V/3.3 V	Off / Off / Off	Off / Off / Off	7	PU/PD	VDDSHV1_MCU	Yes	LVCMOS	No
		MCU_HYPERBUS0_RWDS	1	IO									
		WKUP_GPIO0_18	7	IO									
D32	MCU_OSPI0_LBCLKO PADCFG: WKUP_PADCONFIG_1 0x4301C004	MCU_OSPI0_LBCLKO	0	IO	1.8 V/3.3 V	Off / Off / Off	On / Off / Off	7	PU/PD	VDDSHV1_MCU	Yes	LVCMOS	No
		MCU_HYPERBUS0_CK <sub>n</sub>	1	O									
		WKUP_GPIO0_17	7	IO									

**表 6-1. Pin Attributes (ALY Package) (continued)**

Ball Num [1]	Ball Name [2] PADCFG Register [15] PADCFG Address [16]	Signal Name [3]	Mux Mode [4]	Signal Type [5]	I/O Voltage [6]	Ball State DURING Reset (RX/TX/PULL) [7]	Ball State AFTER Reset (RX/TX/PULL) [8]	Mux Mode AFTER Reset [9]	Pull Type [10]	Power [11]	Hys [12]	Voltage Buffer Type [13]	IO RET [14]
F32	MCU_OSP11_CLK PADCFG: WKUP_PADCONFIG_16 0x4301C040	MCU_OSP11_CLK	0	O	1.8 V/3.3 V	Off / Off / Off	Off / Off / Off	7	PU/PD	VDDSHV1_MCU	Yes	LVCMOS	No
		WKUP_GPIO0_31	7	IO									
F31	MCU_OSP11_DQS PADCFG: WKUP_PADCONFIG_18 0x4301C048	MCU_OSP11_DQS	0	I	1.8 V/3.3 V	Off / Off / Off	Off / Off / Off	7	PU/PD	VDDSHV1_MCU	Yes	LVCMOS	No
		MCU_OSPI0_CSn3	1	O									
		MCU_HYPERBUS0_INTn	2	I									
		MCU_OSPI0_ECC_FAIL	6	I									
C31	MCU_OSP11_LBCLKO PADCFG: WKUP_PADCONFIG_17 0x4301C044	MCU_OSP11_LBCLKO	0	IO	1.8 V/3.3 V	Off / Off / Off	On / Off / Off	7	PU/PD	VDDSHV1_MCU	Yes	LVCMOS	No
		MCU_OSPI0_CSn2	1	O									
		MCU_HYPERBUS0_RESETOn	2	I									
		MCU_OSPI0_RESET_OUT0	6	O									
A32	MCU_OSPI0_CSn0 PADCFG: WKUP_PADCONFIG_11 0x4301C02C	MCU_OSPI0_CSn0	0	O	1.8 V/3.3 V	Off / Off / Off	Off / Off / Off	7	PU/PD	VDDSHV1_MCU	Yes	LVCMOS	No
		MCU_HYPERBUS0_CSn0	1	O									
		WKUP_GPIO0_27	7	IO									
A33	MCU_OSPI0_CSn1 PADCFG: WKUP_PADCONFIG_12 0x4301C030	MCU_OSPI0_CSn1	0	O	1.8 V/3.3 V	Off / Off / Off	Off / Off / Off	7	PU/PD	VDDSHV1_MCU	Yes	LVCMOS	No
		MCU_HYPERBUS0_RESETOn	1	O									
		WKUP_GPIO0_28	7	IO									
B34	MCU_OSPI0_CSn2 PADCFG: WKUP_PADCONFIG_14 0x4301C038	MCU_OSPI0_CSn2	0	O	1.8 V/3.3 V	Off / Off / Off	Off / Off / Off	7	PU/PD	VDDSHV1_MCU	Yes	LVCMOS	No
		MCU_OSPI0_CSn2	1	O									
		MCU_HYPERBUS0_RESETOn	2	I									
		MCU_HYPERBUS0_WPn	3	O									
		MCU_HYPERBUS0_CSn1	4	O									
		MCU_OSPI0_RESET_OUT0	6	O									
WKUP_GPIO0_29	7	IO											
C32	MCU_OSPI0_CSn3 PADCFG: WKUP_PADCONFIG_15 0x4301C03C	MCU_OSPI0_CSn3	0	O	1.8 V/3.3 V	Off / Off / Off	Off / Off / Off	7	PU/PD	VDDSHV1_MCU	Yes	LVCMOS	No
		MCU_OSPI0_CSn3	1	O									
		MCU_HYPERBUS0_INTn	2	I									
		MCU_HYPERBUS0_WPn	3	O									
		MCU_OSPI0_RESET_OUT1	5	O									
		MCU_OSPI0_ECC_FAIL	6	I									
WKUP_GPIO0_30	7	IO											

ADVANCE INFORMATION

**表 6-1. Pin Attributes (ALY Package) (continued)**

Ball Num [1]	Ball Name [2] PADCFG Register [15] PADCFG Address [16]	Signal Name [3]	Mux Mode [4]	Signal Type [5]	I/O Voltage [6]	Ball State DURING Reset (RX/TX/PULL) [7]	Ball State AFTER Reset (RX/TX/PULL) [8]	Mux Mode AFTER Reset [9]	Pull Type [10]	Power [11]	Hys [12]	Voltage Buffer Type [13]	IO RET [14]
B33	MCU_OSPI0_D0 PADCFG: WKUP_PADCONFIG_3 0x4301C00C	MCU_OSPI0_D0	0	IO	1.8 V/3.3 V	On / Off / Off	On / Off / Off	7	PU/PD	VDDSHV1_M CU	Yes	LVC MOS	No
		MCU_HYPERBUS0_DQ0	1	IO									
		WKUP_GPIO0_19	7	IO									
		BOOTMODE00	BOOTS TRAP	I									
B32	MCU_OSPI0_D1 PADCFG: WKUP_PADCONFIG_4 0x4301C010	MCU_OSPI0_D1	0	IO	1.8 V/3.3 V	On / Off / Off	On / Off / Off	7	PU/PD	VDDSHV1_M CU	Yes	LVC MOS	No
		MCU_HYPERBUS0_DQ1	1	IO									
		WKUP_GPIO0_20	7	IO									
		BOOTMODE01	BOOTS TRAP	I									
C33	MCU_OSPI0_D2 PADCFG: WKUP_PADCONFIG_5 0x4301C014	MCU_OSPI0_D2	0	IO	1.8 V/3.3 V	Off / Off / Off	Off / Off / Off	7	PU/PD	VDDSHV1_M CU	Yes	LVC MOS	No
		MCU_HYPERBUS0_DQ2	1	IO									
		WKUP_GPIO0_21	7	IO									
C35	MCU_OSPI0_D3 PADCFG: WKUP_PADCONFIG_6 0x4301C018	MCU_OSPI0_D3	0	IO	1.8 V/3.3 V	Off / Off / Off	Off / Off / Off	7	PU/PD	VDDSHV1_M CU	Yes	LVC MOS	No
		MCU_HYPERBUS0_DQ3	1	IO									
		WKUP_GPIO0_22	7	IO									
D33	MCU_OSPI0_D4 PADCFG: WKUP_PADCONFIG_7 0x4301C01C	MCU_OSPI0_D4	0	IO	1.8 V/3.3 V	On / Off / Off	On / Off / Off	7	PU/PD	VDDSHV1_M CU	Yes	LVC MOS	No
		MCU_HYPERBUS0_DQ4	1	IO									
		WKUP_GPIO0_23	7	IO									
		BOOTMODE02	BOOTS TRAP	I									
D34	MCU_OSPI0_D5 PADCFG: WKUP_PADCONFIG_8 0x4301C020	MCU_OSPI0_D5	0	IO	1.8 V/3.3 V	On / Off / Off	On / Off / Off	7	PU/PD	VDDSHV1_M CU	Yes	LVC MOS	No
		MCU_HYPERBUS0_DQ5	1	IO									
		WKUP_GPIO0_24	7	IO									
		BOOTMODE03	BOOTS TRAP	I									
E34	MCU_OSPI0_D6 PADCFG: WKUP_PADCONFIG_9 0x4301C024	MCU_OSPI0_D6	0	IO	1.8 V/3.3 V	Off / Off / Off	Off / Off / Off	7	PU/PD	VDDSHV1_M CU	Yes	LVC MOS	No
		MCU_HYPERBUS0_DQ6	1	IO									
		WKUP_GPIO0_25	7	IO									
E33	MCU_OSPI0_D7 PADCFG: WKUP_PADCONFIG_10 0x4301C028	MCU_OSPI0_D7	0	IO	1.8 V/3.3 V	Off / Off / Off	Off / Off / Off	7	PU/PD	VDDSHV1_M CU	Yes	LVC MOS	No
		MCU_HYPERBUS0_DQ7	1	IO									
		WKUP_GPIO0_26	7	IO									
G32	MCU_OSPI1_CSn0 PADCFG: WKUP_PADCONFIG_23 0x4301C05C	MCU_OSPI1_CSn0	0	O	1.8 V/3.3 V	Off / Off / Off	Off / Off / Off	7	PU/PD	VDDSHV1_M CU	Yes	LVC MOS	No
		WKUP_GPIO0_38	7	IO									

**表 6-1. Pin Attributes (ALY Package) (continued)**

Ball Num [1]	Ball Name [2] PADCFG Register [15] PADCFG Address [16]	Signal Name [3]	Mux Mode [4]	Signal Type [5]	I/O Voltage [6]	Ball State DURING Reset (RX/TX/PULL) [7]	Ball State AFTER Reset (RX/TX/PULL) [8]	Mux Mode AFTER Reset [9]	Pull Type [10]	Power [11]	Hys [12]	Voltage Buffer Type [13]	IO RET [14]
G33	MCU_OSPI1_CSn1 PADCFG: WKUP_PADCONFIG_24 0x4301C060	MCU_OSPI1_CSn1	0	O	1.8 V/3.3 V	Off / Off / Off	Off / Off / Off	7	PU/PD	VDDSHV1_MCU	Yes	LVC MOS	No
		MCU_HYPERBUS0_WPn	1	O									
		MCU_TIMER_I00	2	IO									
		MCU_HYPERBUS0_CSn1	3	O									
		MCU_UART0_RTSn	4	O									
		MCU_SPI0_CS2	5	IO									
		MCU_OSPI0_RESET_OUT1	6	O									
WKUP_GPIO0_39	7	IO											
E35	MCU_OSPI1_D0 PADCFG: WKUP_PADCONFIG_19 0x4301C04C	MCU_OSPI1_D0	0	IO	1.8 V/3.3 V	Off / Off / Off	Off / Off / Off	7	PU/PD	VDDSHV1_MCU	Yes	LVC MOS	No
		WKUP_GPIO0_34	7	IO									
D31	MCU_OSPI1_D1 PADCFG: WKUP_PADCONFIG_20 0x4301C050	MCU_OSPI1_D1	0	IO	1.8 V/3.3 V	Off / Off / Off	Off / Off / Off	7	PU/PD	VDDSHV1_MCU	Yes	LVC MOS	No
		MCU_UART0_RXD	4	I									
		MCU_SPI1_CS1	5	IO									
		WKUP_GPIO0_35	7	IO									
G31	MCU_OSPI1_D2 PADCFG: WKUP_PADCONFIG_21 0x4301C054	MCU_OSPI1_D2	0	IO	1.8 V/3.3 V	Off / Off / Off	Off / Off / Off	7	PU/PD	VDDSHV1_MCU	Yes	LVC MOS	No
		MCU_UART0_TXD	4	O									
		MCU_SPI1_CS2	5	IO									
		WKUP_GPIO0_36	7	IO									
F33	MCU_OSPI1_D3 PADCFG: WKUP_PADCONFIG_22 0x4301C058	MCU_OSPI1_D3	0	IO	1.8 V/3.3 V	Off / Off / Off	Off / Off / Off	7	PU/PD	VDDSHV1_MCU	Yes	LVC MOS	No
		MCU_UART0_CTSn	4	I									
		MCU_SPI0_CS1	5	IO									
		WKUP_GPIO0_37	7	IO									
K32	MCU_PORz	MCU_PORz		I	1.8 V					VDDA_WKUP	Yes	FS_RESET	No
F36	MCU_RESETSTATz PADCFG: WKUP_PADCONFIG_71 0x4301C11C	MCU_RESETSTATz	0	O	1.8 V/3.3 V	Off / Low / Off	Off / SS / Off	0	PU/PD	VDDSHV0_MCU	Yes	LVC MOS	No
		WKUP_GPIO0_68	7	IO									
G36	MCU_RESETz PADCFG: WKUP_PADCONFIG_70 0x4301C118	MCU_RESETz	0	I	1.8 V/3.3 V	On / NA / Up	On / Off / Up	0	PU/PD	VDDSHV0_MCU	Yes	LVC MOS	No
B37	MCU_RGMII1_RXC PADCFG: WKUP_PADCONFIG_33 0x4301C084	MCU_RGMII1_RXC	0	I	1.8 V/3.3 V	Off / Off / Off	Off / Off / Off	7	PU/PD	VDDSHV2_MCU	Yes	LVC MOS	No
		MCU_RMII1_REF_CLK	1	I									
		WKUP_GPIO0_47	7	IO									
C37	MCU_RGMII1_RX_CTL PADCFG: WKUP_PADCONFIG_27 0x4301C06C	MCU_RGMII1_RX_CTL	0	I	1.8 V/3.3 V	Off / Off / Off	Off / Off / Off	7	PU/PD	VDDSHV2_MCU	Yes	LVC MOS	No
		MCU_RMII1_RX_ER	1	I									
		WKUP_GPIO0_41	7	IO									

表 6-1. Pin Attributes (ALY Package) (continued)

Ball Num [1]	Ball Name [2] PADCFG Register [15] PADCFG Address [16]	Signal Name [3]	Mux Mode [4]	Signal Type [5]	I/O Voltage [6]	Ball State DURING Reset (RX/TX/PULL) [7]	Ball State AFTER Reset (RX/TX/PULL) [8]	Mux Mode AFTER Reset [9]	Pull Type [10]	Power [11]	Hys [12]	Voltage Buffer Type [13]	IO RET [14]
E36	MCU_RGMII1_TXC PADCFG: WKUP_PADCONFIG_32 0x4301C080	MCU_RGMII1_TXC	0	O	1.8 V/3.3 V	Off / Off / Off	Off / Off / Off	7	PU/PD	VDDSHV2_M CU	Yes	LVCMOS	No
		MCU_RMII1_TX_EN	1	O									
		WKUP_GPIO0_46	7	IO									
C38	MCU_RGMII1_TX_CTL PADCFG: WKUP_PADCONFIG_26 0x4301C068	MCU_RGMII1_TX_CTL	0	O	1.8 V/3.3 V	Off / Off / Off	Off / Off / Off	7	PU/PD	VDDSHV2_M CU	Yes	LVCMOS	No
		MCU_RMII1_CRS_DV	1	I									
		WKUP_GPIO0_40	7	IO									
A35	MCU_RGMII1_RD0 PADCFG: WKUP_PADCONFIG_37 0x4301C094	MCU_RGMII1_RD0	0	I	1.8 V/3.3 V	Off / Off / Off	Off / Off / Off	7	PU/PD	VDDSHV2_M CU	Yes	LVCMOS	No
		MCU_RMII1_RXD0	1	I									
		WKUP_GPIO0_51	7	IO									
B36	MCU_RGMII1_RD1 PADCFG: WKUP_PADCONFIG_36 0x4301C090	MCU_RGMII1_RD1	0	I	1.8 V/3.3 V	Off / Off / Off	Off / Off / Off	7	PU/PD	VDDSHV2_M CU	Yes	LVCMOS	No
		MCU_RMII1_RXD1	1	I									
		WKUP_GPIO0_50	7	IO									
C36	MCU_RGMII1_RD2 PADCFG: WKUP_PADCONFIG_35 0x4301C08C	MCU_RGMII1_RD2	0	I	1.8 V/3.3 V	Off / Off / Off	Off / Off / Off	7	PU/PD	VDDSHV2_M CU	Yes	LVCMOS	No
		MCU_TIMER_IO5	1	IO									
		WKUP_GPIO0_62	7	IO									
D36	MCU_RGMII1_RD3 PADCFG: WKUP_PADCONFIG_34 0x4301C088	MCU_RGMII1_RD3	0	I	1.8 V/3.3 V	Off / Off / Off	Off / Off / Off	7	PU/PD	VDDSHV2_M CU	Yes	LVCMOS	No
		MCU_TIMER_IO4	1	IO									
		WKUP_GPIO0_48	7	IO									
D37	MCU_RGMII1_TD0 PADCFG: WKUP_PADCONFIG_31 0x4301C07C	MCU_RGMII1_TD0	0	O	1.8 V/3.3 V	Off / Off / Off	Off / Off / Off	7	PU/PD	VDDSHV2_M CU	Yes	LVCMOS	No
		MCU_RMII1_TXD0	1	O									
		WKUP_GPIO0_45	7	IO									
D38	MCU_RGMII1_TD1 PADCFG: WKUP_PADCONFIG_30 0x4301C078	MCU_RGMII1_TD1	0	O	1.8 V/3.3 V	Off / Off / Off	Off / Off / Off	7	PU/PD	VDDSHV2_M CU	Yes	LVCMOS	No
		MCU_RMII1_TXD1	1	O									
		WKUP_GPIO0_44	7	IO									
E37	MCU_RGMII1_TD2 PADCFG: WKUP_PADCONFIG_29 0x4301C074	MCU_RGMII1_TD2	0	O	1.8 V/3.3 V	Off / Off / Off	Off / Off / Off	7	PU/PD	VDDSHV2_M CU	Yes	LVCMOS	No
		MCU_TIMER_IO3	1	IO									
		MCU_ADC_EXT_TRIGGER1	3	I									
		WKUP_GPIO0_43	7	IO									
E38	MCU_RGMII1_TD3 PADCFG: WKUP_PADCONFIG_28 0x4301C070	MCU_RGMII1_TD3	0	O	1.8 V/3.3 V	Off / Off / Off	Off / Off / Off	7	PU/PD	VDDSHV2_M CU	Yes	LVCMOS	No
		MCU_TIMER_IO2	1	IO									
		MCU_ADC_EXT_TRIGGER0	3	I									
		WKUP_GPIO0_42	7	IO									
N36	MCU_SAFETY_ERRORn PADCFG: WKUP_PADCONFIG_69 0x4301C114	MCU_SAFETY_ERRORn	0	IO	1.8 V	Off / Off / Down	On / SS / Down	0	PU/PD	VDDA_WKUP	Yes	LVCMOS	No

**表 6-1. Pin Attributes (ALY Package) (continued)**

Ball Num [1]	Ball Name [2] PADCFG Register [15] PADCFG Address [16]	Signal Name [3]	Mux Mode [4]	Signal Type [5]	I/O Voltage [6]	Ball State DURING Reset (RX/TX/PULL) [7]	Ball State AFTER Reset (RX/TX/PULL) [8]	Mux Mode AFTER Reset [9]	Pull Type [10]	Power [11]	Hys [12]	Voltage Buffer Type [13]	IO RET [14]
G38	MCU_SPI0_CLK PADCFG: WKUP_PADCONFIG_40 0x4301C0A0	MCU_SPI0_CLK	0	IO	1.8 V/3.3 V	On / Off / Off	On / Off / Off	7	PU/PD	VDDSHV0_MCU	Yes	LVC MOS	Yes
		WKUP_GPIO0_54	7	IO									
		MCU_BOOTMODE00	BOOTS TRAP	I									
F37	MCU_SPI0_CS0 PADCFG: WKUP_PADCONFIG_43 0x4301C0AC	MCU_SPI0_CS0	0	IO	1.8 V/3.3 V	Off / Off / Off	Off / Off / Off	7	PU/PD	VDDSHV0_MCU	Yes	LVC MOS	Yes
		MCU_TIMER_IO1	4	IO									
		WKUP_GPIO0_70	7	IO									
H36	MCU_SPI0_D0 PADCFG: WKUP_PADCONFIG_41 0x4301C0A4	MCU_SPI0_D0	0	IO	1.8 V/3.3 V	On / Off / Off	On / Off / Off	7	PU/PD	VDDSHV0_MCU	Yes	LVC MOS	Yes
		WKUP_GPIO0_55	7	IO									
		MCU_BOOTMODE01	BOOTS TRAP	I									
J38	MCU_SPI0_D1 PADCFG: WKUP_PADCONFIG_42 0x4301C0A8	MCU_SPI0_D1	0	IO	1.8 V/3.3 V	On / Off / Off	On / Off / Off	7	PU/PD	VDDSHV0_MCU	Yes	LVC MOS	Yes
		MCU_TIMER_IO0	4	IO									
		WKUP_GPIO0_69	7	IO									
		MCU_BOOTMODE02	BOOTS TRAP	I									
AJ7	MMC0_CALPAD	MMC0_CALPAD		A	1.8 V				PU/PD	VDDS_MMC0		eMMC PHY	No
AK5	MMC0_CLK	MMC0_CLK		O	1.8 V				PU/PD	VDDS_MMC0		eMMC PHY	No
AL8	MMC0_CMD	MMC0_CMD		IO	1.8 V				PU/PD	VDDS_MMC0		eMMC PHY	No
AK4	MMC0_DS	MMC0_DS		IO	1.8 V				PU/PD	VDDS_MMC0		eMMC PHY	No
AB38	MMC1_CLK PADCFG: PADCONFIG_65 0x0011C104	MMC1_CLK	0	IO	1.8 V/3.3 V	Off / Off / Off	Off / Off / Off	7	PU/PD	VDDSHV5	Yes	SDIO	No
		UART8_RXD	1	I									
		TIMER_IO6	3	IO									
		EHRPWM2_B	4	IO									
		UART4_CTSn	5	I									
		EHRPWM5_A	6	IO									
		GPIO0_64	7	IO									
		SPI1_CLK	8	IO									
		UART0_RTSn	9	O									
		I2C6_SDA	10	IOD									
		MCAN15_TX	11	O									
PCIE2_CLKREQn	12	IO											

ADVANCE INFORMATION



**表 6-1. Pin Attributes (ALY Package) (continued)**

Ball Num [1]	Ball Name [2] PADCFG Register [15] PADCFG Address [16]	Signal Name [3]	Mux Mode [4]	Signal Type [5]	I/O Voltage [6]	Ball State DURING Reset (RX/TX/PULL) [7]	Ball State AFTER Reset (RX/TX/PULL) [8]	Mux Mode AFTER Reset [9]	Pull Type [10]	Power [11]	Hys [12]	Voltage Buffer Type [13]	IO RET [14]
AB36	MMC1_CMD PADCFG: PADCONFIG_66 0x0011C108	MMC1_CMD	0	IO	1.8 V/3.3 V	Off / Off / Off	Off / Off / Off	7	PU/PD	VDDSHV5	Yes	SDIO	No
		UART8_TXD	1	O									
		TIMER_IO7	3	IO									
		EHRPWM2_A	4	IO									
		UART4_RTSn	5	O									
		GPIO0_65	7	IO									
		SPI1_D1	8	IO									
		I2C6_SCL	10	IOD									
		MCAN15_RX	11	I									
PCIE3_CLKREQn	12	IO											
AK9	MMC0_DAT0	MMC0_DAT0		IO	1.8 V				PU/PD	VDDSD_MMC0		eMMC PHY	No
AL6	MMC0_DAT1	MMC0_DAT1		IO	1.8 V				PU/PD	VDDSD_MMC0		eMMC PHY	No
AK8	MMC0_DAT2	MMC0_DAT2		IO	1.8 V				PU/PD	VDDSD_MMC0		eMMC PHY	No
AK6	MMC0_DAT3	MMC0_DAT3		IO	1.8 V				PU/PD	VDDSD_MMC0		eMMC PHY	No
AK7	MMC0_DAT4	MMC0_DAT4		IO	1.8 V				PU/PD	VDDSD_MMC0		eMMC PHY	No
AL7	MMC0_DAT5	MMC0_DAT5		IO	1.8 V				PU/PD	VDDSD_MMC0		eMMC PHY	No
AL5	MMC0_DAT6	MMC0_DAT6		IO	1.8 V				PU/PD	VDDSD_MMC0		eMMC PHY	No
AK3	MMC0_DAT7	MMC0_DAT7		IO	1.8 V				PU/PD	VDDSD_MMC0		eMMC PHY	No
AA33	MMC1_DAT0 PADCFG: PADCONFIG_63 0x0011C0FC	MMC1_DAT0	0	IO	1.8 V/3.3 V	Off / Off / Off	Off / Off / Off	7	PU/PD	VDDSHV5	Yes	SDIO	No
		UART7_RTSn	1	O									
		ECAP1_IN_APWM_OUT	2	IO									
		TIMER_IO5	3	IO									
		EHRPWM1_A	4	IO									
		UART4_TXD	5	O									
		GPIO0_63	7	IO									
		SPI1_D0	8	IO									
		UART5_RTSn	9	O									
		I2C4_SCL	10	IOD									
UART2_TXD	11	O											

**表 6-1. Pin Attributes (ALY Package) (continued)**

Ball Num [1]	Ball Name [2] PADCFG Register [15] PADCFG Address [16]	Signal Name [3]	Mux Mode [4]	Signal Type [5]	I/O Voltage [6]	Ball State DURING Reset (RX/TX/PULL) [7]	Ball State AFTER Reset (RX/TX/PULL) [8]	Mux Mode AFTER Reset [9]	Pull Type [10]	Power [11]	Hys [12]	Voltage Buffer Type [13]	IO RET [14]
AB34	MMC1_DAT1 PADCFG: PADCONFIG_62 0x0011C0F8	MMC1_DAT1	0	IO	1.8 V/3.3 V	Off / Off / Off	Off / Off / Off	7	PU/PD	VDDSHV5	Yes	SDIO	No
		UART7_CTSn	1	I									
		ECAPO_IN_APWM_OUT	2	IO									
		TIMER_IO4	3	IO									
		EHRPWM1_B	4	IO									
		UART4_RXD	5	I									
		EHRPWM4_A	6	IO									
		GPIO0_62	7	IO									
		SPI1_CS2	8	IO									
		UART5_CTSn	9	I									
		I2C4_SDA	10	IOD									
UART2_RXD	11	I											
AA32	MMC1_DAT2 PADCFG: PADCONFIG_61 0x0011C0F4	MMC1_DAT2	0	IO	1.8 V/3.3 V	Off / Off / Off	Off / Off / Off	7	PU/PD	VDDSHV5	Yes	SDIO	No
		UART7_TXD	1	O									
		TIMER_IO3	3	IO									
		EHRPWM0_A	4	IO									
		GPIO0_61	7	IO									
		SPI1_CS1	8	IO									
		CPTS0_TS_SYNC	9	O									
		I2C3_SDA	10	IOD									
UART5_TXD	11	O											
AC38	MMC1_DAT3 PADCFG: PADCONFIG_60 0x0011C0F0	MMC1_DAT3	0	IO	1.8 V/3.3 V	Off / Off / Off	Off / Off / Off	7	PU/PD	VDDSHV5	Yes	SDIO	No
		UART7_RXD	1	I									
		PCIE1_CLKREQn	2	IO									
		TIMER_IO2	3	IO									
		EHRPWM0_B	4	IO									
		EHRPWM3_A	6	IO									
		GPIO0_60	7	IO									
		SPI1_CS0	8	IO									
		UART0_CTSn	9	I									
I2C3_SCL	10	IOD											
UART5_RXD	11	I											
P38	OSC1_XI	OSC1_XI		I	1.8 V					VDDA_OSC1	Yes	HFXOSC	
N37	OSC1_XO	OSC1_XO		O	1.8 V					VDDA_OSC1	Yes	HFXOSC	

ADVANCE INFORMATION

**表 6-1. Pin Attributes (ALY Package) (continued)**

Ball Num [1]	Ball Name [2] PADCFG Register [15] PADCFG Address [16]	Signal Name [3]	Mux Mode [4]	Signal Type [5]	I/O Voltage [6]	Ball State DURING Reset (RX/TX/PULL) [7]	Ball State AFTER Reset (RX/TX/PULL) [8]	Mux Mode AFTER Reset [9]	Pull Type [10]	Power [11]	Hys [12]	Voltage Buffer Type [13]	IO RET [14]
AP4	PCIE_REFCLK0_N_OUT	PCIE_REFCLK0_N_OUT		O	1.8 V					VDDA_0P8_S ERDES0_1 / VDDA_0P8_S ERDES_C0_1 / VDDA_1P8_S ERDES0_1		4L_PHY	
AP5	PCIE_REFCLK0_P_OUT	PCIE_REFCLK0_P_OUT		O	1.8 V					VDDA_0P8_S ERDES0_1 / VDDA_0P8_S ERDES_C0_1 / VDDA_1P8_S ERDES0_1		4L_PHY	
AN8	PCIE_REFCLK1_N_OUT	PCIE_REFCLK1_N_OUT		O	1.8 V					VDDA_0P8_S ERDES0_1 / VDDA_0P8_S ERDES_C0_1 / VDDA_1P8_S ERDES0_1		4L_PHY	
AN9	PCIE_REFCLK1_P_OUT	PCIE_REFCLK1_P_OUT		O	1.8 V					VDDA_0P8_S ERDES0_1 / VDDA_0P8_S ERDES_C0_1 / VDDA_1P8_S ERDES0_1		4L_PHY	
AN5	PCIE_REFCLK2_N_OUT	PCIE_REFCLK2_N_OUT		O	1.8 V					VDDA_0P8_S ERDES0_1 / VDDA_0P8_S ERDES_C0_1 / VDDA_1P8_S ERDES0_1		4L_PHY	
AN6	PCIE_REFCLK2_P_OUT	PCIE_REFCLK2_P_OUT		O	1.8 V					VDDA_0P8_S ERDES0_1 / VDDA_0P8_S ERDES_C0_1 / VDDA_1P8_S ERDES0_1		4L_PHY	
AP7	PCIE_REFCLK3_N_OUT	PCIE_REFCLK3_N_OUT		O	1.8 V					VDDA_0P8_S ERDES0_1 / VDDA_0P8_S ERDES_C0_1 / VDDA_1P8_S ERDES0_1		4L_PHY	

**ADVANCE INFORMATION**

表 6-1. Pin Attributes (ALY Package) (continued)

Ball Num [1]	Ball Name [2] PADCFG Register [15] PADCFG Address [16]	Signal Name [3]	Mux Mode [4]	Signal Type [5]	I/O Voltage [6]	Ball State DURING Reset (RX/TX/PULL) [7]	Ball State AFTER Reset (RX/TX/PULL) [8]	Mux Mode AFTER Reset [9]	Pull Type [10]	Power [11]	Hys [12]	Voltage Buffer Type [13]	IO RET [14]
AP8	PCIE_REFCLK3_P_OUT	PCIE_REFCLK3_P_OUT		O	1.8 V					VDDA_0P8_S ERDES0_1 / VDDA_0P8_S ERDES_C0_1 / VDDA_1P8_S ERDES0_1		4L_PHY	
L38	PMIC_POWER_EN1 PADCFG: WKUP_PADCONFIG_68 0x4301C110	PMIC_POWER_EN1	0	O	1.8 V/3.3 V	Off / Off / Off	Off / Off / Off	7	PU/PD	VDDSHV0_M CU	Yes	LVCMOS	Yes
		MCU_I3C0_SDPULLEN	5	OD									
		WKUP_GPIO0_88	7	IO									
AJ34	PMIC_WAKE0n PADCFG: PADCONFIG_13 0x0011C034	PMIC_WAKE0n	0	O	1.8 V/3.3 V	Off / Off / Off	Off / Off / Off	7	PU/PD	VDDSHV2	Yes	LVCMOS	No
		MCASP4_AXR0	1	IO									
		DSS_FSYNC1	4	O									
		MCAN17_RX	5	I									
		GPMC0_WEn	6	O									
		GPIO0_13	7	IO									
		SPI6_CS0	8	IO									
		TRC_DATA0	10	O									
		UART9_RTSn	11	O									
UART7_TXD	13	O											
	AUDIO_EXT_REFCLK0	14	IO										
P33	PORz PADCFG: WKUP_PADCONFIG_94 0x4301C178	PORz	0	I	1.8 V			0		VDDA_WKUP	Yes	FS_RESET	No
AL38	RESETSTATz PADCFG: PADCONFIG_67 0x0011C10C	RESETSTATz	0	O	1.8 V/3.3 V	Off / Low / Off	Off / SS / Off	0	PU/PD	VDDSHV0	Yes	LVCMOS	No
F34	RESET_REQz PADCFG: WKUP_PADCONFIG_93 0x4301C174	RESET_REQz	0	I	1.8 V/3.3 V	On / Off / Up	On / Off / Up	0	PU/PD	VDDSHV0_M CU	Yes	LVCMOS	No
AU9	SERDES0_REFCLK_N	SERDES0_REFCLK_N		IO	1.8 V					VDDA_0P8_S ERDES0_1 / VDDA_0P8_S ERDES_C0_1 / VDDA_1P8_S ERDES0_1		4L_PHY	

ADVANCE INFORMATION

**表 6-1. Pin Attributes (ALY Package) (continued)**

Ball Num [1]	Ball Name [2] PADCFG Register [15] PADCFG Address [16]	Signal Name [3]	Mux Mode [4]	Signal Type [5]	I/O Voltage [6]	Ball State DURING Reset (RX/TX/PULL) [7]	Ball State AFTER Reset (RX/TX/PULL) [8]	Mux Mode AFTER Reset [9]	Pull Type [10]	Power [11]	Hys [12]	Voltage Buffer Type [13]	IO RET [14]
AU8	SERDES0_REFCLK_P	SERDES0_REFCLK_P		IO	1.8 V					VDDA_0P8_S ERDES0_1 / VDDA_0P8_S ERDES_C0_1 / VDDA_1P8_S ERDES0_1		4L_PHY	
AN11	SERDES0_REXT	SERDES0_REXT		I	1.8 V					VDDA_0P8_S ERDES0_1 / VDDA_0P8_S ERDES_C0_1 / VDDA_1P8_S ERDES0_1		4L_PHY	
AV3	SERDES1_REFCLK_N	SERDES1_REFCLK_N	0	IO	1.8 V					VDDA_0P8_S ERDES0_1 / VDDA_0P8_S ERDES_C0_1 / VDDA_1P8_S ERDES0_1		4L_PHY	
AV4	SERDES1_REFCLK_P	SERDES1_REFCLK_P	0	IO	1.8 V					VDDA_0P8_S ERDES0_1 / VDDA_0P8_S ERDES_C0_1 / VDDA_1P8_S ERDES0_1		4L_PHY	
AL9	SERDES1_REXT	SERDES1_REXT	0	I	1.8 V					VDDA_0P8_S ERDES0_1 / VDDA_0P8_S ERDES_C0_1 / VDDA_1P8_S ERDES0_1		4L_PHY	
AV21	SERDES2_REFCLK_N	SERDES2_REFCLK_N		IO	1.8 V					VDDA_0P8_S ERDES2 / VDDA_0P8_S ERDES_C2 / VDDA_1P8_S ERDES2		4L_PHY	
AV22	SERDES2_REFCLK_P	SERDES2_REFCLK_P		IO	1.8 V					VDDA_0P8_S ERDES2 / VDDA_0P8_S ERDES_C2 / VDDA_1P8_S ERDES2		4L_PHY	
AL20	SERDES2_REXT	SERDES2_REXT	0	IO	1.8 V					VDDA_0P8_S ERDES2 / VDDA_0P8_S ERDES_C2 / VDDA_1P8_S ERDES2		4L_PHY	

表 6-1. Pin Attributes (ALY Package) (continued)

Ball Num [1]	Ball Name [2] PADCFG Register [15] PADCFG Address [16]	Signal Name [3]	Mux Mode [4]	Signal Type [5]	I/O Voltage [6]	Ball State DURING Reset (RX/TX/PULL) [7]	Ball State AFTER Reset (RX/TX/PULL) [8]	Mux Mode AFTER Reset [9]	Pull Type [10]	Power [11]	Hys [12]	Voltage Buffer Type [13]	IO RET [14]
AV16	SERDES4_REFCLK_N	SERDES4_REFCLK_N		IO	1.8 V					VDDA_0P8_S ERDES4 / VDDA_0P8_S ERDES_C4 / VDDA_1P8_S ERDES4		4L_PHY	
AV15	SERDES4_REFCLK_P	SERDES4_REFCLK_P		IO	1.8 V					VDDA_0P8_S ERDES4 / VDDA_0P8_S ERDES_C4 / VDDA_1P8_S ERDES4		4L_PHY	
AM19	SERDES4_REXT	SERDES4_REXT		IO	1.8 V					VDDA_0P8_S ERDES4 / VDDA_0P8_S ERDES_C4 / VDDA_1P8_S ERDES4		4L_PHY	
AR8	SERDES0_RX0_N	HYP_RXN0		I	1.8 V					VDDA_0P8_S ERDES0_1 / VDDA_0P8_S ERDES_C0_1 / VDDA_1P8_S ERDES0_1		4L_PHY	
		PCIE1_RXN0		I									
AR9	SERDES0_RX0_P	PCIE1_RXP0	1	I	1.8 V					VDDA_0P8_S ERDES0_1 / VDDA_0P8_S ERDES_C0_1 / VDDA_1P8_S ERDES0_1		4L_PHY	
		HYP_RXP0	4	I									
AT10	SERDES0_RX1_N	PCIE1_RXN1	1	I	1.8 V					VDDA_0P8_S ERDES0_1 / VDDA_0P8_S ERDES_C0_1 / VDDA_1P8_S ERDES0_1		4L_PHY	
		HYP_RXN1	4	I									
AT11	SERDES0_RX1_P	HYP_RXP1		I	1.8 V					VDDA_0P8_S ERDES0_1 / VDDA_0P8_S ERDES_C0_1 / VDDA_1P8_S ERDES0_1		4L_PHY	
		PCIE1_RXP1		I									
AR11	SERDES0_RX2_N	PCIE1_RXN2		I	1.8 V					VDDA_0P8_S ERDES0_1 / VDDA_0P8_S ERDES_C0_1 / VDDA_1P8_S ERDES0_1		4L_PHY	
		PCIE3_RXN0		I									
		USB0_SSRX1N		I									
		HYP_RXN2		I									

ADVANCE INFORMATION

**表 6-1. Pin Attributes (ALY Package) (continued)**

Ball Num [1]	Ball Name [2] PADCFG Register [15] PADCFG Address [16]	Signal Name [3]	Mux Mode [4]	Signal Type [5]	I/O Voltage [6]	Ball State DURING Reset (RX/TX/PULL) [7]	Ball State AFTER Reset (RX/TX/PULL) [8]	Mux Mode AFTER Reset [9]	Pull Type [10]	Power [11]	Hys [12]	Voltage Buffer Type [13]	IO RET [14]
AR12	SERDES0_RX2_P	PCIE3_RXP0		I	1.8 V					VDDA_0P8_S ERDES0_1 / VDDA_0P8_S ERDES_C0_1 / VDDA_1P8_S ERDES0_1		4L_PHY	
		PCIE1_RXP2		I									
		USB0_SSRX1P		I									
		HYP_RXP2		I									
AU11	SERDES0_RX3_N	HYP_RXN3		I	1.8 V					VDDA_0P8_S ERDES0_1 / VDDA_0P8_S ERDES_C0_1 / VDDA_1P8_S ERDES0_1		4L_PHY	
		USB0_SSRX2N		I									
		PCIE3_RXN1		I									
		PCIE1_RXN3		I									
AU12	SERDES0_RX3_P	HYP_RXP3		I	1.8 V					VDDA_0P8_S ERDES0_1 / VDDA_0P8_S ERDES_C0_1 / VDDA_1P8_S ERDES0_1		4L_PHY	
		PCIE3_RXP1		I									
		PCIE1_RXP3		I									
		USB0_SSRX2P		I									
AT7	SERDES0_TX0_N	PCIE1_TXN0	1	O	1.8 V					VDDA_0P8_S ERDES0_1 / VDDA_0P8_S ERDES_C0_1 / VDDA_1P8_S ERDES0_1		4L_PHY	
		HYP_TXN0	4	O									
AT8	SERDES0_TX0_P	PCIE1_TXP0	1	O	1.8 V					VDDA_0P8_S ERDES0_1 / VDDA_0P8_S ERDES_C0_1 / VDDA_1P8_S ERDES0_1		4L_PHY	
		HYP_TXP0	4	O									
AP10	SERDES0_TX1_N	PCIE1_TXN1	1	O	1.8 V					VDDA_0P8_S ERDES0_1 / VDDA_0P8_S ERDES_C0_1 / VDDA_1P8_S ERDES0_1		4L_PHY	
		HYP_TXN1	4	O									
AP11	SERDES0_TX1_P	PCIE1_TXP1	1	O	1.8 V					VDDA_0P8_S ERDES0_1 / VDDA_0P8_S ERDES_C0_1 / VDDA_1P8_S ERDES0_1		4L_PHY	
		HYP_TXP1	4	O									

**表 6-1. Pin Attributes (ALY Package) (continued)**

Ball Num [1]	Ball Name [2] PADCFG Register [15] PADCFG Address [16]	Signal Name [3]	Mux Mode [4]	Signal Type [5]	I/O Voltage [6]	Ball State DURING Reset (RX/TX/PULL) [7]	Ball State AFTER Reset (RX/TX/PULL) [8]	Mux Mode AFTER Reset [9]	Pull Type [10]	Power [11]	Hys [12]	Voltage Buffer Type [13]	IO RET [14]
AV9	SERDES0_TX2_N	PCIE1_TXN2	1	O	1.8 V					VDDA_0P8_S ERDES0_1 / VDDA_0P8_S ERDES_C0_1 / VDDA_1P8_S ERDES0_1		4L_PHY	
		USB0_SSTX1N	2	O									
		PCIE3_TXN0	3	O									
		HYP_TXN2	4	O									
AV10	SERDES0_TX2_P	PCIE1_TXP2	1	O	1.8 V					VDDA_0P8_S ERDES0_1 / VDDA_0P8_S ERDES_C0_1 / VDDA_1P8_S ERDES0_1		4L_PHY	
		USB0_SSTX1P	2	O									
		PCIE3_TXP0	3	O									
		HYP_TXP2	4	O									
AV12	SERDES0_TX3_N	USB0_SSTX2N		O	1.8 V					VDDA_0P8_S ERDES0_1 / VDDA_0P8_S ERDES_C0_1 / VDDA_1P8_S ERDES0_1		4L_PHY	
		PCIE3_TXN1		O									
		HYP_TXN3		O									
		PCIE1_TXN3		O									
AV13	SERDES0_TX3_P	HYP_TXP3		O	1.8 V					VDDA_0P8_S ERDES0_1 / VDDA_0P8_S ERDES_C0_1 / VDDA_1P8_S ERDES0_1		4L_PHY	
		USB0_SSTX2P		O									
		PCIE3_TXP1		O									
		PCIE1_TXP3		O									
AU5	SERDES1_RX0_N	PCIE0_RXN0		I	1.8 V					VDDA_0P8_S ERDES0_1 / VDDA_0P8_S ERDES_C0_1 / VDDA_1P8_S ERDES0_1		4L_PHY	
		SGMII3_RXN0		I									
AU6	SERDES1_RX0_P	PCIE0_RXP0		I	1.8 V					VDDA_0P8_S ERDES0_1 / VDDA_0P8_S ERDES_C0_1 / VDDA_1P8_S ERDES0_1		4L_PHY	
		SGMII3_RXP0		I									
AT4	SERDES1_RX1_N	SGMII4_RXN0		I	1.8 V					VDDA_0P8_S ERDES0_1 / VDDA_0P8_S ERDES_C0_1 / VDDA_1P8_S ERDES0_1		4L_PHY	
		PCIE0_RXN1		I									

**ADVANCE INFORMATION**



**表 6-1. Pin Attributes (ALY Package) (continued)**

Ball Num [1]	Ball Name [2] PADCFG Register [15] PADCFG Address [16]	Signal Name [3]	Mux Mode [4]	Signal Type [5]	I/O Voltage [6]	Ball State DURING Reset (RX/TX/PULL) [7]	Ball State AFTER Reset (RX/TX/PULL) [8]	Mux Mode AFTER Reset [9]	Pull Type [10]	Power [11]	Hys [12]	Voltage Buffer Type [13]	IO RET [14]																																																																																																																																																																		
AT5	SERDES1_RX1_P	SGMII4_RXP0		I	1.8 V					VDDA_0P8_S ERDES0_1 / VDDA_0P8_S ERDES_C0_1 / VDDA_1P8_S ERDES0_1		4L_PHY																																																																																																																																																																			
		PCIE0_RXP1		I									AU2	SERDES1_RX2_N	PCIE2_RXN0		I	1.8 V					VDDA_0P8_S ERDES0_1 / VDDA_0P8_S ERDES_C0_1 / VDDA_1P8_S ERDES0_1		4L_PHY		PCIE0_RXN2		I						SGMII1_RXN0		I							AU3	SERDES1_RX2_P	SGMII1_RXP0		I	1.8 V					VDDA_0P8_S ERDES0_1 / VDDA_0P8_S ERDES_C0_1 / VDDA_1P8_S ERDES0_1		4L_PHY		PCIE2_RXP0		I						PCIE0_RXP2		I							AT1	SERDES1_RX3_N	PCIE0_RXN3		I	1.8 V					VDDA_0P8_S ERDES0_1 / VDDA_0P8_S ERDES_C0_1 / VDDA_1P8_S ERDES0_1		4L_PHY		PCIE2_RXN1		I						SGMII2_RXN0		I							AT2	SERDES1_RX3_P	PCIE0_RXP3		I	1.8 V					VDDA_0P8_S ERDES0_1 / VDDA_0P8_S ERDES_C0_1 / VDDA_1P8_S ERDES0_1		4L_PHY		SGMII2_RXP0		I						PCIE2_RXP1		I							AV6	SERDES1_TX0_N	SGMII3_TXN0		O	1.8 V					VDDA_0P8_S ERDES0_1 / VDDA_0P8_S ERDES_C0_1 / VDDA_1P8_S ERDES0_1		4L_PHY		PCIE0_TXN0		O						AV7	SERDES1_TX0_P	PCIE0_TXP0		O	1.8 V					VDDA_0P8_S ERDES0_1 / VDDA_0P8_S ERDES_C0_1 / VDDA_1P8_S ERDES0_1		4L_PHY		SGMII3_TXP0		O
AU2	SERDES1_RX2_N	PCIE2_RXN0		I	1.8 V					VDDA_0P8_S ERDES0_1 / VDDA_0P8_S ERDES_C0_1 / VDDA_1P8_S ERDES0_1		4L_PHY																																																																																																																																																																			
		PCIE0_RXN2		I																																																																																																																																																																											
		SGMII1_RXN0		I																																																																																																																																																																											
AU3	SERDES1_RX2_P	SGMII1_RXP0		I	1.8 V					VDDA_0P8_S ERDES0_1 / VDDA_0P8_S ERDES_C0_1 / VDDA_1P8_S ERDES0_1		4L_PHY																																																																																																																																																																			
		PCIE2_RXP0		I																																																																																																																																																																											
		PCIE0_RXP2		I																																																																																																																																																																											
AT1	SERDES1_RX3_N	PCIE0_RXN3		I	1.8 V					VDDA_0P8_S ERDES0_1 / VDDA_0P8_S ERDES_C0_1 / VDDA_1P8_S ERDES0_1		4L_PHY																																																																																																																																																																			
		PCIE2_RXN1		I																																																																																																																																																																											
		SGMII2_RXN0		I																																																																																																																																																																											
AT2	SERDES1_RX3_P	PCIE0_RXP3		I	1.8 V					VDDA_0P8_S ERDES0_1 / VDDA_0P8_S ERDES_C0_1 / VDDA_1P8_S ERDES0_1		4L_PHY																																																																																																																																																																			
		SGMII2_RXP0		I																																																																																																																																																																											
		PCIE2_RXP1		I																																																																																																																																																																											
AV6	SERDES1_TX0_N	SGMII3_TXN0		O	1.8 V					VDDA_0P8_S ERDES0_1 / VDDA_0P8_S ERDES_C0_1 / VDDA_1P8_S ERDES0_1		4L_PHY																																																																																																																																																																			
		PCIE0_TXN0		O																																																																																																																																																																											
AV7	SERDES1_TX0_P	PCIE0_TXP0		O	1.8 V					VDDA_0P8_S ERDES0_1 / VDDA_0P8_S ERDES_C0_1 / VDDA_1P8_S ERDES0_1		4L_PHY																																																																																																																																																																			
		SGMII3_TXP0		O																																																																																																																																																																											

表 6-1. Pin Attributes (ALY Package) (continued)

Ball Num [1]	Ball Name [2] PADCFG Register [15] PADCFG Address [16]	Signal Name [3]	Mux Mode [4]	Signal Type [5]	I/O Voltage [6]	Ball State DURING Reset (RX/TX/PULL) [7]	Ball State AFTER Reset (RX/TX/PULL) [8]	Mux Mode AFTER Reset [9]	Pull Type [10]	Power [11]	Hys [12]	Voltage Buffer Type [13]	IO RET [14]
AR5	SERDES1_TX1_N	PCIE0_TXN1		O	1.8 V					VDDA_0P8_S ERDES0_1 / VDDA_0P8_S ERDES_C0_1 / VDDA_1P8_S ERDES0_1		4L_PHY	
		SGMII4_TXN0		O									
AR6	SERDES1_TX1_P	PCIE0_TXP1		O	1.8 V					VDDA_0P8_S ERDES0_1 / VDDA_0P8_S ERDES_C0_1 / VDDA_1P8_S ERDES0_1		4L_PHY	
		SGMII4_TXP0		O									
AR2	SERDES1_TX2_N	PCIE0_TXN2		O	1.8 V					VDDA_0P8_S ERDES0_1 / VDDA_0P8_S ERDES_C0_1 / VDDA_1P8_S ERDES0_1		4L_PHY	
		SGMII1_TXN0		O									
		PCIE2_TXN0		O									
AR3	SERDES1_TX2_P	PCIE2_TXP0		O	1.8 V					VDDA_0P8_S ERDES0_1 / VDDA_0P8_S ERDES_C0_1 / VDDA_1P8_S ERDES0_1		4L_PHY	
		SGMII1_TXP0		O									
		PCIE0_TXP2		O									
AP1	SERDES1_TX3_N	PCIE2_TXN1		O	1.8 V					VDDA_0P8_S ERDES0_1 / VDDA_0P8_S ERDES_C0_1 / VDDA_1P8_S ERDES0_1		4L_PHY	
		PCIE0_TXN3		O									
		SGMII2_TXN0		O									
AP2	SERDES1_TX3_P	SGMII2_TXP0		O	1.8 V					VDDA_0P8_S ERDES0_1 / VDDA_0P8_S ERDES_C0_1 / VDDA_1P8_S ERDES0_1		4L_PHY	
		PCIE0_TXP3		O									
		PCIE2_TXP1		O									
AU23	SERDES2_RX0_N	SGMII5_RXN0	0	I	1.8 V					VDDA_0P8_S ERDES2 / VDDA_0P8_S ERDES_C2 / VDDA_1P8_S ERDES2		4L_PHY	
AU24	SERDES2_RX0_P	SGMII5_RXP0	0	I	1.8 V					VDDA_0P8_S ERDES2 / VDDA_0P8_S ERDES_C2 / VDDA_1P8_S ERDES2		4L_PHY	

ADVANCE INFORMATION

**表 6-1. Pin Attributes (ALY Package) (continued)**

Ball Num [1]	Ball Name [2] PADCFG Register [15] PADCFG Address [16]	Signal Name [3]	Mux Mode [4]	Signal Type [5]	I/O Voltage [6]	Ball State DURING Reset (RX/TX/PULL) [7]	Ball State AFTER Reset (RX/TX/PULL) [8]	Mux Mode AFTER Reset [9]	Pull Type [10]	Power [11]	Hys [12]	Voltage Buffer Type [13]	IO RET [14]
AT22	SERDES2_RX1_N	SGMII6_RXN0	0	I	1.8 V					VDDA_0P8_S ERDES2 / VDDA_0P8_S ERDES_C2 / VDDA_1P8_S ERDES2		4L_PHY	
AT23	SERDES2_RX1_P	SGMII6_RXP0	0	I	1.8 V					VDDA_0P8_S ERDES2 / VDDA_0P8_S ERDES_C2 / VDDA_1P8_S ERDES2		4L_PHY	
AU20	SERDES2_RX2_N	SGMII7_RXN0	0	I	1.8 V					VDDA_0P8_S ERDES2 / VDDA_0P8_S ERDES_C2 / VDDA_1P8_S ERDES2		4L_PHY	
		SGMII1_RXN0	1	I									
AU21	SERDES2_RX2_P	SGMII7_RXP0	0	I	1.8 V					VDDA_0P8_S ERDES2 / VDDA_0P8_S ERDES_C2 / VDDA_1P8_S ERDES2		4L_PHY	
		SGMII1_RXP0	1	I									
AT19	SERDES2_RX3_N	SGMII8_RXN0	0	I	1.8 V					VDDA_0P8_S ERDES2 / VDDA_0P8_S ERDES_C2 / VDDA_1P8_S ERDES2		4L_PHY	
		SGMII2_RXN0	1	I									
AT20	SERDES2_RX3_P	SGMII8_RXP0	0	I	1.8 V					VDDA_0P8_S ERDES2 / VDDA_0P8_S ERDES_C2 / VDDA_1P8_S ERDES2		4L_PHY	
		SGMII2_RXP0	1	I									
AV24	SERDES2_TX0_N	SGMII5_TXN0	0	O	1.8 V					VDDA_0P8_S ERDES2 / VDDA_0P8_S ERDES_C2 / VDDA_1P8_S ERDES2		4L_PHY	
AV25	SERDES2_TX0_P	SGMII5_TXP0	0	O	1.8 V					VDDA_0P8_S ERDES2 / VDDA_0P8_S ERDES_C2 / VDDA_1P8_S ERDES2		4L_PHY	

表 6-1. Pin Attributes (ALY Package) (continued)

Ball Num [1]	Ball Name [2] PADCFG Register [15] PADCFG Address [16]	Signal Name [3]	Mux Mode [4]	Signal Type [5]	I/O Voltage [6]	Ball State DURING Reset (RX/TX/PULL) [7]	Ball State AFTER Reset (RX/TX/PULL) [8]	Mux Mode AFTER Reset [9]	Pull Type [10]	Power [11]	Hys [12]	Voltage Buffer Type [13]	IO RET [14]
AR23	SERDES2_TX1_N	SGMII6_TXN0	0	O	1.8 V					VDDA_0P8_S ERDES2 / VDDA_0P8_S ERDES_C2 / VDDA_1P8_S ERDES2		4L_PHY	
AR24	SERDES2_TX1_P	SGMII6_TXP0	0	O	1.8 V					VDDA_0P8_S ERDES2 / VDDA_0P8_S ERDES_C2 / VDDA_1P8_S ERDES2		4L_PHY	
AR20	SERDES2_TX2_N	SGMII7_TXN0	0	O	1.8 V					VDDA_0P8_S ERDES2 / VDDA_0P8_S ERDES_C2 / VDDA_1P8_S ERDES2		4L_PHY	
		SGMII1_TXN0	1	O									
AR21	SERDES2_TX2_P	SGMII7_TXP0		O	1.8 V					VDDA_0P8_S ERDES2 / VDDA_0P8_S ERDES_C2 / VDDA_1P8_S ERDES2		4L_PHY	
		SGMII1_TXP0		O									
AP19	SERDES2_TX3_N	SGMII8_TXN0		O	1.8 V					VDDA_0P8_S ERDES2 / VDDA_0P8_S ERDES_C2 / VDDA_1P8_S ERDES2		4L_PHY	
		SGMII2_TXN0		O									
AP20	SERDES2_TX3_P	SGMII2_TXP0		O	1.8 V					VDDA_0P8_S ERDES2 / VDDA_0P8_S ERDES_C2 / VDDA_1P8_S ERDES2		4L_PHY	
		SGMII8_TXP0		O									
AR14	SERDES4_RX0_N	HYP_RXN0		I	1.8 V					VDDA_0P8_S ERDES4 / VDDA_0P8_S ERDES_C4 / VDDA_1P8_S ERDES4		4L_PHY	
		SGMII5_RXN0		I									
AR15	SERDES4_RX0_P	SGMII5_RXP0		I	1.8 V					VDDA_0P8_S ERDES4 / VDDA_0P8_S ERDES_C4 / VDDA_1P8_S ERDES4		4L_PHY	
		HYP_RXP0		I									

ADVANCE INFORMATION

**表 6-1. Pin Attributes (ALY Package) (continued)**

Ball Num [1]	Ball Name [2] PADCFG Register [15] PADCFG Address [16]	Signal Name [3]	Mux Mode [4]	Signal Type [5]	I/O Voltage [6]	Ball State DURING Reset (RX/TX/PULL) [7]	Ball State AFTER Reset (RX/TX/PULL) [8]	Mux Mode AFTER Reset [9]	Pull Type [10]	Power [11]	Hys [12]	Voltage Buffer Type [13]	IO RET [14]
AU14	SERDES4_RX1_N	SGMII6_RXN0		I	1.8 V					VDDA_0P8_S ERDES4 / VDDA_0P8_S ERDES_C4 / VDDA_1P8_S ERDES4		4L_PHY	
		HYP_RXN1		I									
AU15	SERDES4_RX1_P	HYP_RXP1		I	1.8 V					VDDA_0P8_S ERDES4 / VDDA_0P8_S ERDES_C4 / VDDA_1P8_S ERDES4		4L_PHY	
		SGMII6_RXP0		I									
AR17	SERDES4_RX2_N	USB0_SSRX1N		I	1.8 V					VDDA_0P8_S ERDES4 / VDDA_0P8_S ERDES_C4 / VDDA_1P8_S ERDES4		4L_PHY	
		HYP_RXN2		I									
		SGMII7_RXN0		I									
AR18	SERDES4_RX2_P	USB0_SSRX1P		I	1.8 V					VDDA_0P8_S ERDES4 / VDDA_0P8_S ERDES_C4 / VDDA_1P8_S ERDES4		4L_PHY	
		HYP_RXP2		I									
		SGMII7_RXP0		I									
AU17	SERDES4_RX3_N	HYP_RXN3		I	1.8 V					VDDA_0P8_S ERDES4 / VDDA_0P8_S ERDES_C4 / VDDA_1P8_S ERDES4		4L_PHY	
		USB0_SSRX2N		I									
		SGMII8_RXN0		I									
AU18	SERDES4_RX3_P	HYP_RXP3		I	1.8 V					VDDA_0P8_S ERDES4 / VDDA_0P8_S ERDES_C4 / VDDA_1P8_S ERDES4		4L_PHY	
		USB0_SSRX2P		I									
		SGMII8_RXP0		I									
AP13	SERDES4_TX0_N	DP0_TXN0		O	1.8 V					VDDA_0P8_S ERDES4 / VDDA_0P8_S ERDES_C4 / VDDA_1P8_S ERDES4		4L_PHY	
		SGMII5_TXN0		O									
		HYP_TXN0		O									
AP14	SERDES4_TX0_P	SGMII5_TXP0		O	1.8 V					VDDA_0P8_S ERDES4 / VDDA_0P8_S ERDES_C4 / VDDA_1P8_S ERDES4		4L_PHY	
		HYP_TXP0		O									
		DP0_TXP0		O									

表 6-1. Pin Attributes (ALY Package) (continued)

Ball Num [1]	Ball Name [2] PADCFG Register [15] PADCFG Address [16]	Signal Name [3]	Mux Mode [4]	Signal Type [5]	I/O Voltage [6]	Ball State DURING Reset (RX/TX/PULL) [7]	Ball State AFTER Reset (RX/TX/PULL) [8]	Mux Mode AFTER Reset [9]	Pull Type [10]	Power [11]	Hys [12]	Voltage Buffer Type [13]	IO RET [14]
AT13	SERDES4_TX1_N	HYP_TXN1		O	1.8 V					VDDA_0P8_S ERDES4 / VDDA_0P8_S ERDES_C4 / VDDA_1P8_S ERDES4		4L_PHY	
		SGMII6_TXN0		O									
		DP0_TXN1		O									
AT14	SERDES4_TX1_P	HYP_TXP1		O	1.8 V					VDDA_0P8_S ERDES4 / VDDA_0P8_S ERDES_C4 / VDDA_1P8_S ERDES4		4L_PHY	
		DP0_TXP1		O									
		SGMII6_TXP0		O									
AT16	SERDES4_TX2_N	DP0_TXN2		O	1.8 V					VDDA_0P8_S ERDES4 / VDDA_0P8_S ERDES_C4 / VDDA_1P8_S ERDES4		4L_PHY	
		HYP_TXN2		O									
		SGMII7_TXN0		O									
		USB0_SSTX1N		O									
AT17	SERDES4_TX2_P	SGMII7_TXP0		O	1.8 V					VDDA_0P8_S ERDES4 / VDDA_0P8_S ERDES_C4 / VDDA_1P8_S ERDES4		4L_PHY	
		DP0_TXP2		O									
		HYP_TXP2		O									
		USB0_SSTX1P		O									
AV18	SERDES4_TX3_N	SGMII8_TXN0		O	1.8 V					VDDA_0P8_S ERDES4 / VDDA_0P8_S ERDES_C4 / VDDA_1P8_S ERDES4		4L_PHY	
		USB0_SSTX2N		O									
		DP0_TXN3		O									
		HYP_TXN3		O									
AV19	SERDES4_TX3_P	HYP_TXP3		O	1.8 V					VDDA_0P8_S ERDES4 / VDDA_0P8_S ERDES_C4 / VDDA_1P8_S ERDES4		4L_PHY	
		SGMII8_TXP0		O									
		USB0_SSTX2P		O									
		DP0_TXP3		O									
AM34	SOC_SAFETY_ERRORn PADCFG: PADCONFIG_68 0x0011C110	SOC_SAFETY_ERRORn	0	IO	1.8 V/3.3 V	Off / Off / Down	On / SS / Down	0	PU/PD	VDDSHV0	Yes	LVC MOS	No
AN38	SPI0_CLK PADCFG: PADCONFIG_53 0x0011C0D4	SPI0_CLK	0	IO	1.8 V/3.3 V	Off / Off / Off	Off / Off / Off	7	PU/PD	VDDSHV0	Yes	LVC MOS	No
		UART1_CTSn	1	I									
		I2C2_SCL	2	IOD									
		MCASP3_AXR0	3	IO									
		EHRPWM2_A	5	IO									
		GPIO0_53	7	IO									
UART8_TXD	11	O											

ADVANCE INFORMATION

**表 6-1. Pin Attributes (ALY Package) (continued)**

Ball Num [1]	Ball Name [2] PADCFG Register [15] PADCFG Address [16]	Signal Name [3]	Mux Mode [4]	Signal Type [5]	I/O Voltage [6]	Ball State DURING Reset (RX/TX/PULL) [7]	Ball State AFTER Reset (RX/TX/PULL) [8]	Mux Mode AFTER Reset [9]	Pull Type [10]	Power [11]	Hys [12]	Voltage Buffer Type [13]	IO RET [14]
AM37	SPI0_CS0 PADCFG: PADCONFIG_51 0x0011C0CC	SPI0_CS0	0	IO	1.8 V/3.3 V	Off / Off / Off	Off / Off / Off	7	PU/PD	VDDSHV0	Yes	LVC MOS	No
		MCASP3_ACLKX	3	IO									
		MCASP3_ACLKR	4	IO									
		EHRPWM0_A	5	IO									
		GPIO0_51	7	IO									
		MCAN14_TX	9	O									
		DP0_HP D	12	I									
AP38	SPI0_CS1 PADCFG: PADCONFIG_52 0x0011C0D0	SPI0_CS1	0	IO	1.8 V/3.3 V	Off / Off / Off	Off / Off / Off	7	PU/PD	VDDSHV0	Yes	LVC MOS	No
		CPTS0_TS_COMP	1	O									
		UART0_RT Sn	2	O									
		MCASP3_AFSX	3	IO									
		MCASP3_AFSR	4	IO									
		EHRPWM1_A	5	IO									
		GPIO0_52	7	IO									
		MCAN14_RX	9	I									
UART8_RXD	11	I											
AM35	SPI0_D0 PADCFG: PADCONFIG_54 0x0011C0D8	SPI0_D0	0	IO	1.8 V/3.3 V	Off / Off / Off	Off / Off / Off	7	PU/PD	VDDSHV0	Yes	LVC MOS	No
		UART1_RT Sn	1	O									
		I2C2_SDA	2	IOD									
		MCASP3_AXR1	3	IO									
		EHRPWM3_A	5	IO									
		GPIO0_54	7	IO									
		UART2_RXD	11	I									
AM36	SPI0_D1 PADCFG: PADCONFIG_55 0x0011C0DC	SPI0_D1	0	IO	1.8 V/3.3 V	Off / Off / Off	Off / Off / Off	7	PU/PD	VDDSHV0	Yes	LVC MOS	No
		MCASP3_AXR2	3	IO									
		EHRPWM4_A	5	IO									
		GPIO0_55	7	IO									
		UART2_TXD	11	O									
G35	TCK PADCFG: WKUP_PADCONFIG_73 0x4301C124	TCK	0	I	1.8 V/3.3 V	On / NA / Up	On / Off / Up	0	PU/PD	VDDSHV0_M CU	Yes	LVC MOS	No
AL37	TDI PADCFG: PADCONFIG_69 0x0011C114	TDI	0	I	1.8 V/3.3 V	On / Off / Up	On / Off / Up	0	PU/PD	VDDSHV0	Yes	LVC MOS	No

**表 6-1. Pin Attributes (ALY Package) (continued)**

Ball Num [1]	Ball Name [2] PADCFG Register [15] PADCFG Address [16]	Signal Name [3]	Mux Mode [4]	Signal Type [5]	I/O Voltage [6]	Ball State DURING Reset (RX/TX/PULL) [7]	Ball State AFTER Reset (RX/TX/PULL) [8]	Mux Mode AFTER Reset [9]	Pull Type [10]	Power [11]	Hys [12]	Voltage Buffer Type [13]	IO RET [14]
AL35	TDO PADCFG: PADCONFIG_70 0x0011C118	TDO	0	OZ	1.8 V/3.3 V	Off / Off / Up	Off / SS / Up	0	PU/PD	VDDSHV0	Yes	LVC MOS	No
AR38	TIMER_IO0 PADCFG: PADCONFIG_58 0x0011C0E8	TIMER_IO0	0	IO	1.8 V/3.3 V	Off / Off / Off	Off / Off / Off	7	PU/PD	VDDSHV0	Yes	LVC MOS	No
		ECAP1_IN_APWM_OUT	1	IO									
		SYSCLKOUT0	2	O									
		UART3_RXD	5	I									
		PCIE1_CLKREQn	6	IO									
		GPIO0_58	7	IO									
		MMC1_SD CD	8	I									
		MCAN13_TX	9	O									
I2C6_SDA	13	IOD											
AN37	TIMER_IO1 PADCFG: PADCONFIG_59 0x0011C0EC	TIMER_IO1	0	IO	1.8 V/3.3 V	Off / Off / Off	Off / Off / Off	7	PU/PD	VDDSHV0	Yes	LVC MOS	No
		ECAP2_IN_APWM_OUT	1	IO									
		OB SCLK0	2	O									
		UART3_TXD	5	O									
		USB0_DRVVBUS	6	O									
		GPIO0_59	7	IO									
		MMC1_SD WP	8	I									
		MCAN13_RX	9	I									
		I2C6_SCL	13	IOD									
OB SCLK0	15	O											
AL36	TMS PADCFG: PADCONFIG_71 0x0011C11C	TMS	0	I	1.8 V/3.3 V	On / Off / Up	On / Off / Up	0	PU/PD	VDDSHV0	Yes	LVC MOS	No
G37	TRSTn PADCFG: WKUP_PADCONFIG_74 0x4301C128	TRSTn	0	I	1.8 V/3.3 V	On / NA / Down	On / Off / Down	0	PU/PD	VDDSHV0_M CU	Yes	LVC MOS	No
AM7	UFS0_REF_CLK	UFS0_REF_CLK	0	I	1.2 V					VDDA_1p8_U FS / VDDA_0P8_U FS		M-PHY	
		UFS0_REF_CLK	16	I									
AM8	UFS0_RSTn	UFS0_RSTn	0	I	1.2 V					VDDA_1p8_U FS / VDDA_0P8_U FS		M-PHY	
		UFS0_RSTn	16	I									



**表 6-1. Pin Attributes (ALY Package) (continued)**

Ball Num [1]	Ball Name [2] PADCFG Register [15] PADCFG Address [16]	Signal Name [3]	Mux Mode [4]	Signal Type [5]	I/O Voltage [6]	Ball State DURING Reset (RX/TX/PULL) [7]	Ball State AFTER Reset (RX/TX/PULL) [8]	Mux Mode AFTER Reset [9]	Pull Type [10]	Power [11]	Hys [12]	Voltage Buffer Type [13]	IO RET [14]
AM4	UFS0_RX_DN0	UFS0_RX_DN0	0	I	1.8 V					VDDA_1p8_U FS / VDDA_0P8_U FS		M-PHY	
		UFS0_RX_DN0	16	I									
AM1	UFS0_RX_DN1	UFS0_RX_DN1	0	I	1.8 V					VDDA_1p8_U FS / VDDA_0P8_U FS		M-PHY	
		UFS0_RX_DN1	16	I									
AM5	UFS0_RX_DP0	UFS0_RX_DP0	0	I	1.8 V					VDDA_1p8_U FS / VDDA_0P8_U FS		M-PHY	
		UFS0_RX_DP0	16	I									
AM2	UFS0_RX_DP1	UFS0_RX_DP1	0	I	1.8 V					VDDA_1p8_U FS / VDDA_0P8_U FS		M-PHY	
		UFS0_RX_DP1	16	I									
AL2	UFS0_TX_DN0	UFS0_TX_DN0	0	I	1.8 V					VDDA_1p8_U FS / VDDA_0P8_U FS		M-PHY	
		UFS0_TX_DN0	16	I									
AN2	UFS0_TX_DN1	UFS0_TX_DN1	0	I	1.8 V					VDDA_1p8_U FS / VDDA_0P8_U FS		M-PHY	
		UFS0_TX_DN1	16	I									
AL3	UFS0_TX_DP0	UFS0_TX_DP0	0	I	1.8 V					VDDA_1p8_U FS / VDDA_0P8_U FS		M-PHY	
		UFS0_TX_DP0	16	I									
AN3	UFS0_TX_DP1	UFS0_TX_DP1	0	I	1.8 V					VDDA_1p8_U FS / VDDA_0P8_U FS		M-PHY	
		UFS0_TX_DP1	16	I									
AP16	USB0_DM	USB0_DM		IO	3.3 V					VDDA_0P8_U SB / VDDA_1P8_U SB / VDDA_3P3_U SB		USB2PHY	
AP17	USB0_DP	USB0_DP		IO	3.3 V					VDDA_0P8_U SB / VDDA_1P8_U SB / VDDA_3P3_U SB		USB2PHY	
AN17	USB0_ID	USB0_ID		A	3.3 V					VDDA_0P8_U SB / VDDA_1P8_U SB / VDDA_3P3_U SB		USB2PHY	

**表 6-1. Pin Attributes (ALY Package) (continued)**

Ball Num [1]	Ball Name [2] PADCFG Register [15] PADCFG Address [16]	Signal Name [3]	Mux Mode [4]	Signal Type [5]	I/O Voltage [6]	Ball State DURING Reset (RX/TX/PULL) [7]	Ball State AFTER Reset (RX/TX/PULL) [8]	Mux Mode AFTER Reset [9]	Pull Type [10]	Power [11]	Hys [12]	Voltage Buffer Type [13]	IO RET [14]
AN18	USB0_RCALIB	USB0_RCALIB		A	3.3 V					VDDA_0P8_U SB / VDDA_1P8_U SB / VDDA_3P3_U SB		USB2PHY	
AN15	USB0_VBUS	USB0_VBUS		A	5.0 V					VDDA_0P8_U SB / VDDA_1P8_U SB / VDDA_3P3_U SB		DDR	
AB27, AC24, AF15, AF18, AF21, AG11, AG28, T25	VDDAR_CORE	VDDAR_CORE											
AB13, AC16, AC18, AC20, AE12, M21, N23, T15, U20, W14, W21, Y11, Y19	VDDAR_CPU	VDDAR_CPU											
M27, N24	VDDAR_MCU	VDDAR_MCU											
AJ24	VDDA_0P8_DSITX	VDDA_0P8_DSITX											
AJ25	VDDA_0P8_DSITX_C	VDDA_0P8_DSITX_C											
AH11	VDDA_0P8_UFS	VDDA_0P8_UFS											
AK20	VDDA_0P8_USB	VDDA_0P8_USB											
AJ28	VDDA_0P8_CSIRX2	VDDA_0P8_CSIRX2											
AJ26, AK26	VDDA_0P8_CSIRX0_1	VDDA_0P8_CSIRX0_1											
AE9	VDDA_0P8_DLL_MMC0	VDDA_0P8_DLL_MMC0											
U11	VDDA_0P8_PLL_DDR0	VDDA_0P8_PLL_DDR0											
M14	VDDA_0P8_PLL_DDR1	VDDA_0P8_PLL_DDR1											
N11	VDDA_0P8_PLL_DDR2	VDDA_0P8_PLL_DDR2											
M18	VDDA_0P8_PLL_DDR3	VDDA_0P8_PLL_DDR3											
AJ20, AJ21	VDDA_0P8_SERDES2	VDDA_0P8_SERDES2											
AJ17, AJ18	VDDA_0P8_SERDES4	VDDA_0P8_SERDES4											
AJ12, AJ15, AK13, AK14	VDDA_0P8_SERDES0_1	VDDA_0P8_SERDES0_1											
AG21, AH20	VDDA_0P8_SERDES_C2	VDDA_0P8_SERDES_C2											
AG17, AH18	VDDA_0P8_SERDES_C4	VDDA_0P8_SERDES_C4											

**表 6-1. Pin Attributes (ALY Package) (continued)**

Ball Num [1]	Ball Name [2] PADCFG Register [15] PADCFG Address [16]	Signal Name [3]	Mux Mode [4]	Signal Type [5]	I/O Voltage [6]	Ball State DURING Reset (RX/TX/PULL) [7]	Ball State AFTER Reset (RX/TX/PULL) [8]	Mux Mode AFTER Reset [9]	Pull Type [10]	Power [11]	Hys [12]	Voltage Buffer Type [13]	IO RET [14]
AH12, AH13, AH15, AH16	VDDA_0P8_SERDES_C0_1	VDDA_0P8_SERDES_C0_1		PWR									
AH24, AH25	VDDA_1P8_DSITX	VDDA_1P8_DSITX		PWR									
AJ10	VDDA_1P8_UFS	VDDA_1P8_UFS		PWR									
AK21	VDDA_1P8_USB	VDDA_1P8_USB		PWR									
AH29, AJ29	VDDA_1P8_CSIRX2	VDDA_1P8_CSIRX2		PWR									
AH27, AH28	VDDA_1P8_CSIRX0_1	VDDA_1P8_CSIRX0_1		PWR									
AH21	VDDA_1P8_SERDES2	VDDA_1P8_SERDES2		PWR									
AH17	VDDA_1P8_SERDES4	VDDA_1P8_SERDES4		PWR									
AJ13, AJ14	VDDA_1P8_SERDES0_1	VDDA_1P8_SERDES0_1		PWR									
AJ23	VDDA_1P8_SERDES2_4	VDDA_1P8_SERDES2_4		PWR									
AJ19	VDDA_3P3_USB	VDDA_3P3_USB		PWR									
M31	VDDA_ADC0	VDDA_ADC0		PWR									
N30	VDDA_ADC1	VDDA_ADC1		PWR									
M28	VDDA_MCU_PLLGRP0	VDDA_MCU_PLLGRP0		PWR									
M26	VDDA_MCU_TEMP	VDDA_MCU_TEMP		PWR									
N29	VDDA_OSC1	VDDA_OSC1		PWR									
AA27	VDDA_PLLGRP0	VDDA_PLLGRP0		PWR									
Y28	VDDA_PLLGRP1	VDDA_PLLGRP1		PWR									
AG13	VDDA_PLLGRP2	VDDA_PLLGRP2		PWR									
V14	VDDA_PLLGRP5	VDDA_PLLGRP5		PWR									
R21	VDDA_PLLGRP6	VDDA_PLLGRP6		PWR									
P12	VDDA_PLLGRP7	VDDA_PLLGRP7		PWR									
P15	VDDA_PLLGRP8	VDDA_PLLGRP8		PWR									
Y26	VDDA_PLLGRP9	VDDA_PLLGRP9		PWR									
AG23	VDDA_PLLGRP10	VDDA_PLLGRP10		PWR									
AA23	VDDA_PLLGRP12	VDDA_PLLGRP12		PWR									
AB26	VDDA_PLLGRP13	VDDA_PLLGRP13		PWR									
N28	VDDA_POR_WKUP	VDDA_POR_WKUP		PWR									
Y27	VDDA_TEMP0	VDDA_TEMP0		PWR									
M12	VDDA_TEMP1	VDDA_TEMP1		PWR									
W23	VDDA_TEMP2	VDDA_TEMP2		PWR									
AE13	VDDA_TEMP3	VDDA_TEMP3		PWR									
AD18	VDDA_TEMP4	VDDA_TEMP4		PWR									
K31, L32	VDDA_WKUP	VDDA_WKUP		PWR									
V30, V32, W31	VDDSHV0	VDDSHV0		PWR									

**表 6-1. Pin Attributes (ALY Package) (continued)**

Ball Num [1]	Ball Name [2] PADCFG Register [15] PADCFG Address [16]	Signal Name [3]	Mux Mode [4]	Signal Type [5]	I/O Voltage [6]	Ball State DURING Reset (RX/TX/PULL) [7]	Ball State AFTER Reset (RX/TX/PULL) [8]	Mux Mode AFTER Reset [9]	Pull Type [10]	Power [11]	Hys [12]	Voltage Buffer Type [13]	IO RET [14]
H29, J28, K29	VDDSHV0_MCU	VDDSHV0_MCU		PWR									
H25, J24, K25	VDDSHV1_MCU	VDDSHV1_MCU		PWR									
T30, T32, U31	VDDSHV2	VDDSHV2		PWR									
H27, J26, K27	VDDSHV2_MCU	VDDSHV2_MCU		PWR									
P31, R30, R31	VDDSHV5	VDDSHV5		PWR									
A31, AK1, B1, H11, H13, H15, H17, H19, H9, J10, J12, J14, J16, J18, J8, K11, K13, K15, K17, K19, K9, L10, L12, L14, L16, L18, M9, N10, N8, P9, R10, R8, T9, U10, U8	VDDS_DDR	VDDS_DDR		PWR									
T10	VDDS_DDR_C0	VDDS_DDR_C0		PWR									
L15	VDDS_DDR_C1	VDDS_DDR_C1		PWR									
M10	VDDS_DDR_C2	VDDS_DDR_C2		PWR									
L17	VDDS_DDR_C3	VDDS_DDR_C3		PWR									
AF9, AG10, AG8, AH9	VDDS_MMC0	VDDS_MMC0		PWR									

**ADVANCE INFORMATION**

**表 6-1. Pin Attributes (ALY Package) (continued)**

Ball Num [1]	Ball Name [2] PADCFG Register [15] PADCFG Address [16]	Signal Name [3]	Mux Mode [4]	Signal Type [5]	I/O Voltage [6]	Ball State DURING Reset (RX/TX/PULL) [7]	Ball State AFTER Reset (RX/TX/PULL) [8]	Mux Mode AFTER Reset [9]	Pull Type [10]	Power [11]	Hys [12]	Voltage Buffer Type [13]	IO RET [14]
AA24, AA26, AA28, AA30, AB25, AB29, AB31, AC26, AC28, AC30, AD25, AD27, AD29, AD31, AE24, AE26, AE28, AE30, AE32, AF13, AF17, AF19, AF23, AF25, AF27, AF29, AF31, AG12, AG14, AG16, AG18, AG20, AG22, AG24, AG26, AG30, AG32, AH31, AJ30, M11, M13, M15, M17, M19, N12, N16, N18, P11, P17, P19, R12, R14, R16, R18, R24, R26, R28, T11, T13, T27, U12, U24, U26, U28, V25, V27, W24, W26, W28, W30, W32, Y25, Y29, Y31	VDD_CORE	VDD_CORE		PWR									

**ADVANCE INFORMATION**

**表 6-1. Pin Attributes (ALY Package) (continued)**

Ball Num [1]	Ball Name [2] PADCFG Register [15] PADCFG Address [16]	Signal Name [3]	Mux Mode [4]	Signal Type [5]	I/O Voltage [6]	Ball State DURING Reset (RX/TX/PULL) [7]	Ball State AFTER Reset (RX/TX/PULL) [8]	Mux Mode AFTER Reset [9]	Pull Type [10]	Power [11]	Hys [12]	Voltage Buffer Type [13]	IO RET [14]
AA10, AA12, AA14, AA20, AA22, AA8, AB11, AB19, AB21, AB23, AB9, AC10, AC12, AC14, AC22, AD11, AD13, AD15, AD17, AD19, AD21, AD23, AD9, AE10, AE14, AE16, AE18, AE20, AE22, AF11, H21, H23, J20, J22, K21, K23, L20, L22, N20, N22, P21, R20, R22, T17, T19, T21, T23, U14, U22, V11, V13, V19, V21, V23, V9, W10, W12, W20, W22, W8, Y13, Y21, Y23, Y9	VDD_CPU	VDD_CPU		PWR									
L24, M23, M25, N26, P23, P25, P27	VDD_MCU	VDD_MCU		PWR									
L28	VDD_MCU_WAKE1	VDD_MCU_WAKE1		PWR									
U29	VDD_WAKE0	VDD_WAKE0		PWR									
K28	VMON1_ER_VSYS	VMON1_ER_VSYS											
N27	VMON2_IR_VCPU	VMON2_IR_VCPU											
J30	VMON3_IR_VEXT1P8	VMON3_IR_VEXT1P8											
P28	VMON4_IR_VEXT1P8	VMON4_IR_VEXT1P8											
R29	VMON5_IR_VEXT3P3	VMON5_IR_VEXT3P3											
AA31	VPP_CORE	VPP_CORE											
L29	VPP_MCU	VPP_MCU											

ADVANCE INFORMATION

**表 6-1. Pin Attributes (ALY Package) (continued)**

Ball Num [1]	Ball Name [2] PADCFG Register [15] PADCFG Address [16]	Signal Name [3]	Mux Mode [4]	Signal Type [5]	I/O Voltage [6]	Ball State DURING Reset (RX/TX/PULL) [7]	Ball State AFTER Reset (RX/TX/PULL) [8]	Mux Mode AFTER Reset [9]	Pull Type [10]	Power [11]	Hys [12]	Voltage Buffer Type [13]	IO RET [14]
A1, A10, A12, A15, A2, A20, A23, A25, A28, A34, A37, A5, A7, AA11, AA13, AA19, AA2, AA21, AA25, AA29, AA34, AA36, AA38, AA5, AA9, AB1, AB10, AB12, AB14, AB20, AB22, AB24, AB28, AB30, AB32, AB33, AB35, AB37, AB5, AB8, AC11, AC13, AC15, AC17, AC19, AC2, AC21, AC23, AC25, AC27, AC29, AC31, AC6, AC9, AD1, AD10, AD12, AD14, AD16, AD20, AD22, AD24, AD26, AD28, AD30, AD32, AD35, AD4, AD8, AE11, AE15, AE17, AE19, AE2, AE21, AE23, AE25, AE27, AE29, AE31, AE5, AF10, AF12, AF14, AF16, AF20, AF22, AF24, AF26, AF28, AF3, AF30, AF32, AF6, AF8, AG1, AG15,	VSS	VSS		GND									

**ADVANCE INFORMATION**

**表 6-1. Pin Attributes (ALY Package) (continued)**

Ball Num [1]	Ball Name [2] PADCFG Register [15] PADCFG Address [16]	Signal Name [3]	Mux Mode [4]	Signal Type [5]	I/O Voltage [6]	Ball State DURING Reset (RX/TX/PULL) [7]	Ball State AFTER Reset (RX/TX/PULL) [8]	Mux Mode AFTER Reset [9]	Pull Type [10]	Power [11]	Hys [12]	Voltage Buffer Type [13]	IO RET [14]
AG19, AG25, AG27, AG29, AG31, AG4, AG7, AG9, AH10, AH14, AH19, AH2, AH22, AH23, AH26, AH30, AH32, AH35, AH5, AH8, AJ11, AJ16, AJ22, AJ27, AJ3, AJ31, AJ6, AJ8, AJ9, AK10, AK11, AK12, AK15, AK16, AK17, AK18, AK19, AK22, AK23, AK24, AK25, AK27, AK28, AK30, AK32, AL1, AL10, AL12, AL13, AL14, AL15, AL16, AL17, AL18, AL19, AL21, AL26, AL29, AL31, AL4, AM11, AM13, AM15, AM18, AM20, AM23, AM25, AM27, AM3, AM30, AM32, AM38, AM6, AN1, AN10, AN12, AN14, AN16, AN19, AN22, AN25, AN28, AN31, AN34, AN4, AN7, AP12, AP15, AP18,													

**ADVANCE INFORMATION**



**表 6-1. Pin Attributes (ALY Package) (continued)**

Ball Num [1]	Ball Name [2] PADCFG Register [15] PADCFG Address [16]	Signal Name [3]	Mux Mode [4]	Signal Type [5]	I/O Voltage [6]	Ball State DURING Reset (RX/TX/PULL) [7]	Ball State AFTER Reset (RX/TX/PULL) [8]	Mux Mode AFTER Reset [9]	Pull Type [10]	Power [11]	Hys [12]	Voltage Buffer Type [13]	IO RET [14]
AP21, AP24, AP27, AP3, AP30, AP33, AP36, AP6, AP9, AR1, AR10, AR13, AR16, AR19, AR22, AR25, AR28, AR31, AR34, AR37, AR4, AR7, AT12, AT15, AT18, AT21, AT24, AT27, AT3, AT30, AT33, AT36, AT6, AT9, AU1, AU10, AU13, AU16, AU19, AU22, AU25, AU28, AU31, AU34, AU37, AU38, AU4, AU7, AV1, AV11, AV14, AV17, AV2, AV20, AV23, AV26, AV29, AV32, AV35, AV5, AV8, B11, B13, B16, B19, B22, B24, B26, B29, B31, B38, B6, B9, C14, C17, C18, C2, C21, C27, C30, C4, C8, D10, D15, D20, D23, D28, D3, D35, D6, D7, E12, E13, E16, E19, E2, E22, E25,													

**ADVANCE INFORMATION**

**表 6-1. Pin Attributes (ALY Package) (continued)**

Ball Num [1]	Ball Name [2] PADCFG Register [15] PADCFG Address [16]	Signal Name [3]	Mux Mode [4]	Signal Type [5]	I/O Voltage [6]	Ball State DURING Reset (RX/TX/PULL) [7]	Ball State AFTER Reset (RX/TX/PULL) [8]	Mux Mode AFTER Reset [9]	Pull Type [10]	Power [11]	Hys [12]	Voltage Buffer Type [13]	IO RET [14]
E26, E29, E31, E5, E9, F1, F11, F14, F17, F21, F24, F27, F30, F4, F7, F8, G15, G18, G20, G28, G3, G6, H10, H16, H18, H2, H20, H22, H24, H26, H28, H30, H31, H5, H7, H8, J1, J11, J13, J15, J17, J19, J21, J23, J25, J27, J29, J32, J4, J9, K10, K12, K14, K16, K18, K2, K20, K22, K24, K26, K6, K8, L1, L11, L13, L19, L21, L23, L31, L5, L9, M16, M2, M20, M22, M24, M29, M30, M32, M5, M8, N15, N17, N19, N21, N25, N3, N31, N32, N38, N6, N9, P1, P10, P16, P18, P20, P22, P24, P26, P30, P32, P35, P37, P4, P7, P8, R11, R13, R15, R17, R19, R2, R23, R25, R27, R32, R34, R36, R38, R5, R9, T12, T14, T16,													

**ADVANCE INFORMATION**

**表 6-1. Pin Attributes (ALY Package) (continued)**

Ball Num [1]	Ball Name [2] PADCFG Register [15] PADCFG Address [16]	Signal Name [3]	Mux Mode [4]	Signal Type [5]	I/O Voltage [6]	Ball State DURING Reset (RX/TX/PULL) [7]	Ball State AFTER Reset (RX/TX/PULL) [8]	Mux Mode AFTER Reset [9]	Pull Type [10]	Power [11]	Hys [12]	Voltage Buffer Type [13]	IO RET [14]
T18, T20, T22, T24, T26, T28, T3, T31, T33, T35, T37, T6, T8, U13, U19, U21, U23, U25, U27, U3, U30, U32, U34, U36, U38, U6, U9, V10, V12, V2, V20, V22, V24, V26, V28, V31, V33, V35, V37, V5, V8, W1, W11, W13, W19, W25, W27, W29, W34, W36, W38, W4, W7, W9, Y10, Y12, Y14, Y20, Y22, Y24, Y3, Y30, Y32, Y33, Y35, Y37, Y6, Y8													
H38	WKUP_GPIO0_0 PADCFG: WKUP_PADCONFIG_48 0x4301C0C0	MCU_SPI1_CLK	0	IO	1.8 V/3.3 V	On / Off / Off	On / Off / Off	7	PU/PD	VDDSHV0_MCU	Yes	LVCMOS	Yes
		MCU_SPI1_CLK	1	IO									
		WKUP_GPIO0_0	7	IO									
		MCU_BOOTMODE03	BOOTS TRAP	I									
J34	WKUP_GPIO0_1 PADCFG: WKUP_PADCONFIG_49 0x4301C0C4	MCU_SPI1_D0	0	IO	1.8 V/3.3 V	On / Off / Off	On / Off / Off	7	PU/PD	VDDSHV0_MCU	Yes	LVCMOS	Yes
		MCU_SPI1_D0	1	IO									
		WKUP_GPIO0_1	7	IO									
		MCU_BOOTMODE04	BOOTS TRAP	I									
J35	WKUP_GPIO0_2 PADCFG: WKUP_PADCONFIG_50 0x4301C0C8	MCU_SPI1_D1	0	IO	1.8 V/3.3 V	On / Off / Off	On / Off / Off	7	PU/PD	VDDSHV0_MCU	Yes	LVCMOS	Yes
		MCU_SPI1_D1	1	IO									
		WKUP_GPIO0_2	7	IO									
		MCU_BOOTMODE05	BOOTS TRAP	I									

ADVANCE INFORMATION

**表 6-1. Pin Attributes (ALY Package) (continued)**

Ball Num [1]	Ball Name [2] PADCFG Register [15] PADCFG Address [16]	Signal Name [3]	Mux Mode [4]	Signal Type [5]	I/O Voltage [6]	Ball State DURING Reset (RX/TX/PULL) [7]	Ball State AFTER Reset (RX/TX/PULL) [8]	Mux Mode AFTER Reset [9]	Pull Type [10]	Power [11]	Hys [12]	Voltage Buffer Type [13]	IO RET [14]
J36	WKUP_GPIO0_3 PADCFG: WKUP_PADCONFIG_51 0x4301C0CC	MCU_SPI1_CS0	0	IO	1.8 V/3.3 V	Off / Off / Off	Off / Off / Off	7	PU/PD	VDDSHV0_MCU	Yes	LVCMOS	Yes
		MCU_SPI1_CS0	1	IO									
		WKUP_GPIO0_3	7	IO									
H35	WKUP_GPIO0_4 PADCFG: WKUP_PADCONFIG_52 0x4301C0D0	MCU_MCAN1_TX	0	O	1.8 V/3.3 V	Off / Off / Off	Off / Off / Off	7	PU/PD	VDDSHV0_MCU	Yes	LVCMOS	Yes
		MCU_MCAN1_TX	1	O									
		MCU_SPI0_CS3	2	IO									
		MCU_ADC_EXT_TRIGGER0	3	I									
K36	WKUP_GPIO0_5 PADCFG: WKUP_PADCONFIG_53 0x4301C0D4	MCU_MCAN1_RX	0	I	1.8 V/3.3 V	Off / Off / Off	Off / Off / Off	7	PU/PD	VDDSHV0_MCU	Yes	LVCMOS	Yes
		MCU_MCAN1_RX	1	I									
		MCU_SPI1_CS3	2	IO									
		MCU_ADC_EXT_TRIGGER1	3	I									
		WKUP_GPIO0_5	7	IO									
L37	WKUP_GPIO0_6 PADCFG: WKUP_PADCONFIG_54 0x4301C0D8	WKUP_UART0_CTSn	0	I	1.8 V/3.3 V	Off / Off / Off	Off / Off / Off	7	PU/PD	VDDSHV0_MCU	Yes	LVCMOS	Yes
		WKUP_UART0_CTSn	1	I									
		MCU_CPTS0_HW1TSPUSH	2	I									
		MCU_I2C1_SCL	3	IOD									
L36	WKUP_GPIO0_7 PADCFG: WKUP_PADCONFIG_55 0x4301C0DC	WKUP_UART0_RTSn	0	O	1.8 V/3.3 V	Off / Off / Off	Off / Off / Off	7	PU/PD	VDDSHV0_MCU	Yes	LVCMOS	Yes
		WKUP_UART0_RTSn	1	O									
		MCU_CPTS0_HW2TSPUSH	2	I									
		MCU_I2C1_SDA	3	IOD									
		WKUP_GPIO0_7	7	IO									
L35	WKUP_GPIO0_8 PADCFG: WKUP_PADCONFIG_56 0x4301C0E0	MCU_I2C1_SCL	0	IOD	1.8 V/3.3 V	Off / Off / Off	Off / Off / Off	7	PU/PD	VDDSHV0_MCU	Yes	LVCMOS	Yes
		MCU_I2C1_SCL	1	IOD									
		MCU_CPTS0_TS_SYNC	2	O									
		MCU_I3C0_SCL	3	IO									
		MCU_TIMER_IO6	4	IO									
WKUP_GPIO0_8	7	IO											
L34	WKUP_GPIO0_9 PADCFG: WKUP_PADCONFIG_57 0x4301C0E4	MCU_I2C1_SDA	0	IOD	1.8 V/3.3 V	Off / Off / Off	Off / Off / Off	7	PU/PD	VDDSHV0_MCU	Yes	LVCMOS	Yes
		MCU_I2C1_SDA	1	IOD									
		MCU_CPTS0_TS_COMP	2	O									
		MCU_I3C0_SDA	3	IO									
		MCU_TIMER_IO7	4	IO									
WKUP_GPIO0_9	7	IO											

ADVANCE INFORMATION

**表 6-1. Pin Attributes (ALY Package) (continued)**

Ball Num [1]	Ball Name [2] PADCFG Register [15] PADCFG Address [16]	Signal Name [3]	Mux Mode [4]	Signal Type [5]	I/O Voltage [6]	Ball State DURING Reset (RX/TX/PULL) [7]	Ball State AFTER Reset (RX/TX/PULL) [8]	Mux Mode AFTER Reset [9]	Pull Type [10]	Power [11]	Hys [12]	Voltage Buffer Type [13]	IO RET [14]
L33	WKUP_GPIO0_10 PADCFG: WKUP_PADCONFIG_58 0x4301C0E8	MCU_EXT_REFCLK0	0	I	1.8 V/3.3 V	Off / Off / Off	Off / Off / Off	7	PU/PD	VDDSHV0_MCU	Yes	LVC MOS	Yes
		MCU_EXT_REFCLK0	1	I									
		MCU_UART0_TXD	2	O									
		MCU_ADC_EXT_TRIGGER0	3	I									
		MCU_CPTS0_RFT_CLK	4	I									
		MCU_SYSCLKOUT0	5	O									
M38	WKUP_GPIO0_11 PADCFG: WKUP_PADCONFIG_59 0x4301C0EC	MCU_OBSCLK0	0	O	1.8 V/3.3 V	Off / Off / Off	Off / Off / Off	7	PU/PD	VDDSHV0_MCU	Yes	LVC MOS	Yes
		MCU_OBSCLK0	1	O									
		MCU_UART0_RXD	2	I									
		MCU_ADC_EXT_TRIGGER1	3	I									
		MCU_TIMER_IO1	4	IO									
		MCU_I3C0_SDAPULLEN	5	OD									
		MCU_CLKOUT0	6	OZ									
WKUP_GPIO0_11	7	IO											
J37	WKUP_GPIO0_12 PADCFG: WKUP_PADCONFIG_60 0x4301C0F0	MCU_UART0_TXD	0	O	1.8 V/3.3 V	On / Off / Off	On / Off / Off	7	PU/PD	VDDSHV0_MCU	Yes	LVC MOS	Yes
		MCU_SPI0_CS1	1	IO									
		WKUP_GPIO0_12	7	IO									
		MCU_BOOTMODE08	BOOTS TRAP	I									
K38	WKUP_GPIO0_13 PADCFG: WKUP_PADCONFIG_61 0x4301C0F4	MCU_UART0_RXD	0	I	1.8 V/3.3 V	On / Off / Off	On / Off / Off	7	PU/PD	VDDSHV0_MCU	Yes	LVC MOS	Yes
		MCU_SPI1_CS1	1	IO									
		WKUP_GPIO0_13	7	IO									
		MCU_BOOTMODE09	BOOTS TRAP	I									
H37	WKUP_GPIO0_14 PADCFG: WKUP_PADCONFIG_62 0x4301C0F8	MCU_UART0_CTSn	0	I	1.8 V/3.3 V	On / Off / Off	On / Off / Off	7	PU/PD	VDDSHV0_MCU	Yes	LVC MOS	Yes
		MCU_SPI0_CS2	1	IO									
		MCU_TIMER_IO8	4	IO									
		WKUP_GPIO0_14	7	IO									
		MCU_BOOTMODE06	BOOTS TRAP	I									
K37	WKUP_GPIO0_15 PADCFG: WKUP_PADCONFIG_63 0x4301C0FC	MCU_UART0_RTSn	0	O	1.8 V/3.3 V	On / Off / Off	On / Off / Off	7	PU/PD	VDDSHV0_MCU	Yes	LVC MOS	Yes
		MCU_SPI1_CS2	1	IO									
		MCU_TIMER_IO9	4	IO									
		WKUP_GPIO0_15	7	IO									
		MCU_BOOTMODE07	BOOTS TRAP	I									

**ADVANCE INFORMATION**

**表 6-1. Pin Attributes (ALY Package) (continued)**

Ball Num [1]	Ball Name [2] PADCFG Register [15] PADCFG Address [16]	Signal Name [3]	Mux Mode [4]	Signal Type [5]	I/O Voltage [6]	Ball State DURING Reset (RX/TX/PULL) [7]	Ball State AFTER Reset (RX/TX/PULL) [8]	Mux Mode AFTER Reset [9]	Pull Type [10]	Power [11]	Hys [12]	Voltage Buffer Type [13]	IO RET [14]
M33	WKUP_GPIO0_49 PADCFG: WKUP_PADCONFIG_100 0x4301C190	PMIC_WAKE1n	0	O	1.8 V/3.3 V	Off / Off / Off	Off / Off / Off	7	PU/PD	VDDSHV0_M CU	Yes	LVCMOS	No
		MCU_EXT_REFCLK0	1	I									
		MCU_CPTS0_RFT_CLK	2	I									
		WKUP_GPIO0_49	7	IO									
M37	WKUP_GPIO0_56 PADCFG: WKUP_PADCONFIG_72 0x4301C120	MCU_TIMER_IO6	4	IO	1.8 V/3.3 V	On / Off / Off	On / Off / Off	7	PU/PD	VDDSHV0_M CU	Yes	LVCMOS	No
		WKUP_GPIO0_56	7	IO									
		BOOTMODE04	BOOTS TRAP	I									
M36	WKUP_GPIO0_57 PADCFG: WKUP_PADCONFIG_95 0x4301C17C	MCU_TIMER_IO7	4	IO	1.8 V/3.3 V	On / Off / Off	On / Off / Off	7	PU/PD	VDDSHV0_M CU	Yes	LVCMOS	No
		WKUP_GPIO0_57	7	IO									
		BOOTMODE05	BOOTS TRAP	I									
N34	WKUP_GPIO0_66 PADCFG: WKUP_PADCONFIG_96 0x4301C180	WKUP_GPIO0_66	7	IO	1.8 V/3.3 V	On / Off / Off	On / Off / Off	7	PU/PD	VDDSHV0_M CU	Yes	LVCMOS	Yes
		BOOTMODE06	BOOTS TRAP	I									
M34	WKUP_GPIO0_67 PADCFG: WKUP_PADCONFIG_97 0x4301C184	WKUP_LF_CLKIN	1	I	1.8 V/3.3 V	On / Off / Off	On / Off / Off	7	PU/PD	VDDSHV0_M CU	Yes	LVCMOS	Yes
		WKUP_GPIO0_67	7	IO									
		BOOTMODE07	BOOTS TRAP	I									
N33	WKUP_I2C0_SCL PADCFG: WKUP_PADCONFIG_64 0x4301C100	WKUP_I2C0_SCL	0	IOD	1.8 V/3.3 V	Off / Off / Off	On / SS / Off	0		VDDSHV0_M CU	Yes	I2C OPEN DRAIN	Yes
		WKUP_GPIO0_63	7	IO									
N35	WKUP_I2C0_SDA PADCFG: WKUP_PADCONFIG_65 0x4301C104	WKUP_I2C0_SDA	0	IOD	1.8 V/3.3 V	Off / Off / Off	On / SS / Off	0		VDDSHV0_M CU	Yes	I2C OPEN DRAIN	Yes
		WKUP_GPIO0_64	7	IO									
T38	WKUP_OSC0_XI	WKUP_OSC0_XI		I	1.8 V					VDDA_WKUP	Yes	HFXOSC	No
U37	WKUP_OSC0_XO	WKUP_OSC0_XO		O	1.8 V					VDDA_WKUP	Yes	HFXOSC	No
K35	WKUP_UART0_RXD PADCFG: WKUP_PADCONFIG_44 0x4301C0B0	WKUP_UART0_RXD	0	I	1.8 V/3.3 V	Off / Off / Off	Off / Off / Off	7	PU/PD	VDDSHV0_M CU	Yes	LVCMOS	Yes
		WKUP_GPIO0_58	7	IO									
K34	WKUP_UART0_TXD PADCFG: WKUP_PADCONFIG_45 0x4301C0B4	WKUP_UART0_TXD	0	O	1.8 V/3.3 V	Off / Off / Off	Off / Off / Off	7	PU/PD	VDDSHV0_M CU	Yes	LVCMOS	Yes
		WKUP_GPIO0_59	7	IO									

## 6.3 Signal Descriptions

1. **SIGNAL NAME:** The name of the signal passing through the pin.

### 注

Signal names and descriptions provided in each Signal Descriptions table, represent the pin multiplexed signal function which is implemented at the pin and selected via PADCONFIG registers. Device subsystems may provide secondary multiplexing of signal functions, which are not described in these tables. For more information on secondary multiplexed signal functions, see the respective peripheral chapter of the device TRM.

2. **PIN TYPE:** Signal direction and type:

- I = Input
- O = Output
- OD = Output, with open-drain output function
- IO = Input, Output, or simultaneously Input and Output
- IOD = Input, Output, or simultaneously Input and Output with open-drain output function
- IOZ = Input, Output, or simultaneously Input and Output with three-state output function
- OZ = Output with three-state output function
- A = Analog
- PWR = Power
- GND = Ground
- CAP = LDO Capacitor

3. **DESCRIPTION:** Description of the signal

4. **BALL:** Ball number(s) associated with signal

For more information on the IO cell configurations, see the *Pad Configuration Registers* section in *Device Configuration* chapter of the device TRM.

### 6.3.1 ADC

#### 6.3.1.1 MCU Domain

表 6-2. MCU\_ADC Signal Descriptions

SIGNAL NAME [1]	PIN TYPE [2]	DESCRIPTION [3]	ALY PIN [4]
MCU_ADC_EXT_TRIGGER0	I	ADC Trigger Input	E38, H35, L33
MCU_ADC_EXT_TRIGGER1	I	ADC Trigger Input	E37, K36, M38

表 6-3. MCU\_ADC0 Signal Descriptions

SIGNAL NAME [1]	PIN TYPE [2]	DESCRIPTION [3]	ALY PIN [4]
MCU_ADC0_REFN	A	ADC Reference (Negative)	U35
MCU_ADC0_REFP	A	ADC Reference (Positive)	R35
MCU_ADC0_AIN0	A	ADC Input 0	P36
MCU_ADC0_AIN1	A	ADC Input 1	V36
MCU_ADC0_AIN2	A	ADC Input 2	T34
MCU_ADC0_AIN3	A	ADC Input 3	T36
MCU_ADC0_AIN4	A	ADC Input 4	P34
MCU_ADC0_AIN5	A	ADC Input 5	R37
MCU_ADC0_AIN6	A	ADC Input 6	R33
MCU_ADC0_AIN7	A	ADC Input 7	V38

**表 6-4. MCU\_ADC1 Signal Descriptions**

SIGNAL NAME [1]	PIN TYPE [2]	DESCRIPTION [3]	ALY PIN [4]
MCU_ADC1_REFN	A	ADC Reference (Negative)	W35
MCU_ADC1_REFP	A	ADC Reference (Positive)	AA35
MCU_ADC1_AIN0	A	ADC Input 0	Y38
MCU_ADC1_AIN1	A	ADC Input 1	Y34
MCU_ADC1_AIN2	A	ADC Input 2	V34
MCU_ADC1_AIN3	A	ADC Input 3	W37
MCU_ADC1_AIN4	A	ADC Input 4	AA37
MCU_ADC1_AIN5	A	ADC Input 5	W33
MCU_ADC1_AIN6	A	ADC Input 6	U33
MCU_ADC1_AIN7	A	ADC Input 7	Y36

## 6.3.2 DDRSS

### 6.3.2.1 MAIN Domain

**表 6-5. DDRSS0 Signal Descriptions**

SIGNAL NAME [1] (2)	PIN TYPE [2]	DESCRIPTION [3]	ALY PIN [4]
DDR0_CKN	IO	DDRSS Differential Clock (negative)	AB2
DDR0_CKP	IO	DDRSS Differential Clock (positive)	AC1
DDR0_RESETh	IO	DDRSS Reset	AD5
DDR0_RET	I	DDR Retention Enable	AC8
DDR0_CA0	IO	DDRSS Command Address	AD2
DDR0_CA1	IO	DDRSS Command Address	AC5
DDR0_CA2	IO	DDRSS Command Address	AB4
DDR0_CA3	IO	DDRSS Command Address	AC4
DDR0_CA4	IO	DDRSS Command Address	AB3
DDR0_CA5	IO	DDRSS Command Address	AC3
DDR0_CAL0 (1)	A	IO Pad Calibration Resistor	AE8
DDR0_CKE0	IO	DDRSS Clock Enable	AB6
DDR0_CKE1	IO	DDRSS Clock Enable	AD3
DDR0_CSn0_0	IO	DDRSS Chip Select	AD7
DDR0_CSn0_1	IO	DDRSS Chip Select	AC7
DDR0_CSn1_0	IO	DDRSS Chip Select	AB7
DDR0_CSn1_1	IO	DDRSS Chip Select	AD6
DDR0_DM0	IO	DDRSS Data Mask	V3
DDR0_DM1	IO	DDRSS Data Mask	AA4
DDR0_DM2	IO	DDRSS Data Mask	AG2
DDR0_DM3	IO	DDRSS Data Mask	AJ5
DDR0_DQ0	IO	DDRSS Data	U2
DDR0_DQ1	IO	DDRSS Data	U4
DDR0_DQ2	IO	DDRSS Data	W6
DDR0_DQ3	IO	DDRSS Data	W5
DDR0_DQ4	IO	DDRSS Data	V4
DDR0_DQ5	IO	DDRSS Data	V7
DDR0_DQ6	IO	DDRSS Data	U5
DDR0_DQ7	IO	DDRSS Data	V6
DDR0_DQ8	IO	DDRSS Data	Y2



**表 6-5. DDRSS0 Signal Descriptions (continued)**

SIGNAL NAME [1] <sup>(2)</sup>	PIN TYPE [2]	DESCRIPTION [3]	ALY PIN [4]
DDR0_DQ9	IO	DDRSS Data	W3
DDR0_DQ10	IO	DDRSS Data	AA3
DDR0_DQ11	IO	DDRSS Data	W2
DDR0_DQ12	IO	DDRSS Data	AA6
DDR0_DQ13	IO	DDRSS Data	Y4
DDR0_DQ14	IO	DDRSS Data	Y5
DDR0_DQ15	IO	DDRSS Data	AA7
DDR0_DQ16	IO	DDRSS Data	AF2
DDR0_DQ17	IO	DDRSS Data	AE7
DDR0_DQ18	IO	DDRSS Data	AG3
DDR0_DQ19	IO	DDRSS Data	AF5
DDR0_DQ20	IO	DDRSS Data	AE6
DDR0_DQ21	IO	DDRSS Data	AF4
DDR0_DQ22	IO	DDRSS Data	AE3
DDR0_DQ23	IO	DDRSS Data	AE4
DDR0_DQ24	IO	DDRSS Data	AG5
DDR0_DQ25	IO	DDRSS Data	AH3
DDR0_DQ26	IO	DDRSS Data	AJ2
DDR0_DQ27	IO	DDRSS Data	AH4
DDR0_DQ28	IO	DDRSS Data	AJ4
DDR0_DQ29	IO	DDRSS Data	AH6
DDR0_DQ30	IO	DDRSS Data	AH7
DDR0_DQ31	IO	DDRSS Data	AG6
DDR0_QS0N	IO	DDRSS Complimentary Data Strobe	V1
DDR0_QS0P	IO	DDRSS Data Strobe	U1
DDR0_QS1N	IO	DDRSS Complimentary Data Strobe	Y1
DDR0_QS1P	IO	DDRSS Data Strobe	AA1
DDR0_QS2N	IO	DDRSS Complimentary Data Strobe	AE1
DDR0_QS2P	IO	DDRSS Data Strobe	AF1
DDR0_QS3N	IO	DDRSS Complimentary Data Strobe	AH1
DDR0_QS3P	IO	DDRSS Data Strobe	AJ1

- (1) An external 240 Ω ±1% resistor must be connected between this pin and VSS. No external voltage should be applied to this pin.  
(2) DDRSS0, DDRSS1, DDRSS2, and DDRSS3 must always be used in incremental order. For instance, when using a single LPDDR component, it must be connected to the DDR0\_\* interface. When using two LPDDR components, they must be connected to DDR0\_\* and DDR1\_\* interfaces, and so forth.

**表 6-6. DDRSS1 Signal Descriptions**

SIGNAL NAME [1] <sup>(2)</sup>	PIN TYPE [2]	DESCRIPTION [3]	ALY PIN [4]
DDR1_CKN	IO	DDRSS Differential Clock (negative)	A11
DDR1_CKP	IO	DDRSS Differential Clock (positive)	B10
DDR1_RESETh	IO	DDRSS Reset	G10
DDR1_RET	I	DDR Retention Enable	G8
DDR1_CA0	IO	DDRSS Command Address	F12
DDR1_CA1	IO	DDRSS Command Address	C12
DDR1_CA2	IO	DDRSS Command Address	B12
DDR1_CA3	IO	DDRSS Command Address	C11

**表 6-6. DDRSS1 Signal Descriptions (continued)**

SIGNAL NAME [1] <sup>(2)</sup>	PIN TYPE [2]	DESCRIPTION [3]	ALY PIN [4]
DDR1_CA4	IO	DDRSS Command Address	D12
DDR1_CA5	IO	DDRSS Command Address	E10
DDR1_CAL0 <sup>(1)</sup>	A	IO Pad Calibration Resistor	G14
DDR1_CKE0	IO	DDRSS Clock Enable	D11
DDR1_CKE1	IO	DDRSS Clock Enable	C10
DDR1_CSn0_0	IO	DDRSS Chip Select	E11
DDR1_CSn0_1	IO	DDRSS Chip Select	G11
DDR1_CSn1_0	IO	DDRSS Chip Select	F10
DDR1_CSn1_1	IO	DDRSS Chip Select	G12
DDR1_DM0	IO	DDRSS Data Mask	E17
DDR1_DM1	IO	DDRSS Data Mask	C15
DDR1_DM2	IO	DDRSS Data Mask	D8
DDR1_DM3	IO	DDRSS Data Mask	C1
DDR1_DQ0	IO	DDRSS Data	F16
DDR1_DQ1	IO	DDRSS Data	G16
DDR1_DQ2	IO	DDRSS Data	F15
DDR1_DQ3	IO	DDRSS Data	E15
DDR1_DQ4	IO	DDRSS Data	D16
DDR1_DQ5	IO	DDRSS Data	C16
DDR1_DQ6	IO	DDRSS Data	B17
DDR1_DQ7	IO	DDRSS Data	D17
DDR1_DQ8	IO	DDRSS Data	B15
DDR1_DQ9	IO	DDRSS Data	B14
DDR1_DQ10	IO	DDRSS Data	C13
DDR1_DQ11	IO	DDRSS Data	D13
DDR1_DQ12	IO	DDRSS Data	F13
DDR1_DQ13	IO	DDRSS Data	G13
DDR1_DQ14	IO	DDRSS Data	E14
DDR1_DQ15	IO	DDRSS Data	D14
DDR1_DQ16	IO	DDRSS Data	E8
DDR1_DQ17	IO	DDRSS Data	G9
DDR1_DQ18	IO	DDRSS Data	F9
DDR1_DQ19	IO	DDRSS Data	D9
DDR1_DQ20	IO	DDRSS Data	C9
DDR1_DQ21	IO	DDRSS Data	B8
DDR1_DQ22	IO	DDRSS Data	B7
DDR1_DQ23	IO	DDRSS Data	C7
DDR1_DQ24	IO	DDRSS Data	B2
DDR1_DQ25	IO	DDRSS Data	B3
DDR1_DQ26	IO	DDRSS Data	B4
DDR1_DQ27	IO	DDRSS Data	B5
DDR1_DQ28	IO	DDRSS Data	A6
DDR1_DQ29	IO	DDRSS Data	C5
DDR1_DQ30	IO	DDRSS Data	C6
DDR1_DQ31	IO	DDRSS Data	C3

ADVANCE INFORMATION

**表 6-6. DDRSS1 Signal Descriptions (continued)**

SIGNAL NAME [1] <sup>(2)</sup>	PIN TYPE [2]	DESCRIPTION [3]	ALY PIN [4]
DDR1_DQS0N	IO	DDRSS Complimentary Data Strobe	A17
DDR1_DQS0P	IO	DDRSS Data Strobe	A16
DDR1_DQS1N	IO	DDRSS Complimentary Data Strobe	A14
DDR1_DQS1P	IO	DDRSS Data Strobe	A13
DDR1_DQS2N	IO	DDRSS Complimentary Data Strobe	A9
DDR1_DQS2P	IO	DDRSS Data Strobe	A8
DDR1_DQS3N	IO	DDRSS Complimentary Data Strobe	A4
DDR1_DQS3P	IO	DDRSS Data Strobe	A3

- (1) An external 240 Ω ±1% resistor must be connected between this pin and VSS. No external voltage should be applied to this pin.  
 (2) DDRSS0, DDRSS1, DDRSS2, and DDRSS3 must always be used in incremental order. For instance, when using a single LPDDR component, it must be connected to the DDR0\_\* interface. When using two LPDDR components, they must be connected to DDR0\_\* and DDR1\_\* interfaces, and so forth.

**表 6-7. DDRSS2 Signal Descriptions**

SIGNAL NAME [1] <sup>(2)</sup> <sup>(3)</sup>	PIN TYPE [2]	DESCRIPTION [3]	ALY PIN [4]
DDR2_CKN	IO	DDRSS Differential Clock (negative)	K1
DDR2_CKP	IO	DDRSS Differential Clock (positive)	L2
DDR2_RESETn	IO	DDRSS Reset	J5
DDR2_RET	I	DDR Retention Enable	L8
DDR2_CA0	IO	DDRS Command Address	K3
DDR2_CA1	IO	DDRS Command Address	L3
DDR2_CA2	IO	DDRS Command Address	K5
DDR2_CA3	IO	DDRS Command Address	L4
DDR2_CA4	IO	DDRS Command Address	K4
DDR2_CA5	IO	DDRS Command Address	L7
DDR2_CAL0 <sup>(1)</sup>	A	DDRSS IO Pad Calibration Resistor	U7
DDR2_CKE0	IO	DDR Clock Enable	L6
DDR2_CKE1	IO	DDR Clock Enable	J2
DDR2_CSn0_0	IO	DDRSS Chip Select	J3
DDR2_CSn0_1	IO	DDRSS Chip Select	J6
DDR2_CSn1_0	IO	DDRSS Chip Select	J7
DDR2_CSn1_1	IO	DDRSS Chip Select	K7
DDR2_DM0	IO	DDRSS Data Mask	T2
DDR2_DM1	IO	DDRSS Data Mask	M6
DDR2_DM2	IO	DDRSS Data Mask	G4
DDR2_DM3	IO	DDRSS Data Mask	D5
DDR2_DQ0	IO	DDRSS Data	T4
DDR2_DQ1	IO	DDRSS Data	R6
DDR2_DQ2	IO	DDRSS Data	R3
DDR2_DQ3	IO	DDRSS Data	R4
DDR2_DQ4	IO	DDRSS Data	P6
DDR2_DQ5	IO	DDRSS Data	P5
DDR2_DQ6	IO	DDRSS Data	T5
DDR2_DQ7	IO	DDRSS Data	R7
DDR2_DQ8	IO	DDRSS Data	N2
DDR2_DQ9	IO	DDRSS Data	N4

**表 6-7. DDRSS2 Signal Descriptions (continued)**

SIGNAL NAME [1] (2) (3)	PIN TYPE [2]	DESCRIPTION [3]	ALY PIN [4]
DDR2_DQ10	IO	DDRSS Data	P2
DDR2_DQ11	IO	DDRSS Data	P3
DDR2_DQ12	IO	DDRSS Data	M7
DDR2_DQ13	IO	DDRSS Data	N5
DDR2_DQ14	IO	DDRSS Data	M4
DDR2_DQ15	IO	DDRSS Data	M3
DDR2_DQ16	IO	DDRSS Data	F3
DDR2_DQ17	IO	DDRSS Data	G7
DDR2_DQ18	IO	DDRSS Data	H6
DDR2_DQ19	IO	DDRSS Data	H4
DDR2_DQ20	IO	DDRSS Data	G2
DDR2_DQ21	IO	DDRSS Data	H3
DDR2_DQ22	IO	DDRSS Data	G5
DDR2_DQ23	IO	DDRSS Data	F2
DDR2_DQ24	IO	DDRSS Data	E4
DDR2_DQ25	IO	DDRSS Data	D2
DDR2_DQ26	IO	DDRSS Data	F6
DDR2_DQ27	IO	DDRSS Data	F5
DDR2_DQ28	IO	DDRSS Data	E3
DDR2_DQ29	IO	DDRSS Data	E7
DDR2_DQ30	IO	DDRSS Data	E6
DDR2_DQ31	IO	DDRSS Data	D4
DDR2_QS0N	IO	DDRS Complimentary Data Strobe	R1
DDR2_QS0P	IO	DDRS Data Strobe	T1
DDR2_QS1N	IO	DDRS Complimentary Data Strobe	M1
DDR2_QS1P	IO	DDRS Data Strobe	N1
DDR2_QS2N	IO	DDRS Complimentary Data Strobe	G1
DDR2_QS2P	IO	DDRS Data Strobe	H1
DDR2_QS3N	IO	DDRS Complimentary Data Strobe	D1
DDR2_QS3P	IO	DDRS Data Strobe	E1

- (1) An external 240 Ω ±1% resistor must be connected between this pin and VSS. No external voltage should be applied to this pin.
- (2) DDRSS0, DDRSS1, DDRSS2, and DDRSS3 must always be used in incremental order. For instance, when using a single LPDDR component, it must be connected to the DDR0\_\* interface. When using two LPDDR components, they must be connected to DDR0\_\* and DDR1\_\* interfaces, and so forth.
- (3) DDRSS2, DDRSS3, and SERDES2 are not available on the 27mm package variant of this SoC. DDRSS2/DDRSS3/SERDES2 should be avoided if software compatibility is desired with systems that use the 27mm package.

**表 6-8. DDRSS3 Signal Descriptions**

SIGNAL NAME [1] (2) (3)	PIN TYPE [2]	DESCRIPTION [3]	ALY PIN [4]
DDR3_CKN	IO	DDRSS Differential Clock (negative)	B25
DDR3_CKP	IO	DDRSS Differential Clock (positive)	A24
DDR3_RESETn	IO	DDRSS Reset	C23
DDR3_RET	I	DDR Retention Enable	G27
DDR3_CA0	IO	DDRSS Command Address	D25
DDR3_CA1	IO	DDRSS Command Address	B23
DDR3_CA2	IO	DDRSS Command Address	D24
DDR3_CA3	IO	DDRSS Command Address	C24

**表 6-8. DDRSS3 Signal Descriptions (continued)**

SIGNAL NAME [1] <sup>(2)</sup> <sup>(3)</sup>	PIN TYPE [2]	DESCRIPTION [3]	ALY PIN [4]
DDR3_CA4	IO	DDRSS Command Address	E23
DDR3_CA5	IO	DDRSS Command Address	F23
DDR3_CAL0 <sup>(1)</sup>	A	DDRSS IO Pad Calibration Resistor	F18
DDR3_CKE0	IO	DDRSS Clock Enable	C25
DDR3_CKE1	IO	DDRSS Clock Enable	G24
DDR3_CSn0_0	IO	DDRSS Chip Select	G23
DDR3_CSn0_1	IO	DDRSS Chip Select	G25
DDR3_CSn1_0	IO	DDRSS Chip Select	F25
DDR3_CSn1_1	IO	DDRSS Chip Select	E24
DDR3_DM0	IO	DDRSS Data Mask	E18
DDR3_DM1	IO	DDRSS Data Mask	D21
DDR3_DM2	IO	DDRSS Data Mask	C28
DDR3_DM3	IO	DDRSS Data Mask	E30
DDR3_DQ0	IO	DDRSS Data	D18
DDR3_DQ1	IO	DDRSS Data	B18
DDR3_DQ2	IO	DDRSS Data	C19
DDR3_DQ3	IO	DDRSS Data	D19
DDR3_DQ4	IO	DDRSS Data	F20
DDR3_DQ5	IO	DDRSS Data	E20
DDR3_DQ6	IO	DDRSS Data	G19
DDR3_DQ7	IO	DDRSS Data	F19
DDR3_DQ8	IO	DDRSS Data	E21
DDR3_DQ9	IO	DDRSS Data	G21
DDR3_DQ10	IO	DDRSS Data	F22
DDR3_DQ11	IO	DDRSS Data	D22
DDR3_DQ12	IO	DDRSS Data	C22
DDR3_DQ13	IO	DDRSS Data	B21
DDR3_DQ14	IO	DDRSS Data	B20
DDR3_DQ15	IO	DDRSS Data	C20
DDR3_DQ16	IO	DDRSS Data	B28
DDR3_DQ17	IO	DDRSS Data	B27
DDR3_DQ18	IO	DDRSS Data	C26
DDR3_DQ19	IO	DDRSS Data	D26
DDR3_DQ20	IO	DDRSS Data	F26
DDR3_DQ21	IO	DDRSS Data	G26
DDR3_DQ22	IO	DDRSS Data	E27
DDR3_DQ23	IO	DDRSS Data	D27
DDR3_DQ24	IO	DDRSS Data	F29
DDR3_DQ25	IO	DDRSS Data	G29
DDR3_DQ26	IO	DDRSS Data	F28
DDR3_DQ27	IO	DDRSS Data	E28
DDR3_DQ28	IO	DDRSS Data	D29
DDR3_DQ29	IO	DDRSS Data	C29
DDR3_DQ30	IO	DDRSS Data	B30
DDR3_DQ31	IO	DDRSS Data	D30

**表 6-8. DDRSS3 Signal Descriptions (continued)**

SIGNAL NAME [1] <sup>(2)</sup> <sup>(3)</sup>	PIN TYPE [2]	DESCRIPTION [3]	ALY PIN [4]
DDR3_DQS0N	IO	DDRSS Complimentary Data Strobe	A19
DDR3_DQS0P	IO	DDRSS Data Strobe	A18
DDR3_DQS1N	IO	DDRSS Complimentary Data Strobe	A22
DDR3_DQS1P	IO	DDRSS Data Strobe	A21
DDR3_DQS2N	IO	DDRSS Complimentary Data Strobe	A27
DDR3_DQS2P	IO	DDRSS Data Strobe	A26
DDR3_DQS3N	IO	DDRSS Complimentary Data Strobe	A30
DDR3_DQS3P	IO	DDRSS Data Strobe	A29

- (1) An external 240 Ω ±1% resistor must be connected between this pin and VSS. No external voltage should be applied to this pin.
- (2) DDRSS0, DDRSS1, DDRSS2, and DDRSS3 must always be used in incremental order. For instance, when using a single LPDDR component, it must be connected to the DDR0\_\* interface. When using two LPDDR components, they must be connected to DDR0\_\* and DDR1\_\* interfaces, and so forth.
- (3) DDRSS2, DDRSS3, and SERDES2 are not available on the 27mm package variant of this SoC. DDRSS2/DDRSS3/SERDES2 should be avoided if software compatibility is desired with systems that use the 27mm package.

### 6.3.3 GPIO

#### 6.3.3.1 MAIN Domain

**表 6-9. GPIO0 Signal Descriptions**

SIGNAL NAME [1]	PIN TYPE [2]	DESCRIPTION [3]	ALY PIN [4]
GPIO0_0	IO	General Purpose Input/Output	AN35
GPIO0_1	IO	General Purpose Input/Output	AG36
GPIO0_2	IO	General Purpose Input/Output	AJ33
GPIO0_3	IO	General Purpose Input/Output	AF33
GPIO0_4	IO	General Purpose Input/Output	AH33
GPIO0_5	IO	General Purpose Input/Output	AG33
GPIO0_6	IO	General Purpose Input/Output	AK36
GPIO0_7	IO	General Purpose Input/Output	AG34
GPIO0_8	IO	General Purpose Input/Output	AJ35
GPIO0_9	IO	General Purpose Input/Output	AH34
GPIO0_10	IO	General Purpose Input/Output	AE33
GPIO0_11	IO	General Purpose Input/Output	AL32
GPIO0_12	IO	General Purpose Input/Output	AK37
GPIO0_13	IO	General Purpose Input/Output	AJ34
GPIO0_14	IO	General Purpose Input/Output	AK35
GPIO0_15	IO	General Purpose Input/Output	AK38
GPIO0_16	IO	General Purpose Input/Output	AF37
GPIO0_17	IO	General Purpose Input/Output	AG37
GPIO0_18	IO	General Purpose Input/Output	AK33
GPIO0_19	IO	General Purpose Input/Output	AC32
GPIO0_20	IO	General Purpose Input/Output	AC37
GPIO0_21	IO	General Purpose Input/Output	AD37
GPIO0_22	IO	General Purpose Input/Output	AE37
GPIO0_23	IO	General Purpose Input/Output	AC36
GPIO0_24	IO	General Purpose Input/Output	AE36
GPIO0_25	IO	General Purpose Input/Output	AF38
GPIO0_26	IO	General Purpose Input/Output	AE38

**表 6-9. GPIO0 Signal Descriptions (continued)**

SIGNAL NAME [1]	PIN TYPE [2]	DESCRIPTION [3]	ALY PIN [4]
GPIO0_27	IO	General Purpose Input/Output	AJ37
GPIO0_28	IO	General Purpose Input/Output	AH38
GPIO0_29	IO	General Purpose Input/Output	AC33
GPIO0_30	IO	General Purpose Input/Output	AH37
GPIO0_31	IO	General Purpose Input/Output	AJ38
GPIO0_32	IO	General Purpose Input/Output	AK34
GPIO0_33	IO	General Purpose Input/Output	AG38
GPIO0_34	IO	General Purpose Input/Output	AF36
GPIO0_35	IO	General Purpose Input/Output	AE35
GPIO0_36	IO	General Purpose Input/Output	AC35
GPIO0_37	IO	General Purpose Input/Output	AG35
GPIO0_38	IO	General Purpose Input/Output	AH36
GPIO0_39	IO	General Purpose Input/Output	AF35
GPIO0_40	IO	General Purpose Input/Output	AD34
GPIO0_41	IO	General Purpose Input/Output	AJ36
GPIO0_42	IO	General Purpose Input/Output	AF34
GPIO0_43	IO	General Purpose Input/Output	AE34
GPIO0_44	IO	General Purpose Input/Output	AL33
GPIO0_45	IO	General Purpose Input/Output	AL34
GPIO0_46	IO	General Purpose Input/Output	AC34
GPIO0_47	IO	General Purpose Input/Output	AD33
GPIO0_48	IO	General Purpose Input/Output	AD38
GPIO0_49	IO	General Purpose Input/Output	AD36
GPIO0_50	IO	General Purpose Input/Output	AJ32
GPIO0_51	IO	General Purpose Input/Output	AM37
GPIO0_52	IO	General Purpose Input/Output	AP38
GPIO0_53	IO	General Purpose Input/Output	AN38
GPIO0_54	IO	General Purpose Input/Output	AM35
GPIO0_55	IO	General Purpose Input/Output	AM36
GPIO0_56	IO	General Purpose Input/Output	AN36
GPIO0_57	IO	General Purpose Input/Output	AP37
GPIO0_58	IO	General Purpose Input/Output	AR38
GPIO0_59	IO	General Purpose Input/Output	AN37
GPIO0_60	IO	General Purpose Input/Output	AC38
GPIO0_61	IO	General Purpose Input/Output	AA32
GPIO0_62	IO	General Purpose Input/Output	AB34
GPIO0_63	IO	General Purpose Input/Output	AA33
GPIO0_64	IO	General Purpose Input/Output	AB38
GPIO0_65	IO	General Purpose Input/Output	AB36

**6.3.3.2 WKUP Domain**

**表 6-10. WKUP\_GPIO0 Signal Descriptions**

SIGNAL NAME [1]	PIN TYPE [2]	DESCRIPTION [3]	ALY PIN [4]
WKUP_GPIO0_0	IO	General Purpose Input/Output	H38
WKUP_GPIO0_1	IO	General Purpose Input/Output	J34

**表 6-10. WKUP\_GPIO0 Signal Descriptions (continued)**

SIGNAL NAME [1]	PIN TYPE [2]	DESCRIPTION [3]	ALY PIN [4]
WKUP_GPIO0_2	IO	General Purpose Input/Output	J35
WKUP_GPIO0_3	IO	General Purpose Input/Output	J36
WKUP_GPIO0_4	IO	General Purpose Input/Output	H35
WKUP_GPIO0_5	IO	General Purpose Input/Output	K36
WKUP_GPIO0_6	IO	General Purpose Input/Output	L37
WKUP_GPIO0_7	IO	General Purpose Input/Output	L36
WKUP_GPIO0_8	IO	General Purpose Input/Output	L35
WKUP_GPIO0_9	IO	General Purpose Input/Output	L34
WKUP_GPIO0_10	IO	General Purpose Input/Output	L33
WKUP_GPIO0_11	IO	General Purpose Input/Output	M38
WKUP_GPIO0_12	IO	General Purpose Input/Output	J37
WKUP_GPIO0_13	IO	General Purpose Input/Output	K38
WKUP_GPIO0_14	IO	General Purpose Input/Output	H37
WKUP_GPIO0_15	IO	General Purpose Input/Output	K37
WKUP_GPIO0_16	IO	General Purpose Input/Output	E32
WKUP_GPIO0_17	IO	General Purpose Input/Output	D32
WKUP_GPIO0_18	IO	General Purpose Input/Output	C34
WKUP_GPIO0_19	IO	General Purpose Input/Output	B33
WKUP_GPIO0_20	IO	General Purpose Input/Output	B32
WKUP_GPIO0_21	IO	General Purpose Input/Output	C33
WKUP_GPIO0_22	IO	General Purpose Input/Output	C35
WKUP_GPIO0_23	IO	General Purpose Input/Output	D33
WKUP_GPIO0_24	IO	General Purpose Input/Output	D34
WKUP_GPIO0_25	IO	General Purpose Input/Output	E34
WKUP_GPIO0_26	IO	General Purpose Input/Output	E33
WKUP_GPIO0_27	IO	General Purpose Input/Output	A32
WKUP_GPIO0_28	IO	General Purpose Input/Output	A33
WKUP_GPIO0_29	IO	General Purpose Input/Output	B34
WKUP_GPIO0_30	IO	General Purpose Input/Output	C32
WKUP_GPIO0_31	IO	General Purpose Input/Output	F32
WKUP_GPIO0_32	IO	General Purpose Input/Output	C31
WKUP_GPIO0_33	IO	General Purpose Input/Output	F31
WKUP_GPIO0_34	IO	General Purpose Input/Output	E35
WKUP_GPIO0_35	IO	General Purpose Input/Output	D31
WKUP_GPIO0_36	IO	General Purpose Input/Output	G31
WKUP_GPIO0_37	IO	General Purpose Input/Output	F33
WKUP_GPIO0_38	IO	General Purpose Input/Output	G32
WKUP_GPIO0_39	IO	General Purpose Input/Output	G33
WKUP_GPIO0_40	IO	General Purpose Input/Output	C38
WKUP_GPIO0_41	IO	General Purpose Input/Output	C37
WKUP_GPIO0_42	IO	General Purpose Input/Output	E38
WKUP_GPIO0_43	IO	General Purpose Input/Output	E37
WKUP_GPIO0_44	IO	General Purpose Input/Output	D38
WKUP_GPIO0_45	IO	General Purpose Input/Output	D37
WKUP_GPIO0_46	IO	General Purpose Input/Output	E36

ADVANCE INFORMATION



**表 6-10. WKUP\_GPIO0 Signal Descriptions (continued)**

SIGNAL NAME [1]	PIN TYPE [2]	DESCRIPTION [3]	ALY PIN [4]
WKUP_GPIO0_47	IO	General Purpose Input/Output	B37
WKUP_GPIO0_48	IO	General Purpose Input/Output	D36
WKUP_GPIO0_49	IO	General Purpose Input/Output	M33
WKUP_GPIO0_50	IO	General Purpose Input/Output	B36
WKUP_GPIO0_51	IO	General Purpose Input/Output	A35
WKUP_GPIO0_52	IO	General Purpose Input/Output	B35
WKUP_GPIO0_53	IO	General Purpose Input/Output	A36
WKUP_GPIO0_54	IO	General Purpose Input/Output	G38
WKUP_GPIO0_55	IO	General Purpose Input/Output	H36
WKUP_GPIO0_56	IO	General Purpose Input/Output	M37
WKUP_GPIO0_57	IO	General Purpose Input/Output	M36
WKUP_GPIO0_58	IO	General Purpose Input/Output	K35
WKUP_GPIO0_59	IO	General Purpose Input/Output	K34
WKUP_GPIO0_60	IO	General Purpose Input/Output	K33
WKUP_GPIO0_61	IO	General Purpose Input/Output	F38
WKUP_GPIO0_62	IO	General Purpose Input/Output	C36
WKUP_GPIO0_63	IO	General Purpose Input/Output	N33
WKUP_GPIO0_64	IO	General Purpose Input/Output	N35
WKUP_GPIO0_65	IO	General Purpose Input/Output	M35
WKUP_GPIO0_66	IO	General Purpose Input/Output	N34
WKUP_GPIO0_67	IO	General Purpose Input/Output	M34
WKUP_GPIO0_68	IO	General Purpose Input/Output	F36
WKUP_GPIO0_69	IO	General Purpose Input/Output	J38
WKUP_GPIO0_70	IO	General Purpose Input/Output	F37
WKUP_GPIO0_71	I	General Purpose Input/Output	P36
WKUP_GPIO0_72	I	General Purpose Input/Output	V36
WKUP_GPIO0_73	I	General Purpose Input/Output	T34
WKUP_GPIO0_74	I	General Purpose Input/Output	T36
WKUP_GPIO0_75	I	General Purpose Input/Output	P34
WKUP_GPIO0_76	I	General Purpose Input/Output	R37
WKUP_GPIO0_77	I	General Purpose Input/Output	R33
WKUP_GPIO0_78	I	General Purpose Input/Output	V38
WKUP_GPIO0_79	I	General Purpose Input/Output	Y38
WKUP_GPIO0_80	I	General Purpose Input/Output	Y34
WKUP_GPIO0_81	I	General Purpose Input/Output	V34
WKUP_GPIO0_82	I	General Purpose Input/Output	W37
WKUP_GPIO0_83	I	General Purpose Input/Output	AA37
WKUP_GPIO0_84	I	General Purpose Input/Output	W33
WKUP_GPIO0_85	I	General Purpose Input/Output	U33
WKUP_GPIO0_86	I	General Purpose Input/Output	Y36
WKUP_GPIO0_87	IO	General Purpose Input/Output	G34
WKUP_GPIO0_88	IO	General Purpose Input/Output	L38

### 6.3.4 I2C

#### 6.3.4.1 MAIN Domain

**表 6-11. I2C0 Signal Descriptions**

SIGNAL NAME [1]	PIN TYPE [2]	DESCRIPTION [3]	ALY PIN [4]
I2C0_SCL	IOD	I2C Clock	AN36
I2C0_SDA	IOD	I2C Data	AP37

**表 6-12. I2C1 Signal Descriptions**

SIGNAL NAME [1]	PIN TYPE [2]	DESCRIPTION [3]	ALY PIN [4]
I2C1_SCL	IOD	I2C Clock	AD36, AE34, AJ35
I2C1_SDA	IOD	I2C Data	AH34, AJ32, AL33

**表 6-13. I2C2 Signal Descriptions**

SIGNAL NAME [1]	PIN TYPE [2]	DESCRIPTION [3]	ALY PIN [4]
I2C2_SCL	IOD	I2C Clock	AC32, AN38
I2C2_SDA	IOD	I2C Data	AC37, AM35

**表 6-14. I2C3 Signal Descriptions**

SIGNAL NAME [1]	PIN TYPE [2]	DESCRIPTION [3]	ALY PIN [4]
I2C3_SCL	IOD	I2C Clock	AC38, AF38
I2C3_SDA	IOD	I2C Data	AA32, AE36

**表 6-15. I2C4 Signal Descriptions**

SIGNAL NAME [1]	PIN TYPE [2]	DESCRIPTION [3]	ALY PIN [4]
I2C4_SCL	IOD	I2C Clock	AA33, AG33, AG38
I2C4_SDA	IOD	I2C Data	AB34, AH33, AK34

**表 6-16. I2C5 Signal Descriptions**

SIGNAL NAME [1]	PIN TYPE [2]	DESCRIPTION [3]	ALY PIN [4]
I2C5_SCL	IOD	I2C Clock	AC33, AG34
I2C5_SDA	IOD	I2C Data	AH37, AK36

**表 6-17. I2C6 Signal Descriptions**

SIGNAL NAME [1]	PIN TYPE [2]	DESCRIPTION [3]	ALY PIN [4]
I2C6_SCL	IOD	I2C Clock	AB36, AN37
I2C6_SDA	IOD	I2C Data	AB38, AR38

#### 6.3.4.2 MCU Domain

**表 6-18. MCU\_I2C0 Signal Descriptions**

SIGNAL NAME [1]	PIN TYPE [2]	DESCRIPTION [3]	ALY PIN [4]
MCU_I2C0_SCL	IOD	I2C Clock	M35
MCU_I2C0_SDA	IOD	I2C Data	G34

**表 6-19. MCU\_I2C1 Signal Descriptions**

SIGNAL NAME [1]	PIN TYPE [2]	DESCRIPTION [3]	ALY PIN [4]
MCU_I2C1_SCL	IOD	I2C Clock	L35, L37

**表 6-19. MCU\_I2C1 Signal Descriptions (continued)**

SIGNAL NAME [1]	PIN TYPE [2]	DESCRIPTION [3]	ALY PIN [4]
MCU_I2C1_SDA	IOD	I2C Data	L34, L36

### 6.3.4.3 WKUP Domain

**表 6-20. WKUP\_I2C0 Signal Descriptions**

SIGNAL NAME [1]	PIN TYPE [2]	DESCRIPTION [3]	ALY PIN [4]
WKUP_I2C0_SCL	IOD	I2C Clock	N33
WKUP_I2C0_SDA	IOD	I2C Data	N35

### 6.3.5 I3C

#### 6.3.5.1 MCU Domain

**表 6-21. MCU\_I3C0 Signal Descriptions**

SIGNAL NAME [1]	PIN TYPE [2]	DESCRIPTION [3]	ALY PIN [4]
MCU_I3C0_SCL	IO	I3C Clock	L35
MCU_I3C0_SDA	IO	I3C Data	L34
MCU_I3C0_SDAPULLEN	OD	I3C Data Pull Enable	L38, M38

### 6.3.6 MCAN

#### 6.3.6.1 MAIN Domain

**表 6-22. MCAN0 Signal Descriptions**

SIGNAL NAME [1]	PIN TYPE [2]	DESCRIPTION [3]	ALY PIN [4]
MCAN0_RX	I	MCAN Receive Data	AE38
MCAN0_TX	O	MCAN Transmit Data	AF38

**表 6-23. MCAN1 Signal Descriptions**

SIGNAL NAME [1]	PIN TYPE [2]	DESCRIPTION [3]	ALY PIN [4]
MCAN1_RX	I	MCAN Receive Data	AH38, AJ32
MCAN1_TX	O	MCAN Transmit Data	AJ37

**表 6-24. MCAN2 Signal Descriptions**

SIGNAL NAME [1]	PIN TYPE [2]	DESCRIPTION [3]	ALY PIN [4]
MCAN2_RX	I	MCAN Receive Data	AH37
MCAN2_TX	O	MCAN Transmit Data	AC33

**表 6-25. MCAN3 Signal Descriptions**

SIGNAL NAME [1]	PIN TYPE [2]	DESCRIPTION [3]	ALY PIN [4]
MCAN3_RX	I	MCAN Receive Data	AK34
MCAN3_TX	O	MCAN Transmit Data	AJ38

**表 6-26. MCAN4 Signal Descriptions**

SIGNAL NAME [1]	PIN TYPE [2]	DESCRIPTION [3]	ALY PIN [4]
MCAN4_RX	I	MCAN Receive Data	AF36
MCAN4_TX	O	MCAN Transmit Data	AG38

**表 6-27. MCAN5 Signal Descriptions**

SIGNAL NAME [1]	PIN TYPE [2]	DESCRIPTION [3]	ALY PIN [4]
MCAN5_RX	I	MCAN Receive Data	AC35, AK38
MCAN5_TX	O	MCAN Transmit Data	AE35, AK35

**表 6-28. MCAN6 Signal Descriptions**

SIGNAL NAME [1]	PIN TYPE [2]	DESCRIPTION [3]	ALY PIN [4]
MCAN6_RX	I	MCAN Receive Data	AG37, AH36
MCAN6_TX	O	MCAN Transmit Data	AF37, AG35

**表 6-29. MCAN7 Signal Descriptions**

SIGNAL NAME [1]	PIN TYPE [2]	DESCRIPTION [3]	ALY PIN [4]
MCAN7_RX	I	MCAN Receive Data	AC32, AD34
MCAN7_TX	O	MCAN Transmit Data	AF35, AK33

**表 6-30. MCAN8 Signal Descriptions**

SIGNAL NAME [1]	PIN TYPE [2]	DESCRIPTION [3]	ALY PIN [4]
MCAN8_RX	I	MCAN Receive Data	AD37, AF34
MCAN8_TX	O	MCAN Transmit Data	AC37, AJ36

**表 6-31. MCAN9 Signal Descriptions**

SIGNAL NAME [1]	PIN TYPE [2]	DESCRIPTION [3]	ALY PIN [4]
MCAN9_RX	I	MCAN Receive Data	AC36, AL33
MCAN9_TX	O	MCAN Transmit Data	AE34, AE37

**表 6-32. MCAN10 Signal Descriptions**

SIGNAL NAME [1]	PIN TYPE [2]	DESCRIPTION [3]	ALY PIN [4]
MCAN10_RX	I	MCAN Receive Data	AC34
MCAN10_TX	O	MCAN Transmit Data	AL34

**表 6-33. MCAN11 Signal Descriptions**

SIGNAL NAME [1]	PIN TYPE [2]	DESCRIPTION [3]	ALY PIN [4]
MCAN11_RX	I	MCAN Receive Data	AD38
MCAN11_TX	O	MCAN Transmit Data	AD33

**表 6-34. MCAN12 Signal Descriptions**

SIGNAL NAME [1]	PIN TYPE [2]	DESCRIPTION [3]	ALY PIN [4]
MCAN12_RX	I	MCAN Receive Data	AJ33, AK37
MCAN12_TX	O	MCAN Transmit Data	AD36, AG36

**表 6-35. MCAN13 Signal Descriptions**

SIGNAL NAME [1]	PIN TYPE [2]	DESCRIPTION [3]	ALY PIN [4]
MCAN13_RX	I	MCAN Receive Data	AH33, AN37
MCAN13_TX	O	MCAN Transmit Data	AF33, AR38

**表 6-36. MCAN14 Signal Descriptions**

SIGNAL NAME [1]	PIN TYPE [2]	DESCRIPTION [3]	ALY PIN [4]
MCAN14_RX	I	MCAN Receive Data	AK36, AP38
MCAN14_TX	O	MCAN Transmit Data	AG33, AM37

**表 6-37. MCAN15 Signal Descriptions**

SIGNAL NAME [1]	PIN TYPE [2]	DESCRIPTION [3]	ALY PIN [4]
MCAN15_RX	I	MCAN Receive Data	AB36, AJ35
MCAN15_TX	O	MCAN Transmit Data	AB38, AG34

**表 6-38. MCAN16 Signal Descriptions**

SIGNAL NAME [1]	PIN TYPE [2]	DESCRIPTION [3]	ALY PIN [4]
MCAN16_RX	I	MCAN Receive Data	AE33
MCAN16_TX	O	MCAN Transmit Data	AH34

**表 6-39. MCAN17 Signal Descriptions**

SIGNAL NAME [1]	PIN TYPE [2]	DESCRIPTION [3]	ALY PIN [4]
MCAN17_RX	I	MCAN Receive Data	AE36, AJ34
MCAN17_TX	O	MCAN Transmit Data	AL32

### 6.3.6.2 MCU Domain

**表 6-40. MCU\_MCAN0 Signal Descriptions**

SIGNAL NAME [1]	PIN TYPE [2]	DESCRIPTION [3]	ALY PIN [4]
MCU_MCAN0_RX	I	MCAN Receive Data	F38
MCU_MCAN0_TX	O	MCAN Transmit Data	K33

**表 6-41. MCU\_MCAN1 Signal Descriptions**

SIGNAL NAME [1]	PIN TYPE [2]	DESCRIPTION [3]	ALY PIN [4]
MCU_MCAN1_RX	I	MCAN Receive Data	K36
MCU_MCAN1_TX	O	MCAN Transmit Data	H35

### 6.3.7 MCSPI

#### 6.3.7.1 MAIN Domain

**表 6-42. MCSPI0 Signal Descriptions**

SIGNAL NAME [1]	PIN TYPE [2]	DESCRIPTION [3]	ALY PIN [4]
SPI0_CLK	IO	SPI Clock	AN38
SPI0_CS0	IO	SPI Chip Select 0	AM37
SPI0_CS1	IO	SPI Chip Select 1	AP38
SPI0_CS2	IO	SPI Chip Select 2	AJ35
SPI0_CS3	IO	SPI Chip Select 3	AE33
SPI0_D0	IO	SPI Data 0	AM35
SPI0_D1	IO	SPI Data 1	AM36

**表 6-43. MCSPI1 Signal Descriptions**

SIGNAL NAME [1]	PIN TYPE [2]	DESCRIPTION [3]	ALY PIN [4]
SPI1_CLK	IO	SPI Clock	AB38

**表 6-43. MCSPI1 Signal Descriptions (continued)**

SIGNAL NAME [1]	PIN TYPE [2]	DESCRIPTION [3]	ALY PIN [4]
SPI1_CS0	IO	SPI Chip Select 0	AC38
SPI1_CS1	IO	SPI Chip Select 1	AA32
SPI1_CS2	IO	SPI Chip Select 2	AB34
SPI1_CS3	IO	SPI Chip Select 3	AH34
SPI1_D0	IO	SPI Data 0	AA33
SPI1_D1	IO	SPI Data 1	AB36

**表 6-44. MCSPI2 Signal Descriptions**

SIGNAL NAME [1]	PIN TYPE [2]	DESCRIPTION [3]	ALY PIN [4]
SPI2_CLK	IO	SPI Clock	AD34
SPI2_CS0	IO	SPI Chip Select 0	AJ36
SPI2_CS1	IO	SPI Chip Select 1	AF35
SPI2_CS2	IO	SPI Chip Select 2	AF37
SPI2_CS3	IO	SPI Chip Select 3	AG37
SPI2_D0	IO	SPI Data 0	AF34
SPI2_D1	IO	SPI Data 1	AE34

**表 6-45. MCSPI3 Signal Descriptions**

SIGNAL NAME [1]	PIN TYPE [2]	DESCRIPTION [3]	ALY PIN [4]
SPI3_CLK	IO	SPI Clock	AD38
SPI3_CS0	IO	SPI Chip Select 0	AD33
SPI3_CS1	IO	SPI Chip Select 1	AJ38
SPI3_CS2	IO	SPI Chip Select 2	AF36
SPI3_CS3	IO	SPI Chip Select 3	AC34
SPI3_D0	IO	SPI Data 0	AC32
SPI3_D1	IO	SPI Data 1	AC37

**表 6-46. MCSPI5 Signal Descriptions**

SIGNAL NAME [1]	PIN TYPE [2]	DESCRIPTION [3]	ALY PIN [4]
SPI5_CLK	IO	SPI Clock	AJ38
SPI5_CS0	IO	SPI Chip Select 0	AE38
SPI5_CS1	IO	SPI Chip Select 1	AF38
SPI5_CS2	IO	SPI Chip Select 2	AD37
SPI5_CS3	IO	SPI Chip Select 3	AE37
SPI5_D0	IO	SPI Data 0	AH38
SPI5_D1	IO	SPI Data 1	AF36

**表 6-47. MCSPI6 Signal Descriptions**

SIGNAL NAME [1]	PIN TYPE [2]	DESCRIPTION [3]	ALY PIN [4]
SPI6_CLK	IO	SPI Clock	AK37
SPI6_CS0	IO	SPI Chip Select 0	AJ34
SPI6_CS1	IO	SPI Chip Select 1	AH37
SPI6_CS2	IO	SPI Chip Select 2	AK34
SPI6_CS3	IO	SPI Chip Select 3	AG38
SPI6_D0	IO	SPI Data 0	AD36

**表 6-47. MCSPI6 Signal Descriptions (continued)**

SIGNAL NAME [1]	PIN TYPE [2]	DESCRIPTION [3]	ALY PIN [4]
SPI6_D1	IO	SPI Data 1	AC33

**表 6-48. MCSPI7 Signal Descriptions**

SIGNAL NAME [1]	PIN TYPE [2]	DESCRIPTION [3]	ALY PIN [4]
SPI7_CLK	IO	SPI Clock	AF37
SPI7_CS0	IO	SPI Chip Select 0	AG37
SPI7_CS1	IO	SPI Chip Select 1	AD37
SPI7_CS2	IO	SPI Chip Select 2	AE37
SPI7_CS3	IO	SPI Chip Select 3	AL32
SPI7_D0	IO	SPI Data 0	AE38
SPI7_D1	IO	SPI Data 1	AJ38

### 6.3.7.2 MCU Domain

**表 6-49. MCU\_MCSPI0 Signal Descriptions**

SIGNAL NAME [1]	PIN TYPE [2]	DESCRIPTION [3]	ALY PIN [4]
MCU_SPI0_CLK	IO	SPI Clock	G38
MCU_SPI0_CS0	IO	SPI Chip Select 0	F37
MCU_SPI0_CS1	IO	SPI Chip Select 1	F33, J37
MCU_SPI0_CS2	IO	SPI Chip Select 2	G33, H37
MCU_SPI0_CS3	IO	SPI Chip Select 3	H35
MCU_SPI0_D0	IO	SPI Data 0	H36
MCU_SPI0_D1	IO	SPI Data 1	J38

**表 6-50. MCU\_MCSPI1 Signal Descriptions**

SIGNAL NAME [1]	PIN TYPE [2]	DESCRIPTION [3]	ALY PIN [4]
MCU_SPI1_CLK	IO	SPI Clock	H38
MCU_SPI1_CS0	IO	SPI Chip Select 0	J36
MCU_SPI1_CS1	IO	SPI Chip Select 1	D31, K38
MCU_SPI1_CS2	IO	SPI Chip Select 2	G31, K37
MCU_SPI1_CS3	IO	SPI Chip Select 3	K36
MCU_SPI1_D0	IO	SPI Data 0	J34
MCU_SPI1_D1	IO	SPI Data 1	J35

### 6.3.8 UART

#### 6.3.8.1 MAIN Domain

**表 6-51. UART0 Signal Descriptions**

SIGNAL NAME [1]	PIN TYPE [2]	DESCRIPTION [3]	ALY PIN [4]
UART0_CTSn	I	UART Clear to Send (active low)	AC32, AC38
UART0_DCDn	I	UART Data Carrier Detect (active low)	AJ33
UART0_DSRn	I	UART Data Set Ready (active low)	AF33
UART0_DTRn	O	UART Data Terminal Ready (active low)	AH33
UART0_RIn	I	UART Ring Indicator	AG33
UART0_RTSn	O	UART Request to Send (active low)	AB38, AC37, AP38
UART0_RXD	I	UART Receive Data	AD33

**表 6-51. UART0 Signal Descriptions (continued)**

SIGNAL NAME [1]	PIN TYPE [2]	DESCRIPTION [3]	ALY PIN [4]
UART0_TXD	O	UART Transmit Data	AD38

**表 6-52. UART1 Signal Descriptions**

SIGNAL NAME [1]	PIN TYPE [2]	DESCRIPTION [3]	ALY PIN [4]
UART1_CTSn	I	UART Clear to Send (active low)	AC36, AN38
UART1_RTSn	O	UART Request to Send (active low)	AE36, AM35
UART1_RXD	I	UART Receive Data	AD37
UART1_TXD	O	UART Transmit Data	AE37

**表 6-53. UART2 Signal Descriptions**

SIGNAL NAME [1]	PIN TYPE [2]	DESCRIPTION [3]	ALY PIN [4]
UART2_CTSn	I	UART Clear to Send (active low)	AD36
UART2_RTSn	O	UART Request to Send (active low)	AJ32
UART2_RXD	I	UART Receive Data	AB34, AF38, AM35
UART2_TXD	O	UART Transmit Data	AA33, AE38, AM36

**表 6-54. UART3 Signal Descriptions**

SIGNAL NAME [1]	PIN TYPE [2]	DESCRIPTION [3]	ALY PIN [4]
UART3_CTSn	I	UART Clear to Send (active low)	AJ38
UART3_RTSn	O	UART Request to Send (active low)	AH38
UART3_RXD	I	UART Receive Data	AC33, AD36, AR38
UART3_TXD	O	UART Transmit Data	AH37, AJ32, AN37

**表 6-55. UART4 Signal Descriptions**

SIGNAL NAME [1]	PIN TYPE [2]	DESCRIPTION [3]	ALY PIN [4]
UART4_CTSn	I	UART Clear to Send (active low)	AB38, AG35, AK33
UART4_RTSn	O	UART Request to Send (active low)	AB36, AC34, AH36
UART4_RXD	I	UART Receive Data	AB34, AE35, AF37, AL34
UART4_TXD	O	UART Transmit Data	AA33, AC35, AF33, AG37

**表 6-56. UART5 Signal Descriptions**

SIGNAL NAME [1]	PIN TYPE [2]	DESCRIPTION [3]	ALY PIN [4]
UART5_CTSn	I	UART Clear to Send (active low)	AB34, AJ36
UART5_RTSn	O	UART Request to Send (active low)	AA33, AF34
UART5_RXD	I	UART Receive Data	AC38, AF35, AJ33
UART5_TXD	O	UART Transmit Data	AA32, AD34, AG36

**表 6-57. UART6 Signal Descriptions**

SIGNAL NAME [1]	PIN TYPE [2]	DESCRIPTION [3]	ALY PIN [4]
UART6_CTSn	I	UART Clear to Send (active low)	AF38
UART6_RTSn	O	UART Request to Send (active low)	AE38
UART6_RXD	I	UART Receive Data	AC36, AG33, AK37
UART6_TXD	O	UART Transmit Data	AE36, AH33, AJ37



**表 6-58. UART7 Signal Descriptions**

SIGNAL NAME [1]	PIN TYPE [2]	DESCRIPTION [3]	ALY PIN [4]
UART7_CTSn	I	UART Clear to Send (active low)	AB34
UART7_RTSn	O	UART Request to Send (active low)	AA33
UART7_RXD	I	UART Receive Data	AC38, AJ36, AL32
UART7_TXD	O	UART Transmit Data	AA32, AF34, AJ34

**表 6-59. UART8 Signal Descriptions**

SIGNAL NAME [1]	PIN TYPE [2]	DESCRIPTION [3]	ALY PIN [4]
UART8_CTSn	I	UART Clear to Send (active low)	AF37
UART8_RTSn	O	UART Request to Send (active low)	AG37
UART8_RXD	I	UART Receive Data	AB38, AE34, AK35, AP38
UART8_TXD	O	UART Transmit Data	AB36, AK38, AL33, AN38

**表 6-60. UART9 Signal Descriptions**

SIGNAL NAME [1]	PIN TYPE [2]	DESCRIPTION [3]	ALY PIN [4]
UART9_CTSn	I	UART Clear to Send (active low)	AK33, AK37
UART9_RTSn	O	UART Request to Send (active low)	AC34, AJ34
UART9_RXD	I	UART Receive Data	AC32, AG34
UART9_TXD	O	UART Transmit Data	AC37, AK36

### 6.3.8.2 MCU Domain

**表 6-61. MCU\_UART0 Signal Descriptions**

SIGNAL NAME [1]	PIN TYPE [2]	DESCRIPTION [3]	ALY PIN [4]
MCU_UART0_CTSn	I	UART Clear to Send (active low)	F33, H37
MCU_UART0_RTSn	O	UART Request to Send (active low)	G33, K37
MCU_UART0_RXD	I	UART Receive Data	D31, K38, M38
MCU_UART0_TXD	O	UART Transmit Data	G31, J37, L33

### 6.3.8.3 WKUP Domain

**表 6-62. WKUP\_UART0 Signal Descriptions**

SIGNAL NAME [1]	PIN TYPE [2]	DESCRIPTION [3]	ALY PIN [4]
WKUP_UART0_CTSn	I	UART Clear to Send (active low)	L37
WKUP_UART0_RTSn	O	UART Request to Send (active low)	L36
WKUP_UART0_RXD	I	UART Receive Data	K35
WKUP_UART0_TXD	O	UART Transmit Data	K34

### 6.3.9 MDIO

#### 6.3.9.1 MAIN Domain

**表 6-63. MDIO0 Signal Descriptions**

SIGNAL NAME [1]	PIN TYPE [2]	DESCRIPTION [3]	ALY PIN [4]
MDIO0_MDC	O	MDIO Clock	AD38
MDIO0_MDIO	IO	MDIO Data	AD33

**表 6-64. MDIO1 Signal Descriptions**

SIGNAL NAME [1]	PIN TYPE [2]	DESCRIPTION [3]	ALY PIN [4]
MDIO1_MDC	O	MDIO Clock	AE37
MDIO1_MDIO	IO	MDIO Data	AC36

### 6.3.9.2 MCU Domain

**表 6-65. MCU\_MDIO0 Signal Descriptions**

SIGNAL NAME [1]	PIN TYPE [2]	DESCRIPTION [3]	ALY PIN [4]
MCU_MDIO0_MDC	O	MDIO Clock	A36
MCU_MDIO0_MDIO	IO	MDIO Data	B35

### 6.3.10 UFS

#### 6.3.10.1 MAIN Domain

**表 6-66. UFS0 Signal Descriptions**

SIGNAL NAME [1]	PIN TYPE [2]	DESCRIPTION [3]	ALY PIN [4]
UFS0_REF_CLK	I	UFS Reference Clock	AM7
UFS0_RSTn	I	UFS Reset	AM8
UFS0_RX_DN0	I	UFS Receive Data (negative)	AM4
UFS0_RX_DN1	I	UFS Receive Data (negative)	AM1
UFS0_RX_DP0	I	UFS Receive Data (positive)	AM5
UFS0_RX_DP1	I	UFS Receive Data (positive)	AM2
UFS0_TX_DN0	I	UFS Transmit Data (negative)	AL2
UFS0_TX_DN1	I	UFS Transmit Data (negative)	AN2
UFS0_TX_DP0	I	UFS Transmit Data (positive)	AL3
UFS0_TX_DP1	I	UFS Transmit Data (positive)	AN3

### 6.3.11 CPSW2G

#### 6.3.11.1 MAIN Domain

**表 6-67. CPSW2G0 Signal Descriptions**

SIGNAL NAME [1]	PIN TYPE [2]	DESCRIPTION [3]	ALY PIN [4]
CLKOUT	IO	RMII Clock Output	AF34
RGMII1_RXC	I	RGMII Receive Clock	AL33
RGMII1_RX_CTL	I	RGMII Receive Control	AE34
RGMII1_TXC	O	RGMII Transmit Clock	AL34
RGMII1_TX_CTL	O	RGMII Transmit Control	AF35
RGMII1_RD0	I	RGMII Receive Data 0	AC34
RGMII1_RD1	I	RGMII Receive Data 1	AD34
RGMII1_RD2	I	RGMII Receive Data 2	AJ36
RGMII1_RD3	I	RGMII Receive Data 3	AF34
RGMII1_TD0	O	RGMII Transmit Data 0	AE35
RGMII1_TD1	O	RGMII Transmit Data 1	AC35
RGMII1_TD2	O	RGMII Transmit Data 2	AG35
RGMII1_TD3	O	RGMII Transmit Data 3	AH36
RMII1_CRSDV	I	RMII Carrier Sense / Data Valid	AH36
RMII1_RX_ER	I	RMII Receive Data Error	AF35
RMII1_TX_EN	O	RMII Transmit Enable	AE34

**表 6-67. CPSW2G0 Signal Descriptions (continued)**

SIGNAL NAME [1]	PIN TYPE [2]	DESCRIPTION [3]	ALY PIN [4]
RMII1_RXD0	I	RMII Receive Data 0	AC35
RMII1_RXD1	I	RMII Receive Data 1	AG35
RMII1_TXD0	O	RMII Transmit Data 0	AD34
RMII1_TXD1	O	RMII Transmit Data 1	AL33
RMII_REF_CLK	I	RMII Reference Clock	AJ36

### 6.3.11.2 MCU Domain

**表 6-68. MCU\_CPSW2G0 Signal Descriptions**

SIGNAL NAME [1]	PIN TYPE [2]	DESCRIPTION [3]	ALY PIN [4]
MCU_RGMII1_RXC	I	RGMII Receive Clock	B37
MCU_RGMII1_RX_CTL	I	RGMII Receive Control	C37
MCU_RGMII1_TXC	O	RGMII Transmit Clock	E36
MCU_RGMII1_TX_CTL	O	RGMII Transmit Control	C38
MCU_RGMII1_RD0	I	RGMII Receive Data 0	A35
MCU_RGMII1_RD1	I	RGMII Receive Data 1	B36
MCU_RGMII1_RD2	I	RGMII Receive Data 2	C36
MCU_RGMII1_RD3	I	RGMII Receive Data 3	D36
MCU_RGMII1_TD0	O	RGMII Transmit Data 0	D37
MCU_RGMII1_TD1	O	RGMII Transmit Data 1	D38
MCU_RGMII1_TD2	O	RGMII Transmit Data 2	E37
MCU_RGMII1_TD3	O	RGMII Transmit Data 3	E38
MCU_RMII1_CRD_DV	I	RMII Carrier Sense / Data Valid	C38
MCU_RMII1_REF_CLK	I	RMII Reference Clock	B37
MCU_RMII1_RX_ER	I	RMII Receive Data Error	C37
MCU_RMII1_TX_EN	O	RMII Transmit Enable	E36
MCU_RMII1_RXD0	I	RMII Receive Data 0	A35
MCU_RMII1_RXD1	I	RMII Receive Data 1	B36
MCU_RMII1_TXD0	O	RMII Transmit Data 0	D37
MCU_RMII1_TXD1	O	RMII Transmit Data 1	D38

### 6.3.12 SGMII

#### 6.3.12.1 MAIN Domain

**表 6-69. CPSW9X0 Signal Descriptions**

SIGNAL NAME [1]	PIN TYPE [2]	DESCRIPTION [3]	ALY PIN [4]
SGMII1_RXN0	I	SGMII Receive (negative)	AU2, AU20
SGMII1_RXP0	I	SGMII Receive (positive)	AU21, AU3
SGMII1_TXN0	O	SGMII Transmit (negative)	AR2, AR20
SGMII1_TXP0	O	SGMII Transmit (positive)	AR21, AR3
SGMII2_RXN0	I	SGMII Receive (negative)	AT1, AT19
SGMII2_RXP0	I	SGMII Receive (positive)	AT2, AT20
SGMII2_TXN0	O	SGMII Transmit (negative)	AP1, AP19
SGMII2_TXP0	O	SGMII Transmit (positive)	AP2, AP20
SGMII3_RXN0	I	SGMII Receive (negative)	AU5
SGMII3_RXP0	I	SGMII Receive (positive)	AU6
SGMII3_TXN0	O	SGMII Transmit (negative)	AV6

**表 6-69. CPSW9X0 Signal Descriptions (continued)**

SIGNAL NAME [1]	PIN TYPE [2]	DESCRIPTION [3]	ALY PIN [4]
SGMII3_TXP0	O	SGMII Transmit (positive)	AV7
SGMII4_RXN0	I	SGMII Receive (negative)	AT4
SGMII4_RXP0	I	SGMII Receive (positive)	AT5
SGMII4_TXN0	O	SGMII Transmit (negative)	AR5
SGMII4_TXP0	O	SGMII Transmit (positive)	AR6
SGMII5_RXN0	I	SGMII Receive (negative)	AR14, AU23
SGMII5_RXP0	I	SGMII Receive (positive)	AR15, AU24
SGMII5_TXN0	O	SGMII Transmit (negative)	AP13, AV24
SGMII5_TXP0	O	SGMII Transmit (positive)	AP14, AV25
SGMII6_RXN0	I	SGMII Receive (negative)	AT22, AU14
SGMII6_RXP0	I	SGMII Receive (positive)	AT23, AU15
SGMII6_TXN0	O	SGMII Transmit (negative)	AR23, AT13
SGMII6_TXP0	O	SGMII Transmit (positive)	AR24, AT14
SGMII7_RXN0	I	SGMII Receive (negative)	AR17, AU20
SGMII7_RXP0	I	SGMII Receive (positive)	AR18, AU21
SGMII7_TXN0	O	SGMII Transmit (negative)	AR20, AT16
SGMII7_TXP0	O	SGMII Transmit (positive)	AR21, AT17
SGMII8_RXN0	I	SGMII Receive (negative)	AT19, AU17
SGMII8_RXP0	I	SGMII Receive (positive)	AT20, AU18
SGMII8_TXN0	O	SGMII Transmit (negative)	AP19, AV18
SGMII8_TXP0	O	SGMII Transmit (positive)	AP20, AV19

### 6.3.13 ECAP

#### 6.3.13.1 MAIN Domain

**表 6-70. ECAP0 Signal Descriptions**

SIGNAL NAME [1]	PIN TYPE [2]	DESCRIPTION [3]	ALY PIN [4]
ECAP0_IN_APWM_OUT	IO	Enhanced Capture (ECAP) Input or Auxiliary PWM (APWM) Output	AB34, AD36

**表 6-71. ECAP1 Signal Descriptions**

SIGNAL NAME [1]	PIN TYPE [2]	DESCRIPTION [3]	ALY PIN [4]
ECAP1_IN_APWM_OUT	IO	Enhanced Capture (ECAP) Input or Auxiliary PWM (APWM) Output	AA33, AR38

**表 6-72. ECAP2 Signal Descriptions**

SIGNAL NAME [1]	PIN TYPE [2]	DESCRIPTION [3]	ALY PIN [4]
ECAP2_IN_APWM_OUT	IO	Enhanced Capture (ECAP) Input or Auxiliary PWM (APWM) Output	AN37

### 6.3.14 EQEP

#### 6.3.14.1 MAIN Domain

**表 6-73. EQEP0 Signal Descriptions**

SIGNAL NAME [1]	PIN TYPE [2]	DESCRIPTION [3]	ALY PIN [4]
EQEP0_A	I	EQEP Quadrature Input A	AF34
EQEP0_B	I	EQEP Quadrature Input B	AE34

**表 6-73. EQEP0 Signal Descriptions (continued)**

SIGNAL NAME [1]	PIN TYPE [2]	DESCRIPTION [3]	ALY PIN [4]
EQEP0_I	IO	EQEP Index	AD33
EQEP0_S	IO	EQEP Strobe	AC34

**表 6-74. EQEP1 Signal Descriptions**

SIGNAL NAME [1]	PIN TYPE [2]	DESCRIPTION [3]	ALY PIN [4]
EQEP1_A	I	EQEP Quadrature Input A	AL33
EQEP1_B	I	EQEP Quadrature Input B	AL34
EQEP1_I	IO	EQEP Index	AK37
EQEP1_S	IO	EQEP Strobe	AD38

**表 6-75. EQEP2 Signal Descriptions**

SIGNAL NAME [1]	PIN TYPE [2]	DESCRIPTION [3]	ALY PIN [4]
EQEP2_A	I	EQEP Quadrature Input A	AK33
EQEP2_B	I	EQEP Quadrature Input B	AC37
EQEP2_I	IO	EQEP Index	AC36
EQEP2_S	IO	EQEP Strobe	AD37

### 6.3.15 EPWM

#### 6.3.15.1 MAIN Domain

**表 6-76. EPWM Signal Descriptions**

SIGNAL NAME [1]	PIN TYPE [2]	DESCRIPTION [3]	ALY PIN [4]
EHRPWM_SOCA	O	EHRPWM Start of Conversion A	AE37
EHRPWM_SOCB	O	EHRPWM Start of Conversion B	AD34
EHRPWM_TZn_IN0	I	EHRPWM Trip Zone Input 0 (active low)	AJ38
EHRPWM_TZn_IN1	I	EHRPWM Trip Zone Input 1 (active low)	AC32
EHRPWM_TZn_IN2	I	EHRPWM Trip Zone Input 2 (active low)	AK35
EHRPWM_TZn_IN3	I	EHRPWM Trip Zone Input 3 (active low)	AC35
EHRPWM_TZn_IN4	I	EHRPWM Trip Zone Input 4 (active low)	AF36
EHRPWM_TZn_IN5	I	EHRPWM Trip Zone Input 5 (active low)	AJ37

**表 6-77. EPWM0 Signal Descriptions**

SIGNAL NAME [1]	PIN TYPE [2]	DESCRIPTION [3]	ALY PIN [4]
EHRPWM0_A	IO	EHRPWM Output A	AA32, AE38, AM37
EHRPWM0_B	IO	EHRPWM Output B	AC38, AF38
EHRPWM0_SYNCI	I	Sync Input to EHRPWM module from an external pin	AH38
EHRPWM0_SYNCO	O	Sync Output to EHRPWM module to an external pin	AG37

**表 6-78. EPWM1 Signal Descriptions**

SIGNAL NAME [1]	PIN TYPE [2]	DESCRIPTION [3]	ALY PIN [4]
EHRPWM1_A	IO	EHRPWM Output A	AA33, AE36, AP38
EHRPWM1_B	IO	EHRPWM Output B	AB34, AC33

**表 6-79. EPWM2 Signal Descriptions**

SIGNAL NAME [1]	PIN TYPE [2]	DESCRIPTION [3]	ALY PIN [4]
EHRPWM2_A	IO	EHRPWM Output A	AB36, AF37, AN38

**表 6-79. EPWM2 Signal Descriptions (continued)**

SIGNAL NAME [1]	PIN TYPE [2]	DESCRIPTION [3]	ALY PIN [4]
EHRPWM2_B	IO	EHRPWM Output B	AB38, AK38

**表 6-80. EPWM3 Signal Descriptions**

SIGNAL NAME [1]	PIN TYPE [2]	DESCRIPTION [3]	ALY PIN [4]
EHRPWM3_A	IO	EHRPWM Output A	AC38, AE35, AM35
EHRPWM3_B	IO	EHRPWM Output B	AF35
EHRPWM3_SYNCI	I	Sync Input to EHRPWM module from an external pin	AH36
EHRPWM3_SYNCO	O	Sync Output to EHRPWM module to an external pin	AG35

**表 6-81. EPWM4 Signal Descriptions**

SIGNAL NAME [1]	PIN TYPE [2]	DESCRIPTION [3]	ALY PIN [4]
EHRPWM4_A	IO	EHRPWM Output A	AB34, AJ36, AM36
EHRPWM4_B	IO	EHRPWM Output B	AH37

**表 6-82. EPWM5 Signal Descriptions**

SIGNAL NAME [1]	PIN TYPE [2]	DESCRIPTION [3]	ALY PIN [4]
EHRPWM5_A	IO	EHRPWM Output A	AB38, AG38
EHRPWM5_B	IO	EHRPWM Output B	AK34

### 6.3.16 USB

#### 6.3.16.1 MAIN Domain

**表 6-83. USB0 Signal Descriptions**

SIGNAL NAME [1]	PIN TYPE [2]	DESCRIPTION [3]	ALY PIN [4]
USB0_DM	IO	USB 2.0 Differential Data (negative)	AP16
USB0_DP	IO	USB 2.0 Differential Data (positive)	AP17
USB0_DRVVBUS	O	USB VBUS Control Output (active high)	AE35, AL32, AN37
USB0_ID	A	USB 2.0 Dual-Role Device Role Select	AN17
USB0_RCALIB <sup>(1)</sup>	A	Pin to connect to calibration resistor	AN18
USB0_VBUS <sup>(2)</sup>	A	USB Level-shifted VBUS Detector	AN15
USB0_SSRX1N	I	SERDES_USB Differential Receive Data (negative)	AR11, AR17
USB0_SSRX1P	I	SERDES_USB Differential Receive Data (positive)	AR12, AR18
USB0_SSRX2N	I	SERDES_USB Differential Receive Data (negative)	AU11, AU17
USB0_SSRX2P	I	SERDES_USB Differential Receive Data (positive)	AU12, AU18
USB0_SSTX1N	O	SERDES_USB Differential Transmit Data (negative)	AT16, AV9
USB0_SSTX1P	O	SERDES_USB Differential Transmit Data (positive)	AT17, AV10
USB0_SSTX2N	O	SERDES_USB Differential Transmit Data (negative)	AV12, AV18
USB0_SSTX2P	O	SERDES_USB Differential Transmit Data (positive)	AV13, AV19

- (1) An external 500 Ω ±1% resistor must be connected between this pin and VSS, even when the pin is unused  
 (2) An external resistor divider is required to limit the voltage applied to the device pin. For more information, see *USB VBUS Design Guidelines*.

### 6.3.17 Display Port

#### 6.3.17.1 MAIN Domain

**表 6-84. DP0 Signal Descriptions**

SIGNAL NAME [1]	PIN TYPE [2]	DESCRIPTION [3]	ALY PIN [4]
DP0_AUXN	IO	Display Port Differential Auxiliary Data (negative)	AP22
DP0_AUXP	IO	Display Port Differential Auxiliary Data (positive)	AP23
DP0_HPD	I	Display Port Hot Plug Detection	AC34, AG33, AM37
DP0_TXN0	O	Display Port Differential Transmit (negative)	AP13
DP0_TXN1	O	Display Port Differential Transmit (negative)	AT13
DP0_TXN2	O	Display Port Differential Transmit (negative)	AT16
DP0_TXN3	O	Display Port Differential Transmit (negative)	AV18
DP0_TXP0	O	Display Port Differential Transmit (positive)	AP14
DP0_TXP1	O	Display Port Differential Transmit (positive)	AT14
DP0_TXP2	O	Display Port Differential Transmit (positive)	AT17
DP0_TXP3	O	Display Port Differential Transmit (positive)	AV19

### 6.3.18 Hyperlink

#### 6.3.18.1 MAIN Domain

**表 6-85. Hyperlink Signal Descriptions**

SIGNAL NAME [1]	PIN TYPE [2]	DESCRIPTION [3]	ALY PIN [4]
HYP_RXN0	I	Hyperlink RX (negative)	AR14, AR8
HYP_RXN1	I	Hyperlink RX (negative)	AT10, AU14
HYP_RXN2	I	Hyperlink RX (negative)	AR11, AR17
HYP_RXN3	I	Hyperlink RX (negative)	AU11, AU17
HYP_RXP0	I	Hyperlink RX (positive)	AR15, AR9
HYP_RXP1	I	Hyperlink RX (positive)	AT11, AU15
HYP_RXP2	I	Hyperlink RX (positive)	AR12, AR18
HYP_RXP3	I	Hyperlink RX (positive)	AU12, AU18
HYP_TXN0	O	Hyperlink TX0 (negative)	AP13, AT7
HYP_TXN1	O	Hyperlink TX0 (negative)	AP10, AT13
HYP_TXN2	O	Hyperlink TX0 (negative)	AT16, AV9
HYP_TXN3	O	Hyperlink TX0 (negative)	AV12, AV18
HYP_TXP0	O	Hyperlink TX0 (positive)	AP14, AT8
HYP_TXP1	O	Hyperlink TX0 (positive)	AP11, AT14
HYP_TXP2	O	Hyperlink TX0 (positive)	AT17, AV10
HYP_TXP3	O	Hyperlink TX0 (positive)	AV13, AV19

**表 6-86. Hyperlink0 Signal Descriptions**

SIGNAL NAME [1]	PIN TYPE [2]	DESCRIPTION [3]	ALY PIN [4]
HYP0_RXFLCLK	O	Hyperlink Flow Management Receive Clock	AK35
HYP0_RXFLDAT	O	Hyperlink Flow Management Receive Data	AK38
HYP0_RXPMCLK	I	Hyperlink Power Management Receive Clock	AC36
HYP0_RXPMDAT	I	Hyperlink Power Management Receive Data	AE36
HYP0_TXFLCLK	I	Hyperlink Flow Management Transmit Clock	AF37
HYP0_TXFLDAT	I	Hyperlink Flow Management Transmit Data	AG37
HYP0_TXPMCLK	O	Hyperlink Power Management Transmit Clock	AD37

**表 6-86. Hyperlink0 Signal Descriptions (continued)**

SIGNAL NAME [1]	PIN TYPE [2]	DESCRIPTION [3]	ALY PIN [4]
HYP0_TXPMDAT	O	Hyperlink Power Management Transmit Data	AE37

**表 6-87. Hyperlink1 Signal Descriptions**

SIGNAL NAME [1]	PIN TYPE [2]	DESCRIPTION [3]	ALY PIN [4]
HYP1_RXFLCLK	O	Hyperlink Flow Management Receive Clock	AK33
HYP1_RXFLDAT	O	Hyperlink Flow Management Receive Data	AK37
HYP1_RXPMCLK	I	Hyperlink Power Management Receive Clock	AC32
HYP1_RXPMDAT	I	Hyperlink Power Management Receive Data	AC37
HYP1_TXFLCLK	I	Hyperlink Flow Management Transmit Clock	AD36
HYP1_TXFLDAT	I	Hyperlink Flow Management Transmit Data	AJ32
HYP1_TXPMCLK	O	Hyperlink Power Management Transmit Clock	AJ37
HYP1_TXPMDAT	O	Hyperlink Power Management Transmit Data	AK34

### 6.3.19 PCIE

#### 6.3.19.1 MAIN Domain

**表 6-88. PCIE Signal Descriptions**

SIGNAL NAME [1]	PIN TYPE [2]	DESCRIPTION [3]	ALY PIN [4]
PCIE0_CLKREQn	IO	PCIE Clock Request Signal	AC34
PCIE1_CLKREQn	IO	PCIE Clock Request Signal	AC38, AR38
PCIE2_CLKREQn	IO	PCIE Clock Request Signal	AB38, AL33
PCIE3_CLKREQn	IO	PCIE Clock Request Signal	AB36, AL34
PCIE0_RXN0	I	SERDES_PCIE Differential Receive Data (negative)	AU5
PCIE0_RXN1	I	SERDES_PCIE Differential Receive Data (negative)	AT4
PCIE0_RXN2	I	SERDES_PCIE Differential Receive Data (negative)	AU2
PCIE0_RXN3	I	SERDES_PCIE Differential Receive Data (negative)	AT1
PCIE0_RXP0	I	SERDES_PCIE Differential Receive Data (positive)	AU6
PCIE0_RXP1	I	SERDES_PCIE Differential Receive Data (positive)	AT5
PCIE0_RXP2	I	SERDES_PCIE Differential Receive Data (positive)	AU3
PCIE0_RXP3	I	SERDES_PCIE Differential Receive Data (positive)	AT2
PCIE0_TXN0	O	SERDES_PCIE Differential Transmit Data (negative)	AV6
PCIE0_TXN1	O	SERDES_PCIE Differential Transmit Data (negative)	AR5
PCIE0_TXN2	O	SERDES_PCIE Differential Transmit Data (negative)	AR2
PCIE0_TXN3	O	SERDES_PCIE Differential Transmit Data (positive)	AP1
PCIE0_TXP0	O	SERDES_PCIE Differential Transmit Data (positive)	AV7
PCIE0_TXP1	O	SERDES_PCIE Differential Transmit Data (positive)	AR6
PCIE0_TXP2	O	SERDES_PCIE Differential Transmit Data (positive)	AR3
PCIE0_TXP3	O	SERDES_PCIE Differential Transmit Data (positive)	AP2
PCIE1_RXN0	I	SERDES_PCIE Differential Receive Data (negative)	AR8
PCIE1_RXN1	I	SERDES_PCIE Differential Receive Data (negative)	AT10
PCIE1_RXN2	I	SERDES_PCIE Differential Receive Data (negative)	AR11
PCIE1_RXN3	I	SERDES_PCIE Differential Receive Data (negative)	AU11
PCIE1_RXP0	I	SERDES_PCIE Differential Receive Data (positive)	AR9
PCIE1_RXP1	I	SERDES_PCIE Differential Receive Data (positive)	AT11
PCIE1_RXP2	I	SERDES_PCIE Differential Receive Data (positive)	AR12
PCIE1_RXP3	I	SERDES_PCIE Differential Receive Data (positive)	AU12



**表 6-88. PCIe Signal Descriptions (continued)**

SIGNAL NAME [1]	PIN TYPE [2]	DESCRIPTION [3]	ALY PIN [4]
PCIE1_TXN0	O	SERDES_PCIE Differential Transmit Data (negative)	AT7
PCIE1_TXN1	O	SERDES_PCIE Differential Transmit Data (negative)	AP10
PCIE1_TXN2	O	SERDES_PCIE Differential Transmit Data (negative)	AV9
PCIE1_TXN3	O	SERDES_PCIE Differential Transmit Data (negative)	AV12
PCIE1_TXP0	O	SERDES_PCIE Differential Transmit Data (positive)	AT8
PCIE1_TXP1	O	SERDES_PCIE Differential Transmit Data (positive)	AP11
PCIE1_TXP2	O	SERDES_PCIE Differential Transmit Data (positive)	AV10
PCIE1_TXP3	O	SERDES_PCIE Differential Transmit Data (positive)	AV13
PCIE2_RXN0	I	SERDES_PCIE Differential Receive Data (negative)	AU2
PCIE2_RXN1	I	SERDES_PCIE Differential Receive Data (negative)	AT1
PCIE2_RXP0	I	SERDES_PCIE Differential Receive Data (positive)	AU3
PCIE2_RXP1	I	SERDES_PCIE Differential Receive Data (positive)	AT2
PCIE2_TXN0	O	SERDES_PCIE Differential Transmit Data (negative)	AR2
PCIE2_TXN1	O	SERDES_PCIE Differential Transmit Data (negative)	AP1
PCIE2_TXP0	O	SERDES_PCIE Differential Transmit Data (negative)	AR3
PCIE2_TXP1	O	SERDES_PCIE Differential Transmit Data (positive)	AP2
PCIE3_RXN0	I	SERDES_PCIE Differential Receive Data (negative)	AR11
PCIE3_RXN1	I	SERDES_PCIE Differential Receive Data (negative)	AU11
PCIE3_RXP0	I	SERDES_PCIE Differential Receive Data (positive)	AR12
PCIE3_RXP1	I	SERDES_PCIE Differential Receive Data (positive)	AU12
PCIE3_TXN0	O	SERDES_PCIE Differential Transmit Data (negative)	AV9
PCIE3_TXN1	O	SERDES_PCIE Differential Transmit Data (negative)	AV12
PCIE3_TXP0	O	SERDES_PCIE Differential Transmit Data (positive)	AV10
PCIE3_TXP1	O	SERDES_PCIE Differential Transmit Data (positive)	AV13
PCIE_REFCLK0_N_OUT	O	SERDES_PCIE Reference Clock Negative	AP4
PCIE_REFCLK0_P_OUT	O	SERDES_PCIE Reference Clock Positive	AP5
PCIE_REFCLK1_N_OUT	O	SERDES_PCIE Reference Clock Out Negative	AN8
PCIE_REFCLK1_P_OUT	O	SERDES_PCIE Reference Clock Out Positive	AN9
PCIE_REFCLK2_N_OUT	O	SERDES_PCIE Reference Clock Out Negative	AN5
PCIE_REFCLK2_P_OUT	O	SERDES_PCIE Reference Clock Out Positive	AN6
PCIE_REFCLK3_N_OUT	O	SERDES_PCIE Reference Clock Out Negative	AP7
PCIE_REFCLK3_P_OUT	O	SERDES_PCIE Reference Clock Out Positive	AP8

### 6.3.20 SERDES

#### 6.3.20.1 MAIN Domain

**表 6-89. SERDES0 Signal Descriptions**

SIGNAL NAME [1]	PIN TYPE [2]	DESCRIPTION [3]	ALY PIN [4]
SERDES0_REFCLK_N	IO	Serdes Reference Clock Input/Output (negative)	AU9
SERDES0_REFCLK_P	IO	Serdes Reference Clock Input/Output (positive)	AU8
SERDES0_REXT <sup>(1)</sup>	I	External Calibration Resistor	AN11

(1) An external 3.01 kΩ ±1% resistor must be connected between this pin and VSS. No external voltage should be applied to this pin.

**表 6-90. SERDES1 Signal Descriptions**

SIGNAL NAME [1]	PIN TYPE [2]	DESCRIPTION [3]	ALY PIN [4]
SERDES1_REFCLK_N	IO	Serdes Reference Clock Input/Output (negative)	AV3

**表 6-90. SERDES1 Signal Descriptions (continued)**

SIGNAL NAME [1]	PIN TYPE [2]	DESCRIPTION [3]	ALY PIN [4]
SERDES1_REFCLK_P	IO	Serdes Reference Clock Input/Output (positive)	AV4
SERDES1_REXT <sup>(1)</sup>	I	External Calibration Resistor	AL9

(1) An external 3.01 kΩ ±1% resistor must be connected between this pin and VSS. No external voltage should be applied to this pin.

**表 6-91. SERDES2 Signal Descriptions**

SIGNAL NAME [1] <sup>(2)</sup>	PIN TYPE [2]	DESCRIPTION [3]	ALY PIN [4]
SERDES2_REFCLK_N	IO	Serdes Reference Clock Input/Output (negative)	AV21
SERDES2_REFCLK_P	IO	Serdes Reference Clock Input/Output (positive)	AV22
SERDES2_REXT <sup>(1)</sup>	IO	External Calibration Resistor	AL20

(1) An external 3.01 kΩ ±1% resistor must be connected between this pin and VSS. No external voltage should be applied to this pin.

(2) DDRSS2, DDRSS3, and SERDES2 are not available on the 27mm package variant of this SoC. DDRSS2/DDRSS3/SERDES2 should be avoided if software compatibility is desired with systems that use the 27mm package.

**表 6-92. SERDES4 Signal Descriptions**

SIGNAL NAME [1]	PIN TYPE [2]	DESCRIPTION [3]	ALY PIN [4]
SERDES4_REFCLK_N	IO	Serdes Reference Clock Input/Output (negative)	AV16
SERDES4_REFCLK_P	IO	Serdes Reference Clock Input/Output (positive)	AV15
SERDES4_REXT <sup>(1)</sup>	IO	External Calibration Resistor	AM19

(1) An external 3.01 kΩ ±1% resistor must be connected between this pin and VSS. No external voltage should be applied to this pin.

### 6.3.21 DSI

#### 6.3.21.1 MAIN Domain

**表 6-93. DSI0 Signal Descriptions**

SIGNAL NAME [1]	PIN TYPE [2]	DESCRIPTION [3]	ALY PIN [4]
CSI0_TXCLKN	O	CSI Differential Transmit Clock Output (negative)	AP26
CSI0_TXCLKP	O	CSI Differential Transmit Clock Output (positive)	AP25
CSI0_TXN0	O	CSI Differential Transmit Output (negative)	AU27
CSI0_TXN1	O	CSI Differential Transmit Output (negative)	AT26
CSI0_TXN2	O	CSI Differential Transmit Output (negative)	AR27
CSI0_TXN3	O	CSI Differential Transmit Output (negative)	AN24
CSI0_TXP0	O	CSI Differential Transmit Output (positive)	AU26
CSI0_TXP1	O	CSI Differential Transmit Output (positive)	AT25
CSI0_TXP2	O	CSI Differential Transmit Output (positive)	AR26
CSI0_TXP3	O	CSI Differential Transmit Output (positive)	AN23
DSI0_TXCLKN	O	DSI Transmit clock (negative)	AP26
DSI0_TXCLKP	O	DSI Transmit clock (positive)	AP25
DSI0_TXRCALIB <sup>(1)</sup>	A	DSI Transmit Calibration Resistor	AM24
DSI0_TXN0	IO	DSI Transmit (negative)	AU27
DSI0_TXN1	O	DSI Transmit (negative)	AT26
DSI0_TXN2	O	DSI Transmit (negative)	AR27
DSI0_TXN3	O	DSI Transmit (negative)	AN24
DSI0_TXP0	IO	DSI Transmit (positive)	AU26
DSI0_TXP1	O	DSI Transmit (positive)	AT25
DSI0_TXP2	O	DSI Transmit (positive)	AR26
DSI0_TXP3	O	DSI Transmit (positive)	AN23

(1) An external 500 Ω ±1% resistor must be connected between this pin and VSS, even when the pin is unused.

**表 6-94. DS11 Signal Descriptions**

SIGNAL NAME [1]	PIN TYPE [2]	DESCRIPTION [3]	ALY PIN [4]
CSI1_TXCLKN	O	CSI Differential Transmit Clock Output (negative)	AP29
CSI1_TXCLKP	O	CSI Differential Transmit Clock Output (positive)	AP28
CSI1_TXN0	O	CSI Differential Transmit Output (negative)	AT29
CSI1_TXN1	O	CSI Differential Transmit Output (negative)	AN27
CSI1_TXN2	O	CSI Differential Transmit Output (negative)	AV28
CSI1_TXN3	O	CSI Differential Transmit Output (negative)	AU30
CSI1_TXP0	O	CSI Differential Transmit Output (positive)	AT28
CSI1_TXP1	O	CSI Differential Transmit Output (positive)	AN26
CSI1_TXP2	O	CSI Differential Transmit Output (positive)	AV27
CSI1_TXP3	O	CSI Differential Transmit Output (positive)	AU29
DSI1_TXCLKN	O	DSI Transmit clock (negative)	AP29
DSI1_TXCLKP	O	DSI Transmit clock (positive)	AP28
DSI1_TXRCALIB (1)	A	DSI Transmit Calibration Resistor	AL22
DSI1_TXN0	IO	DSI Transmit (negative)	AT29
DSI1_TXN1	O	DSI Transmit (negative)	AN27
DSI1_TXN2	O	DSI Transmit (negative)	AV28
DSI1_TXN3	O	DSI Transmit (negative)	AU30
DSI1_TXP0	IO	DSI Transmit (positive)	AT28
DSI1_TXP1	O	DSI Transmit (positive)	AN26
DSI1_TXP2	O	DSI Transmit (positive)	AV27
DSI1_TXP3	O	DSI Transmit (positive)	AU29

(1) An external 500 Ω ±1% resistor must be connected between this pin and VSS, even when the pin is unused.

### 6.3.22 CSI

#### 6.3.22.1 MAIN Domain

**表 6-95. CSI0 Signal Descriptions**

SIGNAL NAME [1]	PIN TYPE [2]	DESCRIPTION [3]	ALY PIN [4]
CSI0_RXCLKN	I	CSI Differential Receive Clock Input (negative)	AN30
CSI0_RXCLKP	I	CSI Differential Receive Clock Input (positive)	AN29
CSI0_RXRCALIB (1)	A	CSI Pin connected to external resistor for on-chip resistor calibration	AM28
CSI0_RXN0	I	CSI Differential Receive Input (negative)	AU33
CSI0_RXN1	I	CSI Differential Receive Input (negative)	AT32
CSI0_RXN2	I	CSI Differential Receive Input (negative)	AV31
CSI0_RXN3	I	CSI Differential Receive Input (negative)	AR30
CSI0_RXP0	I	CSI Differential Receive Input (positive)	AU32
CSI0_RXP1	I	CSI Differential Receive Input (positive)	AT31
CSI0_RXP2	I	CSI Differential Receive Input (positive)	AV30
CSI0_RXP3	I	CSI Differential Receive Input (positive)	AR29

(1) An external 500 Ω ±1% resistor must be connected between this pin and VSS, even when the pin is unused.

**表 6-96. CSI1 Signal Descriptions**

SIGNAL NAME [1]	PIN TYPE [2]	DESCRIPTION [3]	ALY PIN [4]
CSI1_RXCLKN	I	CSI Differential Receive Clock Input (negative)	AP32
CSI1_RXCLKP	I	CSI Differential Receive Clock Input (positive)	AP31

**表 6-96. CSI1 Signal Descriptions (continued)**

SIGNAL NAME [1]	PIN TYPE [2]	DESCRIPTION [3]	ALY PIN [4]
CSI1_RXRCALIB <sup>(1)</sup>	A	CSI pin connected to external resistor for on-chip resistor calibration	AL28
CSI1_RXN0	I	CSI Differential Receive Input (negative)	AT35
CSI1_RXN1	I	CSI Differential Receive Input (negative)	AU36
CSI1_RXN2	I	CSI Differential Receive Input (negative)	AR33
CSI1_RXN3	I	CSI Differential Receive Input (negative)	AV34
CSI1_RXP0	I	CSI Differential Receive Input (positive)	AT34
CSI1_RXP1	I	CSI Differential Receive Input (positive)	AU35
CSI1_RXP2	I	CSI Differential Receive Input (positive)	AR32
CSI1_RXP3	I	CSI Differential Receive Input (positive)	AV33

(1) An external 500 Ω ±1% resistor must be connected between this pin and VSS, even when the pin is unused.

**表 6-97. CSI2 Signal Descriptions**

SIGNAL NAME [1]	PIN TYPE [2]	DESCRIPTION [3]	ALY PIN [4]
CSI2_RXCLKN	I	CSI Differential Receive Clock Input (negative)	AN32
CSI2_RXCLKP	I	CSI Differential Receive Clock Input (positive)	AN33
CSI2_RXRCALIB <sup>(1)</sup>	A	CSI Pin connected to external resistor for on-chip resistor calibration	AM31
CSI2_RXN0	I	CSI Differential Receive Input (negative)	AR36
CSI2_RXN1	I	CSI Differential Receive Input (negative)	AT38
CSI2_RXN2	I	CSI Differential Receive Input (negative)	AP35
CSI2_RXN3	I	CSI Differential Receive Input (negative)	AV37
CSI2_RXP0	I	CSI Differential Receive Input (positive)	AR35
CSI2_RXP1	I	CSI Differential Receive Input (positive)	AT37
CSI2_RXP2	I	CSI Differential Receive Input (positive)	AP34
CSI2_RXP3	I	CSI Differential Receive Input (positive)	AV36

(1) An external 500 Ω ±1% resistor must be connected between this pin and VSS, even when the pin is unused.

### 6.3.23 MCASP

#### 6.3.23.1 MAIN Domain

**表 6-98. MCASP0 Signal Descriptions**

SIGNAL NAME [1]	PIN TYPE [2]	DESCRIPTION [3]	ALY PIN [4]
MCASP0_ACLKR	IO	MCASP Receive Bit Clock	AF34
MCASP0_ACLKX	IO	MCASP Transmit Bit Clock	AK35
MCASP0_AFSR	IO	MCASP Receive Frame Sync	AE34
MCASP0_AFSX	IO	MCASP Transmit Frame Sync	AK38
MCASP0_AXR0	IO	MCASP Serial Data (Input/Output)	AF37
MCASP0_AXR1	IO	MCASP Serial Data (Input/Output)	AG37
MCASP0_AXR2	IO	MCASP Serial Data (Input/Output)	AK33
MCASP0_AXR3	IO	MCASP Serial Data (Input/Output)	AJ38
MCASP0_AXR4	IO	MCASP Serial Data (Input/Output)	AK34
MCASP0_AXR5	IO	MCASP Serial Data (Input/Output)	AG38
MCASP0_AXR6	IO	MCASP Serial Data (Input/Output)	AF36
MCASP0_AXR7	IO	MCASP Serial Data (Input/Output)	AE35
MCASP0_AXR8	IO	MCASP Serial Data (Input/Output)	AC35
MCASP0_AXR9	IO	MCASP Serial Data (Input/Output)	AG35

**表 6-98. MCASP0 Signal Descriptions (continued)**

SIGNAL NAME [1]	PIN TYPE [2]	DESCRIPTION [3]	ALY PIN [4]
MCASP0_AXR10	IO	MCASP Serial Data (Input/Output)	AH36
MCASP0_AXR11	IO	MCASP Serial Data (Input/Output)	AF35
MCASP0_AXR12	IO	MCASP Serial Data (Input/Output)	AD34
MCASP0_AXR13	IO	MCASP Serial Data (Input/Output)	AJ36
MCASP0_AXR14	IO	MCASP Serial Data (Input/Output)	AF34
MCASP0_AXR15	IO	MCASP Serial Data (Input/Output)	AE34

**表 6-99. MCASP1 Signal Descriptions**

SIGNAL NAME [1]	PIN TYPE [2]	DESCRIPTION [3]	ALY PIN [4]
MCASP1_ACLKR	IO	MCASP Receive Bit Clock	AG38
MCASP1_ACLKX	IO	MCASP Transmit Bit Clock	AC34
MCASP1_AFSR	IO	MCASP Receive Frame Sync	AF36
MCASP1_AFSX	IO	MCASP Transmit Frame Sync	AD33
MCASP1_AXR0	IO	MCASP Serial Data (Input/Output)	AD38
MCASP1_AXR1	IO	MCASP Serial Data (Input/Output)	AC32
MCASP1_AXR2	IO	MCASP Serial Data (Input/Output)	AC37
MCASP1_AXR3	IO	MCASP Serial Data (Input/Output)	AL33
MCASP1_AXR4	IO	MCASP Serial Data (Input/Output)	AL34

**表 6-100. MCASP2 Signal Descriptions**

SIGNAL NAME [1]	PIN TYPE [2]	DESCRIPTION [3]	ALY PIN [4]
MCASP2_ACLKR	IO	MCASP Receive Bit Clock	AD34
MCASP2_ACLKX	IO	MCASP Transmit Bit Clock	AD37
MCASP2_AFSR	IO	MCASP Receive Frame Sync	AJ36
MCASP2_AFSX	IO	MCASP Transmit Frame Sync	AE37
MCASP2_AXR0	IO	MCASP Serial Data (Input/Output)	AC36
MCASP2_AXR1	IO	MCASP Serial Data (Input/Output)	AE36
MCASP2_AXR2	IO	MCASP Serial Data (Input/Output)	AF38
MCASP2_AXR3	IO	MCASP Serial Data (Input/Output)	AC33
MCASP2_AXR4	IO	MCASP Serial Data (Input/Output)	AF34

**表 6-101. MCASP3 Signal Descriptions**

SIGNAL NAME [1]	PIN TYPE [2]	DESCRIPTION [3]	ALY PIN [4]
MCASP3_ACLKR	IO	MCASP Receive Bit Clock	AM37
MCASP3_ACLKX	IO	MCASP Transmit Bit Clock	AM37
MCASP3_AFSR	IO	MCASP Receive Frame Sync	AP38
MCASP3_AFSX	IO	MCASP Transmit Frame Sync	AP38
MCASP3_AXR0	IO	MCASP Serial Data (Input/Output)	AN38
MCASP3_AXR1	IO	MCASP Serial Data (Input/Output)	AM35
MCASP3_AXR2	IO	MCASP Serial Data (Input/Output)	AM36

**表 6-102. MCASP4 Signal Descriptions**

SIGNAL NAME [1]	PIN TYPE [2]	DESCRIPTION [3]	ALY PIN [4]
MCASP4_ACLKR	IO	MCASP Receive Bit Clock	AE35
MCASP4_ACLKX	IO	MCASP Transmit Bit Clock	AJ32

**表 6-102. MCASP4 Signal Descriptions (continued)**

SIGNAL NAME [1]	PIN TYPE [2]	DESCRIPTION [3]	ALY PIN [4]
MCASP4_AFSR	IO	MCASP Receive Frame Sync	AC35
MCASP4_AFSX	IO	MCASP Transmit Frame Sync	AJ37
MCASP4_AXR0	IO	MCASP Serial Data (Input/Output)	AJ34
MCASP4_AXR1	IO	MCASP Serial Data (Input/Output)	AE38
MCASP4_AXR2	IO	MCASP Serial Data (Input/Output)	AD36
MCASP4_AXR3	IO	MCASP Serial Data (Input/Output)	AH38
MCASP4_AXR4	IO	MCASPI Serial Data (Input/Output)	AG35

### 6.3.24 DMTIMER

#### 6.3.24.1 MAIN Domain

**表 6-103. DMTIMER Signal Descriptions**

SIGNAL NAME [1]	PIN TYPE [2]	DESCRIPTION [3]	ALY PIN [4]
TIMER_IO0	IO	Timer Inputs and Outputs (Can be used with any MAIN domain timer instance)	AR38
TIMER_IO1	IO	Timer Inputs and Outputs (Can be used with any MAIN domain timer instance)	AN37
TIMER_IO2	IO	Timer Inputs and Outputs (Can be used with any MAIN domain timer instance)	AC38
TIMER_IO3	IO	Timer Inputs and Outputs (Can be used with any MAIN domain timer instance)	AA32
TIMER_IO4	IO	Timer Inputs and Outputs (Can be used with any MAIN domain timer instance)	AB34
TIMER_IO5	IO	Timer Inputs and Outputs (Can be used with any MAIN domain timer instance)	AA33
TIMER_IO6	IO	Timer Inputs and Outputs (Can be used with any MAIN domain timer instance)	AB38
TIMER_IO7	IO	Timer Inputs and Outputs (Can be used with any MAIN domain timer instance)	AB36

#### 6.3.24.2 MCU Domain

**表 6-104. MCU\_DMTIMER Signal Descriptions**

SIGNAL NAME [1]	PIN TYPE [2]	DESCRIPTION [3]	ALY PIN [4]
MCU_TIMER_IO0	IO	Timer Inputs and Outputs (Can be used with any MCU domain timer instance.)	G33, J38
MCU_TIMER_IO1	IO	Timer Inputs and Outputs (Can be used with any MCU domain timer instance.)	F37, M38
MCU_TIMER_IO2	IO	Timer Inputs and Outputs (Can be used with any MCU domain timer instance.)	E38
MCU_TIMER_IO3	IO	Timer Inputs and Outputs (Can be used with any MCU domain timer instance.)	E37
MCU_TIMER_IO4	IO	Timer Inputs and Outputs (Can be used with any MCU domain timer instance.)	D36
MCU_TIMER_IO5	IO	Timer Inputs and Outputs (Can be used with any MCU domain timer instance.)	C36
MCU_TIMER_IO6	IO	Timer Inputs and Outputs (Can be used with any MCU domain timer instance.)	L35, M37
MCU_TIMER_IO7	IO	Timer Inputs and Outputs (Can be used with any MCU domain timer instance.)	L34, M36
MCU_TIMER_IO8	IO	Timer Inputs and Outputs (Can be used with any MCU domain timer instance.)	H37

**表 6-104. MCU\_DMTIMER Signal Descriptions (continued)**

SIGNAL NAME [1]	PIN TYPE [2]	DESCRIPTION [3]	ALY PIN [4]
MCU_TIMER_IO9	IO	Timer Inputs and Outputs (Can be used with any MCU domain timer instance.)	K37

### 6.3.25 CPTS

#### 6.3.25.1 MAIN Domain

**表 6-105. CPTS0 Signal Descriptions**

SIGNAL NAME [1]	PIN TYPE [2]	DESCRIPTION [3]	ALY PIN [4]
CPTS0_RFT_CLK	I	CPTS Reference Clock	AD36
CPTS0_TS_COMP	O	CPTS Time Stamp Counter Compare	AP38
CPTS0_TS_SYNC	O	CPTS Time Stamp Counter Bit	AA32
CPTS0_HW1TSPUSH	I	CPTS Hardware Time Stamp Push 1	AD36
CPTS0_HW2TSPUSH	I	CPTS Hardware Time Stamp Push 2	AJ32

#### 6.3.25.2 MCU Domain

**表 6-106. MCU\_CPTS0 Signal Descriptions**

SIGNAL NAME [1]	PIN TYPE [2]	DESCRIPTION [3]	ALY PIN [4]
MCU_CPTS0_RFT_CLK	I	CPTS Reference Clock	L33, M33
MCU_CPTS0_TS_COMP	O	CPTS Time Stamp Counter Compare	L34
MCU_CPTS0_TS_SYNC	O	CPTS Time Stamp Counter Bit	L35
MCU_CPTS0_HW1TSPUSH	I	CPTS Hardware Time Stamp Push 1	L37
MCU_CPTS0_HW2TSPUSH	I	CPTS Hardware Time Stamp Push 2	L36

### 6.3.26 DSS

#### 6.3.26.1 MAIN Domain

**表 6-107. DSS0 Signal Descriptions**

SIGNAL NAME [1]	PIN TYPE [2]	DESCRIPTION [3]	ALY PIN [4]
DSS_FSYNC0	O	Video Output Frame Sync	AG36, AJ37
DSS_FSYNC1	O	Video Output Frame Sync	AJ33, AJ34
DSS_FSYNC2	O	Video Output Frame Sync	AF33, AF35
DSS_FSYNC3	O	Video Output Frame Sync	AD34, AH33
VOU0_DE	O	Video Output Data Enable	AG38
VOU0_EXTPCLKIN	I	Video Output External Pixel Clock Input	AJ37
VOU0_HSYNC	O	Video Output Horizontal Sync	AK34
VOU0_PCLK	O	Video Output Pixel Clock Output	AH37
VOU0_VSYNC	O	Video Output Vertical Sync	AF36
VOU0_DATA0	O	Video Output Data 0	AC33
VOU0_DATA1	O	Video Output Data 1	AH38
VOU0_DATA2	O	Video Output Data 2	AJ38
VOU0_DATA3	O	Video Output Data 3	AE38
VOU0_DATA4	O	Video Output Data 4	AF38
VOU0_DATA5	O	Video Output Data 5	AE36
VOU0_DATA6	O	Video Output Data 6	AC36
VOU0_DATA7	O	Video Output Data 7	AE37
VOU0_DATA8	O	Video Output Data 8	AD37
VOU0_DATA9	O	Video Output Data 9	AC37

**表 6-107. DSS0 Signal Descriptions (continued)**

SIGNAL NAME [1]	PIN TYPE [2]	DESCRIPTION [3]	ALY PIN [4]
VOU0_DATA10	O	Video Output Data 10	AC32
VOU0_DATA11	O	Video Output Data 11	AK33
VOU0_DATA12	O	Video Output Data 12	AG37
VOU0_DATA13	O	Video Output Data 13	AF37
VOU0_DATA14	O	Video Output Data 14	AK38
VOU0_DATA15	O	Video Output Data 15	AK35
VOU0_DATA16	O	Video Output Data 16	AJ32
VOU0_DATA17	O	Video Output Data 17	AK37
VOU0_DATA18	O	Video Output Data 18	AC33, AL32
VOU0_DATA19	O	Video Output Data 19	AE33, AH38
VOU0_DATA20	O	Video Output Data 20	AD37, AH34
VOU0_DATA21	O	Video Output Data 21	AC37, AJ35
VOU0_DATA22	O	Video Output Data 22	AG34, AK37
VOU0_DATA23	O	Video Output Data 23	AD36, AK36
VOU0_VP0_DE	O	Alternative Output Data Enable	AG38
VOU0_VP0_HSYNC	O	Alternative Output Horizontal Sync	AK34
VOU0_VP0_VSYNC	O	Alternative Output Vertical Sync	AF36
VOU0_VP2_DE	O	Alternative Output Data Enable	AG38
VOU0_VP2_HSYNC	O	Alternative Output Horizontal Sync	AK34
VOU0_VP2_VSYNC	O	Alternative Output Vertical Sync	AF36

### 6.3.27 GPMC

#### 6.3.27.1 MAIN Domain

**表 6-108. GPMC0 Signal Descriptions**

SIGNAL NAME [1]	PIN TYPE [2]	DESCRIPTION [3]	ALY PIN [4]
GPMC0_ADVn_ALE	O	GPMC Address Valid (active low) or Address Latch Enable	AK33
GPMC0_CLK	IO	GPMC clock	AG36
GPMC0_CLKOUT	O	GPMC clock generated for external synchronization	AF36
GPMC0_DIR	O	GPMC Data Bus Signal Direction Control	AC33, AH37
GPMC0_OEn_REn	O	GPMC Output Enable (active low) or Read Enable (active low)	AK34
GPMC0_WEn	O	GPMC Write Enable (active low)	AJ34
GPMC0_WPn	O	GPMC Flash Write Protect (active low)	AK33
GPMC0_A0	OZ	GPMC Address 0 Output. Only used to effectively address 8-bit data non-multiplexed memories	AE35
GPMC0_A1	OZ	GPMC Address 1 Output in A/D non-multiplexed mode and Address 17 in A/D multiplexed mode	AC35
GPMC0_A2	OZ	GPMC Address 2 Output in A/D non-multiplexed mode and Address 18 in A/D multiplexed mode	AG35
GPMC0_A3	OZ	GPMC Address 3 Output in A/D non-multiplexed mode and Address 19 in A/D multiplexed mode	AH36
GPMC0_A4	OZ	GPMC Address 4 Output in A/D non-multiplexed mode and Address 20 in A/D multiplexed mode	AF35
GPMC0_A5	OZ	GPMC Address 5 Output in A/D non-multiplexed mode and Address 21 in A/D multiplexed mode	AD34
GPMC0_A6	OZ	GPMC Address 6 Output in A/D non-multiplexed mode and Address 22 in A/D multiplexed mode	AJ36



**表 6-108. GPMC0 Signal Descriptions (continued)**

SIGNAL NAME [1]	PIN TYPE [2]	DESCRIPTION [3]	ALY PIN [4]
GPMC0_A7	OZ	GPMC Address 7 Output in A/D non-multiplexed mode and Address 23 in A/D multiplexed mode	AF34
GPMC0_A8	OZ	GPMC Address 8 Output in A/D non-multiplexed mode and Address 24 in A/D multiplexed mode	AE34
GPMC0_A9	OZ	GPMC Address 9 Output in A/D non-multiplexed mode and Address 25 in A/D multiplexed mode	AL33
GPMC0_A10	OZ	GPMC Address 10 Output in A/D non-multiplexed mode and Address 26 in A/D multiplexed mode	AL34
GPMC0_A11	OZ	GPMC Address 11 Output in A/D non-multiplexed mode and unused in A/D multiplexed mode	AC34
GPMC0_A12	OZ	GPMC Address 12 Output in A/D non-multiplexed mode and unused in A/D multiplexed mode	AD33
GPMC0_A13	OZ	GPMC Address 13 Output in A/D non-multiplexed mode and unused in A/D multiplexed mode	AD38
GPMC0_A14	OZ	GPMC Address 14 Output in A/D non-multiplexed mode and unused in A/D multiplexed mode	AE35, AL32
GPMC0_A15	OZ	GPMC Address 15 Output in A/D non-multiplexed mode and unused in A/D multiplexed mode	AE33
GPMC0_A16	OZ	GPMC Address 16 Output in A/D non-multiplexed mode and unused in A/D multiplexed mode	AH34
GPMC0_A17	OZ	GPMC Address 17 Output in A/D non-multiplexed mode and unused in A/D multiplexed mode	AJ35
GPMC0_A18	OZ	GPMC Address 18 Output in A/D non-multiplexed mode and unused in A/D multiplexed mode	AG34
GPMC0_A19	OZ	GPMC Address 19 Output in A/D non-multiplexed mode and unused in A/D multiplexed mode	AK36
GPMC0_A20	OZ	GPMC Address 20 Output in A/D non-multiplexed mode and unused in A/D multiplexed mode	AG33
GPMC0_A21	OZ	GPMC Address 21 Output in A/D non-multiplexed mode and unused in A/D multiplexed mode	AH33
GPMC0_A22	OZ	GPMC Address 22 Output in A/D non-multiplexed mode and unused in A/D multiplexed mode	AF33
GPMC0_A23	OZ	GPMC Address 23 Output in A/D non-multiplexed mode and unused in A/D multiplexed mode	AJ33
GPMC0_A24	OZ	GPMC Address 24 Output in A/D non-multiplexed mode and unused in A/D multiplexed mode	AG36
GPMC0_AD0	IO	GPMC Data 0 Input/Output in A/D non-multiplexed mode and additionally Address 1 Output in A/D multiplexed mode	AK35
GPMC0_AD1	IO	GPMC Data 1 Input/Output in A/D non-multiplexed mode and additionally Address 2 Output in A/D multiplexed mode	AK38
GPMC0_AD2	IO	GPMC Data 2 Input/Output in A/D non-multiplexed mode and additionally Address 3 Output in A/D multiplexed mode	AF37
GPMC0_AD3	IO	GPMC Data 3 Input/Output in A/D non-multiplexed mode and additionally Address 4 Output in A/D multiplexed mode	AG37
GPMC0_AD4	IO	GPMC Data 4 Input/Output in A/D non-multiplexed mode and additionally Address 5 Output in A/D multiplexed mode	AK37
GPMC0_AD5	IO	GPMC Data 5 Input/Output in A/D non-multiplexed mode and additionally Address 6 Output in A/D multiplexed mode	AD36

**表 6-108. GPMC0 Signal Descriptions (continued)**

SIGNAL NAME [1]	PIN TYPE [2]	DESCRIPTION [3]	ALY PIN [4]
GPMC0_AD6	IO	GPMC Data 6 Input/Output in A/D non-multiplexed mode and additionally Address 7 Output in A/D multiplexed mode	AJ32
GPMC0_AD7	IO	GPMC Data 7 Input/Output in A/D non-multiplexed mode and additionally Address 8 Output in A/D multiplexed mode	AJ37
GPMC0_AD8	IO	GPMC Data 8 Input/Output in A/D non-multiplexed mode and additionally Address 9 Output in A/D multiplexed mode	AC32
GPMC0_AD9	IO	GPMC Data 9 Input/Output in A/D non-multiplexed mode and additionally Address 10 Output in A/D multiplexed mode	AC37
GPMC0_AD10	IO	GPMC Data 10 Input/Output in A/D non-multiplexed mode and additionally Address 11 Output in A/D multiplexed mode	AD37
GPMC0_AD11	IO	GPMC Data 11 Input/Output in A/D non-multiplexed mode and additionally Address 12 Output in A/D multiplexed mode	AE37
GPMC0_AD12	IO	GPMC Data 12 Input/Output in A/D non-multiplexed mode and additionally Address 13 Output in A/D multiplexed mode	AC36
GPMC0_AD13	IO	GPMC Data 13 Input/Output in A/D non-multiplexed mode and additionally Address 14 Output in A/D multiplexed mode	AE36
GPMC0_AD14	IO	GPMC Data 14 Input/Output in A/D non-multiplexed mode and additionally Address 15 Output in A/D multiplexed mode	AF38
GPMC0_AD15	IO	GPMC Data 15 Input/Output in A/D non-multiplexed mode and additionally Address 16 Output in A/D multiplexed mode	AE38
GPMC0_BE0n_CLE	O	GPMC Lower-Byte Enable (active low) or Command Latch Enable	AH38
GPMC0_BE1n	O	GPMC Upper-Byte Enable (active low)	AJ38
GPMC0_CSn0	O	GPMC Chip Select 0 (active low)	AG38
GPMC0_CSn1	O	GPMC Chip Select 1 (active low)	AH37
GPMC0_CSn2	O	GPMC Chip Select 2 (active low)	AE35, AL32
GPMC0_CSn3	O	GPMC Chip Select 3 (active low)	AJ33
GPMC0_WAIT0	I	GPMC External Indication of Wait	AC33
GPMC0_WAIT1	I	GPMC External Indication of Wait	AE33
GPMC0_WAIT2	I	GPMC External Indication of Wait	AF33
GPMC0_WAIT3	I	GPMC External Indication of Wait	AD38

### 6.3.28 MMC

#### 6.3.28.1 MAIN Domain

**表 6-109. MMC0 Signal Descriptions**

SIGNAL NAME [1]	PIN TYPE [2]	DESCRIPTION [3]	ALY PIN [4]
MMC0_CALPAD <sup>(1)</sup>	A	MMC/SD/SDIO Calibration Resistor	AJ7
MMC0_CLK	O	MMC/SD/SDIO Clock	AK5
MMC0_CMD	IO	MMC/SD/SDIO Command	AL8
MMC0_DS	IO	MMC Data Strobe	AK4
MMC0_DAT0	IO	MMC/SD/SDIO Data	AK9

表 6-109. MMC0 Signal Descriptions (continued)

SIGNAL NAME [1]	PIN TYPE [2]	DESCRIPTION [3]	ALY PIN [4]
MMC0_DAT1	IO	MMC/SD/SDIO Data	AL6
MMC0_DAT2	IO	MMC/SD/SDIO Data	AK8
MMC0_DAT3	IO	MMC/SD/SDIO Data	AK6
MMC0_DAT4	IO	MMC/SD/SDIO Data	AK7
MMC0_DAT5	IO	MMC/SD/SDIO Data	AL7
MMC0_DAT6	IO	MMC/SD/SDIO Data	AL5
MMC0_DAT7	IO	MMC/SD/SDIO Data	AK3

(1) An external 10 kΩ ±1% resistor must be connected between this pin and VSS. No external voltage should be applied to this pin.

表 6-110. MMC1 Signal Descriptions

SIGNAL NAME [1]	PIN TYPE [2]	DESCRIPTION [3]	ALY PIN [4]
MMC1_CLK (2)	IO	MMC/SD/SDIO Clock	AB38
MMC1_CMD	IO	MMC/SD/SDIO Command	AB36
MMC1_SDCD (1)	I	SD Card Detect	AR38
MMC1_SDWP	I	SD Write Protect	AN37
MMC1_DAT0	IO	MMC/SD/SDIO Data	AA33
MMC1_DAT1	IO	MMC/SD/SDIO Data	AB34
MMC1_DAT2	IO	MMC/SD/SDIO Data	AA32
MMC1_DAT3	IO	MMC/SD/SDIO Data	AC38

- (1) For ROM boot from MMC1 interface to work properly, the MMC1\_SDCD pin should be pulled low externally with a resistor to indicate an SD Card/Memory device is present.
- (2) For MMC1\_CLK signal to work properly, the RXACTIVE bit of the CTRLMMR\_PADCONFIG171 register should be set to 0x1 because of retiming purposes.

### 6.3.29 OSPI

#### 6.3.29.1 MCU Domain

表 6-111. MCU\_OSPI0 Signal Descriptions

SIGNAL NAME [1]	PIN TYPE [2]	DESCRIPTION [3]	ALY PIN [4]
MCU_OSPI0_CLK	O	OSPI Clock	E32
MCU_OSPI0_DQS	I	OSPI Data Strobe (DQS) or Loopback Clock Input	C34
MCU_OSPI0_ECC_FAIL	I	OSPI ECC Status	C32, F31
MCU_OSPI0_LBCLKO	IO	OSPI Loopback Clock Output	D32
MCU_OSPI0_CSn0	O	OSPI Chip Select 0 (active low)	A32
MCU_OSPI0_CSn1	O	OSPI Chip Select 1 (active low)	A33
MCU_OSPI0_CSn2	O	OSPI Chip Select 2 (active low)	B34, C31
MCU_OSPI0_CSn3	O	OSPI Chip Select 3 (active low)	C32, F31
MCU_OSPI0_D0	IO	OSPI Data 0	B33
MCU_OSPI0_D1	IO	OSPI Data 1	B32
MCU_OSPI0_D2	IO	OSPI Data 2	C33
MCU_OSPI0_D3	IO	OSPI Data 3	C35
MCU_OSPI0_D4	IO	OSPI Data 4	D33
MCU_OSPI0_D5	IO	OSPI Data 5	D34
MCU_OSPI0_D6	IO	OSPI Data 6	E34
MCU_OSPI0_D7	IO	OSPI Data 7	E33
MCU_OSPI0_RESET_OUT0	O	OSPI Reset	B34, C31

**表 6-111. MCU\_OSPI0 Signal Descriptions (continued)**

SIGNAL NAME [1]	PIN TYPE [2]	DESCRIPTION [3]	ALY PIN [4]
MCU_OSPI0_RESET_OUT1	O	OSPI Reset	C32, G33

**表 6-112. MCU\_OSPI1 Signal Descriptions**

SIGNAL NAME [1]	PIN TYPE [2]	DESCRIPTION [3]	ALY PIN [4]
MCU_OSPI1_CLK	O	OSPI Clock	F32
MCU_OSPI1_DQS	I	OSPI Data Strobe (DQS) or Loopback Clock Input	F31
MCU_OSPI1_LBCLKO	IO	OSPI Loopback Clock Output	C31
MCU_OSPI1_CSn0	O	OSPI Chip Select 0 (active low)	G32
MCU_OSPI1_CSn1	O	OSPI Chip Select 1 (active low)	G33
MCU_OSPI1_D0	IO	OSPI Data 0	E35
MCU_OSPI1_D1	IO	OSPI Data 1	D31
MCU_OSPI1_D2	IO	OSPI Data 2	G31
MCU_OSPI1_D3	IO	OSPI Data 3	F33

### 6.3.30 Hyperbus

#### 6.3.30.1 MCU Domain

**表 6-113. MCU\_HYPERBUS0 Signal Descriptions**

SIGNAL NAME [1]	PIN TYPE [2]	DESCRIPTION [3]	ALY PIN [4]
MCU_HYPERBUS0_CK	O	Hyperbus Differential Clock (positive)	E32
MCU_HYPERBUS0_CKn	O	Hyperbus Differential Clock (negative)	D32
MCU_HYPERBUS0_INTn	I	Hyperbus Interrupt (active low)	C32, F31
MCU_HYPERBUS0_RESETn	O	Hyperbus Reset (active low) Output	A33
MCU_HYPERBUS0_RESETOn	I	Hyperbus Reset Status Indicator (active low) from Hyperbus Memory	B34, C31
MCU_HYPERBUS0_RWDS	IO	Hyperbus Read-Write Data Strobe	C34
MCU_HYPERBUS0_WPn	O	Hyperbus Write Protect (Not in use)	B34, C32, G33
MCU_HYPERBUS0_CSn0	O	Hyperbus Chip Select 0	A32
MCU_HYPERBUS0_CSn1	O	Hyperbus Chip Select 1	B34, G33
MCU_HYPERBUS0_DQ0	IO	Hyperbus Data 0	B33
MCU_HYPERBUS0_DQ1	IO	Hyperbus Data 1	B32
MCU_HYPERBUS0_DQ2	IO	Hyperbus Data 2	C33
MCU_HYPERBUS0_DQ3	IO	Hyperbus Data 3	C35
MCU_HYPERBUS0_DQ4	IO	Hyperbus Data 4	D33
MCU_HYPERBUS0_DQ5	IO	Hyperbus Data 5	D34
MCU_HYPERBUS0_DQ6	IO	Hyperbus Data 6	E34
MCU_HYPERBUS0_DQ7	IO	Hyperbus Data 7	E33

### 6.3.31 Emulation and Debug

#### 6.3.31.1 MAIN Domain

**表 6-114. JTAG Signal Descriptions**

SIGNAL NAME [1]	PIN TYPE [2]	DESCRIPTION [3]	ALY PIN [4]
EMU0	IO	Emulation Control 0	F35
EMU1	IO	Emulation Control 1	H34
TCK	I	JTAG Test Clock Input	G35
TDI	I	JTAG Test Data Input	AL37

**表 6-114. JTAG Signal Descriptions (continued)**

SIGNAL NAME [1]	PIN TYPE [2]	DESCRIPTION [3]	ALY PIN [4]
TDO	OZ	JTAG Test Data Output	AL35
TMS	I	JTAG Test Mode Select Input	AL36
TRSTn	I	JTAG Reset	G37

**表 6-115. Trace Signal Descriptions**

SIGNAL NAME [1]	PIN TYPE [2]	DESCRIPTION [3]	ALY PIN [4]
TRC_CLK	O	Trace Clock	AG36, AJ32
TRC_CTL	O	Trace Control	AJ33, AJ37
TRC_DATA0	O	Trace Data 0	AF33, AJ34
TRC_DATA1	O	Trace Data 1	AD36, AH33
TRC_DATA2	O	Trace Data 2	AG33, AK37
TRC_DATA3	O	Trace Data 3	AC33, AK36
TRC_DATA4	O	Trace Data 4	AD37
TRC_DATA5	O	Trace Data 5	AH38
TRC_DATA6	O	Trace Data 6	AC37
TRC_DATA7	O	Trace Data 7	AJ38
TRC_DATA8	O	Trace Data 8	AC32
TRC_DATA9	O	Trace Data 9	AE37
TRC_DATA10	O	Trace Data 10	AK33
TRC_DATA11	O	Trace Data 11	AF38
TRC_DATA12	O	Trace Data 12	AG37
TRC_DATA13	O	Trace Data 13	AE36
TRC_DATA14	O	Trace Data 14	AF37
TRC_DATA15	O	Trace Data 15	AC36
TRC_DATA16	O	Trace Data 16	AE38
TRC_DATA17	O	Trace Data 17	AH37
TRC_DATA18	O	Trace Data 18	AK34
TRC_DATA19	O	Trace Data 19	AG38
TRC_DATA20	O	Trace Data 20	AF36
TRC_DATA21	O	Trace Data 21	AG34
TRC_DATA22	O	Trace Data 22	AJ35
TRC_DATA23	O	Trace Data 23	AH34
TRC_DATA24	O	Trace Data 24	AE33
TRC_DATA25	O	Trace Data 25	AL32

### 6.3.32 System and Miscellaneous

#### 6.3.32.1 Boot Mode configuration

**表 6-116. Sysboot Signal Descriptions**

SIGNAL NAME [1]	PIN TYPE [2]	DESCRIPTION [3]	ALY PIN [4]
BOOTMODE00	I	Bootmode Pin 0	B33
BOOTMODE01	I	Bootmode Pin 1	B32
BOOTMODE02	I	Bootmode Pin 2	D33
BOOTMODE03	I	Bootmode Pin 3	D34
BOOTMODE04	I	Bootmode Pin 4	M37
BOOTMODE05	I	Bootmode Pin 5	M36

**表 6-116. Sysboot Signal Descriptions (continued)**

SIGNAL NAME [1]	PIN TYPE [2]	DESCRIPTION [3]	ALY PIN [4]
BOOTMODE06	I	Bootmode Pin 6	N34
BOOTMODE07	I	Bootmode Pin 7	M34
MCU_BOOTMODE00	I	MCU Bootmode Pin 0	G38
MCU_BOOTMODE01	I	MCU Bootmode Pin 1	H36
MCU_BOOTMODE02	I	MCU Bootmode Pin 2	J38
MCU_BOOTMODE03	I	MCU Bootmode Pin 3	H38
MCU_BOOTMODE04	I	MCU Bootmode Pin 4	J34
MCU_BOOTMODE05	I	MCU Bootmode Pin 5	J35
MCU_BOOTMODE06	I	MCU Bootmode Pin 6	H37
MCU_BOOTMODE07	I	MCU Bootmode Pin 7	K37
MCU_BOOTMODE08	I	MCU Bootmode Pin 8	J37
MCU_BOOTMODE09	I	MCU Bootmode Pin 9	K38

### 6.3.32.2 Clock

**表 6-117. Clock0 Signal Descriptions**

SIGNAL NAME [1]	PIN TYPE [2]	DESCRIPTION [3]	ALY PIN [4]
WKUP_LF_CLKIN	I	Low Frequency (32.768 KHz) Oscillator Input	M34
WKUP_OSC0_XI	I	High Frequency Oscillator Input	T38
WKUP_OSC0_XO	O	High Frequency Oscillator Output	U37

**表 6-118. Clock1 Signal Descriptions**

SIGNAL NAME [1]	PIN TYPE [2]	DESCRIPTION [3]	ALY PIN [4]
OSC1_XI	I	High Frequency Oscillator Input	P38
OSC1_XO	O	High Frequency Oscillator Output	N37

### 6.3.32.3 System

**表 6-119. MCU System Signal Descriptions**

SIGNAL NAME [1]	PIN TYPE [2]	DESCRIPTION [3]	ALY PIN [4]
MCU_CLKOUT0	OZ	Reference clock output for Ethernet PHYs (50MHz or 25MHz)	M38
MCU_EXT_REFCLK0	I	External system clock input	L33, M33
MCU_OBSCLK0	O	Observation clock output for test and debug purposes only	H34, M38
MCU_PORz	I	MCU Domain Cold Reset	K32
MCU_RESETSTATz	O	MCU Domain Warm Reset status output	F36
MCU_RESETz	I	MCU Domain Warm Reset	G36
MCU_SAFETY_ERRORn	IO	Error signal output from MCU Domain ESM	N36
MCU_SYSCLKOUT0	O	MCU Domain system clock output for test and debug purposes only	L33

**表 6-120. System Signal Descriptions**

SIGNAL NAME [1]	PIN TYPE [2]	DESCRIPTION [3]	ALY PIN [4]
AUDIO_EXT_REFCLK0	IO	External clock routed to ATL or McASP as one of the selectable input clock sources, or as a output clock output for ATL or McASP	AJ34

**表 6-120. System Signal Descriptions (continued)**

SIGNAL NAME [1]	PIN TYPE [2]	DESCRIPTION [3]	ALY PIN [4]
AUDIO_EXT_REFCLK1	IO	External clock routed to ATL or McASP as one of the selectable input clock sources, or as a output clock output for ATL or McASP	AH37
EXTINTn	I	External Interrupt	AN35
EXT_REFCLK1	I	External clock input to Main Domain, routed to Timer clock muxes as one of the selectable input clock sources for Timer/WDT modules, or as reference clock to MAIN_PLL2 (PER1 PLL)	AJ32
GPMC0_FCLK_MUX	O	GPMC functional clock output selected through a mux logic	AF36
OBSCLK0	O	Observation clock output for test and debug purposes only	AN37
OBSCLK1	O	Observation clock output for test and debug purposes only	AG37
PMIC_POWER_EN1	O	Power enable output for MAIN Domain supplies	L38
PMIC_WAKE0n	O	PMIC WakeUp	AJ34
PMIC_WAKE1n	O	PMIC WakeUp	M33
PORz	I	SoC PORz Reset Signal	P33
RESETSTATz	O	Main Domain Warm Reset status output	AL38
RESET_REQz	I	Main Domain external Warm Reset request input	F34
SOC_SAFETY_ERRORn	IO	Error signal output from Main Domain ESM	AM34
SYNC0_OUT	O	CPTS Time Stamp Generator Bit 0	AD36
SYNC1_OUT	O	CPTS Time Stamp Generator Bit 1	AJ32
SYNC2_OUT	O	CPTS Time Stamp Generator Bit 2	AD38
SYNC3_OUT	O	CPTS Time Stamp Generator Bit 3	AD37
SYSCLKOUT0	O	SYSCLK0 output from Main PLL controller (divided by 6) for test and debug purposes only	AR38

### 6.3.32.4 EFUSE

**表 6-121. EFUSE Signal Descriptions**

SIGNAL NAME [1]	PIN TYPE [2]	DESCRIPTION [3]	ALY PIN [4]
VPP_CORE		Programming Voltage for MAIN Domain Efuses	AA31
VPP_MCU		Programming Voltage for MCU Domain Efuses	L29

### 6.3.32.5 VMON

**表 6-122. VMON Signal Descriptions**

SIGNAL NAME [1]	PIN TYPE [2]	DESCRIPTION [3]	ALY PIN [4]
VMON1_ER_VSYS		Voltage Monitor, fixed 0.45V (+/-3%) threshold. Use with external precision voltage divider to monitor a higher voltage rail such as the PMIC input supply.	K28
VMON2_IR_VCPU		Must be externally connected directly to VDD_CPU	N27
VMON3_IR_VEXT1P8		General purpose voltage monitor for external supplies, 1.8V threshold. With internal resistor divider.	J30
VMON4_IR_VEXT1P8		General purpose voltage monitor for external supplies, 1.8V threshold. With internal resistor divider.	P28
VMON5_IR_VEXT3P3		General purpose voltage monitor for external supplies, 3.3V threshold. With internal resistor divider.	R29

### 6.3.33 Power

**表 6-123. Power Supply Signal Descriptions**

SIGNAL NAME [1]	PIN TYPE [2]	DESCRIPTION [3]	ALY PIN [4]
CAP_VDDSD0 <sup>(1)</sup>	CAP	External Capacitor Connection	V29
CAP_VDDSD0_MCU <sup>(1)</sup>	CAP	External Capacitor Connection	L27
CAP_VDDSD1_MCU <sup>(1)</sup>	CAP	External Capacitor Connection	L25
CAP_VDDSD2 <sup>(1)</sup>	CAP	External Capacitor Connection	T29
CAP_VDDSD2_MCU <sup>(1)</sup>	CAP	External Capacitor Connection	L26
CAP_VDDSD5 <sup>(1)</sup>	CAP	External Capacitor Connection	P29
VDDAR_CORE	PWR	Core RAM Supply	AB27, AC24, AF15, AF18, AF21, AG11, AG28, T25
VDDAR_CPU	PWR	CPU RAM Supply	AB13, AC16, AC18, AC20, AE12, M21, N23, T15, U20, W14, W21, Y11, Y19
VDDAR_MCU	PWR	MCU RAM Supply	M27, N24
VDDA_0P8_DSITX	PWR	Analog Supply for DSITX	AJ24
VDDA_0P8_DSITX_C	PWR	DSITX Clock Supply	AJ25
VDDA_0P8_UFS	PWR	UFS 0.8V Supply	AH11
VDDA_0P8_USB	PWR	USB 0.8V Supply	AK20
VDDA_0P8_CSIRX2	PWR	Analog Supply for CSIRX	AJ28
VDDA_0P8_CSIRX0_1	PWR	Analog Supply for CSIRX	AJ26, AK26
VDDA_0P8_DLL_MMC0	PWR	MMC DLL Analog Supply	AE9
VDDA_0P8_PLL_DDR0	PWR	DDR de-skew PLL Analog Supply	U11
VDDA_0P8_PLL_DDR1	PWR	DDR de-skew PLL Analog Supply	M14
VDDA_0P8_PLL_DDR2	PWR	DDR de-skew PLL Analog Supply	N11
VDDA_0P8_PLL_DDR3	PWR	DDR de-skew PLL Analog Supply	M18
VDDA_0P8_SERDES2	PWR	SERDES 0.8V Supply	AJ20, AJ21
VDDA_0P8_SERDES4	PWR	SERDES 0.8V Supply	AJ17, AJ18
VDDA_0P8_SERDES0_1	PWR	SERDES 0.8V Supply	AJ12, AJ15, AK13, AK14
VDDA_0P8_SERDES_C2	PWR	SERDES 0.8V Clock Supply	AG21, AH20
VDDA_0P8_SERDES_C4	PWR	SERDES 0.8V Clock Supply	AG17, AH18
VDDA_0P8_SERDES_C0_1	PWR	SERDES 0.8V Clock Supply	AH12, AH13, AH15, AH16
VDDA_1P8_DSITX	PWR	Analog Supply for DSITX	AH24, AH25
VDDA_1P8_UFS	PWR	UFS 1.8V Supply	AJ10
VDDA_1P8_USB	PWR	USB 1.8V Supply	AK21
VDDA_1P8_CSIRX2	PWR	Analog Supply for CSIRX	AH29, AJ29
VDDA_1P8_CSIRX0_1	PWR	Analog Supply for CSIRX	AH27, AH28
VDDA_1P8_SERDES2	PWR	SERDES 1.8V Supply	AH21
VDDA_1P8_SERDES4	PWR	SERDES 1.8V Supply	AH17
VDDA_1P8_SERDES0_1	PWR	SERDES 1.8V Supply	AJ13, AJ14
VDDA_1P8_SERDES2_4	PWR	SERDES 1.8V Supply	AJ23
VDDA_3P3_USB	PWR	USB 3.3V Supply	AJ19
VDDA_ADC0	PWR	ADC0 Analog Supply	M31
VDDA_ADC1	PWR	ADC1 Analog Supply	N30
VDDA_MCU_PLLGRP0	PWR	Analog Supply for MCU PLL Group 0	M28
VDDA_MCU_TEMP	PWR	Analog Supply for MCU temperature sensor	M26
VDDA_OSC1	PWR	HFOSC1 Supply	N29

ADVANCE INFORMATION



**表 6-123. Power Supply Signal Descriptions (continued)**

SIGNAL NAME [1]	PIN TYPE [2]	DESCRIPTION [3]	ALY PIN [4]
VDDA_PLLGRP0	PWR	Analog Supply for MAIN PLL Group 0	AA27
VDDA_PLLGRP1	PWR	Analog Supply for MAIN PLL Group 1	Y28
VDDA_PLLGRP2	PWR	Analog Supply for MAIN PLL Group 2	AG13
VDDA_PLLGRP5	PWR	Analog Supply for MAIN PLL Group 5	V14
VDDA_PLLGRP6	PWR	Analog Supply for MAIN PLL Group 6	R21
VDDA_PLLGRP7	PWR	Analog Supply for MAIN PLL Group 7	P12
VDDA_PLLGRP8	PWR	Analog Supply for MAIN PLL Group 8	P15
VDDA_PLLGRP9	PWR	Analog Supply for MAIN PLL Group 9	Y26
VDDA_PLLGRP10	PWR	Analog Supply for MAIN PLL Group 10	AG23
VDDA_PLLGRP12	PWR	Analog Supply for MAIN PLL Group 12	AA23
VDDA_PLLGRP13	PWR	Analog Supply for MAIN PLL Group 13	AB26
VDDA_POR_WKUP	PWR	WKUP domain Analog Supply	N28
VDDA_TEMP0	PWR	Analog Supply for temperature sensor 0	Y27
VDDA_TEMP1	PWR	Analog Supply for temperature sensor 1	M12
VDDA_TEMP2	PWR	Analog Supply for temperature sensor 2	W23
VDDA_TEMP3	PWR	Analog Supply for temperature sensor 3	AE13
VDDA_TEMP4	PWR	Analog Supply for temperature sensor 4	AD18
VDDA_WKUP	PWR	Oscillator Supply for WKUP domain	K31, L32
VDDSHV0	PWR	IO Power Supply	V30, V32, W31
VDDSHV0_MCU	PWR	IO Power Supply	H29, J28, K29
VDDSHV1_MCU	PWR	IO Power Supply	H25, J24, K25
VDDSHV2	PWR	IO Power Supply	T30, T32, U31
VDDSHV2_MCU	PWR	IO Power Supply	H27, J26, K27
VDDSHV5	PWR	IO Power Supply	P31, R30, R31
VDDS_DDR	PWR	DDR PHY IO Supply	A31, AK1, B1, H11, H13, H15, H17, H19, H9, J10, J12, J14, J16, J18, J8, K11, K13, K15, K17, K19, K9, L10, L12, L14, L16, L18, M9, N10, N8, P9, R10, R8, T9, U10, U8
VDDS_DDR_C0	PWR	IO Power Supply for DDR Clock	T10
VDDS_DDR_C1	PWR	IO Power Supply for DDR Clock	L15
VDDS_DDR_C2	PWR	IO Power Supply for DDR Clock	M10
VDDS_DDR_C3	PWR	IO Power Supply for DDR Clock	L17
VDDS_MMC0	PWR	MMC0 PHY IO Supply	AF9, AG10, AG8, AH9

表 6-123. Power Supply Signal Descriptions (continued)

SIGNAL NAME [1]	PIN TYPE [2]	DESCRIPTION [3]	ALY PIN [4]
VDD_CORE	PWR	MAIN domain core Supply	AA24, AA26, AA28, AA30, AB25, AB29, AB31, AC26, AC28, AC30, AD25, AD27, AD29, AD31, AE24, AE26, AE28, AE30, AE32, AF13, AF17, AF19, AF23, AF25, AF27, AF29, AF31, AG12, AG14, AG16, AG18, AG20, AG22, AG24, AG26, AG30, AG32, AH31, AJ30, M11, M13, M15, M17, M19, N12, N16, N18, P11, P17, P19, R12, R14, R16, R18, R24, R26, R28, T11, T13, T27, U12, U24, U26, U28, V25, V27, W24, W26, W28, W30, W32, Y25, Y29, Y31
VDD_CPU	PWR	CPU core Supply	AA10, AA12, AA14, AA20, AA22, AA8, AB11, AB19, AB21, AB23, AB9, AC10, AC12, AC14, AC22, AD11, AD13, AD15, AD17, AD19, AD21, AD23, AD9, AE10, AE14, AE16, AE18, AE20, AE22, AF11, H21, H23, J20, J22, K21, K23, L20, L22, N20, N22, P21, R20, R22, T17, T19, T21, T23, U14, U22, V11, V13, V19, V21, V23, V9, W10, W12, W20, W22, W8, Y13, Y21, Y23, Y9
VDD_MCU	PWR	MCU core Supply	L24, M23, M25, N26, P23, P25, P27
VDD_MCU_WAKE1	PWR	Core Supply for MCU daisy chain	L28
VDD_WAKE0	PWR	Core Supply for MAIN domain daisy chain	U29

ADVANCE INFORMATION

**表 6-123. Power Supply Signal Descriptions (continued)**

SIGNAL NAME [1]	PIN TYPE [2]	DESCRIPTION [3]	ALY PIN [4]
VSS	GND	Ground	A1, A10, A12, A15, A2, A20, A23, A25, A28, A34, A37, A5, A7, AA11, AA13, AA19, AA2, AA21, AA25, AA29, AA34, AA36, AA38, AA5, AA9, AB1, AB10, AB12, AB14, AB20, AB22, AB24, AB28, AB30, AB32, AB33, AB35, AB37, AB5, AB8, AC11, AC13, AC15, AC17, AC19, AC2, AC21, AC23, AC25, AC27, AC29, AC31, AC6, AC9, AD1, AD10, AD12, AD14, AD16, AD20, AD22, AD24, AD26, AD28, AD30, AD32, AD35, AD4, AD8, AE11, AE15, AE17, AE19, AE2, AE21, AE23, AE25, AE27, AE29, AE31, AE5, AF10, AF12, AF14, AF16, AF20, AF22, AF24, AF26, AF28, AF3, AF30, AF32, AF6, AF8, AG1, AG15, AG19, AG25, AG27, AG29, AG31, AG4, AG7, AG9, AH10, AH14, AH19, AH2, AH22, AH23, AH26, AH30, AH32, AH35, AH5, AH8, AJ11, AJ16, AJ22, AJ27, AJ3, AJ31, AJ6, AJ8, AJ9, AK10, AK11, AK12, AK15, AK16, AK17, AK18, AK19, AK22, AK23, AK24, AK25, AK27, AK28, AK30, AK32, AL1, AL10, AL12, AL13, AL14, AL15, AL16, AL17, AL18, AL19, AL21, AL26, AL29, AL31, AL4, AM11, AM13, AM15, AM18, AM20, AM23, AM25, AM27, AM3, AM30, AM32, AM38, AM6, AN1, AN10, AN12, AN14, AN16, AN19, AN22, AN25, AN28, AN31, AN34, AN4, AN7, AP12, AP15, AP18, AP21, AP24, AP27, AP3, AP30, AP33, AP36, AP6, AP9, AR1, AR10, AR13, AR16, AR19, AR22, AR25, AR28, AR31, AR34, AR37, AR4, AR7, AT12, AT15, AT18, AT21, AT24, AT27, AT3, AT30, AT33, AT36, AT6, AT9, AU1, AU10, AU13, AU16, AU19, AU22, AU25, AU28, AU31, AU34, AU37, AU38, AU4, AU7, AV1, AV11, AV14, AV17, AV2, AV20, AV23, AV26, AV29, AV32, AV35, AV5, AV8, B11, B13, B16, B19,

**ADVANCE INFORMATION**

表 6-123. Power Supply Signal Descriptions (continued)

SIGNAL NAME [1]	PIN TYPE [2]	DESCRIPTION [3]	ALY PIN [4]
			B22, B24, B26, B29, B31, B38, B6, B9, C14, C17, C18, C2, C21, C27, C30, C4, C8, D10, D15, D20, D23, D28, D3, D35, D6, D7, E12, E13, E16, E19, E2, E22, E25, E26, E29, E31, E5, E9, F1, F11, F14, F17, F21, F24, F27, F30, F4, F7, F8, G15, G18, G20, G28, G3, G6, H10, H16, H18, H2, H20, H22, H24, H26, H28, H30, H31, H5, H7, H8, J1, J11, J13, J15, J17, J19, J21, J23, J25, J27, J29, J32, J4, J9, K10, K12, K14, K16, K18, K2, K20, K22, K24, K26, K6, K8, L1, L11, L13, L19, L21, L23, L31, L5, L9, M16, M2, M20, M22, M24, M29, M30, M32, M5, M8, N15, N17, N19, N21, N25, N3, N31, N32, N38, N6, N9, P1, P10, P16, P18, P20, P22, P24, P26, P30, P32, P35, P37, P4, P7, P8, R11, R13, R15, R17, R19, R2, R23, R25, R27, R32, R34, R36, R38, R5, R9, T12, T14, T16, T18, T20, T22, T24, T26, T28, T3, T31, T33, T35, T37, T6, T8, U13, U19, U21, U23, U25, U27, U3, U30, U32, U34, U36, U38, U6, U9, V10, V12, V2, V20, V22, V24, V26, V28, V31, V33, V35, V37, V5, V8, W1, W11, W13, W19, W25, W27, W29, W34, W36, W38, W4, W7, W9, Y10, Y12, Y14, Y20, Y22, Y24, Y3, Y30, Y32, Y33, Y35, Y37, Y6, Y8

(1) This pin must always be connected via a 1- $\mu$ F  $\pm$ 10% capacitor to VSS.

## 6.4 Pin Connectivity Requirements

This section describes connectivity requirements for package balls that have specific connectivity requirements and unused package balls.

注

All power balls must be supplied with the voltages specified in the [Recommended Operating Conditions](#) section, unless otherwise specified in [Signal Descriptions](#).

注

For additional clarification, "leave unconnected" or "no connect" (NC) means no signal traces can be connected to these device ball number.

ADVANCE INFORMATION

表 6-124 shows the connectivity requirements for specific signals by ball name and ball number.

**表 6-124. Connectivity Requirements**

BALL NUMBER	BALL NAME	CONNECTION REQUIREMENT
P38	OSC1_XI	Each of these balls must be connected to VSS through a separate external pull resistor to ensure these balls are held to a valid logic low-level, if unused.
T38	WKUP_OSC0_XI	
G37	TRSTN	
U1	DDR0_DQS0P	
AA1	DDR0_DQS1P	
AF1	DDR0_DQS2P	
AJ1	DDR0_DQS3P	
A16	DDR1_DQS0P	
A13	DDR1_DQS1P	
A8	DDR1_DQS2P	
A3	DDR1_DQS3P	
T1	DDR2_DQS0P	
N1	DDR2_DQS1P	
H1	DDR2_DQS2P	
E1	DDR2_DQS3P	
A18	DDR3_DQS0P	
A21	DDR3_DQS1P	
A26	DDR3_DQS2P	
A29	DDR3_DQS3P	
AC8	DDR0_RET	
G8	DDR1_RET	
L8	DDR2_RET	
G27	DDR3_RET	
K28	VMON1_ER_VSYS	
N27	VMON2_IR_VCPU	
J30	VMON3_IR_VEXT1P8	
P28	VMON4_IR_VEXT1P8	
R29	VMON5_IR_VEXT3P3	

**表 6-124. Connectivity Requirements (continued)**

BALL NUMBER	BALL NAME	CONNECTION REQUIREMENT
P36	MCU_ADC0_AIN0	Each of these balls can be connected to VSS through a separate external pull resistor or can be connected directly to VSS to ensure these balls are held to a valid logic low-level, if unused.
V36	MCU_ADC0_AIN1	
T34	MCU_ADC0_AIN2	
T36	MCU_ADC0_AIN3	
P34	MCU_ADC0_AIN4	
R37	MCU_ADC0_AIN5	
R33	MCU_ADC0_AIN6	
V38	MCU_ADC0_AIN7	
Y38	MCU_ADC1_AIN0	
Y34	MCU_ADC1_AIN1	
V34	MCU_ADC1_AIN2	
W37	MCU_ADC1_AIN3	
AA37	MCU_ADC1_AIN4	
W33	MCU_ADC1_AIN5	
U33	MCU_ADC1_AIN6	
Y36	MCU_ADC1_AIN7	
AN11	SERDES0_REXT	
AL9	SERDES1_REXT	
AL20	SERDES2_REXT	
AM19	SERDES4_REXT	
AM28	CSI0_RXRCALIB	
AL28	CSI1_RXRCALIB	
AM31	CSI2_RXRCALIB	
AE8	DDR0_CAL0	
G14	DDR1_CAL0	
U7	DDR2_CAL0	
F18	DDR3_CAL0	
AM24	DSI0_TXRCALIB	
AL22	DSI1_TXRCALIB	
AN18	USB0_RCALIB	

ADVANCE INFORMATION

**表 6-124. Connectivity Requirements (continued)**

BALL NUMBER	BALL NAME	CONNECTION REQUIREMENT
G36	MCU_RESETZ	Each of these balls must be connected to the corresponding power supply through a separate external pull resistor to ensure these balls are held to a valid logic high level, if unused.
K32	MCU_PORZ	
P33	PORZ	
F34	RESET_REQZ	
G35	TCK	
AL36	TMS	
G34	MCU_I2C0_SDA	
M35	MCU_I2C0_SCL	
N33	WKUP_I2C0_SCL	
N35	WKUP_I2C0_SDA	
AN36	I2C0_SCL	
AP37	I2C0_SDA	
AN35	EXTINTN	
AL37	TDI	
AL35	TDO	
F35	EMU0	
H34	EMU1	
V1	DDR0_DQS0N	
Y1	DDR0_DQS1N	
AE1	DDR0_DQS2N	
AH1	DDR0_DQS3N	
A17	DDR1_DQS0N	
A14	DDR1_DQS1N	
A9	DDR1_DQS2N	
A4	DDR1_DQS3N	
R1	DDR2_DQS0N	
M1	DDR2_DQS1N	
G1	DDR2_DQS2N	
D1	DDR2_DQS3N	
A19	DDR3_DQS0N	
A22	DDR3_DQS1N	
A27	DDR3_DQS2N	
A30	DDR3_DQS3N	
R35	MCU_ADC0_REFP	If the MCU_ADCn interface is not used, these signals should be connected to the same power supply as the VDDA_ADCn supply input.
AA35	MCU_ADC1_REFP	
U35	MCU_ADC0_REFN	If the MCU_ADCn interface is not used, these signals should be connected to VSS.
W35	MCU_ADC1_REFN	
L29	VPP_MCU	Each of these balls must be left unconnected, if unused.
AA31	VPP_CORE	
AJ7	MMC0_CALPAD	
	DDR0_*	DDRSS0, DDRSS1, DDRSS2 and DDRSS3 must always be used in incremental order. For instance, when using a single LPDDR component, it must be connected to the DDR0_* interface. When using two LPDDR components, they must be connected to DDR0_* and DDR1_* interfaces, and so forth.
	DDR1_*	
	DDR2_*	
	DDR3_*	

表 6-125 shows the specific connection requirements for the RESERVED ball numbers on the device.

注

For additional clarification, "left unconnected" or "no connect" (NC) means **no** signal traces can be connected to these device ball numbers.

**表 6-125. Reserved Balls Specific Connection Requirements (AHP)**

BALL NUMBERS	CONNECTION REQUIREMENTS
AF7 / AK2 / AK29 / AK31 / AL11 / AL23 / AL24 / AL25 / AL27 / AL30 / AM10 / AM12 / AM14 / AM16 / AM17 / AM21 / AM22 / AM26 / AM29 / AM33 / AM9 / AN13 / AN20 / AN21 / G17 / G22 / G30 / H12 / H14 / H32 / H33 / J31 / J33 / K30 / L30 / N7 / T7 / Y7	RESERVED. These balls must be left unconnected.



## 7 Specifications

### 7.1 Absolute Maximum Ratings

over operating free-air temperature range (unless otherwise noted)<sup>(1) (2)</sup>

PARAMETER		MIN	MAX	UNIT	
VDD_* <sup>(3)</sup>	Core supplies	-0.3	1.05	V	
VDDAR_* <sup>(3)</sup>	RAM supplies	-0.3	1.05	V	
VDDA_0P8_* <sup>(3)</sup>	Analog supplies for 0.8V domains	-0.3	1.05	V	
VDDA_1P8_* <sup>(3)</sup>	Analog supplies for 1.8 V PHY domains	-0.3	2.2	V	
VDDA_3P3_USB	Analog supply for 3.3V USB domain	-0.3	3.8	V	
VDDA_* <sup>(3)</sup>	Analog supply for 1.8V PLL and other domains	-0.3	2.2	V	
VDDS_DDR_* <sup>(3)</sup>	DDR interface power supplies	-0.3	1.2	V	
VDDS_MMC0	MMC0 IO supply	-0.3	2.2	V	
VDDSHV* <sup>(3)</sup>	Dual Voltage LVCMOS IO supplies	1.8 V	-0.3	2.2	V
		3.3 V	-0.3	3.8	V
VPP_CORE VPP MCU	Supply voltage range for EFUSE domains	-0.3	1.89	V	
USB0_VBUS <sup>(9)</sup>	Voltage range for USB VBUS comparator input	-0.3	3.6	V	
Steady State Max. Voltage at all fail-safe IO pins	I2C0_SCL, I2C0_SDA, WKUP_I2C0_SCL, WKUP_I2C0_SDA, MCU_I2C0_SCL, MCU_I2C0_SDA, EXTINTn	-0.3	3.8	V	
	MCU_PORz, PORz	-0.3	3.8	V	
Steady State Max. Voltage at all other IO pins <sup>(4)</sup>	VMON1_ER_VSYS <sup>(8)</sup> , VMON3_IR_VEXT1P8, VMON4_IR_VEXT1P8	-0.3	2.2	V	
	VMON2_IR_VCPU	-0.3	1.05	V	
	VMON5_IR_VEXT3P3	-0.3	3.8	V	
	All other IO pins	-0.3	IO supply voltage + 0.3	V	
Transient Overshoot and Undershoot specification at IO pin	20% of IO supply voltage for up to 20% of signal period ☒ 7-1 (see IO Transient Voltage Ranges)		0.2 × VDD <sup>(7)</sup>	V	
Latch-up Performance, Class II (125°C) <sup>(5)</sup>	I-Test	-100	100	mA	
	Over-Voltage (OV) Test	NA	1.5 × VDD <sup>(7)</sup>	V	
T <sub>STG</sub> <sup>(6)</sup>	Storage temperature	-55	+150	°C	

(1) Operation outside the Absolute Maximum Ratings may cause permanent device damage. Absolute Maximum Ratings do not imply functional operation of the device at these or any other conditions beyond those listed under [Recommended Operating Conditions](#). If used outside the Recommended Operating Conditions but within the Absolute Maximum Ratings, the device may not be fully functional, and this may affect device reliability, functionality, performance, and shorten the device lifetime.

- (2) All voltage values are with respect to their associated VSS or VSSA\_x, unless otherwise noted.
- (3) **VDD\_\* includes:** VDD\_CORE, VDD\_CPU, VDD\_MCU, VDD\_MCU\_WAKE1, VDD\_WAKE0  
**VDDAR\_\* includes:** VDDAR\_CORE, VDDAR\_CPU, VDDAR\_MCU  
**VDDA\_0P8\_\* includes:** VDDA\_0P8\_CSIRX0\_1, VDDA\_0P8\_CSIRX2, VDDA\_0P8\_DLL\_MMCO, VDDA\_0P8\_DSITX, VDDA\_0P8\_DSITX\_C, VDDA\_0P8\_PLL\_DDR0, VDDA\_0P8\_PLL\_DDR1, VDDA\_0P8\_PLL\_DDR2, VDDA\_0P8\_PLL\_DDR3, VDDA\_0P8\_SERDES\_C0\_1, VDDA\_0P8\_SERDES\_C2, VDDA\_0P8\_SERDES\_C4, VDDA\_0P8\_SERDES0\_1, VDDA\_0P8\_SERDES2, VDDA\_0P8\_SERDES4, VDDA\_0P8\_UFS, VDDA\_0P8\_USB  
**VDDA\_1P8\_\* includes:** VDDA\_1P8\_CSIRX0\_1, VDDA\_1P8\_CSIRX2, VDDA\_1P8\_DSITX, VDDA\_1P8\_SERDES0\_1, VDDA\_1P8\_SERDES2, VDDA\_1P8\_SERDES2\_4, VDDA\_1P8\_SERDES4, VDDA\_1P8\_UFS, VDDA\_1P8\_USB  
**VDDA\_\* includes:** VDDA\_ADC0, VDDA\_ADC1, VDDA\_MCU\_PLLGRP0, VDDA\_MCU\_TEMP, VDDA\_OSC1, VDDA\_PLLGRP0, VDDA\_PLLGRP1, VDDA\_PLLGRP10, VDDA\_PLLGRP12, VDDA\_PLLGRP13, VDDA\_PLLGRP2, VDDA\_PLLGRP5, VDDA\_PLLGRP6, VDDA\_PLLGRP7, VDDA\_PLLGRP8, VDDA\_PLLGRP9, VDDA\_POR\_WKUP, VDDA\_TEMP0, VDDA\_TEMP1, VDDA\_TEMP2, VDDA\_TEMP3, VDDA\_TEMP4, VDDA\_WKUP  
**VDDS\_DDR\_\* includes:** VDDS\_DDR, VDDS\_DDR\_C0, VDDS\_DDR\_C1, VDDS\_DDR\_C2, VDDS\_DDR\_C3  
**VDDSHV\* includes:** VDDSHV0, VDDSHV0\_MCU, VDDSHV1\_MCU, VDDSHV2, VDDSHV2\_MCU, VDDSHV5
- (4) This parameter applies to all IO pins which are not fail-safe and the requirement applies to all values of IO supply voltage. For example, if the voltage applied to a specific IO supply is 0 volts the valid input voltage range for any IO powered by that supply will be –0.3 to +0.3 volts. Special attention should be applied anytime peripheral devices are not powered from the same power sources used to power the respective IO supply. It is important the attached peripheral never sources a voltage outside the valid input voltage range, including power supply ramp-up and ramp-down sequences.
- (5) For current pulse injection:  
Pins stressed per JEDEC JESD78E (Class II) and passed with specified I/O pin injection current and clamp voltage of 1.5 times maximum recommended I/O voltage and negative 0.5 times maximum recommended I/O voltage.  
For overvoltage performance:  
Supplies stressed per JEDEC JESD78E (Class II) and passed specified voltage injection.
- (6) For tape and reel the storage temperature range is [–10°C; +50°C] with a maximum relative humidity of 70%. TI recommends returning to ambient room temperature before usage.
- (7) VDD is the voltage on the corresponding power-supply pin(s) for the IO.
- (8) The VMON\_ER\_VSYS pin provides a way to monitor the system power supply. For more information, see [System Power Supply Monitor Design Guidelines using VMON/POK](#).
- (9) An external resistor divider is required to limit the voltage applied to this device pin. For more information, see the [USB VBUS Design Guidelines](#).

Fail-safe IO terminals are designed such they do not have dependencies on the respective IO power supply voltage. This allows external voltage sources to be connected to these IO terminals when the respective IO power supplies are turned off. The I2C0\_SCL, I2C0\_SDA, I2C1\_SCL, I2C1\_SDA, DDR\_FS\_RESETn, and NMIIn are the only fail-safe IO terminals. All other IO terminals are not fail-safe and the voltage applied to them should be limited to the value defined by the Steady State Max. Voltage at all IO pins parameter in [Absolute Maximum Ratings](#).

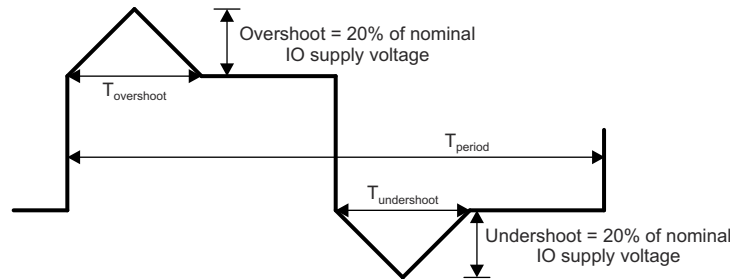

A.  $T_{overshoot} + T_{undershoot} < 20\% \text{ of } T_{period}$

7-1. IO Transient Voltage Ranges

## 7.2 ESD Ratings

			VALUE	UNIT	
V <sub>(ESD)</sub>	Electrostatic discharge	Human-body model (HBM), per AEC Q100-002 <sup>(1)</sup>	±1000	V	
		Charged-device model (CDM), per AEC Q100-011	All pins		±250
			Corner pins (A1, AJ29)		±750

(1) AEC Q100-002 indicates that HBM stressing shall be in accordance with the ANSI/ESDA/JEDEC JS-001 specification.

### 7.3 Power-On-Hour (POH) Limits

IP <sup>(1)</sup> (2) (3)	VOLTAGE DOMAIN	VOLTAGE (V) (MAX)	FREQUENCY (MHz) (MAX)	Tj(°C)	POH
All	100%	All	All Supported OPPs	Automotive -40°C to 125°C <sup>(4)</sup>	20000
All	100%	All	All Supported OPPs	Extended -40°C to 105°C	100000
All	100%	All	All Supported OPPs	Commercial 0°C to 90°C	100000

- (1) The information in the section below is provided solely for your convenience and does not extend or modify the warranty provided under TI's standard terms and conditions for TI semiconductor products.
- (2) Unless specified in the table above, all voltage domains and operating conditions are supported in the device at the noted temperatures
- (3) POH is a functional of voltage, temperature and time. Usage at higher voltages and temperatures will result in a reduction in POH to achieve the same reliability performance. For assessment of alternate use cases, contact your local TI representative.
- (4) Automotive profile is defined as 20000 power on hours with junction temperature as follows: 5%@-40°C, 65%@70°C, 20%@110°C, 10%@125°C.

### 7.4 Recommended Operating Conditions

over operating free-air temperature range (unless otherwise noted)

SUPPLY NAME	DESCRIPTION	MIN <sup>(1)</sup>	NOM	MAX <sup>(1)</sup>	UNIT	
VDD_CORE	Boot/Active voltage for MAIN domain core supply	0.76 <sup>(1)</sup>	0.8	0.84 <sup>(1)</sup>	V	
VDD_MCU	Boot/Active voltage for MCUSS core supply	0.76 <sup>(1)</sup>	0.8	0.89 <sup>(1)</sup>	V	
VDD_CPU	Boot voltage for CPU core supply, applied at cold power up event	0.76 <sup>(1)</sup>	0.8	0.84 <sup>(1)</sup>	V	
	Active voltage for CPU core supply, after AVS mode enabled in software	AVS <sup>(3)</sup> -5% <sup>(1)</sup>	AVS <sup>(3)</sup>	AVS <sup>(3)</sup> +5% <sup>(1)</sup>	V	
VDD_CPU AVS Range	AVS valid voltage range for VDD_CPU	0.6		0.9	V	
VDDAR_*( <sup>5</sup> )	RAM supplis	0.81	0.85	0.89	V	
VDDA_0P8_*( <sup>5</sup> )	Analog supplies for 0.8V domains	0.76	0.8	0.84	V	
VDDA_1P8_*( <sup>5</sup> )	Analog supplies for 1.8V PHY domains	1.71	1.8	1.89	V	
VDDA_3P3_USB( <sup>5</sup> )	Analog supply for 3.3V USB domain	3.14	3.3	3.46	V	
VDDA_*( <sup>5</sup> )	Analog supply for 1.8V PLL and other domains	1.71	1.8	1.89	V	
VDDA_*	Peak to Peak Noise for all VDDA inputs			25	mV	
VDDS_DDR_*( <sup>5</sup> )	DDR interface power supply	1.06	1.1	1.15	V	
VDDS_MMC0	MMC0 IO supply	1.8-V operation	1.71	1.8	1.89	V
		3.3-V operation	3.14	3.3	3.46	V
USB_VBUS	Voltage range for USB VBUS comparator input	0	See <sup>(4)</sup>	3.46	V	
USB_ID	Voltage range for the USB ID input		See <sup>(2)</sup>		V	
VSS	Ground		0		V	
Tj	Operating junction temperature range	Automotive	-40	125	°C	
		Extended	-40	105	°C	
		Commercial	0	90	°C	

- (1) For all VDD\* supply inputs, the voltage at the device ball must never be below the MIN voltage or above the MAX voltage for any amount of time. This requirement includes dynamic voltage events such as AC ripple, voltage transients, voltage dips, and so forth. This is required for all supply inputs, but special care should be given to the VDD\_CORE, VDD\_MCU, and VDD\_CPU domains which have higher transient current demand compared to other rails.
- (2) This terminal is connected to analog circuits in the respective USB PHY. The circuit sources a known current while measuring the voltage to determine if the terminal is connected to VSS with a resistance less than 10 Ω or greater than 100 kΩ. The terminal should be connected to ground for USB host operation or open-circuit for USB peripheral operation, and should never be connected to any external voltage source.
- (3) The AVS Voltages are device-dependent, voltage domain-dependent, and OPP-dependent. They must be read from the VTM\_DEVINFO\_VDn. For information about VTM\_DEVINFO\_VDn Registers address, please refer to Voltage and Thermal Manager section in the device TRM. The power supply should be adjustable over the ranges shown in the VDD\_CPU AVS Range entry.

- (4) An external resistor divider is required to limit the voltage applied to this device pin. For more information, see [USB VBUS Design Guidelines](#).
- (5) **VDD\_\* includes:** VDD\_CORE, VDD\_CPU, VDD\_MCU, VDD\_MCU\_WAKE1, VDD\_WAKE0  
**VDDAR\_\* includes:** VDDAR\_CORE, VDDAR\_CPU, VDDAR\_MCU  
**VDDA\_0P8\_\* includes:** VDDA\_0P8\_CSIRX0\_1, VDDA\_0P8\_CSIRX2, VDDA\_0P8\_DLL\_MMC0, VDDA\_0P8\_DSITX, VDDA\_0P8\_DSITX\_C, VDDA\_0P8\_PLL\_DDR0, VDDA\_0P8\_PLL\_DDR1, VDDA\_0P8\_PLL\_DDR2, VDDA\_0P8\_PLL\_DDR3, VDDA\_0P8\_SERDES\_C0\_1, VDDA\_0P8\_SERDES\_C2, VDDA\_0P8\_SERDES\_C4, VDDA\_0P8\_SERDES0\_1, VDDA\_0P8\_SERDES2, VDDA\_0P8\_SERDES4, VDDA\_0P8\_UFS, VDDA\_0P8\_USB  
**VDDA\_1P8\_\* includes:** VDDA\_1P8\_CSIRX0\_1, VDDA\_1P8\_CSIRX2, VDDA\_1P8\_DSITX, VDDA\_1P8\_SERDES0\_1, VDDA\_1P8\_SERDES2, VDDA\_1P8\_SERDES2\_4, VDDA\_1P8\_SERDES4, VDDA\_1P8\_UFS, VDDA\_1P8\_USB  
**VDDA\_\* includes:** VDDA\_ADC0, VDDA\_ADC1, VDDA\_MCU\_PLLGRP0, VDDA\_MCU\_TEMP, VDDA\_OSC1, VDDA\_PLLGRP0, VDDA\_PLLGRP1, VDDA\_PLLGRP10, VDDA\_PLLGRP12, VDDA\_PLLGRP13, VDDA\_PLLGRP2, VDDA\_PLLGRP5, VDDA\_PLLGRP6, VDDA\_PLLGRP7, VDDA\_PLLGRP8, VDDA\_PLLGRP9, VDDA\_POR\_WKUP, VDDA\_TEMP0, VDDA\_TEMP1, VDDA\_TEMP2, VDDA\_TEMP3, VDDA\_TEMP4, VDDA\_WKUP  
**VDDS\_DDR\_\* includes:** VDDS\_DDR, VDDS\_DDR\_C0, VDDS\_DDR\_C1, VDDS\_DDR\_C2, VDDS\_DDR\_C3  
**VDDSHV\* includes:** VDDSHV0, VDDSHV0\_MCU, VDDSHV1\_MCU, VDDSHV2, VDDSHV2\_MCU, VDDSHV5

## 7.5 Operating Performance Points

This section describes the operating conditions of the device. This section also contains the description of each Operating Performance Point (OPP) for processor clocks and device core clocks.

表 7-1 describes the maximum supported frequency per speed grade for the device.

**表 7-1. Speed Grade Maximum Frequency**

DEVICE	MAXIMUM FREQUENCY (MHz)										
	A72SS0	C71SS0	R5FSS0/1	MCU_ R5SS0	GPU	CBASS0	VPAC	DMPAC	VENCDEC	DMSC	LPDDR4
TDA4xxxT	2000	1000	1000	1000	800	500	720 <sup>(1)</sup>	520 <sup>(1)</sup>	550 (960 or 480MP/s) <sup>(3)</sup>	333	4266 MT/s <sup>(2)</sup>

- (1) Max VPAC and DMPAC speeds not available concurrently due to PLL sharing (max combinations are 720/480 and 650/520 for VPAC/DMPAC, respectively).
- (2) Maximum DDR Frequency will be limited based on the specific memory type (vendor) used in a system and by PCB implementation. TI strongly recommends all designs to follow the TI LPDDR4 EVM PCB layout exactly in every detail (routing, spacing, vias/backdrill, PCB material, etc.) in order to achieve the full specified clock frequency. Refer to the Jacinto 7 DDR Board Design and Layout Guidelines for details.
- (3) Refer to Device Comparison table to determine specific part numbers that include 1x VENCDEC module (480 MP/s) or 2x VENCDEC module (960 MP/s)

## 7.6 Electrical Characteristics

注

The interfaces or signals described in セクション 7.6.1 through セクション 7.6.8 correspond to the interfaces or signals available in multiplexing mode 0 (Primary Function).

All interfaces or signals multiplexed on the balls described in these tables have the same DC electrical characteristics, unless multiplexing involves a PHY and GPIO combination, in which case different DC electrical characteristics are specified for the different multiplexing modes (Functions).

### 7.6.1 I2C, Open-Drain, Fail-Safe (I2C OD FS) Electrical Characteristics

Over recommended operating conditions (unless otherwise noted)

PARAMETER		TEST CONDITIONS	MIN	TYP	MAX	UNIT
<b>1.8-V MODE</b>						
V <sub>IL</sub>	Input low-level threshold				0.3 × VDDSHV <sup>(1)</sup>	V
V <sub>ILSS</sub>	Input low-level threshold steady state				0.3 × VDDSHV <sup>(1)</sup>	V
V <sub>IH</sub>	Input high-level threshold		0.7 × VDDSHV <sup>(1)</sup>			V
V <sub>IHSS</sub>	Input high-level threshold steady state		0.7 × VDDSHV <sup>(1)</sup>			V
V <sub>HYS</sub>	Input Hysteresis Voltage		0.1 × VDDSHV <sup>(1)</sup>			mV
I <sub>IN</sub>	Input Leakage Current	V <sub>I</sub> = 1.8 V or 0 V			±10	μA
V <sub>OL</sub>	Output low-level voltage				0.2 × VDDSHV <sup>(1)</sup>	V
I <sub>OL</sub>	Low Level Output Current	V <sub>OL(MAX)</sub>	6			mA
<b>3.3-V MODE</b>						
V <sub>IL</sub>	Input low-level threshold				0.3 × VDDSHV <sup>(1)</sup>	V
V <sub>ILSS</sub>	Input low-level threshold steady state				0.25 × VDDSHV <sup>(1)</sup>	V
V <sub>IH</sub>	Input high-level threshold		0.7 × VDDSHV <sup>(1)</sup>			V
V <sub>IHSS</sub>	Input high-level threshold steady state		0.7 × VDDSHV <sup>(1)</sup>			V
V <sub>HYS</sub>	Input Hysteresis Voltage		0.05 × VDDSHV <sup>(1)</sup>			mV
I <sub>IN</sub>	Input Leakage Current	V <sub>I</sub> = 3.3 V or 0 V			±10	μA
V <sub>OL</sub>	Output low-level voltage				0.4	V
I <sub>OL</sub>	Low Level Output Current	V <sub>OL(MAX)</sub>	6			mA

(1) VDDSHV stands for corresponding power supply. For more information on the power supply name and the corresponding ball, see the [Pin Attributes](#), POWER column.

### 7.6.2 Fail-Safe Reset (FS Reset) Electrical Characteristics

Over recommended operating conditions (unless otherwise noted)

PARAMETER		TEST CONDITIONS	MIN	TYP	MAX	UNIT
V <sub>IL</sub>	Input low-level threshold				0.3 × VDDSHV <sup>(1)</sup>	V
V <sub>ILSS</sub>	Input low-level threshold steady state				0.3 × VDDSHV <sup>(1)</sup>	V

Over recommended operating conditions (unless otherwise noted)

PARAMETER		TEST CONDITIONS	MIN	TYP	MAX	UNIT
V <sub>IH</sub>	Input high-level threshold		0.7 × VDDSHV <sup>(1)</sup>			V
V <sub>IHSS</sub>	Input high-level threshold steady state		0.7 × VDDSHV <sup>(1)</sup>			V
V <sub>HYS</sub>	Input Hysteresis Voltage		200			mV
I <sub>IN</sub>	Input Leakage Current	V <sub>I</sub> = 1.8 V or 0 V			±10	μA

(1) VDDSHV stands for corresponding power supply. For more information on the power supply name and the corresponding ball, see the *Pin Attributes*, POWER column.

### 7.6.3 HFOSC/LFOSC Electrical Characteristics

Over recommended operating conditions (unless otherwise noted)

PARAMETER		TEST CONDITIONS	MIN	TYP	MAX	UNIT
<b>HIGH FREQUENCY OSCILLATOR</b>						
V <sub>IH</sub>	Input high-level threshold		0.65 × VDDSHV <sup>(1)</sup>			V
V <sub>IL</sub>	Input low-level threshold				0.35 × VDDSHV <sup>(1)</sup>	V
V <sub>HYS</sub>	Input Hysteresis Voltage			49		mV
<b>LOW FREQUENCY OSCILLATOR</b>						
V <sub>IH</sub>	Input high-level threshold		0.65 × VDDA_WKUP <sup>(1)</sup>			V
V <sub>IL</sub>	Input low-level threshold				0.35 × VDDA_WKUP <sup>(1)</sup>	V
V <sub>HYS</sub>	Input Hysteresis Voltage	Active Mode		85		mV
		Bypass Mode		324		mV

(1) VDDSHV stands for corresponding power supply. For WKUP\_OSC0, the corresponding power supply is VDDA\_WKUP. For OSC1\_XI, the corresponding power supply is VDDS\_OSC1.

### 7.6.4 eMMC PHY Electrical Characteristics

Over operating free-air temperature range (unless otherwise noted)

PARAMETER		TEST CONDITIONS	MIN	NOM	MAX	UNIT
V <sub>IL</sub>	Input low-level threshold				0.35 × VDDSHV <sup>(1)</sup>	V
V <sub>ILSS</sub>	Input low-level threshold steady state				0.20	V
V <sub>IH</sub>	Input high-level threshold		0.65 × VDDSHV <sup>(1)</sup>			V
V <sub>IHSS</sub>	Input high-level threshold steady state		1.4			V
I <sub>IN</sub>	Input Leakage Current	V <sub>I</sub> = 1.8 V or 0 V			±10	μA
I <sub>OZ</sub>	Tri-state Output Leakage Current	V <sub>O</sub> = 1.8 V or 0 V			±10	μA
R <sub>PU</sub>	Pull-up Resistor		15	20	25	kΩ
R <sub>PD</sub>	Pull-down Resistor		15	20	25	kΩ
V <sub>OL</sub>	Output low-level voltage				0.30	V
V <sub>OH</sub>	Output high-level voltage		VDDSHV - 0.30 <sup>(1)</sup>			V
I <sub>OL</sub>	Low Level Output Current	V <sub>OL(MAX)</sub>	2			mA
I <sub>OH</sub>	High Level Output Current	V <sub>OH(MAX)</sub>	2			mA

Over operating free-air temperature range (unless otherwise noted)

PARAMETER		TEST CONDITIONS	MIN	NOM	MAX	UNIT
SR <sub>I</sub>	Input Slew Rate		5E +8			V/s

(1) VDDSHV stands for corresponding power supply (vddshv8). For more information on the power supply name and the corresponding ball, see the *Pin Attributes*, POWER column..

### 7.6.5 SDIO Electrical Characteristics

Over operating free-air temperature range (unless otherwise noted)

PARAMETER		TEST CONDITIONS	MIN	NOM	MAX	UNIT
<b>1.8-V MODE</b>						
V <sub>IL</sub>	Input low-level threshold				0.58	V
V <sub>ILSS</sub>	Input low-level threshold steady state				0.58	V
V <sub>IH</sub>	Input high-level threshold		1.27			V
V <sub>IHSS</sub>	Input high-level threshold steady state		1.7			V
V <sub>HYS</sub>	Input Hysteresis Voltage		150			mV
I <sub>IN</sub>	Input Leakage Current	V <sub>I</sub> = 1.8 V or 0 V			±10	µA
R <sub>PU</sub>	Pull-up Resistor		40	50	60	kΩ
R <sub>PD</sub>	Pull-down Resistor		40	50	60	kΩ
V <sub>OL</sub>	Output low-level voltage				0.45	V
V <sub>OH</sub>	Output high-level voltage		VDDSHV-0.45 <sup>(1)</sup>			V
I <sub>OL</sub>	Low Level Output Current	V <sub>OL(MAX)</sub>	4			mA
I <sub>OH</sub>	High Level Output Current	V <sub>OH(MAX)</sub>	4			mA
<b>3.3-V Mode</b>						
V <sub>IL</sub>	Input low-level threshold				0.25 × VDDSHV <sup>(1)</sup>	V
V <sub>ILSS</sub>	Input low-level threshold steady state				0.15 × VDDSHV <sup>(1)</sup>	V
V <sub>IH</sub>	Input high-level threshold		0.625 × VDDSHV <sup>(1)</sup>			V
V <sub>IHSS</sub>	Input high-level threshold steady state		0.625 × VDDSHV <sup>(1)</sup>			V
V <sub>HYS</sub>	Input Hysteresis Voltage		150			mV
I <sub>IN</sub>	Input Leakage Current	V <sub>I</sub> = 1.8 V or 0 V			±10	µA
R <sub>PU</sub>	Pull-up Resistor		40	50	60	kΩ
R <sub>PD</sub>	Pull-down Resistor		40	50	60	kΩ
V <sub>OL</sub>	Output low-level voltage				0.125 × VDDSHV <sup>(1)</sup>	V
V <sub>OH</sub>	Output high-level voltage		0.75 × VDDSHV <sup>(1)</sup>			V
I <sub>OL</sub>	Low Level Output Current	V <sub>OL(MAX)</sub>	6			mA
I <sub>OH</sub>	High Level Output Current	V <sub>OH(MAX)</sub>	10			mA

(1) VDDSHV stands for corresponding power supply (vddshv8). For more information on the power supply name and the corresponding ball, see the *Pin Attributes*, POWER column.

### 7.6.6 CSI2/DSI D-PHY Electrical Characteristics

Over operating free-air temperature range (unless otherwise noted)

PARAMETER		MIN	NOM	MAX	UNIT
<b>Low-Power Receiver (LP-RX)</b>					
V <sub>IH</sub>	Input high-level threshold	740			mV



Over operating free-air temperature range (unless otherwise noted)

PARAMETER		MIN	NOM	MAX	UNIT
V <sub>IL</sub>	Input low-level threshold			550	mV
V <sub>HYS</sub>	Hysteresis	25			mV
<b>Ultra-Low Power Receiver (ULP-RX)</b>					
V <sub>ITH</sub>	Input high-level threshold	740			mV
V <sub>ITL-ULPM</sub>	Input low-level threshold			300	mV
V <sub>HYS</sub>	Hysteresis	25			mV
<b>High Speed Receiver (HS-RX)</b>					
V <sub>IDTH</sub>	Differential input high-level threshold			40	mV
V <sub>IDTL</sub>	Differential input low-level threshold	-40			mV
V <sub>IDMAX</sub>	Maximum differential input voltage			270	mV
V <sub>ILHS</sub>	Single-ended input low-level threshold	-40			mV
V <sub>IHHS</sub>	Single-ended input high-level threshold			460	mV
V <sub>CMRXDC</sub>	Common-mode voltage	70		330	mV

### 7.6.7 ADC12B Electrical Characteristics

Over recommended operating conditions (unless otherwise noted)

PARAMETER		TEST CONDITIONS	MIN	TYP	MAX	UNIT
<b>Analog Input</b>						
V <sub>MCU_ADC0/1_AIN[7:0]</sub>	Full-scale Input Range		VSS	VDDA_ADC0/1		V
DNL	Differential Non-Linearity		-1	0.5	4	LSB
INL	Integral Non-Linearity			±1	±4	LSB
LSB <sub>GAIN-ERROR</sub>	Gain Error			±2		LSB
LSB <sub>OFFSE T-ERROR</sub>	Offset Error			±2		LSB
C <sub>IN</sub>	Input Sampling Capacitance			5.5		pF
SNR	Signal-to-Noise Ratio	Input Signal: 200 kHz sine wave at -0.5 dB Full Scale		70		dB
THD	Total Harmonic Distortion	Input Signal: 200 kHz sine wave at -0.5 dB Full Scale		73		dB
SFDR	Spurious Free Dynamic Range	Input Signal: 200 kHz sine wave at -0.5 dB Full Scale		76		dB
SNR <sub>(PLUS)</sub>	Signal-to-Noise Plus Distortion	Input Signal: 200 kHz sine wave at -0.5 dB Full Scale		69		dB
R <sub>MCU_ADC0/1_AIN[0:7]</sub>	Input Impedance of MCU_ADC0/1_AIN[7:0]	f = input frequency		$[1/((65.97 \times 10^{-12}) \times f_{\text{SMPL\_CLK}})]$		Ω
I <sub>IN</sub>	Input Leakage	MCU_ADC0/1_AIN[7:0] = VSS			-10	μA
		MCU_ADC0/1_AIN[7:0] = VDDA_ADC0/1			24	μA
<b>Sampling Dynamics</b>						
F <sub>SMPL_CLK</sub>	SMPL_CLK Frequency			60		MHz

Over recommended operating conditions (unless otherwise noted)

PARAMETER		TEST CONDITIONS	MIN	TYP	MAX	UNIT
$t_C$	Conversion Time			13		ADC0/1 SMPL_CLK K Cycles
$t_{ACQ}$	Acquisition time		2		257	ADC0/1 SMPL_CLK K Cycles
$T_R$	Sampling Rate	ADC0/1 SMPL_CLK = 60 MHz		4		MSPS
CCISO	Channel to Channel Isolation			100		dB
<b>General Purpose Input Mode<sup>(1)</sup></b>						
$V_{IL}$	Input low-level threshold				$0.35 \times$ VDDA_ADC0/ 1	V
$V_{ILSS}$	Input high-level threshold steady state				$0.35 \times$ VDDA_ADC0/ 1	V
$V_{IH}$	Input high-level threshold		$0.65 \times$ VDDA_ADC0/ 1			V
$V_{IHSS}$	Input high-level threshold steady state		$0.65 \times$ VDDA_ADC0/ 1			V
$V_{HYS}$	Input Hysteresis Voltage		200			mV
$I_{IN}$	Input Leakage Current	$V_I = 1.8\text{ V or }0\text{ V}$			6	$\mu\text{A}$

(1) MCU\_ADC0/1 can be configured to operate in General Purpose Input mode, where all MCU\_ADC0/1\_AIN[7:0] inputs are globally enabled to operate as digital inputs via the ADC0/1\_CTRL register (gpi\_mode\_en = 1).

### 7.6.8 LVCMOS Electrical Characteristics

Over recommended operating conditions (unless otherwise noted)

PARAMETER		TEST CONDITIONS	MIN	TYP	MAX	UNIT
<b>1.8-V MODE</b>						
$V_{IL}$	Input Low Voltage				$0.35 \times VDD^{(1)}$	V
$V_{ILSS}$	Input Low Voltage Steady State				$0.3 \times VDD^{(1)}$	V
$V_{IH}$	Input High Voltage		$0.65 \times VDD^{(1)}$			V
$V_{IHSS}$	Input High Voltage Steady State		$0.85 \times VDD^{(1)}$			V
$V_{HYS}$	Input Hysteresis Voltage		150			mV
$I_{IN}$	Input Leakage Current.	$V_I = 1.8\text{ V or }0\text{ V}$			$\pm 10$	$\mu\text{A}$
$R_{PU}$	Pull-up Resistor		15	22	30	k $\Omega$
$R_{PD}$	Pull-down Resistor		15	22	30	k $\Omega$
$V_{OL}$	Output Low Voltage				0.45	V
$V_{OH}$	Output High Voltage		$VDD^{(1)} - 0.45$			V
$I_{OL}$	Low Level Output Current	$V_{OL(MAX)}$	3			mA
$I_{OH}$	High Level Output Current	$V_{OH(MIN)}$	3			mA
<b>3.3-V MODE</b>						
$V_{IL}$	Input Low Voltage				0.8	V
$V_{ILSS}$	Input Low Voltage Steady State				0.6	V
$V_{IH}$	Input High Voltage		2.0			V
$V_{IHSS}$	Input High Voltage Steady State		2.0			V
$V_{HYS}$	Input Hysteresis Voltage		150			mV
$I_{IN}$	Input Leakage Current.	$V_I = 3.3\text{ V or }0\text{ V}$			$\pm 10$	$\mu\text{A}$

Over recommended operating conditions (unless otherwise noted)

PARAMETER		TEST CONDITIONS	MIN	TYP	MAX	UNIT
R <sub>PU</sub>	Pull-up Resistor		15	22	30	kΩ
R <sub>PD</sub>	Pull-down Resistor		15	22	30	kΩ
V <sub>OL</sub>	Output Low Voltage				0.4	V
V <sub>OH</sub>	Output High Voltage		2.4			V
I <sub>OL</sub>	Low Level Output Current	V <sub>OL(MAX)</sub>	5			mA
I <sub>OH</sub>	High Level Output Current	V <sub>OH(MIN)</sub>	6			mA

(1) VDD stands for corresponding power supply. For more information on the power supply name and the corresponding ball, see the *Pin Attributes*, POWER column.

### 7.6.9 USB2PHY Electrical Characteristics

注

USB0 and USB1 Electrical Characteristics are compliant with Universal Serial Bus Revision 2.0 Specification dated April 27, 2000 including ECNs and Errata as applicable.

### 7.6.10 SerDes 2-L-PHY/4-L-PHY Electrical Characteristics

注

The PCIe interfaces are compliant with the electrical parameters specified in PCI Express® Base Specification Revision 4.0, September 27, 2017.

This Device imposes an additional limit on SERDES REFCLK when used in Input mode with internal termination enabled, as described by parameter V<sub>REFCLK\_TERM</sub> in 表 7-2, 4-L-PHY SERDES REFCLK Electrical Characteristics. Internal termination is enabled by default and must be disabled before applying a reference clock signal that exceeds the limits defined by V<sub>REFCLK\_TERM</sub>. External termination should always be enabled on the source side.

**表 7-2. 4-L-PHY SERDES REFCLK Electrical Characteristics**

Only applies when internal termination is enabled. Over recommended operating conditions (unless otherwise noted)

PARAMETER		MIN	TYP	MAX	UNIT
V <sub>REFCLK_TERM</sub> M	Single ended voltage threshold at the reference clock pin when internal termination is enabled			400	mV
R <sub>TERM</sub>	Internal termination	40	50	62.5	Ω

注

The SerDes USB interfaces are compliant with the USB3.1 SuperSpeed Transmitter and Receiver Normative Electrical Parameters as defined in the Universal Serial Bus 3.1 Specification, Revision 1.0, July 26, 2013.

注

The SGMII interfaces electrical characteristics are compliant with 1000BASE-KX per IEEE802.3 Clause 70.

注

The SGMII 2.5G / XAUI interfaces electrical characteristics are compliant with IEEE802.3 Clause 47.

注

The QSGMII interface electrical characteristics are compliant with QSGMII Specification revision 1.2.

注

The UFS interface electrical characteristics are compliant with MIPI M-PHY Specification v3.1, February 17, 2014.

注

The DP interface electrical characteristics are compliant with the VESA DisplayPort (DP) Standard v 1.4 February 23, 2016.

注

The eDP interface electrical characteristics are compliant with the VESA Embedded DisplayPort (eDP) Standard v1.4b October 23, 2015.

### 7.6.13 DDR0 Electrical Characteristics

注

The DDR interface is compatible with JESD209-4B standard compliant LPDDR4 SDRAM devices.

## 7.7 VPP Specifications for One-Time Programmable (OTP) eFuses

This section specifies the operating conditions required for programming the OTP eFuses and is applicable only for High-Security Devices.

### 7.7.1 Recommended Operating Conditions for OTP eFuse Programming

over operating free-air temperature range (unless otherwise noted)

PARAMETER	DESCRIPTION	MIN	NOM	MAX	UNIT
VDD_CORE	Supply voltage range for the core domain during OTP operation; OPP NOM (BOOT)	See <a href="#">Recommended Operating Conditions</a>			V
VDD_MCU	Supply voltage range for the core domain during OTP operation; OPP NOM (BOOT)	See <a href="#">Recommended Operating Conditions</a>			V
VPP_CORE	Supply voltage range for the eFuse ROM domain during normal operation	N/A <sup>(2)</sup>			
	Supply voltage range for the eFuse ROM domain during OTP programming <sup>(1)</sup>	1.71	1.8	1.89	V
VPP_MCU	Supply voltage range for the eFuse ROM domain during normal operation	N/A <sup>(2)</sup>			
	Supply voltage range for the eFuse ROM domain during OTP programming <sup>(1)</sup>	1.71	1.8	1.89	V

(1) Supply voltage range includes DC errors and peak-to-peak noise. TI power management solutions [TLV70018-Q1](#) from the TLV707x family meet the supply voltage range needed for VPP\_CORE and VPP\_MCU.

(2) N/A stands for Not Applicable.

### 7.7.2 Hardware Requirements

The following hardware requirements must be met when programming keys in the OTP eFuses:

- The VPP\_CORE and VPP\_MCU power supplies must be disabled when not programming OTP registers.
- The VPP\_CORE and VPP\_MCU power supplies must be ramped up after the proper device power-up sequence (for more details, see *Power Supply Sequencing*).

### 7.7.3 Programming Sequence

Programming sequence for OTP eFuses:

- Power on the board per the power-up sequencing. No voltage should be applied on the VPP\_CORE and VPP\_MCU terminals during power up and normal operation.
- Load the OTP write software required to program the eFuse (contact your local TI representative for the OTP software package).
- Apply the voltage on the VPP\_CORE and VPP\_MCU terminals according to the specification in [セクション 7.7.1](#).
- Run the software that programs the OTP registers.
- After validating the content of the OTP registers, remove the voltage from the VPP\_CORE and VPP\_MCU terminals.

### 7.7.4 Impact to Your Hardware Warranty

You recognize and accept at your own risk that your use of eFuse permanently alters the TI device. You acknowledge that eFuse can fail due to incorrect operating conditions or programming sequence. Such a failure may render the TI device inoperable and TI will be unable to confirm the TI device conformed to TI device specifications prior to the attempted eFuse. CONSEQUENTLY, TI WILL HAVE NO LIABILITY FOR ANY TI DEVICES THAT HAVE BEEN eFUSED.

## 7.8 Thermal Resistance Characteristics

This section provides the thermal resistance characteristics used on this device.

For reliability and operability concerns, the maximum junction temperature of the device has to be at or below the  $T_J$  value identified in [Recommended Operating Conditions](#).

### 7.8.1 Thermal Resistance Characteristics for ALY Package

It is recommended to perform thermal simulations at the system level with the worst case device power consumption.

NO.	PARAMETER	DESCRIPTION	ALY PACKAGE	
			$^{\circ}\text{C}/\text{W}^{(1) (3)}$	AIR FLOW (m/s) <sup>(2)</sup>
T1	$R_{\theta_{JC}}$	Junction-to-case	0.11	N/A
T2	$R_{\theta_{JB}}$	Junction-to-board	1.6	N/A
T3	$R_{\theta_{JA}}$	Junction-to-free air	8.3	0
T4		Junction-to-moving air	4.7	1
T5			3.9	2
T7	$\Psi_{JT}$	Junction-to-package top	0.1	0
T8			0.1	1
T9			0.1	2
T11	$\Psi_{JB}$	Junction-to-board	1.3	0
T12			1.1	1
T13			1.0	2

(1) These values are based on a JEDEC defined 2S2P system (with the exception of the Theta JC [ $R_{\theta_{JC}}$ ] value, which is based on a JEDEC defined 1S0P system) and will change based on environment as well as application. For more information, see these EIA/ JEDEC standards:

- JESD51-2, *Integrated Circuits Thermal Test Method Environment Conditions - Natural Convection (Still Air)*
- JESD51-3, *Low Effective Thermal Conductivity Test Board for Leaded Surface Mount Packages*
- JESD51-6, *Integrated Circuit Thermal Test Method Environmental Conditions - Forced Convection (Moving Air)*
- JESD51-7, *High Effective Thermal Conductivity Test Board for Leaded Surface Mount Packages*
- JESD51-9, *Test Boards for Area Array Surface Mount Packages*

(2) m/s = meters per second.

(3)  $^{\circ}\text{C}/\text{W}$  = degrees Celsius per watt.

## 7.9 Temperature Sensor Characteristics

This section summarizes the Voltage and Temperature Module (VTM) on die temperature sensor characteristics. For reliability and operability concerns, the maximum junction temperature of the device has to be at or below the  $T_J$  value identified in the [Recommended Operating Conditions](#).

**表 7-3. VTM Die Temperature sensor Characteristics**

PARAMETER		TEST CONDITIONS	MIN	TYP	MAX	UNIT
T <sub>acc</sub>	VTM temperature sensor accuracy	-40 to 110 °C	-5		5	°C
		110 to 125 °C	-2		2	°C

## 7.10 Timing and Switching Characteristics

注

The timings presented in this section are valid when the DRV\_STR (Drive Strength) control in the associated PADCONFIG registers are set to the default “0h – Nominal (recommended)” value.

### 7.10.1 Timing Parameters and Information

The timing parameter symbols used in [Timing and Switching Characteristics](#) are created in accordance with JEDEC Standard 100. To shorten the symbols, some pin names and other related terminologies have been abbreviated in [表 7-4](#):

**表 7-4. Timing Parameters Subscripts**

SYMBOL	PARAMETER
c	Cycle time (period)
d	Delay time
dis	Disable time
en	Enable time
h	Hold time
su	Setup time
START	Start bit
t	Transition time
v	Valid time
w	Pulse duration (width)
X	Unknown, changing, or don't care level
F	Fall time
H	High
L	Low
R	Rise time
V	Valid
IV	Invalid
AE	Active Edge
FE	First Edge
LE	Last Edge
Z	High impedance



## 7.10.2 Power Supply Sequencing

This section describes power supply sequencing required to ensure proper device operation. The device can be operated using either an isolated or combined MCU & Main power distribution network (PDN). Two different primary power sequences are recommended based upon isolated and combined MCU & Main PDNs. In addition, the device can be operated in either MCU Only or DDR Retention or GPIO Retention low power modes. Two different desired device power supply sequences for entry and exit of low power modes are shown.

The power supply names used in this section are specific to this device and align to names given in the Signal Descriptions section. Common power supply names may be used across different devices within the Jacinto 7™ processor family. These common supply names will have very similar if not identical functions across devices.

All power sequencing timing diagrams shown will use the following terminology:

- Primary = Essential power sequences of all voltage domains between off and full active states.
- $V_{OPR\ MIN}$  = Minimum operational voltage level that ensures functionality as specified in Recommended Operating Conditions
- Ramp-up = start of a voltage supply transition time from off condition to  $V_{opr\ min}$ .
- Ramp-down = start of a voltage supply transition time from  $V_{opr}$  to off condition
- Supply\_“n” = multiple instances of similar power supplies (i.e.  $VDDSHV_n = VDDSHV_0, VDDSHV_1, VDDSHV_2 \dots VDDSHV_6$ )
- Supply\_“xxx” = multiple instances of similar power supplies used for different signal types (i.e.  $VDDA_{1P8\_xxx} = VDDA_{1P8\_DSITX}, VDDA_{1P8\_USB}, VDDA_{0P8\_DSITX}, VDDA_{0P8\_USB}$ , etc.)
- Time stamps = “T#” markers with descriptions and approximate elapsed times for general reference. Specific timing transitions are dependent upon PDN design (see PDN User Guide for details).

### 7.10.2.1 Power Supply Slew Rate Requirement

To maintain the safe operating range of the internal ESD protection devices, TI recommends limiting the maximum slew rate of supplies to be less than 100 mV/us, as shown in [Figure 7-2](#). For instance, a 1.8V supply should have a ramp time  $> 18 \mu s$  to ensure the slew rate  $< 100 mV/us$ .

[Figure 7-2](#) describes the Power Supply Slew Rate Requirement in the device.

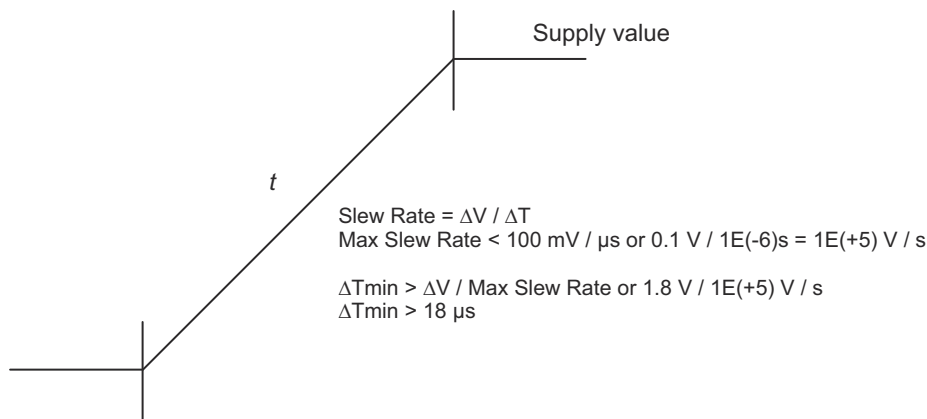

**Figure 7-2. Power Supply Slew and Slew Rate**

### 7.10.2.2 Combined MCU and Main Domains Power- Up Sequencing

セクション 7.10.2.2 describes the primary power-up sequencing when similar MCU and Main voltage domains are combined into common power rails. Combining MCU and Main voltage domains simplifies PDN design by reducing total number of power rails and sources while making MCU and Main processor sub-systems operational dependent on common power rails.

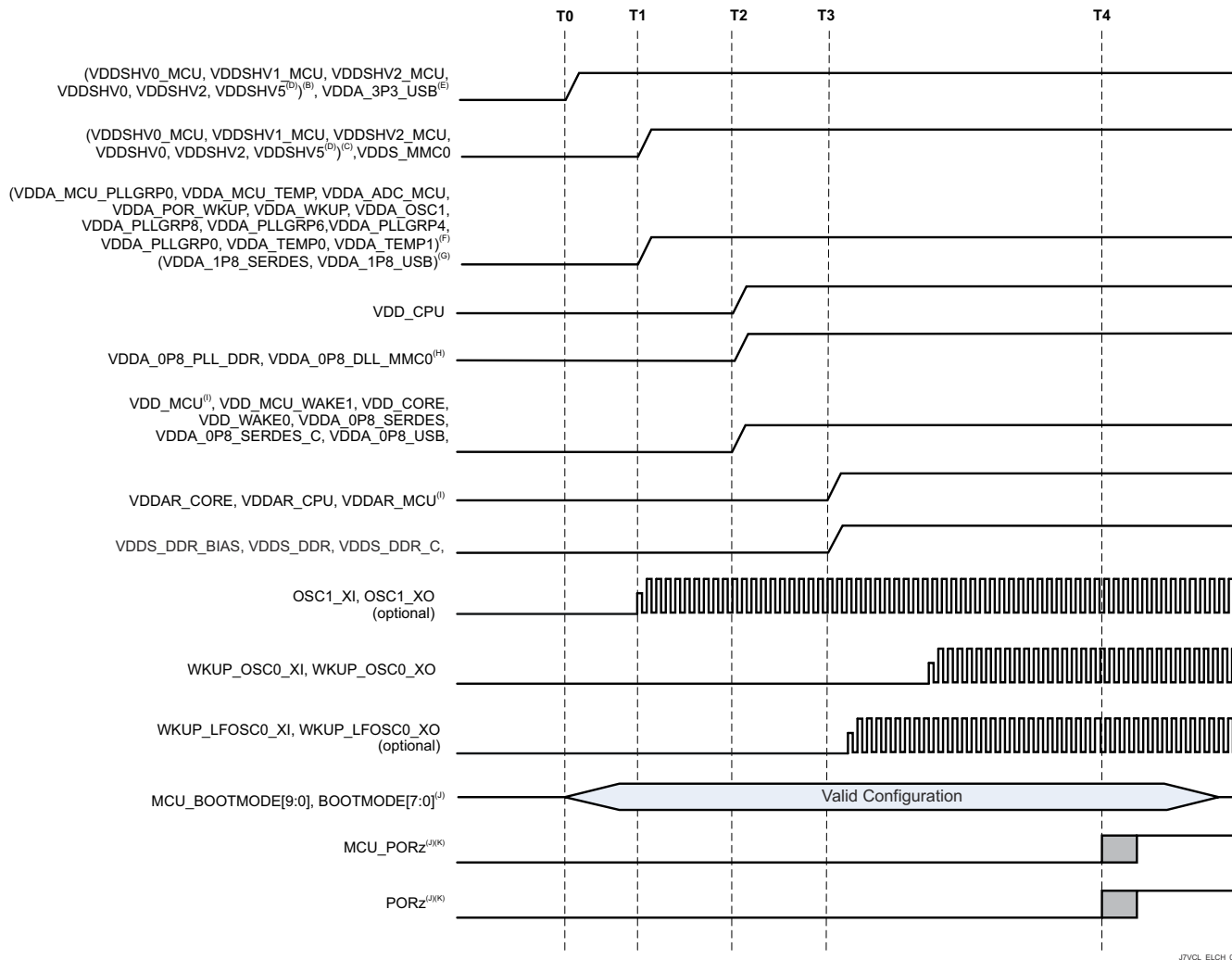

J7VCL\_ELCH\_01

- A. Time stamp markers:
- T0 – 3.3V voltages start ramp-up to  $V_{OPR\ MIN}$ . (0 ms)
  - T1 – 1.8-V voltages start ramp-up to  $V_{OPR\ MIN}$ . (2 ms)
  - T2 – Low voltage core supplies start ramp-up to  $V_{OPR\ MIN}$ . (3 ms)
  - T3 – Low voltage RAM array voltages start ramp-up to  $V_{OPR\ MIN}$ . (4 ms)
  - T4 – OSC1 is stable and PORz/MCU\_PORz are de-asserted to release processor from reset. (13 ms)
- B. Any MCU or Main dual voltage IO supplies (VDDSHVn\_MCU or VDDSHVn) being supplied by 3.3V to support 3.3V digital interfaces. A few supplies could have varying start times between T0 to T1 due to PDN designs using different power resources with varying turn-on & ramp-up time delays.
- C. Any MCU or Main dual voltage IO supplies (VDDSHVn\_MCU or VDDSHVn) being supplied by 1.8 V to support 1.8-V digital interfaces. When eMMC memories are used, Main 1.8-V supplies could have a ramp-up aligned to T3 due to PDN designs grouping supplies with VDD\_MMC0.
- D. VDDSHV5 supports MMC1 signaling for SD memory cards. If compliant high-speed SD card operation is needed, then an independent, dual voltage (3.3 V/1.8 V) power source and rail are required. The start of ramp-up to 3.3 V will be same as other 3.3-V domains as

- shown. If SD card is not needed or standard data rates with fixed 3.3 V operation is acceptable, then domain can be grouped with digital IO 3.3-V power rail. If a SD card is capable of operating with fixed 1.8 V, then domain can be grouped with digital IO 1.8-V power rail.
- E. VDDA\_3P3\_USB is 3.3-V analog domain used for USB 2.0 differential interface signaling. A low noise, analog supply is recommended to provide best signal integrity for USB data eye mask compliance. The start of ramp-up to 3.3 V will be same as other 3.3-V domains as shown. If USB interface is not needed or data bit errors can be tolerated, then domain can be grouped with 3.3-V digital IO power rail either directly or through a supply filter.
  - F. VDDA\_1P8\_<clk/pll/ana> are 1.8-V analog domains supporting clock oscillator, PLL and analog circuitry needing a low noise supply for optimal performance. It is not recommended to combine digital VDDSHVn\_MCU and VDDSHVn IO domains since high frequency switching noise could negatively impact jitter performance of clock, PLL and DLL signals. Combining analog VDDA\_1p8\_<phy> domains should be avoided but if grouped, then in-line ferrite bead supply filtering is required.
  - G. VDDA\_1P8\_<phy> are 1.8-V analog domains supporting multiple serial PHY interfaces. A low noise, analog supply is recommended to provide best signal integrity, interface performance and spec compliance. If any of these interfaces are not needed, data bit errors or non-compliant operation can be tolerated, then domains can be grouped with digital IO 1.8-V power rail either directly or through an in-line supply filter is allowed.
  - H. VDDA\_0P8\_<dll/pll> are 0.8-V analog domains supporting PLL and DLL circuitry needing a low noise supply for optimal performance. It is not recommended to combine these domains with any other 0.8-V domains since high frequency switching noise could negatively impact jitter performance of PLL and DLL signals.
  - I. VDD\_MCU is a digital voltage domain with a wide range enabling it to be grouped and ramped-up with either 0.8-V VDD\_CORE or 0.85-V RAM array (VDDAR\_xxx) domains.
  - J. Minimum set-up and hold times shown with respect to MCU\_PORz and PORz asserting high to latch MCU\_BOOTMODEn (referenced to MCU\_VDDSHV0) and BOOTMODEn (reference to VDDSHV2) settings into registers during power up sequence.
  - K. Minimum elapsed time from crystal oscillator circuitry being energized (VDDA\_OSC1 at T1) until stable clock frequency is reached depends upon on crystal oscillator, capacitor parameters and PCB parasitic values. A conservative 10 ms elapsed time defined by (T4 – T1) time stamps is shown. This could be reduced depending upon customer's clock circuit (that is, crystal oscillator or clock generator) and PCB designs.

### 7-3. Combined MCU and Main Domains, Primary Power-Up Sequence

### 7.10.2.3 Combined MCU and Main Domains Power- Down Sequencing

☒ 7-4 describes the device power-down sequencing.

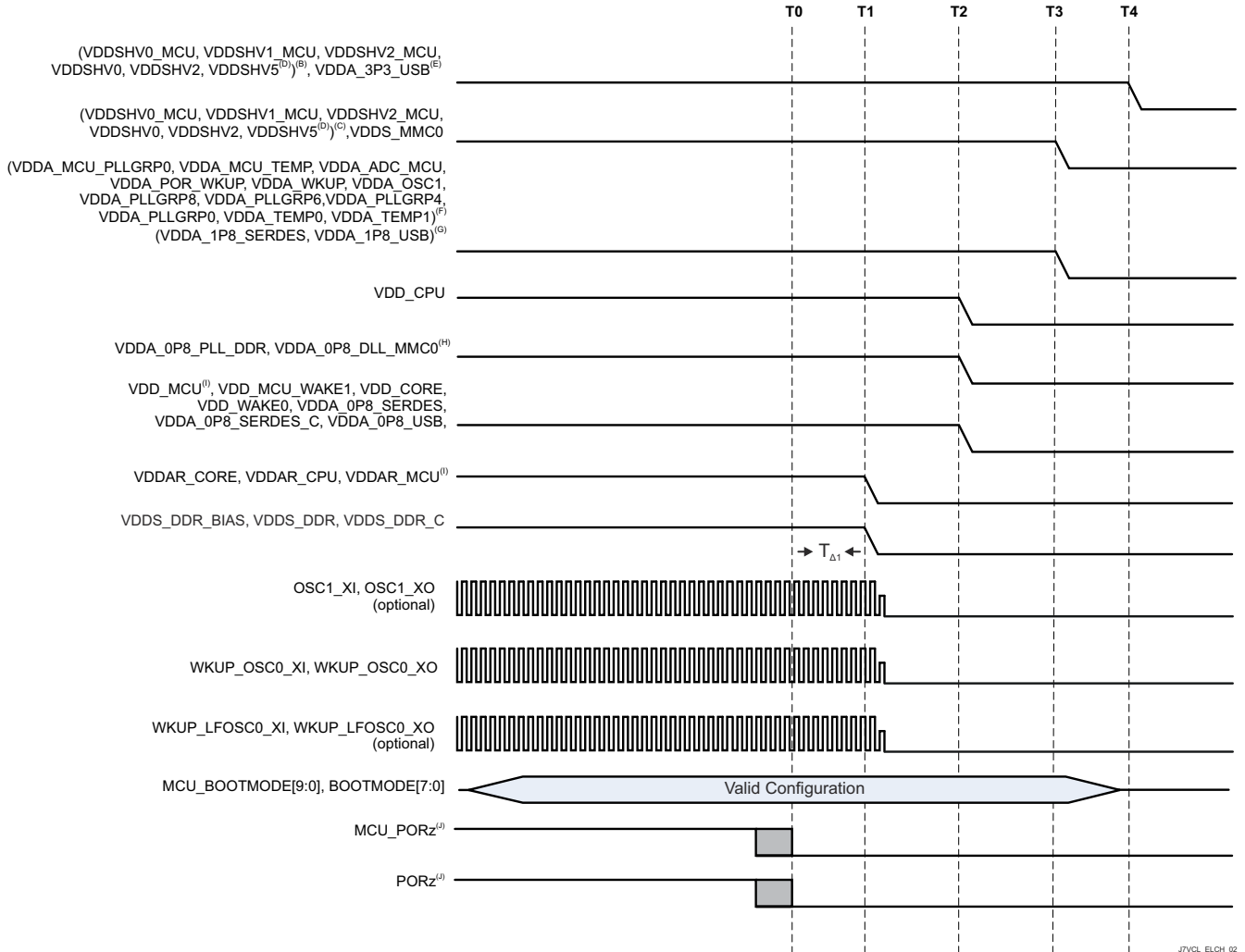

- A. Time stamp markers:
- T0 – MCU\_PORz & PORz assert low to put all processor resources in safe state. (0 ms)
  - T1 – Main DDR, SRAM Core, and SRAM CPU power supplies start ramp-down. (0.5 ms)
  - T2 – Low voltage core supplies start supply ramp-down. (2.5 ms)
  - T3 - 1.8-V voltages start supply ramp-down. (3.0 ms)
  - T4 – 3.3V voltages start supply ramp-down. (3.5 ms)
- B. Any MCU or Main dual voltage IO domains (VDDSHVn\_MCU or VDDSHVn) being supplied by 3.3 V to support 3.3-V digital interfaces.
- C. Any MCU or Main dual voltage IO domains (VDDSHVn\_MCU or VDDSHVn) being supplied by 1.8 V to support 1.8-V digital interfaces.
- D. VDDSHV5 supports MMC1 signaling for SD memory cards. A dual voltage (3.3 V/1.8 V) power rail is required for compliant, high-speed SD card operations. If SD card is not needed or standard data rates with fixed 3.3-V operation is acceptable, then domain can be grouped with digital IO 3.3-V power rail. If a SD card is capable of operating with fixed 1.8 V, then domain can be grouped with digital IO 1.8-V power rail.
- E. VDDA\_3P3\_USB is 3.3-V analog domain used for USB 2.0 differential interface signaling. A low noise, analog supply is recommended to provide best signal integrity for USB data eye mask compliance. If USB interface is not needed or data bit errors can be tolerated, then domain can be grouped with 3.3-V digital IO power rail either directly or through a supply filter.
- F. VDDA\_1P8\_<clk/pll/ana> are 1.8V analog domains supporting clock oscillator, PLL and analog circuitry needing a low noise supply for optimal performance. It is not recommended to combine digital VDDSHVn\_MCU and VDDSHVn IO domains since high frequency

ADVANCE INFORMATION

switching noise could negatively impact jitter performance of clock, PLL and DLL signals. Combining analog VDDA\_1p8\_<phy> domains should be avoided but if grouped, then in-line ferrite bead supply filtering is required .

- G. VDDA\_1P8\_<phy> are 1.8-V analog domains supporting multiple serial PHY interfaces. A low noise, analog supply is recommended to provide best signal integrity, interface performance and spec compliance. If any of these interfaces are not needed, data bit errors or non-compliant operation can be tolerated, then domains can be grouped with digital IO 1.8-V power rail either directly or through an in-line supply filter is allowed.
- H. VDDA\_0P8\_<dll/pll> are 0.8-V analog domains supporting PLL and DLL circuitry needing a low noise supply for optimal performance. It is not recommended to combine these domains with any other 0.8-V domains since high frequency switching noise could negatively impact jitter performance of PLL and DLL signals.
- I. VDD\_MCU is a digital voltage domain with a wide range enabling it to be grouped and ramped-up with either 0.8-V VDD\_CORE or 0.85-V RAM array (VDDAR\_xxx) domains.
- J. MCU\_PORz and PORz must be asserted low for  $T_{\Delta 1} = 200 \mu s$  MIN to ensure SoC resources enter into safe state before any voltage begins to ramp down.

#### **7-4. Combined MCU and Main Domains, Primary Power-Down Sequence**

#### 7.10.2.4 Isolated MCU and Main Domains Power- Up Sequencing

Isolated MCU and Main voltage domains enable an SoC's MCU and Main processor sub-systems to operate independently. There are 2 reasons an SoC's PDN design may need to support independent MCU and Main processor functionality. First is to provide flexibility to enable SoC low power modes that can significantly reduce SoC power dissipation when processor operations are not needed. Second is to enable robustness to gain freedom from interference (FFI) of a single fault impacting both MCU and Main processor sub-systems which is especially beneficial if using the SoC's MCU as the system safety monitoring processor. The number of additional PDN power rails needed is dependent upon number of different MCU IO signaling voltage levels. If only 1.8V IO signaling is used, then only 2 additional power rails could be required. If both 1.8 and 3.3V IO signaling is desired, then 4 additional power rails could be needed.

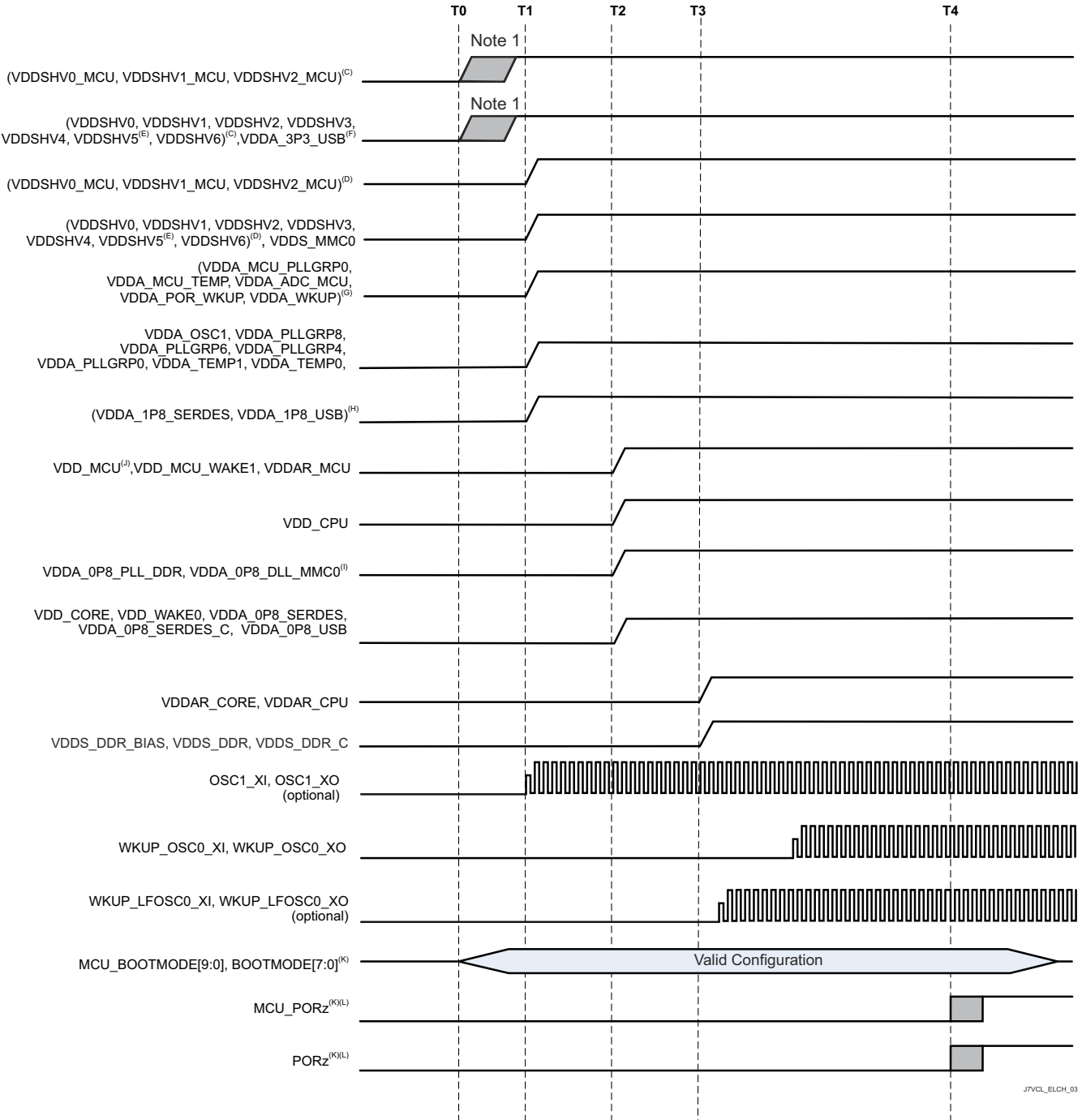

- A. T1 Time stamp markers:
- T0 – All 3.3-V voltages start supply ramp-up to  $V_{OPR\ MIN}$ . (0 ms)
  - T1 – All 1.8-V voltages start supply ramp-up to  $V_{OPR\ MIN}$ . (2 ms)
  - T2 – All core voltages start supply ramp-up to  $V_{OPR\ MIN}$ . (3 ms)
  - T3 – All RAM array voltages start supply ramp-up to  $V_{OPR\ MIN}$ . (4 ms)
  - T4 – OSC1 is stable and PORz/MCU\_PORz are de-asserted to release processor from reset. (13 ms)
- B. Any MCU or Main dual voltage IO supplies (VDDSHVn\_MCU or VDDSHVn) being supplied by 3.3 V to support 3.3-V digital interfaces. A few supplies could have varying start times between T0 to T1 due to PDN designs using different power resources with varying turn-on & ramp-up time delays.

- C. Any MCU or Main dual voltage IO supplies (VDDSHVn\_MCU or VDDSHVn) being supplied by 1.8 V to support 1.8-V digital interfaces. When eMMC memories are used, Main 1.8-V supplies could have delayed start times that aligns to T3 due to PDN designs grouping supplies with VDD\_MMC0.
- D. VDDSHV5 supports MMC1 signaling for SD memory cards. If compliant UHS-I SD card operation is needed, then an independent, dual voltage (3.3 V/1.8 V) power source and rail are required. The start of ramp-up to 3.3 V will be same as other 3.3-V domains as shown. If SD card is not needed or standard data rates with fixed 3.3-V operation is acceptable, then supply can be grouped with digital IO 3.3-V power rail. If a SD card is capable of operating with fixed 1.8 V, then supply can be grouped with digital IO 1.8-V power rail.
- E. VDDA\_3P3\_USB is 3.3-V analog supply used for USB 2.0 differential interface signaling. A low noise, analog supply is recommended to provide best signal integrity for USB data eye mask compliance. The start of ramp-up to 3.3 V will be same as other 3.3-V domains as shown. If USB interface is not needed or data bit errors can be tolerated, then supply can be grouped with 3.3-V digital IO power rail either directly or through a supply filter.
- F. VDDA\_1P8\_<clk/pll/ana> are 1.8-V analog domains supporting clock oscillator, PLL and analog circuitry needing a low noise supply for optimal performance. It is not recommended to combine digital VDDSHVn\_MCU and VDDSHVn IO domains since high frequency switching noise could negatively impact jitter performance of clock, PLL and DLL signals. Combining analog VDDA\_1p8\_<phy> domains should be avoided but if grouped, then in-line ferrite bead supply filtering is required.
- G. VDDA\_1P8\_<phy> are 1.8-V analog domains supporting multiple serial PHY interfaces. A low noise, analog supply is recommended to provide best signal integrity, interface performance and spec compliance. If any of these interfaces are not needed, data bit errors or non-compliant operation can be tolerated, then domains can be grouped with digital IO 1.8-V power rail either directly or through an in-line supply filter is allowed.
- H. VDDA\_0P8\_<dll/pll> are 0.8-V analog domains supporting PLL and DLL circuitry needing a low noise supply for optimal performance. It is not recommended to combine these domains with any other 0.8-V domains since high frequency switching noise could negatively impact jitter performance of PLL and DLL signals.
- I. VDD\_MCU is a digital voltage supply with a wide operational voltage range and power sequencing flexibility, enabling it to be grouped and ramped-up with either 0.8-V VDD\_CORE at time stamp T2 or 0.85-V RAM array domains (VDDAR\_XXX) at time stamp T3.
- J. Minimum set-up and hold times shown with respect to MCU\_PORz and PORz asserting high to latch MCU\_BOOTMODEn (referenced to MCU\_VDDSHV0) and BOOTMODEn (reference to VDDSHV2) settings into registers during power up sequence.
- K. Minimum elapsed time from crystal oscillator circuitry being energized (VDDA\_OSC1 at T1) until stable clock frequency is reached depends upon on crystal oscillator, capacitor parameters and PCB parasitic values. A conservative 10 ms elapsed time defined by (T4 – T1) time stamps is shown. This could be reduced depending upon customer's clock circuit (that is, crystal oscillator or clock generator) and PCB designs.

### 7-5. Isolated MCU and Main Domains, Primary Power-Up Sequence



### 7.10.2.5 Isolated MCU and Main Domains Power- Down Sequencing

7-6 describes the device power-down sequencing.

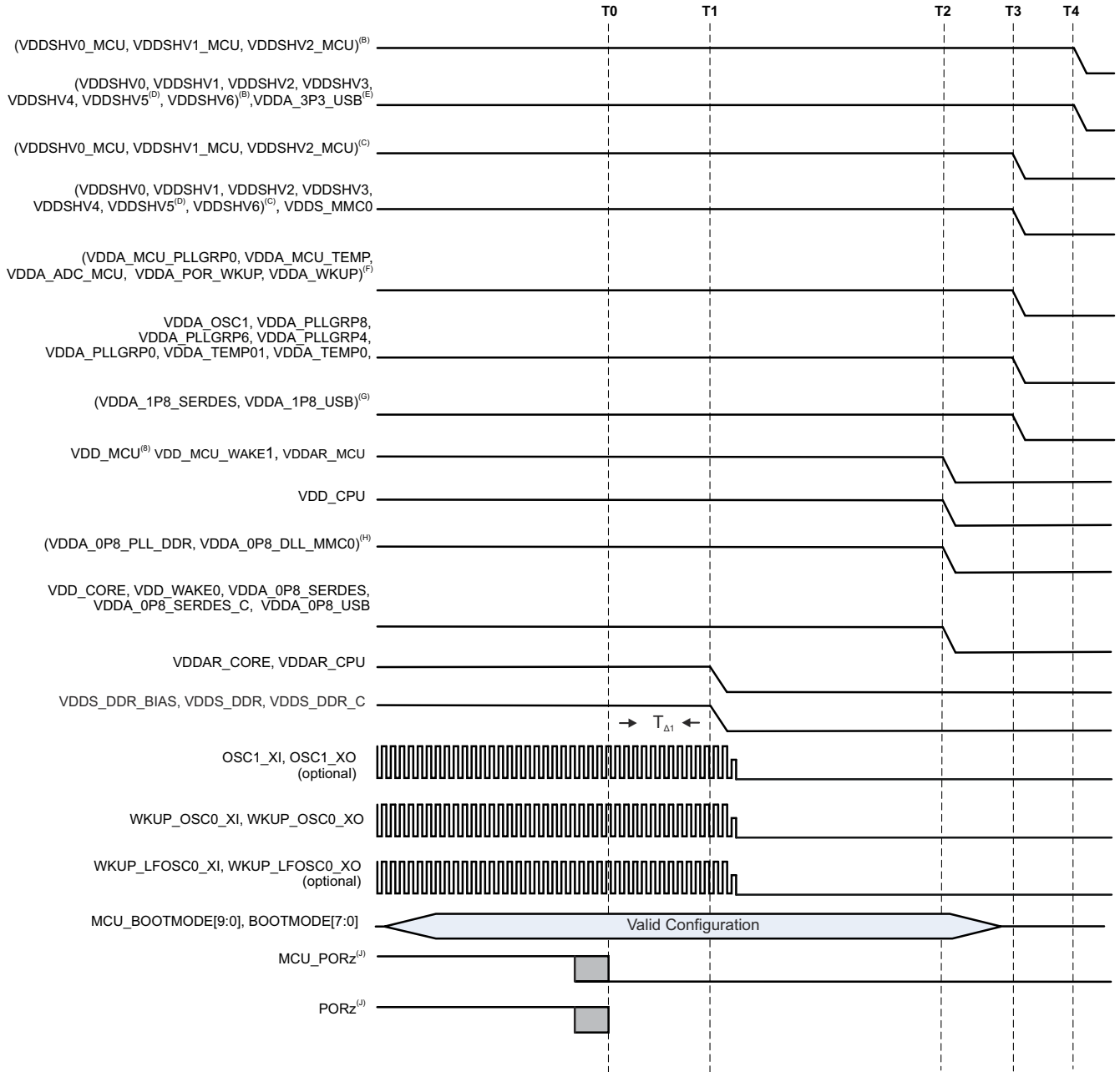

J7VCL\_ELCH\_04

- A. Time stamp markers:
- T0 – MCU\_PORz and PORz assert low to put all processor resources in safe state. (0 ms)
  - T1 – Main DDR, SRAM Core, and SRAM CPU power domains start ramp-down. (0.5 ms)
  - T2 – All core voltages start supply ramp-down. (2.5 ms)
  - T3 – All 1.8V voltages start supply ramp-down. (3.0 ms)
  - T4 – All 3.3V voltages start supply ramp-down. (3.5 ms)
- B. Any MCU or Main dual voltage IO domains (VDDSHVn\_MCU or VDDSHVn) being supplied by 3.3 V to support 3.3-V digital interfaces.
- C. Any MCU or Main dual voltage IO supplies (VDDSHVn\_MCU or VDDSHVn) being supplied by 1.8 V to support 1.8-V digital interfaces. When eMMC memories are used, Main 1.8-V supplies could have a ramp-down aligned to T1 due to PDN designs grouping supplies with VDD\_MMC0.

- D. VDDSHV5 supports MMC1 signaling for SD memory cards. A dual voltage (3.3 V/1.8 V) power rail is required for compliant, high-speed SD card operations. If compliant high-speed SD card operation is needed, then an independent, dual voltage (3.3 V/1.8 V) power source and rail are required. The start of ramp-down from 3.3 V/1.8 V will be same as other 3.3-V domains as shown. If SD card is not needed or standard data rates with fixed 3.3-V operation is acceptable, then domain can be grouped with digital IO 3.3-V power rail. If a SD card is capable of operating with fixed 1.8 V, then domain can be grouped with digital IO 1.8-V power rail.
- E. VDDA\_3P3\_USB is 3.3-V analog domain used for USB 2.0 differential interface signaling. A low noise, analog supply is recommended to provide best signal integrity for USB data eye mask compliance. The start of ramp-down from 3.3 V will be same as other 3.3-V domains as shown. If USB interface is not needed or data bit errors can be tolerated, then domain can be grouped with 3.3-V digital IO power rail either directly or through a supply filter.
- F. VDDA\_1P8\_<clk/pll/ana> are 1.8-V analog domains supporting clock oscillator, PLL and analog circuitry needing a low noise supply for optimal performance. It is not recommended to combine digital VDDSHVn\_MCU and VDDSHVn IO domains since high frequency switching noise could negatively impact jitter performance of clock, PLL and DLL signals. Combining analog VDDA\_1p8\_<phy> domains should be avoided but if grouped, then in-line ferrite bead supply filtering is required.
- G. VDDA\_1P8\_<phy> are 1.8-V analog domains supporting multiple serial PHY interfaces. A low noise, analog supply is recommended to provide best signal integrity, interface performance and spec compliance. If any of these interfaces are not needed, data bit errors or non-compliant operation can be tolerated, then domains can be grouped with digital IO 1.8-V power rail either directly or through an in-line supply filter is allowed.
- H. VDDA\_0P8\_<dll/pll> are 0.8-V analog domains supporting PLL and DLL circuitry needing a low noise supply for optimal performance. It is not recommended to combine these domains with any other 0.8-V domains since high frequency switching noise could negatively impact jitter performance of PLL and DLL signals.
- I. VDD\_MCU is a digital voltage domain with a wide range enabling it to be grouped and ramped-up with either 0.8-V VDD\_CORE or 0.85V RAM array (VDDAR\_xxx) domains.
- J. MCU\_PORz and PORz must be asserted low for  $T_{\Delta 1} = 200 \mu s$  MIN to ensure SoC resources enter into safe state before any voltage begins to ramp down.

## 7-6. Isolated MCU and Main Domains, Primary Power- Down Sequencing

### 7.10.2.6 Independent MCU and Main Domains, Entry and Exit of MCU Only Sequencing

Entry into MCU Only state is accomplished by executing a power down sequence except for the 4 MCU domains that remain energized. Exit from MCU Only state is accomplished by executing a power up sequence with the 4 MCU domains remaining energized throughout the sequ.

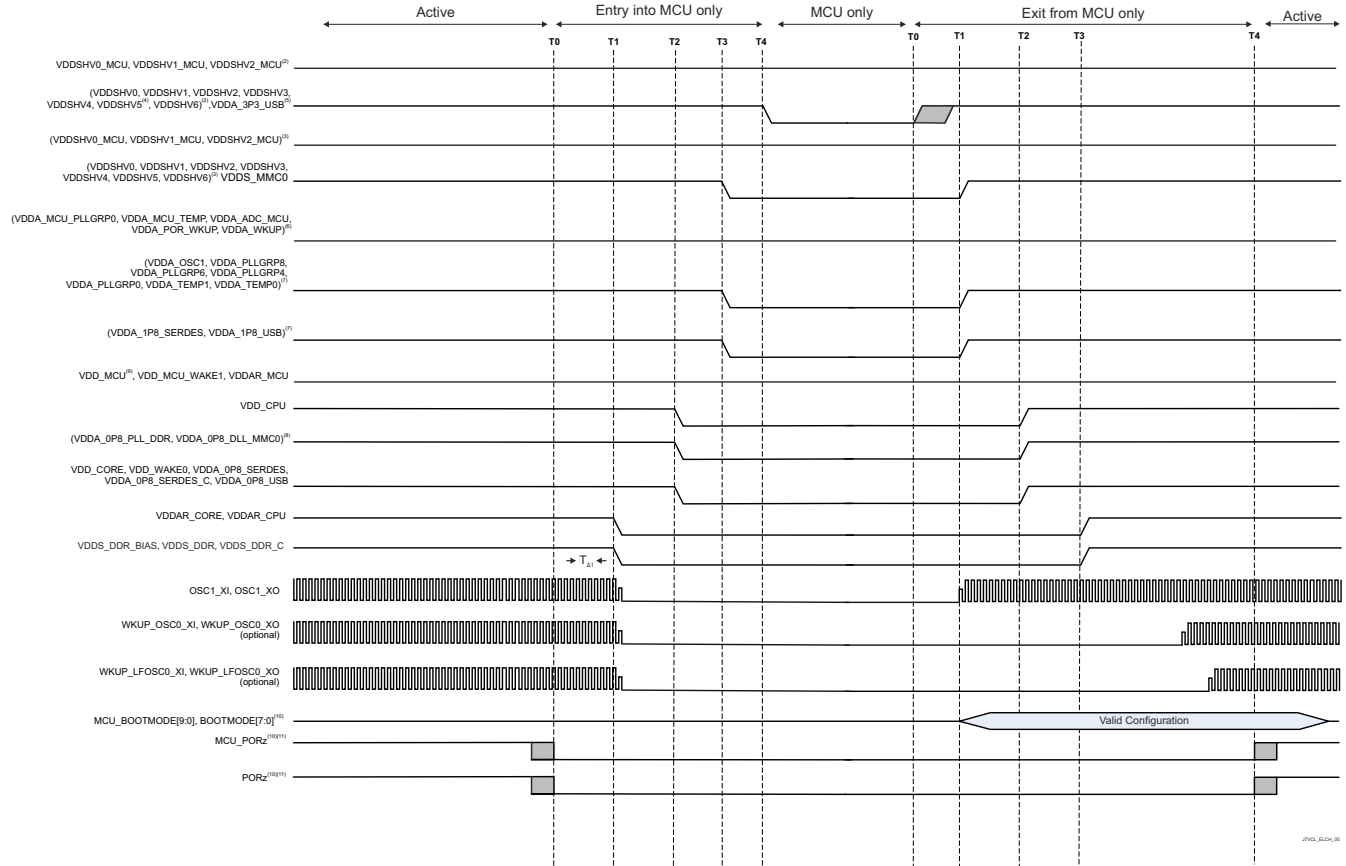

**7-7. Independent MCU and Main Domains, Entry and Exit of MCU Only Sequencing**

**7.10.2.7 Independent MCU and Main Domains, Entry and Exit of DDR Retention State**

Entry into DDR Retention state is accomplished by executing a power down sequence except for the 4 DDR domains that remain energized. Exit from DDR Retention state is accomplished by executing a power up sequence with the 3 DDR domains remaining energized throughout the sequence.

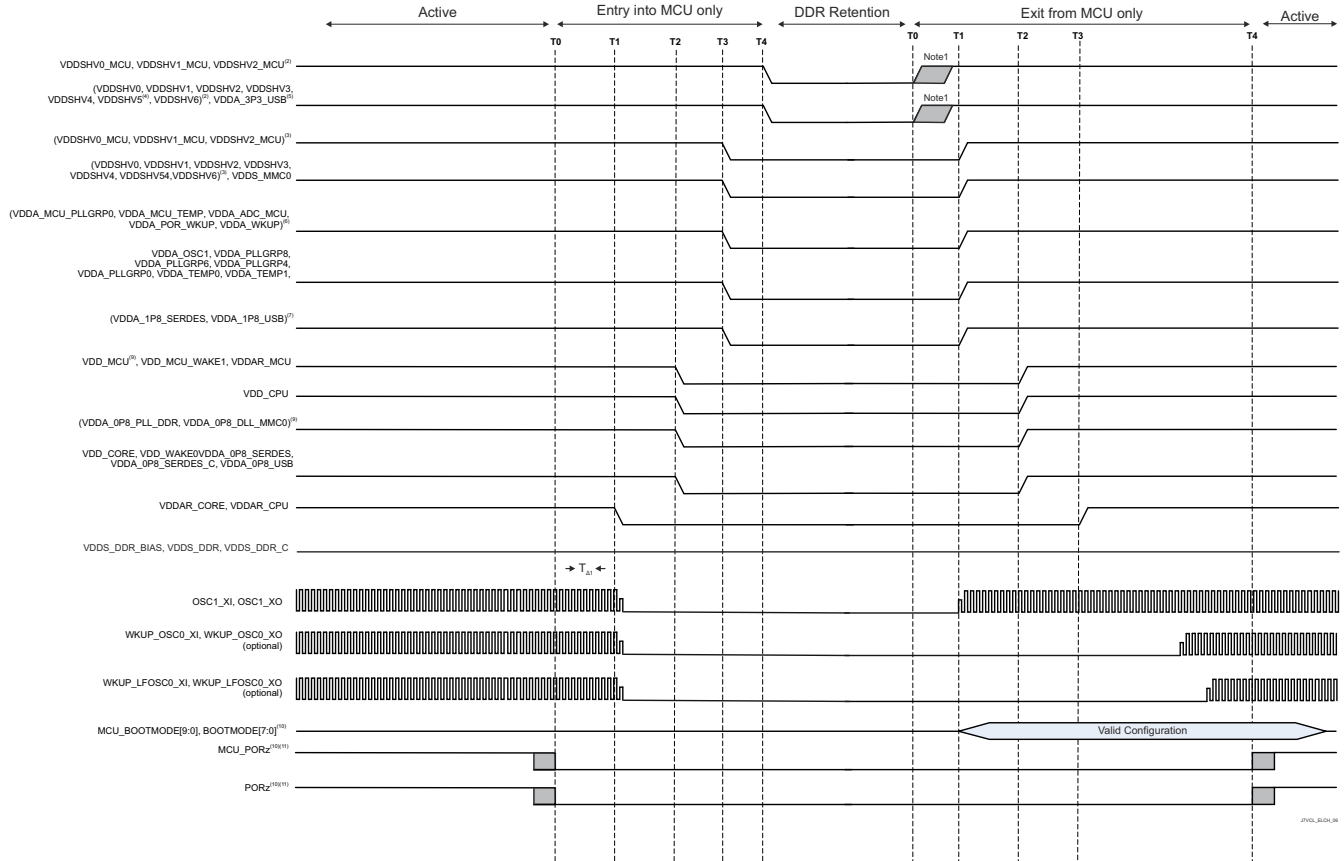

7-8. Independent MCU and Main Domains, Entry and Exit of DDR Retention State

### 7.10.2.8 Independent MCU and Main Domains, Entry and Exit of GPIO Retention Sequencing

Entry into GPIO Retention state is accomplished by executing a power down sequence except for the 2 or 4 wake domains that remain energized. Exit from GPIO Retention state is accomplished by executing a power up sequence with the 2 or 4 wake DDR domains remaining energized throughout the sequence.

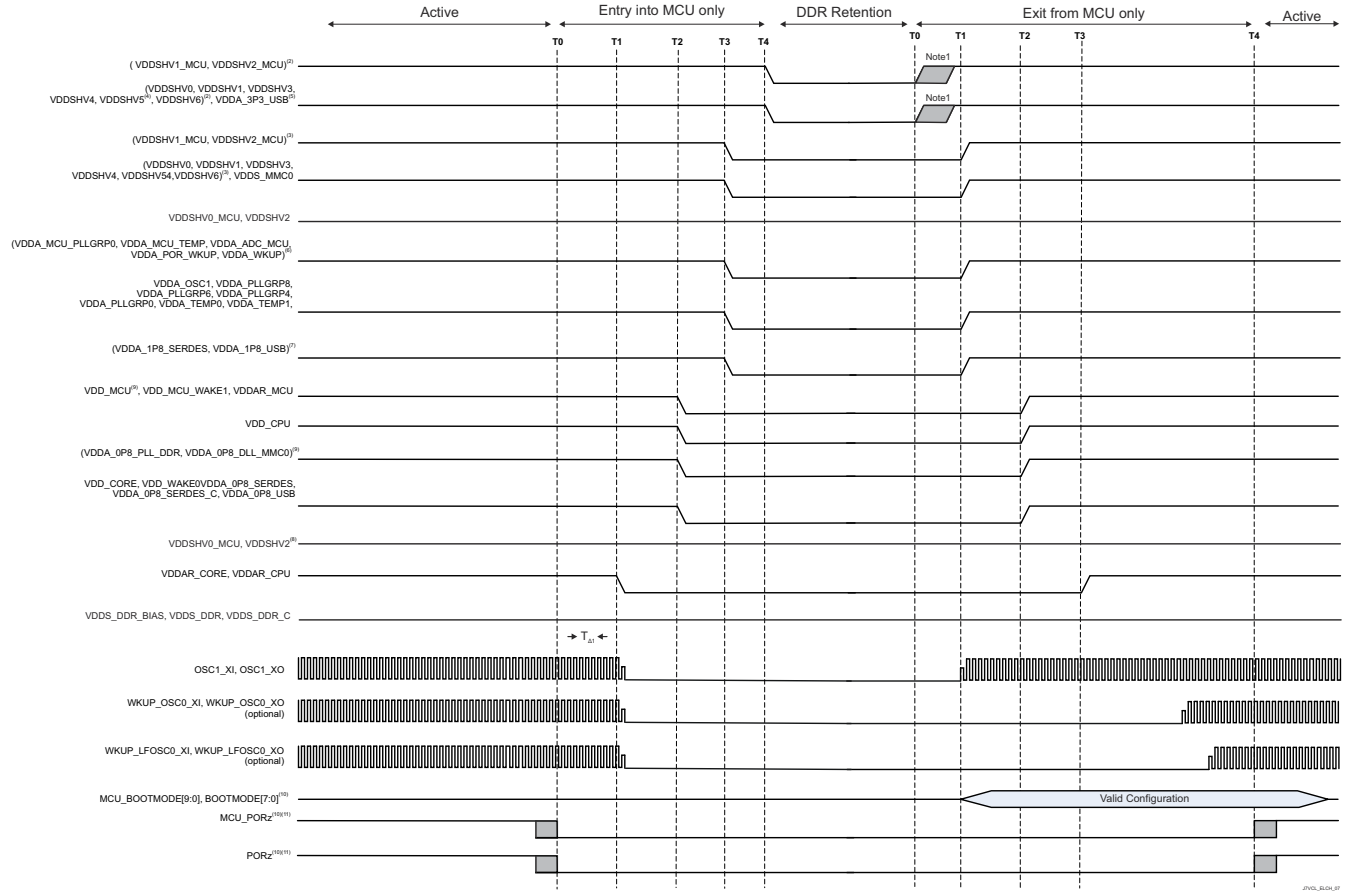

 **7-9. Independent MCU and Main Domains, Entry and Exit of GPIO Retention Sequencing**

### 7.10.3 System Timing

For more details about features and additional description information on the subsystem multiplexing signals, see the corresponding sections within [Signal Descriptions](#) and *Detailed Description*.

**表 7-5. System Timing Conditions**

PARAMETER		MIN	MAX	UNIT
<b>INPUT CONDITIONS</b>				
SR <sub>I</sub>	Input slew rate	0.5	2	V/ns
<b>OUTPUT CONDITIONS</b>				
C <sub>L</sub>	Output load capacitance	3	30	pF

#### 7.10.3.1 Reset Timing

The tables and figures provided in this section define the timing requirements and switching characteristics for reset related signals.

**表 7-6. MCU\_PORz Timing Requirements**

see [表 7-10](#)

NO.		MIN	TYP	MAX	UNIT
RST1	Hold time, MCU_PORz active (low) at Power-up after all MCU DOMAIN supplies valid (using external crystal)	N + 1200 <sup>(2)</sup>	9500000		ns
RST2	t <sub>h</sub> (MCUD_SUPPLIES_VALID - MCU_PORz) Hold time, MCU_PORz active (low) at Power-up after all MCU DOMAIN supplies <sup>(1)</sup> valid and external clock stable (using external LVCMOS oscillator)	1200			ns
RST3	t <sub>w</sub> (MCU_PORzL) Pulse Width minimum, MCU_PORz low after Power-up (without removal of Power or system reference clock MCU_OSC0_XI/XO)	1200			ns

- (1) For the definition of the MCU DOMAIN supplies, see the [セクション 7.10.2.2, Combined MCU and Main Domains Poewr-Up Sequencing](#).
- (2) N = oscillator start-up time

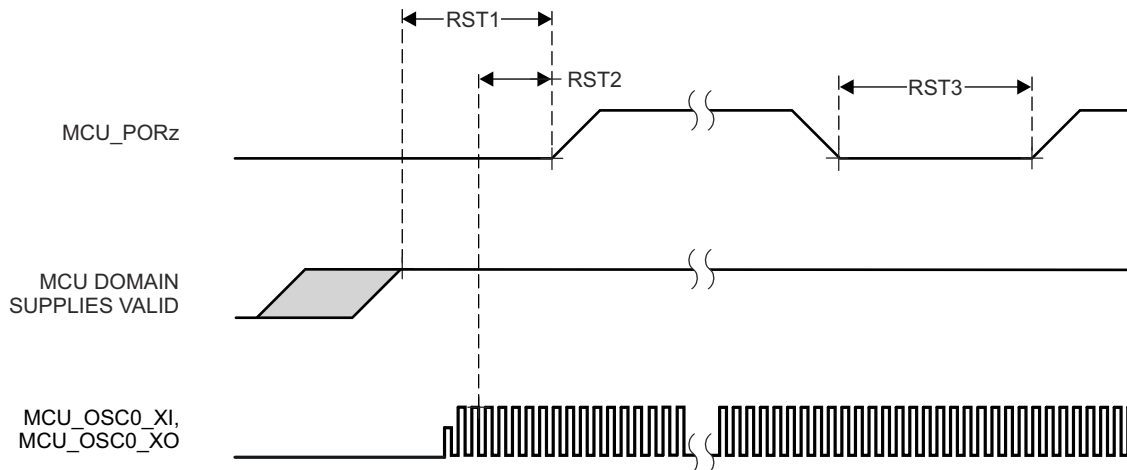

**図 7-10. MCU\_PORz Timing Requirements**

表 7-7. PORz Timing Requirements

see 図 7-11

NO.			MIN	MAX	UNIT
RST4	$t_{h(MAIN\_SUPPLIES\_VALID - PORz)}$	Hold time, PORz active (low) at Power-up after all MAIN DOMAIN supplies <sup>(1)</sup> valid	1200		ns
RST5	$t_{w(PORzL)}$	Pulse Width minimum, PORz low after Power-up	1200		ns

(1) For the definition of the MAIN DOMAIN supplies, see the セクション 7.10.2.2, Combined MCU and Main Domains Power-Up Sequencing.



図 7-11. PORz Timing Requirements

表 7-8. MCU\_PORz initiates; MCU\_PORz\_OUT, PORz\_OUT, MCU\_RESETSTATz, and RESETSTATz Switching Characteristics

see 図 7-12

NO.	PARAMETER	MODE	MIN	MAX	UNIT
RST6	$t_d(MCU\_PORzL-MCU\_PORz\_OUTL)$	Delay time, MCU_PORz active (low) to MCU_PORz_OUT active (low)	0		ns
RST7	$t_d(MCU\_PORzH-MCU\_PORz\_OUTH)$	Delay time, MCU_PORz inactive (high) to MCU_PORz_OUT inactive (high)	0		ns
RST8	$t_d(MCU\_PORzL-PORz\_OUTL)$	Delay time, MCU_PORz active (low) to PORz_OUT active (low)	0		ns
RST9	$t_d(MCU\_PORzH-PORz\_OUTH)$	Delay time, MCU_PORz inactive (high) to PORz_OUT inactive (high)	1500		ns
RST10	$t_d(MCU\_PORzL-MCU\_RESETSTATzL)$	Delay time, MCU_PORz active (low) to MCU_RESETSTATz active (low)	0		ns
RST11	$t_d(MCU\_PORzH-MCU\_RESETSTATzH)$	Delay time, MCU_PORz inactive (high) to MCU_RESETSTATz inactive (high)	POST bypass	12000*S <sup>(1)</sup>	ns
RST12	$t_d(MCU\_PORzL-RESETSTATzL)$	Delay time, MCU_PORz active (low) to RESETSTATz active (low)	0		ns
RST13	$t_d(MCU\_PORzH-RESETSTATzH)$	Delay time, MCU_PORz inactive (high) to RESETSTATz inactive (high)		14500*S <sup>(1)</sup>	ns
RST14	$t_w(MCU\_PORz\_OUTL)$	Pulse width minimum, MCU_PORz_OUT active (low)	1200		ns
RST15	$t_w(PORz\_OUTL)$	Pulse Width Minimum PORz_OUT low	2550		ns
RST16	$t_w(MCU\_RESETSTATzL)$	Pulse Width Minimum MCU_RESETSTATz low	3900*S <sup>(1)</sup>		ns
RST17	$t_w(RESETSTATzL)$	Pulse Width Minimum RESETSTATz low	2650*S <sup>(1)</sup>		ns

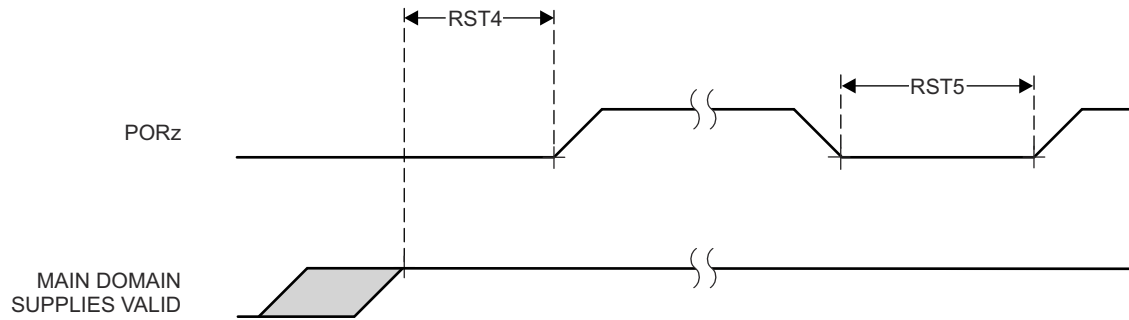
(1) S = MCU\_OSC0\_XI/XO clock period.

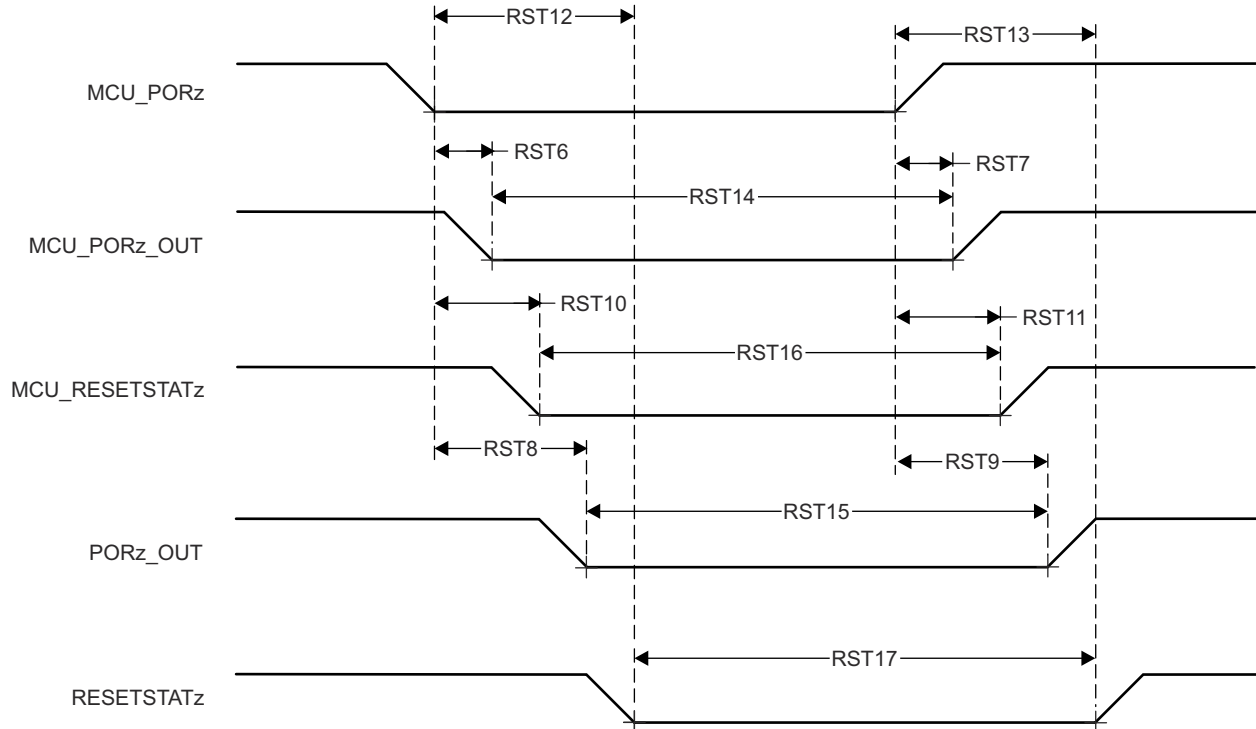

**7-12. MCU\_PORz initiates; MCU\_PORz\_OUT, PORz\_OUT, MCU\_RESETSTATz, and RESETSTATz Switching Characteristics**



表 7-9. PORz Initiates; PORz\_OUT and RESETSTATz Switching Characteristics

see 図 7-13

NO.	PARAMETER		MODE	MIN	MAX	UNIT
RST18	$t_{d(PORzL-PORz\_OUTL)}$	Delay time, PORz active (low) toPORz_OUT active (low)	software control of POR_RST_ISO_DONE_Z	$T^{(1)}$		
			CTRLMMR_WKUP_POR_RST_CTRL[0].POR_RST_ISO_DONE_Z = 0	0		ns
RST19	$t_{d(PORzH-PORz\_OUTH)}$	Delay time, PORz active (high) toPORz_OUT active (high)		1300		ns
RST20	$t_{d(PORzL-RESETSTATzL)}$	Delay time, PORz active (low) to RESETSTATz active (low)		$T^{(1)}$		
			CTRLMMR_WKUP_POR_RST_CTRL[0].POR_RST_ISO_DONE_Z = 0	0		ns
RST21	$t_{d(PORzH-RESETSTATzH)}$	Delay time, PORz active (high) to RESETSTATz active (high)		14500*S <sup>(2)</sup>		ns

- (1) T = Reset Isolation Time (Software Dependent).  
 (2) S = MCU\_OSC0\_XI/XO clock period.



図 7-13. PORz initiates; PORz\_OUT and RESETSTATz Switching Characteristics

**表 7-10. MCU\_RESETz Timing Requirements**

see [图 7-14](#)

NO.		MIN	MAX	UNIT
RST22	$t_{w(MCU\_RESETz)}$ <sup>(1)</sup>	1200		ns

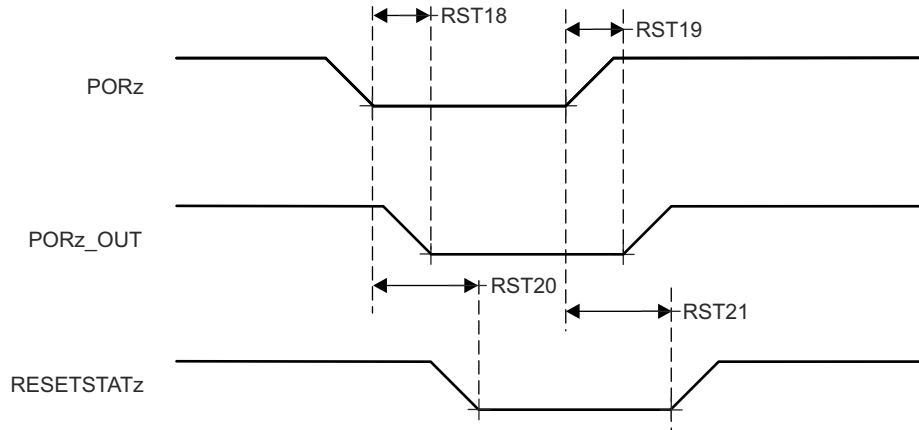
(1) Timing for MCU\_RESETz is valid only after all supplies are valid and MCU\_PORz has been asserted for the specified time.

**表 7-11. MCU\_RESETz initiates; MCU\_RESETSTATz, and RESETSTATz Switching Characteristics**

see [图 7-14](#)

NO.	PARAMETER	MIN	MAX	UNIT
RST23	$t_{d(MCU\_RESETzL-MCU\_RESETSTATzL)}$ Delay time, MCU_RESETz active (low) to MCU_RESETSTATz active (low)	800		ns
RST24	$t_{d(MCU\_RESETzH-MCU\_RESETSTATzH)}$ Delay time, MCU_RESETz inactive (high) to MCU_RESETSTATz inactive (high)	3900*S <sup>(1)</sup>		ns
RST25	$t_{d(MCU\_RESETzL-RESETSTATzL)}$ Delay time, MCU_RESETz active (low) to RESETSTATz active (low)	800		ns
RST26	$t_{d(MCU\_RESETzH-RESETSTATzH)}$ Delay time, MCU_RESETz inactive (high) to RESETSTATz inactive (high)	3900*S <sup>(1)</sup>		ns

(1) S = MCU\_OSC0\_XI/XO clock period.

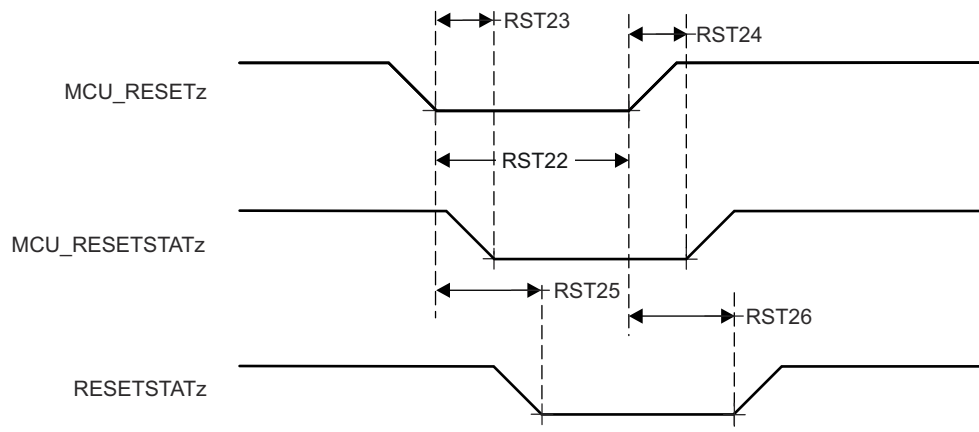

**图 7-14. MCU\_RESETz initiates; MCU\_RESETSTATz, and RESETSTATz Timing Requirements and Switching Characteristics**

ADVANCE INFORMATION

表 7-12. RESET\_REQz Timing Requirements

see 図 7-15

NO.		MIN	MAX	UNIT
RST27	$t_{w(RESSET\_REQzL)}$ <sup>(1)</sup> Pulse Width minimum, RESET_REQz active (low)	1200		ns

(1) Timing for RESET\_REQz is valid only after all supplies are valid and MCU\_PORz has been asserted for the specified time.

表 7-13. RESET\_REQz initiates; RESETSTATz Switching Characteristics

see 図 7-15

NO.	PARAMETER	MODE	MIN	MAX	UNIT
RST28	$t_{d(RESSET\_REQzL-RESSETSTATzL)}$ Delay time, RESET_REQz active (low) to RESETSTATz active (low)	software control of SOC_WARMRST_ISO_DONE_Z	T <sup>(1)</sup>		
		CTRLMMR_WKUP_MAIN_WARM_RST_CTRL[0].SOC_WARMRST_ISO_DONE_Z = 0	740		ns
RST29	$t_{d(RESSET\_REQzH-RESSETSTATzH)}$ Delay time, RESET_REQz inactive (high) to RESETSTATz inactive (high)		2650*S <sup>(2)</sup>		ns

- (1) T = Reset Isolation Time (Software Dependent).  
 (2) S = MCU\_OSC0\_XI/XO clock period.



図 7-15. RESET\_REQz initiates; RESETSTATz Timing Requirements and Switching Characteristics

**表 7-14. EMUx Timing Requirements**

see [图 7-16](#)

NO.			MIN	MAX	UNIT
RST30	$t_{su}(EMUx-MCU\_PORz)$	Setup time, EMU[1:0] before MCU_PORz inactive (high)	$3 \cdot S^{(1)}$		ns
RST31	$t_h(MCU\_PORz - EMUx)$	Hold time, EMU[1:0] after MCU_PORz inactive (high)	10		ns

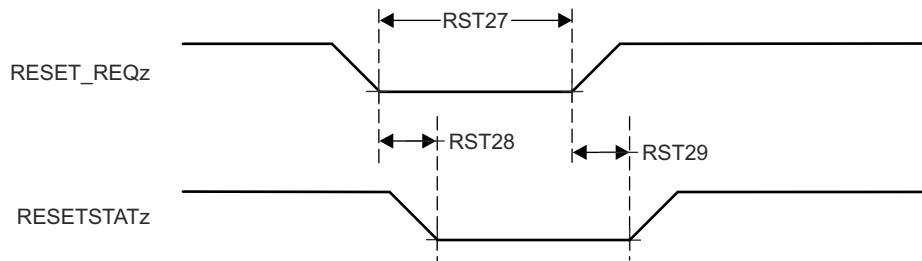
(1) S = MCU\_OSC0\_XI/XO clock period.

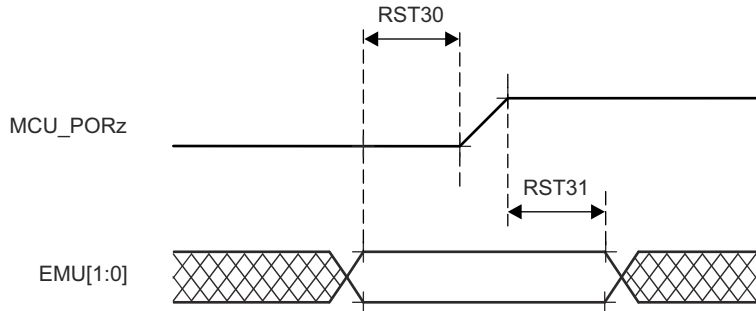

**图 7-16. EMUx Timing Requirements**

**表 7-15. MCU\_BOOTMODE Timing Requirements**

see [图 7-17](#)

NO.			MIN	MAX	UNIT
RST32	$t_{su}(MCU\_BOOTMODE-MCU\_PORz\_OUT)$	Setup time, MCU_BOOTMODE[09:00] before MCU_PORz_OUT high	$3 \cdot S^{(1)}$		ns
RST33	$t_h(MCU\_PORz\_OUT - MCU\_BOOTMODE)$	Hold time, MCU_BOOTMODE[09:00] after MCU_PORz_OUT high	0		ns

(1) S = MCU\_OSC0\_XI/XO clock period.

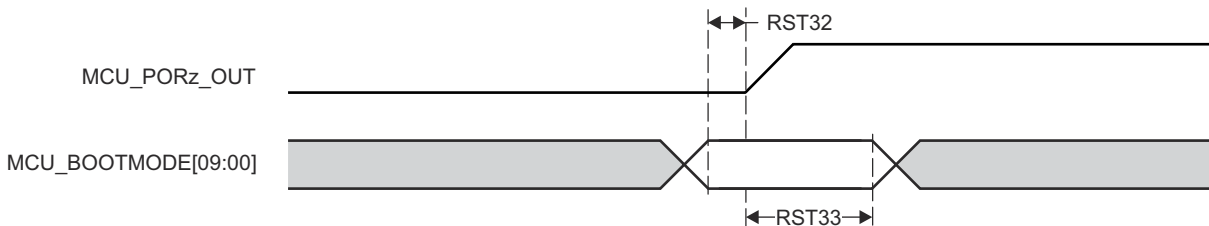

**图 7-17. MCU\_BOOTMODE Timing Requirements**

**表 7-16. BOOTMODE Timing Requirements**

see [図 7-18](#)

NO.			MIN	MAX	UNIT
RST34	$t_{su}(\text{BOOTMODE-PORz\_OUT})$	Setup time, BOOTMODE[7:0] before PORz_OUT high	$3 \cdot S^{(1)}$		ns
RST35	$t_h(\text{PORz\_OUT - BOOTMODE})$	Hold time, BOOTMODE[7:0] after PORz_OUT high	0		ns

(1) S = MCU\_OSC0\_XI/XO clock period.

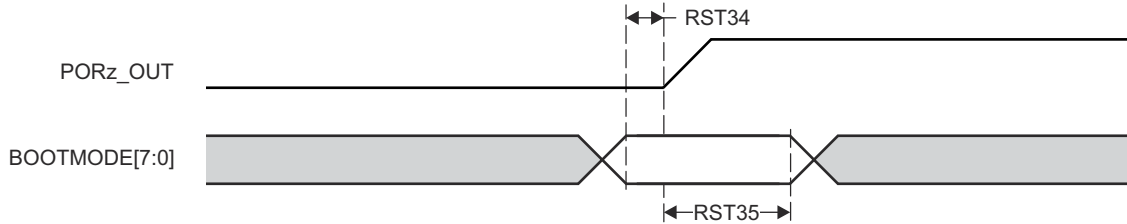

**図 7-18. BOOTMODE Timing Requirements**

### 7.10.3.2 Safety Signal Timing

Tables and figures provided in this section define switching characteristics for MCU\_SAFETY\_ERRORn and SOC\_SAFETY\_ERRORn.

**表 7-17. MCU\_SAFETY\_ERRORn Switching Characteristics**

see [图 7-19](#)

NO.	PARAMETER	MIN	MAX	UNIT
SFTY1	$t_{w(\text{MCU\_SAFETY\_ERRORn})}$ Pulse width minimum, MCU_SAFETY_ERRORn active (PWM mode disabled)	$P \cdot R^{(1) (2)}$		ns
SFTY2	$t_{d(\text{ERROR\_CONDITION-MCU\_SAFETY\_ERRORnL})}$ Delay time, ERROR CONDITION to MCU_SAFETY_ERRORn active	$50 \cdot P^{(1)}$		ns

- (1) P = ESM functional clock (MCU\_SYSCCLK0 /6).  
 (2) R = Error Pin Counter Pre-Load Register count value.

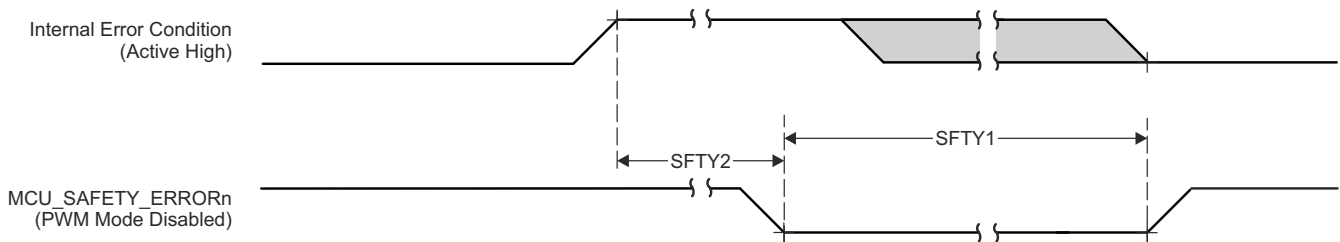

**图 7-19. MCU\_SAFETY\_ERRORn Switching Characteristics**

**表 7-18. SOC\_SAFETY\_ERRORn Switching Characteristics**

see [图 7-20](#)

NO.	PARAMETER	MIN	MAX	UNIT
SFTY3	$t_{w(\text{SOC\_SAFETY\_ERRORn})}$ Pulse width minimum, SOC_SAFETY_ERRORn active (PWM mode disabled)	$P \cdot R^{(1) (2)}$		ns
SFTY4	$t_{d(\text{ERROR\_CONDITION-SOC\_SAFETY\_ERRORnL})}$ Delay time, ERROR CONDITION to SOC_SAFETY_ERRORn active	$50 \cdot P^{(1)}$		ns

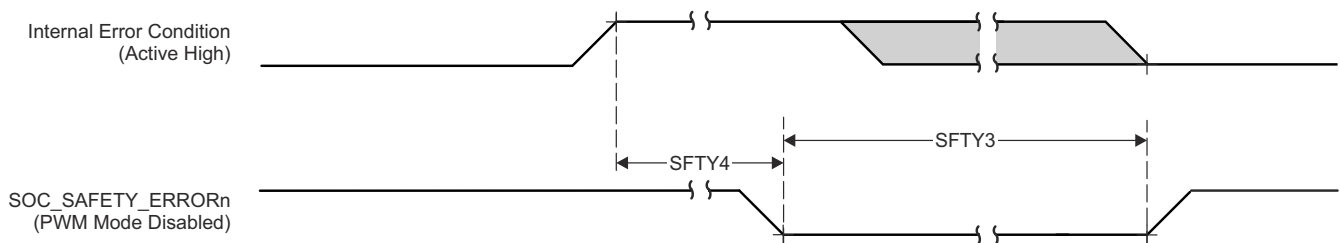

**图 7-20. SOC\_SAFETY\_ERRORn Switching Characteristics**

ADVANCE INFORMATION

### 7.10.3.3 Clock Timing

Tables and figures provided in this section define timing requirements and switching characteristics for clock signals.

表 7-19. Clock Timng Requiements

see 図 7-21

NO.			MIN	MAX	UNIT
CLK1	$t_{c}(EXT\_REFCLK1)$	Cycle time minimum, EXT_REFCLK1	10		ns
CLK2	$t_{w}(EXT\_REFCLK1H)$	Pulse Duration minimum, EXT_REFCLK1 high	$E*0.45^{(1)}$	$E*0.55^{(1)}$	ns
CLK3	$t_{w}(EXT\_REFCLK1L)$	Pulse Duration minimum, EXT_REFCLK1 low	$E*0.45^{(1)}$	$E*0.55^{(1)}$	ns

(1) E = EXT\_REFCLK1 cycle time.



図 7-21. Clock Timing Requirements

表 7-20. Clock Switching Characteristics

see 図 7-22

NO.	PARAMETER		MIN	MAX	UNIT
CLK4	$t_{c}(SYSCLKOUT0)$	Cycle time minimum, SYSCLKOUT0	8		ns
CLK5	$t_{w}(SYSCLKOUT0H)$	Pulse Duration minimum, SYSCLKOUT0 high	$A*0.4^{(1)}$	$A*0.6^{(1)}$	ns
CLK6	$t_{w}(SYSCLKOUT0L)$	Pulse Duration minimum, SYSCLKOUT0 low	$A*0.4^{(1)}$	$A*0.6^{(1)}$	ns
CLK7	$t_{c}(OBCLK0)$	Cycle time minimum, OBCLK0	5		ns
CLK8	$t_{w}(OBCLK0H)$	Pulse Duration minimum, OBCLK0 high	$B*0.4^{(2)}$	$B*0.6^{(2)}$	ns
CLK9	$t_{w}(OBCLK0L)$	Pulse Duration minimum, OBCLK0 low	$B*0.4^{(2)}$	$B*0.6^{(2)}$	ns
CLK10	$t_{c}(CLKOUT0)$	Cycle time minimum, CLKOUT0	20		ns
CLK11	$t_{w}(CLKOUT0H)$	Pulse Duration minimum, CLKOUT0 high	$C*0.4^{(3)}$	$C*0.6^{(3)}$	ns
CLK12	$t_{w}(CLKOUT0L)$	Pulse Duration minimum, CLKOUT0 low	$C*0.4^{(3)}$	$C*0.6^{(3)}$	ns

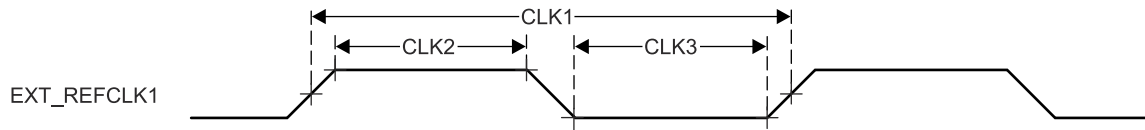
(1) A = SYSCLKOUT0 cycle time.

(2) B = OBCLK0 cycle time.

(3) C = CLKOUT0 cycle time.



図 7-22. Clock Switching Characteristics

## 7.10.4 Clock Specifications

### 7.10.4.1 Input and Output Clocks / Oscillators

Various external clock inputs/outputs are needed to drive the device. Summary of these input clock signals is as follows:

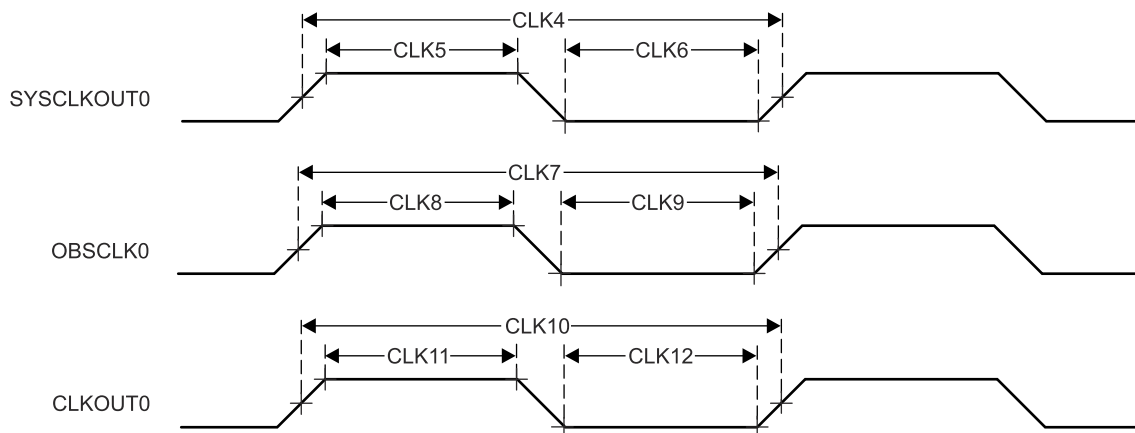
- High frequency oscillators inputs
  - OSC1\_XO/OSC1\_XI — external main crystal interface pins connected to internal oscillator which sources reference clock. Provides reference clock to PLLs within MCU domain and MAIN domain. This high-frequency oscillator is used to provide audio clock frequencies to MCASPs.
  - WKUP\_OSC0\_XO/WKUP\_OSC0\_XI — external main crystal interface pins connected to internal oscillator which sources reference clock. Provides reference clock to PLLs within WKUP and MAIN domain.
- Low frequency digital input
  - WKUP\_LF\_CLKIN - Low Frequency 32k digital clock input, optionally sourced from an external PMIC or other clock source. This SoC does not support a LFOSC crystal input.
- General purpose clock inputs
  - MCU\_EXT\_REFCLK0 - optional external System clock input (MCU domain).
  - EXT\_REFCLK1 — optional external System clock input (MAIN domain).
- Peripheral clocks - refer to the Signal Descriptions for peripheral specific clocks

For more information about Input clock interfaces, see *Clocking* section in *Device Configuration* chapter in the device TRM.

#### 7.10.4.1.1 WKUP\_OSC0 Internal Oscillator Clock Source

 7-23 shows the recommended crystal circuit. All discrete components used to implement the oscillator circuit should be placed as close as possible to the WKUP\_OSC0\_XI and WKUP\_OSC0\_XO pins.

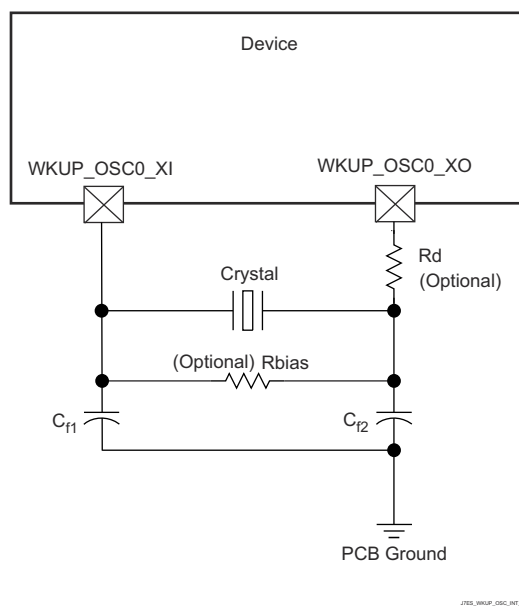

 7-23. WKUP\_OSC0 Crystal Implementation

The crystal must be in the fundamental mode of operation and parallel resonant. 表 7-21 summarizes the required electrical constraints.

表 7-21. WKUP\_OSC0 Crystal Electrical Characteristics

PARAMETER		MIN	TYP	MAX	UNIT
F <sub>xtal</sub>	Crystal Parallel Resonance Frequency	19.2, 20, 24, 25, 26, 27			MHz



表 7-21. WKUP\_OSC0 Crystal Electrical Characteristics (continued)

PARAMETER		MIN	TYP	MAX	UNIT
F <sub>x<sub>tal</sub></sub>	Crystal Frequency Stability and Tolerance	Ethernet RGMII and RMII not used		±100	ppm
		Ethernet RGMII and RMII using derived clock		±50	
C <sub>L1+PCBXI</sub>	Capacitance of C <sub>L1</sub> + C <sub>PCBXI</sub>	12		24	pF
C <sub>L2+PCBXO</sub>	Capacitance of C <sub>L2</sub> + C <sub>PCBXO</sub>	12		24	pF
C <sub>L</sub>	Crystal Load Capacitance	6		12	pF
C <sub>shunt</sub>	Crystal Circuit Shunt Capacitance	ESR <sub>x<sub>tal</sub></sub> = 30 Ω	19.2 MHz, 20 MHz, 24 MHz, 25 MHz, 26 MHz, 27 MHz	7	pF
		ESR <sub>x<sub>tal</sub></sub> = 40 Ω	19.2 MHz, 20 MHz, 24 MHz, 25 MHz, 26 MHz, 27 MHz	5	pF
		ESR <sub>x<sub>tal</sub></sub> = 50 Ω	19.2 MHz, 20 MHz, 24 MHz, 25 MHz, 26 MHz, 27 MHz	5	pF
		ESR <sub>x<sub>tal</sub></sub> = 60 Ω	19.2 MHz, 20 MHz, 24 MHz	5	pF
		ESR <sub>x<sub>tal</sub></sub> = 80 Ω	19.2 MHz, 20 MHz	5	pF
			25 MHz	3	pF
ESR <sub>x<sub>tal</sub></sub> = 100 Ω	19.2 MHz, 20 MHz	3	pF		
ESR <sub>x<sub>tal</sub></sub>	Crystal Effective Series Resistance			100	Ω

When selecting a crystal, the system design must consider the temperature and aging characteristics of a based on the worst case environment and expected life expectancy of the system.

表 7-22 details the switching characteristics of the oscillator and the requirements of the input clock.

表 7-22. WKUP\_OSC0 Switching Characteristics – Crystal Mode

PARAMETER		MIN	TYP	MAX	UNIT
C <sub>XI</sub>	XI Capacitance			1.55	pF
C <sub>XO</sub>	XO Capacitance			1.35	pF
C <sub>XIXO</sub>	XI to XO Mutual Capacitance			0.9	fF
t <sub>s</sub>	Maximum Start-up Time		9.5 <sup>(1)</sup>		ms

- (1) TI strongly encourages each customer to submit samples of the device to the resonator/crystal vendors for validation. The vendors are equipped to determine what load capacitors will best tune their resonator/crystal to the microcontroller device for optimum startup and operation over temperature/voltage extremes.

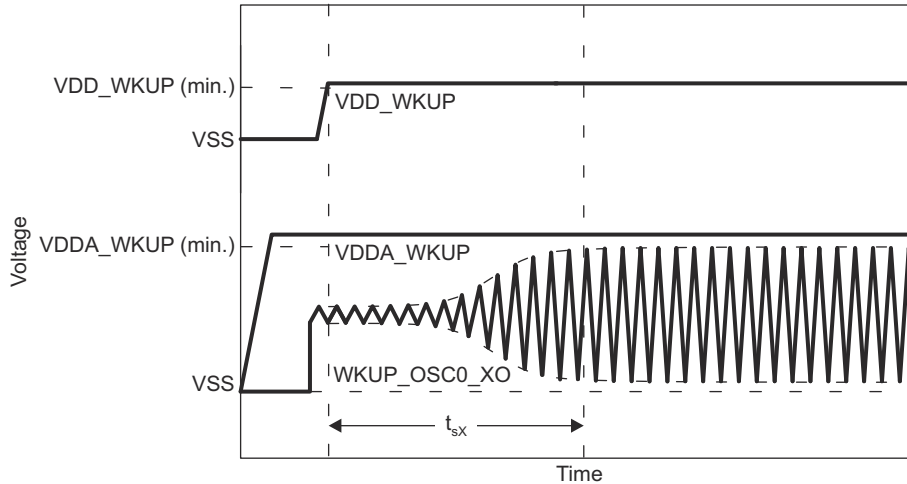

7-24. WKUP\_OSC0 Start-up Time

#### 7.10.4.1.1.1 Load Capacitance

The crystal circuit must be designed such that it applies the appropriate capacitive load to the crystal, as defined by the crystal manufacturer. The capacitive load,  $C_L$ , of this circuit is a combination of discrete capacitors  $C_{L1}$ ,  $C_{L2}$ , and several parasitic contributions. PCB signal traces which connect crystal circuit components to WKUP\_OSC0\_XI and WKUP\_OSC0\_XO have parasitic capacitance to ground,  $C_{PCBXI}$  and  $C_{PCBXO}$ , where the PCB designer should be able to extract parasitic capacitance for each signal trace. The WKUP\_OSC0 circuits and device package have combined parasitic capacitance to ground,  $C_{PCBXI}$  and  $C_{PCBXO}$ , where these parasitic capacitance values are defined in 表 7-22.

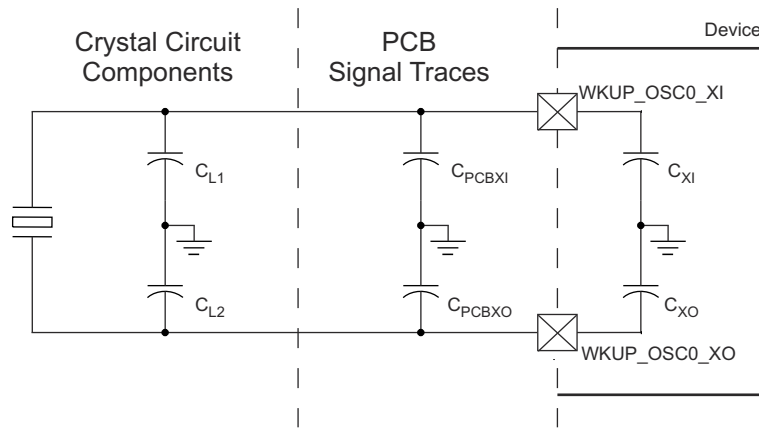

7-25. Load Capacitance

Load capacitors,  $C_{L1}$  and  $C_{L2}$  in 7-23, should be chosen such that the below equation is satisfied.  $C_L$  in the equation is the load specified by the crystal manufacturer.

$$C_L = [(C_{L1} + C_{PCBXI} + C_{XI}) \times (C_{L2} + C_{PCBXO} + C_{XO})] / [(C_{L1} + C_{PCBXI} + C_{XI}) + (C_{L2} + C_{PCBXO} + C_{XO})]$$

To determine the value of  $C_{L1}$  and  $C_{L2}$ , multiply the capacitive load value  $C_L$  by 2. Using this result, subtract the combined values of  $C_{PCBXI} + C_{XI}$  to determine the value of  $C_{L1}$  and the combined values of  $C_{PCBXO} + C_{XO}$  to determine the value of  $C_{L2}$ . For example, if  $C_L = 10$  pF,  $C_{PCBXI} = 2.9$  pF,  $C_{XI} = 0.5$  pF,  $C_{PCBXO} = 3.7$  pF,  $C_{XO} = 0.5$  pF, the value of  $C_{L1} = [(2C_L) - (C_{PCBXI} + C_{XI})] = [(2 \times 10 \text{ pF}) - 2.9 \text{ pF} - 0.5 \text{ pF}] = 16.6$  pF and  $C_{L2} = [(2C_L) - (C_{PCBXO} + C_{XO})] = [(2 \times 10 \text{ pF}) - 3.7 \text{ pF} - 0.5 \text{ pF}] = 15.8$  pF

#### 7.10.4.1.1.2 Shunt Capacitance

The crystal circuit must also be designed such that it does not exceed the maximum shunt capacitance for WKUP\_OSC0 operating conditions defined in 表 7-21. Shunt capacitance,  $C_{shunt}$ , of the crystal circuit is a combination of crystal shunt capacitance and parasitic contributions. PCB signal traces which connect crystal circuit components to WKUP\_OSC0 have mutual parasitic capacitance to each other,  $C_{PCBXIXO}$ , where the PCB designer should be able to extract mutual parasitic capacitance between these signal traces. The device package also has mutual parasitic capacitance,  $C_{XIXO}$ , where this mutual parasitic capacitance value is defined in 表 7-22.

PCB routing should be designed to minimize mutual capacitance between XI and XO signal traces. This is typically done by keeping signal traces short and not routing them in close proximity. Mutual capacitance can also be minimized by placing a ground trace between these signals when the layout requires them to be routed in close proximity. It is important to minimize the mutual capacitance on the PCB to provide as much margin as possible when selecting a crystal.



图 7-26. Shunt Capacitance

A crystal should be chosen such that the below equation is satisfied.  $C_0$  in the equation is the maximum shunt capacitance specified by the crystal manufacturer.

$$C_{shunt} \geq C_0 + C_{PCBXIXO} + C_{XIXO}$$

For example, the equation would be satisfied when the crystal being used is 25 MHz with an ESR = 30  $\Omega$ ,  $C_{PCBXIXO} = 0.04$  pF,  $C_{XIXO} = 0.01$  pF, and shunt capacitance of the crystal is less than or equal to 6.95 pF.

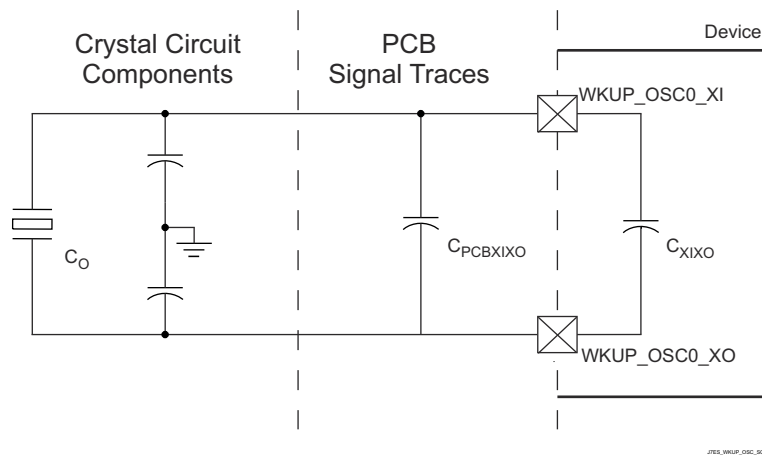
#### 7.10.4.1.2 WKUP\_OSC0 LVCMOS Digital Clock Source

图 7-27 shows the recommended oscillator connections when WKUP\_OSC0\_XI is connected to a 1.8-V LVCMOS square-wave digital clock source.

#### 注

A DC steady-state condition is not allowed on WKUP\_OSC0\_XI when the oscillator is powered up. This is not allowed because WKUP\_OSC0\_XI is internally AC coupled to a comparator that may enter a unknown state when DC is applied to the input. Therefore, application software should power down WKUP\_OSC0 any time WKUP\_OSC0\_XI is not toggling between logic states.

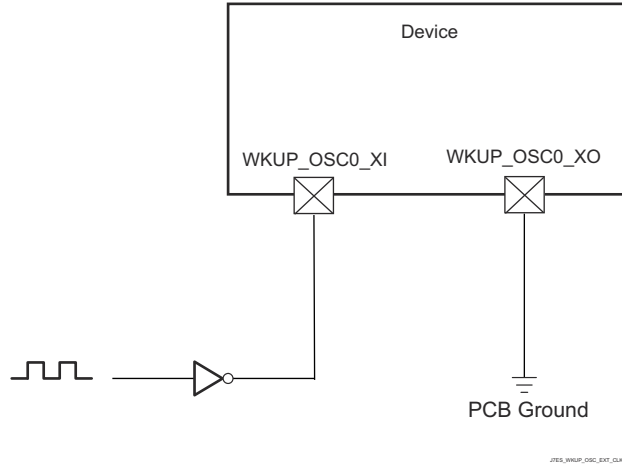

**7-27. 1.8-V LVC MOS-Compatible Clock Input**

**7.10.4.1.3 Auxiliary OSC1 Internal Oscillator Clock Source**

7-28 shows the recommended crystal circuit. All discrete components used to implement the oscillator circuit should be placed as close as possible to the OSC1\_XI and OSC1\_XO pins.

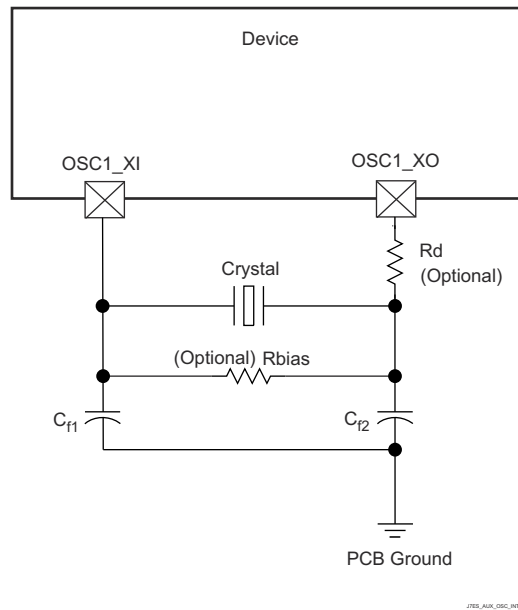

**7-28. OSC1 Crystal Implementation**

The crystal must be in the fundamental mode of operation and parallel resonant. 表 7-23 summarizes the required electrical constraints.

**表 7-23. OSC1 Crystal Electrical Characteristics**

PARAMETER		MIN	TYP	MAX	UNIT
F <sub>xtal</sub>	Crystal Parallel Resonance Frequency	19.2		27	MHz
F <sub>xtal</sub>	Crystal Frequency Stability and Tolerance	Ethernet RGMII and RMII not used		±100	ppm
		Ethernet RGMII and RMII using derived clock		±50	
C <sub>L1+PCBXI</sub>	Capacitance of C <sub>L1</sub> + C <sub>PCBXI</sub>	12		24	pF
C <sub>L2+PCBXO</sub>	Capacitance of C <sub>L2</sub> + C <sub>PCBXO</sub>	12		24	pF
C <sub>L</sub>	Crystal Load Capacitance	6		12	pF
C <sub>shunt</sub>	Crystal Circuit Shunt Capacitance	ESR <sub>xtal</sub> = 30 Ω	19.2 MHz, 20 MHz, 24 MHz, 25 MHz, 26 MHz, 27 MHz	7	pF
		ESR <sub>xtal</sub> = 40 Ω	19.2 MHz, 20 MHz, 24 MHz, 25 MHz, 26 MHz, 27 MHz	5	pF
		ESR <sub>xtal</sub> = 50 Ω	19.2 MHz, 20 MHz, 24 MHz, 25 MHz, 26 MHz, 27 MHz	5	pF
		ESR <sub>xtal</sub> = 60 Ω	19.2 MHz, 20 MHz, 24 MHz	5	pF
		ESR <sub>xtal</sub> = 80 Ω	19.2 MHz, 20 MHz	5	pF
			25 MHz	3	pF
ESR <sub>xtal</sub> = 100 Ω	19.2 MHz, 20 MHz	3	pF		
ESR <sub>xtal</sub>	Crystal Effective Series Resistance			100	Ω

When selecting a crystal, the system design must consider the temperature and aging characteristics of a based on the worst case environment and expected life expectancy of the system.

表 7-24 details the switching characteristics of the oscillator and the requirements of the input clock.

**表 7-24. OSC1 Switching Characteristics – Crystal Mode**

PARAMETER		MIN	TYP	MAX	UNIT
C <sub>XI</sub>	XI Capacitance			1.55	pF
C <sub>XO</sub>	XO Capacitance			1.35	pF
C <sub>XIXO</sub>	XI to XO Mutual Capacitance			0.9	fF
t <sub>s</sub>	Maximum Start-up Time		9.5 <sup>(1)</sup>		ms

- (1) TI strongly encourages each customer to submit samples of the device to the resonator/crystal vendors for validation. The vendors are equipped to determine what load capacitors will best tune their resonator/crystal to the microcontroller device for optimum startup and operation over temperature/voltage extremes.

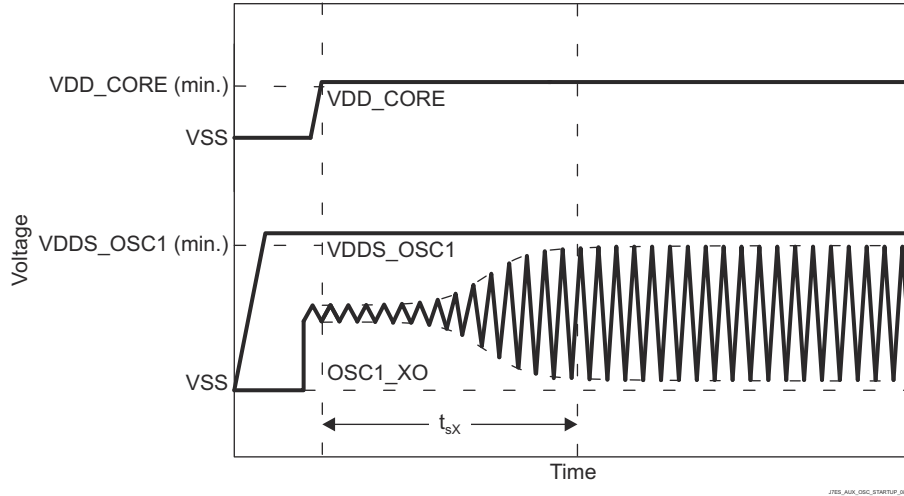

7-29. OSC1 Start-up Time

#### 7.10.4.1.3.1 Load Capacitance

The crystal circuit must be designed such that it applies the appropriate capacitive load to the crystal, as defined by the crystal manufacturer. The capacitive load,  $C_L$ , of this circuit is a combination of discrete capacitors  $C_{L1}$ ,  $C_{L2}$ , and several parasitic contributions. PCB signal traces which connect crystal circuit components to OSC1\_XI and OSC1\_XO have parasitic capacitance to ground,  $C_{PCBXI}$  and  $C_{PCBXO}$ , where the PCB designer should be able to extract parasitic capacitance for each signal trace. The OSC1 circuits and device package have combined parasitic capacitance to ground,  $C_{PCBXI}$  and  $C_{PCBXO}$ , where these parasitic capacitance values are defined in 表 7-24.

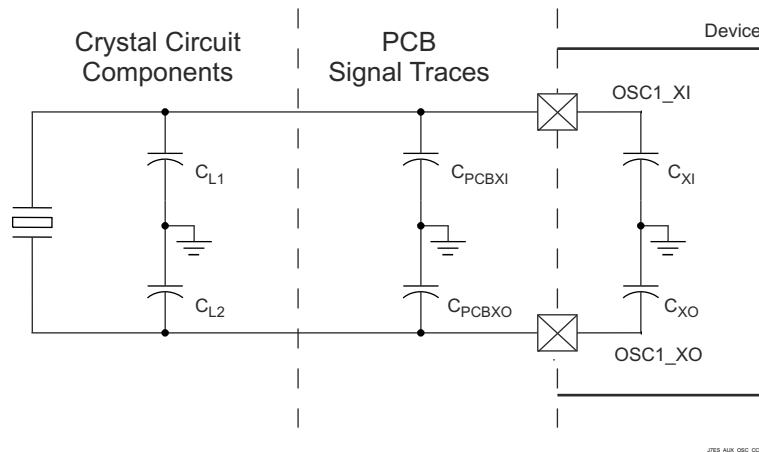

7-30. Load Capacitance

Load capacitors,  $C_{L1}$  and  $C_{L2}$  in 7-28, should be chosen such that the below equation is satisfied.  $C_L$  in the equation is the load specified by the crystal manufacturer.

$$C_L = [(C_{L1} + C_{PCBXI} + C_{XI}) \times (C_{L2} + C_{PCBXO} + C_{XO})] / [(C_{L1} + C_{PCBXI} + C_{XI}) + (C_{L2} + C_{PCBXO} + C_{XO})]$$

To determine the value of  $C_{L1}$  and  $C_{L2}$ , multiply the capacitive load value  $C_L$  by 2. Using this result, subtract the combined values of  $C_{PCBXI} + C_{XI}$  to determine the value of  $C_{L1}$  and the combined values of  $C_{PCBXO} + C_{XO}$  to determine the value of  $C_{L2}$ . For example, if  $C_L = 10$  pF,  $C_{PCBXI} = 2.9$  pF,  $C_{XI} = 0.5$  pF,  $C_{PCBXO} = 3.7$  pF,  $C_{XO} = 0.5$  pF, the value of  $C_{L1} = [(2C_L) - (C_{PCBXI} + C_{XI})] = [(2 \times 10 \text{ pF}) - 2.9 \text{ pF} - 0.5 \text{ pF}] = 16.6$  pF and  $C_{L2} = [(2C_L) - (C_{PCBXO} + C_{XO})] = [(2 \times 10 \text{ pF}) - 3.7 \text{ pF} - 0.5 \text{ pF}] = 15.8$  pF

#### 7.10.4.1.3.2 Shunt Capacitance

The crystal circuit must also be designed such that it does not exceed the maximum shunt capacitance for OSC1 operating conditions defined in 表 7-23. Shunt capacitance,  $C_{shunt}$ , of the crystal circuit is a combination of crystal shunt capacitance and parasitic contributions. PCB signal traces which connect crystal circuit components to OSC1 have mutual parasitic capacitance to each other,  $C_{PCBXIXO}$ , where the PCB designer should be able to extract mutual parasitic capacitance between these signal traces. The device package also has mutual parasitic capacitance,  $C_{XIXO}$ , where this mutual parasitic capacitance value is defined in 表 7-24.

PCB routing should be designed to minimize mutual capacitance between XI and XO signal traces. This is typically done by keeping signal traces short and not routing them in close proximity. Mutual capacitance can also be minimized by placing a ground trace between these signals when the layout requires them to be routed in close proximity. It is important to minimize the mutual capacitance on the PCB to provide as much margin as possible when selecting a crystal.



图 7-31. Shunt Capacitance

A crystal should be chosen such that the below equation is satisfied.  $C_0$  in the equation is the maximum shunt capacitance specified by the crystal manufacturer.

$$C_{shunt} \geq C_0 + C_{PCBXIXO} + C_{XIXO}$$

For example, the equation would be satisfied when the crystal being used is 25 MHz with an ESR = 30  $\Omega$ ,  $C_{PCBXIXO} = 0.04$  pF,  $C_{XIXO} = 0.01$  pF, and shunt capacitance of the crystal is less than or equal to 6.95 pF.

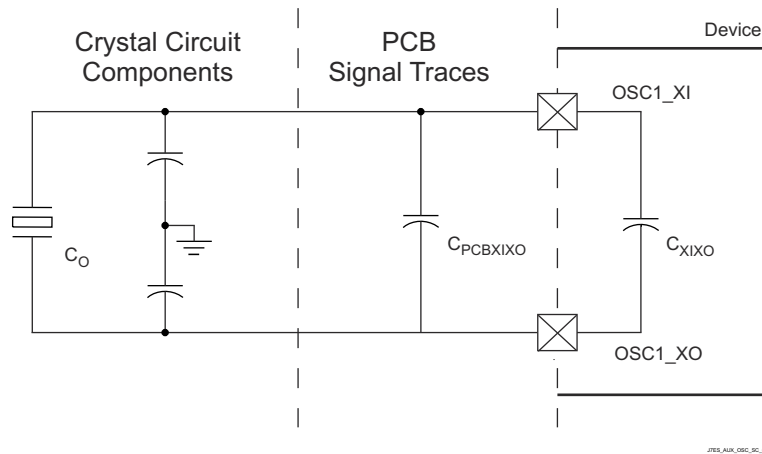
#### 7.10.4.1.4 Auxiliary OSC1 LVCMOS Digital Clock Source

图 7-32 shows the recommended oscillator connections when OSC1 is connected to a 1.8-V LVCMOS square-wave digital clock source.

#### 注

A DC steady-state condition is not allowed on OSC1\_XI when the oscillator is powered up. This is not allowed because OSC1\_XI is internally AC coupled to a comparator that may enter a unknown state when DC is applied to the input. Therefore, application software should power down OSC1 any time OSC1\_XI is not toggling between logic states.

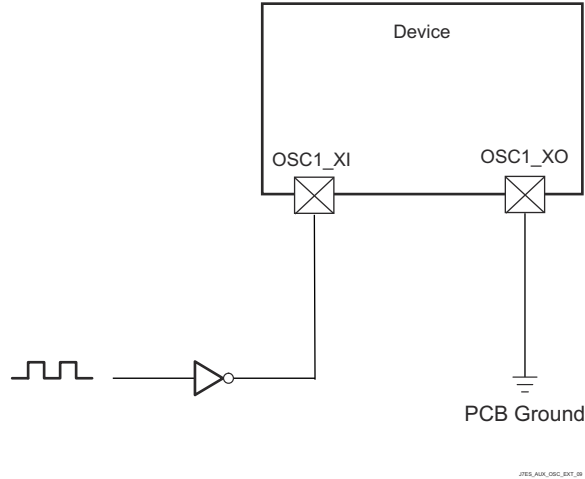

7-32. 1.8-V LVCMOS-Compatible Clock Input

#### 7.10.4.1.5 Auxiliary OSC1 Not Used

7-33 shows the recommended oscillator connections when OSC1 is not used. OSC1\_XI must be connected to VSS through an external pull resistor ( $R_{pd}$ ) to ensure this input is held to a valid low level when unused since the internal pull-down resistor is disabled by default.

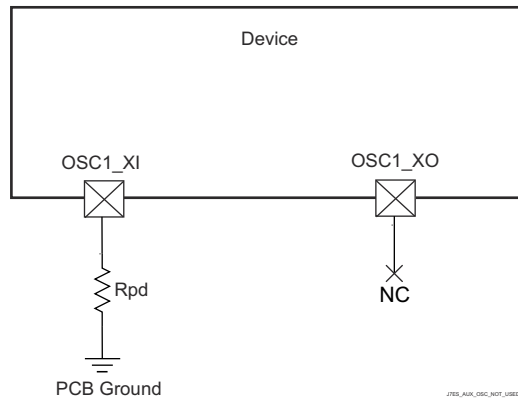

7-33. OSC1 Not Used

#### 7.10.4.2 Output Clocks

The device provides several system clock outputs. Summary of these output clocks are as follows:

- **MCU\_CLKOUT0**
  - Reference clock output for Ethernet PHYs (50 MHz or 25 MHz)
- **MCU\_SYSCLOCKOUT0**
  - MCU\_SYSCLOCK0 is divided by 4 and then sent out of the device as a LVCMOS clock signal (MCU\_SYSCLOCKOUT0). This signal can be used to test if the main chip clock is functioning or not. This signal should not be used as a clock source for external devices on a board.
- **MCU\_OBSCLK0**
  - On the clock output MCU\_OBSCLK0, oscillators and PLLs clocks can be observed for tests and debug. This signal should not be used as a clock source for external devices on a board.
- **SYSCLOCKOUT0**
  - SYSCLOCK0 is divided by 4 and then sent out of the device as a LVCMOS clock signal (SYSCLOCKOUT0). This signal can be used to test if the main chip clock is functioning or not. This signal should not be used as a clock source for external devices on a board.



- **CLKOUT**
  - Reference clock output for Ethernet PHYs (50 MHz)
- **OBSCLK[1:0]**
  - On the clock output OBSCLK0/1, oscillators and PLLs clocks can be observed for tests and debug.

### 7.10.4.3 PLLs

Power is supplied to the Phase-Locked Loop circuitries (PLLs) by internal regulators that derive power from the off-chip power-supply.

There are total of three PLLs in the device in WKUP and MCU domains:

- MCU\_PLL0 (MCU R5FSS PLL) with WKUP\_PLLCTRL0
- MCU\_PLL1 (MCU PERIPHERAL PLL)
- MCU\_PLL2 (MCU CPSW PLL)

There are total of twenty PLLs in the device in MAIN domain:

- PLL0 (MAIN PLL) with PLLCTRL0
- PLL1 (PER0 PLL)
- PLL2 (PER1 PLL)
- PLL3 (CPSW9G PLL)
- PLL4 (AUDIO0 PLL)
- PLL5 (VIDEO PLL)
- PLL6 (GPU PLL)
- PLL7 (C7x PLL)
- PLL8 (ARM0 PLL)
- PLL12 (DDR PLL)
- PLL13 (C66 PLL)
- PLL14 (R5F PLL)
- PLL15 (AUDIO1 PLL)
- PLL16 (DSS PLL0)
- PLL17 (DSS PLL1)
- PLL18 (DSS PLL2)
- PLL19 (DSS PLL3)
- PLL23 (DSS PLL7)
- PLL24 (MLB PLL)
- PLL25 (VISION PLL)

---

注

For more information, see:

- *Device Configuration / Clocking / PLLs* section in the device TRM.
  - *Peripherals / Display Subsystem Overview* section in the device TRM.
- 

---

注

The input reference clock (OSC1\_XI/OSC1\_XO) is specified and the lock time is ensured by the PLL controller, as documented in the *Device Configuration* chapter in the device TRM.

---

### 7.10.4.4 Module and Peripheral Clocks Frequencies

セクション 7.10.5, *Peripherals* section documents the maximum frequency associated with the peripheral clocks of the device.

For more details on the clocking structure of each module, reference *Device Configurations* chapter in the device TRM.

## 7.10.5 Peripherals

### 7.10.5.1 ATL

The device contains ATL module that can be used for asynchronous sample rate conversion of audio. The ATL calculates the error between two time bases, such as audio syncs, and optionally generates an averaged clock using cycle stealing via software.

#### 注

For more information about ATL, see *Audio Tracking Logic (ATL)* section in *Peripherals* chapter in the device TRM.

表 7-25 represents ATL timing conditions.

表 7-25. ATL Timing Conditions

PARAMETER		MODE	MIN	MAX	UNIT
<b>INPUT CONDITIONS</b>					
SR <sub>I</sub>	Input slew rate	External reference CLK	0.5	5	V/ns
<b>OUTPUT CONDITIONS</b>					
C <sub>L</sub>	Output load capacitance	Internal reference CLK	1	10	pF

セクション 7.10.5.1.1, セクション 7.10.5.1.2, セクション 7.10.5.1.3, and セクション 7.10.5.1.4 present timing requirements and switching characteristics for ATL.

#### 7.10.5.1.1 ATL\_PCLK Timing Requirements

NO.	PARAMETER	MODE	MIN	MAX	UNIT
D1	t <sub>c(pclk)</sub>	Cycle time, ATL_PCLK		5	ns
D2	t <sub>w(pclkL)</sub>	Pulse Duration, ATL_PCLK low	External reference CLK	0.45 × M <sup>(1)</sup> + 2.5	ns
D3	t <sub>w(pclkH)</sub>	Pulse Duration, ATL_PCLK high	External reference CLK	0.45 × M <sup>(1)</sup> + 2.5	ns

(1) M = ATL\_CLK[x] period

#### 7.10.5.1.2 ATL\_AWS[x] Timing Requirements

NO.	PARAMETER	MODE	MIN	MAX	UNIT
D4	t <sub>c(aws)</sub>	Cycle Time, ATL_AWS[x] <sup>(3)</sup>	External reference CLK	2 × M <sup>(1)</sup>	ns
D5	t <sub>w(awsL)</sub>	Pulse Duration, ATL_AWS[x] <sup>(3)</sup> low	External reference CLK	0.45 × A <sup>(2)</sup> + 2.5	ns
D6	t <sub>w(awsH)</sub>	Pulse Duration, ATL_AWS[x] <sup>(3)</sup> high	External reference CLK	0.45 × A <sup>(2)</sup> + 2.5	ns

(1) M = ATL\_CLK[x] period

(2) A = ATL\_AWS[x] period

(3) x = 0 to 3

#### 7.10.5.1.3 ATL\_BWS[x] Timing Requirements

NO.	PARAMETER	MODE	MIN	MAX	UNIT
D7	t <sub>c(bws)</sub>	Cycle Time, ATL_BWS[x] <sup>(3)</sup>	External reference clock	2 × M <sup>(1)</sup>	ns
D8	t <sub>w(bwsL)</sub>	Pulse Duration, ATL_BWS[x] low <sup>(3)</sup>	External reference clock	0.45 × B <sup>(2)</sup> + 2.5	ns

NO.			MODE	MIN	MAX	UNIT
D9	$t_{w(bwsH)}$	Pulse Duration, ATCL_BWS[x] high <sup>(3)</sup>	External reference clock	$0.45 \times B^{(2)} + 2.5$		ns

- (1) M = ATCL\_CLK[x] period
- (2) B = ATCL\_BWS[x] period
- (3) x = 0 to 3

#### 7.10.5.1.4 ATCLK[x] Switching Characteristics

NO.	PARAMETER		MODE	MIN	MAX	UNIT
D10	$t_{c(atclk)}$	Cycle time, ATCLK[x] <sup>(3)</sup>	Internal reference CLK	20		ns
D11	$t_{w(atclkL)}$	Pulse Duration, ATCLK[x] low <sup>(3)</sup>	Internal reference CLK	$0.45 \times P^{(2)} - M^{(1)} - 0.3$		ns
D12	$t_{w(atclkH)}$	Pulse Duration, ATCLK[x] high <sup>(3)</sup>	Internal reference CLK	$0.45 \times P^{(2)} - M^{(1)} - 0.3$		ns

- (1) M = ATCL\_CLK[x] period
- (2) P = ATCLK[x] period
- (3) x = 0 to 3

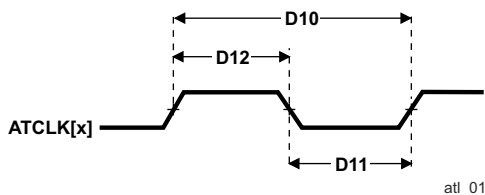

7-34. ATCLK[x] Timing

### 7.10.5.2 CPSW2G

For more details about features and additional description information on the device Gigabit Ethernet MAC, see the corresponding sections within [Signal Descriptions](#) and *Detailed Description*.

#### 7.10.5.2.1 CPSW2G MDIO Interface Timings

表 7-26 represents CPSW2G timing conditions.

表 7-26. CPSW2G MDIO Timing Conditions

PARAMETER	DESCRIPTION	MIN	MAX	UNIT
<b>INPUT CONDITIONS</b>				
SR <sub>I</sub>	Input signal slew rate	0.9	3.6	V/ns
<b>OUTPUT CONDITIONS</b>				
C <sub>L</sub>	Output load capacitance	10	470	pF

表 7-27, 表 7-28, and 图 7-35 present timing requirements for MDIO.

表 7-27. CPSW2G MDIO Timing Requirements

NO.	PARAMETER	DESCRIPTION	MIN	MAX	UNIT
MDIO1	t <sub>su(mdioV-mdcH)</sub>	Setup time, MDIO[x]_MDIO valid before MDIO[x]_MDC high	90		ns
MDIO2	t <sub>h(mdcH-mdioV)</sub>	Hold time, MDIO[x]_MDIO valid after MDIO[x]_MDC high	0		ns

表 7-28. CPSW2G MDIO Switching Characteristics

NO.	PARAMETER	DESCRIPTION	MIN	MAX	UNIT
MDIO3	t <sub>c(mdc)</sub>	Cycle time, MDIO[x]_MDC	400		ns
MDIO4	t <sub>w(mdcH)</sub>	Pulse Duration, MDIO[x]_MDC high	160		ns
MDIO5	t <sub>w(mdcL)</sub>	Pulse Duration, MDIO[x]_MDC low	160		ns
MDIO7	t <sub>d(mdcL-mdioV)</sub>	Delay time, MDIO[x]_MDC low to MDIO[x]_MDIO valid	-150	150	ns



图 7-35. CPSW2G MDIO Timing Requirements and Switching Characteristics

注

x = 0 in MCU domain

### 7.10.5.2.2 CPSW2G RMII Timings

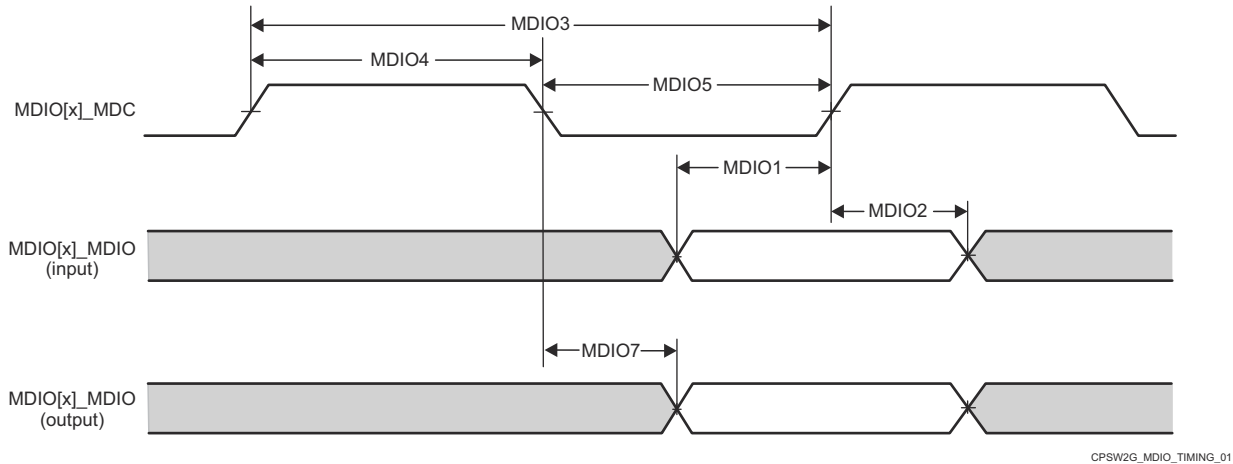
表 7-29, セクション 7.10.5.2.2.1, セクション 7.10.5.2.2.2, and セクション 7.10.5.2.2.3 present timing conditions, requirements, and switching characteristics for CPSW2G RMII.

**表 7-29. CPSW2G RMII Timing Conditions**

PARAMETER		MIN	MAX	UNIT	
<b>INPUT CONDITIONS</b>					
SR <sub>I</sub>	Input signal slew rate	VDD <sup>(1)</sup> = 1.8 V	0.108	0.54	V/ns
		VDD <sup>(1)</sup> = 3.3 V	0.4	1.2	V/ns
<b>OUTPUT CONDITIONS</b>					
C <sub>L</sub>	Output load capacitance	3	25	pF	

(1) VDD stands for corresponding power supply. For more information on the power supply name and the corresponding ball(s), see POWER column of the [Pin Attributes](#)

#### 7.10.5.2.2.1 CPSW2G RMII[x]\_REF\_CLK Timing Requirements – RMII Mode

see [図 7-36](#)

NO.		MIN	MAX	UNIT	
RMII1	t <sub>c(ref_clk)</sub>	Cycle time, RMII[x]_REF_CLK	19.999	20	ns
RMII2	t <sub>w(ref_clkH)</sub>	Pulse Duration, RMII[x]_REF_CLK high	7	13	ns
RMII3	t <sub>w(ref_clkL)</sub>	Pulse Duration, RMII[x]_REF_CLK low	7	13	ns

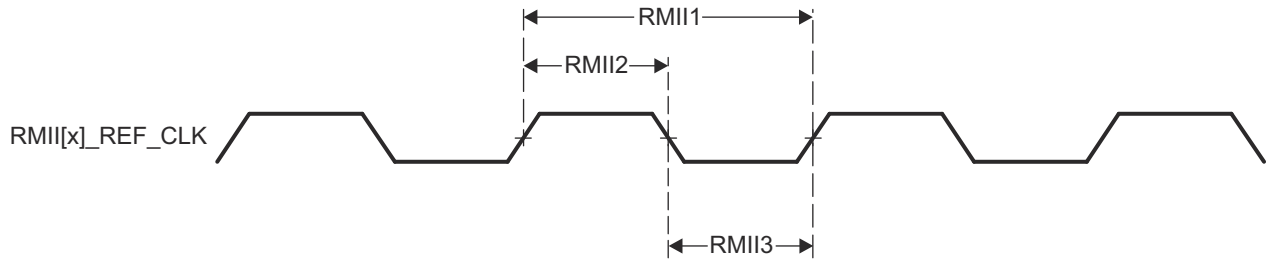

A. x = 1 in MCU domain.

**図 7-36. CPSW2G RMII[x]\_REFCLK Timing Requirements – RMII Mode**

#### 7.10.5.2.2.2 CPSW2G RMII[x]\_RXD[1:0], RMII[x]\_CRS\_DV, and RMII[x]\_RX\_ER Timing Requirements – RMII Mode

NO.		MIN	MAX	UNIT
RMII4	t <sub>su(rxdV-ref_clkH)</sub>	Setup time, RMII[x]_RXD[1:0] valid before RMII[x]_REF_CLK rising edge	4	ns
	t <sub>su(crs_dvV-ref_clkH)</sub>	Setup time, RMII[x]_CRS_DV valid before RMII[x]_REF_CLK rising edge	4	ns
	t <sub>su(rx_erV-ref_clkH)</sub>	Setup time, RMII[x]_RX_ER valid before RMII[x]_REF_CLK rising edge	4	ns
RMII5	t <sub>h(ref_clkH-rxdV)</sub>	Hold time, RMII[x]_RXD[1:0] valid after RMII[x]_REF_CLK rising edge	2	ns
	t <sub>h(ref_clkH-crs_dvV)</sub>	Hold time, RMII[x]_CRS_DV valid after RMII[x]_REF_CLK rising edge	2	ns
	t <sub>h(ref_clkH-rx_erV)</sub>	Hold time, RMII[x]_RX_ER valid after RMII[x]_REF_CLK rising edge	2	ns



図 7-37. CPSW2G RMII[x]\_RXD[1:0], RMII[x]\_CRS\_DV, RMII[x]\_RX\_ER Timing Requirements – RMII Mode

セクション 7.10.5.2.2.3, and 図 7-38 present switching characteristics for CPSW2G RMII Transmit.

#### 7.10.5.2.2.3 CPSW2G RMII[x]\_TXD[1:0], and RMII[x]\_TX\_EN Switching Characteristics – RMII Mode

see 図 7-38

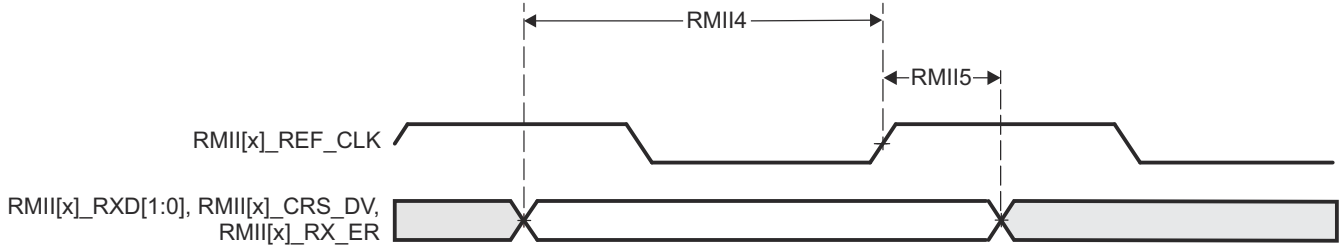
NO.	PARAMETER		MIN	MAX	UNIT
RMII6	$t_{d(\text{ref\_clkH-txdV})}$	Delay time, RMII[x]_REF_CLK rising edge to RMII[x]_TXD[1:0] valid	2	10	ns
	$t_{d(\text{ref\_clkH-tx\_enV})}$	Delay time, RMII[x]_REF_CLK rising edge to RMII[x]_TX_EN valid	2	10	ns



図 7-38. RMII[x]\_TXD[1:0], and RMII[x]\_TX\_EN Switching Characteristics – RMII Mode

#### 7.10.5.2.3 CPSW2G RGMII Timings

セクション 7.10.5.2.3.1, セクション 7.10.5.2.3.2, and 図 7-40 present timing requirements for receive RGMII operation.

For more information, see *Gigabit Ethernet MAC (MCU\_CPSW0)* section in *Peripherals* chapter in the device TRM.

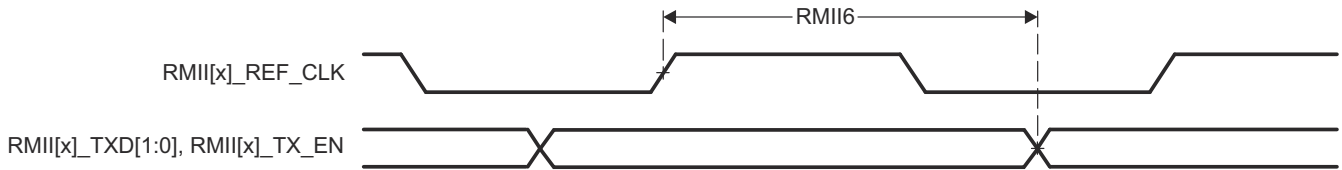
表 7-30. CPSW2G RGMII Timing Conditions

PARAMETER			MIN	MAX	UNIT
<b>INPUT CONDITIONS</b>					
SR <sub>I</sub>	Input slew rate	VDD <sup>(1)</sup> = 1.8 V	1.44	5	V/ns
		VDD <sup>(1)</sup> = 3.3 V	2.64	5	V/ns
<b>OUTPUT CONDITIONS</b>					
C <sub>L</sub>	Output load capacitance		2	20	pF
<b>PCB CONNECTIVITY REQUIREMENTS</b>					
$t_d$ (Trace Mismatch Delay)	Propagation delay mismatch across all traces	RGMII[x]_RXC, RGMII[x]_RD[3:0], RGMII[x]_RX_CTL		50	ps
		RGMII[x]_TXC, RGMII[x]_TD[3:0], RGMII[x]_TX_CTL		50	ps

(1) VDD stands for corresponding power supply. For more information on the power supply name and the corresponding ball(s), see POWER column of the Pin Attributes.

**7.10.5.2.3.1 RGMII[x]\_RXC Timing Requirements – RGMII Mode**

see [7-39](#)

NO.			MODE	MIN	MAX	UNIT
RGMII1	$t_{c(rx_c)}$	Cycle time, RGMII[x]_RXC	10Mbps	360	440	ns
			100Mbps	36	44	ns
			1000Mbps	7.2	8.8	ns
RGMII2	$t_{w(rx_cH)}$	Pulse duration, RGMII[x]_RXC high	10Mbps	160	240	ns
			100Mbps	16	24	ns
			1000Mbps	3.6	4.4	ns
RGMII3	$t_{w(rx_cL)}$	Pulse duration, RGMII[x]_RXC low	10Mbps	160	240	ns
			100Mbps	16	24	ns
			1000Mbps	3.6	4.4	ns

**7.10.5.2.3.2 CPSW2G Timing Requirements for RGMII[x]\_RD[3:0], and RGMII[x]\_RCTL – RGMII Mode**

see [7-39](#)

NO.			MODE	MIN	MAX	UNIT
RGMII4	$t_{su(rdV-rxcV)}$	Setup time, RGMII[x]_RD[3:0] valid before RGMII[x]_RXC transition	10Mbps	1		ns
			100Mbps	1		ns
			1000Mbps	1		ns
	$t_{su(rx_ctlV-rxcV)}$	Setup time, RGMII[x]_RX_CTL valid before RGMII[x]_RXC transition	10Mbps	1		ns
			100Mbps	1		ns
			1000Mbps	1		ns
RGMII5	$t_{h(rx_cV-rdV)}$	Hold time, RGMII[x]_RD[3:0] valid after RGMII[x]_RXC transition	10Mbps	1		ns
			100Mbps	1		ns
			1000Mbps	1		ns
	$t_{h(rx_cV-rx_ctlV)}$	Hold time, RGMII[x]_RX_CTL valid after RGMII[x]_RXC transition	10Mbps	1		ns
			100Mbps	1		ns
			1000Mbps	1		ns

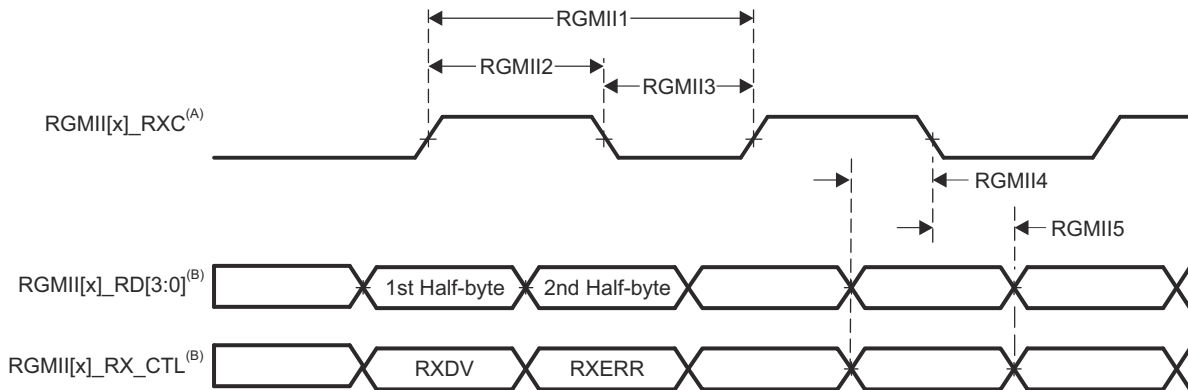

- A. RGMII\_RXC must be externally delayed relative to the data and control pins.
- B. Data and control information is received using both edges of the clocks. RGMII\_RXD[3:0] carries data bits 3-0 on the rising edge of RGMII\_RXC and data bits 7-4 on the falling edge of RGMII\_RXC. Similarly, RGMII\_RXCTL carries RXDV on rising edge of RGMII\_RXC and RXERR on falling edge of RGMII\_RXC.

**7-39. CPSW2G Receive Interface Timing, RGMII Operation**

セクション 7.10.5.2.3.3, セクション 7.10.5.2.3.4 present switching characteristics for transmit - RGMII for 10 Mbps, 100 Mbps, and 1000 Mbps.



7.10.5.2.3.3 CPSW2G RGMII[x]\_TXC Switching Characteristics – RGMII Mode

NO.	PARAMETER		MODE	MIN	MAX	UNIT
RGMII6	$t_{c(tc)}$	Cycle time, RGMII[x]_TXC	10Mbps	360	440	ns
			100Mbps	36	44	ns
			1000Mbps	7.2	8.8	ns
RGMII7	$t_{w(tcH)}$	Pulse duration, RGMII[x]_TXC high	10Mbps	160	240	ns
			100Mbps	16	24	ns
			1000Mbps	3.6	4.4	ns
RGMII8	$t_{w(tcL)}$	Pulse duration, RGMII[x]_TXC low	10Mbps	160	240	ns
			100Mbps	16	24	ns
			1000Mbps	3.6	4.4	ns

7.10.5.2.3.4 RGMII[x]\_TD[3:0], and RGMII[x]\_TX\_CTL Switching Characteristics – RGMII Mode

see 7-40

NO.	PARAMETER		MODE	MIN	MAX	UNIT
RGMII9	$t_{osu(tdV-txcV)}$	Output setup time, RGMII[x]_TD[3:0] valid to RGMII[x]_TXC transition	10Mbps	1.2		ns
			100Mbps	1.2		ns
			1000Mbps	1.2		ns
	$t_{osu(tx_ctlV-txcV)}$	Output setup time, RGMII[x]_TX_CTL valid to RGMII[x]_TXC transition	10Mbps	1.2		ns
			100Mbps	1.2		ns
			1000Mbps	1.2		ns
RGMII10	$t_{oh(tdV-txcV)}$	Output hold time, RGMII[x]_TD[3:0] valid after RGMII[x]_TXC transition	10Mbps	1.2		ns
			100Mbps	1.2		ns
			1000Mbps	1.2		ns
	$t_{oh(tx_ctlV-txcV)}$	Output hold time, RGMII[x]_TX_CTL valid after RGMII[x]_TXC transition	10Mbps	1.2		ns
			100Mbps	1.2		ns
			1000Mbps	1.2		ns

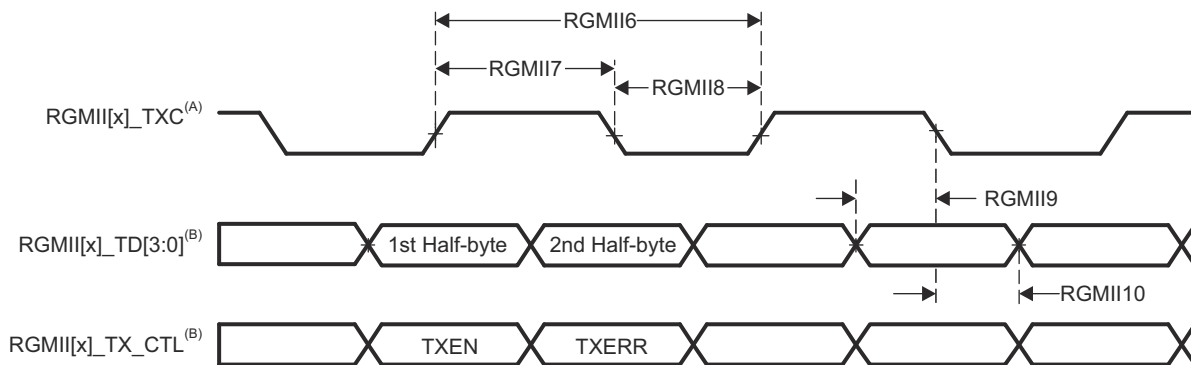

- A. TXC is delayed internally before being driven to the RGMII[x]\_TXC pin. This internal delay is always enabled.
- B. Data and control information is received using both edges of the clocks. RGMII\_TD[3:0] carries data bits 3-0 on the rising edge of RGMII\_TXC and data bits 7-4 on the falling edge of RGMII\_TXC. Similarly, RGMII\_TX\_CTL carries TXDV on rising edge of RGMII\_TXC and RTXERR on falling edge of RGMII\_TXC.

7-40. CPSW2G Transmit Interface Timing RGMII Mode

### 7.10.5.3 CSI-2

注

For more information, see the Camera Streaming Interface Receiver (CSI\_RX\_IF) chapter in the device TRM.

The CSI\_RX\_IF deals with the processing of the pixel data coming from an external image sensor and data from memory. It is a key component for the following multimedia applications: camera viewfinder, video record, and still image capture.

The CSI\_RX\_IF has a primary serial interface (CSI-2 port) compliant with the MIPI D-PHY RX specification v1.2 and the MIPI CSI-2 specification v1.3, with 4 differential data lanes plus 1 differential clock lane in synchronous mode, double data rate. Refer to the specification for timing details.

- 2.5 Gbps (1.25 GHz) for each lane.

### 7.10.5.4 DDRSS

For more details about features and additional description information on the device LPDDR4 Memory Interfaces, see the corresponding sections within [Signal Descriptions](#) and *Detailed Description*.

The device has dedicated interface to LPDDR4. It supports JEDEC JESD209-4B standard compliant LPDDR4 SDRAM devices with the following features:

- 32-bit data path to external SDRAM memory
- Memory device capacity: Up to 8GB address space available over two chip selects (4GB per rank)
- No support for byte mode LPDDR4 memories, or memories with more than 17 row address bits

表 7-31 and 图 7-41 present switching characteristics for DDRSS.

表 7-31. Switching Characteristics for DDRSS

NO.	PARAMETER	DDR TYPE	MIN	MAX	UNIT
1	$t_{c(DDR\_CKP/DDR\_CKN)}$ Cycle time, DDR0_CKP and DDR0_CKN	LPDDR4	0.4681	3.003	ns

1. Maximum DDR Frequency will be limited based on the specific memory type (vendor) used in a system and by PCB implementation. TI strongly recommends all designs to follow the TI LPDDR4 EVM PCB layout exactly in every detail (routing, spacing, vias/backdrill, PCB material, etc.) in order to achieve the full specified clock frequency. Refer to the Jacinto 7 DDR Board Design and Layout Guidelines for details.



图 7-41. DDRSS Memory Interface Clock Timing

For more information, see *DDR Subsystem (DDRSS)* section in *Memory Controllers* chapter in the device TRM.

### 7.10.5.5 DSS

For more details about features and additional description information on the device Display Subsystem – Video Output Ports, see the corresponding sections within [Signal Descriptions](#) and *Detailed Description*.

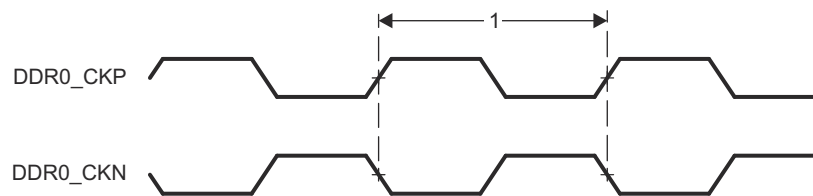
表 7-32 represents DPI timing conditions.

表 7-32. DPI Timing Conditions

PARAMETER	MIN	MAX	UNIT
INPUT CONDITIONS			

表 7-32. DPI Timing Conditions (continued)

PARAMETER		MIN	MAX	UNIT
SR <sub>I</sub>	Input slew rate	1.44	26.4	V/ns
<b>OUTPUT CONDITIONS</b>				
C <sub>L</sub>	Output load capacitance	1.5	5	pF
<b>PCB CONNECTIVITY REQUIREMENTS</b>				
t <sub>d</sub> (Trace Mismatch Delay)	Propagation delay mismatch across all traces		100	ps

表 7-33, 表 7-34, 图 7-42 和 图 7-43 assume testing over the recommended operating conditions and electrical characteristic conditions.

表 7-33. DPI Video Output Switching Characteristics

NO.(2)	PARAMETER		MIN	MAX	UNIT
D1	t <sub>c</sub> (pclk)	Cycle time, VOUT(x)_PCLK	6.06		ns
D2	t <sub>w</sub> (pclkL)	Pulse duration, VOUT(x)_PCLK low	0.475×P(1)		ns
D3	t <sub>w</sub> (pclkH)	Pulse duration, VOUT(x)_PCLK high	0.475×P(1)		ns
D4	t <sub>d</sub> (pclkV-dataV)	Delay time, VOUT(x)_PCLK transition to VOUT(x)_DATA[23:0] transition	-0.68	1.78	ns
D5	t <sub>d</sub> (pclkV-ctrlL)	Delay time, VOUT(x)_PCLK transition to control signals VOUT(x)_VSYNC, VOUT(x)_HSYNC, VOUT(x)_DE falling edge	-0.68	1.78	ns

(1) P = output VOUT(x)\_PCLK period in ns.

(2) x in VOUT(x) = 1 or 2

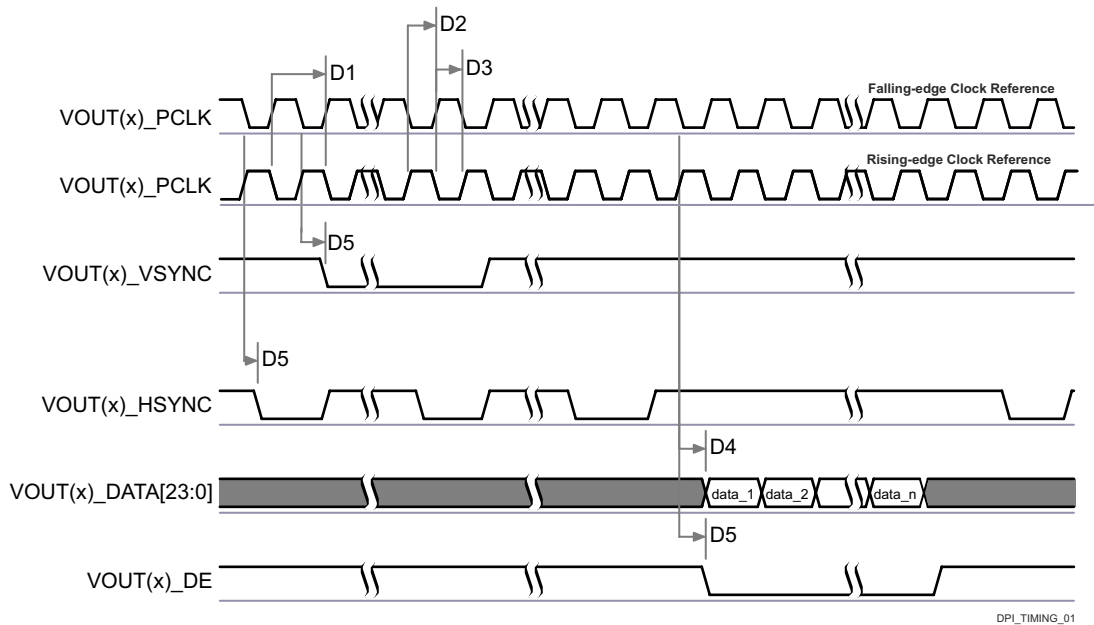

- A. The configuration of assertion of the data can be programmed on the falling or rising edge of the pixel clock.
- B. The polarity and the pulse width of VOUT(x)\_HSYNC and VOUT(x)\_VSYNC are programmable, refer to *Display Subsystem (DSS)* section in *Peripherals* chapter in the device TRM.
- C. The VOUT(x)\_PCLK frequency can be configured, refer to *Display Subsystem* section in *Peripherals* chapter in the device TRM.
- D. x in VOUT(x) = 1 or 2.

图 7-42. DPI Video Output

表 7-34. DPI External Pixel Clock Timing Requirements

NO. (2)			MIN	MAX	UNIT
D6	$t_{c(\text{extpclk})}$	Cycle time, VOUT(x)_EXTPCLKIN	6.06		ns
D7	$t_{w(\text{extpclkL})}$	Pulse duration, VOUT(x)_EXTPCLKIN low	$0.45 \times P^{(1)}$		ns
D8	$t_{w(\text{extpclkH})}$	Pulse duration, VOUT(x)_EXTPCLKIN high	$0.45 \times P^{(1)}$		ns

(1) P = output VOUT(x)\_PCLK period in ns.  
 (2) x in VOUT(x) = 1 or 2



図 7-43. DPI External Pixel Clock Input

For more information, see *Display Subsystem (DSS) and Peripherals* section in *Peripherals* chapter in the device TRM.

### 7.10.5.6 eCAP

The supported features by the device ECAP are:

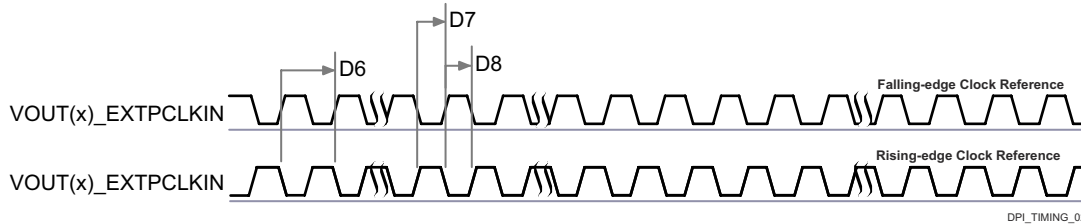
- 32-bit time base counter
- 4-event time-stamp registers (each 32 bits)
- Independent edge polarity selection for up to four sequenced time-stamp capture events
- Interrupt capabilities on any of the four capture events
- Input capture signal pre-scaling (from 1 to 16)
- Support of different capture modes (single shot capture, continuous mode capture, absolute timestamp capture or difference mode time-stamp capture)

表 7-35 represents ECAP timing conditions.

表 7-35. ECAP Timing Conditions

PARAMETER		MIN	MAX	UNIT
<b>INPUT CONDITIONS</b>				
SR <sub>i</sub>	Input slew rate	1	4	V/ns
<b>OUTPUT CONDITIONS</b>				
C <sub>L</sub>	Output load capacitance	2	7	pF

セクション 7.10.5.6.1 and セクション 7.10.5.6.2 present timing and switching characteristics for eCAP (see 図 7-44 and 図 7-45).

### 7.10.5.6.1 Timing Requirements for eCAP

NO.	PARAMETER	DESCRIPTION	MIN	MAX	UNIT
CAP1	$t_{w(\text{cap})}$	Pulse duration, CAP (asynchronous)	$2 + 2P^{(1)}$		ns

(1) P = sysclk



図 7-44. eCAP Input Timings

### 7.10.5.6.2 Switching Characteristics for eCAP

NO.	PARAMETER	DESCRIPTION	MIN	MAX	UNIT
CAP2	$t_{w(\text{apwm})}$	Pulse duration, APWM	$-2 + 2P^{(1)}$		ns

(1) P = sysclk



図 7-45. eCAP Output Timings

For more information, see *Enhanced Capture (ECAP) Module* section in *Peripherals* chapter in the device TRM.

### 7.10.5.7 EPWM

The supported features by the device EPWM are:

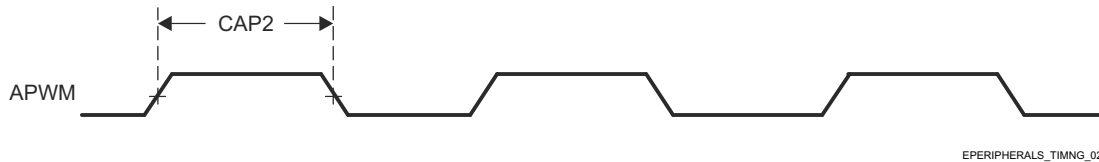
- Dedicated 16-bit time-base counter with period and frequency control
- Two independent PWM outputs which can be used in different configurations (with single-edge operation, with dual-edge symmetric operation or one independent PWM output with dual-edge asymmetric operation)
- Asynchronous override control of PWM signals during fault conditions
- Programmable phase-control support for lag or lead operation relative to other EPWM modules
- Dead-band generation with independent rising and falling edge delay control
- Programmable trip zone allocation of both latched and un-latched fault conditions
- Events enabling to trigger both CPU interrupts and start of ADC conversions

表 7-36 represents EPWM timing conditions.

表 7-36. EPWM Timing Conditions

PARAMETER	DESCRIPTION	MIN	MAX	UNIT
<b>INPUT CONDITIONS</b>				
$SR_i$	Input slew rate	1	4	V/ns
<b>OUTPUT CONDITIONS</b>				
$C_L$	Output load capacitance	2	7	pF

セクション 7.10.5.7.2, セクション 7.10.5.7.1 and present timing and switching characteristics for eHRPWM (see 図 7-47, 図 7-48, 図 7-49, and 図 7-46).

**7.10.5.7.1 Timing Requirements for eHRPWM**

NO.	PARAMETER	DESCRIPTION	MIN	MAX	UNIT
PWM6	$t_{w(\text{synci})}$	Pulse duration, EHRPWM_SYNCI	2 + 2P <sup>(1)</sup>		ns
PWM7	$t_{w(\text{tz})}$	Pulse duration, EHRPWM_TZn_IN low	2 + 3P <sup>(1)</sup>		ns

(1) P = sysclk

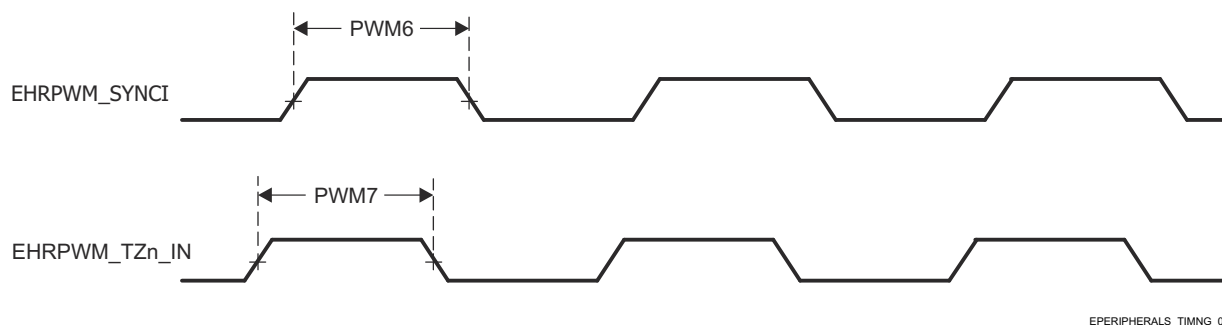

EPERIPHERALS\_TIMNG\_07

**7-46. ePWM\_SYNCI and ePWM\_TZn\_IN Output Timings**

 For more information, see *Camera Subsystem* section in *Peripherals* chapter in the device TRM.

**7.10.5.7.2 Switching Characteristics for eHRPWM**

NO.	PARAMETER	DESCRIPTION	MIN	MAX	UNIT
PWM1	$t_{w(\text{pwm})}$	Pulse duration, EHRPWM_A/B, high or low	P-3 <sup>(1)</sup>		ns
PWM2	$t_{w(\text{syncout})}$	Pulse duration, EHRPWM_SYNCO	P-3 <sup>(1)</sup>		ns
PWM3	$t_{d(\text{tzL-pwmV})}$	Delay time, EHRPWM_TZn_IN falling edge to EHRPWM_A/B valid		11	ns
PWM4	$t_{d(\text{tzL-pwmZ})}$	Delay time, EHRPWM_TZn_IN falling edge to EHRPWM_A/B Hi-Z		11	ns

NO.	PARAMETER	DESCRIPTION	MIN	MAX	UNIT
PWM5	$t_{w(soc)}$	Pulse duration, EHRPWM_SOC A/B	P-3 <sup>(1)</sup>		ns

(1) P = sysclk

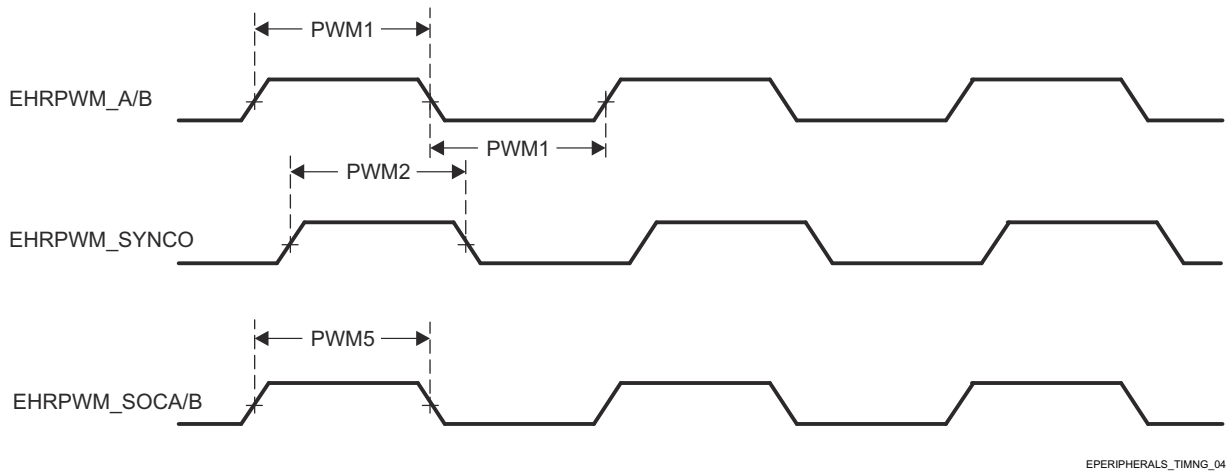

7-47. EPWM\_A/B\_out, ePWM\_SYNCO, and ePWM\_SOC A/B Input Timings

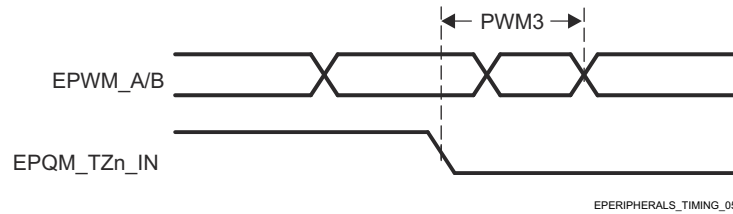

7-48. EPWM\_A/B and ePWM\_TZn\_IN Forced High/Low Input Timings

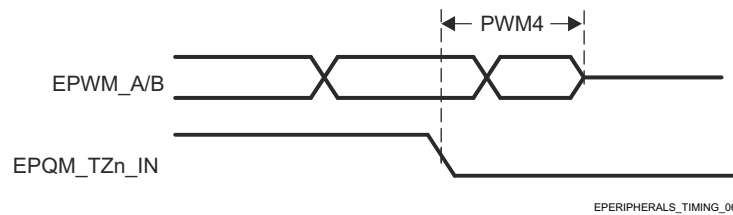

7-49. EPWM\_A/B and ePWM\_TZn\_IN Hi-Z Input Timings

### 7.10.5.8 eQEP

The supported features by the device eQEP are:

- Input Synchronization
- Three Stage/Six Stage Digital Noise Filter
- Quadrature Decoder Unit
- Position Counter and Control unit for position measurement
- Quadrature Edge Capture unit for low speed measurement
- Unit Time base for speed/frequency measurement
- Watchdog Timer for detecting stalls

表 7-37 represents EQEP timing conditions.

表 7-37. EQEP Timing Conditions

PARAMETER		MIN	MAX	UNIT
<b>INPUT CONDITIONS</b>				
SR <sub>I</sub>	Input slew rate	1	4	V/ns
<b>OUTPUT CONDITIONS</b>				
C <sub>L</sub>	Output load capacitance	2	7	pF

セクション 7.10.5.8.1 and セクション 7.10.5.8.2 present timing requirements and switching characteristics for eQEP (see 図 7-50).

### 7.10.5.8.1 Timing Requirements for eQEP

NO.	PARAMETER	MIN	MAX	UNIT
QEP1	t <sub>w(qep)</sub> Pulse duration, QEP_A/B	2 + 2P <sup>(1)</sup>		ns
QEP2	t <sub>w(qepiH)</sub> Pulse duration, QEP_I high	2 + 2P <sup>(1)</sup>		ns
QEP3	t <sub>w(qepiL)</sub> Pulse duration, QEP_I low	2 + 2P <sup>(1)</sup>		ns
QEP4	t <sub>w(qepsH)</sub> Pulse duration, QEP_S high	2 + 2P <sup>(1)</sup>		ns
QEP5	t <sub>w(qepsL)</sub> Pulse duration, QEP_S low	2 + 2P <sup>(1)</sup>		ns

(1) P = sysclk



図 7-50. eQEP Input Timings

### 7.10.5.8.2 Switching Characteristics for eQEP

NO.	PARAMETER	MIN	MAX	UNIT
QEP6	t <sub>d(QEP-CNTR)</sub> Delay time, external clock to counter increment		24	ns

For more information, see *Enhanced Quadrature Encoder Pulse (EQEP) Module* section in *Peripherals* chapter in the device TRM.

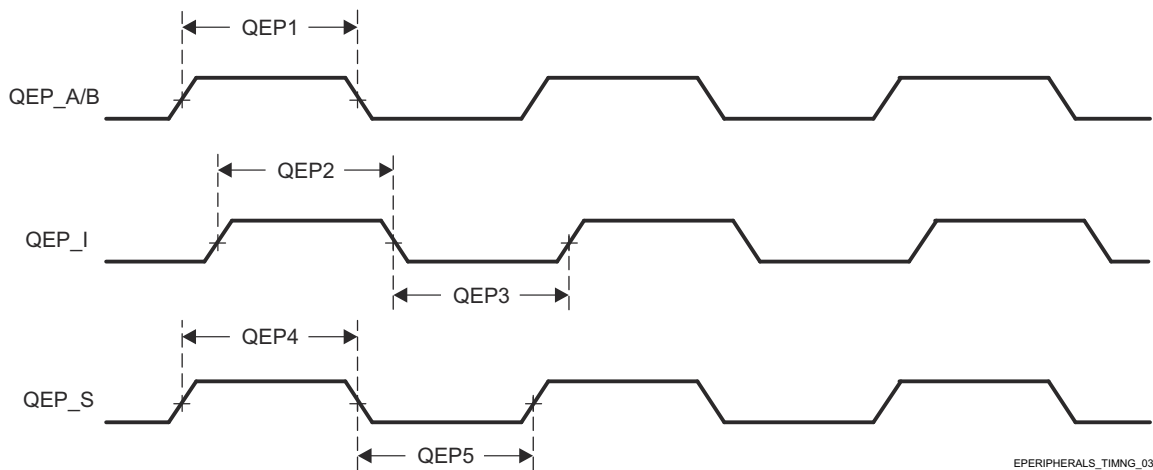
### 7.10.5.9 GPIO

The device has ten instances of GPIO modules. The GPIO modules are integrated in three groups.

- Group one: WKUP\_GPIO0 and WKUP\_GPIO1
- Group two: GPIO0, GPIO2, GPIO4, and GPIO6
- Group three: GPIO1, GPIO3, GPIO5, and GPIO7

Within each group, exactly one module is selected to control the corresponding I/O pins and pin interrupts.



The GPIO pins are grouped into banks (16 pins per bank), which means that each GPIO module provides up to 144 dedicated general-purpose pins with input and output capabilities; thus, the general-purpose interface supports up to 432 (3 instances × (9 banks × 16 pins)) pins. Since WKUP\_GPIOu\_[84:143] (u = 0, 1), GPIO\_n\_[128:143] (n = 0, 2, 4, 6), and GPIO\_m\_[36:143] (m = 1, 3, 5, 7) are reserved in this device, general purpose interface supports up to 248 I/O pins.

For more details about features and additional description information on the device General-Purpose Interface, see the corresponding sections within [Signal Descriptions](#) and *Detailed Description*.

注

The general-purpose input/output i (i = 0 to 1) is also referred to as GPIOi.

表 7-38, セクション 7.10.5.9.1, and セクション 7.10.5.9.2 present timing conditions, requirements, and switching characteristics for GPIO.

表 7-38. GPIO Timing Conditions

PARAMETER		BUFFER TYPE	MIN	MAX	UNIT
<b>INPUT CONDITIONS</b>					
SR <sub>i</sub>	Input slew rate	LVC MOS	0.2	6.6	V/ns
		I2C OD FS	0.2	0.8	V/ns
<b>OUTPUT CONDITIONS</b>					
C <sub>L</sub>	Output load capacitance	LVC MOS	3	10	pF
		I2C OD FS	3	100	pF

7.10.5.9.1 GPIO Timing Requirements

NO.	PARAMETER		BUFFER TYPE	MIN	MAX	UNIT
GPIO1	t <sub>w(gpio_in)</sub>	Pulse width, GPIO <sub>n</sub> _x	1.8 V	2P + 2.6 <sup>(1)</sup>		ns
			3.3 V	2P + 3.4 <sup>(1)</sup>		ns

(1) P = functional clock period in ns.

7.10.5.9.2 GPIO Switching Characteristics

NO.	PARAMETER		BUFFER TYPE	MIN	MAX	UNIT
GPIO3	t <sub>w(GPIO_OUT)</sub>	Minimum Output Pulse Width	LVC MOS	-3.6 + 0.975P <sup>(1)</sup>		ns
GPIO4	t <sub>w(GPIO_OUT)</sub>	Minimum Output Pulse Width Low	I2C Open Drain	160		ns
GPIO5	t <sub>w(GPIO_OUT)</sub>	Minimum Output Pulse Width High	I2C Open Drain	60		ns

(1) P = functional clock period in ns.

For more information, see *General-Purpose Interface (GPIO)* section in *Peripherals* chapter in the device TRM.

7.10.5.10 GPMC

For more details about features and additional description information on the device General-Purpose Memory Controller, see the corresponding sections within [Signal Descriptions](#) and *Detailed Description*.

表 7-39 represents GPMC timing conditions.

注

The IO timings provided in this section are applicable for all combinations of signals for GPMC0. However, the timings are only valid for GPMC0 if signals within a single IOSET are used. The IOSETs are defined in the [GPMC0\\_IOSET](#), [GPMC0\\_IOSET](#) table.

表 7-39. GPMC Timing Conditions

PARAMETER	DESCRIPTION	MIN	MAX	UNIT	
<b>Input Conditions</b>					
SR <sub>i</sub>	Input slew rate	1.65	4	V/ns	
<b>Output Conditions</b>					
C <sub>L</sub>	Output load capacitance	5	20	pF	
<b>PCB Connectivity Requirements</b>					
t <sub>d</sub> (Trace Delay)	Propagation delay of each trace	133 MHz Synchronous Mode	140	360	ps
		All other modes	140	720	
t <sub>d</sub> (Trace Mismatch Delay)	Propagation mismatch across all traces		200	ps	

7.10.5.10.1 GPMC and NOR Flash — Synchronous Mode

セクション 7.10.5.10.1.1 和 セクション 7.10.5.10.1.2 assume testing over the recommended operating conditions and electrical characteristic conditions below (see 図 7-51 through 図 7-55).

7.10.5.10.1.1 GPMC and NOR Flash Timing Requirements — Synchronous Mode

NO.	PARAMETER	DESCRIPTION <sup>(2)</sup>	MODE <sup>(3)</sup>	MIN	MAX	MIN	MAX	UNIT
				100 MHz <sup>(4)</sup>		133 MHz <sup>(4)</sup>		
F12	t <sub>su</sub> (dV-clkH)	Setup time, input data GPMC_AD[15:0] valid before output clock GPMC_CLK high	div_by_1_mode; GPMC_FCLK_MUX; TIMEPARAGRANULARITY_X1	1.81		1.11		ns
			not_div_by_1_mode; GPMC_FCLK_MUX; TIMEPARAGRANULARITY_X1	1.06				ns
F13	t <sub>h</sub> (clkH-dV)	Hold time, input data GPMC_AD[15:0] valid after output clock GPMC_CLK high	div_by_1_mode; GPMC_FCLK_MUX; TIMEPARAGRANULARITY_X1	1.78		2.28		ns
			not_div_by_1_mode; GPMC_FCLK_MUX; TIMEPARAGRANULARITY_X1	1.78				ns
F21	t <sub>su</sub> (waitV-clkH)	Setup time, input wait GPMC_WAIT[j] valid before output clock GPMC_CLK high <sup>(1)</sup>	div_by_1_mode; GPMC_FCLK_MUX; TIMEPARAGRANULARITY_X1	1.81		1.11		ns
			not_div_by_1_mode; GPMC_FCLK_MUX; TIMEPARAGRANULARITY_X1	1.06				ns
F22	t <sub>h</sub> (clkH-waitV)	Hold time, input wait GPMC_WAIT[j] valid after output clock GPMC_CLK high <sup>(1)</sup>	div_by_1_mode; GPMC_FCLK_MUX; TIMEPARAGRANULARITY_X1	1.78		2.28		ns
			not_div_by_1_mode; GPMC_FCLK_MUX; TIMEPARAGRANULARITY_X1	1.78				ns

(1) In GPMC\_WAIT[j], j is equal to 0, 1, 2, or 3.

(2) Wait monitoring support is limited to a WaitMonitoringTime value > 0. For a full description of wait monitoring feature, see *General-Purpose Memory Controller (GPMC)* section in the device TRM.

(3) For div\_by\_1\_mode:

- GPMC\_CONFIG1\_i Register: GPMCFCLKDIVIDER = 0h:
  - GPMC\_CLK frequency = GPMC\_FCLK frequency
- GPMC\_CONFIG1\_i Register: GPMCFCLKDIVIDER = 1h to 3h:
  - GPMC\_CLK frequency = GPMC\_FCLK frequency / (2 to 4)
- CTRLMMR\_GPMC\_CLKSEL[1-0] CLK\_SEL = 01 = PER1\_PLL\_CLKOUT / 3 = 300 / 3 = 100 MHz

- For TIMEPARAGRANULARITY\_X1:
  - GPMC\_CONFIG1\_i Register: TIMEPARAGRANULARITY = 0h = x1 latencies (affecting RD/WRCYCLETIME, RD/WRACCESTIME, PAGEBURSTACCESTIME, CSONTIME, CSRD/WROFFTIME, ADVONTIME, ADVRD/WROFFTIME, OEONTIME, OEOFFTIME, WEONTIME, WEOFFTIME, CYCLE2CYCLEDELAY, BUSTURNAROUND, TIMEOUTSTARTVALUE, WRDATAONADMUXBUS)
- (4) For 100 MHz:
  - CTRLMMR\_GPMC\_CLKSEL[1-0] CLK\_SEL = 01 = MAIN\_PLL2\_HSDIV1\_CLKOUT / 3
- For 133 MHz:
  - CTRLMMR\_GPMC\_CLKSEL[1-0] CLK\_SEL = 00 = MAIN\_PLL0\_HSDIV3\_CLKOUT

**7.10.5.10.1.2 GPMC and NOR Flash Switching Characteristics – Synchronous Mode**

NO. <sup>(2)</sup>	PARAMETER	DESCRIPTION	MODE <sup>(19)</sup>	MIN	MAX	MIN	MAX	UNI T
				100 MHz <sup>(20)</sup>		133 MHz <sup>(20)</sup>		
F0	tc(clk)	Period, output clock GPMC_CLK <sup>(18)</sup>	div_by_1_mode; ; GPMC_FCLK_MUX; TIMEPARAGRANULARITY_X1	10		7.52		ns
F1	t <sub>w</sub> (clkH)	Typical pulse duration, output clock GPMC_CLK high	div_by_1_mode; ; GPMC_FCLK_MUX; TIMEPARAGRANULARITY_X1	0.475*P <sup>(15)</sup> - 0.3		0.475*P <sup>(15)</sup> - 0.3		ns
F1	t <sub>w</sub> (clkL)	Typical pulse duration, output clock GPMC_CLK low	div_by_1_mode; ; GPMC_FCLK_MUX; TIMEPARAGRANULARITY_X1	0.475*P <sup>(15)</sup> - 0.3		0.475*P <sup>(15)</sup> - 0.3		ns
F2	t <sub>d</sub> (clkH-csnV)	Delay time, output clock GPMC_CLK rising edge to output chip select GPMC_CS[n] transition <sup>(14)</sup>	div_by_1_mode; ; GPMC_FCLK_MUX; TIMEPARAGRANULARITY_X1 no extra_delay	F <sup>(6)</sup> - 2.2	F+3.75	F <sup>(6)</sup> - 2.2	F <sup>(6)</sup> + 3.75	ns
F3	t <sub>d</sub> (clkH-CSn[i]V)	Delay time, output clock GPMC_CLK rising edge to output chip select GPMC_CS[n] invalid <sup>(14)</sup>	div_by_1_mode; ; GPMC_FCLK_MUX; TIMEPARAGRANULARITY_X1 no extra_delay	E <sup>(5)</sup> - 2.2	E <sup>(5)</sup> + 3.75	E <sup>(5)</sup> - 2.2	E <sup>(5)</sup> + 3.75	ns
F4	t <sub>d</sub> (aV-clk)	Delay time, output address GPMC_A[27:1] valid to output clock GPMC_CLK first edge	div_by_1_mode; ; GPMC_FCLK_MUX; TIMEPARAGRANULARITY_X1	B <sup>(2)</sup> -2.3	B <sup>(2)</sup> +4.5	B <sup>(2)</sup> -2.3	B <sup>(2)</sup> +4.5	ns
F5	t <sub>d</sub> (clkH-aIV)	Delay time, output clock GPMC_CLK rising edge to output address GPMC_A[27:1] invalid	div_by_1_mode; GPMC_FCLK_MUX; TIMEPARAGRANULARITY_X1	-2.3	4.5	-2.3	4.5	ns
F6	t <sub>d</sub> (be[x]nV-clk)	Delay time, output lower byte enable and command latch enable GPMC_BE0n_CLE, output upper byte enable GPMC_BE1n valid to output clock GPMC_CLK first edge	div_by_1_mode; ; GPMC_FCLK_MUX; TIMEPARAGRANULARITY_X1	B <sup>(2)</sup> -2.3	B <sup>(2)</sup> +1.9	B <sup>(2)</sup> -2.3	B <sup>(2)</sup> +1.9	ns
F7	t <sub>d</sub> (clkH-be[x]nIV)	Delay time, output clock GPMC_CLK rising edge to output lower byte enable and command latch enable GPMC_BE0n_CLE, output upper byte enable GPMC_BE1n invalid <sup>(11)</sup>	div_by_1_mode; ; GPMC_FCLK_MUX; TIMEPARAGRANULARITY_X1	D <sup>(4)</sup> -2.3	D <sup>(4)</sup> +1.9	D <sup>(4)</sup> -2.3	D <sup>(4)</sup> +1.9	ns
F7	t <sub>d</sub> (clkL-be[x]nIV)	Delay time, GPMC_CLK falling edge to GPMC_BE0n_CLE, GPMC_BE1n invalid <sup>(12)</sup>	div_by_1_mode; ; GPMC_FCLK_MUX; TIMEPARAGRANULARITY_X1	D <sup>(4)</sup> -2.3	D <sup>(4)</sup> +1.9	D <sup>(4)</sup> -2.3	D <sup>(4)</sup> +1.9	ns

NO. <sup>(2)</sup>	PARAMETER	DESCRIPTION	MODE <sup>(19)</sup>	MIN	MAX	MIN	MAX	UNI T
				100 MHz <sup>(20)</sup>		133 MHz <sup>(20)</sup>		
F7	$t_{d(\text{clkL-be}[x]nV)}$	Delay time, GPMC_CLK falling edge to GPMC_BE0n_CLE, GPMC_BE1n invalid <sup>(13)</sup>	div_by_1_mode ; GPMC_FCLK_MUX; TIMEPARAGRANULARITY_X1	D <sup>(4)</sup> -2.3	D <sup>(4)</sup> +1.9	D <sup>(4)</sup> -2.3	D <sup>(4)</sup> +1.9	ns
F8	$t_{d(\text{clkH-advn})}$	Delay time, output clock GPMC_CLK rising edge to output address valid and address latch enable GPMC_ADVn_ALE transition	div_by_1_mode ; GPMC_FCLK_MUX; TIMEPARAGRANULARITY_X1 no extra_delay	G <sup>(7)</sup> -2.3	G <sup>(7)</sup> +4.5	G <sup>(7)</sup> -2.3	G <sup>(7)</sup> +4.5	ns
F9	$t_{d(\text{clkH-advnIV})}$	Delay time, output clock GPMC_CLK rising edge to output address valid and address latch enable GPMC_ADVn_ALE invalid	div_by_1_mode; GPMC_FCLK_MUX; TIMEPARAGRANULARITY_X1 no extra_delay	D <sup>(4)</sup> -2.3	D <sup>(4)</sup> +4.5	D <sup>(4)</sup> -2.3	D <sup>(4)</sup> +4.5	ns
F10	$t_{d(\text{clkH-oen})}$	Delay time, output clock GPMC_CLK rising edge to output enable GPMC_OEn_REn transition	div_by_1_mode ; GPMC_FCLK_MUX; TIMEPARAGRANULARITY_X1 no extra_delay	H <sup>(8)</sup> -2.3	H <sup>(8)</sup> +3.5	H <sup>(8)</sup> -2.3	H <sup>(8)</sup> +3.5	ns
F11	$t_{d(\text{clkH-oenIV})}$	Delay time, output clock GPMC_CLK rising edge to output enable GPMC_OEn_REn invalid	div_by_1_mode ; GPMC_FCLK_MUX; TIMEPARAGRANULARITY_X1 no extra_delay	E <sup>(8)</sup> -2.3	E <sup>(8)</sup> +3.5	E <sup>(8)</sup> -2.3	E <sup>(8)</sup> +3.5	ns
F14	$t_{d(\text{clkH-wen})}$	Delay time, output clock GPMC_CLK rising edge to output write enable GPMC_WEn transition	div_by_1_mode ; GPMC_FCLK_MUX; TIMEPARAGRANULARITY_X1 no extra_delay	I <sup>(9)</sup> -2.3	I <sup>(9)</sup> +4.5	I <sup>(9)</sup> -2.3	I <sup>(9)</sup> +4.5	ns
F15	$t_{d(\text{clkH-do})}$	Delay time, output clock GPMC_CLK rising edge to output data GPMC_AD[15:0] transition <sup>(11)</sup>	div_by_1_mode ; GPMC_FCLK_MUX; TIMEPARAGRANULARITY_X1	J <sup>(10)</sup> -2.3	J <sup>(10)</sup> +2.7	J <sup>(10)</sup> -2.3	J <sup>(10)</sup> +2.7	ns
F15	$t_{d(\text{clkL-do})}$	Delay time, GPMC_CLK falling edge to GPMC_AD[15:0] data bus transition <sup>(12)</sup>	div_by_1_mode ; GPMC_FCLK_MUX; TIMEPARAGRANULARITY_X1	J <sup>(10)</sup> -2.3	J <sup>(10)</sup> +2.7	J <sup>(10)</sup> -2.3	J <sup>(10)</sup> +2.7	ns
F15	$t_{d(\text{clkL-do})}$	Delay time, GPMC_CLK falling edge to GPMC_AD[15:0] data bus transition <sup>(13)</sup>	div_by_1_mode ; GPMC_FCLK_MUX; TIMEPARAGRANULARITY_X1	J <sup>(10)</sup> -2.3	J <sup>(10)</sup> +2.7	J <sup>(10)</sup> -2.3	J <sup>(10)</sup> +2.7	ns
F17	$t_{d(\text{clkH-be}[x]n)}$	Delay time, output clock GPMC_CLK rising edge to output lower byte enable and command latch enable GPMC_BE0n_CLE transition <sup>(11)</sup>	div_by_1_mode ; GPMC_FCLK_MUX; TIMEPARAGRANULARITY_X1	J <sup>(10)</sup> -2.3	J <sup>(10)</sup> +1.9	J <sup>(10)</sup> -2.3	J <sup>(10)</sup> +1.9	ns
F17	$t_{d(\text{clkL-be}[x]n)}$	Delay time, GPMC_CLK falling edge to GPMC_BE0n_CLE, GPMC_BE1n transition <sup>(12)</sup>	div_by_1_mode ; GPMC_FCLK_MUX; TIMEPARAGRANULARITY_X1	J <sup>(10)</sup> -2.3	J <sup>(10)</sup> +1.9	J <sup>(10)</sup> -2.3	J <sup>(10)</sup> +1.9	ns
F17	$t_{d(\text{clkL-be}[x]n)}$	Delay time, GPMC_CLK falling edge to GPMC_BE0n_CLE, GPMC_BE1n transition <sup>(13)</sup>	div_by_1_mode ; GPMC_FCLK_MUX; TIMEPARAGRANULARITY_X1	J <sup>(10)</sup> -2.3	J <sup>(10)</sup> +1.9	J <sup>(10)</sup> -2.3	J <sup>(10)</sup> +1.9	ns
F18	$t_{w(\text{csnV})}$	Pulse duration, output chip select GPMC_CSn[i] low <sup>(14)</sup>	Read	A <sup>(1)</sup>		A <sup>(1)</sup>		ns
			Write	A <sup>(1)</sup>		A <sup>(1)</sup>		ns
F19	$t_{w(\text{be}[x]nV)}$	Pulse duration, output lower byte enable and command latch enable GPMC_BE0n_CLE, output upper byte enable GPMC_BE1n low	Read	C <sup>(3)</sup>		C <sup>(3)</sup>		ns
			Write	C <sup>(3)</sup>		C <sup>(3)</sup>		ns

NO.(2)	PARAMETER	DESCRIPTION	MODE(19)	MIN	MAX	MIN	MAX	UNIT
				100 MHz(20)		133 MHz(20)		
F20	t <sub>w(advnV)</sub>	Pulse duration, output address valid and address latch enable GPMC_ADVn_ALE low	Read	K <sup>(16)</sup>		K <sup>(16)</sup>		ns
			Write	K <sup>(16)</sup>		K <sup>(16)</sup>		ns

(1) For single read:  $A = (\text{CSRdOffTime} - \text{CSOnTime}) \times (\text{TimeParaGranularity} + 1) \times \text{GPMC\_FCLK}^{(17)}$   
 For burst read:  $A = (\text{CSRdOffTime} - \text{CSOnTime} + (n - 1) \times \text{PageBurstAccessTime}) \times (\text{TimeParaGranularity} + 1) \times \text{GPMC\_FCLK}^{(17)}$   
 For burst write:  $A = (\text{CSWrOffTime} - \text{CSOnTime} + (n - 1) \times \text{PageBurstAccessTime}) \times (\text{TimeParaGranularity} + 1) \times \text{GPMC\_FCLK}^{(17)}$   
 With n being the page burst access number.

(2)  $B = \text{ClkActivationTime} \times \text{GPMC\_FCLK}^{(17)}$

(3) For single read:  $C = \text{RdCycleTime} \times (\text{TimeParaGranularity} + 1) \times \text{GPMC\_FCLK}^{(17)}$   
 For burst read:  $C = (\text{RdCycleTime} + (n - 1) \times \text{PageBurstAccessTime}) \times (\text{TimeParaGranularity} + 1) \times \text{GPMC\_FCLK}^{(17)}$   
 For burst write:  $C = (\text{WrCycleTime} + (n - 1) \times \text{PageBurstAccessTime}) \times (\text{TimeParaGranularity} + 1) \times \text{GPMC\_FCLK}^{(17)}$   
 With n being the page burst access number.

(4) For single read:  $D = (\text{RdCycleTime} - \text{AccessTime}) \times (\text{TimeParaGranularity} + 1) \times \text{GPMC\_FCLK}^{(17)}$   
 For burst read:  $D = (\text{RdCycleTime} - \text{AccessTime}) \times (\text{TimeParaGranularity} + 1) \times \text{GPMC\_FCLK}^{(17)}$   
 For burst write:  $D = (\text{WrCycleTime} - \text{AccessTime}) \times (\text{TimeParaGranularity} + 1) \times \text{GPMC\_FCLK}^{(17)}$

(5) For single read:  $E = (\text{CSRdOffTime} - \text{AccessTime}) \times (\text{TimeParaGranularity} + 1) \times \text{GPMC\_FCLK}^{(17)}$   
 For burst read:  $E = (\text{CSRdOffTime} - \text{AccessTime}) \times (\text{TimeParaGranularity} + 1) \times \text{GPMC\_FCLK}^{(17)}$   
 For burst write:  $E = (\text{CSWrOffTime} - \text{AccessTime}) \times (\text{TimeParaGranularity} + 1) \times \text{GPMC\_FCLK}^{(17)}$

(6) For csn falling edge (CS activated):

- Case GPMCFCLKDIVIDER = 0:
  - $F = 0.5 \times \text{CSEExtraDelay} \times \text{GPMC\_FCLK}^{(17)}$
- Case GPMCFCLKDIVIDER = 1:
  - $F = 0.5 \times \text{CSEExtraDelay} \times \text{GPMC\_FCLK}^{(17)}$  if (ClkActivationTime and CSOnTime are odd) or (ClkActivationTime and CSOnTime are even)
  - $F = (1 + 0.5 \times \text{CSEExtraDelay}) \times \text{GPMC\_FCLK}^{(17)}$  otherwise
- Case GPMCFCLKDIVIDER = 2:
  - $F = 0.5 \times \text{CSEExtraDelay} \times \text{GPMC\_FCLK}^{(17)}$  if ((CSOnTime - ClkActivationTime) is a multiple of 3)
  - $F = (1 + 0.5 \times \text{CSEExtraDelay}) \times \text{GPMC\_FCLK}^{(17)}$  if ((CSOnTime - ClkActivationTime - 1) is a multiple of 3)
  - $F = (2 + 0.5 \times \text{CSEExtraDelay}) \times \text{GPMC\_FCLK}^{(17)}$  if ((CSOnTime - ClkActivationTime - 2) is a multiple of 3)

(7) For ADV falling edge (ADV activated):

- Case GPMCFCLKDIVIDER = 0:
  - $G = 0.5 \times \text{ADVExtraDelay} \times \text{GPMC\_FCLK}^{(17)}$
- Case GPMCFCLKDIVIDER = 1:
  - $G = 0.5 \times \text{ADVExtraDelay} \times \text{GPMC\_FCLK}^{(17)}$  if (ClkActivationTime and ADVOnTime are odd) or (ClkActivationTime and ADVOnTime are even)
  - $G = (1 + 0.5 \times \text{ADVExtraDelay}) \times \text{GPMC\_FCLK}^{(17)}$  otherwise
- Case GPMCFCLKDIVIDER = 2:
  - $G = 0.5 \times \text{ADVExtraDelay} \times \text{GPMC\_FCLK}^{(17)}$  if ((ADVOnTime - ClkActivationTime) is a multiple of 3)
  - $G = (1 + 0.5 \times \text{ADVExtraDelay}) \times \text{GPMC\_FCLK}^{(17)}$  if ((ADVOnTime - ClkActivationTime - 1) is a multiple of 3)
  - $G = (2 + 0.5 \times \text{ADVExtraDelay}) \times \text{GPMC\_FCLK}^{(17)}$  if ((ADVOnTime - ClkActivationTime - 2) is a multiple of 3)

For ADV rising edge (ADV deactivated) in Reading mode:

- Case GPMCFCLKDIVIDER = 0:
  - $G = 0.5 \times \text{ADVExtraDelay} \times \text{GPMC\_FCLK}^{(17)}$
- Case GPMCFCLKDIVIDER = 1:
  - $G = 0.5 \times \text{ADVExtraDelay} \times \text{GPMC\_FCLK}^{(17)}$  if (ClkActivationTime and ADVRdOffTime are odd) or (ClkActivationTime and ADVRdOffTime are even)
  - $G = (1 + 0.5 \times \text{ADVExtraDelay}) \times \text{GPMC\_FCLK}^{(17)}$  otherwise
- Case GPMCFCLKDIVIDER = 2:
  - $G = 0.5 \times \text{ADVExtraDelay} \times \text{GPMC\_FCLK}^{(17)}$  if ((ADVRdOffTime - ClkActivationTime) is a multiple of 3)
  - $G = (1 + 0.5 \times \text{ADVExtraDelay}) \times \text{GPMC\_FCLK}^{(17)}$  if ((ADVRdOffTime - ClkActivationTime - 1) is a multiple of 3)
  - $G = (2 + 0.5 \times \text{ADVExtraDelay}) \times \text{GPMC\_FCLK}^{(17)}$  if ((ADVRdOffTime - ClkActivationTime - 2) is a multiple of 3)

For ADV rising edge (ADV deactivated) in Writing mode:

- Case GPMCFCLKDIVIDER = 0:

- $G = 0.5 \times \text{ADVExtraDelay} \times \text{GPMC\_FCLK}^{(17)}$
  - Case GPMCFCLKDIVIDER = 1:
    - $G = 0.5 \times \text{ADVExtraDelay} \times \text{GPMC\_FCLK}^{(17)}$  if (ClkActivationTime and ADVWrOffTime are odd) or (ClkActivationTime and ADVWrOffTime are even)
    - $G = (1 + 0.5 \times \text{ADVExtraDelay}) \times \text{GPMC\_FCLK}^{(17)}$  otherwise
  - Case GPMCFCLKDIVIDER = 2:
    - $G = 0.5 \times \text{ADVExtraDelay} \times \text{GPMC\_FCLK}^{(17)}$  if ((ADVWrOffTime - ClkActivationTime) is a multiple of 3)
    - $G = (1 + 0.5 \times \text{ADVExtraDelay}) \times \text{GPMC\_FCLK}^{(17)}$  if ((ADVWrOffTime - ClkActivationTime - 1) is a multiple of 3)
    - $G = (2 + 0.5 \times \text{ADVExtraDelay}) \times \text{GPMC\_FCLK}^{(17)}$  if ((ADVWrOffTime - ClkActivationTime - 2) is a multiple of 3)
- (8) For OE falling edge (OE activated) and IO DIR rising edge (Data Bus input direction):
- Case GPMCFCLKDIVIDER = 0:
    - $H = 0.5 \times \text{OEEExtraDelay} \times \text{GPMC\_FCLK}^{(17)}$
  - Case GPMCFCLKDIVIDER = 1:
    - $H = 0.5 \times \text{OEEExtraDelay} \times \text{GPMC\_FCLK}^{(17)}$  if (ClkActivationTime and OEOnTime are odd) or (ClkActivationTime and OEOnTime are even)
    - $H = (1 + 0.5 \times \text{OEEExtraDelay}) \times \text{GPMC\_FCLK}^{(17)}$  otherwise
  - Case GPMCFCLKDIVIDER = 2:
    - $H = 0.5 \times \text{OEEExtraDelay} \times \text{GPMC\_FCLK}^{(17)}$  if ((OEOnTime - ClkActivationTime) is a multiple of 3)
    - $H = (1 + 0.5 \times \text{OEEExtraDelay}) \times \text{GPMC\_FCLK}^{(17)}$  if ((OEOnTime - ClkActivationTime - 1) is a multiple of 3)
    - $H = (2 + 0.5 \times \text{OEEExtraDelay}) \times \text{GPMC\_FCLK}^{(17)}$  if ((OEOnTime - ClkActivationTime - 2) is a multiple of 3)
- For OE rising edge (OE deactivated):
- Case GPMCFCLKDIVIDER = 0:
    - $H = 0.5 \times \text{OEEExtraDelay} \times \text{GPMC\_FCLK}^{(17)}$
  - Case GPMCFCLKDIVIDER = 1:
    - $H = 0.5 \times \text{OEEExtraDelay} \times \text{GPMC\_FCLK}^{(17)}$  if (ClkActivationTime and OEOffTime are odd) or (ClkActivationTime and OEOffTime are even)
    - $H = (1 + 0.5 \times \text{OEEExtraDelay}) \times \text{GPMC\_FCLK}^{(17)}$  otherwise
  - Case GPMCFCLKDIVIDER = 2:
    - $H = 0.5 \times \text{OEEExtraDelay} \times \text{GPMC\_FCLK}^{(17)}$  if ((OEOffTime - ClkActivationTime) is a multiple of 3)
    - $H = (1 + 0.5 \times \text{OEEExtraDelay}) \times \text{GPMC\_FCLK}^{(17)}$  if ((OEOffTime - ClkActivationTime - 1) is a multiple of 3)
    - $H = (2 + 0.5 \times \text{OEEExtraDelay}) \times \text{GPMC\_FCLK}^{(17)}$  if ((OEOffTime - ClkActivationTime - 2) is a multiple of 3)
- (9) For WE falling edge (WE activated):
- Case GPMCFCLKDIVIDER = 0:
    - $I = 0.5 \times \text{WEEExtraDelay} \times \text{GPMC\_FCLK}^{(17)}$
  - Case GPMCFCLKDIVIDER = 1:
    - $I = 0.5 \times \text{WEEExtraDelay} \times \text{GPMC\_FCLK}^{(17)}$  if (ClkActivationTime and WEOnTime are odd) or (ClkActivationTime and WEOnTime are even)
    - $I = (1 + 0.5 \times \text{WEEExtraDelay}) \times \text{GPMC\_FCLK}^{(17)}$  otherwise
  - Case GPMCFCLKDIVIDER = 2:
    - $I = 0.5 \times \text{WEEExtraDelay} \times \text{GPMC\_FCLK}^{(17)}$  if ((WEOnTime - ClkActivationTime) is a multiple of 3)
    - $I = (1 + 0.5 \times \text{WEEExtraDelay}) \times \text{GPMC\_FCLK}^{(17)}$  if ((WEOnTime - ClkActivationTime - 1) is a multiple of 3)
    - $I = (2 + 0.5 \times \text{WEEExtraDelay}) \times \text{GPMC\_FCLK}^{(17)}$  if ((WEOnTime - ClkActivationTime - 2) is a multiple of 3)
- For WE rising edge (WE deactivated):
- Case GPMCFCLKDIVIDER = 0:
    - $I = 0.5 \times \text{WEEExtraDelay} \times \text{GPMC\_FCLK}^{(17)}$
  - Case GPMCFCLKDIVIDER = 1:
    - $I = 0.5 \times \text{WEEExtraDelay} \times \text{GPMC\_FCLK}^{(17)}$  if (ClkActivationTime and WEOffTime are odd) or (ClkActivationTime and WEOffTime are even)
    - $I = (1 + 0.5 \times \text{WEEExtraDelay}) \times \text{GPMC\_FCLK}^{(17)}$  otherwise
  - Case GPMCFCLKDIVIDER = 2:
    - $I = 0.5 \times \text{WEEExtraDelay} \times \text{GPMC\_FCLK}^{(17)}$  if ((WEOffTime - ClkActivationTime) is a multiple of 3)
    - $I = (1 + 0.5 \times \text{WEEExtraDelay}) \times \text{GPMC\_FCLK}^{(17)}$  if ((WEOffTime - ClkActivationTime - 1) is a multiple of 3)

- $I = (2 + 0.5 \times \text{WEEExtraDelay}) \times \text{GPMC\_FCLK}^{(17)}$  if  $((\text{WEOffTime} - \text{ClkActivationTime} - 2)$  is a multiple of 3)
- (10)  $J = \text{GPMC\_FCLK}^{(17)}$
- (11) First transfer only for CLK DIV 1 mode.
- (12) Half cycle; for all data after initial transfer for CLK DIV 1 mode.
- (13) Half cycle of GPMC\_CLKOUT; for all data for modes other than CLK DIV 1 mode. GPMC\_CLKOUT divide down from GPMC\_FCLK.
- (14) In GPMC\_CS*n*[*i*], *i* is equal to 0, 1, 2, or 3. In GPMC\_WAIT*j*[], *j* is equal to 0, 1, 2, or 3.
- (15)  $P = \text{GPMC\_CLK}$  period in ns
- (16) For read:  $K = (\text{ADVrOffTime} - \text{ADVOnTime}) \times (\text{TimeParaGranularity} + 1) \times \text{GPMC\_FCLK}^{(17)}$   
For write:  $K = (\text{ADVrOffTime} - \text{ADVOnTime}) \times (\text{TimeParaGranularity} + 1) \times \text{GPMC\_FCLK}^{(17)}$
- (17) GPMC\_FCLK is general-purpose memory controller internal functional clock period in ns.
- (18) Related to the GPMC\_CLK output clock maximum and minimum frequencies programmable in the GPMC module by setting the GPMC\_CONFIG1\_*i* configuration register bit field GPMCFCLKDIVIDER.
- (19) For div\_by\_1\_mode:
  - GPMC\_CONFIG1\_*i* register: GPMCFCLKDIVIDER = 0h:
    - GPMC\_CLK frequency = GPMC\_FCLK frequency
  - CTRLMMR\_GPMC\_CLKSEL[1-0] CLK\_SEL = 01 = PER1\_PLL\_CLKOUT / 3 = 300 / 3 = 100 MHz
  - GPMC\_CONFIG1\_*i* Register: TIMEPARAGRANULARITY = 0h = x1 latencies (affecting RD/WRCYCLETIME, RD/WRACCESSTIME, PAGEBURSTACCESSTIME, CSONTIME, CSRD/WROFFTIME, ADVONTIME, ADVRD/WROFFTIME, OEONTIME, OEOFFTIME, WEONTIME, WEOFFTIME, CYCLE2CYCLEDELAY, BUSTURNAROUND, TIMEOUTSTARTVALUE, WRDATAONADMUXBUS)
- For no extra\_delay:
  - GPMC\_CONFIG2\_*i* Register: CSEXTRADELAY = 0h = CS*n* Timing control signal is not delayed
  - GPMC\_CONFIG4\_*i* Register: WEEXTRADELAY = 0h = nWE timing control signal is not delayed
  - GPMC\_CONFIG4\_*i* Register: OEEXTRADELAY = 0h = nOE timing control signal is not delayed
  - GPMC\_CONFIG3\_*i* Register: ADVEXTRADELAY = 0h = nADV timing control signal is not delayed
- (20) For 100 MHz:
  - CTRLMMR\_GPMC\_CLKSEL[1-0] CLK\_SEL = 01 = MAIN\_PLL2\_HSDIV1\_CLKOUT / 3
- For 133 MHz:
  - CTRLMMR\_GPMC\_CLKSEL[1-0] CLK\_SEL = 00 = MAIN\_PLL0\_HSDIV3\_CLKOUT

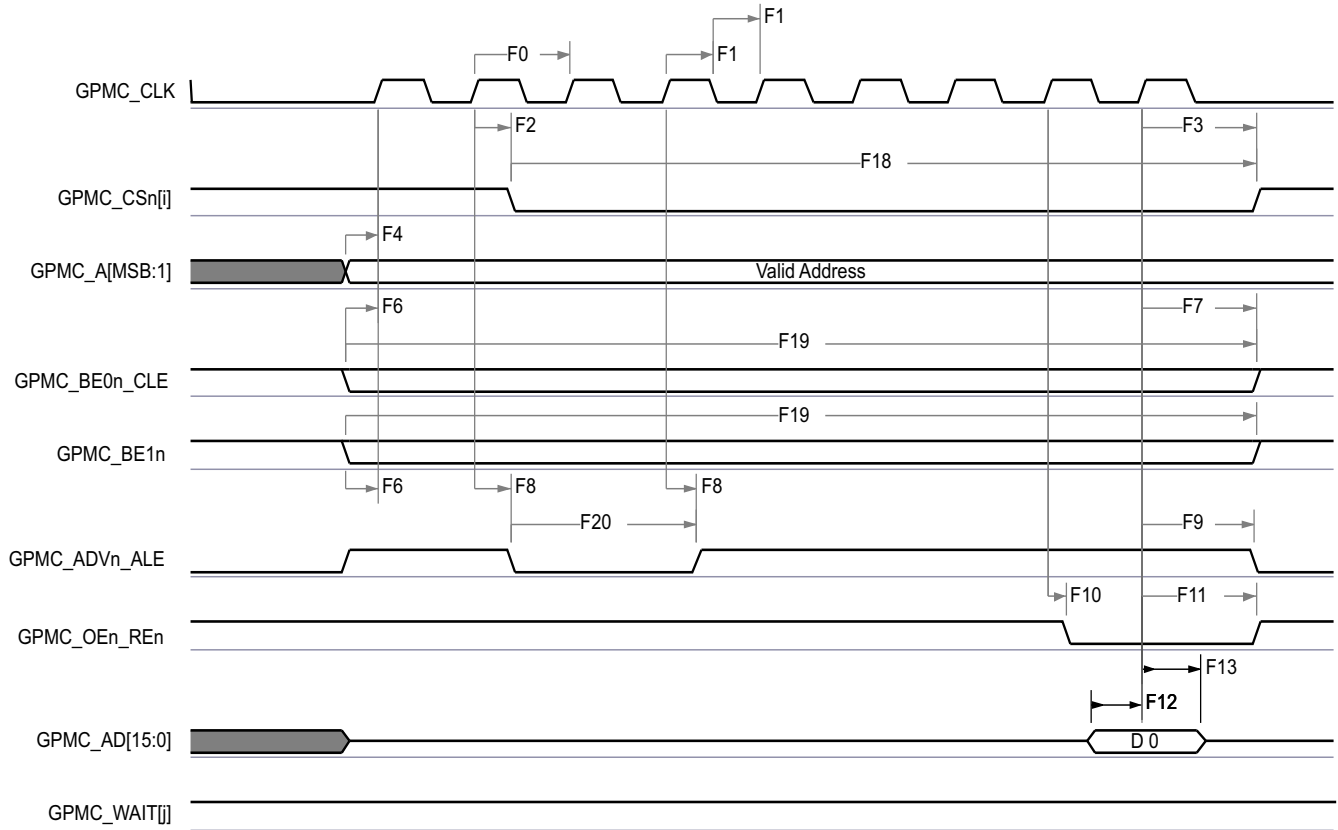

GPMC\_01

- A. In GPMC\_CSn[i], i is equal to 0, 1, 2 or 3.
- B. In GPMC\_WAIT[j], j is equal to 0, 1, 2, or 3.

**7-51. GPMC and NOR Flash — Synchronous Single Read (GPMCFCLKDIVIDER = 0)**



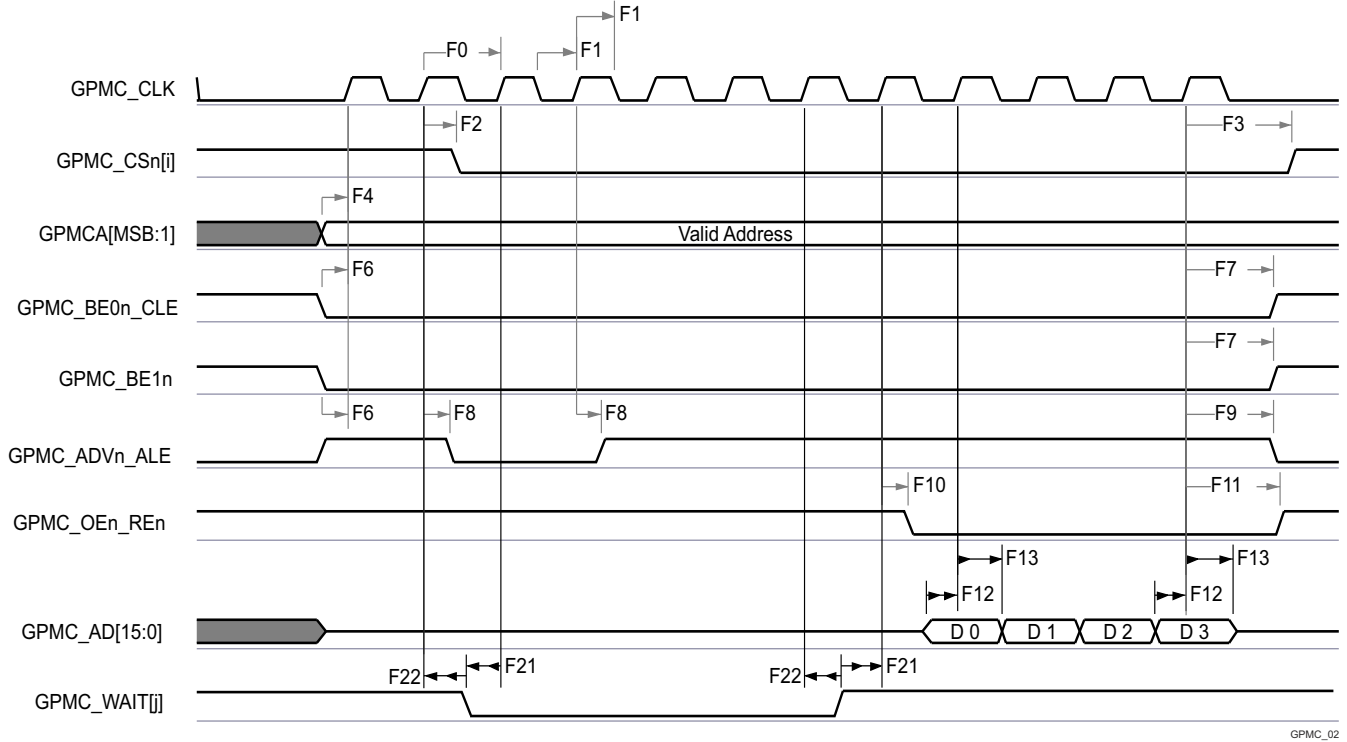

GPMC\_02

- A. In GPMC\_CS[n], i is equal to 0, 1, 2 or 3.
- B. In GPMC\_WAIT[j], j is equal to 0, 1, 2, or 3.

**FIG 7-52. GPMC and NOR Flash — Synchronous Burst Read — 4x16-bit (GPMCCLKDIVIDER = 0)**

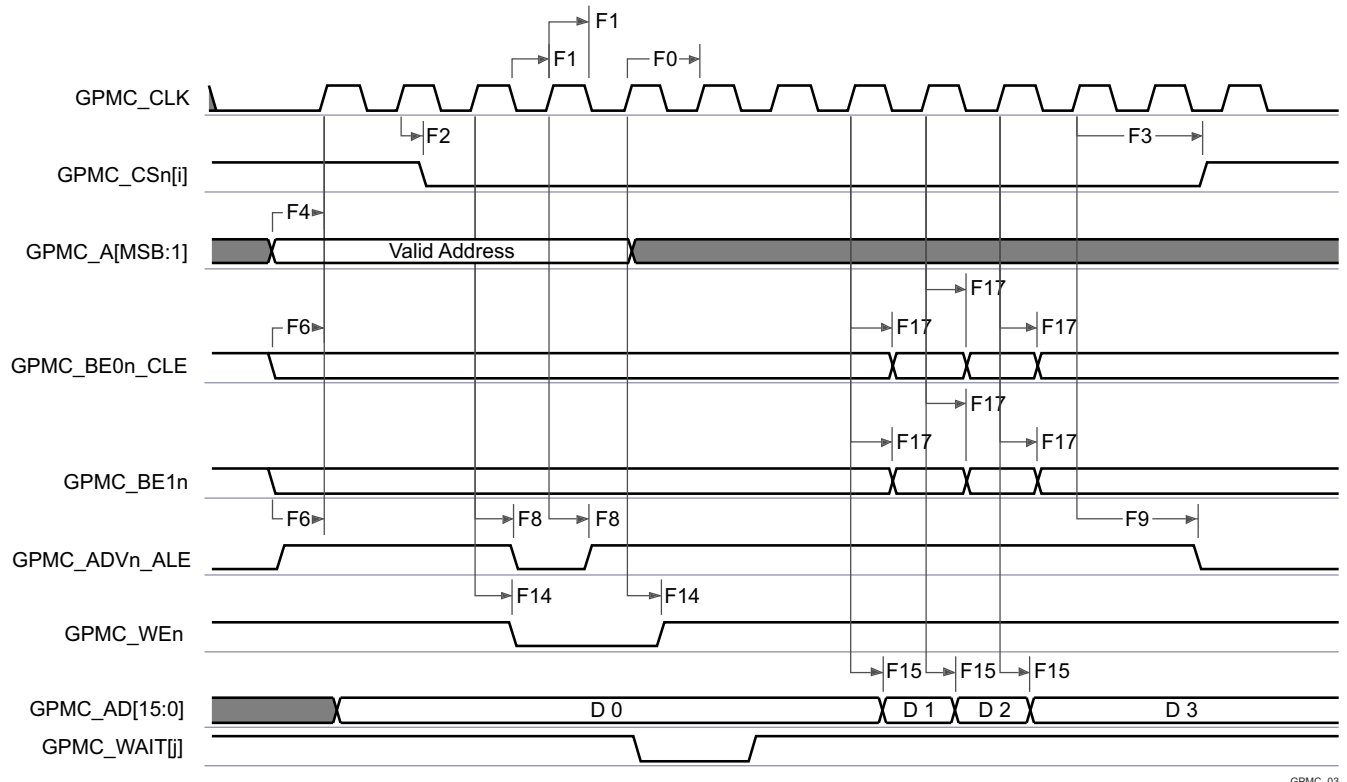

GPMC\_03

- A. In GPMC\_CS[n], i is equal to 0, 1, 2 or 3.

ADVANCE INFORMATION

B. In GPMC\_WAIT[j], j is equal to 0, 1, 2, or 3.

**7-53. GPMC and NOR Flash—Synchronous Burst Write (GPMCFCLKDIVIDER = 0)**

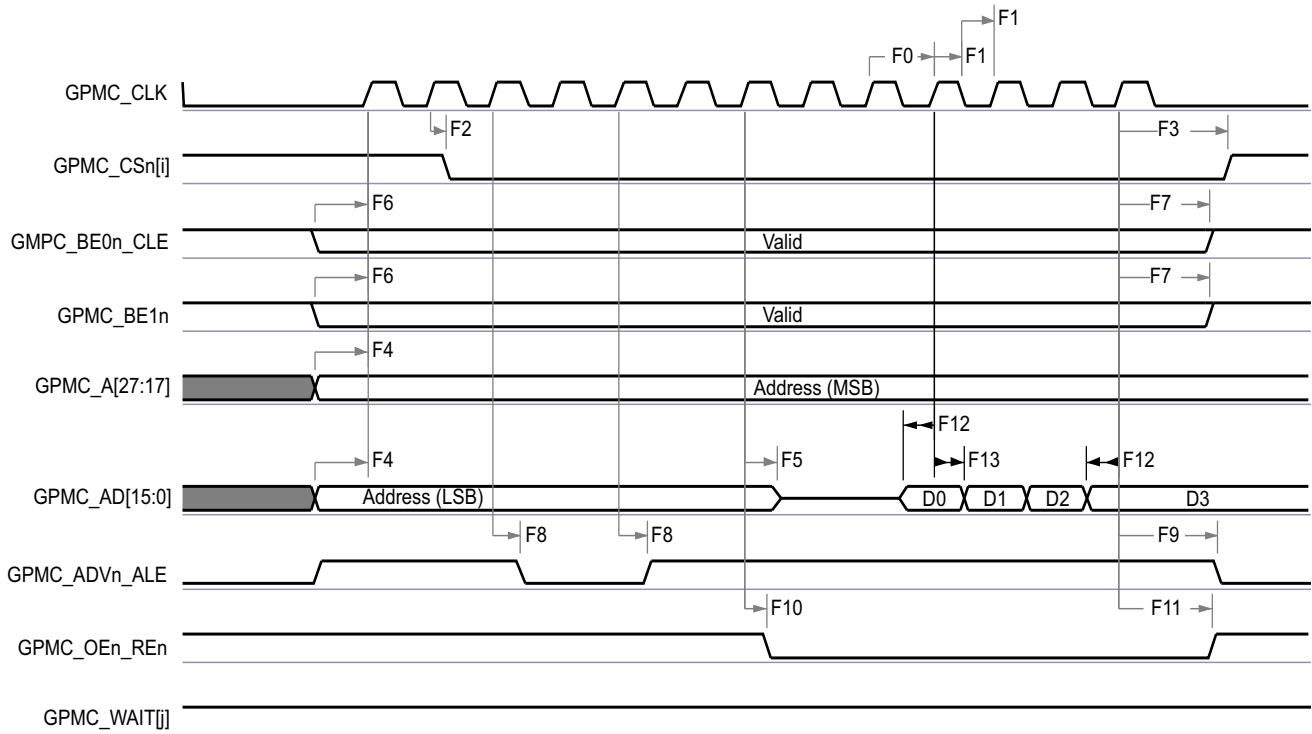

GPMC\_04

A. In GPMC\_CSn[i], i is equal to 0, 1, 2 or 3.

B. In GPMC\_WAIT[j], j is equal to 0, 1, 2, or 3.

**7-54. GPMC and Multiplexed NOR Flash — Synchronous Burst Read**

ADVANCE INFORMATION

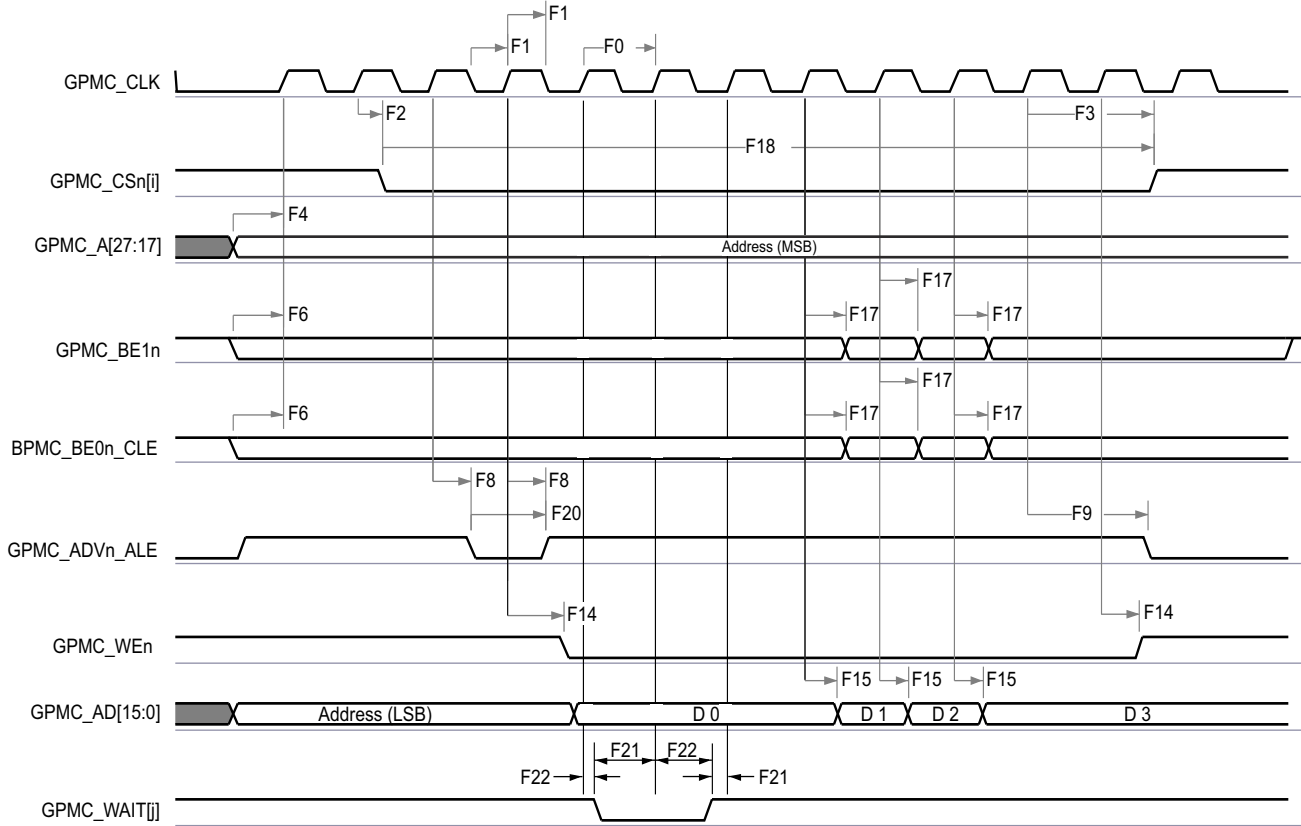

GPMC\_05

- A. In GPMC\_CS[n], i is equal to 0, 1, 2 or 3.
- B. In GPMC\_WAIT[j], j is equal to 0, 1, 2, or 3.

**7-55. GPMC and Multiplexed NOR Flash — Synchronous Burst Write**

**7.10.5.10.2 GPMC and NOR Flash — Asynchronous Mode**

セクション 7.10.5.10.2.1 and セクション 7.10.5.10.2.2 assume testing over the recommended operating conditions and electrical characteristic conditions below (see 7-56 through 7-61).

**7.10.5.10.2.1 GPMC and NOR Flash Timing Requirements – Asynchronous Mode**

NO.			MODE <sup>(7)</sup>	MIN	MAX	UNIT
FA5 <sup>(1)</sup>	t <sub>acc(d)</sub>	Data access time	div_by_1_mode ; GPMC_FCLK_MUX; TIMEPARAGRANULARITY_X 1		H <sup>(5)</sup>	ns
FA20 <sup>(2)</sup>	t <sub>acc1-pgmode(d)</sub>	Page mode successive data access time	div_by_1_mode ; GPMC_FCLK_MUX; TIMEPARAGRANULARITY_X 1		P <sup>(4)</sup>	ns
FA21 <sup>(3)</sup>	t <sub>acc2-pgmode(d)</sub>	Page mode first data access time	div_by_1_mode ; GPMC_FCLK_MUX; TIMEPARAGRANULARITY_X 1		H <sup>(5)</sup>	ns

- (1) The FA5 parameter illustrates the amount of time required to internally sample input data. It is expressed in number of GPMC functional clock cycles. From start of read cycle and after FA5 functional clock cycles, input data is internally sampled by active functional clock edge. FA5 value must be stored inside the AccessTime register bit field.
- (2) The FA20 parameter illustrates amount of time required to internally sample successive input page data. It is expressed in number of GPMC functional clock cycles. After each access to input page data, next input page data is internally sampled by active functional clock edge after FA20 functional clock cycles. The FA20 value must be stored in the PageBurstAccessTime register bit field.

- (3) The FA21 parameter illustrates amount of time required to internally sample first input page data. It is expressed in number of GPMC functional clock cycles. From start of read cycle and after FA21 functional clock cycles, first input page data is internally sampled by active functional clock edge. FA21 value must be stored inside the AccessTime register bit field.
- (4)  $P = \text{PageBurstAccessTime} \times (\text{TimeParaGranularity} + 1) \times \text{GPMC\_FCLK}^{(6)}$
- (5)  $H = \text{AccessTime} \times (\text{TimeParaGranularity} + 1) \times \text{GPMC\_FCLK}^{(6)}$
- (6) GPMC\_FCLK is general-purpose memory controller internal functional clock period in ns.
- (7) For div\_by\_1\_mode:
- GPMC\_CONFIG1\_i Register: GPMCFCLKDIVIDER = 0h:
    - GPMC\_CLK frequency = GPMC\_FCLK frequency
  - CTRLMMR\_GPMC\_CLKSEL[1-0] CLK\_SEL = 00 = CPSWHS DIV\_CLKOUT3 = 2000/15 = 133.33 MHz
  - GPMC\_CONFIG1\_i Register: TIMEPARAGRANULARITY = 0h = x1 latencies (affecting RD/WRCYCLETIME, RD/WRACCESSTIME, PAGEBURSTACCESSTIME, CSONTIME, CSRD/WROFFTIME, ADVONTIME, ADVRD/WROFFTIME, OEONTIME, OEOFFTIME, WEONTIME, WEOFFTIME, CYCLE2CYCLEDELAY, BUSTURNAROUND, TIMEOUTSTARTVALUE, WRDATAONADMUXBUS)

### 7.10.5.10.2.2 GPMC and NOR Flash Switching Characteristics – Asynchronous Mode

NO.	PARAMETER	DESCRIPTION	MODE <sup>(15)</sup>	MIN	MAX	UNIT
				133 MHz <sup>(16)</sup>		
FA0	$t_{w(\text{be x nV})}$	Pulse duration, output lower-byte enable and command latch enable GPMC_BE0n_CLE, output upper-byte enable GPMC_BE1n valid time	Read		N <sup>(12)</sup>	ns
			Write		N <sup>(12)</sup>	
FA1	$t_{w(\text{csnV})}$	Pulse duration, output chip select GPMC_CS <i>n</i> [ <i>j</i> ] <sup>(13)</sup> low	Read		A <sup>(1)</sup>	ns
			Write		A <sup>(1)</sup>	
FA3	$t_{d(\text{csnV-advnIV})}$	Delay time, output chip select GPMC_CS <i>n</i> [ <i>j</i> ] <sup>(13)</sup> valid to output address valid and address latch enable GPMC_ADV <i>n</i> _ALE invalid	Read	B <sup>(2)</sup> - 2.55	B <sup>(2)</sup> + 2.65	ns
			Write	B <sup>(2)</sup> - 2.55	B <sup>(2)</sup> + 2.65	
FA4	$t_{d(\text{csnV-oenIV})}$	Delay time, output chip select GPMC_CS <i>n</i> [ <i>j</i> ] <sup>(13)</sup> valid to output enable GPMC_OEn_RE <i>n</i> invalid (Single read)	div_by_1_mode; GPMC_FCLK_MUX; TIMEPARAGRANULARITY_X1	C <sup>(3)</sup> - 2.55	C <sup>(3)</sup> + 2.65	ns
FA9	$t_{d(\text{aV-csnV})}$	Delay time, output address GPMC_A[27:1] valid to output chip select GPMC_CS <i>n</i> [ <i>j</i> ] <sup>(13)</sup> valid	div_by_1_mode; GPMC_FCLK_MUX; TIMEPARAGRANULARITY_X1	J <sup>(9)</sup> - 2.55	J <sup>(9)</sup> + 2.65	ns
FA10	$t_{d(\text{be x nV-csnV})}$	Delay time, output lower-byte enable and command latch enable GPMC_BE0n_CLE, output upper-byte enable GPMC_BE1n valid to output chip select GPMC_CS <i>n</i> [ <i>j</i> ] <sup>(13)</sup> valid	div_by_1_mode; GPMC_FCLK_MUX; TIMEPARAGRANULARITY_X1	J <sup>(9)</sup> - 2.55	J <sup>(9)</sup> + 2.65	ns
FA12	$t_{d(\text{csnV-advnV})}$	Delay time, output chip select GPMC_CS <i>n</i> [ <i>j</i> ] <sup>(13)</sup> valid to output address valid and address latch enable GPMC_ADV <i>n</i> _ALE valid	div_by_1_mode; GPMC_FCLK_MUX; TIMEPARAGRANULARITY_X1	K <sup>(10)</sup> - 2.55	K <sup>(10)</sup> + 2.65	ns
FA13	$t_{d(\text{csnV-oenV})}$	Delay time, output chip select GPMC_CS <i>n</i> [ <i>j</i> ] <sup>(13)</sup> valid to output enable GPMC_OEn_RE <i>n</i> valid	div_by_1_mode; GPMC_FCLK_MUX; TIMEPARAGRANULARITY_X1	L <sup>(11)</sup> - 2.55	L <sup>(11)</sup> + 2.65	ns
FA16	$t_{w(\text{aIV})}$	Pulse duration output address GPMC_A[26:1] invalid between 2 successive read and write accesses	div_by_1_mode; GPMC_FCLK_MUX; TIMEPARAGRANULARITY_X1	G <sup>(7)</sup>		ns
FA18	$t_{d(\text{csnV-oenIV})}$	Delay time, output chip select GPMC_CS <i>n</i> [ <i>j</i> ] <sup>(13)</sup> valid to output enable GPMC_OEn_RE <i>n</i> invalid (Burst read)	div_by_1_mode; GPMC_FCLK_MUX; TIMEPARAGRANULARITY_X1	I <sup>(8)</sup> - 2.55	I <sup>(8)</sup> + 2.65	ns
FA20	$t_{w(\text{aV})}$	Pulse duration, output address GPMC_A[27:1] valid - 2nd, 3rd, and 4th accesses	div_by_1_mode; GPMC_FCLK_MUX; TIMEPARAGRANULARITY_X1	D <sup>(4)</sup>		ns

NO.	PARAMETER	DESCRIPTION	MODE <sup>(15)</sup>	MIN	MAX	UNIT
				133 MHz <sup>(16)</sup>		
FA25	$t_{d(csnV-wenV)}$	Delay time, output chip select GPMC_CS <i>n</i> [ <i>j</i> ] <sup>(13)</sup> valid to output write enable GPMC_WEn valid	div_by_1_mode; GPMC_FCLK_MUX; TIMEPARAGRANULARITY_X1	E <sup>(5)</sup> - 2.55	E <sup>(5)</sup> + 2.65	ns
FA27	$t_{d(csnV-wenIV)}$	Delay time, output chip select GPMC_CS <i>n</i> [ <i>j</i> ] <sup>(13)</sup> valid to output write enable GPMC_WEn invalid	div_by_1_mode; GPMC_FCLK_MUX; TIMEPARAGRANULARITY_X1	F <sup>(6)</sup> - 2.55	F <sup>(6)</sup> + 2.65	ns
FA28	$t_{d(wenV-dV)}$	Delay time, output write enable GPMC_WEn valid to output data GPMC_AD[15:0] valid	div_by_1_mode; GPMC_FCLK_MUX; TIMEPARAGRANULARITY_X1		2.65	ns
FA29	$t_{d(dV-csnV)}$	Delay time, output data GPMC_AD[15:0] valid to output chip select GPMC_CS <i>n</i> [ <i>j</i> ] <sup>(13)</sup> valid	div_by_1_mode; GPMC_FCLK_MUX; TIMEPARAGRANULARITY_X1	J <sup>(9)</sup> - 2.55	J <sup>(9)</sup> + 2.65	ns
FA37	$t_{d(oenV-alV)}$	Delay time, output enable GPMC_OEn_REn valid to output address GPMC_AD[15:0] phase end	div_by_1_mode; GPMC_FCLK_MUX; TIMEPARAGRANULARITY_X1		2.65	ns

- (1) For single read:  $A = (CSRdOffTime - CSOnTime) \times (TimeParaGranularity + 1) \times GPMC\_FCLK^{(14)}$   
 For single write:  $A = (CSWrOffTime - CSOnTime) \times (TimeParaGranularity + 1) \times GPMC\_FCLK^{(14)}$   
 For burst read:  $A = (CSRdOffTime - CSOnTime + (n - 1) \times PageBurstAccessTime) \times (TimeParaGranularity + 1) \times GPMC\_FCLK^{(14)}$   
 For burst write:  $A = (CSWrOffTime - CSOnTime + (n - 1) \times PageBurstAccessTime) \times (TimeParaGranularity + 1) \times GPMC\_FCLK^{(14)}$   
 with n being the page burst access number
- (2) For reading:  $B = ((ADVrOffTime - CSOnTime) \times (TimeParaGranularity + 1) + 0.5 \times (ADVExtraDelay - CSEExtraDelay)) \times GPMC\_FCLK^{(14)}$   
 For writing:  $B = ((ADVwOffTime - CSOnTime) \times (TimeParaGranularity + 1) + 0.5 \times (ADVExtraDelay - CSEExtraDelay)) \times GPMC\_FCLK^{(14)}$
- (3)  $C = ((OEOffTime - CSOnTime) \times (TimeParaGranularity + 1) + 0.5 \times (OEEExtraDelay - CSEExtraDelay)) \times GPMC\_FCLK^{(14)}$
- (4)  $D = PageBurstAccessTime \times (TimeParaGranularity + 1) \times GPMC\_FCLK^{(14)}$
- (5)  $E = ((WEOnTime - CSOnTime) \times (TimeParaGranularity + 1) + 0.5 \times (WEEExtraDelay - CSEExtraDelay)) \times GPMC\_FCLK^{(14)}$
- (6)  $F = ((WEOffTime - CSOnTime) \times (TimeParaGranularity + 1) + 0.5 \times (WEEExtraDelay - CSEExtraDelay)) \times GPMC\_FCLK^{(14)}$
- (7)  $G = Cycle2CycleDelay \times GPMC\_FCLK^{(14)}$
- (8)  $I = ((OEOffTime + (n - 1) \times PageBurstAccessTime - CSOnTime) \times (TimeParaGranularity + 1) + 0.5 \times (OEEExtraDelay - CSEExtraDelay)) \times GPMC\_FCLK^{(14)}$
- (9)  $J = (CSOnTime \times (TimeParaGranularity + 1) + 0.5 \times CSEExtraDelay) \times GPMC\_FCLK^{(14)}$
- (10)  $K = ((ADVOnTime - CSOnTime) \times (TimeParaGranularity + 1) + 0.5 \times (ADVExtraDelay - CSEExtraDelay)) \times GPMC\_FCLK^{(14)}$
- (11)  $L = ((OEOnTime - CSOnTime) \times (TimeParaGranularity + 1) + 0.5 \times (OEEExtraDelay - CSEExtraDelay)) \times GPMC\_FCLK^{(14)}$
- (12) For single read:  $N = RdCycleTime \times (TimeParaGranularity + 1) \times GPMC\_FCLK^{(14)}$   
 For single write:  $N = WrCycleTime \times (TimeParaGranularity + 1) \times GPMC\_FCLK^{(14)}$   
 For burst read:  $N = (RdCycleTime + (n - 1) \times PageBurstAccessTime) \times (TimeParaGranularity + 1) \times GPMC\_FCLK^{(14)}$   
 For burst write:  $N = (WrCycleTime + (n - 1) \times PageBurstAccessTime) \times (TimeParaGranularity + 1) \times GPMC\_FCLK^{(14)}$
- (13) In GPMC\_CS*n*[*i*], i is equal to 0, 1, 2 or 3.
- (14) GPMC\_FCLK is general-purpose memory controller internal functional clock period in ns.
- (15) For div\_by\_1\_mode:
  - GPMC\_CONFIG1\_i Register: GPMCFCLKDIVIDER = 0h:
    - GPMC\_CLK frequency = GPMC\_FCLK frequency
  - CTRLMMR\_GPMC\_CLKSEL[1-0] CLK\_SEL = 00 = CPSWHS DIV\_CLKOUT3 = 2000/15 = 133.33 MHz
  - GPMC\_CONFIG1\_i Register: TIMEPARAGRANULARITY = 0h = x1 latencies (affecting RD/WRCYCLETIME, RD/WRACCESSTIME, PAGEBURSTACCESSTIME, CSONTIME, CSRd/WROFFTIME, ADVONTIME, ADVRD/WROFFTIME, OEONTIME, OEOFFTIME, WEONTIME, WEOFFTIME, CYCLE2CYCLEDELAY, BUSTURNAROUND, TIMEOUTSTARTVALUE, WRDATAONADMUXBUS)
- (16) For 133 MHz:
  - CTRLMMR\_GPMC\_CLKSEL[1-0] CLK\_SEL = 00 = MAIN\_PLL0\_HSDIV3\_CLKOUT

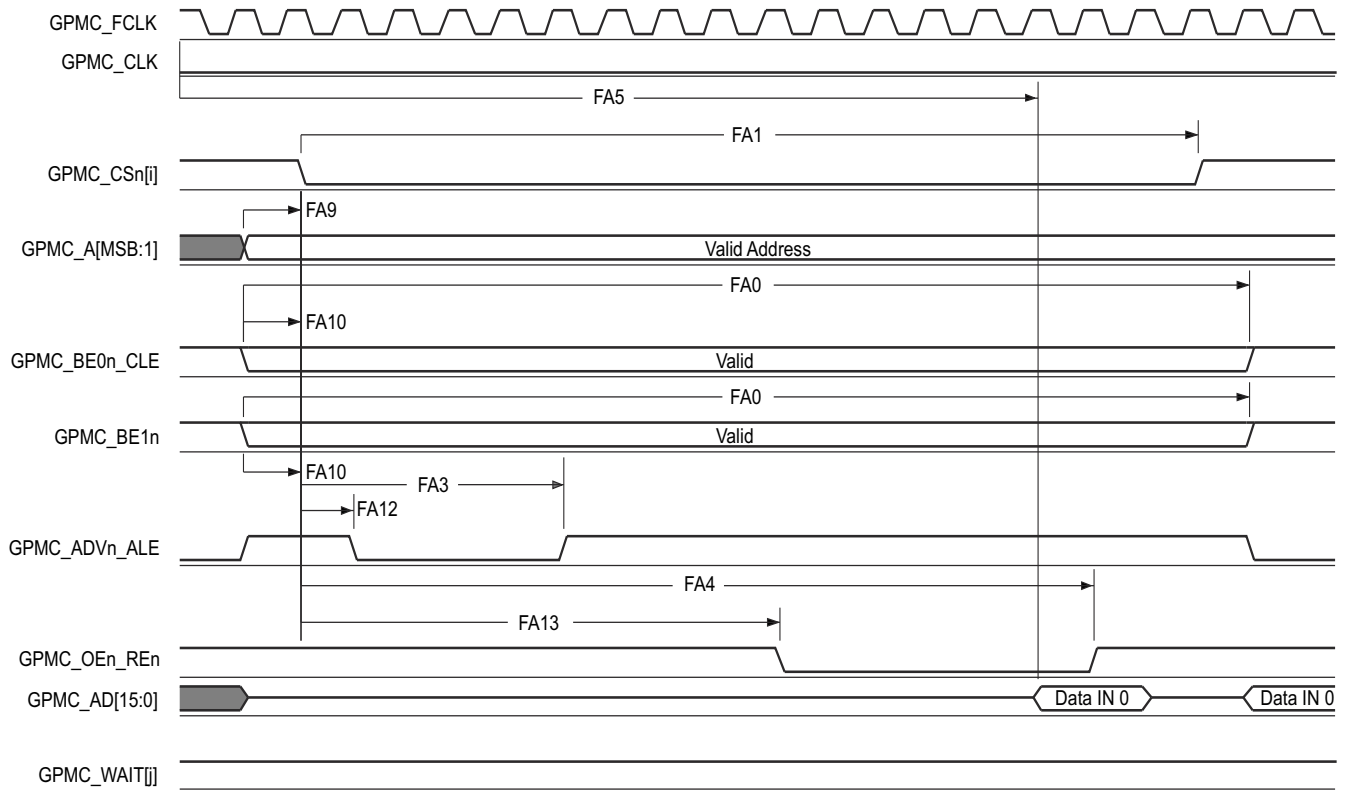

GPMC\_06

- A. In GPMC\_CS*n*[*i*], *i* is equal to 0, 1, 2 or 3. In GPMC\_WAIT[j], *j* is equal to 0, 1, 2, or 3.
- B. FA5 parameter illustrates amount of time required to internally sample input data. It is expressed in number of GPMC functional clock cycles. From start of read cycle and after FA5 functional clock cycles, input data will be internally sampled by active functional clock edge. FA5 value must be stored inside AccessTime register bits field.
- C. GPMC\_FCLK is an internal clock (GPMC functional clock) not provided externally.

**7-56. GPMC and NOR Flash — Asynchronous Read — Single Word**

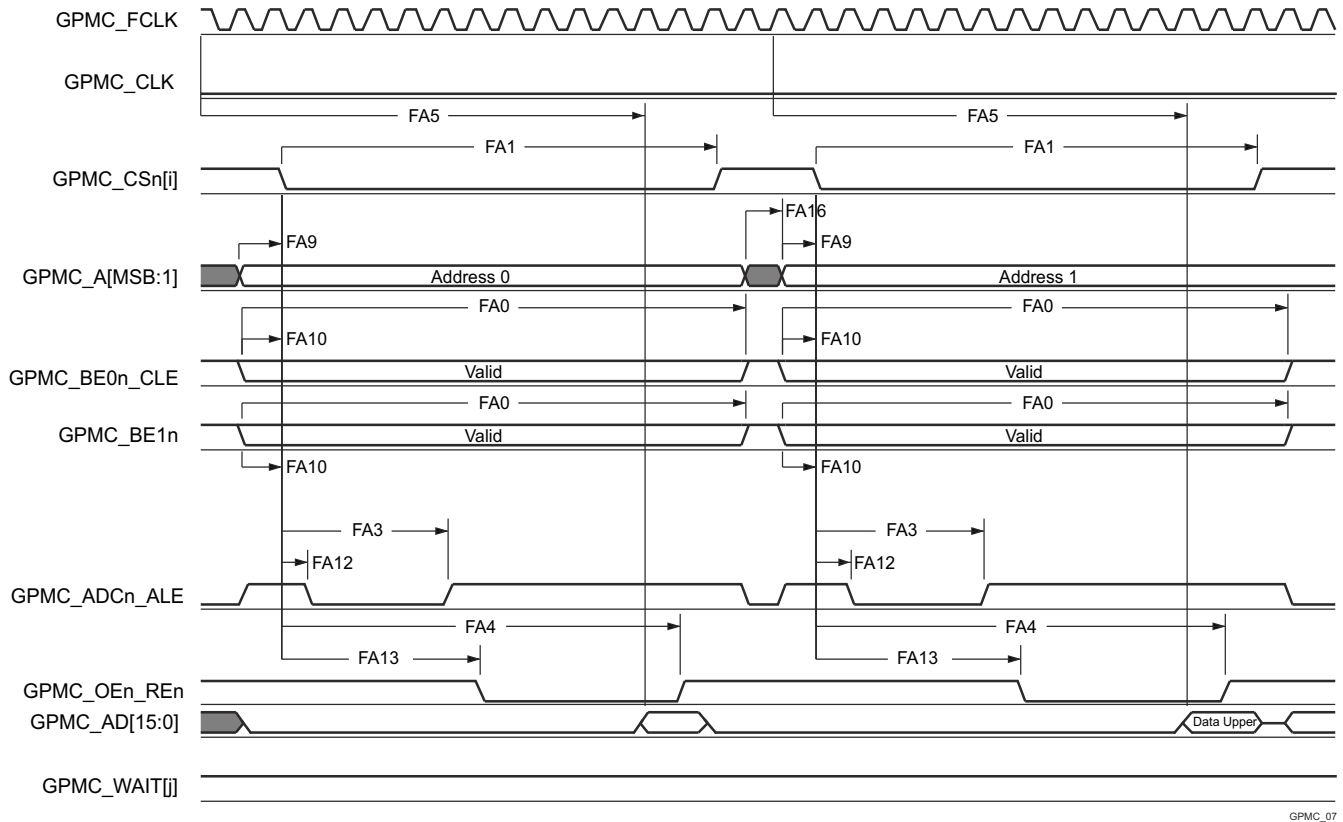

GPMC\_07

- A. In GPMC\_CS*n*[*i*], *i* is equal to 0, 1, 2 or 3. In GPMC\_WAIT[j], *j* is equal to 0, 1, 2, or 3.
- B. FA5 parameter illustrates amount of time required to internally sample input data. It is expressed in number of GPMC functional clock cycles. From start of read cycle and after FA5 functional clock cycles, input data will be internally sampled by active functional clock edge. FA5 value must be stored inside AccessTime register bits field.
- C. GPMC\_FCLK is an internal clock (GPMC functional clock) not provided externally.

**7-57. GPMC and NOR Flash — Asynchronous Read — 32-Bit**

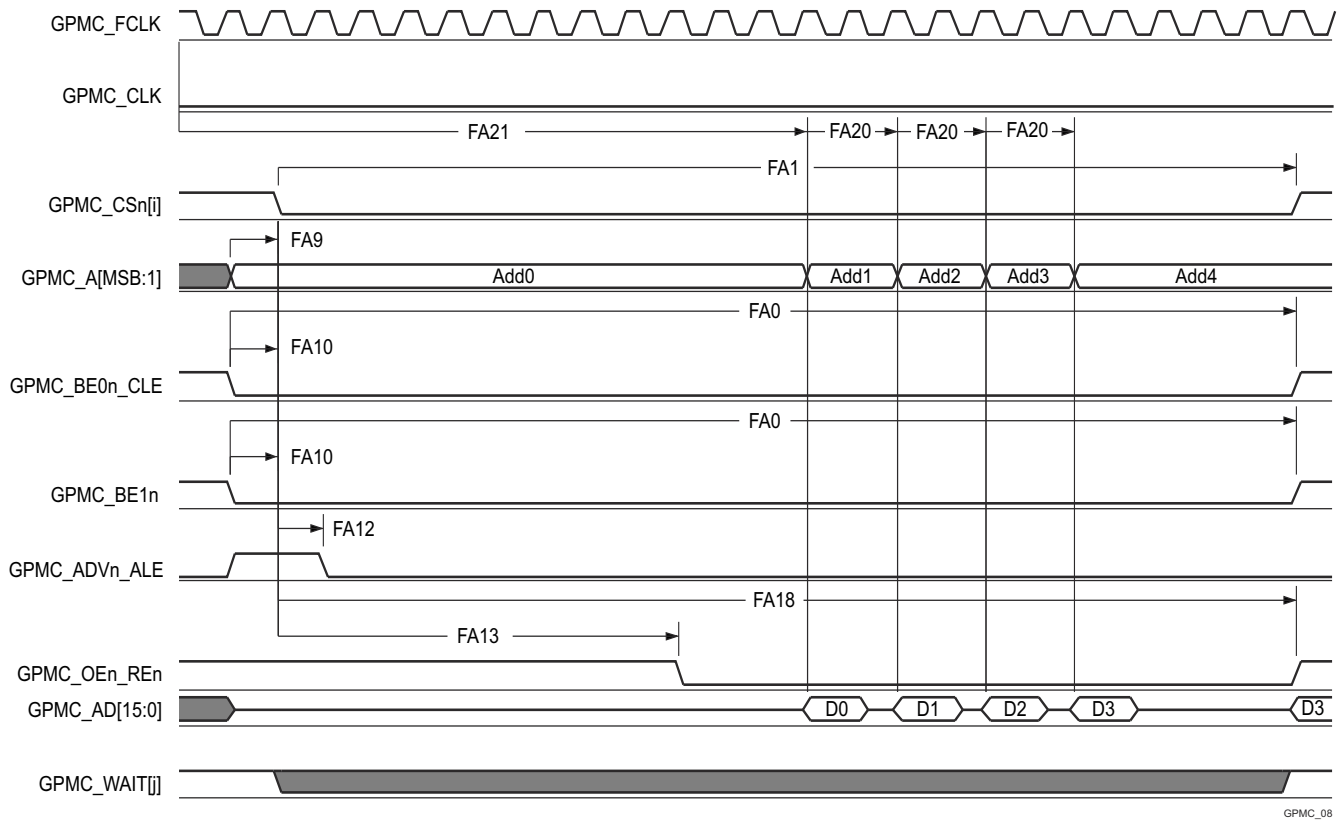

GPMC\_08

- A. In GPMC\_CS*n*[*i*], *i* is equal to 0, 1, 2 or 3. In GPMC\_WAIT[j], *j* is equal to 0, 1, 2, or 3.
- B. FA21 parameter illustrates amount of time required to internally sample first input page data. It is expressed in number of GPMC functional clock cycles. From start of read cycle and after FA21 functional clock cycles, first input page data will be internally sampled by active functional clock edge. FA21 calculation must be stored inside AccessTime register bits field.
- C. FA20 parameter illustrates amount of time required to internally sample successive input page data. It is expressed in number of GPMC functional clock cycles. After each access to input page data, next input page data will be internally sampled by active functional clock edge after FA20 functional clock cycles. FA20 is also the duration of address phases for successive input page data (excluding first input page data). FA20 value must be stored in PageBurstAccessTime register bits field.
- D. GPMC\_FCLK is an internal clock (GPMC functional clock) not provided externally.

**7-58. GPMC and NOR Flash — Asynchronous Read — Page Mode 4x16-Bit**



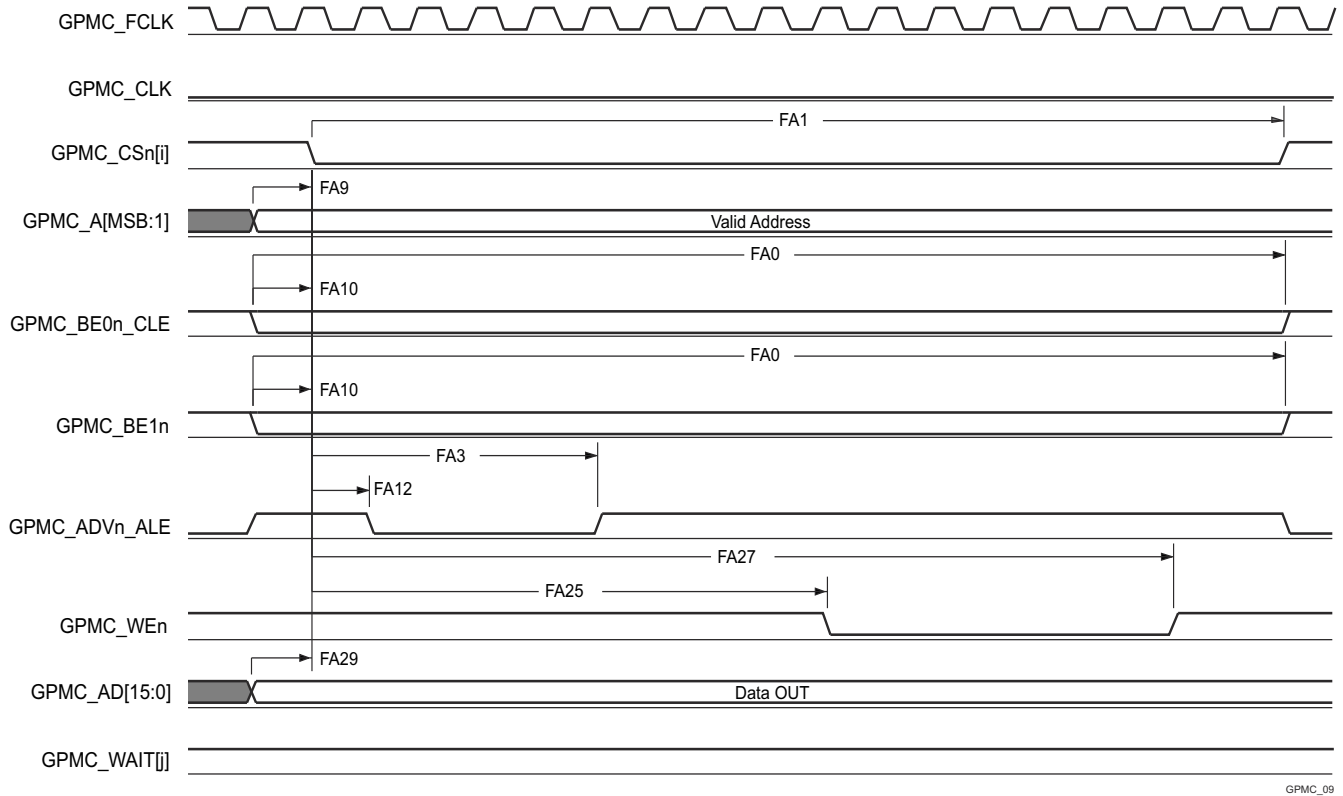

GPMC\_09

A. In GPMC\_CS*n*[*i*], *i* is equal to 0, 1, 2 or 3. In GPMC\_WAIT[j], *j* is equal to 0, 1, 2, or 3.

**7-59. GPMC and NOR Flash — Asynchronous Write — Single Word**

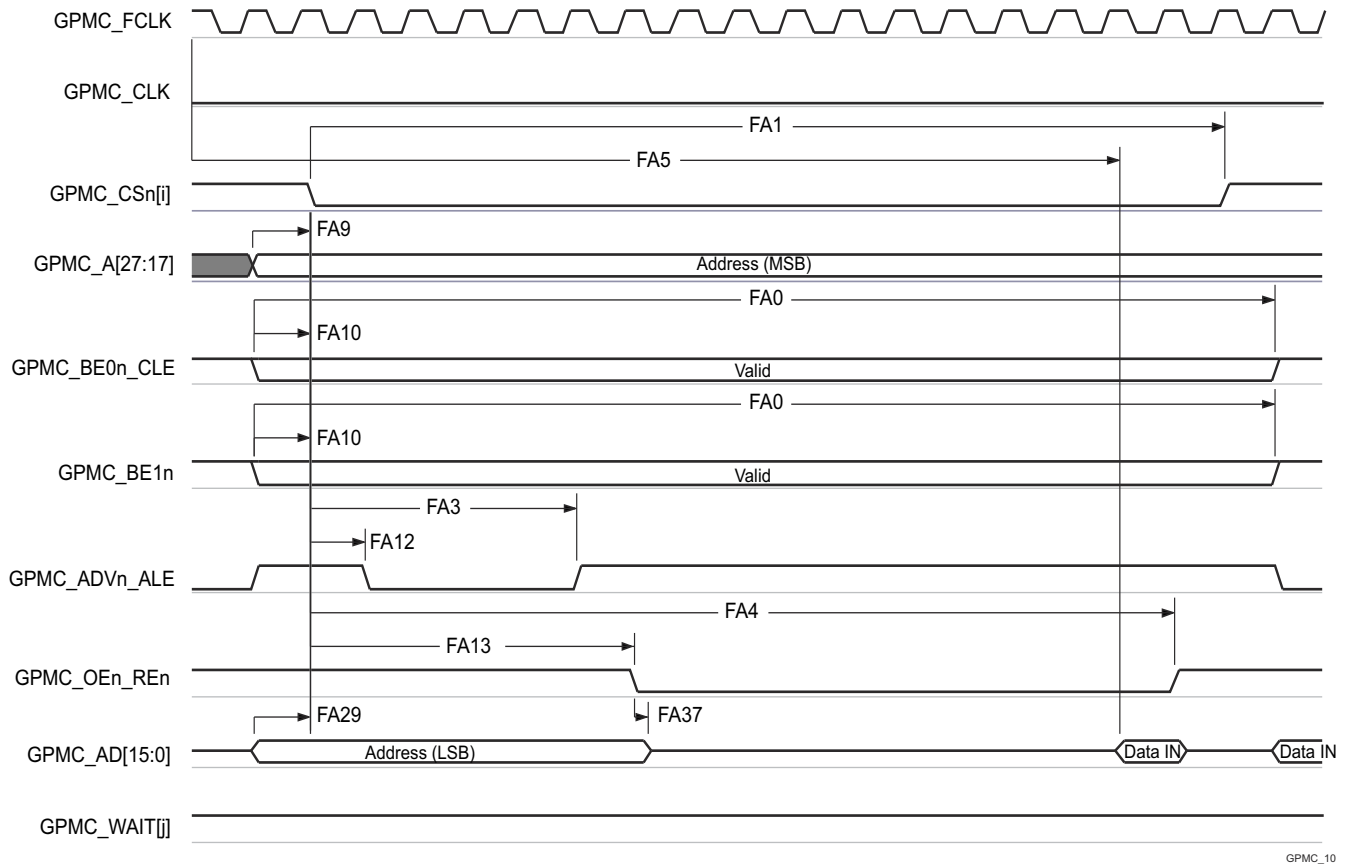

GPMC\_10

- A. In GPMC\_CSn[i], i is equal to 0, 1, 2 or 3. In GPMC\_WAIT[j], j is equal to 0, 1, 2, or 3.
- B. FA5 parameter illustrates amount of time required to internally sample input data. It is expressed in number of GPMC functional clock cycles. From start of read cycle and after FA5 functional clock cycles, input data will be internally sampled by active functional clock edge. FA5 value must be stored inside AccessTime register bits field.
- C. GPMC\_FCLK is an internal clock (GPMC functional clock) not provided externally.

**7-60. GPMC and Multiplexed NOR Flash — Asynchronous Read — Single Word**

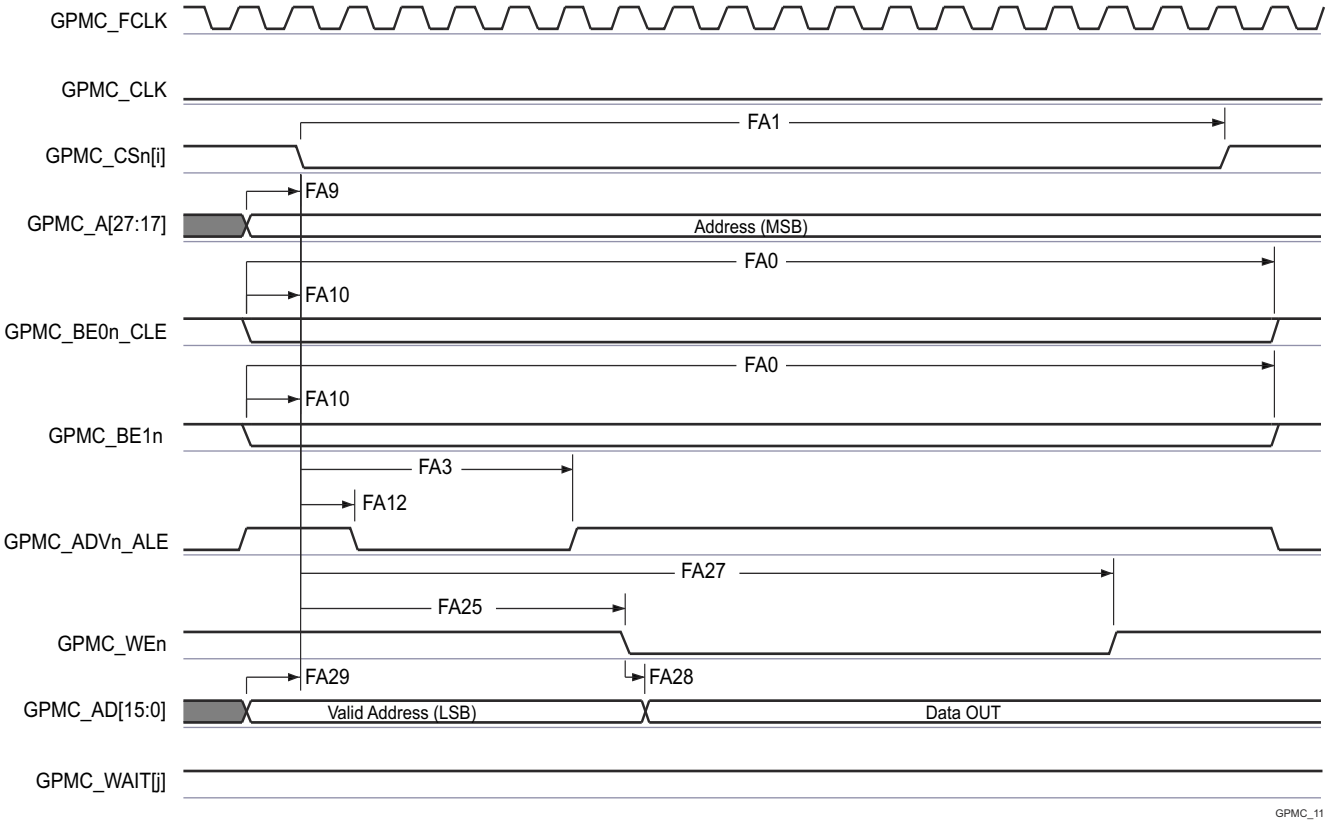

GPMC\_11

A. In GPMC\_CS*n*[*i*], *i* is equal to 0, 1, 2 or 3. In GPMC\_WAIT[j], *j* is equal to 0, 1, 2, or 3.

**7-61. GPMC and Multiplexed NOR Flash — Asynchronous Write — Single Word**

### 7.10.5.10.3 GPMC and NAND Flash — Asynchronous Mode

セクション 7.10.5.10.3.1 和 セクション 7.10.5.10.3.2 assume testing over the recommended operating conditions and electrical characteristic conditions below (see 図 7-62 through 図 7-65).

#### 7.10.5.10.3.1 GPMC and NAND Flash Timing Requirements – Asynchronous Mode

NO.		MODE <sup>(4)</sup>	MIN	MAX	UNIT
			133 MHz <sup>(5)</sup>		
GNF12 <sup>(1)</sup>	$t_{acc(d)}$ Access time, input data GPMC_AD[15:0] <sup>(3)</sup>	div_by_1_mode; GPMC_FCLK_MUX; TIMEPARAGRANULARITY_X1		J <sup>(2)</sup>	ns

(1) The GNF12 parameter illustrates the amount of time required to internally sample input data. It is expressed in number of GPMC functional clock cycles. From start of the read cycle and after GNF12 functional clock cycles, input data is internally sampled by the active functional clock edge. The GNF12 value must be stored inside AccessTime register bit field.

(2)  $J = \text{AccessTime} \times (\text{TimeParaGranularity} + 1) \times \text{GPMC\_FCLK}^{(3)}$

(3) GPMC\_FCLK is general-purpose memory controller internal functional clock period in ns.

(4) For div\_by\_1\_mode:

- GPMC\_CONFIG1\_i Register: GPMCFCLKDIVIDER = 0h:  
 – GPMC\_CLK frequency = GPMC\_FCLK frequency
- CTRLMMR\_GPMC\_CLKSEL[1-0] CLK\_SEL = 00 = CPSWHS DIV\_CLKOUT3 = 2000/15 = 133.33 MHz
- GPMC\_CONFIG1\_i Register: TIMEPARAGRANULARITY = 0h = x1 latencies (affecting RD/WRCYCLETIME, RD/WRACCESSTIME, PAGEBURSTACCESSTIME, CSONTIME, CSRD/WROFFTIME, ADVONTIME, ADVRD/WROFFTIME, OEONTIME, OEOFFTIME, WEONTIME, WEOFFTIME, CYCLE2CYCLEDELAY, BUSTURNAROUND, TIMEOUTSTARTVALUE, WRDATAONADMUXBUS)

(5) For 133 MHz:

- CTRLMMR\_GPMC\_CLKSEL[1-0] CLK\_SEL = 00 = MAIN\_PLL0\_HSDIV3\_CLKOUT

#### 7.10.5.10.3.2 GPMC and NAND Flash Switching Characteristics – Asynchronous Mode

NO.	PARAMETER		MODE <sup>(15)</sup>	MIN	MAX	UNIT
				133 MHz <sup>(16)</sup>		
GNF0	$t_{w(wenV)}$	Pulse duration, output write enable GPMC_WEn valid	div_by_1_mode; GPMC_FCLK_MUX; TIMEPARAGRANULARITY_X1	A <sup>(1)</sup>		ns
GNF1	$t_{d(csnV-wenV)}$	Delay time, output chip select GPMC_CS <i>n</i> [ <i>j</i> ] <sup>(13)</sup> valid to output write enable GPMC_WEn valid	div_by_1_mode; GPMC_FCLK_MUX; TIMEPARAGRANULARITY_X1	B <sup>(2)</sup> - 2.55	B <sup>(2)+</sup> 2.65	ns
GNF2	$t_{w(cleH-wenV)}$	Delay time, output lower-byte enable and command latch enable GPMC_BE0 <i>n</i> _CLE high to output write enable GPMC_WEn valid	div_by_1_mode; GPMC_FCLK_MUX; TIMEPARAGRANULARITY_X1	C <sup>(3)</sup> - 2.55	C <sup>(3)+</sup> 2.65	ns
GNF3	$t_{w(wenV-dV)}$	Delay time, output data GPMC_AD[15:0] valid to output write enable GPMC_WEn valid	div_by_1_mode; GPMC_FCLK_MUX; TIMEPARAGRANULARITY_X1	D <sup>(4)</sup> - 2.55	D <sup>(4)+</sup> 2.65	ns
GNF4	$t_{w(wenIV-dIV)}$	Delay time, output write enable GPMC_WEn invalid to output data GPMC_AD[15:0] invalid	div_by_1_mode; GPMC_FCLK_MUX; TIMEPARAGRANULARITY_X1	E <sup>(5)</sup> - 2.55	E <sup>(5)+</sup> 2.65	ns
GNF5	$t_{w(wenIV-cleIV)}$	Delay time, output write enable GPMC_WEn invalid to output lower-byte enable and command latch enable GPMC_BE0 <i>n</i> _CLE invalid	div_by_1_mode; GPMC_FCLK_MUX; TIMEPARAGRANULARITY_X1	F <sup>(6)</sup> - 2.55	F <sup>(6)+</sup> 2.65	ns

NO.	PARAMETER		MODE <sup>(15)</sup>	MIN	MAX	UNIT
				133 MHz <sup>(16)</sup>		
GNF6	$t_{w(wenIV-CSn[i])}$	Delay time, output write enable GPMC_WEn invalid to output chip select GPMC_CS <i>n</i> [ <i>i</i> ] <sup>(13)</sup> invalid	div_by_1_mode; GPMC_FCLK_MUX; TIMEPARAGRANULARITY_X1	G <sup>(7)</sup> - 2.55	G <sup>(7)+</sup> 2.65	ns
GNF7	$t_{w(aleH-wenV)}$	Delay time, output address valid and address latch enable GPMC_ADV <i>n</i> _ALE high to output write enable GPMC_WEn valid	div_by_1_mode; GPMC_FCLK_MUX; TIMEPARAGRANULARITY_X1	C <sup>(3)</sup> - 2.55	C <sup>(3)+</sup> 2.65	ns
GNF8	$t_{w(wenIV-aleIV)}$	Delay time, output write enable GPMC_WEn invalid to output address valid and address latch enable GPMC_ADV <i>n</i> _ALE invalid	div_by_1_mode; GPMC_FCLK_MUX; TIMEPARAGRANULARITY_X1	F <sup>(6)</sup> - 2.55	F <sup>(6)+</sup> 2.65	ns
GNF9	$t_{c(wen)}$	Cycle time, write	div_by_1_mode; GPMC_FCLK_MUX; TIMEPARAGRANULARITY_X1		H <sup>(8)</sup>	ns
GNF10	$t_{d(csnV-oenV)}$	Delay time, output chip select GPMC_CS <i>n</i> [ <i>i</i> ] <sup>(13)</sup> valid to output enable GPMC_OEn_RE <i>n</i> valid	div_by_1_mode; GPMC_FCLK_MUX; TIMEPARAGRANULARITY_X1	I <sup>(9)</sup> - 2.55	I <sup>(9)+</sup> 2.65	ns
GNF13	$t_{w(oenV)}$	Pulse duration, output enable GPMC_OEn_RE <i>n</i> valid	div_by_1_mode; GPMC_FCLK_MUX; TIMEPARAGRANULARITY_X1		K <sup>(10)</sup>	ns
GNF14	$t_{c(oen)}$	Cycle time, read	div_by_1_mode; GPMC_FCLK_MUX; TIMEPARAGRANULARITY_X1		L <sup>(11)</sup>	ns
GNF15	$t_{w(oenIV-CSn[i])}$	Delay time, output enable GPMC_OEn_RE <i>n</i> invalid to output chip select GPMC_CS <i>n</i> [ <i>i</i> ] <sup>(13)</sup> invalid	div_by_1_mode;	M <sup>(12)</sup> - 2.55	M <sup>(12)+</sup> 2.65	ns

- (1)  $A = (WEOffTime - WEOnTime) \times (TimeParaGranularity + 1) \times GPMC\_FCLK^{(14)}$   
(2)  $B = ((WEOnTime - CSOnTime) \times (TimeParaGranularity + 1) + 0.5 \times (WEEExtraDelay - CSEExtraDelay)) \times GPMC\_FCLK^{(14)}$   
(3)  $C = ((WEOnTime - ADVOnTime) \times (TimeParaGranularity + 1) + 0.5 \times (WEEExtraDelay - ADVExtraDelay)) \times GPMC\_FCLK^{(14)}$   
(4)  $D = (WEOnTime \times (TimeParaGranularity + 1) + 0.5 \times WEEExtraDelay) \times GPMC\_FCLK^{(14)}$   
(5)  $E = ((WrCycleTime - WEOffTime) \times (TimeParaGranularity + 1) - 0.5 \times WEEExtraDelay) \times GPMC\_FCLK^{(14)}$   
(6)  $F = ((ADVWrOffTime - WEOffTime) \times (TimeParaGranularity + 1) + 0.5 \times (ADVExtraDelay - WEEExtraDelay)) \times GPMC\_FCLK^{(14)}$   
(7)  $G = ((CSWrOffTime - WEOffTime) \times (TimeParaGranularity + 1) + 0.5 \times (CSEExtraDelay - WEEExtraDelay)) \times GPMC\_FCLK^{(14)}$   
(8)  $H = WrCycleTime \times (1 + TimeParaGranularity) \times GPMC\_FCLK^{(14)}$   
(9)  $I = ((OEOffTime - CSOnTime) \times (TimeParaGranularity + 1) + 0.5 \times (OEEExtraDelay - CSEExtraDelay)) \times GPMC\_FCLK^{(14)}$   
(10)  $K = (OEOffTime - OEOnTime) \times (1 + TimeParaGranularity) \times GPMC\_FCLK^{(14)}$   
(11)  $L = RdCycleTime \times (1 + TimeParaGranularity) \times GPMC\_FCLK^{(14)}$   
(12)  $M = ((CSRdOffTime - OEOffTime) \times (TimeParaGranularity + 1) + 0.5 \times (CSEExtraDelay - OEEExtraDelay)) \times GPMC\_FCLK^{(14)}$   
(13) In GPMC\_CS*n*[*i*], *i* is equal to 0, 1, 2 or 3.  
(14) GPMC\_FCLK is general-purpose memory controller internal functional clock period in ns.  
(15) For div\_by\_1\_mode:

- GPMC\_CONFIG1\_i Register: GPMCFCLKDIVIDER = 0h:  
– GPMC\_CLK frequency = GPMC\_FCLK frequency

For GPMC\_FCLK\_MUX:

- CTRLMMR\_GPMC\_CLKSEL[1-0] CLK\_SEL = 00 = CPSWHSIDIV\_CLKOUT3 = 2000/15 = 133.33 MHz

For TIMEPARAGRANULARITY\_X1:

- GPMC\_CONFIG1\_i Register: TIMEPARAGRANULARITY = 0h = x1 latencies (affecting RD/WRCYCLETIME, RD/WRACCESSTIME, PAGEBURSTACCESSTIME, CSONTIME, CSRd/WROFFTIME, ADVONTIME, ADVRD/WROFFTIME, OEONTIME, OEOFFTIME, WEONTIME, WEOFFTIME, CYCLE2CYCLEDELAY, BUSTURNAROUND, TIMEOUTSTARTVALUE, WRDATAONADMUXBUS)

(16) For 133 MHz:

- CTRLMMR\_GPMC\_CLKSEL[1-0] CLK\_SEL = 00 = MAIN\_PLL0\_HSDIV3\_CLKOUT

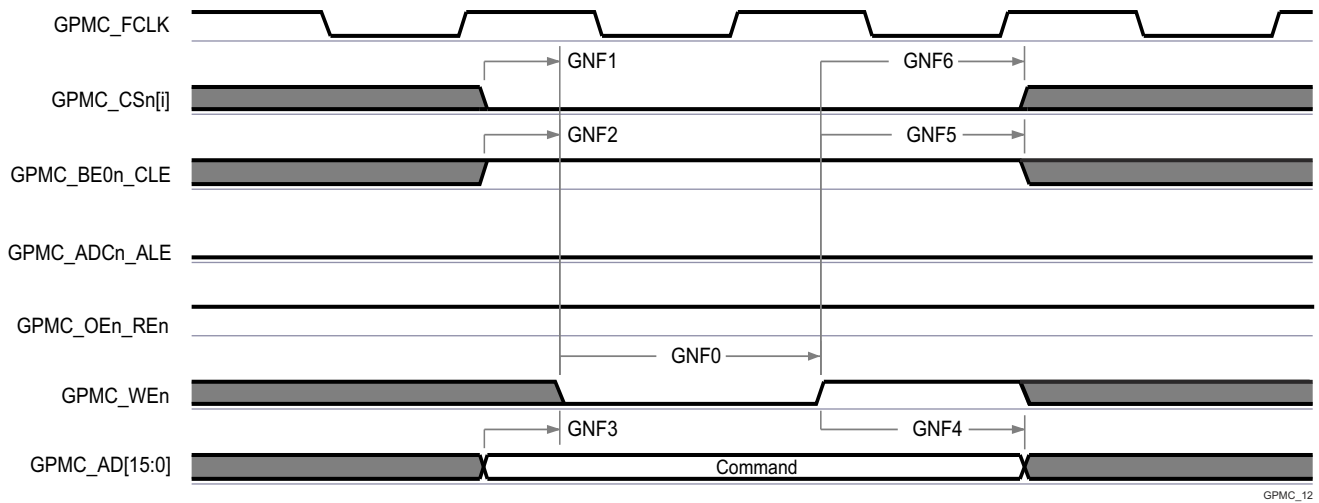

GPMC\_12

A. In GPMC\_CS<sub>n</sub>[i], i is equal to 0, 1, 2 or 3.

7-62. GPMC and NAND Flash — Command Latch Cycle

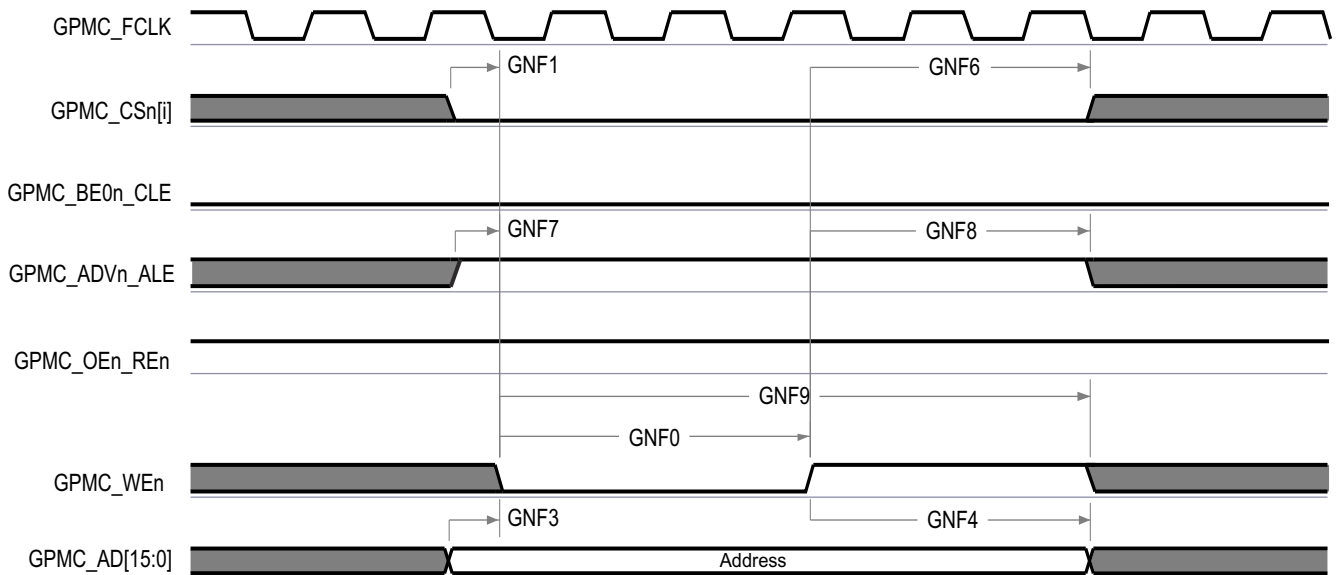

GPMC\_13

A. In GPMC\_CS<sub>n</sub>[i], i is equal to 0, 1, 2 or 3.

7-63. GPMC and NAND Flash — Address Latch Cycle

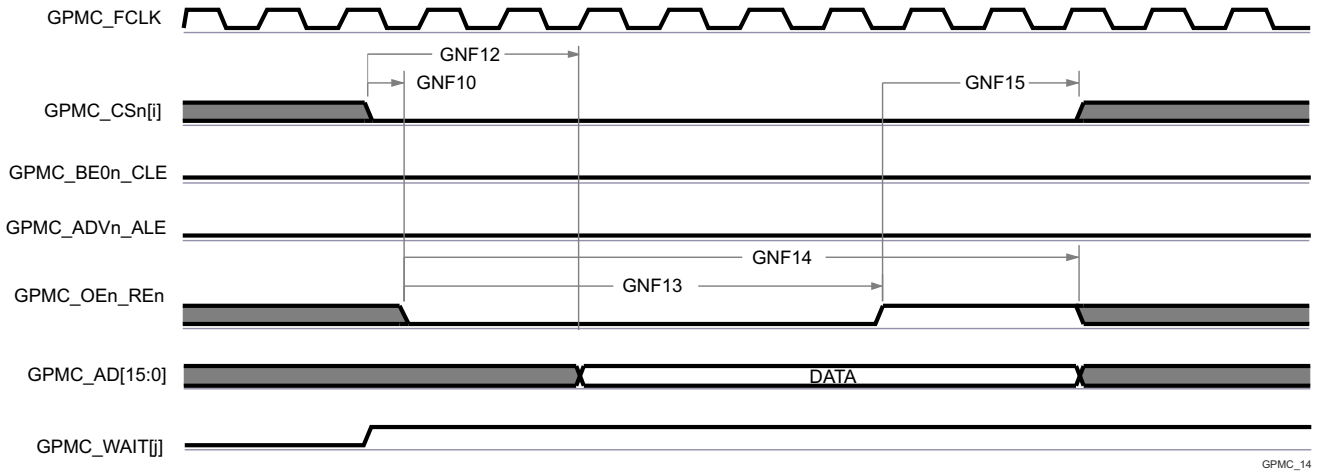

GPMC\_14

- A. GNF12 parameter illustrates amount of time required to internally sample input data. It is expressed in number of GPMC functional clock cycles. From start of read cycle and after GNF12 functional clock cycles, input data will be internally sampled by active functional clock edge. GNF12 value must be stored inside AccessTime register bits field.
- B. GPMC\_FCLK is an internal clock (GPMC functional clock) not provided externally.
- C. In GPMC\_CSn[i], i is equal to 0, 1, 2 or 3. In GPMC\_WAIT[j], j is equal to 0, 1, 2, or 3.

图 7-64. GPMC and NAND Flash — Data Read Cycle

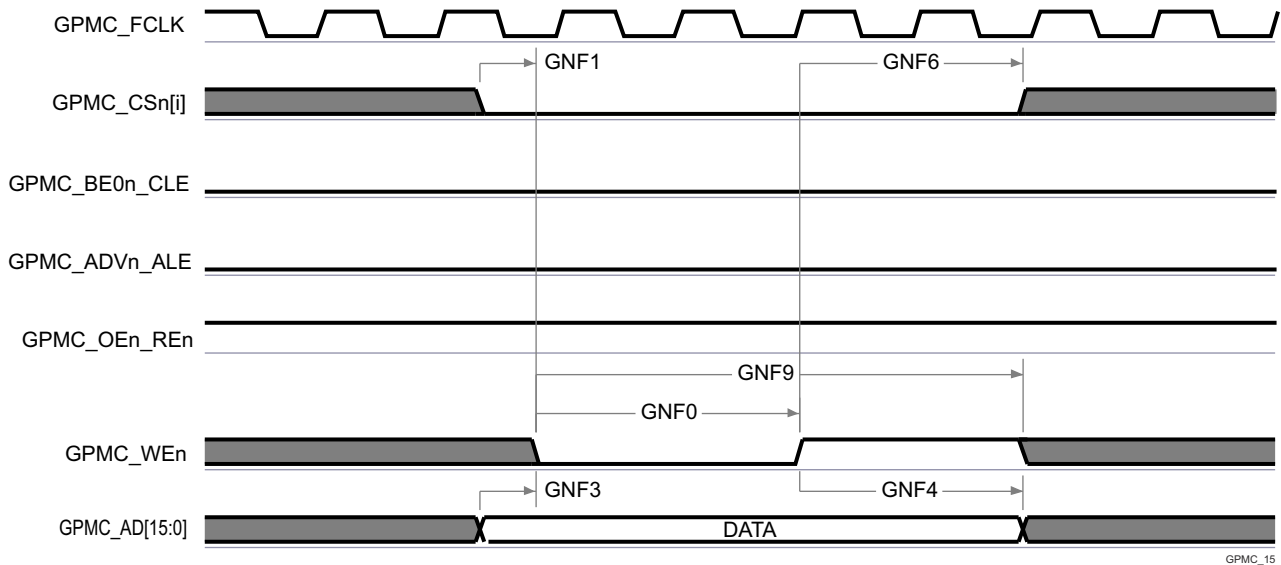

GPMC\_15

- A. In GPMC\_CSn[i], i is equal to 0, 1, 2 or 3.

图 7-65. GPMC and NAND Flash — Data Write Cycle

For more information, see *Enhanced Pulse Width Modulation (EPWM) Module* section in *Peripherals* chapter in the device TRM.

#### 7.10.5.10.4 GPMC0 IOSET

表 7-40 present the specific groupings of signals (IOSET) for use with GPMC0.

表 7-40. GPMC0 IOSET

Signals	IOSET1		IOSET2	
	BALL NAME	MUX	BALL NAME	MUX
GPMC0_WAIT2	MDIO0_MDC	8	MDIO0_MDC	8
GPMC0_BE1n	PRG1_PRU0_GPO0	8	RGMII6_RD1	8

表 7-40. GPMC0 IOSET (continued)

Signals	IOSET1		IOSET2	
	BALL NAME	MUX	BALL NAME	MUX
GPMC0_WAIT0	PRG1_PRU0_GPO1	8	PRG1_PRU0_GPO1	8
GPMC0_WAIT1	PRG1_PRU0_GPO2	8	PRG1_PRU0_GPO2	8
GPMC0_DIR	PRG1_PRU0_GPO3	8	PRG1_PRU0_GPO3	8
GPMC0_CS <sub>n</sub> 2	PRG1_PRU0_GPO4	8	PRG1_PRU0_GPO4	8
GPMC0_WE <sub>n</sub>	PRG1_PRU0_GPO5	8	PRG1_PRU0_GPO5	8
GPMC0_CS <sub>n</sub> 3	PRG1_PRU0_GPO6	8	PRG1_PRU0_GPO6	8
GPMC0_OE <sub>n</sub> RE <sub>n</sub>	PRG1_PRU0_GPO8	8	PRG1_PRU0_GPO8	8
GPMC0_ADV <sub>n</sub> ALE	PRG1_PRU0_GPO9	8	PRG1_PRU0_GPO9	8
GPMC0_BE <sub>0n</sub> CLE	PRG1_PRU0_GPO10	8	PRG1_PRU0_GPO10	8
GPMC0_WP <sub>n</sub>	PRG1_PRU1_GPO5	8	PRG1_PRU1_GPO5	8
GPMC0_CS <sub>n</sub> 1	PRG1_PRU1_GPO8	8	PRG1_PRU1_GPO8	8
GPMC0_CS <sub>n</sub> 0	PRG1_PRU1_GPO9	8	PRG1_PRU1_GPO9	8
GPMC0_CLKOUT	PRG1_PRU1_GPO10	8	PRG1_PRU1_GPO10	8
GPMC0_AD0	PRG0_PRU0_GPO5	8	PRG0_PRU0_GPO5	8
GPMC0_AD1	PRG0_PRU0_GPO7	8	PRG0_PRU0_GPO7	8
GPMC0_AD2	PRG0_PRU0_GPO8	8	PRG0_PRU0_GPO8	8
GPMC0_AD3	PRG0_PRU0_GPO9	8	PRG0_PRU0_GPO9	8
GPMC0_AD4	PRG0_PRU0_GPO10	8	PRG0_PRU0_GPO10	8
GPMC0_AD5	PRG0_PRU0_GPO17	8	PRG0_PRU0_GPO17	8
GPMC0_AD6	PRG0_PRU0_GPO18	8	PRG0_PRU0_GPO18	8
GPMC0_AD7	PRG0_PRU0_GPO19	8	PRG0_PRU0_GPO19	8
GPMC0_AD8	PRG0_PRU1_GPO5	8	PRG0_PRU1_GPO5	8
GPMC0_AD9	PRG0_PRU1_GPO7	8	PRG0_PRU1_GPO7	8
GPMC0_AD10	PRG0_PRU1_GPO8	8	PRG0_PRU1_GPO8	8
GPMC0_AD11	PRG0_PRU1_GPO9	8	PRG0_PRU1_GPO9	8
GPMC0_AD12	PRG0_PRU1_GPO10	8	PRG0_PRU1_GPO10	8
GPMC0_AD13	PRG0_PRU1_GPO17	8	PRG0_PRU1_GPO17	8
GPMC0_AD14	PRG0_PRU1_GPO18	8	PRG0_PRU1_GPO18	8
GPMC0_AD15	PRG0_PRU1_GPO19	8	PRG0_PRU1_GPO19	8
GPMC0_A0	PRG0_MDIO0_MDC	8	PRG0_MDIO0_MDC	8
GPMC0_A1	RGMII5_TX_CTL	8	RGMII5_TX_CTL	8
GPMC0_A2	RGMII5_RX_CTL	8	RGMII5_RX_CTL	8
GPMC0_A3	RGMII5_TD3	8	RGMII5_TD3	8
GPMC0_A4	RGMII5_TD2	8	RGMII5_TD2	8
GPMC0_A5	RGMII5_TD1	8	RGMII5_TD1	8
GPMC0_A6	RGMII5_TD0	8	RGMII5_TD0	8
GPMC0_A7	RGMII5_TXC	8	RGMII5_TXC	8
GPMC0_A8	RGMII5_RXC	8	RGMII5_RXC	8
GPMC0_A9	RGMII5_RD3	8	RGMII5_RD3	8
GPMC0_A10	RGMII5_RD2	8	RGMII5_RD2	8
GPMC0_A11	RGMII5_RD1	8	RGMII5_RD1	8
GPMC0_A12	RGMII5_RD0	8	RGMII5_RD0	8
GPMC0_A13	RGMII6_TX_CTL	8	RGMII6_TX_CTL	8
GPMC0_A14	RGMII6_RX_CTL	8	RGMII6_RX_CTL	8

ADVANCE INFORMATION



表 7-40. GPMC0 IOSET (continued)

Signals	IOSET1		IOSET2	
	BALL NAME	MUX	BALL NAME	MUX
GPMC0_A15	RGMII6_TD3	8	RGMII6_TD3	8
GPMC0_A16	RGMII6_TD2	8	RGMII6_TD2	8
GPMC0_A17	RGMII6_TD1	8	RGMII6_TD1	8
GPMC0_A18	RGMII6_TD0	8	RGMII6_TD0	8
GPMC0_A19	RGMII6_TXC	8	RGMII6_TXC	8
GPMC0_A20	RGMII6_RXC	8	RGMII6_RXC	8
GPMC0_A21	RGMII6_RD3	8	RGMII6_RD3	8
GPMC0_A22	RGMII6_RD2	8	RGMII6_RD2	8
GPMC0_A23	PRG0_PRU1_GPO2	8	PRG0_PRU1_GPO2	8
GPMC0_A24	PRG0_PRU1_GPO4	8	PRG0_PRU1_GPO4	8
GPMC0_A25	PRG0_PRU1_GPO6	8	PRG0_PRU1_GPO6	8
GPMC0_A26	PRG0_PRU1_GPO11	8	PRG0_PRU1_GPO11	8
GPMC0_A27	PRG0_MDIO0_MDIO	8	PRG0_MDIO0_MDIO	8
GPMC0_WAIT3	MDIO0_MDIO	8	MDIO0_MDIO	8

### 7.10.5.11 HyperBus

For more details about features and additional description information on the device HyperBus, see the corresponding sections within [Signal Descriptions](#) and [Detailed Description](#).

セクション 7.10.5.11, セクション 7.10.5.11.2, and セクション 7.10.5.11.3 assume testing over the recommended operating conditions and electrical characteristic conditions (see [図 7-66](#), [図 7-67](#), and [図 7-68](#)).

表 7-41 represents HyperBus timing conditions.

表 7-41. HyperBus Timing Conditions

PARAMETER	DESCRIPTION	MIN	MAX	UNIT
<b>INPUT CONDITIONS</b>				
SR <sub>i</sub>	Input slew rate	2	5	V/ns
<b>OUTPUT CONDITIONS</b>				
C <sub>L</sub>	Output load capacitance			

#### 7.10.5.11.1 Timing Requirements for HyperBus

NO.	PARAMETER	DESCRIPTION	MIN	MAX	UNIT
D1	t <sub>w</sub> (RESETn)	Pulse width, RESETn	200		ns
D2	t <sub>w</sub> (csL)	Pulse width, Chip Select	1000		ns
D3	t <sub>d</sub> (RESETnH-csL)	Delay time, RESETn inactive to CSn active	200.34		ns
D4	t <sub>d</sub> (csL-RWDSL)	Delay time, CSn active to RWDS falling	115		ns

#### 7.10.5.11.2 HyperBus 166 MHz Switching Characteristics

NO.	PARAMETER	DESCRIPTION	MIN	MAX	UNIT
D5	t <sub>skn</sub> (rwdsX-dV)	Input skew, RWDS transitioning to D0:D7 valid	-0.46	0.46	ns
D6	t <sub>c</sub> (clk/clkn)	CLK period, CLK/CLKn	6		ns
D7	t <sub>w</sub> (clk/clkn)	Pulse width, CLK/CLKn	2.7		ns
D8	t <sub>w</sub> (csIV)	Pulse width, CS0 invalid between operations	6		ns
D9	t <sub>d</sub> (clkH-csL)	Delay time, CS0 active to CLK rising/ CLKn falling		-3.34	ns
D10	t <sub>d</sub> (clkL[LE]-csH)	Delay time, last falling CLK/ rising CLKn edge to CS0 inactive	0.41		ns

NO.	PARAMETER	DESCRIPTION	MIN	MAX	UNIT
D11	$t_{d(\text{clkX-rwdsV})}$	Delay time, CLK transition to RWDS valid	1.01	2.08	ns
D12	$t_{d(\text{clkX-d}[0:7]V)}$	Delay time, CLK transitioning to D0:D7 valid	0.84	2.17	ns

### 7.1.0.5.11.3 HyperBus 100 MHz Switching Characteristics

NO.	PARAMETER	DESCRIPTION	MIN	MAX	UNIT
LFD5	$t_{\text{skn}(\text{rwdsX-dV})}$	Input skew, RWDS transitioning to D0:D7 valid	-0.81	0.81	ns
LFD6	$t_{c(\text{clk})}$	CLK period, CLK	10		ns
LFD7	$t_{w(\text{clk})}$	Pulse width, CLK	4.75		ns
LFD8	$t_{w(\text{csIV})}$	Pulse width, CS0 invalid between operations	10		ns
LFD9	$t_{d(\text{clkH-csL})}$	Delay time, CS0 active to CLK rising		-3.51	ns
LFD10	$t_{d(\text{clkL}[LE]-\text{csH})}$	Delay time, last falling CLK edge to CS0 inactive	0.51		ns
LFD11	$t_{d(\text{clkX-rwdsV})}$	Delay time, CLK transition to RWDS valid	1.51	3.49	ns
LFD12	$t_{d(\text{clkX-d}[0:7]V)}$	Delay time, CLK transitioning to D0:D7 valid	1.34	3.66	ns

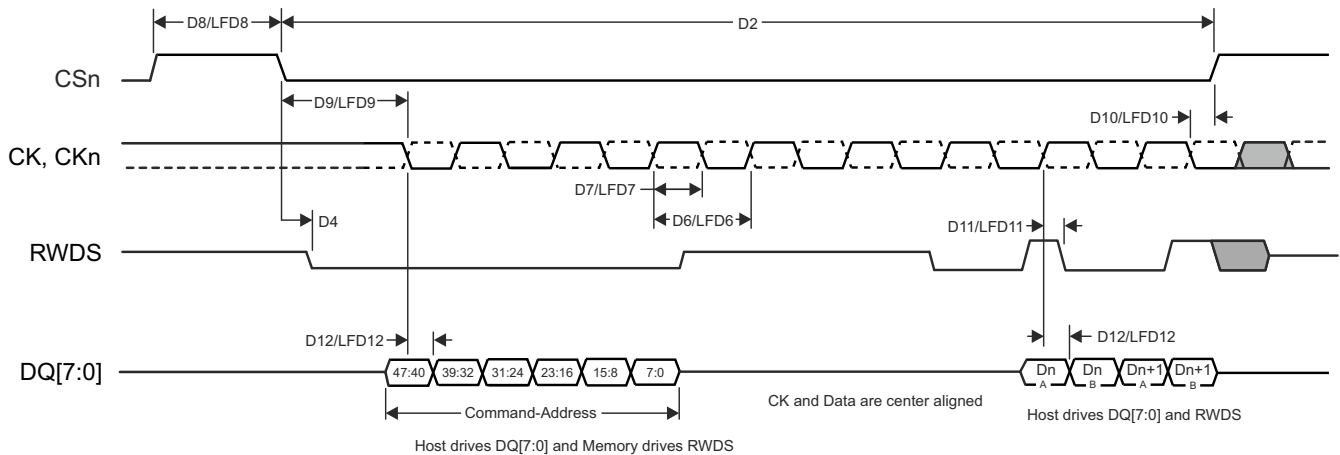

HYPERBUS\_TIMING\_01

7-66. HyperBus Timing Diagrams – Transmitter Mode

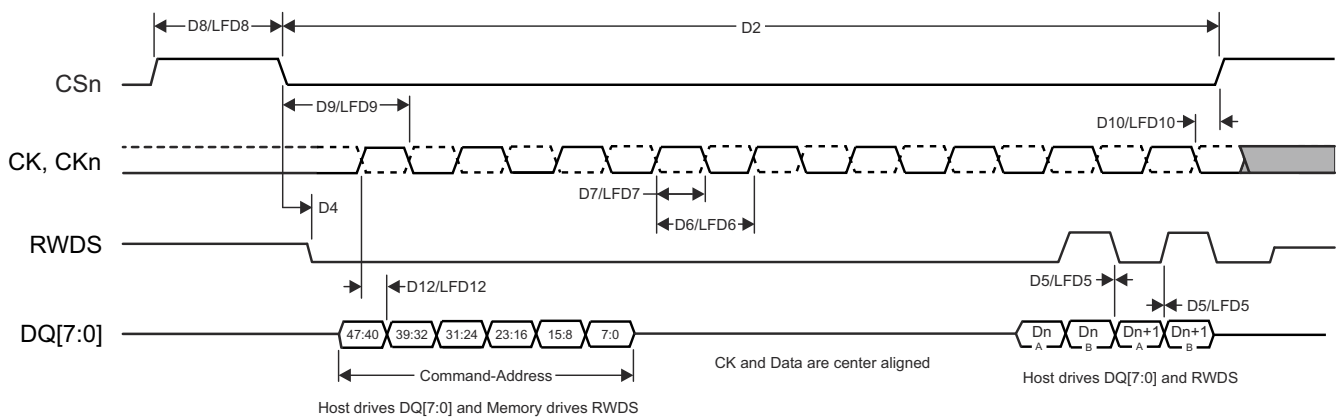

HYPERBUS\_TIMING\_02

7-67. HyperBus Timing Diagrams – Receiver Mode

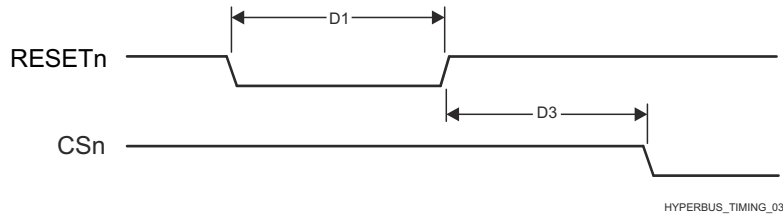

**7-68. HyperBus Timing Diagrams – Reset**

For more information, see *HyperBus Interface* section in *Peripherals* chapter in the device TRM.

### 7.10.5.12 I2C

The device contains **several** multicontroller Inter-Integrated Circuit (I2C) controllers. Each I2C controller was designed to be compliant to the Philips I2C-bus™ specification version 2.1. However, the device **IO Buffers** are not fully compliant to the I2C electrical specification. **Some I2C instances use the LVCMOS Buffer Type, while other instances use the I2S OD FS Buffer type. See the Pin Attributes table to determine the IO Buffer Type used for each I2C instance on this device.** The I2C speeds supported and exceptions are described per **IO Buffer Type** below:

- I2C instances that use the LVCMOS buffer type
  - Speeds:
    - Standard-mode (up to 100 Kbits/s)
      - 1.8 V
      - 3.3 V
    - Fast-mode (up to 400 Kbits/s)
      - 1.8 V
      - 3.3 V
  - Exceptions:
    - The IOs associated with these ports are not compliant to the fall time requirements defined in the I2C specification because they are implemented with higher performance LVCMOS push-pull IOs that were designed to support other signal functions that could not be implemented with I2C compatible IOs. The LVCMOS IOs being used on these ports are connected such they emulate open-drain outputs. This emulation is achieved by forcing a constant low output and disabling the output buffer to enter the Hi-Z state.
    - The I2C specification defines a maximum input voltage  $V_{IH}$  of  $(V_{DD_{max}} + 0.5 V)$ , which exceeds the absolute maximum ratings for the device IOs. The system must be designed to ensure the I2C signals never exceed the limits defined in the [Absolute Maximum Ratings](#) section of this data sheet.
- I2C instances that use the I2C OD FS buffer type
  - Speeds:
    - Standard-mode (up to 100 Kbits/s)
      - 1.8 V
      - 3.3 V
    - Fast-mode (up to 400 Kbits/s)
      - 1.8 V
      - 3.3 V
    - Hs-mode (up to 3.4 Mbit/s)
      - 1.8 V
  - Exceptions:
    - The IOs associated with these ports were not design to support Hs-mode while operating at 3.3 V. So Hs-mode is limited to 1.8-V operation.
    - The rise and fall times of the I2C signals connected to these ports must not exceed a slew rate of 0.8 V/ns (or 8E+7 V/s). This limit is more restrictive than the minimum fall time limits defined in the I2C specification. Therefore, it may be necessary to add additional capacitance to the I2C signals to slow the rise and fall times such that they do not exceed a slew rate of 0.8 V/ns.

- The I2C specification defines a maximum input voltage  $V_{IH}$  of  $(V_{DD_{max}} + 0.5 V)$ , which exceeds the absolute maximum ratings for the device IOs. The system must be designed to ensure the I2C signals never exceed the limits defined in the [Absolute Maximum Ratings](#) section of this data sheet.

Refer to the Philips I2C-bus specification version 2.1 for timing details.

For more details about features and additional description information on the device Inter-Integrated Circuit, see the corresponding subsections within [セクション 6.3](#) and *Detailed Description*.

### 7.10.5.13 I3C

For more details about features and additional description information on the device Inter-Integrated Circuit, see the corresponding sections within [Signal Descriptions](#), *Signal Descriptions* and *Detailed Description*.

表 7-42, 表 7-43, 図 7-69, 表 7-44, and 図 7-70 assume testing over the recommended operating conditions and electrical characteristic conditions.

**表 7-42. I3C Open Drain Timing Conditions**

PARAMETER		MIN	MAX	UNIT
<b>INPUT CONDITIONS</b>				
$SR_I$	Input slew rate	0.2276	5	V/ns
<b>OUTPUT CONDITIONS</b>				
$C_L$	Output load capacitance		50	pF

**表 7-43. I3C Open Drain Timing Parameters**

NO.	PARAMETER	DESCRIPTION	MODE	MIN	MAX	UNIT
D1	$t_{LOW\_OD}$	Low Period of SCL Clock	Controller	200		ns
	$t_{DIG\_OD\_L}$			$t_{LOW\_OD\ MIN} + t_{FDA\_OD\ MIN}$		ns
D2	$t_{HIGH}$	High Period of SCL Clock	Controller		41	ns
	$t_{DIG\_H}$			$t_{HIGH} + t_{CF}$		ns
D3	$t_{rDA\_OD}$	Fall Time of SDA Signal	Controller, Target	$t_{CF}$	12	ns
D4	$t_{SU\_OD}$	SDA Data Setup Time During Open Drain Mode	Controller, Target	3		ns
D5	$t_{CAS}$	Clock After START (S) Condition	Controller, ENTAS0	38.4	1000	ns
			Controller, ENTAS1	38.4	100000	ns
			Controller, ENTAS2	38.4	2000000	ns
			Controller, ENTAS3	38.4	50000000	ns
D6	$t_{CBP}$	Clock Before STOP (P) Condition	Controller	$t_{CAS\ MIN} / 2$		ns
D7	$t_{MMOVEOVLAP}$	Current Controller to Secondary Controller Overlap time during handoff	Controller	$t_{DIG\_OD\_L\ min}$		ns
D8	$t_{AVAL}$	Bus Available Condition	Controller	1000		ns
D9	$t_{IDLE}$	Bus Idle Condition	Controller	1000000		ns
D10	$t_{MMLOCK}$	Time Interval Where New Controller Not Driving SDA Low	Controller	$t_{AVAL\ min}$		ns

- This is approximately equal to  $t_{LOW\ min} + t_{DS\_OD\ min} + t_{rDA\_OD\ typ} + t_{SU\_O\ min}$ .
- The Controller may use a shorter Low period if the Controller knows that this is safe, when SDA is already above  $V_{IH}$ .
- Based on  $t_{SPIKE}$ , rise and fall times, and interconnect.

- This maximum High period may be exceeded when the signals can be safely seen by Legacy I2C Devices, and/or in consideration of the interconnect (for example: a short Bus).
- On a Legacy Bus where I2C Devices need to see Start, the  $t_{CAS}$  Min value is further constrained.
- Targets that do not support the optional ENTASx CCCs shall use the  $t_{CAS}$  Max value shown for ENTAS3.
- On a Mixed Bus with Fm Legacy I2C Devices,  $t_{AVAL}$  is 300ns shorter than the Fm Bus Free Condition time ( $t_{BUF}$ ).



图 7-69. I3C Open Drain Timing

表 7-44. I3C Push-Pull Timing Parameters for SDR and HDR-DDR Modes

NO.	PARAMETER	DESCRIPTION	MODE	MIN	MAX	UNIT
D1	$f_{SCL}$	SCL Clock Period	Controller	80	100000	ns
D2	$t_{LOW}$	SCL Clock Low Period	Controller	24		ns
	$t_{DIG\_L}$			32		ns
D3	$t_{HIGH\_MIXED}$	SCL Clock High Period of Mixed Bus (Mixed Bus Topology Not Supported)	Controller	24		ns
	$t_{DIG\_H\_MIXED}$			32	45	ns
D4	$t_{HIGH}$	SCL Clock High Period	Controller	24		ns
	$t_{DIG\_H}$			32		ns
D5	$t_{SCO}$	Clock in to Data Out for Target	Target	12		ns
D6	$t_{CR}$	SCL Clock Rise Time	Controller	$150 \times 1 / f_{SCL}$	60	ns
D7	$t_{CF}$	SCL Clock Fall Time	Controller	$150 \times 1 / f_{SCL}$	60	ns
D8	$t_{HD\_PP}$	SDA Signal Data Hold in Push Pull Mode	Controller	$t_{CR} + 3$ and $t_{CF} + 3$		ns
			Target	0		ns
D9	$t_{SU\_PP}$	SDA Signal Data Setup In Push-Pull Mode	Controller, Target	3		ns
D10	$t_{CASr}$	Clock After Repeated START (Sr)	Controller	$t_{CAS\ MIN}$		ns
D11	$t_{CBSr}$	Clock Before Repeated START (Sr)	Controller	$t_{CAS\ MIN} / 2$		ns

- $f_{SCL} = 1 / (t_{DIG\_L} + t_{DIG\_H})$
- $t_{DIG\_L}$  and  $t_{DIG\_H}$  are the clock Low and High periods as seen at the receiver end of the I3C Bus using  $V_{IL}$  and  $V_{IH}$ .
- When communicating with an I3C Device on a mixed Bus, the  $t_{DIG\_H\_MIXED}$  period must be constrained to make sure that I2C Devices do not interpret I3C signaling as valid I2C signaling.
- As both edges are used, the hold time needs to be satisfied for the respective edges;  $t_{CF} + 3$  for falling edge clocks, and  $t_{CR} + 3$  for rising edge clocks.
- Clock Frequency Minimum 0.01 MHz, Maximum 12.5 MHz

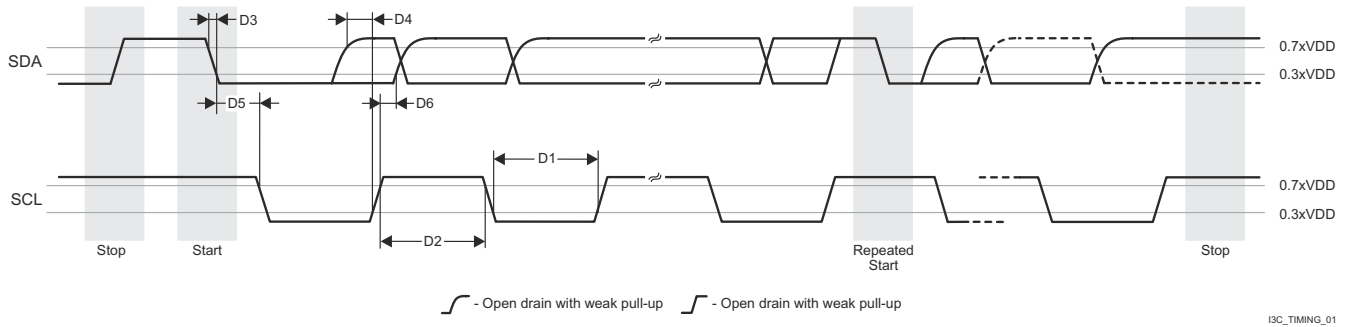

图 7-70. I3C Push-Pull Timing (SDR and HDR-DDR Modes)

7.10.5.14 MCAN

For more details about features and additional description information on the device Controller Area Network Interface, see the corresponding sections within [Signal Descriptions](#) and [Detailed Description](#).

注

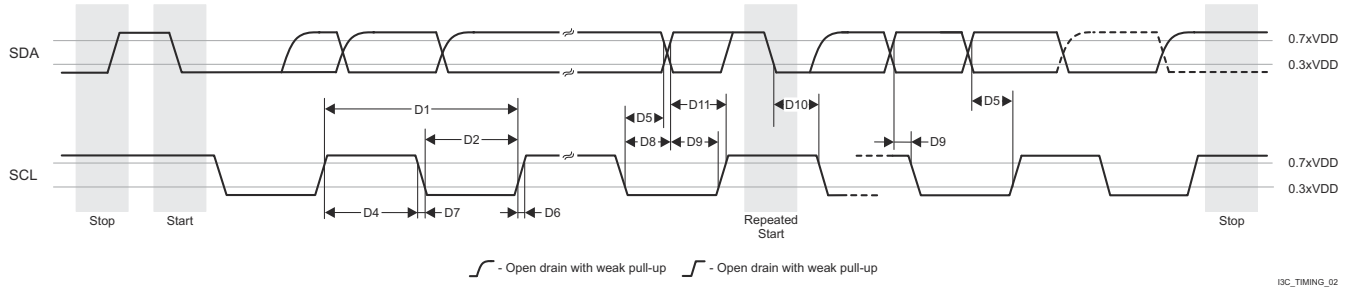
The device has multiple MCAN modules. MCANn is a generic prefix applied to MCAN signal names, where n represents the specific MCAN module.

表 7-45. MCAN Timing Conditions

PARAMETER		MIN	MAX	UNIT
<b>INPUT CONDITIONS</b>				
SR <sub>i</sub>	Input slew rate	2	15	V/ns
<b>OUTPUT CONDITIONS</b>				
C <sub>L</sub>	Output load capacitance	5	20	pF

表 7-46. MCAN Switching Characteristics

NO.	PARAMETER		MIN	MAX	UNIT
MCAN1	t <sub>d(MCAN_TX)</sub>	Delay time, transmit shift register to MCANn_TX pin <sup>(1)</sup>		10	ns
MCAN2	t <sub>d(MCAN_RX)</sub>	Delay time, MCANn_RX pin to receive shift register <sup>(1)</sup>		10	ns

(1) n is [0:13] in MCANn\_\* or [0:1] in MCU\_MCANn\_\*

For more information, see *Controller Area Network (MCAN)* section in *Peripherals* chapter in the device TRM.

### 7.10.5.15 MCASP

For more details about features and additional description information on the device Multichannel Audio Serial Port, see the corresponding sections within [Signal Descriptions](#) and [Detailed Description](#).

表 7-48 and 表 7-71 present timing requirements for MCASP0 to MCASP11.

表 7-47 represents MCASP timing conditions.

**表 7-47. MCASP Timing Conditions**

PARAMETER		MIN	MAX	UNIT
<b>INPUT CONDITIONS</b>				
SR <sub>I</sub>	Input slew rate	0.7	5	V/ns
<b>OUTPUT CONDITIONS</b>				
C <sub>L</sub>	Output load capacitance	1	10	pF
<b>PCB CONNECTIVITY REQUIREMENTS</b>				
t <sub>d</sub> (Trace Delay)	Propagation delay of each trace	100	1100	ps
t <sub>d</sub> (Trace Mismatch Delay)	Propagation delay mismatch across all traces		100	ps

**表 7-48. MCASP Timing Requirements**

NO.			MODE <sup>(1)</sup>	MIN	MAX	UNIT
ASP1	t <sub>c</sub> (AHCLKRX)	Cycle time, MCASP[x]_AHCLKR/X		15.26		ns
ASP2	t <sub>w</sub> (AHCLKRX)	Pulse duration, MCASP[x]_AHCLKR/X high or low		0.5P <sup>(2)</sup> - 1.53		ns
ASP3	t <sub>c</sub> (ACLKRX)	Cycle time, MCASP[x]_ACLKR/X		15.26		ns
ASP4	t <sub>w</sub> (ACLKRX)	Pulse duration, MCASP[x]_ACLKR/X high or low		0.5R <sup>(3)</sup> - 1.53		ns
ASP5	t <sub>su</sub> (AFSRX-ACLKRX)	Setup time, MCASP[x]_AFSR/X input valid before MCASP[x]_ACLKR/X	ACLKR/X int	12.3		ns
			ACLKR/X ext in/out	4		
ASP6	t <sub>h</sub> (ACLKRX-AFSRX)	Hold time, MCASP[x]_AFSR/X input valid after MCASP[x]_ACLKR/X	ACLKR/X int	-1		ns
			ACLKR/X ext in/out	1.6		
ASP7	t <sub>su</sub> (AXR-ACLKRX)	Setup time, MCASP[x]_AXR input valid before MCASP[x]_ACLKR/X	ACLKR/X int	12.3		ns
			ACLKR/X ext in/out	4		
ASP8	t <sub>h</sub> (ACLKRX-AXR)	Hold time, MCASP[x]_AXR input valid after MCASP[x]_ACLKR/X	ACLKR/X int	-1		ns
			ACLKR/X ext in/out	1.6		

- (1) ACLKR internal: ACLKRCTL.CLKRM=1, PDIR.ACLKR = 1  
 ACLKR external input: ACLKRCTL.CLKRM=0, PDIR.ACLKR=0  
 ACLKR external output: ACLKRCTL.CLKRM=0, PDIR.ACLKR=1  
 ACLKX internal: ACLKXCTL.CLKXM=1, PDIR.ACLKX = 1  
 ACLKX external input: ACLKXCTL.CLKXM=0, PDIR.ACLKX=0  
 ACLKX external output: ACLKXCTL.CLKXM=0, PDIR.ACLKX=1
- (2) P = AHCLKR/X period in ns.
- (3) R = ACLKR/X period in ns.

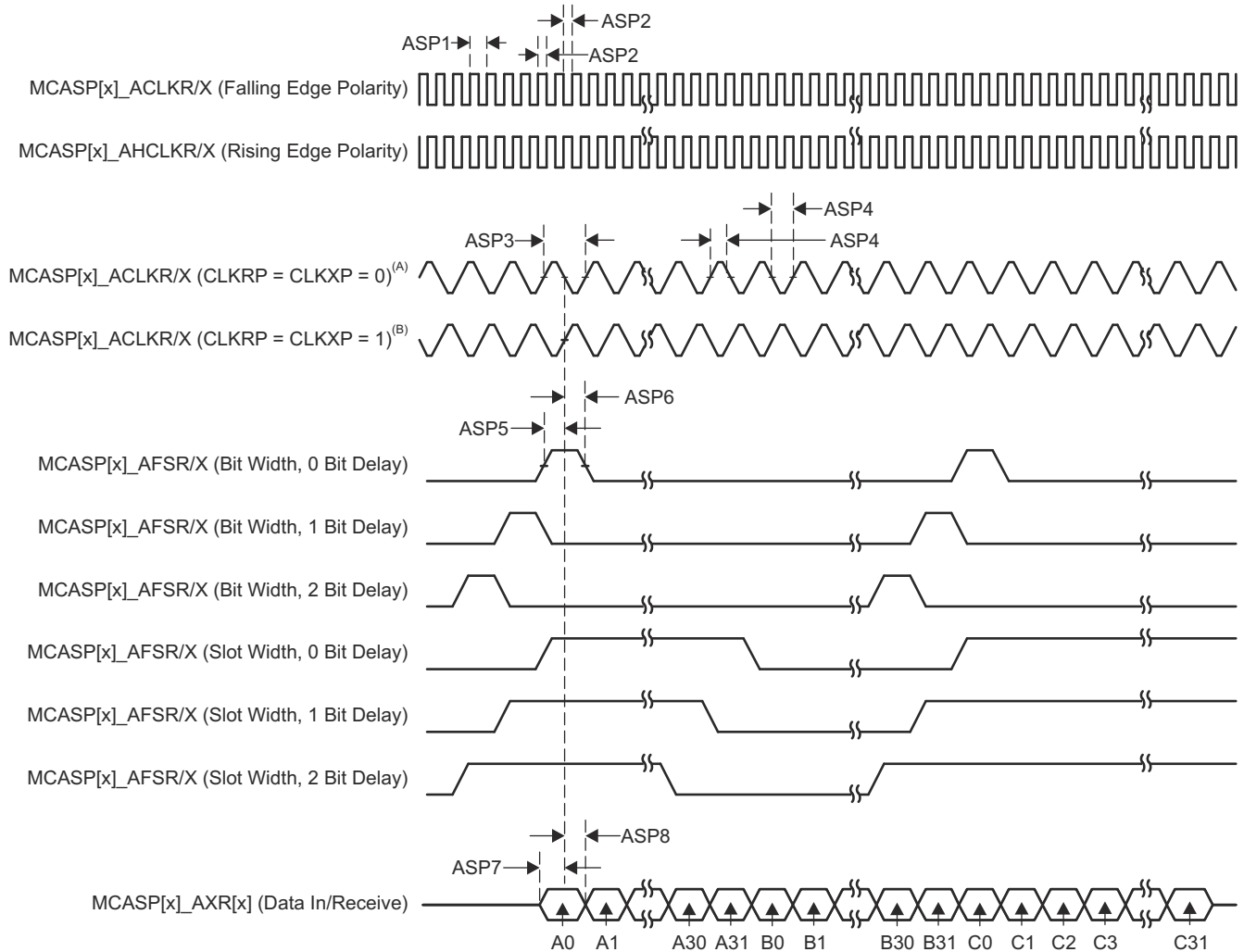

- A. For CLKRP = CLKXP = 0, the MCASP transmitter is configured for rising edge (to shift data out) and the MCASP receiver is configured for falling edge (to shift data in).
- B. For CLKRP = CLKXP = 1, the MCASP transmitter is configured for falling edge (to shift data out) and the MCASP receiver is configured for rising edge (to shift data in).

**7-71. MCASP Input Timing**



表 7-49 和 图 7-72 present switching characteristics over recommended operating conditions for MCASP0 to MCASP11.

**表 7-49. MCASP Switching Characteristics**

NO.	PARAMETER	DESCRIPTION	MODE <sup>(1)</sup>	MIN	MAX	UNIT
ASP9	$t_c(\text{AHCLKRX})$	Cycle time, MCASP[x]_AHCLKR/X		20		ns
ASP10	$t_w(\text{AHCLKRX})$	Pulse duration, MCASP[x]_AHCLKR/X high or low		0.5P <sup>(2)</sup> - 2		ns
ASP11	$t_c(\text{ACLKRX})$	Cycle time, MCASP[x]_ACLKR/X		20		ns
ASP12	$t_w(\text{ACLKRX})$	Pulse duration, MCASP[x]_ACLKR/X high or low		0.5R <sup>(3)</sup> - 2		ns
ASP13	$t_d(\text{ACLKRX-AFSRX})$	Delay time, MCASP[x]_ACLKR/X transmit edge to MCASP[x]_AFSR/X output valid	ACLKR/X int	0	7.25	ns
			ACLKR/X ext in/out	-15.28	12.84	
ASP14	$t_d(\text{ACLKX-AXR})$	Delay time, MCASP[x]_ACLKX transmit edge to MCASP[x]_AXR output valid	ACLKR/X int	0	7.25	ns
			ACLKR/X ext in/out	-15.28	12.84	
ASP15	$t_{dis}(\text{ACLKX-AXR})$	Disable time, MCASP[x]_ACLKX transmit edge to MCASP[x]_AXR output high impedance	ACLKR/X int	0	7.25	ns
			ACLKR/X ext in/out	-14.9	14	

- (1) ACLKR internal: ACLKRCTL.CLKRM=1, PDIR.ACLKR = 1  
 ACLKR external input: ACLKRCTL.CLKRM=0, PDIR.ACLKR=0  
 ACLKR external output: ACLKRCTL.CLKRM=0, PDIR.ACLKR=1  
 ACLKX internal: ACLKXCTL.CLKXM=1, PDIR.ACLKX = 1  
 ACLKX external input: ACLKXCTL.CLKXM=0, PDIR.ACLKX=0  
 ACLKX external output: ACLKXCTL.CLKXM=0, PDIR.ACLKX=1
- (2) P = AHCLKR/X period in ns.
- (3) R = ACLKR/X period in ns.

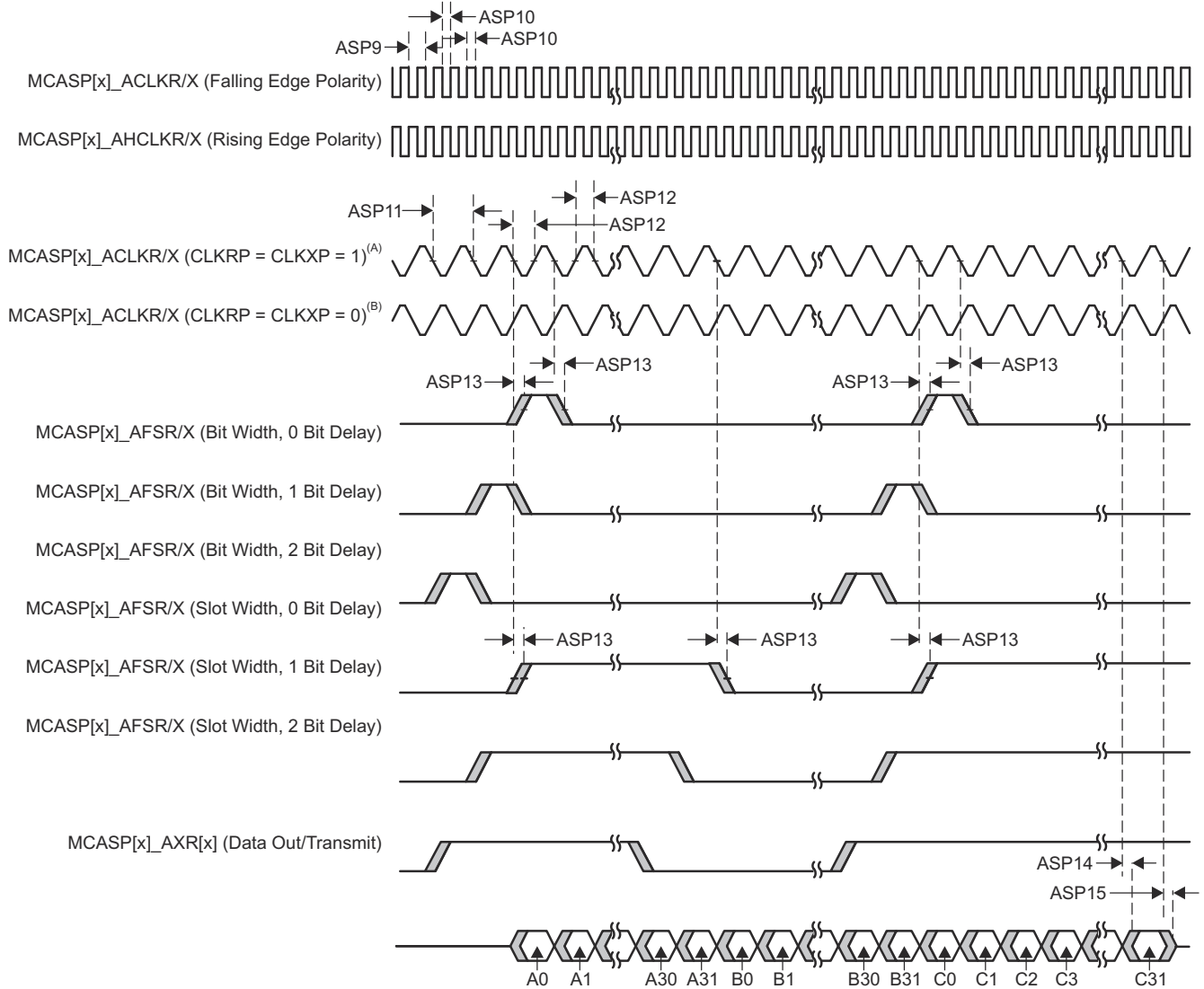

- A. For CLKRP = CLKXP = 1, the MCASP transmitter is configured for falling edge (to shift data out) and the MCASP receiver is configured for rising edge (to shift data in).
- B. For CLKRP = CLKXP = 0, the MCASP transmitter is configured for rising edge (to shift data out) and the MCASP receiver is configured for falling edge (to shift data in).

**7-72. MCASP Output Timing**

For more information, see *Multichannel Audio Serial Port (MCASP)* section in *Peripherals* chapter in the device TRM.

### 7.10.5.16 MCSPI

For more details about features and additional description information on the device Serial Port Interface, see the corresponding sections within [Signal Descriptions](#) and [Detailed Description](#).

For more information, see [Multichannel Serial Peripheral Interface \(MCSPI\)](#) section in [Peripherals](#) chapter in the device TRM.

表 7-50 represents MCSPI timing conditions.

注

The IO timings provided in this section are applicable for all combinations of signals for MCU\_SPI0 and MCU\_SPI1. However, the timings are only valid for MCU\_SPI0 and MCU\_SPI1 if signals within a single IOSET are used. The IOSETs are defined in the 表 7-55 and 表 7-56 tables.

表 7-50. MCSPI Timing Conditions

PARAMETER		MIN	MAX	UNIT	
<b>INPUT CONDITIONS</b>					
SR <sub>I</sub>	Input slew rate	2	8.5	V/ns	
<b>OUTPUT CONDITIONS</b>					
C <sub>L</sub>	Output load capacitance	CLK	6	24	pF
		D[x], CSi	6	12	pF

#### 7.10.5.16.1 MCSPI — Controller Mode

表 7-51, 表 7-73, 表 7-52, and 表 7-74 present timing requirements and switching characteristics for MCSPI – Controller Mode.

表 7-51. MCSPI Timing Requirements - Controller Mode

see 表 7-73

NO.		MIN	MAX	UNIT
SM4	t <sub>su(misoV-spicklV)</sub> Setup time, SPI_D[x] valid before SPI_CLK active edge	2.9		ns
SM5	t <sub>h(spicklV-misoV)</sub> Hold time, SPI_D[x] valid after SPI_CLK active edge	2		ns

表 7-52. MCSPI Switching Characteristics - Controller Mode

see 表 7-74

NO.	PARAMETER	MODE	MIN	MAX	UNIT
SM1	t <sub>c(spickl)</sub> Cycle time, SPI_CLK		20.8		ns
SM2	t <sub>w(spicklL)</sub> Pulse duration, SPI_CLK low		0.5P - 1 <sup>(1)</sup>		ns
SM3	t <sub>w(spicklH)</sub> Pulse duration, SPI_CLK high		0.5P - 1 <sup>(1)</sup>		ns
SM6	t <sub>d(spicklV-simoV)</sub> Delay time, SPI_CLK active edge to SPI_D[x] transition		-2	2	ns
SM7	t <sub>d(csV-simoV)</sub> Delay time, SPI_CSi active edge to SPI_D[x] transition		5		ns
SM8	t <sub>d(csV-spickl)</sub> Delay time, SPI_CSi active to SPI_CLK first edge	PHA = 0 <sup>(2)</sup>	B - 4 <sup>(3)</sup>		ns
		PHA = 1 <sup>(2)</sup>	A - 4 <sup>(4)</sup>		ns
SM9	t <sub>d(spicklV-csV)</sub> Delay time, SPI_CLK last edge to SPI_CSi inactive	PHA = 0 <sup>(2)</sup>	A - 4 <sup>(4)</sup>		ns
		PHA = 1 <sup>(2)</sup>	B - 4 <sup>(3)</sup>		ns

(1) P = SPI\_CLK period in ns

(2) SPI\_CLK phase is programmable with the PHA bit of the MCSPI\_CHCONF\_0/1/2/3 register

TDA4VH-Q1, TDA4AH-Q1, TDA4VP-Q1, TDA4AP-Q1

JAJSQ14A – FEBRUARY 2023 – REVISED AUGUST 2023

- (3)  $B = (TCS + .5) * TSPICKREF$ , where TCSns a bit field of the MCSPI\_CHCONF\_0/1/2/3 register and Fratio = Even  $\geq 2$ .
- (4) When  $P = 20.8 \text{ ns}$ ,  $A = (TCS + 1) * TSPICKREF$ , where TCSns a bit field of the MCSPI\_CHCONF\_0/1/2/3 register.  
When  $P > 20.8 \text{ ns}$ ,  $A = (TCS + 0.5) * Fratio * TSPICKREF$ , where TCSns a bit field of the MCSPI\_CHCONF\_0/1/2/3 register.

ADVANCE INFORMATION

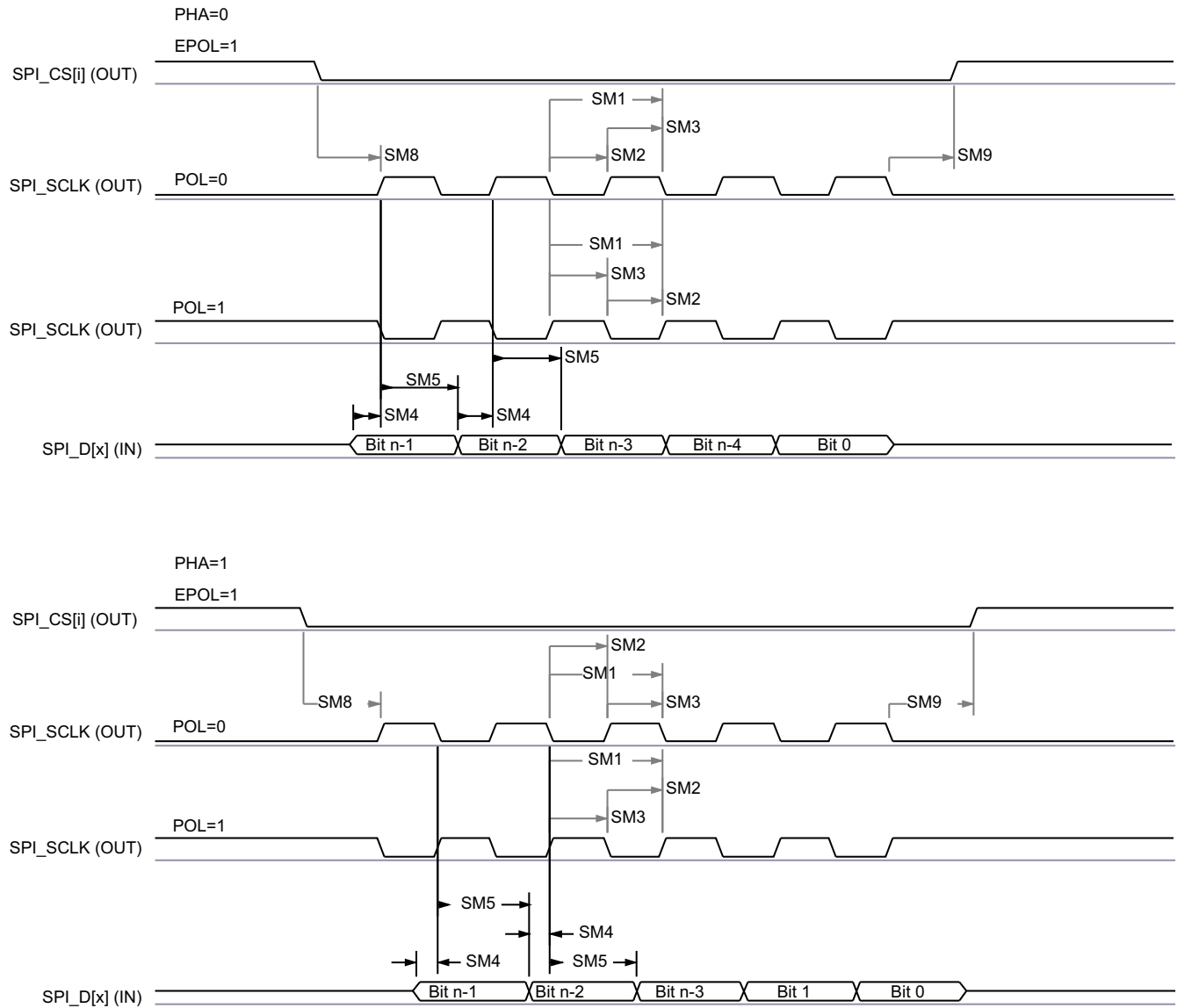

SPRS08\_TIMING\_McSPI\_02

7-73. SPI Controller Mode Receive Timing

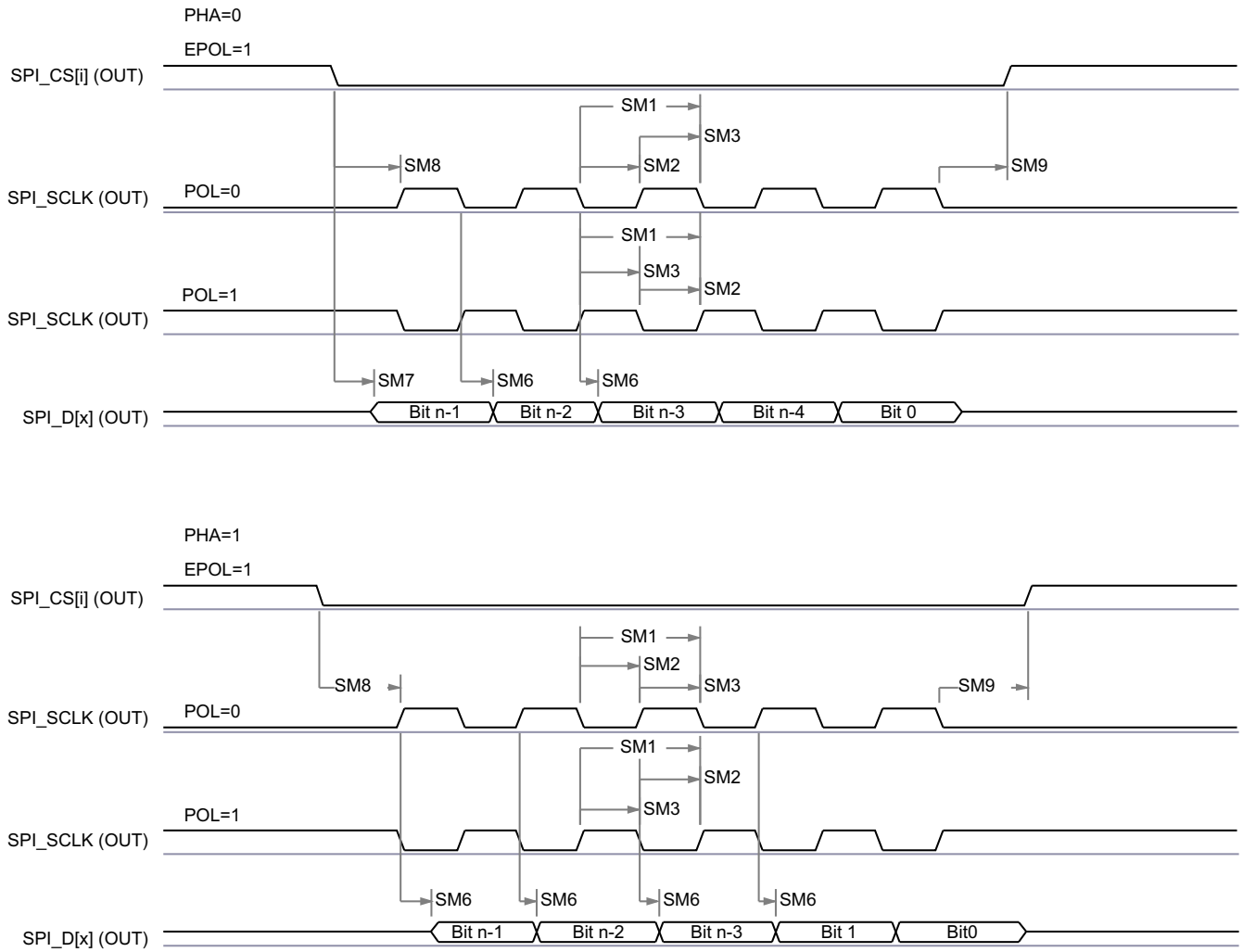

SPRSP08\_TIMING\_McSPI\_01

图 7-74. MCSPI Controller Mode Transmit Timing

### 7.10.5.16.2 MCSPI — Peripheral Mode

表 7-53, 表 7-54, 图 7-75, and 图 7-76 present timing requirements and switching characteristics for MCSPI – Peripheral Mode.

表 7-53. MCSPI Timing Requirements - Peripheral Mode

NO.	PARAMETER	DESCRIPTION	MODE	MIN	MAX	UNIT
SS1	$t_{c(\text{spiclck})}$	Cycle time, SPI_CLK		20.8		ns
SS2	$t_{w(\text{spiclckL})}$	Pulse duration, SPI_CLK low		0.45P <sup>(1)</sup>		ns
SS3	$t_{w(\text{spiclckH})}$	Pulse duration, SPI_CLK high		0.45P <sup>(1)</sup>		ns
SS4	$t_{su(\text{simoV-spiclckV})}$	Setup time, SPI_D[x] valid before SPI_CLK active edge		5		ns
SS5	$t_{h(\text{spiclckV-simoV})}$	Hold time, SPI_D[x] valid after SPI_CLK active edge		5		ns
SS8	$t_{su(\text{csV-spiclckV})}$	Setup time, SPI_CSi valid before SPI_CLK first edge		5		ns
SS9	$t_{h(\text{spiclckV-csV})}$	Hold time, SPI_CSi valid after SPI_CLK last edge		5		ns

**表 7-54. MCSPI Switching Characteristics - Peripheral Mode**

NO.	PARAMETER	DESCRIPTION	MIN	MAX	UNIT
SS6	$t_{d(spickV-somiV)}$	Delay time, SPI_CLK active edge to SPI_D[x] transition	2	17.12	ns
SS7	$t_{sk(csV-somiV)}$	Delay time, SPI_CSi active edge to SPI_D[x] transition	20.95		ns

(1) P = SPI\_CLK period in ns.

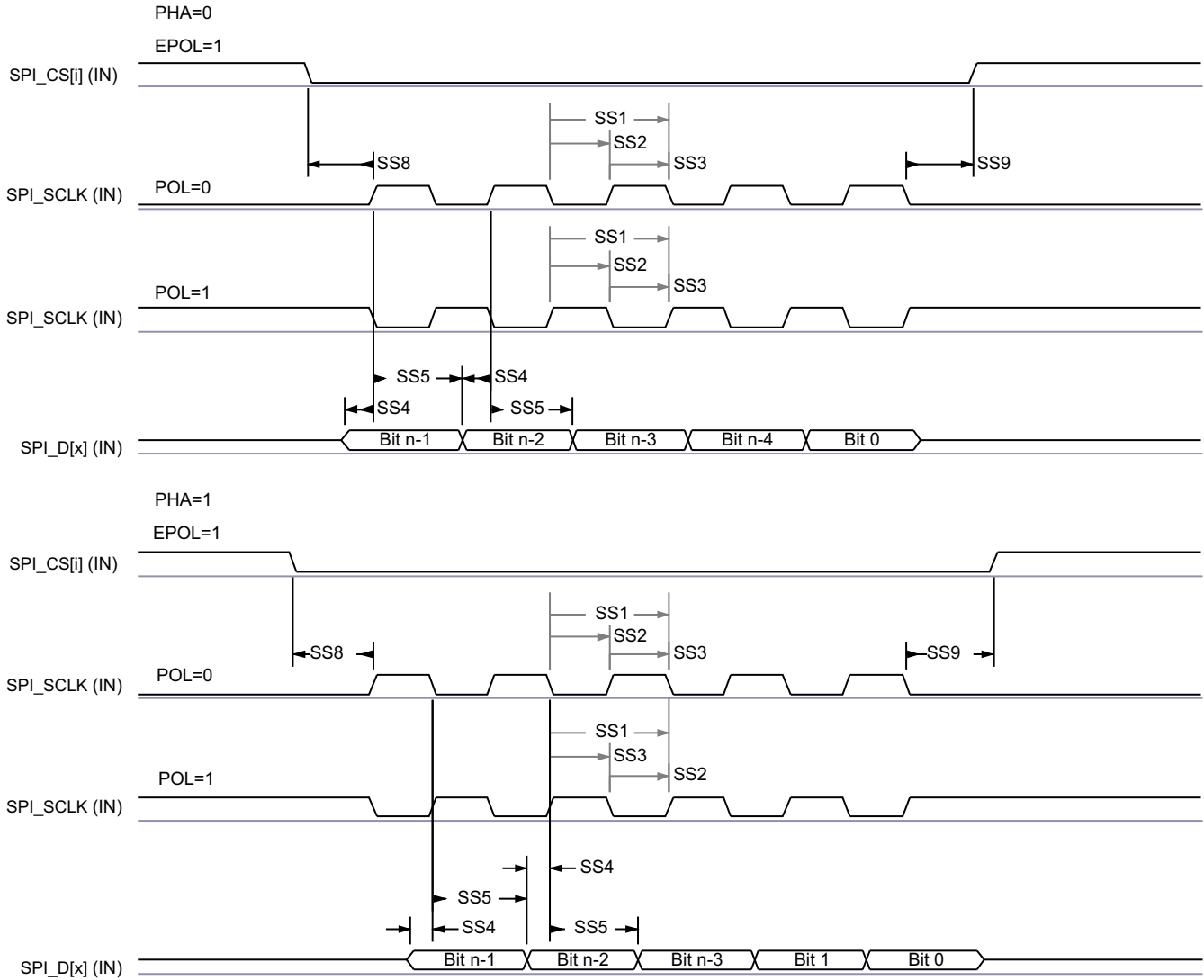

SPRSP08\_TIMING\_McSPI\_04

**图 7-75. SPI Peripheral Mode Receive Timing**

ADVANCE INFORMATION

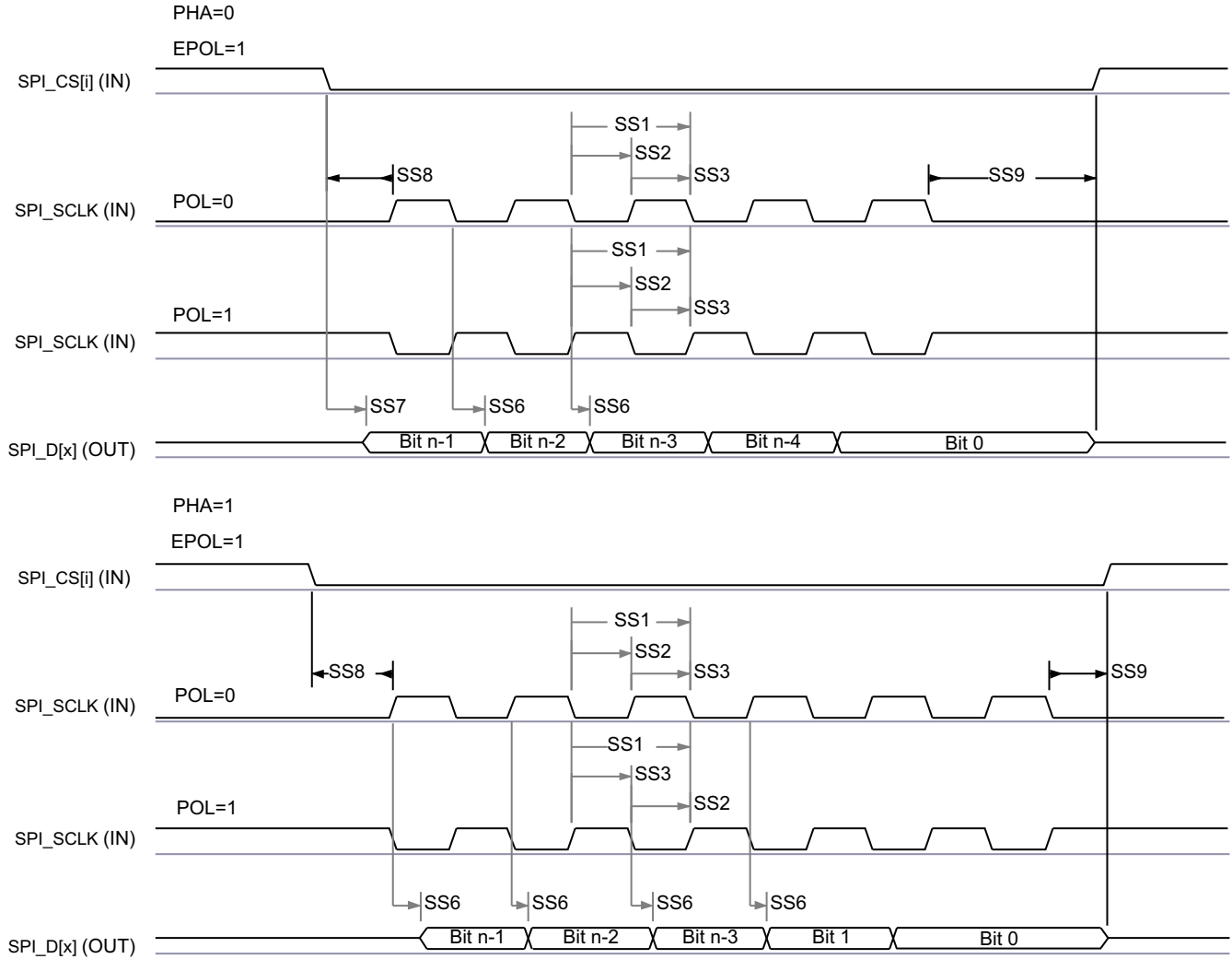

SPRS008\_TIMING\_McSPI\_03

图 7-76. MCSPI Peripheral Mode Transmit Timing

表 7-55 和 表 7-56 呈现了信号分组 (IOSET) 用于 MCU\_SPI0 和 MCU\_SPI1。

表 7-55. MCU\_SPI0 IOSETs

Signals	IOSET1		IOSET2	
	BALL NAME	MUX	BALL NAME	MUX
MCU_SPI0_CLK	MCU_SPI0_CLK	0	MCU_SPI0_CLK	0
MCU_SPI0_D0	MCU_SPI0_D0	0	MCU_SPI0_D0	0
MCU_SPI0_D1	MCU_SPI0_D1	0	MCU_SPI0_D1	0
MCU_SPI0_CS0	MCU_SPI0_CS0	0	MCU_SPI0_CS0	0
MCU_SPI0_CS1	MCU_OSPI1_D3	5	WKUP_GPIO0_12	1
MCU_SPI0_CS2	MCU_OSPI1_CSn1	5	WKUP_GPIO0_14	1

表 7-56. MCU\_SPI1 IOSET

Signals	IOSET1		IOSET2	
	BALL NAME	MUX	BALL NAME	MUX
MCU_SPI1_CLK	MCU_SPI1_CLK	0	MCU_SPI1_CLK	0
MCU_SPI1_D0	MCU_SPI1_D0	0	MCU_SPI1_D0	0
MCU_SPI1_D1	MCU_SPI1_D1	0	MCU_SPI1_D1	0
MCU_SPI1_CS0	MCU_SPI1_CS0	0	MCU_SPI1_CS0	0
MCU_SPI1_CS1	MCU_OSPI1_D1	5	WKUP_GPIO0_13	1
MCU_SPI1_CS2	MCU_OSPI1_D2	5	WKUP_GPIO0_15	1

For more information, see *Multichannel Serial Peripheral Interface (MCSPi)* section in *Peripherals* chapter in the device TRM.

### 7.10.5.17 MMCSD

The MMCSD Host Controller provides an interface to embedded Multi-Media Card (MMC), Secure Digital (SD), and Secure Digital IO (SDIO) devices. The MMCSD Host Controller deals with MMC/SD/SDIO protocol at transmission level, data packing, adding cyclic redundancy checks (CRCs), start/end bit insertion, and checking for syntactical correctness.

For more details about MMCSD interfaces, see the corresponding MMC0, MMC1, and MMC2 sections within [Signal Descriptions](#) and *Detailed Description*.

注

Some operating modes require software configuration of the MMC DLL delay settings, as shown in [表 7-57](#) and [表 7-67](#).

For more information, see *Multi-Media Card/Secure Digital (MMCSD) Interface* section in *Peripherals* chapter in the device TRM.

#### 7.10.5.17.1 MMC0 - eMMC Interface

MMC0 interface is compliant with the JEDEC eMMC electrical standard v5.1 (JESD84-B51) and it supports the following eMMC applications:

- Legacy speed
- High speed SDR
- High speed DDR
- High Speed HS200
- High Speed HS400

[表 7-57](#) presents the required DLL software configuration settings for MMC0 timing modes.

表 7-57. MMC0 DLL Delay Mapping for All Timing Modes

REGISTER NAME		MMCSD0_SS_PHY_CTRL_4_REG					MMCSD0_SS_PHY_CTRL_5_REG		
BIT FIELD		[31:24]	[20]	[15:12]	[8]	[4:0]	[17:16]	[10:8]	[2:0]
BIT FIELD NAME		STRBSEL	OTAPDLYENA	OTAPDLYSEL	ITAPDLYENA	ITAPDLYSEL	SELDLYTXCLK SELDLYRXCLK	FRQSEL	CLKBUFSEL
MODE	DESCRIPTION	STROBE DELAY	OUTPUT DELAY ENABLE	OUTPUT DELAY VALUE	INPUT DELAY ENABLE	INPUT DELAY VALUE	DLL/ DELAY CHAIN SELECT	DLL REF FREQUENCY	DELAY BUFFER DURATION
Legacy SDR	8-bit PHY operating 1.8 V, 25 MHz	0x0	0x0	NA	0x1	0x10	0x1	0x0	0x7
High Speed SDR	8-bit PHY operating 1.8 V, 50 MHz	0x0	0x0	NA	0x1	0xA	0x1	0x0	0x7



表 7-57. MMC0 DLL Delay Mapping for All Timing Modes (continued)

REGISTER NAME		MMCS0_SS_PHY_CTRL_4_REG					MMCS0_SS_PHY_CTRL_5_REG		
BIT FIELD		[31:24]	[20]	[15:12]	[8]	[4:0]	[17:16]	[10:8]	[2:0]
BIT FIELD NAME		STRBSEL	OTAPDLYENA	OTAPDLYSEL	ITAPDLYENA	ITAPDLYSEL	SELDLYTXCLK SELDLYRXCLK	FRQSEL	CLKBUFSEL
MODE	DESCRIPTION	STROBE DELAY	OUTPUT DELAY ENABLE	OUTPUT DELAY VALUE	INPUT DELAY ENABLE	INPUT DELAY VALUE	DLL/ DELAY CHAIN SELECT	DLL REF FREQUENCY	DELAY BUFFER DURATION
High Speed DDR	8-bit PHY operating 1.8 V, 50 MHz	0x0	0x1	0x6	0x1	Tuning	0x0	0x4	0x7
HS200	8-bit PHY operating 1.8 V, 200 MHz	0x0	0x1	0x8	0x1	Tuning	0x0	0x0	0x7
HS400	8-bit PHY operating 1.8 V, 200 MHz	0x66	0x1	0x5	0x1	Tuning	0x0	0x0	0x7

表 7-58 presents timing conditions for MMC0.

表 7-58. MMC0 Timing Conditions

PARAMETER		MIN	MAX	UNIT	
<b>INPUT CONDITIONS</b>					
SR <sub>i</sub>	Input slew rate	Legacy SDR	0.14	1.44	V/ns
		High Speed SDR	0.3	0.90	V/ns
		High Speed DDR (CMD)	0.3	0.90	V/ns
		High Speed DDR (DAT[7:0])	0.45	0.90	V/ns
<b>OUTPUT CONDITIONS</b>					
C <sub>L</sub>	Output load capacitance	HS200, HS400	1	6	pF
		All other modes	1	12	pF
<b>PCB CONNECTIVITY REQUIREMENTS</b>					
t <sub>d</sub> (Trace Delay)	Propagation delay of each trace	All modes	134	756	ps
t <sub>d</sub> (Trace Mismatch Delay)	Propagation delay mismatch across all traces	Legacy SDR, High Speed SDR, High Speed DDR		100	ps
		HS200, HS400		8	ps

7.10.5.17.1.1 Legacy SDR Mode

表 7-59, 图 7-77, 表 7-60, and 图 7-78 present timing requirements and switching characteristics for MMC0 – Legacy SDR Mode.

表 7-59. MMC0 Timing Requirements – Legacy SDR Mode

see 图 7-77

NO.			MIN	MAX	UNIT
LSDR1	$t_{su}(cmdV-clkH)$	Setup time, MMC0_CMD valid before MMC0_CLK rising edge	2.5		ns
LSDR2	$t_h(clkH-cmdV)$	Hold time, MMC0_CMD valid after MMC0_CLK rising edge	6.5		ns
LSDR3	$t_{su}(dV-clkH)$	Setup time, MMC0_DAT[7:0] valid before MMC0_CLK rising edge	2.5		ns
LSDR4	$t_h(clkH-dV)$	Hold time, MMC0_DAT[7:0] valid after MMC0_CLK rising edge	6.5		ns



图 7-77. MMC0 – Legacy SDR – Receive Mode

表 7-60. MMC0 Switching Characteristics – Legacy SDR Mode

see 图 7-78

NO.	PARAMETER		MIN	MAX	UNIT
	$f_{op}(clk)$	Operating frequency, MMC0_CLK		25	MHz
LSDR5	$t_c(clk)$	Cycle time, MMC0_CLK	40		ns
LSDR6	$t_w(clkH)$	Pulse duration, MMC0_CLK high	18.7		ns
LSDR7	$t_w(clkL)$	Pulse duration, MMC0_CLK low	18.7		ns
LSDR8	$t_d(clkL-cmdV)$	Delay time, MMC0_CLK falling edge to MMC0_CMD transition	-3.2	3.8	ns
LSDR9	$t_d(clkL-dV)$	Delay time, MMC0_CLK falling edge to MMC0_DAT[7:0] transition	-3.2	3.8	ns

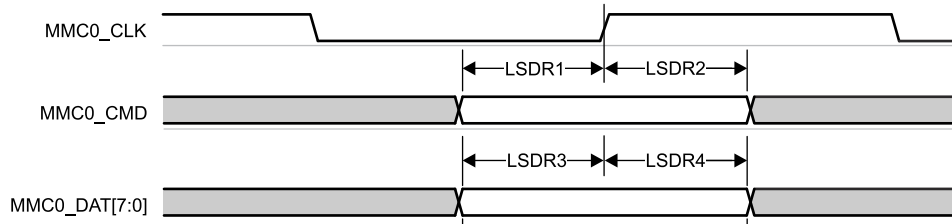

图 7-78. MMC0 – Legacy SDR – Transmit Mode

### 7.10.5.17.1.2 High Speed SDR Mode

表 7-61, 図 7-79, 表 7-62, and 図 7-80 present timing requirements and switching characteristics for MMC0 – High Speed SDR Mode.

表 7-61. MMC0 Timing Requirements – High Speed SDR Mode

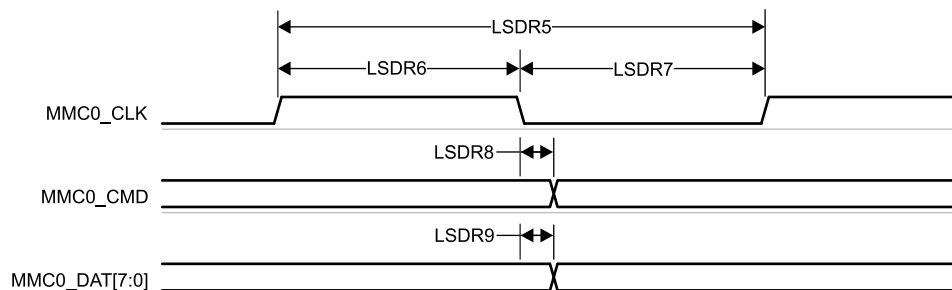
see 図 7-79

NO.			MIN	MAX	UNIT
HSSDR1	$t_{su(cmdV-clkH)}$	Setup time, MMC0_CMD valid before MMC0_CLK rising edge	2.99		ns
HSSDR2	$t_{h(clkH-cmdV)}$	Hold time, MMC0_CMD valid after MMC0_CLK rising edge	2.67		ns
HSSDR3	$t_{su(dV-clkH)}$	Setup time, MMC0_DAT[7:0] valid before MMC0_CLK rising edge	2.99		ns
HSSDR4	$t_{h(clkH-dV)}$	Hold time, MMC0_DAT[7:0] valid after MMC0_CLK rising edge	2.67		ns



図 7-79. MMC0 – High Speed SDR Mode – Receive Mode

表 7-62. MMC0 Switching Characteristics – High Speed SDR Mode

see 図 7-80

NO.	PARAMETER		MIN	MAX	UNIT
	$f_{op(clk)}$	Operating frequency, MMC0_CLK		50	MHz
HSSDR5	$t_{c(clk)}$	Cycle time, MMC0_CLK	20		ns
HSSDR6	$t_{w(clkH)}$	Pulse duration, MMC0_CLK high	9.2		ns
HSSDR7	$t_{w(clkL)}$	Pulse duration, MMC0_CLK low	9.2		ns
HSSDR8	$t_{d(clkL-cmdV)}$	Delay time, MMC0_CLK falling edge to MMC0_CMD transition	-3.2	3.8	ns
HSSDR9	$t_{d(clkL-dV)}$	Delay time, MMC0_CLK falling edge to MMC0_DAT[7:0] transition	-3.2	3.8	ns

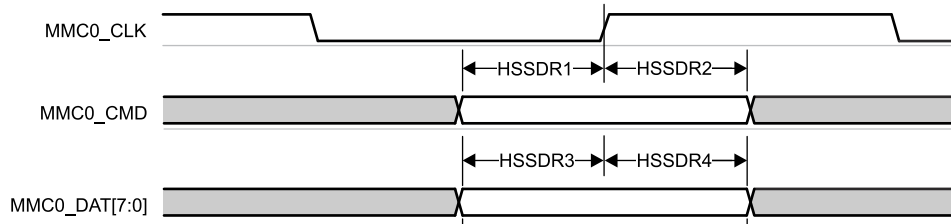

図 7-80. MMC0 – High Speed SDR Mode – Transmit Mode

7.10.5.17.1.3 High Speed DDR Mode

表 7-63, 图 7-81, 表 7-64, and 图 7-82 present timing requirements and switching characteristics for MMC0 – High Speed DDR Mode.

表 7-63. MMC0 Timing Requirements – High Speed DDR Mode

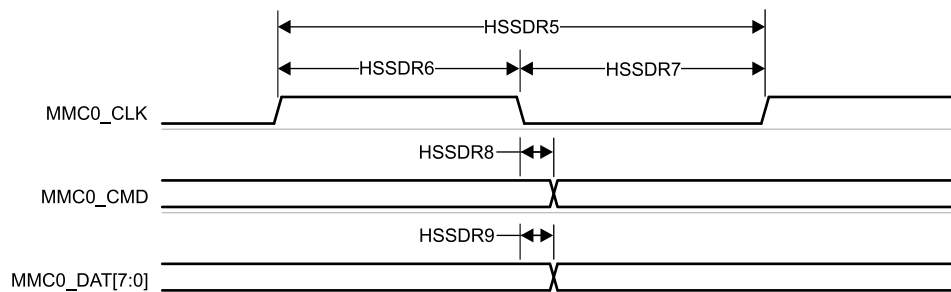
see 图 7-81

NO.			MIN	MAX	UNIT
HSDDR1	$t_{su(cmdV-clkH)}$	Setup time, MMC0_CMD valid before MMC0_CLK rising edge	3.79		ns
HSDDR2	$t_{h(clkH-cmdV)}$	Hold time, MMC0_CMD valid after MMC0_CLK rising edge	2.67		ns
HSDDR3	$t_{su(dV-clkV)}$	Setup time, MMC0_DAT[7:0] valid before MMC0_CLK transition	0.74		ns
HSDDR4	$t_{h(clkV-dV)}$	Hold time, MMC0_DAT[7:0] valid after MMC0_CLK transition	1.67		ns



图 7-81. MMC0 – High Speed DDR Mode – Receive Mode

表 7-64. MMC0 Switching Characteristics – High Speed DDR Mode

see 图 7-82

NO.	PARAMETER	MIN	MAX	UNIT
	$f_{op(clk)}$		50	MHz
HSDDR5	$t_{c(clk)}$	20		ns
HSDDR6	$t_{w(clkH)}$	9.2		ns
HSDDR7	$t_{w(clkL)}$	9.2		ns
HSDDR8	$t_{d(clkH-cmdV)}$	3.4	9.8	ns
HSDDR9	$t_{d(clkV-dV)}$	2.9	6.85	ns

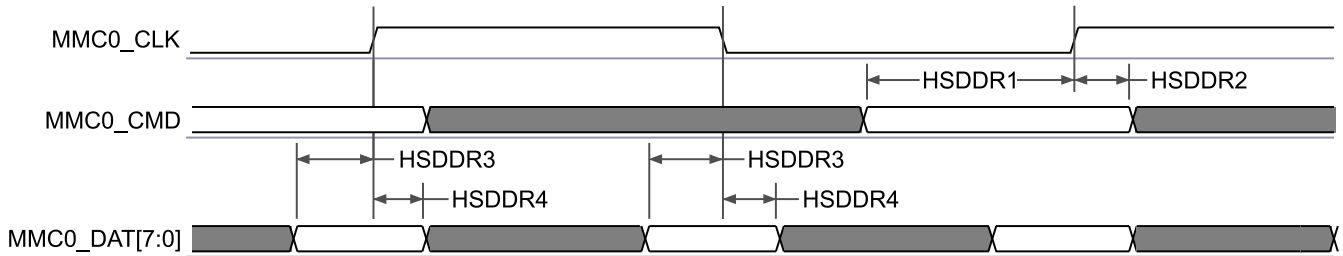

图 7-82. MMC0 – High Speed DDR Mode – Transmit Mode

7.10.5.17.1.4 HS200 Mode

表 7-65 and 図 7-83 present switching characteristics for MMC0 – HS200 Mode.

表 7-65. MMC0 Switching Characteristics – HS200 Mode

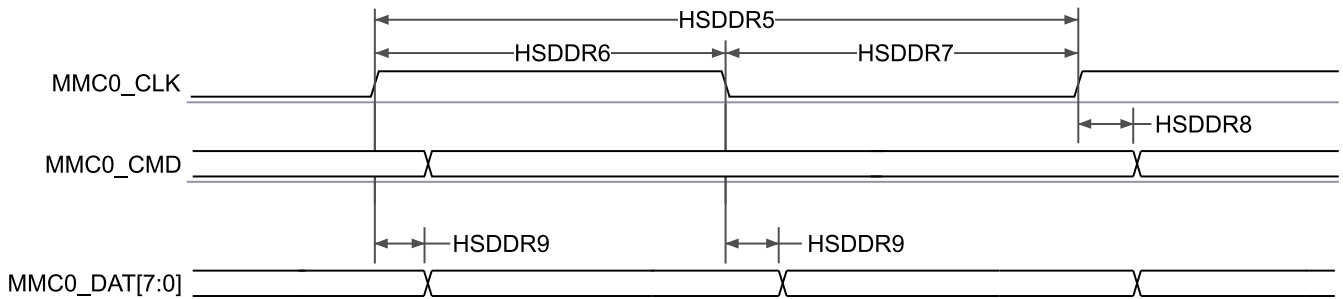
see 図 7-83

NO.	PARAMETER		MIN	MAX	UNIT
	$f_{op}(clk)$	Operating frequency, MMC0_CLK		200	MHz
HS2005	$t_{c}(clk)$	Cycle time, MMC0_CLK	5		ns
HS2006	$t_{w}(clkH)$	Pulse duration, MMC0_CLK high	2.08		ns
HS2007	$t_{w}(clkL)$	Pulse duration, MMC0_CLK low	2.08		ns
HS2008	$t_{d}(clkL-cmdV)$	Delay time, MMC0_CLK rising edge to MMC0_CMD transition	0.99	3.16	ns
HS2009	$t_{d}(clkL-dV)$	Delay time, MMC0_CLK rising edge to MMC0_DAT[7:0] transition	0.99	3.16	ns



図 7-83. MMC0 – HS200 Mode – Transmit Mode

7.10.5.17.1.5 HS400 Mode

表 7-66 and 図 7-84 present switching characteristics for MMC0 – HS400 Mode.

表 7-66. MMC0 Switching Characteristics – HS400 Mode

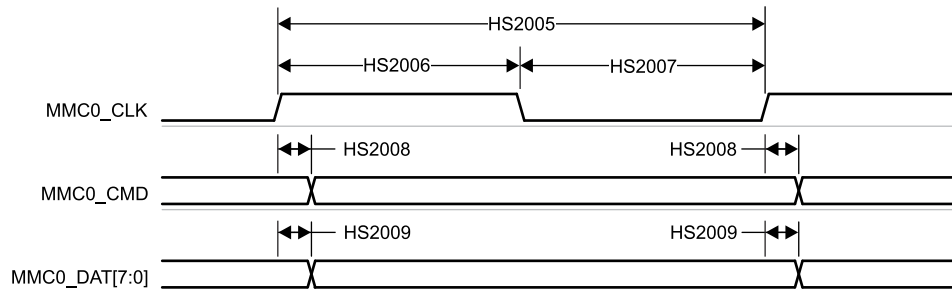
see 図 7-84

NO.	PARAMETER	DESCRIPTION	MIN	MAX	UNIT
	$f_{op}(clk)$	Operating frequency, MMC0_CLK		200	MHz
HS4005	$t_{c}(clk)$	Cycle time, MMC0_CLK	5		ns
HS4006	$t_{w}(clkH)$	Pulse duration, MMC0_CLK high	2.08		ns
HS4007	$t_{w}(clkL)$	Pulse duration, MMC0_CLK low	2.08		ns
HS4008	$t_{d}(clkH-cmdV)$	Delay time, MMC0_CLK rising clock edge to MMC0_CMD transition	0.99	3.28	ns
HS4009	$t_{d}(clkV-dV)$	Delay time, MMC0_CLK transition to MMC0_DAT[7:0] transition	0.59	1.84	ns



図 7-84. eMMC in – HS400 Mode – Transmitter Mode

### 7.10.5.17.2 MMC1/2 - SD/SDIO Interface

MMC1 interface is compliant with the SD Host Controller Standard Specification 4.10 and SD Physical Layer Specification v3.01 as well as SDIO Specification v3.00 and they support the following SD Card applications:

- Default speed
- High speed
- UHS-I SDR12
- UHS-I SDR25
- UHS-I SDR50
- UHS-I SDR104
- UHS-I DDR50

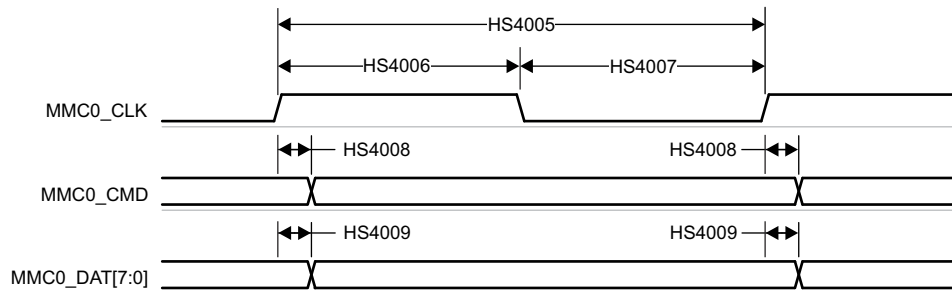
表 7-67 presents the required DLL software configuration settings for MMC1 timing modes.

**表 7-67. MMC1 DLL Delay Mapping for All Timing Modes**

REGISTER NAME		MMCS12_SS_PHY_CTRL_4_REG				MMCS12_SS_PHY_CTRL_5_REG
BIT FIELD		[20]	[15:12]	[8]	[4:0]	[2:0]
BIT FIELD NAME		OTAPDLYENA	OTAPDLYSEL	ITAPDLYENA	ITAPDLYSEL	CLKBUFSEL
MODE	DESCRIPTION	DELAY ENABLE	DELAY VALUE	INPUT DELAY ENABLE	INPUT DELAY VALUE	DELAY BUFFER DURATION
Default Speed	4-bit PHY operating 3.3 V, 25 MHz	0x0	0x0	0x0	0x0	0x7
High Speed	4-bit PHY operating 3.3 V, 50 MHz	0x0	0x0	0x0	0x0	0x7
UHS-I SDR12	4-bit PHY operating 1.8 V, 25 MHz	0x1	0xF	0x0	0x0	0x7
UHS-I SDR25	4-bit PHY operating 1.8 V, 50 MHz	0x1	0xF	0x0	0x0	0x7
UHS-I SDR50	4-bit PHY operating 1.8 V, 100 MHz	0x1	0xC	0x1	Tuning	0x7
UHS-I DR50	4-bit PHY operating 1.8 V, 50 MHz	0x1	0xC	0x1	0x2	0x7
UHS-I SDR104	4-bit PHY operating 1.8 V, 200 MHz	0x1	0x5	0x1	Tuning	0x7

表 7-68 presents timing conditions for MMC1.

**表 7-68. MMC1 Timing Conditions**

PARAMETER		MIN	MAX	UNIT	
<b>INPUT CONDITIONS</b>					
SR <sub>i</sub>	Input slew rate	Default Speed, High Speed	0.69	2.06	V/ns
		UHS-I SDR12, UHS-I SDR25	0.34	1.34	V/ns
		UHS-I DDR50	1.00	2.00	V/ns
<b>OUTPUT CONDITIONS</b>					
C <sub>L</sub>	Output load capacitance	All modes	1	10	pF
<b>PCB CONNECTIVITY REQUIREMENTS</b>					
t <sub>d</sub> (Trace Delay)	Propagation delay of each trace	UHS-I DDR50	240.03	1134	ps
		All other modes	126	1386	ps
t <sub>d</sub> (Trace Mismatch Delay)	Propagation delay mismatch across all traces	UHS-I DDR50		20	ps
		UHS-I SDR104		8	ps
		All other modes		100	ps

7.10.5.17.2.1 Default Speed Mode

表 7-69, 图 7-85, 表 7-70, and 图 7-86 present timing requirements and switching characteristics for MMC1/2 – Default Speed Mode.

表 7-69. MMC1/2 Timing Requirements – Default Speed Mode

see 图 7-85

NO.			MIN	MAX	UNIT
DS1	$t_{su}(cmdV-clkH)$	Setup time, MMC[x]_CMD valid before MMC[x]_CLK rising edge	2.15		ns
DS2	$t_h(clkH-cmdV)$	Hold time, MMC[x]_CMD valid after MMC[x]_CLK rising edge	4.56		ns
DS3	$t_{su}(dV-clkH)$	Setup time, MMC[x]_DAT[3:0] valid before MMC[x]_CLK rising edge	2.15		ns
DS4	$t_h(clkH-dV)$	Hold time, MMC[x]_DAT[3:0] valid after MMC[x]_CLK rising edge	4.56		ns

- A. x = 1, 2 for MMC1 and MMC2
- B. x = 1, 2 for MMC1 and MMC2



图 7-85. MMC1/2 – Default Speed – Receive Mode

表 7-70. MMC1/2 Switching Characteristics – Default Speed Mode

see 图 7-86

NO.	PARAMETER	MIN	MAX	UNIT
	$f_{op}(clk)$		25	MHz
DS5	$t_c(clk)$	40		ns
DS6	$t_w(clkH)$	18.7		ns
DS7	$t_w(clkL)$	18.7		ns
DS8	$t_d(clkL-cmdV)$	-3.53	3.53	ns
DS9	$t_d(clkL-dV)$	-3.53	3.53	ns

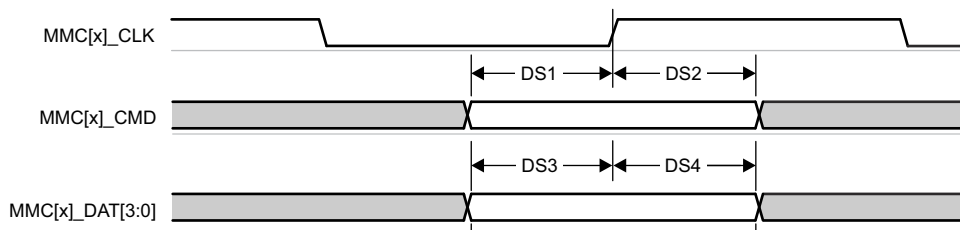

图 7-86. MMC1/2 – Default Speed – Transmit Mode

7.10.5.17.2.2 High Speed Mode

表 7-71, 图 7-87, 表 7-72, and 图 7-88 present timing requirements and switching characteristics for MMC1/2 – High Speed Mode.

表 7-71. MMC1/2 Timing Requirements – High Speed Mode

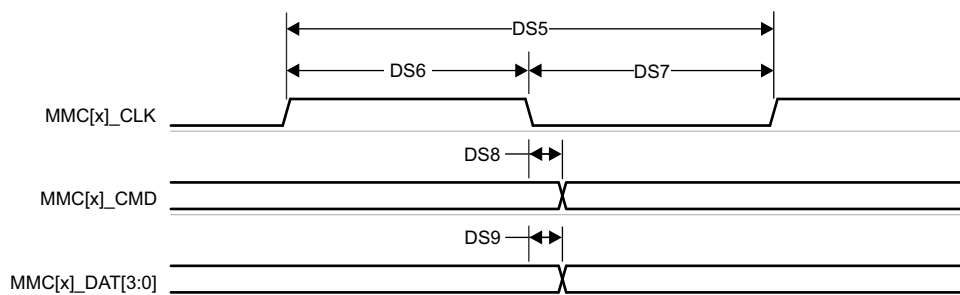
see 图 7-87

NO.			MIN	MAX	UNIT
HS1	$t_{su}(cmdV-clkH)$	Setup time, MMC[x]_CMD valid before MMC[x]_CLK rising edge	2.15		ns
HS2	$t_h(clkH-cmdV)$	Hold time, MMC[x]_CMD valid after MMC[x]_CLK rising edge	2.26		ns
HS3	$t_{su}(dV-clkH)$	Setup time, MMC[x]_DAT[3:0] valid before MMC[x]_CLK rising edge	2.15		ns
HS4	$t_h(clkH-dV)$	Hold time, MMC[x]_DAT[3:0] valid after MMC[x]_CLK rising edge	2.26		ns

- A. x = 1, 2 for MMC1 and MMC2
- B. x = 1, 2 for MMC1 and MMC2



图 7-87. MMC1 /2– High Speed – Receive Mode

表 7-72. MMC1/2 Switching Characteristics – High Speed Mode

see 图 7-88

NO.	PARAMETER	MIN	MAX	UNIT
	$f_{op}(clk)$		50	MHz
HS5	$t_c(clk)$	20		ns
HS6	$t_w(clkH)$	9.2		ns
HS7	$t_w(clkL)$	9.2		ns
HS8	$t_d(clkL-cmdV)$	-2.07	2.07	ns
HS9	$t_d(clkL-dV)$	-2.07	2.07	ns

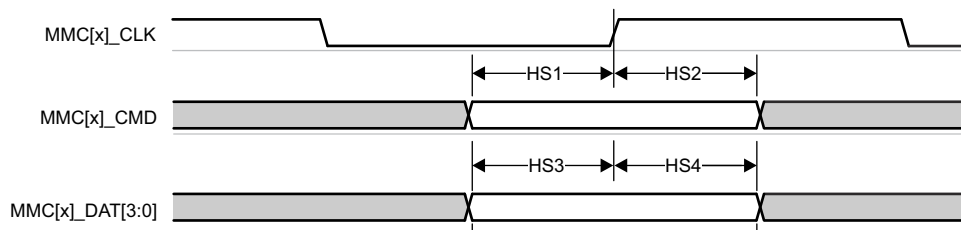

图 7-88. MMC1/2 – High Speed – Transmit Mode

ADVANCE INFORMATION

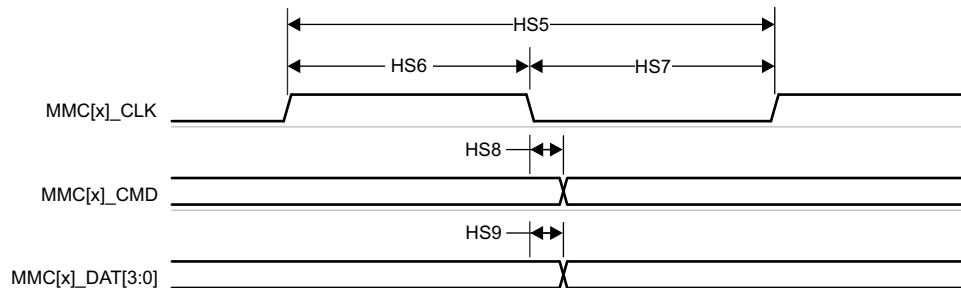

7.10.5.17.2.3 UHS-I SDR12 Mode

表 7-73, 图 7-89, 表 7-74, and 图 7-90 present timing requirements and switching characteristics for MMC1/2 – UHS-I SDR12 Mode.

表 7-73. MMC1/2 Timing Requirements – UHS-I SDR12 Mode

see 图 7-89

NO.			MIN	MAX	UNIT
SDR121	$t_{su(cmdV-clkH)}$	Setup time, MMC[x]_CMD valid before MMC[x]_CLK rising edge	5.46		ns
SDR122	$t_{h(clkH-cmdV)}$	Hold time, MMC[x]_CMD valid after MMC[x]_CLK rising edge	1.67		ns
SDR123	$t_{su(dV-clkH)}$	Setup time, MMC[x]_DAT[3:0] valid before MMC[x]_CLK rising edge	5.46		ns
SDR124	$t_{h(clkH-dV)}$	Hold time, MMC[x]_DAT[3:0] valid after MMC[x]_CLK rising edge	1.67		ns

- A. x = 1, 2 for MMC1 and MMC2
- B. x = 1, 2 for MMC1 and MMC2



图 7-89. MMC1/2 – UHS-I SDR12 – Receive Mode

表 7-74. MMC1/2 Switching Characteristics – UHS-I SDR12 Mode

see 图 7-90

NO.	PARAMETER	MIN	MAX	UNIT
	$f_{op(clk)}$		25	MHz
SDR125	$t_{c(clk)}$	40		ns
SDR126	$t_{w(clkH)}$	18.7		ns
SDR127	$t_{w(clkL)}$	18.7		ns
SDR128	$t_{d(clkH-cmdV)}$	1.2	13.55	ns
SDR129	$t_{d(clkH-dV)}$	1.2	13.55	ns

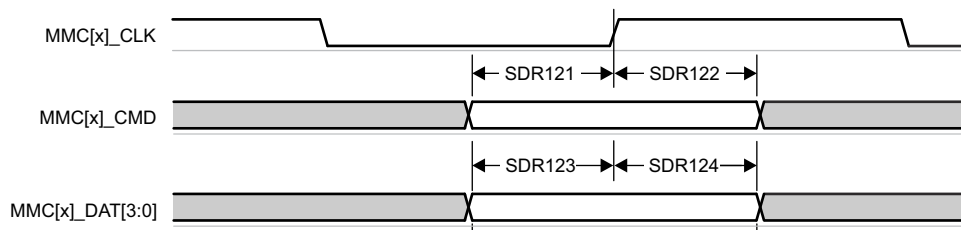

图 7-90. MMC1/2 – UHS-I SDR12 – Transmit Mode

7.10.5.17.2.4 UHS-I SDR25 Mode

表 7-75, 图 7-91, 表 7-76, and 图 7-92 present timing requirements and switching characteristics for MMC1/2 – UHS-I SDR25 Mode.

表 7-75. MMC1/2 Timing Requirements – UHS-I SDR25 Mode

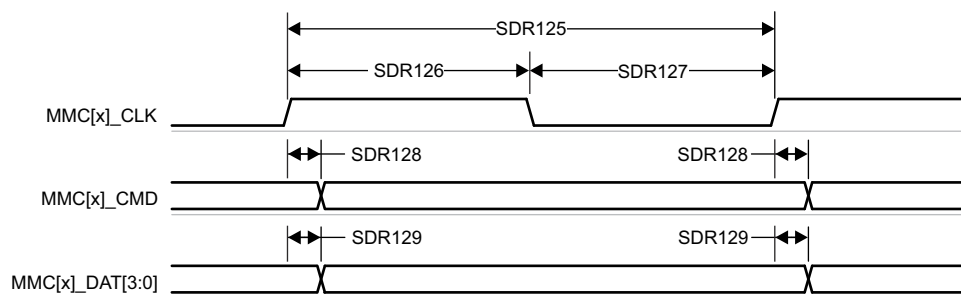
see 图 7-91

NO.			MIN	MAX	UNIT
SDR251	$t_{su(cmdV-clkH)}$	Setup time, MMC[x]_CMD valid before MMC[x]_CLK rising edge	2.1		ns
SDR252	$t_{h(clkH-cmdV)}$	Hold time, MMC[x]_CMD valid after MMC[x]_CLK rising edge	1.67		ns
SDR253	$t_{su(dV-clkH)}$	Setup time, MMC[x]_DAT[3:0] valid before MMC[x]_CLK rising edge	2.1		ns
SDR254	$t_{h(clkH-dV)}$	Hold time, MMC[x]_DAT[3:0] valid after MMC[x]_CLK rising edge	1.67		ns

- A. x = 1, 2 for MMC1 and MMC2
- B. x = 1, 2 for MMC1 and MMC2



图 7-91. MMC1/2 – UHS-I SDR25 – Receive Mode

表 7-76. MMC1/2 Switching Characteristics – UHS-I SDR25 Mode

see 图 7-92

NO.	PARAMETER	MIN	MAX	UNIT
	$f_{op(clk)}$		50	MHz
SDR255	$t_{c(clk)}$	20		ns
SDR256	$t_{w(clkH)}$	9.2		ns
SDR257	$t_{w(clkL)}$	9.2		ns
SDR258	$t_{d(clkH-cmdV)}$	2.4	9.37	ns
SDR259	$t_{d(clkH-dV)}$	2.4	9.37	ns

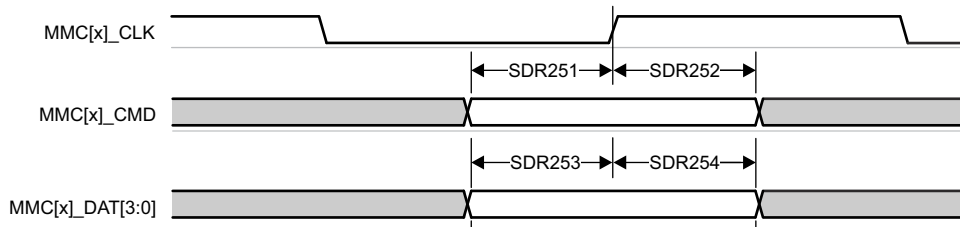

图 7-92. MMC1/2 – UHS-I SDR25 – Transmit Mode

7.10.5.17.2.5 UHS-I SDR50 Mode

表 7-77, and 図 7-93 presents switching characteristics for MMC1/2 – UHS-I SDR50 Mode.

表 7-77. MMC1/2 Switching Characteristics – UHS-I SDR50 Mode

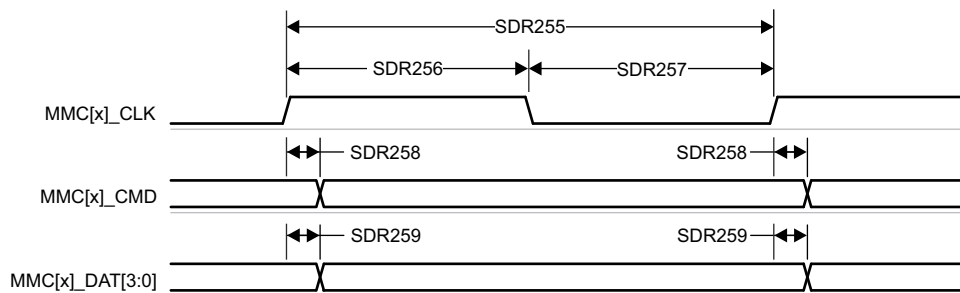
see 図 7-93

NO.	PARAMETER		MIN	MAX	UNIT
	$f_{op}(clk)$	Operating frequency, MMC[x]_CLK		100	MHz
SDR505	$t_{c}(clk)$	Cycle time, MMC[x]_CLK	10		ns
SDR506	$t_{w}(clkH)$	Pulse duration, MMC[x]_CLK high	4.45		ns
SDR507	$t_{w}(clkL)$	Pulse duration, MMC[x]_CLK low	4.45		ns
SDR508	$t_{d}(clkH-cmdV)$	Delay time, MMC[x]_CLK rising edge to MMC[x]_CMD transition	1.2	6.35	ns
SDR509	$t_{d}(clkH-dV)$	Delay time, MMC[x]_CLK rising edge to MMC[x]_DAT[3:0] transition	1.2	6.35	ns

A. x = 1, 2 for MMC1 and MMC2



図 7-93. MMC1/2 – UHS-I SDR50 – Transmit Mode

7.10.5.17.2.6 UHS-I DDR50 Mode

表 7-78 and 图 7-94 present switching characteristics for MMC1/2 – UHS-I DDR50 Mode.

表 7-78. MMC1/2 Switching Characteristics – UHS-I DDR50 Mode

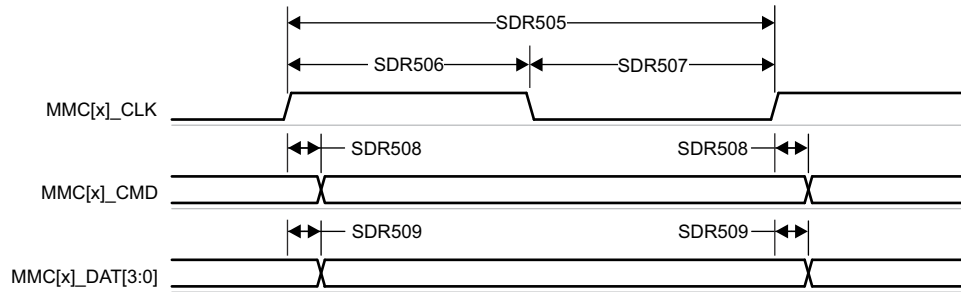
see 图 7-94

NO.	PARAMETER	MIN	MAX	UNIT
	$f_{op}(clk)$		40	MHz
DDR505	$t_{c}(clk)$	25		ns
DDR506	$t_{w}(clkH)$	9.2		ns
DDR507	$t_{w}(clkL)$	9.2		ns
DDR508	$t_{d}(clkH-cmdV)$	1.12	3.46	ns
DDR509	$t_{d}(clk-dV)$	1.12	6.12	ns

A. x = 1, 2 for MMC1 and MMC2



图 7-94. MMC1/2 – UHS-I DDR50 – Transmit Mode

### 7.10.5.17.2.7 UHS-I SDR104 Mode

表 7-79, and 図 7-95 present switching characteristics for MMC1/2 – UHS-I SDR104 Mode.

表 7-79. MMC1/2 Switching Characteristics – UHS-I SDR104 Mode

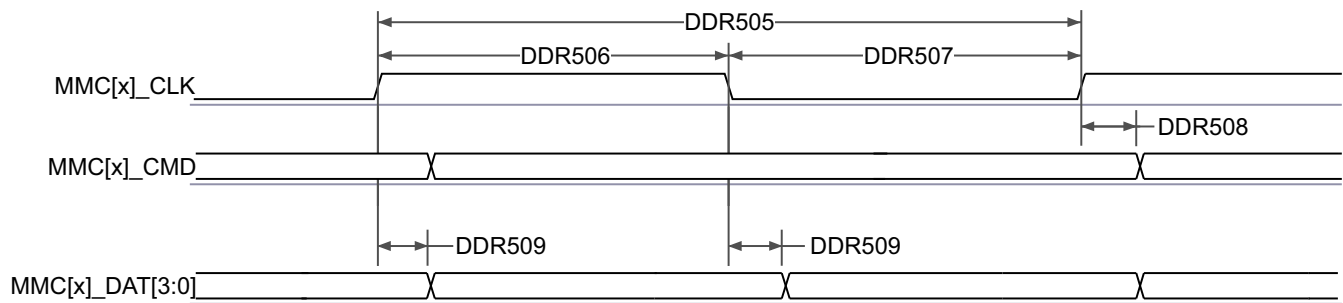
see 図 7-95

NO.	PARAMETER		MIN	MAX	UNIT
	$f_{op}(clk)$	Operating frequency, MMC[x]_CLK		200	MHz
SDR1045	$t_{c}(clk)$	Cycle time, MMC[x]_CLK	5		ns
SDR1046	$t_{w}(clkH)$	Pulse duration, MMC[x]_CLK high	2.12		ns
SDR1047	$t_{w}(clkL)$	Pulse duration, MMC[x]_CLK low	2.12		ns
SDR1048	$t_{d}(clkH-cmdV)$	Delay time, MMC[x]_CLK rising edge to MMC[x]_CMD transition	1.07	3.21	ns
SDR1049	$t_{d}(clkH-dV)$	Delay time, MMC[x]_CLK rising edge to MMC[x]_DAT[3:0] transition	1.07	3.21	ns

A. x = 1, 2 for MMC1 and MMC2



図 7-95. MMC1/2 – UHS-I SDR104 – Transmit Mode

### 7.10.5.18 CPTS

表 7-80 represents CPTS timing conditions.

表 7-80. CPTS Timing Conditions

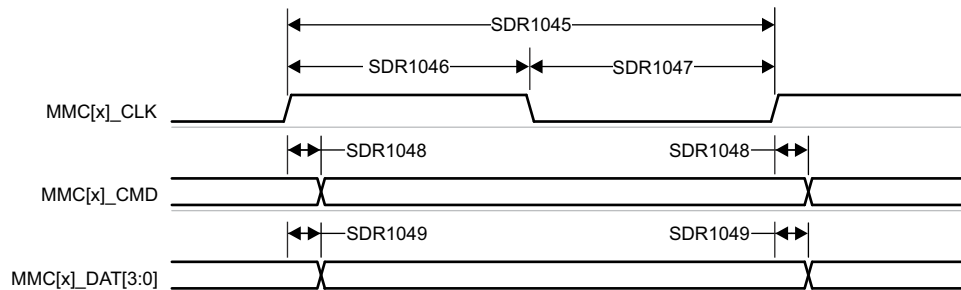
PARAMETER	DESCRIPTION	MIN	MAX	UNIT
<b>INPUT CONDITIONS</b>				
$SR_i$	Input slew rate	0.5	5	V/ns
<b>OUTPUT CONDITIONS</b>				
$C_L$	Output load capacitance	2	10	pF

セクション 7.10.5.18.1, セクション 7.10.5.18.2, 図 7-96, and 図 7-97 present timing requirements and switching characteristics of the CPTS interface.

#### 7.10.5.18.1 CPTS Timing Requirements

see 図 7-96

NO.	PARAMETER		MIN	MAX	UNIT
T1	$t_{w}(HWnTSPUSH)$	Pulse duration, HWnTSPUSH <sup>(2)</sup> high	$12P + 2^{(1)}$		ns
T2	$t_{w}(HWnTSPUSHL)$	Pulse duration, HWnTSPUSH <sup>(2)</sup> low	$12P + 2^{(1)}$		ns
T3	$t_{c}(RFT\_CLK)$	Cycle time, RFT_CLK	5	8	ns
T4	$t_{w}(RFT\_CLKH)$	Pulse duration, RFT_CLK high	$0.45 * T^{(3)}$		ns
T5	$t_{w}(RFT\_CLKL)$	Pulse duration, RFT_CLK low	$0.45 * T^{(3)}$		ns

(1) P = functional clock period in ns.

(2) In HWnTSPUSH, n = 1 to 2.

(3) T = RFT\_CLK period in ns.



图 7-96. CPTS Timing Requirements

7.10.5.18.2 CPTS Switching Characteristics

see 图 7-97

NO.	PARAMETER	SOURCE	MIN	MAX	UNIT
T6	$t_w(TS\_COMPH)$	Pulse duration, TS_COMP high	36P - 2 <sup>(1)</sup>		ns
T7	$t_w(TS\_COMPL)$	Pulse duration, TS_COMP low	36P - 2 <sup>(1)</sup>		ns
T8	$t_w(TS\_SYNCH)$	Pulse duration, TS_SYNC high	36P - 2 <sup>(1)</sup>		ns
T9	$t_w(TS\_SYNCL)$	Pulse duration, TS_SYNC low	36P - 2 <sup>(1)</sup>		ns
T10	$t_w(SYNcN\_OUTH)$	TS_SYNC	36P - 2 <sup>(1)</sup>		ns
		TS_GENF	5P - 2 <sup>(1)</sup>		ns
T11	$t_w(SYNcN\_OUTL)$	TS_SYNC	36P - 2 <sup>(1)</sup>		ns
		TS_GENF	5P - 2 <sup>(1)</sup>		ns

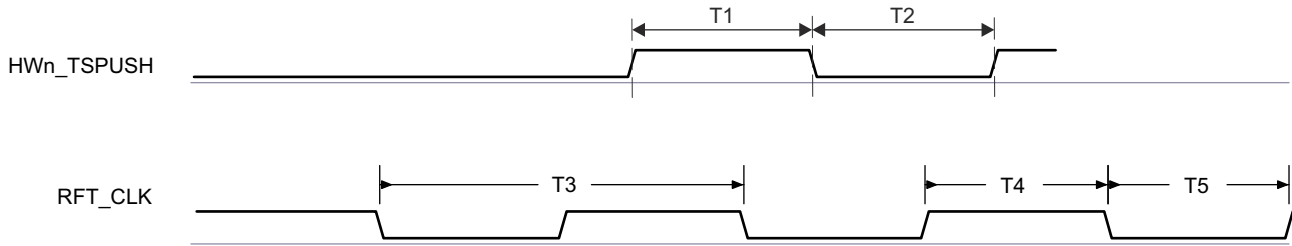
- (1) P = functional clock period in ns.
- (2) n = 0 to 3 in SYNcN\_OUT



图 7-97. CPTS Switching Characteristics

For more information, see *Navigator Subsystem (NAVSS)* section in *Data Movement Architecture (DMA)* chapter in the device TRM.

7.10.5.19 OSPI

For more details about features and additional description information on the device Octal Serial Peripheral Interface, see the corresponding sections within [Signal Descriptions](#) and *Detailed Description*.

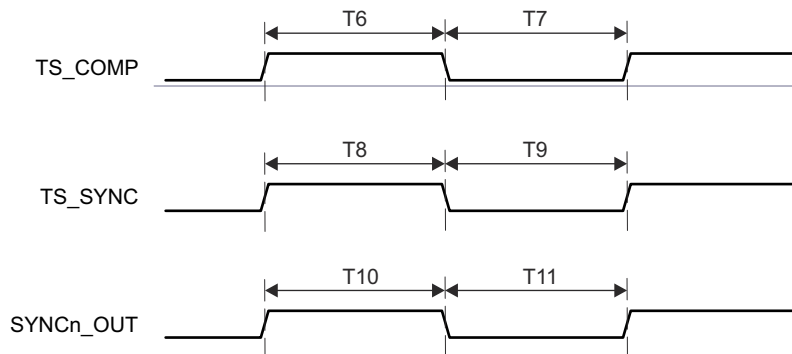
表 7-81 represents OSPI timing conditions.

表 7-81. OSPI Timing Conditions

PARAMETER			MIN	MAX	UNIT
<b>INPUT CONDITIONS</b>					
SR <sub>i</sub>	Input slew rate	3.3 V	2	6	V/ns
		All other modes	1	6	V/ns
<b>OUTPUT CONDITIONS</b>					

**表 7-81. OSPI Timing Conditions (continued)**

PARAMETER			MIN	MAX	UNIT
$C_L$	Output load capacitance	All modes	3	10	pF
<b>PCB CONNECTIVITY REQUIREMENTS</b>					
$t_d$ (Trace Delay)	Propagation delay OSPI_CLK trace	No Loopback; Internal Pad Loopback		450	ps
	Propagation delay OSPI_LBCLKO trace	External Board Loopback	$2*L-30^{(2)}$	$2*L+30^{(2)}$	ps
	Propagation delay OSPI_DQS trace	DQS	$L-30^{(2)}$	$L+30^{(2)}$	ps
$t_d$ (Trace Mismatch Delay)	Propagation delay mismatch OSPI_D[i:0] <sup>(1)</sup> , OSPI_CS <i>n</i> relative to OSPI_CLK	All modes		60	ps

- (1)  $i$  in D[i:0] = 0 to 7 for OSPI0;  $i$  in [i:0] = 3 for OSPI1  
 (2)  $L$  = Propagation delay of OSPI\_CLK trace

### 7.10.5.19.1 OSPI0 PHY Mode

#### 7.10.5.19.1.1 OSPI With Data Training

注

I/O timing requirements and switching characteristics are not applicable when OSPI is used with data training. Follow the [OSPI and QSPI Board Design and Layout Guidelines](#) section to ensure proper operation.

##### 7.10.5.19.1.1.1 OSPI Switching Characteristics – Data Training

PARAMETER	DESCRIPTION	MODE	MIN	MAX	UNIT
$t_{c(\text{CLK})}$	Cycle time, CLK	DDR, 1.8V	6		ns
		DDR, 3.3V	7.5		ns
$t_{c(\text{CLK})}$	Cycle time, CLK	SDR, 1.8V	6		ns
		SDR, 3.3V	7.5		ns

#### 7.10.5.19.1.2 OSPI Without Data Training

注

The I/O Timings provided in this section are only applicable when data training is not implemented. Additionally, the I/O Timings are valid only for some OSPI usage modes when the corresponding DLL Delays are configured as described in [表 7-82](#) found in this section.

[セクション 7.10.5.19.1.2.4](#), [セクション 7.10.5.19.1.2.2](#), [セクション 7.10.5.19.1.2](#), and [セクション 7.10.5.19.1.2](#) present switching characteristics for OSPI DDR and SDR Mode.

##### 7.10.5.19.1.2.1 OSPI Timing Requirements – SDR Mode

**表 7-82. OSPI DLL Delay Mapping - SDR Timing Modes**

MODE	OSPI_PHY_CONFIGURATION_REG BIT FIELD	DELAY VALUE
All modes	PHY_CONFIG_TX_DLL_DELAY_FLD	0x0
	PHY_CONFIG_RX_DLL_DELAY_FLD	0x0

**表 7-83. OSPI Timing Requirements – SDR Mode**

NO.	PARAMETER	DESCRIPTION	MODE	MIN	MAX	UNIT
O21	$t_{su(D-LBCLK)}$	Setup time, D[i:0] valid before active LBCLK input (DQS) edge <sup>(1)</sup>	1.8V, External Board Loopback	0.6		ns
			3.3V, External Board Loopback	0.9		ns
O22	$t_{h(LBCLK-D)}$	Hold time, D[i:0] valid after active LBCLK input (DQS) edge <sup>(1)</sup>	1.8V, External Board Loopback	1.7		ns
			3.3V, External Board Loopback	2		ns

(1) i in [i:0] = 7 for OSPI0, i in [i:0] = 3 for OSPI1

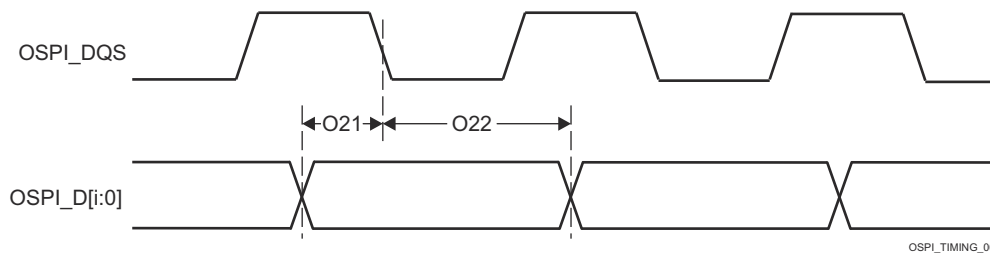

**表 7-98. OSPI Timing Requirements – SDR, External Loopback Clock**



7.10.5.19.1.2.2 OSPI Switching Characteristics – SDR Mode

NO.	PARAMETER	DESCRIPTION	MODE	MIN	MAX	UNIT
O7	$t_{c(CLK)}$	Cycle time, CLK	1.8V	7		ns
			3.3V	7.5		ns
O8	$t_{w(CLKL)}$	Pulse duration, CLK low		$-0.3+0.475*P$ (2)		ns
O9		Pulse duration, CLK high		$-0.3+0.475*P$ (2)		ns
O10	$t_{d(CSn-CLK)}$	Delay time, CSn[3:0] active edge to CLK rising edge	1.8V	$0.475 * P + 0.975 * M * R - 7$ (2) (3) (5)	$0.525 * P + 1.025 * M * R + 1$ (2) (3) (5)	ns
			3.3V	$0.475 * P + 0.975 * M * R - 7$ (2) (3) (5)	$0.525 * P + 1.025 * M * R + 1$ (2) (3) (5)	ns
O11	$t_{d(CLK-CSn)}$	Delay time, CLK rising edge to CSn inactive edge	1.8V	$0.475 * P + 0.975 * N * R - 1$ (2) (4) (5)	$0.525 * P + 1.025 * N * R + 1$ (2) (4) (5)	ns
			3.3V	$0.475 * P + 0.975 * N * R - 1$ (2) (4) (5)	$0.525 * P + 1.025 * N * R + 1$ (2) (4) (5)	ns
O12	$t_{d(CLK-D)}$	Delay time, CLK active edge to D[i:0] transition <sup>(1)</sup>	1.8V	-1.16	1.25	ns
			3.3V	-1.33	1.51	ns

- (1) i in [i:0] = 7 for OSPI0, i in [i:0] = 3 for OSPI1
- (2) P = CLK cycle time = SCLK period
- (3) M = OSPI\_DEV\_DELAY\_REG[D\_INIT\_FLD]
- (4) N = OSPI\_DEV\_DELAY\_REG[D\_AFTER\_FLD]
- (5) R = refclk



図 7-99. OSPI Switching Characteristics – SDR

セクション 7.10.5.19.1.2.3, セクション 7.10.5.19.1.2.1, セクション 7.10.5.19.1.2.2, セクション 7.10.5.19.1.2.2, and 図 7-98 presents timing requirements for OSPI DDR and SDR Mode.

7.10.5.19.1.2.3 OSPI Timing Requirements – DDR Mode

表 7-84. OSPI DLL Delay Mapping - DDR Timing Modes

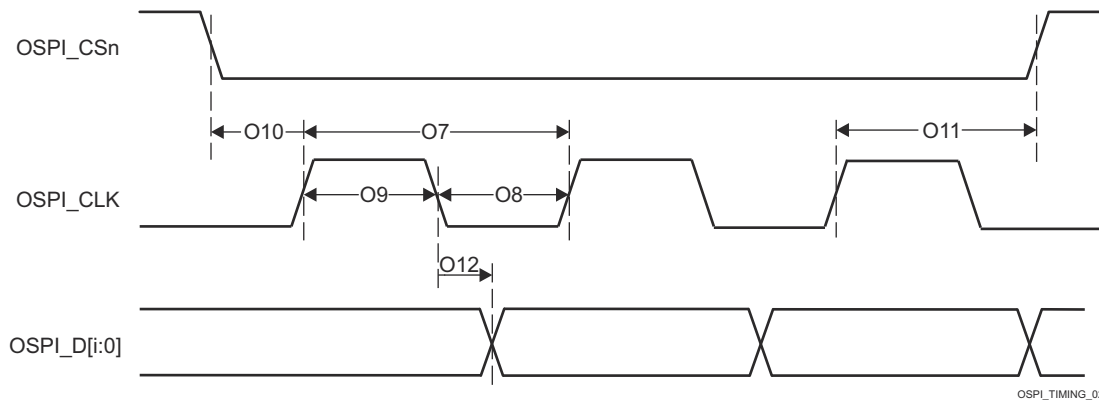
MODE	OSPI_PHY_CONFIGURATION_REG BIT FIELD	OSPI0	OSPI1
		DELAY VALUE	
<b>TRANSMIT</b>			
1.8V	PHY_CONFIG_TX_DLL_DELAY_FLD	0x54	0x54
3.3V	PHY_CONFIG_TX_DLL_DELAY_FLD	0x55	0x5C
<b>RECEIVE</b>			

**表 7-84. OSPI DLL Delay Mapping - DDR Timing Modes (continued)**

MODE	OSPI_PHY_CONFIGURATION_REG BIT FIELD	OSPI0	OSPI1
		DELAY VALUE	
1.8V, DQS	PHY_CONFIG_RX_DLL_DELAY_FLD	0x23	0x29
3.3V, DQS	PHY_CONFIG_RX_DLL_DELAY_FLD	0x47	0x42
All other modes	PHY_CONFIG_RX_DLL_DELAY_FLD	0x0	0x0

**表 7-85. OSPI Timing Requirements – DDR Mode**

NO.	PARAMETER	DESCRIPTION	MODE	MIN	MAX	UNIT
O15	$t_{su(D-LBCLK)}$	Setup time, D[i:0] valid before active LBCLK (DQS) edge <sup>(1)</sup>	1.8V, External Board Loopback	0.52		ns
			3.3V, External Board Loopback	1.97		ns
O16	$t_{h(LBCLK-D)}$	Hold time, D[i:0] valid after active LBCLK (DQS) edge <sup>(1)</sup>	1.8V, External Board Loopback	1.24 <sup>(2)</sup>		ns
			3.3V, External Board Loopback	1.44 <sup>(2)</sup>		ns
O17	$t_{su(D-DQS)}$	Setup time, DQS edge to D[i:0] transition <sup>(1)</sup>	1.8V, DQS	-0.46		ns
			3.3V, DQS	-0.66		ns
O18	$t_{h(DQS-D)}$	Hold time, DQS edge to D[i:0] transition <sup>(1)</sup>	1.8V, DQS	3.59		ns
			3.3V, DQS	8.89		ns

(1) i in [i:0] = 7 for OSPI0, i in [i:0] = 3 for OSPI1

(2) This Hold time requirement is larger than the Hold time provided by a typical flash device. Therefore, the trace length between the SoC and flash device must be sufficiently long enough to ensure that the Hold time is met at the SoC. Refer to [OSPI and QSPI Board Design and Layout Guidelines](#) for more details.

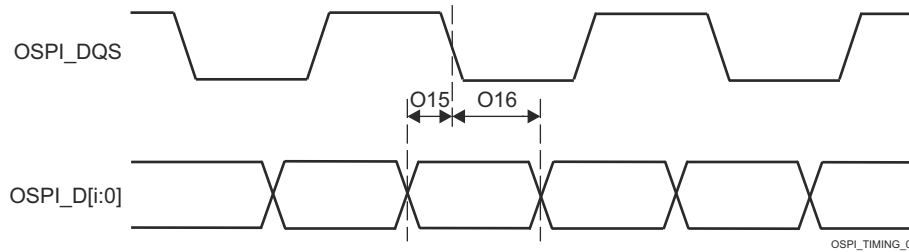

**图 7-100. OSPI Timing Requirements – DDR, External Loopback Clock and DQS**

**7.10.5.19.1.2.4 OSPI Switching Characteristics – DDR Mode**

NO.	PARAMETER	DESCRIPTION	MODE	MIN	MAX	UNIT
O1	$t_{c(CLK)}$	Cycle time, CLK	1.8V	19		ns
			3.3V	19		ns
O2	$t_{w(CLKL)}$	Pulse duration, CLK low		$0.475 * P - 0.3$ <sup>(2)</sup>		ns
O3	$t_{w(CLKH)}$	Pulse duration, CLK high		$0.475 * P - 0.3$ <sup>(2)</sup>		ns
O4	$t_{d(CLK-CSn)}$	Delay time, CSn active edge to CLK rising edge	1.8V	$0.475 * P + 0.975 * M * R - 7$ <sup>(2) (3) (5)</sup>	$0.525 * P + 1.025 * M * R + 1$ <sup>(2) (3) (5)</sup>	ns
			3.3V	$0.475 * P + 0.975 * M * R - 7$ <sup>(2) (3) (5)</sup>	$0.525 * P + 1.025 * M * R + 1$ <sup>(2) (3) (5)</sup>	ns
O5	$t_{d(CLK-CSn)}$	Delay time, CLK rising edge to CSn inactive edge	1.8V	$0.475 * P + 0.975 * N * R - 7$ <sup>(2) (4) (5)</sup>	$0.525 * P + 1.025 * N * R + 1$ <sup>(2) (4) (5)</sup>	ns
			3.3V, OSPI0 DDR TX; 3.3V, OSPI1 DDR TX	$0.475 * P + 0.975 * N * R - 7$ <sup>(2) (4) (5)</sup>	$0.525 * P + 1.025 * N * R + 1$ <sup>(2) (4) (5)</sup>	ns

NO.	PARAMETER	DESCRIPTION	MODE	MIN	MAX	UNIT
O6	$t_{d(\text{CLK-D})}$	Delay time, CLK active edge to D[i:0] transition <sup>(1)</sup>	1.8V, OSPI0 DDR TX; 1.8V, OSPI1 DDR TX	-7.71	-1.56	ns
			3.3V, OSPI0 DDR TX; 3.3V, OSPI1 DDR TX	-7.71	-1.56	ns

- (1) i in [i:0] = 7 for OSPI0, i in [i:0] = 3 for OSPI1
- (2) P = CLK cycle time = SCLK period
- (3) N = OSPI\_DEV\_DELAY\_REG[D\_INIT\_FLD]
- (4) N = OSPI\_DEV\_DELAY\_REG[D\_AFTER\_FLD]
- (5) R = refclk

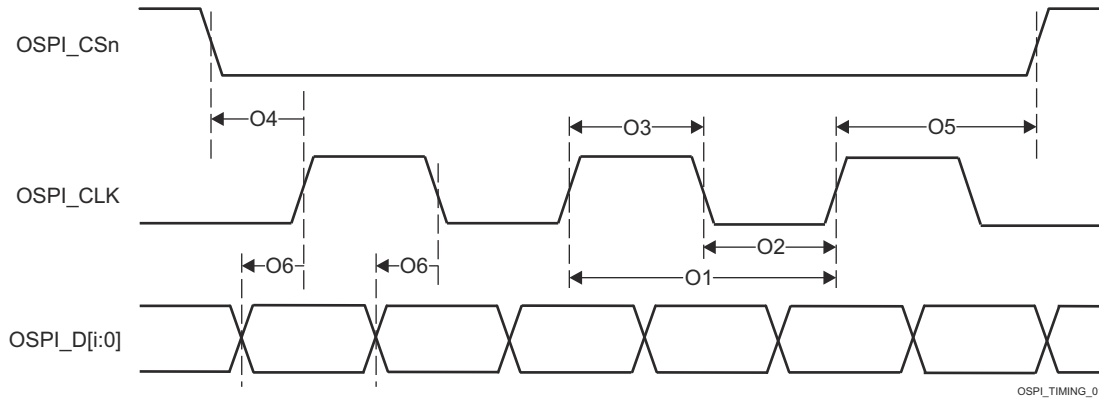

**7-101. OSPI Switching Characteristics – DDR**

### 7.10.5.19.2 OSPI0 Tap Mode

#### 7.10.5.19.2.1 OSPI0 Tap SDR Timing

表 7-86, 图 7-102, 表 7-87, and 图 7-103 present timing requirements and switching characteristics for OSPI0 Tap SDR Mode.

**表 7-86. OSPI0/1 Timing Requirements – Tap SDR Mode**

see 图 7-102

NO.		MODE	MIN	MAX	UNIT
O19	$t_{su(D-CLK)}$	Setup time, OSPI0/1_D[7:0] valid before active OSPI0/1_CLK edge	(10.4 - (0.975T <sup>(1)</sup> R <sup>(2)</sup> ))		ns
O20	$t_{h(CLK-D)}$	Hold time, OSPI0/1_D[7:0] valid after active OSPI0/1_CLK edge	(-0.2 + (0.975T <sup>(1)</sup> R <sup>(2)</sup> ))		ns

- (1) T = OSPI\_RD\_DATA\_CAPTURE\_REG[DELAY\_FLD]  
 (2) R = refclk cycle time in ns

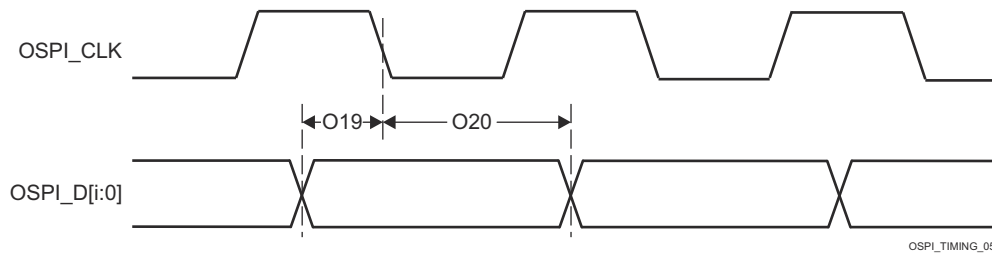

**图 7-102. OSPI0/1 Timing Requirements – Tap SDR, No Loopback**

表 7-87. OSPI0/1 Switching Characteristics – Tap SDR Mode

see 7-103

NO.	PARAMETER	MODE	MIN	MAX	UNIT
O7	$t_{c(CLK)}$	Cycle time, OSPI0/1_CLK	20		ns
O8	$t_{w(CLKL)}$	Pulse duration, OSPI0/1_CLK low	$((0.475P^{(1)}) - 0.3)$		ns
O9	$t_{w(CLKH)}$	Pulse duration, OSPI0/1_CLK high	$((0.475P^{(1)}) - 0.3)$		ns
O10	$t_{d(CSn-CLK)}$	Delay time, OSPI0/1_CSn[3:0] active edge to OSPI0/1_CLK rising edge	$((0.475P^{(1)}) + (0.975M^{(2)}R^{(4)}) - 1)$	$((0.525P^{(1)}) + (1.025M^{(2)}R^{(4)}) + 1)$	ns
O11	$t_{d(CLK-CSn)}$	Delay time, OSPI0/1_CLK rising edge to OSPI0/1_CSn[3:0] inactive edge	$((0.475P^{(1)}) + (0.975N^{(3)}R^{(4)}) - 1)$	$((0.525P^{(1)}) + (1.025N^{(3)}R^{(4)}) + 1)$	ns
O12	$t_{d(CLK-D)}$	Delay time, OSPI0/1_CLK active edge to OSPI0/1_D[7:0] transition	-2	2	ns

- (1) P = CLK cycle time = SCLK period in ns
- (2) M = OSPI\_DEV\_DELAY\_REG[D\_INIT\_FLD]
- (3) N = OSPI\_DEV\_DELAY\_REG[D\_AFTER\_FLD]
- (4) R = refclk cycle time in ns

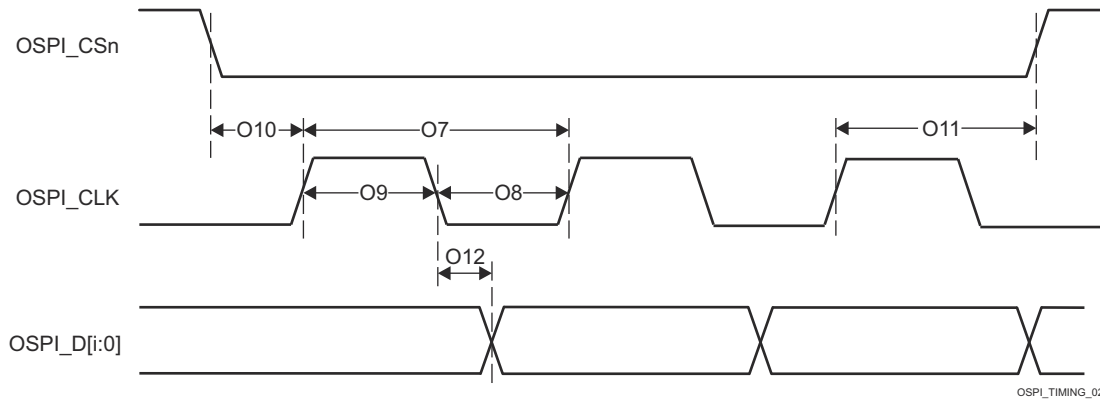

7-103. OSPI0/1 Switching Characteristics – Tap SDR, No Loopback

7.10.5.19.2.2 OSPI0 Tap DDR Timing

表 7-88, 图 7-104, 表 7-89, and 图 7-105 present timing requirements and switching characteristics for OSPI0 Tap DDR Mode.

表 7-88. OSPI0/1 Timing Requirements – Tap DDR Mode

see 图 7-104

NO.		MODE	MIN	MAX	UNIT
O13	$t_{su(D-CLK)}$	Setup time, OSPI0/1_D[7:0] valid before active OSPI0/1_CLK edge	(12.04 - (0.975T <sup>(1)</sup> R <sup>(2)</sup> ))		ns
O14	$t_{h(CLK-D)}$	Hold time, OSPI0/1_D[7:0] valid after active OSPI0/1_CLK edge	(1.84 + (0.975T <sup>(1)</sup> R <sup>(2)</sup> ))		ns

(1) T = OSPI\_RD\_DATA\_CAPTURE\_REG[DELAY\_FLD]

(2) R = refclk cycle time in ns



图 7-104. OSPI0/1 Timing Requirements – Tap DDR, No Loopback

ADVANCE INFORMATION

表 7-89. OSPI0/1 Switching Characteristics – Tap DDR Mode

see 図 7-105

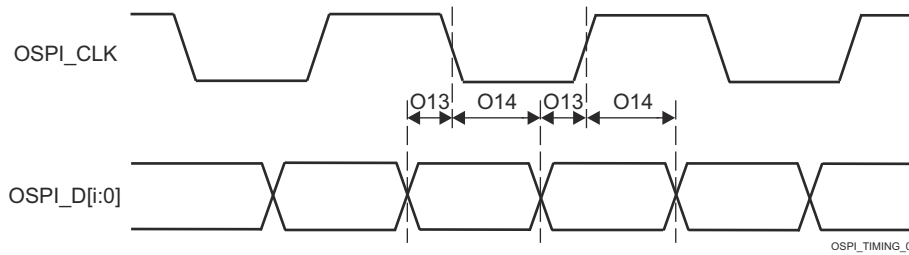
NO.	PARAMETER	MODE	MIN	MAX	UNIT
O1	$t_{c(CLK)}$ Cycle time, OSPI0/1_CLK		40		ns
O2	$t_{w(CLKL)}$ Pulse duration, OSPI0/1_CLK low		$((0.475P^{(1)}) - 0.3)$		ns
O3	$t_{w(CLKH)}$ Pulse duration, OSPI0/1_CLK high		$((0.475P^{(1)}) - 0.3)$		ns
O4	$t_{d(CSn-CLK)}$ Delay time, OSPI0/1_CSn[3:0] active edge to OSPI0/1_CLK rising edge		$((0.475P^{(1)}) + ((0.975M^{(2)}R^{(4)}) - 1)$	$((0.525P^{(1)}) + (1.025M^{(2)}R^{(4)}) + 1)$	ns
O5	$t_{d(CLK-CSn)}$ Delay time, OSPI0/1_CLK rising edge to OSPI0/1_CSn[3:0] inactive edge		$((0.475P^{(1)}) + (0.975N^{(3)}R^{(4)}) - 1)$	$((0.525P^{(1)}) + (1.025N^{(3)}R^{(4)}) + 1)$	ns
O6	$t_{d(CLK-D)}$ Delay time, OSPI0/1_CLK active edge to OSPI0/1_D[7:0] transition		$(-17.94 + (0.975T^{(5)}R^{(4)}))$	$(-1.56 + (1.025T^{(5)}R^{(4)}))$	ns

- (1) P = CLK cycle time = SCLK period in ns
- (2) M = OSPI\_DEV\_DELAY\_REG[D\_INIT\_FLD]
- (3) N = OSPI\_DEV\_DELAY\_REG[D\_AFTER\_FLD]
- (4) R = refclk cycle time in ns
- (5) T = OSPI\_RD\_DATA\_CAPTURE\_REG[DDR\_READ\_DELAY\_FLD]



図 7-105. OSPI0/1 Switching Characteristics – Tap DDR, No Loopback

### 7.10.5.20 OLDI

#### 7.10.5.20.1 OLDI Switching Characteristics

NO.	PARAMETER	MODE	MIN	MAX	UNIT
O1	LVDS Low-to-High Transition Time max	IOSET1	0.18	0.5	ns
O2	LVDS high-to-low Transition Time max	IOSET1	0.18	0.5	ns
O3	Transmitter Output Bit Width min	IOSET1	1	1	UI
O4	Transmitter Pulse Positions – Normalized	IOSET1	0.25	0.75	ns
O5	Variation in transmitter pulse position across Bit 7:0 pulse positions	IOSET1	-0.06	0.06	ns
O6	TxOut Channel to Channel Skew	IOSET1		110	ns
O7	Transmitter Jitter Cycle-to-Cycle	IOSET1	0.028	0.035	ns
O8	Input Total Jitter Tolerance (Includes data to clock skew, pulse position variation.)	IOSET1		0.25	ns

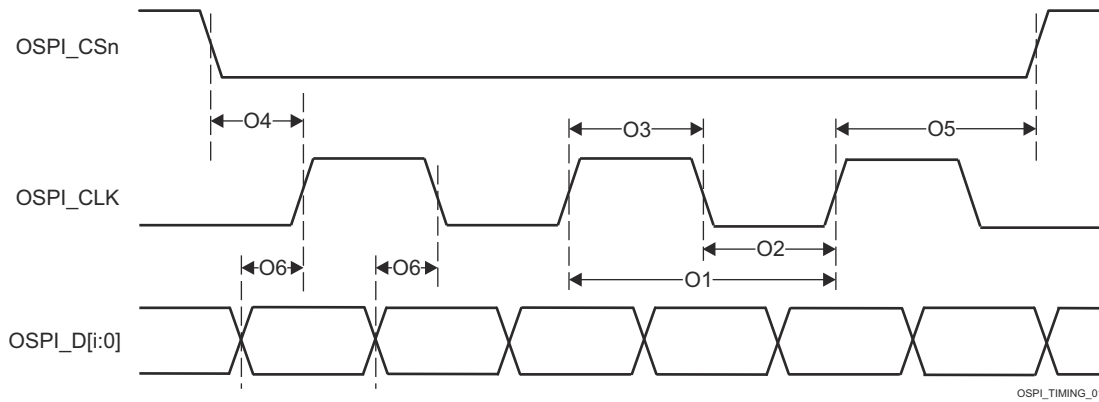
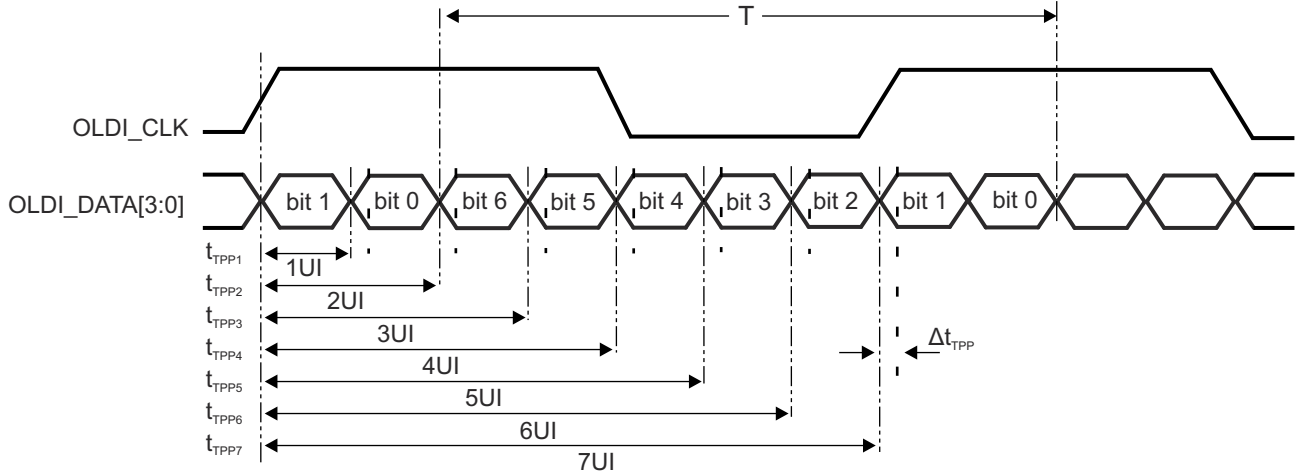

7-106. OLDI Transmitter Pulse Positions

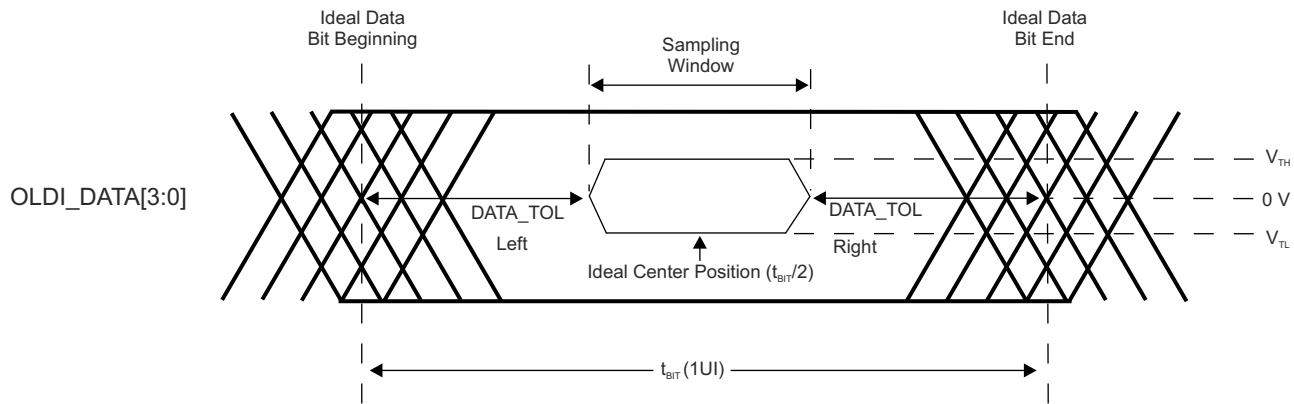

7-107. OLDI Data Output Jitter

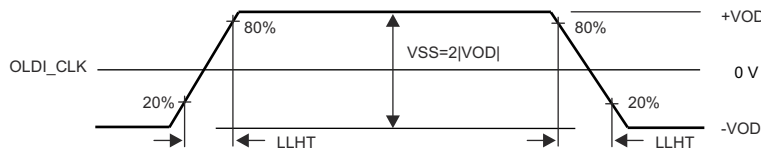

7-108. LVDS Output Transition Times

For more information, see *Display Subsystem (DSS) and Peripherals* section in *Peripherals* chapter in the device TRM.

### 7.10.5.21 PCIE

The PCI-Express Subsystem is compliant with the PCIe® Base Specification, Revision 4.0. Refer to the specification for timing details.

For more details about features and additional description information on the device Peripheral Component Interconnect Express, see the corresponding sections within [Signal Descriptions](#) and *Detailed Description*.

For more information, see *Peripheral Component Interconnect Express (PCIe) Subsystem* section in *Peripherals* chapter in the device TRM.



### 7.10.5.22 Timers

For more details about features and additional description information on the device Timers, see the corresponding sections within [Signal Descriptions](#) and *Detailed Description*.

表 7-90 represents Timers timing conditions.

表 7-90. Timers Timing Conditions

PARAMETER	DESCRIPTION	MODE	MIN	MAX	UNIT
<b>INPUT CONDITIONS</b>					
SR <sub>i</sub>	Input slew rate	CAPTURE	0.5	5	V/ns
<b>OUTPUT CONDITIONS</b>					
C <sub>L</sub>	Output load capacitance	PWM	2	10	pF

セクション 7.10.5.22.1, セクション 7.10.5.22.2 and 図 7-109 present timings and switching characteristics of the Timers.

#### 7.10.5.22.1 Timing Requirements for Timers

NO.	PARAMETER	DESCRIPTION	MODE	MIN	MAX	UNIT
T1	t <sub>w(TINPH)</sub>	Pulse duration, high	CAPTURE	2.5 + 4P <sup>(1)</sup>		ns
T2	t <sub>w(TINPL)</sub>	Pulse duration, low	CAPTURE	2.5 + 4P <sup>(1)</sup>		ns

(1) P = functional clock period in ns.

#### 7.10.5.22.2 Switching Characteristics for Timers

NO.	PARAMETER	DESCRIPTION	MODE	MIN	MAX	UNIT
T3	t <sub>w(TOUTH)</sub>	Pulse duration, high	PWM	-2.5 + 4P <sup>(1)</sup>		ns
T4	t <sub>w(TOUTL)</sub>	Pulse duration, low	PWM	-2.5 + 4P <sup>(1)</sup>		ns

(1) P = functional clock period in ns.



图 7-109. Timer Timing

For more information, see *Timers* section in *Peripherals* chapter in the device TRM.

### 7.10.5.23 UART

For more details about features and additional description information on the device Universal Asynchronous Receiver Transmitter, see the corresponding sections within , [Signal Descriptions](#) and *Detailed Description*.

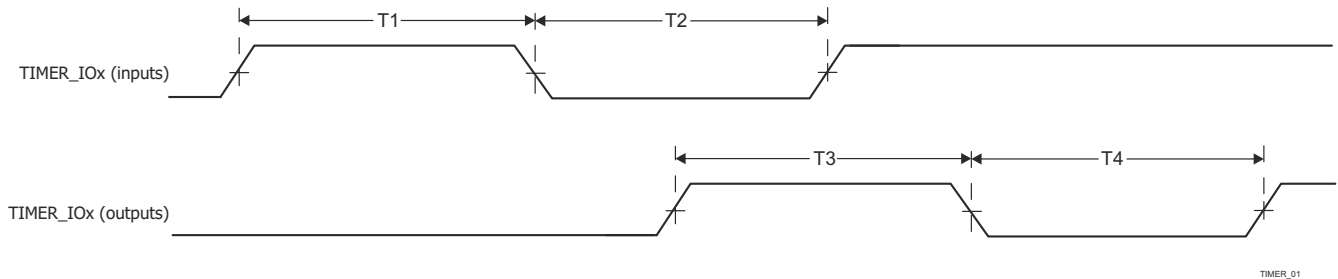
表 7-91 represents UART timing conditions.

表 7-91. UART Timing Conditions

PARAMETER	DESCRIPTION	MIN	MAX	UNIT
<b>INPUT CONDITIONS</b>				
SR <sub>I</sub>	Input slew rate	0.5	5	V/ns
<b>OUTPUT CONDITIONS</b>				
C <sub>L</sub>	Output load capacitance	1	30 <sup>(1)</sup>	pF

(1) This value represents an absolute maximum load capacitance. As the UART baud rate increases, it may be necessary to reduce the load capacitance to a value less than this maximum limit to provide enough timing margin for the attached device. The output rise/fall times increase as capacitive load increases, which decreases the time data is valid for the receiver of the attached devices. Therefore, it is important to understand the minimum data valid time required by the attached device at the operating baud rate. Then use the device IBIS models to verify the actual load capacitance on the UART signals does not increase the rise/fall times beyond the point where the minimum data valid time of the attached device is violated.

セクション 7.10.5.23.1, セクション 7.10.5.23.2, and 図 7-110 present timing requirements and switching characteristics for UART interface.

7.10.5.23.1 Timing Requirements for UART

NO.	PARAMETER	DESCRIPTION	MODE	MIN	MAX	UNIT
4	t <sub>w(rxds)</sub>	Pulse width, receive data bit, high or low		0.95U <sup>(1)</sup> (2)	1.05U <sup>(1)</sup> (2)	ns
5	t <sub>w(rxds)</sub>	Pulse width, receive start bit, low		0.95U <sup>(1)</sup> (2)		ns

- (1) U = UART baud time = 1/Programmed baud rate
- (2) This value defines the data valid time, where the input voltage is required to be above V<sub>IH</sub> or below V<sub>IL</sub>.

7.10.5.23.2 UART Switching Characteristics

NO.	PARAMETER	DESCRIPTION	MIN	MAX	UNIT
	f <sub>(baud)</sub>	Maximum programmable baud rate		12	Mbps
2	t <sub>w(TX)</sub>	Pulse width, transmit data bit, high or low	U - 2 <sup>(1)</sup>	U + 2 <sup>(1)</sup>	ns
3	t <sub>w(RTS)</sub>	Pulse width, transmit start bit, high or low	U - 2 <sup>(1)</sup>		ns

- (1) U = UART baud time = 1/Programmed baud rate



図 7-110. UART Timing

For more information, see *Universal Asynchronous Receiver/Transmitter (UART)* section in *Peripherals* chapter in the device TRM.

7.10.5.24 USB

The USB 2.0 subsystem is compliant with the Universal Serial Bus (USB) Specification, revision 2.0. Refer to the specification for timing details.

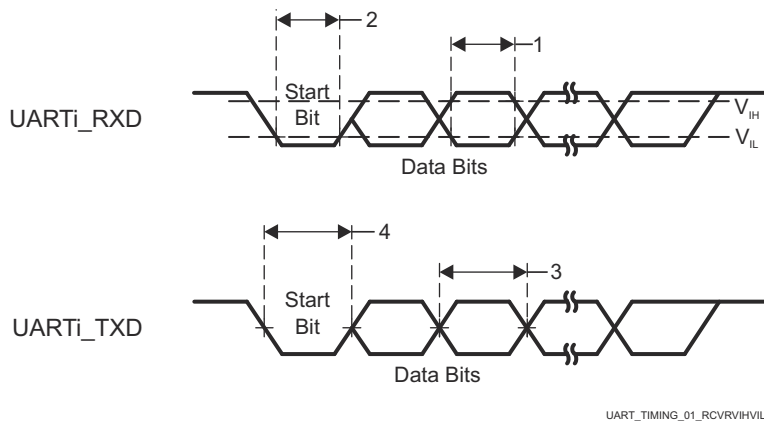
The USB 3.1 GEN1 Dual-Role Device Subsystem is compliant with the Universal Serial Bus (USB) 3.1 Specification, revision 1.0. Refer to the specification for timing details.

For more details about features and additional description information on the device Universal Serial Bus Subsystem (USB), see the corresponding sections within [Signal Descriptions](#) and *Detailed Description*.

### 7.10.6 Emulation and Debug

#### 7.10.6.1 Trace

表 7-92. Trace Timing Conditions

PARAMETER		MIN	MAX	UNIT
<b>OUTPUT CONDITIONS</b>				
$C_L$	Output load capacitance	2	5	pF
<b>PCB CONNECTIVITY REQUIREMENTS</b>				
$t_d$ (Trace Mismatch)	Propagation delay mismatch across all traces		200	ps

表 7-93 和 图 7-111 assume testing over the recommended operating conditions and electrical characteristic conditions.

表 7-93. Trace Switching Characteristics

NO.	PARAMETER		MIN	MAX	UNIT
<b>1.8 V Mode</b>					
DBTR1	$t_c$ (TRC_CLK)	Cycle time, TRC_CLK	6.50		ns
DBTR2	$t_w$ (TRC_CLKH)	Pulse width, TRC_CLK high	2.50		ns
DBTR3	$t_w$ (TRC_CLKL)	Pulse width, TRC_CLK low	2.50		ns
DBTR4	$t_{osu}$ (TRC_DATAV-TRC_CLK)	Output setup time, TRC_DATA valid to TRC_CLK edge	0.81		ns
DBTR5	$t_{oh}$ (TRC_CLK-TRC_DATAI)	Output hold time, TRC_CLK edge to TRC_DATA invalid	0.81		ns
DBTR6	$t_{osu}$ (TRC_CTLV-TRC_CLK)	Output setup time, TRC_CTL valid to TRC_CLK edge	0.81		ns
DBTR7	$t_{oh}$ (TRC_CLK-TRC_CTLI)	Output hold time, TRC_CLK edge to TRC_CTL invalid	0.81		ns
<b>3.3 V Mode</b>					
DBTR1	$t_c$ (TRC_CLK)	Cycle time, TRC_CLK	9.75		ns
DBTR2	$t_w$ (TRC_CLKH)	Pulse width, TRC_CLK high	4.13		ns
DBTR3	$t_w$ (TRC_CLKL)	Pulse width, TRC_CLK low	4.13		ns
DBTR4	$t_{osu}$ (TRC_DATAV-TRC_CLK)	Output setup time, TRC_DATA valid to TRC_CLK edge	1.22		ns
DBTR5	$t_{oh}$ (TRC_CLK-TRC_DATAI)	Output hold time, TRC_CLK edge to TRC_DATA invalid	1.22		ns
DBTR6	$t_{osu}$ (TRC_CTLV-TRC_CLK)	Output setup time, TRC_CTL valid to TRC_CLK edge	1.22		ns
DBTR7	$t_{oh}$ (TRC_CLK-TRC_CTLI)	Output hold time, TRC_CLK edge to TRC_CTL invalid	1.22		ns



图 7-111. Trace Switching Characteristics

SPRS008\_Debug\_01

### 7.10.6.2 JTAG

For more details about features and additional description information on the device IEEE 1149.1 Standard–Test–Access Port, see the corresponding sections within [Signal Descriptions](#) and *Detailed Description*.

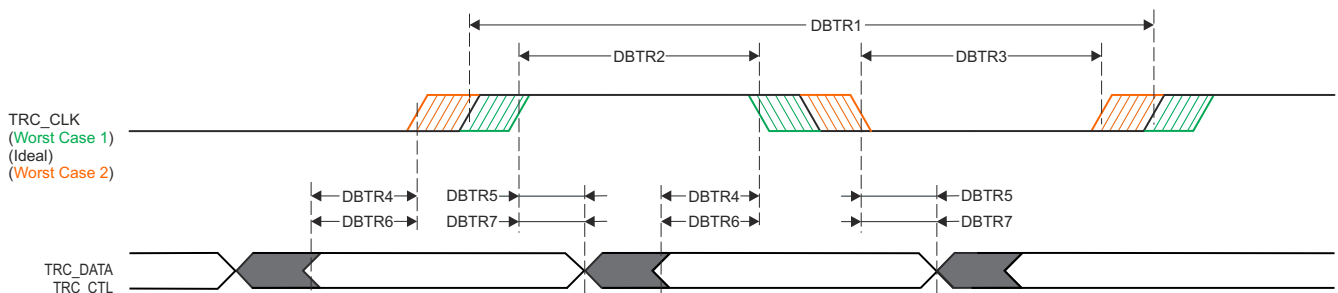
注

The JTAG signals are split across two IO power domains on the device. Timings parameters defined in this section only apply when the two IO power domains are operating at the same voltage and level-shifters are not inserted into the signal path. Values for the following timing parameters are not defined when operating the two IO power domains at different voltages since propagation delay through the device IO buffers differ when some are operating at 1.8 V while others are operating at 3.3 V. This effectively reduces timing margin beyond the values defined in this section. The JTAG interface is still expected to function when the two IO power domains are operated at different voltages, assuming the system designer has implemented appropriate level-shifters and the operating frequency is reduced to accommodate additional delay inserted by the level-shifters and IO buffers operating at different voltages.

**表 7-94. JTAG Timing Conditions**

PARAMETER		MIN	MAX	UNIT
<b>Input Conditions</b>				
SR <sub>I</sub>	Input slew rate	0.50	2.00	V/ns
<b>Output Conditions</b>				
C <sub>L</sub>	Output load capacitance	5	15	pF
<b>PCB CONNECTIVITY REQUIREMENTS</b>				
t <sub>d</sub> (Trace Delay)	Propagation delay of each trace	83.5	1000 <sup>(1)</sup>	ps
t <sub>d</sub> (Trace Mismatch Delay)	Propagation delay mismatch across all traces		100	ps

- (1) Maximum propagation delay associated with the JTAG signal traces has a significant impact on maximum TCK operating frequency. It may be possible to increase the trace delay beyond this value, but the operating frequency of TCK must be reduced to account for the additional trace delay.

#### 7.10.6.2.1 JTAG Electrical Data and Timing

セクション 7.10.6.2.1.1, セクション 7.10.6.2.1.2, and [図 7-112](#) assume testing over the recommended operating conditions and electrical characteristic conditions.

##### 7.10.6.2.1.1 JTAG Timing Requirements

See [図 7-112](#)

NO.			MIN	MAX	UNIT
J1	t <sub>C</sub> (TCK)	Cycle time minimum, TCK	46.5 <sup>(1)</sup>		ns
J2	t <sub>w</sub> (TCKH)	Pulse width minimum, TCK high	18.6 <sup>(2)</sup>		ns
J3	t <sub>w</sub> (TCKL)	Pulse width minimum, TCK low	18.6 <sup>(2)</sup>		ns
J4	t <sub>su</sub> (TDI-TCK)	Input setup time minimum, TDI valid to TCK high	4.5		ns
	t <sub>su</sub> (TMS-TCK)	Input setup time minimum, TMS valid to TCK high	4.5		ns
J5	t <sub>h</sub> (TCK-TDI)	Input hold time minimum, TDI valid from TCK high	2		ns
	t <sub>h</sub> (TCK-TMS)	Input hold time minimum, TMS valid from TCK high	2		ns

- (1) The maximum TCK operating frequency assumes the following timing requirements and switching characteristics for the attached debugger. The operating frequency of TCK must be reduced to provide appropriate timing margin if the debugger exceeds any of these assumptions.
- Minimum TDO setup time of 4.6 ns relative to the rising edge of TCK
  - TDI and TMS output delay in the range of –16.5 ns to 14.0 ns relative to the falling edge of TCK
- (2) P = TCK cycle time in ns

### 7.10.6.2.1.2 JTAG Switching Characteristics

See [7-112](#)

NO.	PARAMETER		MIN	MAX	UNIT
J6	$t_{d(TCKL-TDOI)}$	Delay time minimum, TCK low to TDO invalid	0		ns
J7	$t_{d(TCKL-TDOV)}$	Delay time maximum, TCK low to TDO valid		12	ns

- The JTAG signals are split across two IO power domains on the device. Timings parameters defined in this table only apply when the two IO power domains are operating at the same voltage. Values for these timing parameters are not defined when operating the two IO power domains at different voltages since propagation delay through the device IO buffers differ when some are operating at 1.8V while others are operating at 3.3V. This effectively reduces timing margin beyond the values defined in this table. The JTAG interface is still expected to function when the two IO power domains are operated at different voltages, assuming the system designer has implemented appropriate level shifters and the operating frequency is reduced to accommodate additional delay inserted by the level-shifters and IO buffers operating at different voltages.

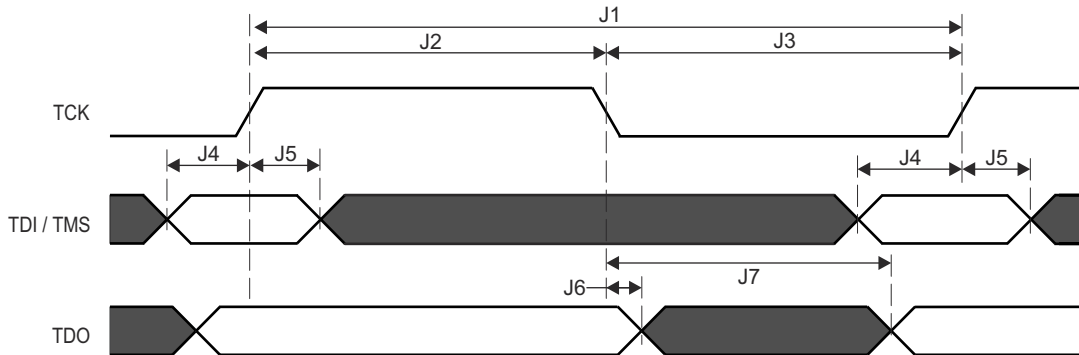

**7-112. JTAG Timing Requirements and Switching Characteristics**

## 8 Detailed Description

### 8.1 Overview

The TDA4VH/AH/VP-Q1 processor family is based on the evolutionary Jacinto 7 architecture, targeted at ADAS and Autonomous Vehicle (AV) applications and built on extensive market knowledge accumulated over a decade of TI's leadership in the ADAS processor market. The TDA4VH/AH/VP-Q1 provides high performance compute for both traditional and deep learning algorithms at industry leading power/performance ratios with a high level of system integration to enable scalability and lower costs for advanced automotive platforms supporting multiple sensor modalities in centralized ECUs or stand-alone sensors. Key cores include next generation DSP with scalar and vector cores, dedicated deep learning and traditional algorithm accelerators, latest Arm and GPU processors for general compute, an integrated next generation imaging subsystem (ISP), video codec, Ethernet hub and isolated MCU island. All protected by automotive grade safety and security hardware accelerators.

---

#### 注

For more information on features, subsystems, and architecture of superset device System on Chip (SoC), see the device TRM.

---

## 8.2 Processor Subsystems

### 8.2.1 Arm Cortex-A72

The device implements one dual-core Arm® Cortex®-A72 MPU, which is integrated inside the Compute Cluster, along with other modules. The Cortex-A72 cores are general-purpose processors that can be used for running customer applications.

The A72SS is built around the Arm Cortex-A72 MPCore (A72 cluster), which is provided by Arm and configured by TI. It is based on the symmetric multiprocessor (SMP) architecture, and thus it delivers high performance and optimal power management and debug capabilities.

The A72 processor is a multi-issue out-of-order superscalar execution engine with integrated L1 instruction and data caches, compatible with Armv8-A architecture. The Armv8-A architecture brings a number of new features. These include 64-bit data processing, extended virtual addressing and 64-bit general purpose registers.

For more information, see *Dual-A72 MPU Subsystem* section in *Processors and Accelerators* chapter in the device TRM.

### 8.2.2 Arm Cortex-R5F

The MCU\_ARMSS is a dual-core implementation of the Arm® Cortex®-R5F processor configured for split/lock operation. It also includes accompanying memories (L1 caches and tightly-coupled memories), standard Arm® CoreSight™ debug and trace architecture, integrated Vectored Interrupt Manager (VIM), ECC Aggregators, and various wrappers for protocol conversion and address translation for easy integration into the SoC.

For more information, see *Dual-R5F MCU Subsystem* section in *Processors and Accelerators* chapter in the device TRM.

### 8.2.3 DSP C71x

The TMS320C71x is the next-generation fixed and floating-point DSP platform. The C71x DSP is a new core in the Texas Instruments' DSP family. The C71x DSP supports vector signal processing, providing significant lift in DSP processing power over a broad range of general signal processing tasks in comparison to the C6x DSP family. In addition, the C71x provides several specialized functions which accelerate targeted functions by more than 30 times. Besides expanding vector processing capabilities, the new C71x core also incorporates advanced techniques to improve control code efficiency and ease of programming such as branch prediction, protected pipeline, precise exception and virtual memory management.

For more information, see *C71x DSP Subsystem* section in *Processors and Accelerators* chapter in the device TRM.

## 8.3 Accelerators and Coprocessors

### 8.3.1 GPU

The Graphics Processing Unit (GPU) accelerates 3-dimensional (3D) and 2-dimensional (2D) graphics and compute applications.

The GPU module is a scalable architecture which efficiently processes a number of different workload concurrently:

- 3D Graphic Workload, which involves vertex data and pixel data processing for rendering of 3D scenes.
- 2D Graphic Workload, which involves pixel data processing for rendering 2D objects.
- Compute Applications Workload, which involves general purpose data processing.

For more information, see *Graphics Accelerator (GPU)* section in *Processors and Accelerators* chapter in the device TRM.

### 8.3.2 VPAC

The Vision Pre-processing Accelerator (VPAC) is a set of common vision primitive functions, performing memory-to-memory (M2M) pixel data processing tasks, such as: color processing and enhancement, noise filtering, wide dynamic range (WDR) processing, lens distortion correction, pixel remap for dewarping, on-the-fly scale generation, on-the-fly pyramid generation. The VPAC offloads these common tasks from the main SoC processors (ARM, DSP, etc.), so these CPUs can be utilized for differentiated high-level algorithms. The VPAC is designed to support multiple cameras by working in time-multiplexing mode. The VPAC works as front end to vision processing and prepares frame/scales for further processing by other vision accelerators or processor cores in the SoC.

For more information, see *Vision Pre-processing Accelerator (VPAC)* section in *Processors and Accelerators* chapter in the device TRM.

### 8.3.3 DMPAC

The Depth and Motion Perception Accelerator (DMPAC) is a power efficient hardware accelerator that computes dense stereo depth maps (*depth*) and dense optical flow vectors (*motion*) from camera inputs.

The image/video sensor-based environmental perception (also known as scene understanding) is at the core of many emerging applications in automotive, industrial and consumer electronics. Typically, this involves detection of all objects in the scene along with their 3D position and motion with regards to the observer or the car by analyzing one or many related input video streams. Various computer vision algorithms are used to achieve these tasks.

A very robust method of obtaining the 3D depth from images is to use two cameras in a stereo setup - two cameras with known relative positions and camera parameters. The two images of the same scene, captured from two different camera poses/perspectives, are analyzed to find disparities among every pixel positions in the images. This is known as the Stereo Disparity map. The disparity values of every pixel can be used to obtain the 3D positions of the object/space they belong to via triangulation.

On the other hand, by analyzing two images from a single camera, captured at two different time instances (that is, two temporal frames in a video), one can determine where each pixel in a past frame moved to in the future frame. This is known as the Optical Flow vector. The flow vectors for each pixel position can be used to obtain 3D structure of the scene, identify moving objects and determine their relative speed and direction of motion.

The DMPAC is dedicated to the aforesaid image processing tasks. The stereo and optical flow processing is partitioned into two top level sub-blocks: the Dense Optical Flow (DOF) engine and the Stereo Disparity Engine (SDE). The DOF and SDE blocks share a common shared local memory, DMA, external messaging and control infrastructure.

For more information, see *Depth and Motion Perception Accelerator (DMPAC)* section in *Processors and Accelerators* chapter in the device TRM.



## 8.4 Other Subsystems

### 8.4.1 MSMC

The Multicore Shared Memory Controller (MSMC) forms the heart of the compute cluster (COMPUTE\_CLUSTER0) providing high-bandwidth resource access both to and from all of the connected processing elements and the rest of the system. MSMC serves as the data-movement backbone of the compute cluster.

For more information, see *Multicore Shared Memory Controller (MSMC)* section in *Device Configuration* chapter in the device TRM.

### 8.4.2 NAVSS

#### 8.4.2.1 NAVSS0

Main SoC Navigator Subsystem (NAVSS0) consists of DMA/Queue Management components – UDMA and Ring Accelerator (UDMASS), Peripherals (Module subsystem [MODSS]), Virtualization translation (VirtSS), and a North Bridge (NBSS).

#### 8.4.2.2 MCU\_NAVSS

MCU Navigator Subsystem (MCU NAVSS) has a subset of the modules of the main NAVSS and is instantiated in the MCU domain.

MCU Navigator Subsystem consists of DMA/Queue Management components – UDMA and Ring Accelerator (UDMASS), and Peripherals (Module subsystem [MODSS]).

For more information, see *Main Navigator Subsystem (NAVSS)* and *MCU Navigator Subsystem (MCU NAVSS)* sections in the device TRM.

### 8.4.3 PDMA Controller

The Peripheral DMA is a simple DMA which has been architected to specifically meet the data transfer needs of peripherals, which perform data transfers using memory mapped registers accessed via a standard non-coherent bus fabric. The PDMA module is intended to be located close to one or more peripherals which require an external DMA for data movement and is architected to reduce cost by using VBUSP interfaces and supporting only statically configured Transfer Request (TR) operations.

The PDMA is only responsible for performing the data movement transactions which interact with the peripherals themselves. Data which is read from a given peripheral is packed by a PDMA source channel into a PSI-L data stream which is then sent to a remote peer UDMA-P destination channel which then performs the movement of the data into memory. Likewise, a remote UDMA-P source channel fetches data from memory and transfers it to a peer PDMA destination channel over PSI-L which then performs the writes to the peripheral.

The PDMA architecture is intentionally heterogeneous (UDMA-P + PDMA) to right size the data transfer complexity at each point in the system to match the requirements of whatever is being transferred to or from. Peripherals are typically FIFO based and do not require multi-dimensional transfers beyond their FIFO dimensioning requirements, so the PDMA transfer engines are kept simple with only a few dimensions (typically for sample size and FIFO depth), hardcoded address maps, and simple triggering capabilities.

Multiple source and destination channels are provided within the PDMA which allow multiple simultaneous transfer operations to be ongoing. The DMA controller maintains state information for each of the channels and employs round-robin scheduling between channels in order to share the underlying DMA hardware.

For more information, see *PDMA Controller* section in *DMA Controllers* chapter in the device TRM.

### 8.4.4 Power Supply

The device requires 6 power supply types and 1 internal LDO connection type, see [Power Supply Signal Descriptions](#)

- Digital IO Voltages
- Digital Low Voltages
- Digital AVS Voltage

- Analog PHY & CLK Voltages
- Analog Low Voltages
- Efuse Programming Voltages
- LDO Bulk Filter Capacitors

Common device power supply input types can be grouped together into power rails. All power rails must be supplied by power resources designed to support the most stringent power supply voltage specification and total load current demands. Two recommended Power Distribution Networks (PDNs) have been defined that either combine or isolate MCU and Main domains, (refer to *Power Supply Mapping*).

It is possible that a few power supply inputs may not be needed in some systems. In such cases, all unused supply inputs, other than VPP\_CORE & VPP\_MCU, must be connected to a valid power rail with a proper voltage level in order to ensure device reliability (refer to [Recommended Operating Conditions](#)). The following examples are given for reference:

1. If MCU Island safety monitor or MCU Only low power processing are not used, then VDD\_MCU supply can be combined with the VDD\_CORE supply with compatible operating voltage specification.
2. If UHS-I SD Card or USB2.0 interface is not needed, then VDDSHV5 (MMC1 interface) and VDDA\_USB\_3P3 (USB PHY interface) can be combined with VDD\_IO\_3V3 digital IO power rail.
3. If General Purpose device type is used, then Efuse programming voltages VPP\_CORE & VPP\_MCU are not needed and should be left unconnected.

## 8.4.5 Peripherals

### 8.4.5.1 ADC

The Analog-to-Digital Converter (ADC) module contains a single 12-bit ADC which can be multiplexed to any 1 of 8 analog inputs (channels).

For more information, see *Analog-to-Digital Converter (ADC)* section in *Peripherals* chapter in the device TRM.

### 8.4.5.2 ATL

The Audio Tracking Logic (ATL) is used by HD Radio™ applications to synchronize the digital audio output to the baseband clock. This same IP can also be used generically to track errors between two reference signals (such as frame syncs) and generate a modulated clock output (using software-controlled cycle stealing) which averages to some desired frequency. This process can be used as a hardware assist for asynchronous sample rate conversion algorithms.

For more information, see *Audio Tracking Logic (ATL)* section in *Peripherals* chapter in the device TRM.

### 8.4.5.3 CSI

#### 8.4.5.3.1 Camera Streaming Interface Receiver (CSI\_RX\_IF) and MIPI DPHY Receiver (DPHY\_RX)

The integration of the CSI\_RX\_IF module allows the device to stream video inputs from multiple cameras to the image processing accelerator (VPAC) or to internal memory. The video input may also be retransmitted via the transmitter CSI (CSI\_TX\_IF) for debug and test purposes.

For more information, see *Camera Streaming Interface (CSI)* section in *Peripherals* chapter in the device TRM.

#### 8.4.5.3.2 Camera Streaming Interface Transmitter (CSI\_TX\_IF)

The integration of the CSI\_TX\_IF module allows the device to stream out video data from memory, or retransmit from the CSI receivers as an optional loopback output for diagnostics, debug, and test purposes.

For more information, see *Camera Streaming Interface (CSI)* section in *Peripherals* chapter in the device TRM.

### 8.4.5.4 CPSW2G

The two-port Gigabit Ethernet MAC (MCU\_CPSW0) subsystem provides Ethernet packet communication for the device and is configured in a similar manner as an Ethernet switch. MCU\_CPSW0 features the Reduced Gigabit Media Independent Interface (RGMII), Reduced Media Independent Interface (RMII), and the Management Data Input/Output (MDIO) interface for physical layer device (PHY) management.

For more information, see *Gigabit Ethernet Switch (CPSW0)* section in *Peripherals* chapter in the device TRM.

#### 8.4.5.5 CPSW9G

The 9-port Gigabit Ethernet Switch (CPSW0) subsystem provides Ethernet packet communication for the device and can be configured as an Ethernet switch. CPSW0 features the Serial Gigabit Media Independent Interface (SGMII), Reduced Gigabit Media Independent Interface (RGMII), Reduced Media Independent Interface (RMII) and the Management Data Input/Output (MDIO) interface for physical layer device (PHY) management.

For more information, see *Gigabit Ethernet Switch (MCU\_CPSW0)* section in *Peripherals* chapter in the device TRM.

#### 8.4.5.6 DCC

The Dual Clock Comparator (DCC) is used to determine the accuracy of a clock signal during the time execution of an application. Specifically, the DCC is designed to detect drifts from the expected clock frequency. The desired accuracy can be programmed based on calculation for each application. The DCC measures the frequency of a selectable clock source using another input clock as a reference.

For more information, see *Dual Clock Comparator (DCC)* section in *Peripherals* chapter in the device TRM.

#### 8.4.5.7 DDRSS

The DDR subsystem in this device comprises DDR controller, DDR PHY and wrapper logic to integrate these blocks in the device. The DDR subsystem is referred to as DDRSS0 and is used to provide an interface to external SDRAM devices which can be utilized for storing program or data. DDRSS0 is accessed via MSMC, and not directly through the system interconnect.

For more information, see *DDR Subsystem (DDRSS)* section in *Peripherals* chapter in the device TRM.

#### 8.4.5.8 DSS

The DSS is a flexible composition-enabled display subsystem, that supports multiple high resolution display outputs. It consists of one Display Controller (DISPC) and one Frame Buffer Decompression Core (FBDC). The DISPC supports a multi-layer blending and transparency for each of its display outputs. The DISPC also supports a write-back pipeline with scaling to enable memory-to-memory composition and/or to capture a display output for Ethernet video encoding.

For more information, see *Display Subsystem (DSS)* section in *Peripherals* chapter in the device TRM.

##### 8.4.5.8.1 DSI

The MIPI DSI v1.3.1 Controller (DSITX) implements the stream arbitration and low-level protocol layer functionalities required by MIPI DSI 1.3 standard. It supports up to 4 x 2.5 Gbps D-PHY data lanes in a single-link configuration and handles the byte lane mapping per use case (1, 2, 3, or 4-lanes). The accompanying DSI (Physical Layer) D-PHY module (DPHYTX) provides the video output interfacing by implementing a four-lane MIPI D-PHY transmitter.

For more information, see *Display Subsystem (DSS) and Display Peripherals* section in *Peripherals* chapter in the device TRM.

##### 8.4.5.8.2 eDP

The VESA DP1.4/eDP1.4 Compliant Transmitter Host Controller (EDP) can output up to 4 video streams (through Multiple Stream Transport / MST) and one audio stream through the 4-lane accompanying SerDes module. It provides up to 25.92 Gbps of application bandwidth. An additional eDP (Physical Layer) auxiliary PHY (AUXPHY) module implements a doubly-terminated differential pair required for 1 Mbps data rates over a long (15m) cable.

For more information, see *Display Subsystem (DSS) and Display Peripherals* section in *Peripherals* chapter in the device TRM.

#### 8.4.5.9 VPFE

The Video Processing Front End (VPFE) is an input interface module that receives raw (unprocessed) image/video data or YUV digital video data from external imaging peripherals (such as image sensors, video decoders, etc) and performs DMA transfers to store the captured data in the system DDR memory.

For more information, see *Video Processing Front End (VPFE)* section in *Peripherals* chapter in the device TRM.

#### 8.4.5.10 eCAP

The enhanced Capture (ECAP) module can be used for:

- Sample rate measurements of audio inputs
- Speed measurements of rotating machinery (for example, toothed sprockets sensed via Hall sensors)
- Elapsed time measurements between position sensor pulses
- Period and duty cycle measurements of pulse train signals
- Decoding current or voltage amplitude derived from duty cycle encoded current/voltage sensors.

For more information, see *Enhanced Capture (ECAP) Module* section in *Peripherals* chapter in the device TRM.

#### 8.4.5.11 EPWM

An effective PWM peripheral must be able to generate complex pulse width waveforms with minimal CPU overhead or intervention. It needs to be highly programmable and very flexible while being easy to understand and use. The EPWM unit described here addresses these requirements by allocating all needed timing and control resources on a per PWM channel basis. Cross coupling or sharing of resources has been avoided; instead, the EPWM is built up from smaller single channel modules with separate resources and that can operate together as required to form a system. This modular approach results in an orthogonal architecture and provides a more transparent view of the peripheral structure, helping users to understand its operation quickly.

In the further description the letter x within a signal or module name is used to indicate a generic EPWM instance on a device. For example, output signals EPWMxA and EPWMxB refer to the output signals from the EPWM\_x instance. Thus, EPWM1A and EPWM1B belong to EPWM1, EPWM2A and EPWM2B belong to EPWM2, and so forth.

Additionally, the EPWM integration allows this synchronization scheme to be extended to the capture peripheral modules (ECAP). The number of modules is device-dependent and based on target application needs. Modules can also operate stand-alone.

For more information, see *Enhanced Pulse Width Modulation (EPWM) Module* section in *Peripherals* chapter in the device TRM.

#### 8.4.5.12 ELM

The Error Location Module (ELM) is used with the GPMC. Syndrome polynomials generated on-the-fly when reading a NAND flash page and stored in GPMC registers are passed to the ELM. A host processor can then correct the data block by flipping the bits to which the ELM error-location outputs point.

When reading from NAND flash memories, some level of error-correction is required. In the case of NAND modules with no internal correction capability, sometimes referred to as *bare NANDs*, the correction process is delegated to the memory controller. ELM can be also used to support parallel NOR flash or NAND flash.

For more information, see *Error Location Module (ELM)* section in *Peripherals* chapter in the device TRM.

#### 8.4.5.13 ESM

The Error Signaling Module (ESM) aggregates safety-related events and/or errors from throughout the device into one location. It can signal both low and high priority interrupts to a processor to deal with a safety event and/or manipulate an I/O error pin to signal an external hardware that an error has occurred. Therefore an external controller is able to reset the device or keep the system in safe, known state.

For more information, see *Error Signaling Module (ESM)* section in *Peripherals* chapter in the device TRM.

#### 8.4.5.14 eQEP

The Enhanced Quadrature Encoder Pulse (EQEP) peripheral is used for direct interface with a linear or rotary incremental encoder to get position, direction and speed information from a rotating machine for use in high performance motion and position control system. The disk of an incremental encoder is patterned with a single track of slots patterns. These slots create an alternating pattern of dark and light lines. The disk count is defined as the number of dark/light line pairs that occur per revolution (lines per revolution). As a rule, a second track is added to generate a signal that occurs once per revolution (index signal: QEPI), which can be used to indicate an absolute position. Encoder manufacturers identify the index pulse using different terms such as index, marker, home position and zero reference.

For more information, see *Enhanced Quadrature Encoder Pulse (EQEP) Module* section in *Peripherals* chapter in the device TRM.

#### 8.4.5.15 GPIO

The General-Purpose Input/Output (GPIO) peripheral provides dedicated general-purpose pins that can be configured as either inputs or outputs. When configured as an output, the user can write to an internal register to control the state driven on the output pin. When configured as an input, user can obtain the state of the input by reading the state of an internal register.

In addition, the GPIO peripheral can produce host CPU interrupts and DMA synchronization events in different interrupt/event generation modes.

For more information, see *General-Purpose Interface (GPIO)* section in *Peripherals* chapter in the device TRM.

#### 8.4.5.16 GPMC

The General-Purpose Memory Controller is a unified memory controller dedicated for interfacing with external memory devices like:

- Asynchronous SRAM-like memories and application-specific integrated circuit (ASIC) devices
- Asynchronous, synchronous, and page mode (available only in non-multiplexed mode) burst NOR flash devices
- NAND flash
- Pseudo-SRAM devices

For more information, see *General-Purpose Memory Controller (GPMC)* section in *Peripherals* chapter in the device TRM.

#### 8.4.5.17 Hyperbus

The Hyperbus module is a part of the device Flash Subsystem (FSS).

The Hyperbus module is low pin count memory interface that provides high read/write performance. The Hyperbus module connects to hyperbus memory (HyperFlash or HyperRAM) and uses simple hyperbus protocol for read and write transactions.

There is one Hyperbus™ module inside the device. The Hyperbus module includes one Hyperbus Memory Controller (HBMC).

For more information, see *Hyperbus Interface* section in *Peripherals* chapter in the device TRM.

#### 8.4.5.18 I2C

The device contains ten multimaster Inter-Integrated Circuit (I2C) controllers each of which provides an interface between a local host (LH), such as an Arm or a Digital Signal Processor (DSP), and any I<sup>2</sup>C-bus-compatible device that connects via the I<sup>2</sup>C serial bus. External components attached to the I<sup>2</sup>C bus can serially transmit and receive up to 8 bits of data to and from the LH device through the 2-wire I<sup>2</sup>C interface.

Each multimaster I2C module can be configured to act like a slave or master I<sup>2</sup>C-compatible device.

The WKUP\_I2C0, MCU\_I2C0, I2C0, and I2C1 controllers have dedicated I<sup>2</sup>C compliant open drain buffers, and support high speed mode (up to 3.4 Mbps in 1.8 V mode and up to 400 kbps in 3.3 V mode). The MCU\_I2C1,

I2C2, I2C3, I2C4, I2C5, and I2C6 controllers are multiplexed with standard LVCMOS I/O, connected to emulate open drain, and support fast mode (up to 400 kbps in 1.8 V/3.3 V mode). The I2C emulation is achieved by configuring the LVCMOS buffers to output Hi-Z instead of driving high when transmitting logic 1.

For more information, see *Inter-Integrated Circuit (I2C) Interface* section in *Peripherals* chapter in the device TRM.

#### 8.4.5.19 I3C

The device contains three Improved Inter-Integrated Circuit (I3C) controllers each of which provides an interface between a local host (LH), such as an Arm, and any I3C-bus-compatible device that connects via the I3C serial bus.

For more information, see *Improved Inter-Integrated Circuit (I3C) Interface* section in *Peripherals* chapter in the device TRM.

#### 8.4.5.20 MCAN

The Controller Area Network (CAN) is a serial communications protocol which efficiently supports distributed real-time control. CAN has high immunity to electrical interference. In a CAN network, many short messages are broadcast to the entire network, which provides for data consistency in every node of the system.

The MCAN module supports both classic CAN and CAN FD (CAN with Flexible Data-Rate) specifications. CAN FD feature allows high throughput and increased payload per data frame. The classic CAN and CAN FD devices can coexist on the same network without any conflict.

For more information, see *Modular Controller Area Network (MCAN)* section in *Peripherals* chapter in the device TRM.

#### 8.4.5.21 MCASP

The MCASP functions as a general-purpose audio serial port are optimized to the requirements of various audio applications. The MCASP module can operate in both transmit and receive modes. The MCASP is useful for time-division multiplexed (TDM) stream, Inter-IC Sound (I2S) protocols reception and transmission as well as for an inter-component digital audio interface transmission (DIT). The MCASP has the flexibility to gluelessly connect to a Sony/Philips digital interface (S/PDIF) transmit physical layer component.

Although inter-component digital audio interface reception (DIR) mode (this is, S/PDIF stream receiving) is not natively supported by the MCASP module, a specific TDM mode implementation for the MCASP receivers allows an easy connection to external DIR components (for example, S/PDIF to I2S format converters).

For more information, see *Multichannel Audio Serial Port (MCASP)* section in *Peripherals* chapter in the device TRM.

#### 8.4.5.22 MCRC Controller

VBUSM CRC controller is a module which is used to perform CRC (Cyclic Redundancy Check) to verify the integrity of a memory system. A signature representing the contents of the memory is obtained when the contents of the memory are read into MCRC Controller. The responsibility of MCRC controller is to calculate the signature for a set of data and then compare the calculated signature value against a predetermined good signature value. MCRC controller provides four channels to perform CRC calculation on multiple memories in parallel and can be used on any memory system. Channel 1 can also be put into data trace mode, where MCRC controller compresses each data being read through CPU read data bus.

For more information, see *MCRC Controller* section in *Interprocessor Communication* chapter in the device TRM.

#### 8.4.5.23 MCSPI

The MCSPI module is a multichannel transmit/receive, master/slave synchronous serial bus.

There are total of eleven MCSPI modules in the device.

For more information, see *Multichannel Serial Peripheral Interface (MCSPi)* section in *Peripherals* chapter in the device TRM.

#### **8.4.5.24 MMC/SD**

The MMCSD Host Controller provides an interface to eMMC 5.1 (embedded MultiMedia Card), SD 4.10 (Secure Digital), and SDIO 4.0 (Secure Digital IO) devices. The MMCSD Host Controller deals with MMC/SD/SDIO protocol at transmission level, data packing, adding cyclic redundancy checks (CRCs), start/end bit insertion, and checking for syntactical correctness.

For more information, see *Multimedia Card/Secure Digital (MMC/SD) Interface* section in *Peripherals* chapter in the device TRM.

#### **8.4.5.25 OSPI**

The Octal Serial Peripheral Interface (OSPI) module is a kind of Serial Peripheral Interface (SPI) module which allows single, dual, quad or octal read and write access to external flash devices. This module has a memory mapped register interface, which provides a direct memory interface for accessing data from external flash devices, simplifying software requirements.

The OSPI module is used to transfer data, either in a memory mapped direct mode (for example a processor wishing to execute code directly from external flash memory), or in an indirect mode where the module is set-up to silently perform some requested operation, signalling its completion via interrupts or status registers. For indirect operations, data is transferred between system memory and external flash memory via an internal SRAM which is loaded for writes and unloaded for reads by a device master at low latency system speeds. Interrupts or status registers are used to identify the specific times at which this SRAM should be accessed using user programmable configuration registers.

For more information, see *Octal Serial Peripheral Interface (OSPI)* section in *Peripherals* chapter in the device TRM.

#### **8.4.5.26 PCIE**

The Peripheral Component Interconnect Express (PCIe) subsystem is built around a multi-lane dual-mode PCIe controller that provides low pin-count, high reliability, and high-speed data transfers at rates of up to 8.0 Gbps per lane for serial links on backplanes and printed wiring boards.

For more information, see *Peripheral Component Interconnect Express (PCIe) Subsystem* section in *Peripherals* chapter in the device TRM.

#### **8.4.5.27 SerDes**

SerDes'es goal is to convert device (SoC) parallel data into serialized data that can be output over a highspeed electrical interface. In the opposite direction, SerDes converts high-speed serial data into parallel data that can be processed by the device. To this end, the SerDes contains a variety of functional blocks to handle both the external analog interface as well as the internal digital logic.

For more information, see *Serializer/Deserializer (SerDes)* section in *Peripherals* chapter in the device TRM.

#### **8.4.5.28 WWDT**

The Windowed Watchdog Timer provides timer functionality for operating systems and for benchmarking code. The module incorporates several counters, which define the timebases needed for scheduling in the operating system. The module is implemented with an RTI module, but only WWDT is supported.

This module is specifically designed to fulfill the requirements for OSEK (“Offene Systeme und deren Schnittstellen für die Elektronik im Kraftfahrzeug”; “Open Systems and the Corresponding Interfaces for Automotive Electronics”) as well as OSEK/Time compliant operating systems.

For more information, see *Real Time Interrupt (RTI) Module* section in *Peripherals* chapter in the device TRM.

#### **8.4.5.29 Timers**

All timers include specific functions to generate accurate tick interrupts to the operating system.

Each timer can be clocked from several different independent clocks. The selection of clock source is made from registers in the MCU\_CTRL\_MMR0/CTRL\_MMR0.

In the MCU domain the device provides 10 timer pins to be used as MCU Timer Capture inputs or as MCU Timer PWM outputs. In order to provide maximum flexibility, these 10 pins may be used with any of MCU\_TIMER0 through MCU\_TIMER9 instances. System level muxes are used to control the capture source pin for each MCU\_TIMER[9-0] and the MCU\_TIMER[9-0] source for each MCU\_TIMER\_IO[1-0] PWM output.

In the MAIN domain the device provides 8 timer pins to be used as Timer Capture inputs or as Timer PWM outputs. For maximum flexibility, these 8 pins may be used with any of TIMER0 through TIMER19 instances. System level muxes are used to control the capture source pin for each TIMER[19-0] and the TIMER[19-0] source for each TIMER\_IO[7-0] PWM output.

Each odd numbered timer instance from each of the domains may be optionally cascaded with the previous even numbered timer instance from the same domain to form up to a 64-bit timer. For example, TIMER1 may be cascaded to TIMER0, MCU\_TIMER1 may be cascaded to MCU\_TIMER0, etc.

When cascaded, TIMER<sub>i</sub> acts as a 32-bit prescaler to TIMER<sub>i+1</sub>, as well as MCU\_TIMER<sub>n</sub> acts as a 32-bit prescaler to MCU\_TIMER<sub>n+1</sub>. TIMER<sub>i</sub> / MCU\_TIMER<sub>n</sub> must be configured to generate a PWM output edge at the desired rate to increment the TIMER<sub>i+1</sub> / MCU\_TIMER<sub>n+1</sub> counter.

For more information, see *Timers* section in *Peripherals* chapter in the device TRM.

#### 8.4.5.30 UART

The UART is a slave peripheral that utilizes the DMA for data transfer or interrupt polling via host CPU. There are twelve UART modules in the device. All UART modules support IrDA and CIR modes when 48 MHz function clock is used. Each UART can be used for configuration and data exchange with a number of external peripheral devices or interprocessor communication between devices.

For more information, see *Universal Synchronous/Asynchronous Receiver/Transmitter (UART)* section in *Peripherals* chapter in the device TRM.

#### 8.4.5.31 USB

Similar to earlier versions of USB bus, USB 3.0 is a general-purpose cable bus, supporting data exchange between a host device and a wide range of simultaneously accessible peripherals.

The device supports two identical USB subsystems:

- USB3SS0 is SuperSpeed (SS) USB 3.0 Dual-Role-Device (DRD) subsystem with on-chip SS (USB3.0) PHY and HS/FS/LS (1) (USB2.0) PHY
- USB3SS1 is SuperSpeed (SS) USB 3.0 Dual-Role-Device (DRD) subsystem with on-chip SS (USB3.0) PHY and HS/FS/LS (USB2.0) PHY

For more information, see *Universal Serial Bus (USB) Subsystem* section in *Peripherals* chapter in the device TRM.

#### 8.4.5.32 UFS

The Universal Flash Storage (UFS) interface is a standard-based serial interface engine.

There is one UFS module inside the device - UFS0. The UFS module includes one UFS 2.1 host controller (HC) with an integrated M-PHY.

The UFS module complies with the standards as listed in [表 8-1](#).

**表 8-1. UFS Standards**

DOCUMENT	VERSION	DESCRIPTION
JESD220-1A	v1.1	Universal Flash Storage (UFS) Unified Memory Extension
JESD220-2	v1.0	Universal Flash Storage (UFS) Card Extension
JESD220C	v2.1, March 2016	Universal Flash Storage (UFS)



**表 8-1. UFS Standards (continued)**

DOCUMENT	VERSION	DESCRIPTION
JESD223-1B	v1.1A	Universal Flash Storage Host Controller Interface (UFSHCI) Unified Memory Extension
JESD223C	v2.1, March 2016	Universal Flash Storage Host Controller Interface (UFSHCI)
JESD224	March 2013	Universal Flash Storage (UFS) Test
	November, 2001	Federal Information Processing Standards (FIPS) 197 Advanced Encryption Standard (AES)
	v3.1, 2014	MIPI® Alliance Specification for M-PHY
	v1.60, 2013	MIPI Alliance Specification for Unified Protocol (UniProSM)
	Revision 24, August 2010	Small Computer System Interface (SCSI) Block Commands - 3
	Revision 27, October 2010	SCSI Primary Commands - 4

For more information, see *Universal Flash Storage (UFS) Interface* section in *Peripherals* chapter in the device TRM.

## 9 Applications, Implementation, and Layout

注

Information in the following applications sections is not part of the TI component specification, and TI does not warrant its accuracy or completeness. TI's customers are responsible for determining suitability of components for their purposes. Customers should validate and test design implementation to confirm system functionality.

### 9.1 Device Connection and Layout Fundamentals

#### 9.1.1 Power Supply Decoupling and Bulk Capacitors

##### 9.1.1.1 Power Distribution Network Implementation Guidance

The [Sitara Processor Power Distribution Networks: Implementation and Analysis](#) provides guidance for successful implementation of the power distribution network. This includes PCB stackup guidance as well as guidance for optimizing the selection and placement of the decoupling capacitors. TI supports *only* designs that follow the board design guidelines contained in the application report.

#### 9.1.2 External Oscillator

For more information about External Oscillators, see [Clock Specifications](#).

#### 9.1.3 JTAG and EMU

Texas Instruments supports a variety of eXtended Development System (XDS) JTAG controllers with various debug capabilities beyond only JTAG support. A summary of this information is available in the [XDS Target Connection Guide](#).

For more recommendations on EMU routing, see [Emulation and Trace Headers Technical Reference Manual](#)

#### 9.1.4 Reset

The device incorporates four external reset pins (MCU\_PORz, MCU\_RESETz, PORz, and RESET\_REQz) and two reset status pins (MCU\_RESETSTATz and RESETSTATz). These pins can be driven by an external power good circuitry or Power Management IC (PMIC). MCU\_PORz and Main PORz pins should be held active low during the entire power-up phase, and until all power supplies as well as the HFOSC0 clock are stable.

All MCU domain resets act as master resets to the whole device, whereas Main domain resets only reset Main domain (MCU domain is reset isolated from all Main domain resets).

#### 9.1.5 Unused Pins

For more information about Unused Pins, see [Pin Connectivity Requirements](#)

#### 9.1.6 Hardware Design Guide for Jacinto™ 7 Devices

The Hardware Design Guide for Jacinto™ 7 Devices document describes hardware system design considerations for the Jacinto™ 7 family of processors. This design guide is intended to be used as an aid during the development of application hardware.

### 9.2 Peripheral- and Interface-Specific Design Information

#### 9.2.1 LPDDR4 Board Design and Layout Guidelines

The goal of the [Jacinto 7 DDR Board Design and Layout Guidelines](#) is to make the LPDDR4 system implementation straightforward for all designers. Requirements have been distilled down to a set of layout and routing rules that allow designers to successfully implement a robust design for the topologies that TI supports. TI only supports board designs using LPDDR4 memories that follow the guidelines in this document.

#### 9.2.2 OSPI and QSPI Board Design and Layout Guidelines

The following section details the routing guidelines that must be observed when routing the OSPI and QSPI interfaces.

### 9.2.2.1 No Loopback and Internal Pad Loopback

- The MCU\_OSPI[x]\_CLK output signal must be connected to the CLK pin of the flash device
- The signal propagation delay from the MCU\_OSPI[x]\_CLK signal to the flash device must be  $< 450$  ps ( $\sim 7$ cm as stripline or  $\sim 8$ cm as microstrip)
- $50\ \Omega$  PCB routing is recommended along with series terminations, as shown in [Figure 9-1](#)
- Propagation delays and matching:
  - A to B  $< 450$  ps
  - Matching skew:  $< 60$  ps

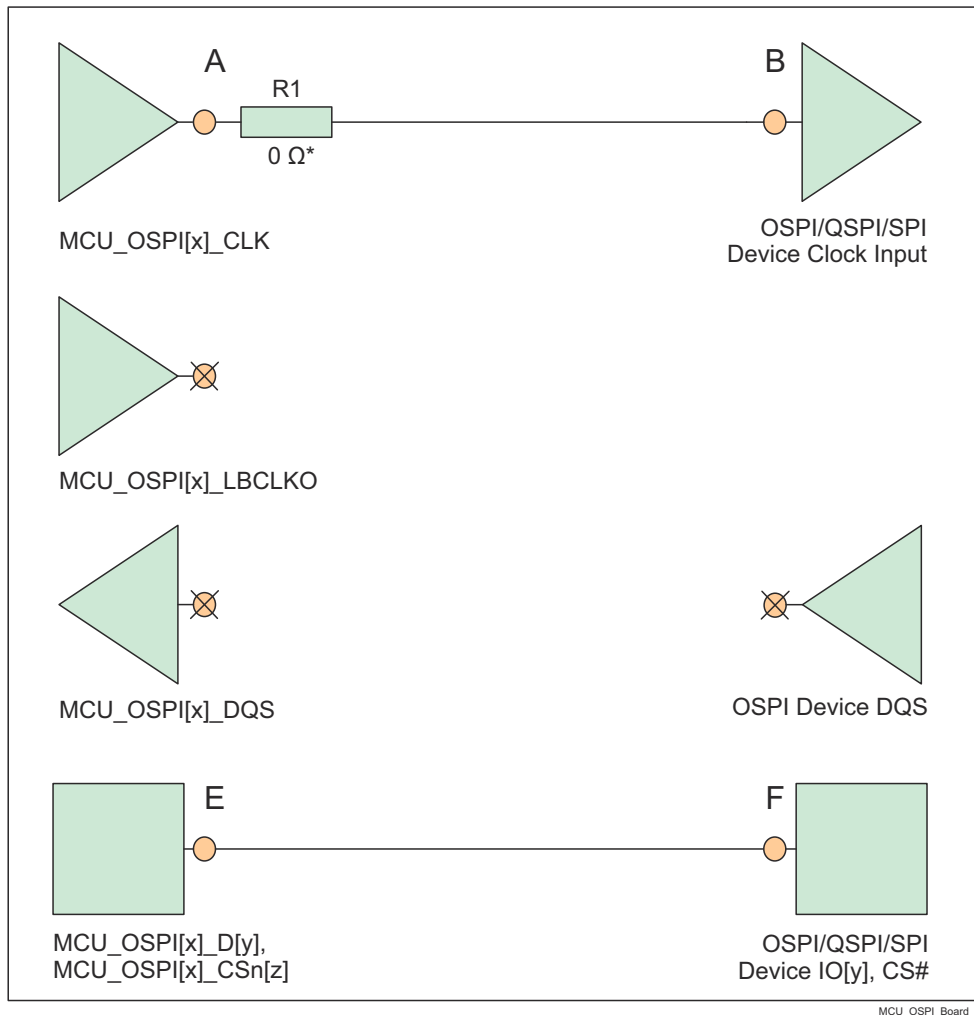

\*  $0\ \Omega$  resistor (R1), located as close as possible to the MCU\_OSPI[x]\_CLK pin, is placeholder for fine tuning, if needed.

**Figure 9-1. OSPI Interface High Level Schematic**

### 9.2.2.2 External Board Loopback

- The MCU\_OSPI[x]\_CLK output signal must be connected to the CLK pin of the flash device
- The MCU\_OSPI[x]\_LBCLKO output signal must be looped back into the MCU\_OSPI[x]\_DQS input
- The signal propagation delay from the MCU\_OSPI[x]\_CLK pin to the flash device CLK input pin (A to B) should be approximately equal to half of the signal propagation delay from the MCU\_OSPI[x]\_LBCLKO pin to the MCU\_OSPI[x]\_DQS pin ((C to D)/2). See the note below.
- The signal propagation delay from the MCU\_OSPI[x]\_CLK pin to the flash device CLK input pin (A to B) must be approximately equal to the signal propagation delay of the control and data signals between the flash device and the SoC device (E to F, or F to E)

- 50 Ω PCB routing is recommended along with series terminations, as shown in [Figure 9-2](#)
- Propagation delays and matching:
  - A to B = E to F = (C to D) / 2
  - Matching skew: < 60 ps

注

The OSPI Board Loopback Hold time requirement (described in [OSPI](#)) is larger than the Hold time provided by a typical flash device. Therefore, the length of MCU\_OSPI[x]\_LBCLKO pin to the MCU\_OSPI[x]\_DQS pin (C to D) can be shortened to compensate.

ADVANCE INFORMATION

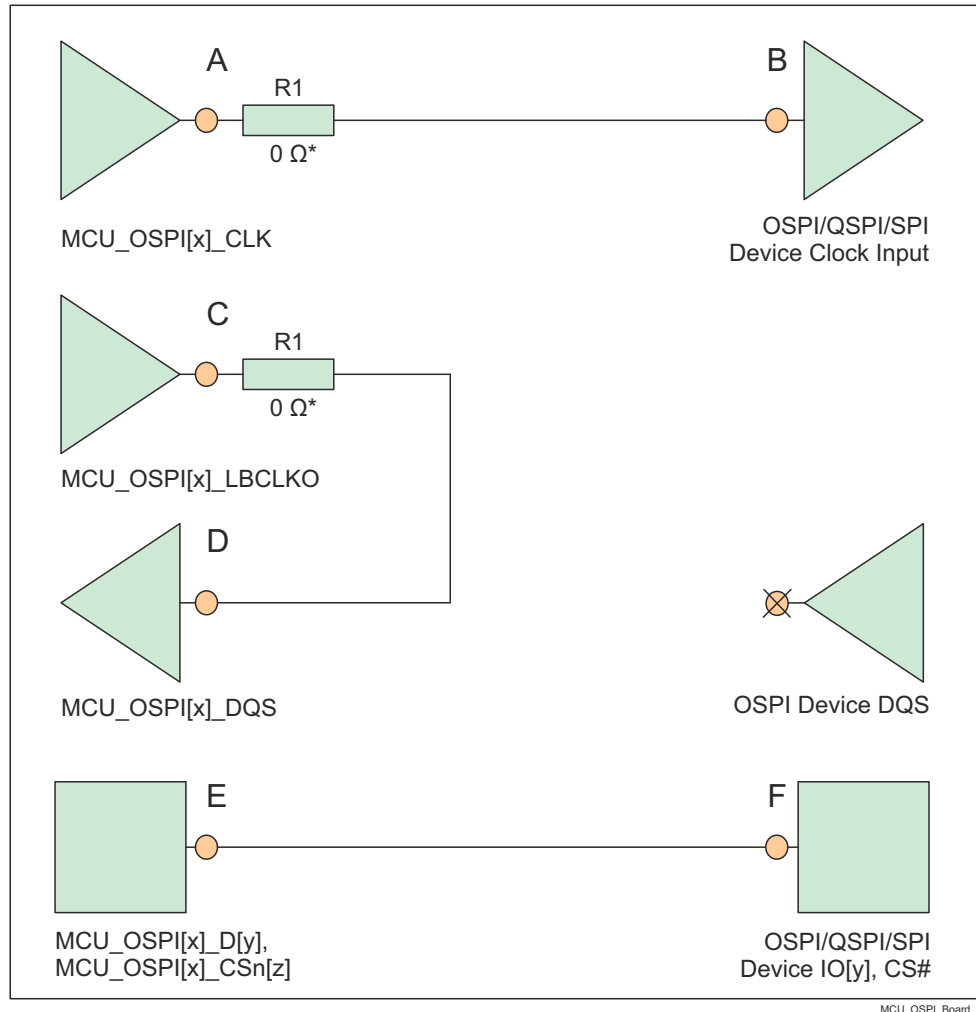

\* 0 Ω resistor (R1), located as close as possible to the MCU\_OSPI[x]\_CLK and MCU\_OSPI[x]\_LBCLKO pins, is a placeholder for fine tuning, if needed.

**Figure 9-2. OSPI Interface High Level Schematic**

**9.2.2.3 DQS (only available in Octal Flash devices)**

- The MCU\_OSPI[x]\_CLK output signal must be connected to the CLK pin of the flash device
- The DQS pin of the flash devices must be connected to MCU\_OSPI[x]\_DQS signal
- The signal propagation delay from the MCU\_OSPI[x]\_CLK pin to the flash device CLK input pin (A to B) should be approximately equal to the signal propagation delay from the MCU\_OSPI[x]\_DQS pin to the DQS output pin (C to D)
- 50 Ω PCB routing is recommended along with series terminations, as shown in [Figure 9-3](#)

- Propagation delays and matching:
  - A to B = C to D
  - Matching skew: < 60 ps

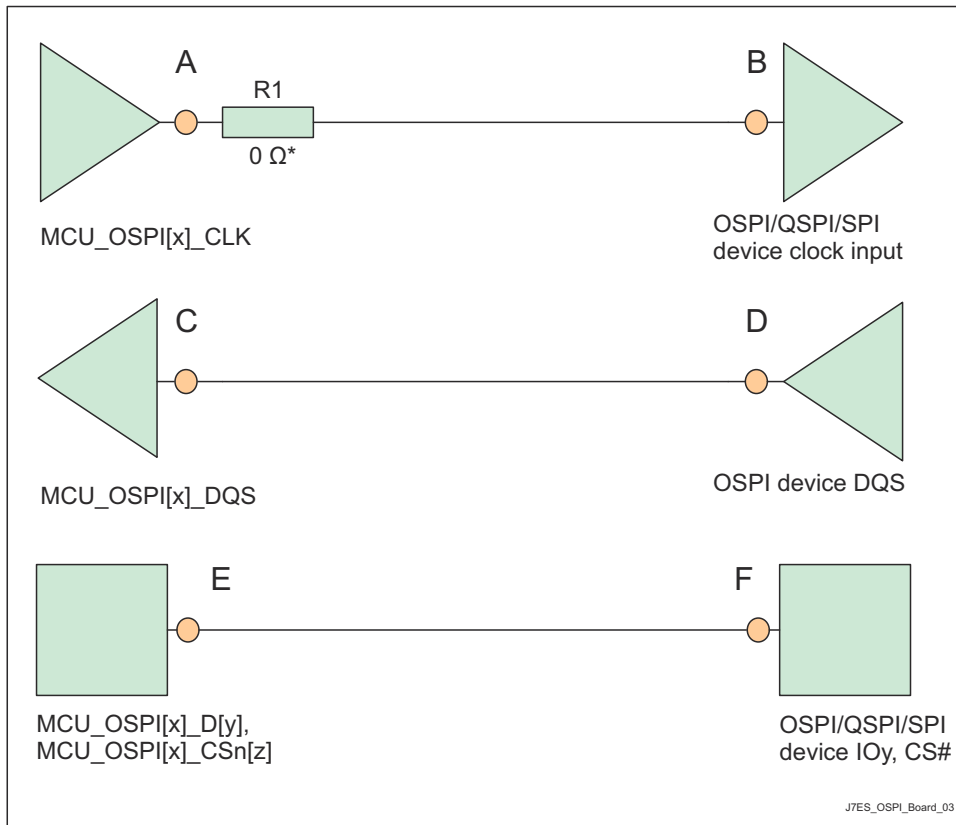

\* 0 Ω resistor (R1), located as close as possible to the MCU\_OSPI[x]\_CLK pin, is a placeholder for fine tuning, if needed.

### 9-3. OSPI Interface High Level Schematic

#### 9.2.3 USB VBUS Design Guidelines

The USB 3.1 specification allows the VBUS voltage to be as high as 5.5 V for normal operation, and as high as 20 V when the Power Delivery addendum is supported. Some automotive applications require a max voltage to be 30 V.

The device requires the VBUS signal voltage be scaled down using an external resistor divider (as shown in the 9-4), which limits the voltage applied to the actual device pin (USB0\_VBUS). The tolerance of these external resistors should be equal to or less than 1%, and the leakage current of zener diode at 5 V should be less than 100 nA.<sup>(1)</sup>

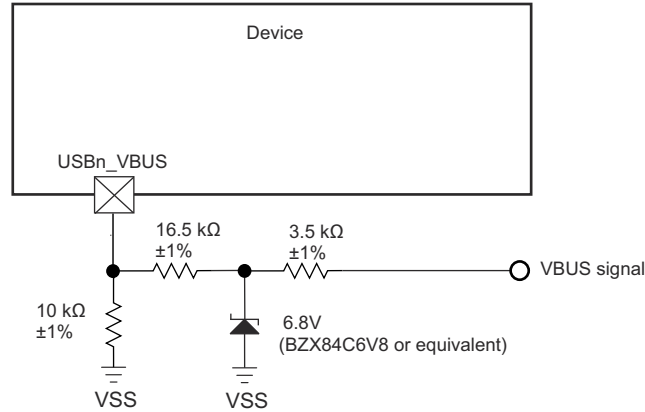

J7ES\_USB\_VBUS\_01

图 9-4. USB VBUS Detect Voltage Divider / Clamp Circuit

The USB0\_VBUS pin can be considered to be fail-safe because the external circuit in 图 9-4 limits the input current to the actual device pin in a case where VBUS is applied while the device is powered off.

### 9.2.4 System Power Supply Monitor Design Guidelines using VMON/POK

The VMON1\_ER\_VSYS pin provides a way to monitor a system power supply. This system power supply is typically a single pre-regulated power source for the entire system. This supply is monitored by comparing the output of an external voltage divider circuit sourced by this supply with an internal voltage reference, with a power fail event being triggered when the voltage applied to VMON1\_ER\_VSYS drops below the internal reference voltage. The actual system power supply voltage trip point is determined by the system designer when selecting component values used to implement the external resistor voltage divider circuit. When designing the resistor divider circuit it is important to understand various factors which contribute to variability in the system power supply monitor trip point. The first thing to consider is the initial accuracy of the VMON1\_ER\_VSYS input threshold which has a nominal value of 0.45 V, with a variation of  $\pm 3\%$ . Precision 1% resistors with similar thermal coefficient are recommended for implementing the resistor voltage divider. This minimizes variability contributed by resistor value tolerances. Input leakage current associated with VMON1\_ER\_VSYS must also be considered since any current flowing into the pin creates a loading error on the voltage divider output. The VMON1\_ER\_VSYS input leakage current may be in the range of 10 nA to 2.5  $\mu$ A when applying 0.45 V.

#### 注

The resistor voltage divider shall be designed such that its output voltage never exceeds the maximum value defined in [Recommended Operating Conditions](#) during normal operating conditions.

图 9-5 presents an example, where the system power supply is nominally 5 V and the maximum trigger threshold is 5 V - 10%, or 4.5 V.

For this example, it is important to understand which variables effect the maximum trigger threshold when selecting resistor values. It is obvious a device which has a VMON1\_ER\_VSYS input threshold of 0.45 V + 3% needs to be considered when trying to design a voltage divider that doesn't trip until the system supply drops 10%. The effect of resistor tolerance and input leakage also needs to be considered, but how these contributions effect the maximum trigger point may not be obvious. When selecting component values which produce a maximum trigger voltage, the system designer must consider a condition where the value of R1 is 1% low and the value of R2 is 1% high combined with a condition where input leakage current for the VMON1\_ER\_VSYS pin is 2.5  $\mu$ A. When implementing a resistor divider where R1 = 4.81 K $\Omega$  and R2 = 40.2 K $\Omega$ , the result is a maximum trigger threshold of 4.523 V.

Once component values have been selected to satisfy the maximum trigger voltage as described above, the system designer can determine the minimum trigger voltage by calculating the applied voltage that produces an output voltage of 0.45 V - 3% when the value of R1 is 1% high and the value of R2 is 1% low, and the input

leakage current is 10 nA, or zero. Using an input leakage of zero with the resistor values given above, the result is a minimum trigger threshold of 4.008 V.

This example demonstrates a system power supply voltage trip point that ranges from 4.008 V to 4.523 V. Approximately 250 mV of this range is introduced by VMON1\_ER\_VSYS input threshold accuracy of  $\pm 3\%$ , approximately 150 mV of this range is introduced by resistor tolerance of  $\pm 1\%$ , and approximately 100 mV of this range is introduced by loading error when VMON1\_ER\_VSYS input leakage current is 2.5  $\mu\text{A}$ .

The resistor values selected in this example produces approximately 100  $\mu\text{A}$  of bias current through the resistor divider when the system supply is 4.5 V. The 100 mV of loading error mentioned above could be reduced to about 10 mV by increasing the bias current through the resistor divider to approximately 1 mA. So resistor divider bias current vs loading error is something the system designer needs to consider when selecting component values.

The system designer should also consider implementing a noise filter on the voltage divider output since VMON1\_ER\_VSYS has minimum hysteresis and a high-bandwidth response to transients. This could be done by installing a capacitor across R1 as shown in [Figure 9-5](#). However, the system designer must determine the response time of this filter based on system supply noise and expected response to transient events.

[Figure 9-5](#) presents an example, when the system power supply voltage is nominally 5 V and the desired trigger threshold is -10% or 4.5 V.

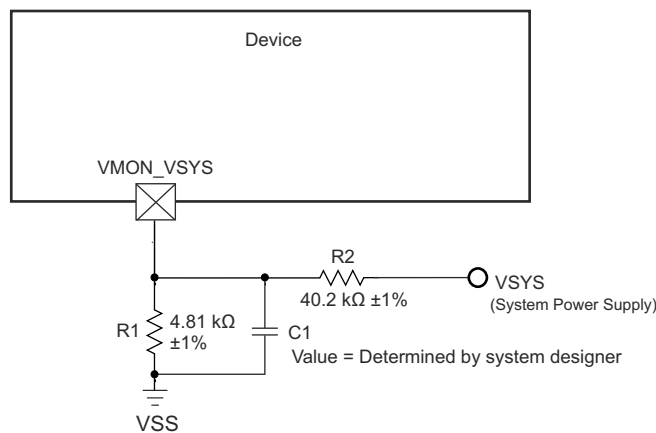

SPRSP56\_VMON\_ER\_MON\_01

**Figure 9-5. System Supply Monitor Voltage Divider Circuit**

The **VMON2\_IR\_VCPU** pin provides a way to monitor VDD\_CPU power supply. Must be externally connected as close as possible to VDD\_CPU pin on the board. SoCs that have a **VMON6\_IR\_VEXT0P8** can optionally monitor other domains such as VDD\_CORE or VDD\_MCU. Similarly, those signals should be as close as possible to VDD\_CORE or VDD\_MCU pin on the board.

The **VMON3\_IR\_VEXT1P8** and **VMON4\_IR\_VEXT1P8** pins provide a way to monitor an external 1.8-V power supply. The **VMON5\_IR\_VEXT3P3** pin provides a way to monitor an external 3.3-V power supply. An internal resistor divider with software control is implemented inside the SoC. Software can program the internal resistor divider to create appropriate under voltage and over voltage interrupts. These pins should not be sourced from an external resistor divider. If the monitored voltage requires adjustment, be sure to buffer the divided voltage prior connecting to monitor pin.

### 9.2.5 High Speed Differential Signal Routing Guidance

The [High Speed Interface Layout Guidelines](#) provides guidance for successful routing of the high speed differential signals. This includes PCB stackup and materials guidance as well as routing skew, length and spacing limits. TI supports *only* designs that follow the board design guidelines contained in the application report.

### 9.2.6 Thermal Solution Guidance

The [Thermal Design Guide for DSP and ARM Application Processors](#) provides guidance for successful implementation of a thermal solution for system designs containing this device. This document provides background information on common terms and methods related to thermal solutions. TI only supports designs that follow system design guidelines contained in the application report.



## 10 Device and Documentation Support

TI offers an extensive line of development tools. Tools and software to evaluate the performance of the device, generate code, and develop solutions are listed below.

### 10.1 Device Nomenclature

To designate the stages in the product development cycle, TI assigns prefixes to the part numbers of all microprocessors (MPUs) and support tools. Each device has one of three prefixes: X, P, or null (no prefix) (for example, TDA4VM). Texas Instruments recommends two of three possible prefix designators for its support tools: TMDX and TMDS. These prefixes represent evolutionary stages of product development from engineering prototypes (TMDX) through fully qualified production devices and tools (TMDS).

Device development evolutionary flow:

- X** Experimental device that is not necessarily representative of the final device's electrical specifications and may not use production assembly flow.
- P** Prototype device that is not necessarily the final silicon die and may not necessarily meet final electrical specifications.
- null** Production version of the silicon die that is fully qualified.

Support tool development evolutionary flow:

- TMDX** Development-support product that has not yet completed Texas Instruments internal qualification testing.
- TMDS** Fully-qualified development-support product.

X and P devices and TMDX development-support tools are shipped against the following disclaimer:

"Developmental product is intended for internal evaluation purposes."

Production devices and TMDS development-support tools have been characterized fully, and the quality and reliability of the device have been demonstrated fully. TI's standard warranty applies.

Predictions show that prototype devices (X or P) have a greater failure rate than the standard production devices. Texas Instruments recommends that these devices not be used in any production system because their expected end-use failure rate still is undefined. Only qualified production devices are to be used.

For orderable part numbers of TDA4VM devices in the ALF package type, see the Package Option Addendum of this document, the TI website ([ti.com](http://ti.com)), or contact your TI sales representative.

### 10.1.1 Standard Package Symbolization

注

Some devices may have a cosmetic circular marking visible on the top of the device package which results from the production test process. In addition, some devices may also show a color variation in the package substrate which results from the substrate manufacturer. These differences are cosmetic only with no reliability impact.

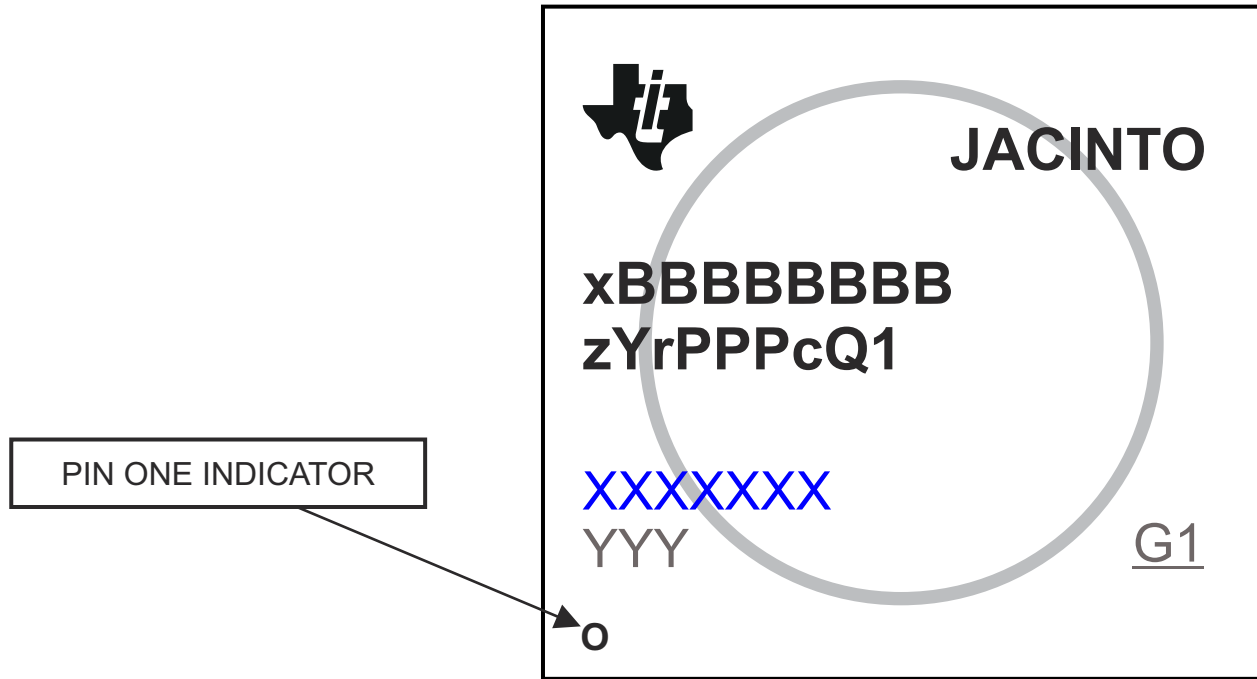

☒ 10-1. Printed Device Reference

ADVANCE INFORMATION

## 10.1.2 Device Naming Convention

表 10-1. Nomenclature Description

FIELD PARAMETER	FIELD DESCRIPTION	VALUES		DESCRIPTION
		MARKING	ORDERABLE	
x	Device evolution stage <sup>(1)</sup>	X		Prototype
		P		Preproduction (production test flow, no reliability data)
		BLANK		Production
BBBBBBB <sup>(2)</sup>	Base production part number	J784S4 <sup>(2)</sup>		Preproduction superset device
		TDA4VH88		See 表 5-1, <i>Device Comparison</i>
		TDA4AH88		
		TDA4VP88		
		TDA4AP88		
z	Device Speed	T		See 表 7-1, <i>Speed Grade Maximum Frequency</i> .
		OTHER		Alternate speed grade
Y	Device type	G		General purpose
		C		General purpose, R5F Lockstep capable
		0		High Security <sup>(3)</sup> capable
		5		High Security <sup>(3)</sup> capable, R5F Lockstep capable
		D		High Security <sup>(3)</sup> capable, R5F Lockstep capable, Customer Dev Keys. Only available on preproduction J784S4 devices.
r	Device revision	A or BLANK		SR 1.0
PPP	Package designator	ALY		ALY FCBGA-N1414 (31 mm x 31 mm) Package
c	Carrier designator	N/A	BLANK	Tray
		N/A	R	Tape and Reel
Q1	Automotive Designator	BLANK		Not automotive qualified. Supports T <sub>J</sub> = –40°C to 105°C
		Q1		Meet AEC-Q100 qualification requirements, with exceptions as specified in this document (data sheet). Supports T <sub>J</sub> = –40°C to 125°C
XXXXXXX	Lot Trace Code	As Marked	N/A	Lot Trace Code (LTC)
YYY	Production Code	As Marked	N/A	Production Code, for TI use only
ZZZ	Production Code	As Marked	N/A	Production Code, for TI use only
O	Pin One	As Marked	N/A	Pin one designator
G1	ECAT	As Marked	N/A	ECAT—Green package designator

- (1) To designate the stages in the product development cycle, TI assigns prefixes to the part numbers. These prefixes represent evolutionary stages of product development from engineering prototypes through fully qualified production devices. Prototype devices are shipped against the following disclaimer:  
"This product is still in development and is intended for internal evaluation purposes."  
Notwithstanding any provision to the contrary, TI makes no warranty expressed, implied, or statutory, including any implied warranty of merchantability of fitness for a specific purpose, of this device.
- (2) J784S4 is the base part number for the preproduction superset device. Software should constrain the features used to match the intended production device.
- (3) For HS device support, TI recommends the 0, 5, or D device types.

注

BLANK in the symbol or part number is collapsed so there are no gaps between characters.

## 10.2 Tools and Software

The following products support development for TDA4VH/AH/VP-Q1 platforms:

### Development Tools

**Code Composer Studio™ Integrated Development Environment** Code Composer Studio (CCS) Integrated Development Environment (IDE) is a development environment that supports TI's Microcontroller and Embedded Processors portfolio. Code Composer Studio comprises a suite of tools used to develop and debug embedded applications. It includes an optimizing C/C++ compiler, source code editor, project build environment, debugger, profiler, and many other features. The intuitive IDE provides a single user interface taking you through each step of the application development flow. Familiar tools and interfaces allow users to get started faster than ever before. Code Composer Studio combines the advantages of the Eclipse software framework with advanced embedded debug capabilities from TI resulting in a compelling feature-rich development environment for embedded developers.

**Pin mux tool** The Pin MUX Utility is a software tool which provides a Graphical User Interface for configuring pin multiplexing settings, resolving conflicts and specifying I/O cell characteristics for TI MPUs. Results are output as C header/code files that can be imported into software development kits (SDKs) or used to configure customer's custom software. Version 4 of the Pin Mux utility adds the capability of automatically selecting a mux configuration that satisfies the entered requirements.

For a complete listing of development-support tools for the processor platform, visit the Texas Instruments website at [ti.com](http://ti.com). For information on pricing and availability, contact the nearest TI field sales office or authorized distributor.

### 10.3 サポート・リソース

**TI E2E™ サポート・フォーラム**は、エンジニアが検証済みの回答と設計に関するヒントをエキスパートから迅速かつ直接得ることができる場所です。既存の回答を検索したり、独自の質問をしたりすることで、設計に必要な支援を迅速に得ることができます。

リンクされているコンテンツは、該当する貢献者により、現状のまま提供されるものです。これらは TI の仕様を構成するものではなく、必ずしも TI の見解を反映したものではありません。TI の [使用条件](#)を参照してください。

### 10.4 Trademarks

eMMC™ is a trademark of MultiMediaCard Association.

Jacinto™, Code Composer Studio™, and TI E2E™ are trademarks of Texas Instruments.

CoreSight™ is a trademark of Arm Limited (or its subsidiaries) in the US and/or elsewhere.

Arm® and Cortex® are registered trademarks of Arm Limited (or its subsidiaries) in the US and/or elsewhere.

PCI-Express® is a registered trademark of PCI-SIG.

Secure Digital® is a registered trademark of SD Card Association.

MIPI® is a registered trademark of MIPI Alliance, Inc.

すべての商標は、それぞれの所有者に帰属します。

### 10.5 静電気放電に関する注意事項



この IC は、ESD によって破損する可能性があります。テキサス・インスツルメンツは、IC を取り扱う際には常に適切な注意を払うことを推奨します。正しい取り扱いおよび設置手順に従わない場合、デバイスを破損するおそれがあります。

ESD による破損は、わずかな性能低下からデバイスの完全な故障まで多岐にわたります。精密な IC の場合、パラメータがわずかに変化するだけで公表されている仕様から外れる可能性があるため、破損が発生しやすくなっています。

### 10.6 用語集

[テキサス・インスツルメンツ用語集](#)

この用語集には、用語や略語の一覧および定義が記載されています。

## 11 Mechanical, Packaging, and Orderable Information

### 11.1 Packaging Information

The following pages include mechanical, packaging, and orderable information. This information is the most current data available for the designated devices. This data is subject to change without notice and revision of this document. For browser-based versions of this data sheet, refer to the left-hand navigation.

**PACKAGING INFORMATION**

Orderable Device	Status (1)	Package Type	Package Drawing	Pins	Package Qty	Eco Plan (2)	Lead finish/ Ball material (6)	MSL Peak Temp (3)	Op Temp (°C)	Device Marking (4/5)	Samples
TDA4AH88TGAALYRQ1	ACTIVE	FCBGA	ALY	1414	200	RoHS & Green	Call TI	Level-3-250C-168 HR	-40 to 125	TDA4AH88 TGAALYQ1 259	Samples
TDA4AP88TGAALYRQ1	ACTIVE	FCBGA	ALY	1414	200	RoHS & Green	Call TI	Level-3-250C-168 HR	-40 to 125	TDA4AP88 TGAALYQ1 259	Samples
TDA4VH88TGAALYRQ1	ACTIVE	FCBGA	ALY	1414	200	RoHS & Green	Call TI	Level-3-250C-168 HR	-40 to 125	TDA4VH88 TGAALYQ1 259	Samples
TDA4VP88TGAALYRQ1	ACTIVE	FCBGA	ALY	1414	200	RoHS & Green	Call TI	Level-3-250C-168 HR	-40 to 125	TDA4VP88 TGAALYQ1 259	Samples
XTDA4AHXXXGAALY	ACTIVE	FCBGA	ALY	1414	1	TBD	Call TI	Call TI	-40 to 125		Samples

(1) The marketing status values are defined as follows:

**ACTIVE:** Product device recommended for new designs.

**LIFEBUY:** TI has announced that the device will be discontinued, and a lifetime-buy period is in effect.

**NRND:** Not recommended for new designs. Device is in production to support existing customers, but TI does not recommend using this part in a new design.

**PREVIEW:** Device has been announced but is not in production. Samples may or may not be available.

**OBSELETE:** TI has discontinued the production of the device.

(2) **RoHS:** TI defines "RoHS" to mean semiconductor products that are compliant with the current EU RoHS requirements for all 10 RoHS substances, including the requirement that RoHS substance do not exceed 0.1% by weight in homogeneous materials. Where designed to be soldered at high temperatures, "RoHS" products are suitable for use in specified lead-free processes. TI may reference these types of products as "Pb-Free".

**RoHS Exempt:** TI defines "RoHS Exempt" to mean products that contain lead but are compliant with EU RoHS pursuant to a specific EU RoHS exemption.

**Green:** TI defines "Green" to mean the content of Chlorine (Cl) and Bromine (Br) based flame retardants meet JS709B low halogen requirements of <=1000ppm threshold. Antimony trioxide based flame retardants must also meet the <=1000ppm threshold requirement.

(3) MSL, Peak Temp. - The Moisture Sensitivity Level rating according to the JEDEC industry standard classifications, and peak solder temperature.

(4) There may be additional marking, which relates to the logo, the lot trace code information, or the environmental category on the device.

(5) Multiple Device Markings will be inside parentheses. Only one Device Marking contained in parentheses and separated by a "~" will appear on a device. If a line is indented then it is a continuation of the previous line and the two combined represent the entire Device Marking for that device.

<sup>(6)</sup> Lead finish/Ball material - Orderable Devices may have multiple material finish options. Finish options are separated by a vertical ruled line. Lead finish/Ball material values may wrap to two lines if the finish value exceeds the maximum column width.

**Important Information and Disclaimer:**The information provided on this page represents TI's knowledge and belief as of the date that it is provided. TI bases its knowledge and belief on information provided by third parties, and makes no representation or warranty as to the accuracy of such information. Efforts are underway to better integrate information from third parties. TI has taken and continues to take reasonable steps to provide representative and accurate information but may not have conducted destructive testing or chemical analysis on incoming materials and chemicals. TI and TI suppliers consider certain information to be proprietary, and thus CAS numbers and other limited information may not be available for release.

In no event shall TI's liability arising out of such information exceed the total purchase price of the TI part(s) at issue in this document sold by TI to Customer on an annual basis.

**TAPE AND REEL INFORMATION**

**QUADRANT ASSIGNMENTS FOR PIN 1 ORIENTATION IN TAPE**

\*All dimensions are nominal

Device	Package Type	Package Drawing	Pins	SPQ	Reel Diameter (mm)	Reel Width W1 (mm)	A0 (mm)	B0 (mm)	K0 (mm)	P1 (mm)	W (mm)	Pin1 Quadrant
TDA4AH88TGAALYRQ1	FCBGA	ALY	1414	200	330.0	44.4	31.4	31.4	4.0	36.0	16.0	Q1
TDA4AP88TGAALYRQ1	FCBGA	ALY	1414	200	330.0	44.4	31.4	31.4	4.0	36.0	16.0	Q1
TDA4VH88TGAALYRQ1	FCBGA	ALY	1414	200	330.0	44.4	31.4	31.4	4.0	36.0	16.0	Q1
TDA4VP88TGAALYRQ1	FCBGA	ALY	1414	200	330.0	44.4	31.4	31.4	4.0	36.0	16.0	Q1



**TAPE AND REEL BOX DIMENSIONS**

\*All dimensions are nominal

Device	Package Type	Package Drawing	Pins	SPQ	Length (mm)	Width (mm)	Height (mm)
TDA4AH88TGAALYRQ1	FCBGA	ALY	1414	200	336.6	336.6	53.2
TDA4AP88TGAALYRQ1	FCBGA	ALY	1414	200	336.6	336.6	53.2
TDA4VH88TGAALYRQ1	FCBGA	ALY	1414	200	336.6	336.6	53.2
TDA4VP88TGAALYRQ1	FCBGA	ALY	1414	200	336.6	336.6	53.2

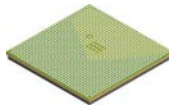

# PACKAGE OUTLINE

## ALY1414A

### FCBGA - 3.341 mm max height

BALL GRID ARRAY

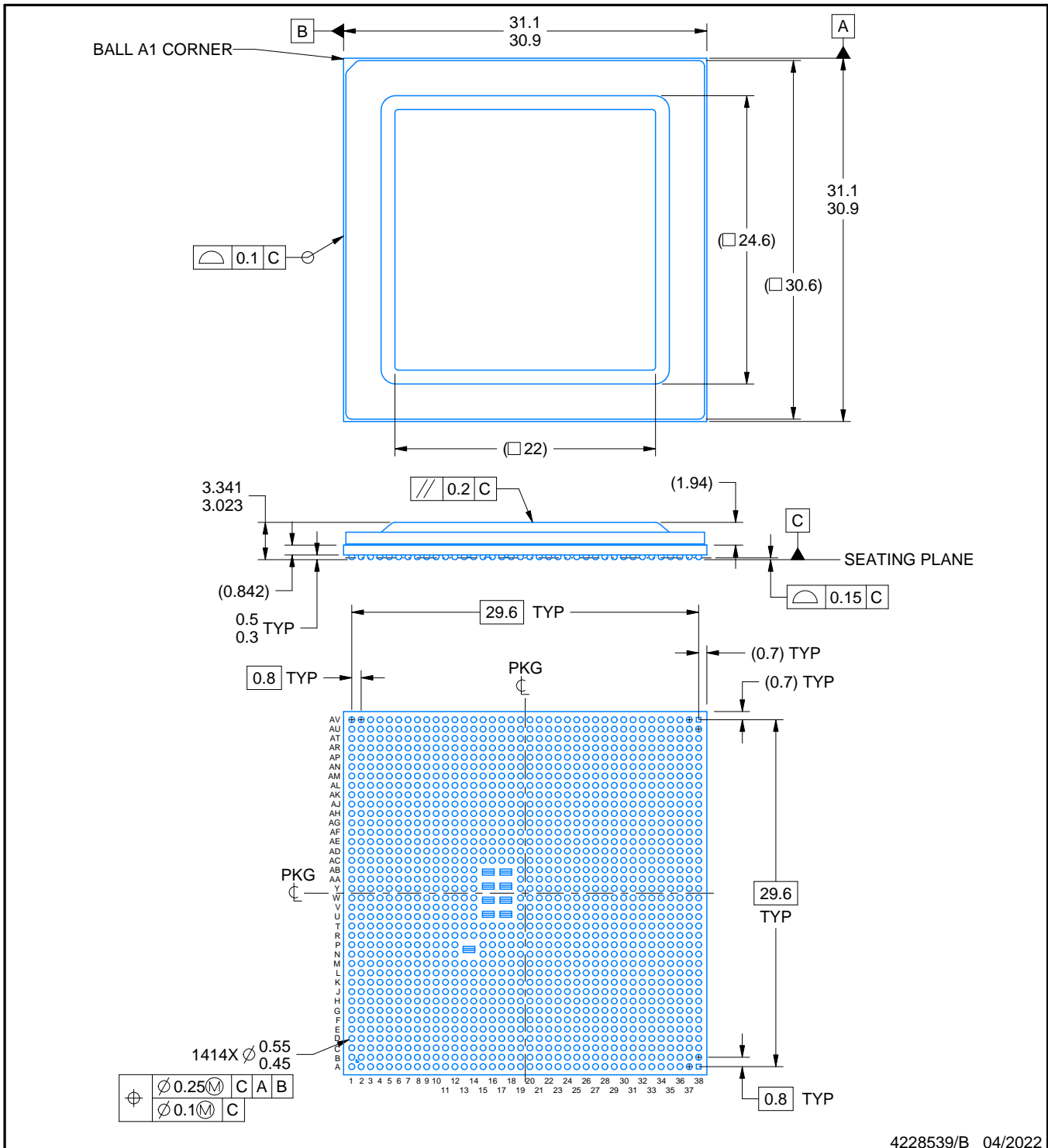

4228539/B 04/2022

# EXAMPLE BOARD LAYOUT

ALY1414A

FCBGA - 3.341 mm max height

BALL GRID ARRAY

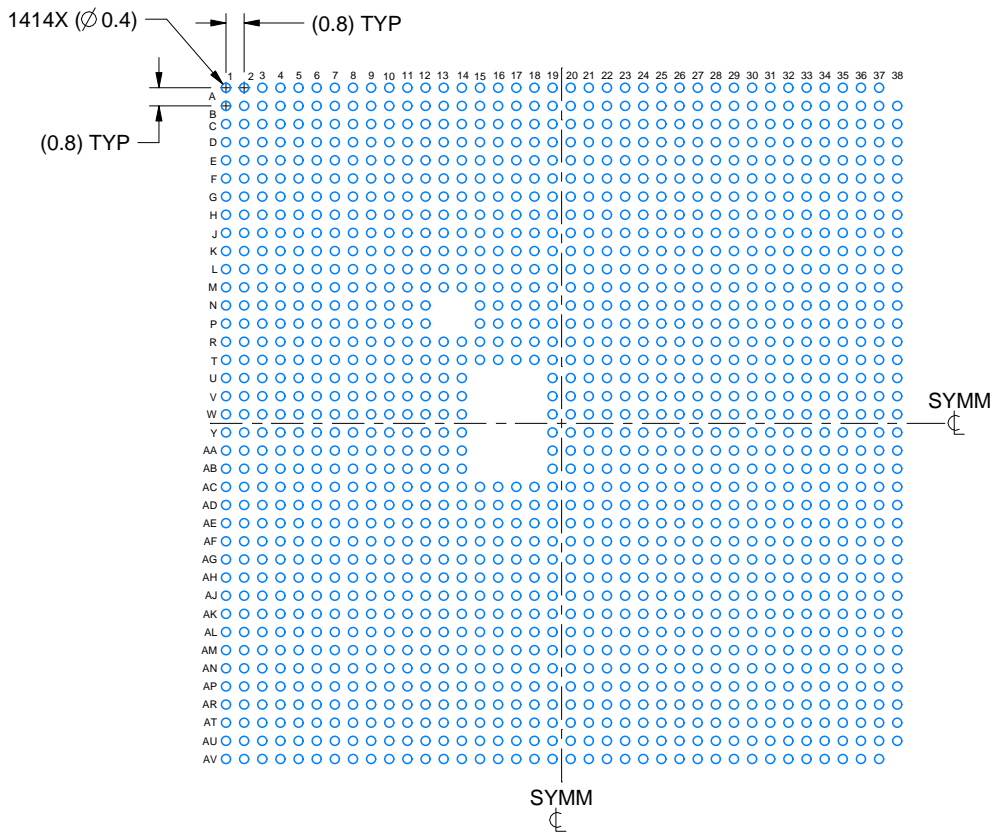

LAND PATTERN EXAMPLE  
EXPOSED METAL SHOWN  
SCALE:3X

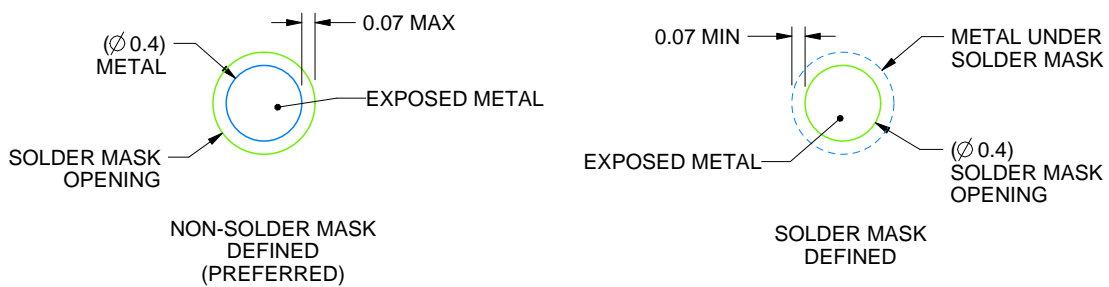

SOLDER MASK DETAILS  
NOT TO SCALE

4228539/B 04/2022

NOTES: (continued)

- Final dimensions may vary due to manufacturing tolerance considerations and also routing constraints. For more information, see Texas Instruments literature number SPRU811 ([www.ti.com/lit/spru811](http://www.ti.com/lit/spru811)).

# EXAMPLE STENCIL DESIGN

## ALY1414A

### FCBGA - 3.341 mm max height

BALL GRID ARRAY

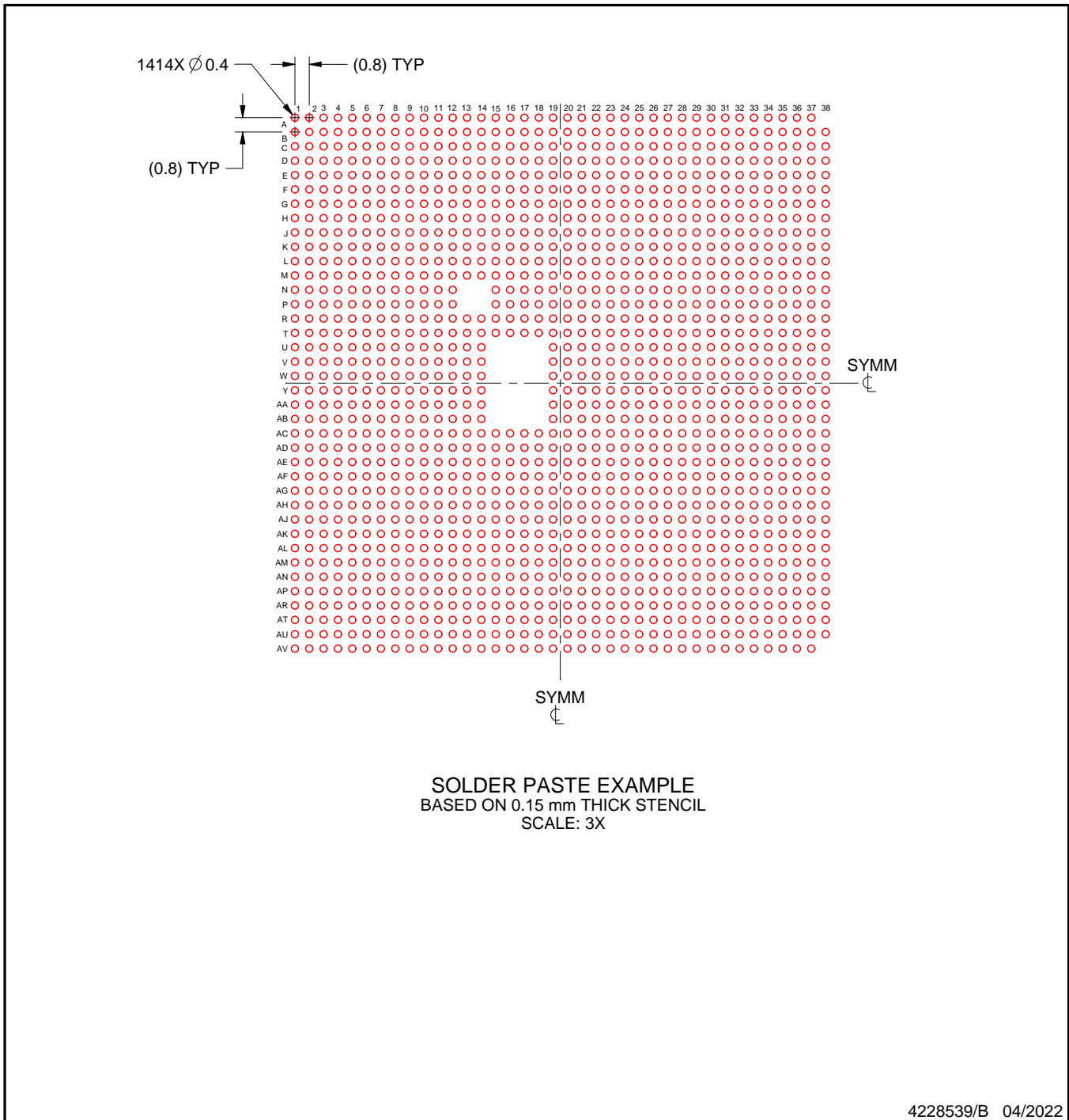

NOTES: (continued)

4. Laser cutting apertures with trapezoidal walls and rounded corners may offer better paste release.

## 重要なお知らせと免責事項

テキサス・インスツルメンツは、技術データと信頼性データ(データシートを含みます)、設計リソース(リファレンス デザインを含みます)、アプリケーションや設計に関する各種アドバイス、Web ツール、安全性情報、その他のリソースを、欠陥が存在する可能性のある「現状のまま」提供しており、商品性および特定目的に対する適合性の黙示保証、第三者の知的財産権の非侵害保証を含むいかなる保証も、明示的または黙示的にかかわらず拒否します。

これらのリソースは、テキサス・インスツルメンツ製品を使用する設計の経験を積んだ開発者への提供を意図したものです。(1) お客様のアプリケーションに適したテキサス・インスツルメンツ製品の選定、(2) お客様のアプリケーションの設計、検証、試験、(3) お客様のアプリケーションに該当する各種規格や、その他のあらゆる安全性、セキュリティ、規制、または他の要件への確実な適合に関する責任を、お客様のみが単独で負うものとし、ます。

上記の各種リソースは、予告なく変更される可能性があります。これらのリソースは、リソースで説明されているテキサス・インスツルメンツ製品を使用するアプリケーションの開発の目的でのみ、テキサス・インスツルメンツはその使用をお客様に許諾します。これらのリソースに関して、他の目的で複製することや掲載することは禁止されています。テキサス・インスツルメンツや第三者の知的財産権のライセンスが付与されている訳ではありません。お客様は、これらのリソースを自身で使用した結果発生するあらゆる申し立て、損害、費用、損失、責任について、テキサス・インスツルメンツおよびその代理人を完全に補償するものとし、テキサス・インスツルメンツは一切の責任を拒否します。

テキサス・インスツルメンツの製品は、[テキサス・インスツルメンツの販売条件](#)、または [ti.com](https://www.ti.com) やかかるテキサス・インスツルメンツ製品の関連資料などのいずれかを通じて提供する適用可能な条項の下で提供されています。テキサス・インスツルメンツがこれらのリソースを提供することは、適用されるテキサス・インスツルメンツの保証または他の保証の放棄の拡大や変更を意味するものではありません。

お客様がいかなる追加条項または代替条項を提案した場合でも、テキサス・インスツルメンツはそれらに異議を唱え、拒否します。

郵送先住所：Texas Instruments, Post Office Box 655303, Dallas, Texas 75265  
Copyright © 2025, Texas Instruments Incorporated