

TLIN2024A-Q1 ドミナント状態タイムアウト機能搭載、クワッド LIN (Local Interconnect Network) トランシーバ

1 特長

- 車載アプリケーション用に AEC-Q100 (グレード 1) 認証済み
- LIN2.0、LIN2.1、LIN2.2、LIN2.2A、および ISO/DIS 17987-4 電氣的物理層 (EPL) 仕様に準拠
- SAE J2602-1 に準拠した車載用途向け LIN ネットワーク
- 機能安全対応
 - 機能安全システム的设计に役立つ資料を利用可能
- 12V および 24V バッテリ・アプリケーションをサポート
- 最高 20kbps の LIN 送信データ・レート
- 最高 100kbps の LIN 受信データ・レート
- 広い動作電源電圧範囲: 4V~48V
- スリープ・モード: 超低消費電流で、以下に示すウェイクアップ・イベントに対応
 - LIN バス
 - EN によるローカル・ウェイクアップ
- 45kΩ の LIN プルアップ抵抗を内蔵
- 電源オン/オフ時の LIN バスと RXD 出力のグリッチを防止
- 保護機能:
 - LIN バスの障害耐性: ±60V
 - V_{SUP} の低電圧保護
 - TXD ドミナント・タイムアウト保護 (DTO)
 - サーマル・シャットダウン保護機能
 - 電源なしノードまたはグランド切断に対するシステム・レベルのフェイルセーフ
- 自動光学検査 (AOI) 性能を向上させた 3.5mm × 5.5mm VQFN パッケージ

2 アプリケーション

- ボディ・エレクトロニクスおよび照明
- ハイブリッド電気自動車およびパワー・トレイン・システム
- インフォテインメントとクラスタ
- 家電製品

3 概要

TLIN2024A-Q1 デバイスは、クワッド・ローカル相互接続ネットワーク (LIN) の物理層トランシーバで、ウェイクアップおよび保護機能が内蔵され、LIN2.0、LIN2.1、LIN2.2、LIN2.2A、および ISO/DIS 17987-4 標準に準拠しています。LIN は単線式の双方向バスで、データ・レートが 20kbps までの低速の車内用ネットワークで一般に使用されます。TLIN2024A-Q1 は、幅広い動作電圧と追加のバス・フォルト保護機能により 12V および 24V アプリケーションをサポートするように設計されています。このデバイスには、2 つの独立したデュアル LIN トランシーバ・ブロックがあります。V_{SUP1/2} が、別々のデュアル・トランシーバ・ブロックを制御します。

TLIN2024A-Q1 レシーバは、高速インライン・プログラミング用に最大 100kbps のデータ・レートをサポートしています。このデバイスは、TXD 入力の LIN プロトコルのデータ・ストリームを、電流が制限された波形整形ドライバを使用して LIN バス信号に変換し、電磁気放射 (EME) を低減します。このレシーバは、データ・ストリームをロジック・レベル信号に変換し、オープン・ドレインの RXD ピンを経由してマイクロプロセッサに送信します。LIN バスや EN ピンによってウェイクアップできるスリープ・モードを使用すれば、非常に低い消費電流を実現できます。

製品情報

| 部品番号 | パッケージ ⁽¹⁾ | 本体サイズ (公称) |
|--------------|----------------------|-----------------|
| TLIN2024A-Q1 | VQFN (24) | 3.50mm × 5.50mm |

- (1) 利用可能なパッケージについては、このデータシートの末尾にある注文情報を参照してください。

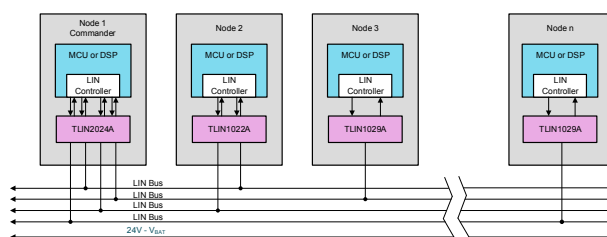

概略回路図



Table of Contents

| | | | |
|--|----|--|----|
| 1 特長 | 1 | 9.1 Overview..... | 19 |
| 2 アプリケーション | 1 | 9.2 Functional Block Diagram..... | 20 |
| 3 概要 | 1 | 9.3 Feature Description..... | 20 |
| 4 Revision History | 2 | 9.4 Device Functional Modes..... | 24 |
| 5 概要 (続き) | 2 | 10 Application and Implementation Disclaimer | 26 |
| 6 Pin Configuration and Functions | 3 | 10.1 Application Information..... | 26 |
| 7 Specifications | 4 | 10.2 Typical Application..... | 26 |
| 7.1 Absolute Maximum Ratings..... | 4 | 10.3 Power Supply Recommendations..... | 28 |
| 7.2 ESD Ratings..... | 4 | 10.4 Layout..... | 28 |
| 7.3 ESD Ratings - IEC..... | 4 | 11 Device and Documentation Support | 30 |
| 7.4 Thermal Information..... | 5 | 11.1 Documentation Support..... | 30 |
| 7.5 Recommended Operating Conditions..... | 5 | 11.2 Receiving Notification of Documentation Updates.. | 30 |
| 7.6 Electrical Characteristics..... | 6 | 11.3 サポート・リソース..... | 30 |
| 7.7 Duty Cycle Characteristics..... | 8 | 11.4 Trademarks..... | 30 |
| 7.8 Switching Characteristics..... | 10 | 11.5 Glossary..... | 30 |
| 8 Parameter Measurement Information | 11 | 12 Mechanical, Packaging, and Orderable Information | 31 |
| 9 Detailed Description | 19 | | |

4 Revision History

資料番号末尾の英字は改訂を表しています。その改訂履歴は英語版に準じています。

| DATE | REVISION | NOTES |
|-----------|----------|-----------------|
| June 2022 | * | Initial release |

5 概要 (続き)

TLIN2024A-Q1 には LIN レスポンダ・ノード・アプリケーション用の抵抗、ESD 保護、フォルト保護が内蔵されているため、アプリケーションの外付け部品数を減らせます。このデバイスでは、グラウンドのシフトまたは電源電圧の切断が発生しても、電流が LIN 経路で電源入力に逆流することはありません。本デバイスは、低電圧検出、サーマル・シャットダウン保護、グラウンド喪失保護機能も内蔵しています。

6 Pin Configuration and Functions

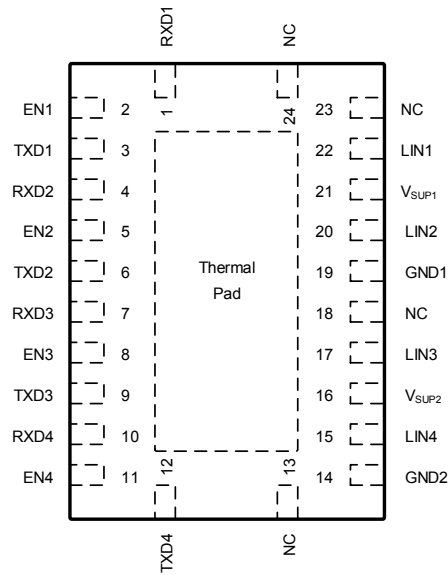

**6-1. RGY Package, 24-Pin RGY (VQFN)
(Top View)**

表 6-1. Pin Functions

| PIN | | TYPE ⁽¹⁾ | DESCRIPTION |
|-------------------|----------------|---------------------|---|
| NAME | NO. | | |
| RXD1 | 1 | O | Channel 1 RXD Output (open-drain) interface reporting state of LIN1 bus voltage |
| EN1 | 2 | I | Channel 1 Enable Input |
| TXD1 | 3 | I | Channel 1 TXD input interface to control state of LIN output |
| RXD2 | 4 | O | Channel 2 RXD Output (open-drain) interface reporting state of LIN2 bus voltage |
| EN2 | 5 | I | Channel 2 Enable Input |
| TXD2 | 6 | I | Channel 2 TXD input interface to control state of LIN2 output |
| RXD3 | 7 | O | Channel 3 RXD Output (open-drain) interface reporting state of LIN3 bus voltage |
| EN3 | 8 | I | Channel 3 Enable Input |
| TXD3 | 9 | I | Channel 3 TXD input interface to control state of LIN3 output |
| RXD4 | 10 | O | Channel 4 RXD Output (open-drain) interface reporting state of LIN4 bus voltage |
| EN4 | 11 | I | Channel 4 Enable Input |
| TXD4 | 12 | I | Channel 4 TXD input interface to control state of LIN4 output |
| GND2 | 14 | G | Ground pin for Channels 3 and 4 |
| LIN4 | 15 | I/O | Channel 4 LIN Bus single-wire transmitter and receiver |
| V _{SUP2} | 16 | Supply | Channels 3 and 4 Supply Voltage (connected to battery in series with external reverse blocking diode) |
| LIN3 | 17 | I/O | Channel 3 LIN Bus single-wire transmitter and receiver |
| GND1 | 19 | G | Ground pin for Channels 1 and 2 |
| LIN2 | 20 | I/O | Channel 2 LIN Bus single-wire transmitter and receiver |
| V _{SUP1} | 21 | Supply | Channels 1 and 2 Supply Voltage (connected to battery in series with external reverse blocking diode) |
| LIN1 | 22 | I/O | Channel 1 LIN Bus single-wire transmitter and receiver |
| NC | 13, 18, 23, 24 | – | Not Connected |
| Thermal Pad | | – | Can be connected to the PCB ground plane to improve thermal coupling |

(1) I = Input, O = Output, I/O = Input or Output, G = Ground.

7 Specifications

7.1 Absolute Maximum Ratings

(1) (2)

| Symbol | Parameter | MIN | MAX | UNIT |
|-------------|--|------|-----|------|
| V_{SUP} | Supply voltage range (ISO/DIS 17987 Param 10) | -0.3 | 60 | V |
| V_{LIN} | LIN bus input voltage (ISO/DIS 17987 Param 82) | -60 | 60 | V |
| V_{LOGIC} | Logic pin voltage (RXD, TXD, EN) | -0.3 | 6 | V |
| I_O | Logic pin output current | | 8 | mA |
| T_J | Junction temperature range | -55 | 150 | °C |

- (1) Operation outside the Absolute Maximum Ratings may cause permanent device damage. Absolute Maximum Ratings do not imply functional operation of the device at these or any other conditions beyond those listed under Recommended Operating Conditions. If used outside the Recommended Operating Conditions but within the Absolute Maximum Ratings, the device may not be fully functional, and this may affect device reliability, functionality, performance, and shorten the device lifetime.
- (2) All voltage values are with respect to ground terminal.

7.2 ESD Ratings

| ESD Ratings | | | VALUE | UNIT |
|-------------|-------------------------|--|-------------------|------|
| $V_{(ESD)}$ | Electrostatic discharge | Human body model (HBM) classification level 3A: TXD, RXD, EN Pins, per AEC Q100-002 ⁽¹⁾ | ±4000 | V |
| | | Human body model (HBM) classification level 3B: LIN and V_{SUP} Pin with respect to ground | ±8000 | |
| | | Charged device model (CDM) classification level C5, per AEC Q100-011 | All pins ±1500 | |

- (1) AEC Q100-002 indicates that HBM stressing shall be in accordance with the ANSI/ESDA/JEDEC JS-001 specification.

7.3 ESD Ratings - IEC

| ESD and Surge Protection Ratings | | | VALUE | UNIT |
|----------------------------------|---|---|-------|------|
| $V_{(ESD)}$ | Electrostatic discharge, LIN, V_{SUP} to GND ⁽¹⁾ | IEC 62228-2 per ISO 10605 Contact discharge R = 330 Ω, C = 150 pF | ±8000 | V |

7.3 ESD Ratings - IEC (continued)

| ESD and Surge Protection Ratings | | VALUE | UNIT |
|----------------------------------|--|---|------|
| V _{TRAN} | ISO 7637-2 and IEC 62228-2 per IEC 62215-3 transients according to IBEE LIN EMC test specifications ⁽²⁾ (LIN, V _{SUP} to GND) | IEC 62228-2 per IEC 62215-3 12 V electrical systems Pulse 1 | -100 |
| | | IEC 62215-3 24 V electrical systems ⁽²⁾ Pulse 1 | -450 |
| | | IEC 62228-2 per IEC 62215-3 12 V electrical systems 24 V electrical systems ⁽²⁾ Pulse 2 | 75 |
| | | IEC 62228-2 per IEC 62215-3 12 V electrical systems Pulse 3a | -150 |
| | | IEC 62215-3 24 V electrical systems ⁽²⁾ Pulse 3a | -225 |
| | | IEC 62228-2 per IEC 62215-3 12 V electrical systems Pulse 3b | 100 |
| | | IEC 62215-3 24 V electrical systems ⁽²⁾ Pulse 3b | 225 |

- (1) Results given here are specific to the IEC 62228-2 Integrated circuits – EMC evaluation of transceivers – Part 2: LIN transceivers. Testing performed by OEM approved independent 3rd party, EMC report available upon request.
- (2) Verified during characterization.

7.4 Thermal Information

| THERMAL METRIC ⁽¹⁾ | | TLIN2024A | UNIT |
|-------------------------------|--|-----------|------|
| | | RGY (QFN) | |
| | | 24-PINS | |
| R _{ΘJA} | Junction-to-ambient thermal resistance | 34.3 | °C/W |
| R _{ΘJC(top)} | Junction-to-case (top) thermal resistance | 30.8 | °C/W |
| R _{ΘJB} | Junction-to-board thermal resistance | 13.3 | °C/W |
| Ψ _{JT} | Junction-to-top characterization parameter | 0.5 | °C/W |
| Ψ _{JB} | Junction-to-board characterization parameter | 13.3 | °C/W |
| R _{ΘJC(bot)} | Junction-to-case (bottom) thermal resistance | 2.8 | °C/W |

- (1) For more information about traditional and new thermal metrics, see the Semiconductor and IC Package Thermal Metrics application report, SPRA953.

7.5 Recommended Operating Conditions

parameters valid across -40°C ≤ T_A ≤ 125°C (unless otherwise noted)

| PARAMETER - DEFINITION | | MIN | NOM | MAX | UNIT |
|------------------------|-------------------------------------|-----|-----|------|------|
| V _{SUP1/2} | Supply voltage | 4 | | 48 | V |
| V _{LINx} | LIN Bus input voltage | 0 | | 48 | V |
| V _{LOGIC} | Logic Pin Voltage (RXDx, TXDx, ENx) | 0 | | 5.25 | V |
| T _A | Ambient temperature range | -40 | | 125 | °C |
| TSD | Thermal shutdown rising threshold | 165 | | | °C |
| TSD _(HYS) | Thermal shutdown hysteresis | | 15 | | °C |

7.6 Electrical Characteristics

parameters valid across $-40^{\circ}\text{C} \leq T_A \leq 125^{\circ}\text{C}$ (unless otherwise noted)

| PARAMETER | | TEST CONDITIONS | MIN | TYP | MAX | UNIT |
|-------------------------------------|---|--|------|-----|------|------------------|
| Power Supply | | | | | | |
| $V_{\text{SUP1/2}}$ | Operational supply voltage (ISO/DIS 17987 Param 10) | Device is operational beyond the LIN defined nominal supply voltage range; See Figure 8-1 and Figure 8-2 | 4 | | 48 | V |
| $V_{\text{SUP1/2}}$ | Nominal supply voltage (ISO/DIS 17987 Param 10) | Normal and Standby Modes: ramp V_{SUP} while LIN signal is a 10 kHz square wave with 50 % duty cycle and 36V swing; See Figure 8-1 and Figure 8-2 | 4 | | 48 | V |
| | | Sleep Mode | 4 | | 48 | V |
| UV_{SUP} | Under voltage V_{SUP} threshold | | 2.9 | | 3.85 | V |
| UV_{HYS} | Delta hysteresis voltage for V_{SUP} under voltage threshold | | | 0.2 | | V |
| I_{SUP} | Supply current ⁽⁶⁾ | Normal Mode: EN = High, bus dominant: total bus load where $R_{\text{LIN}} > 500 \Omega$ and $C_{\text{LIN}} < 10 \text{ nF}$ | | 1.2 | 8.5 | mA |
| | | Standby Mode: EN = Low, bus dominant: total bus load where $R_{\text{LIN}} > 500 \Omega$ and $C_{\text{LIN}} < 10 \text{ nF}$ | | 1.1 | 3.75 | mA |
| I_{SUP} | Supply current ⁽⁶⁾ | Normal Mode: EN = High, Bus Recessive: LIN = V_{SUP} | | 670 | 1600 | μA |
| | | Standby Mode: EN = Low, Bus Recessive LIN = V_{SUP} | | 20 | 40 | μA |
| | | Sleep Mode: $4.0 \text{ V} < V_{\text{SUP}} < 14 \text{ V}$, LIN = V_{SUP} , EN = 0 V, TXD and RXD Floating | | 10 | 20 | μA |
| | | Sleep Mode: $14 \text{ V} < V_{\text{SUP}} < 36 \text{ V}$, LIN = V_{SUP} , EN = 0 V, TXD and RXD floating | | | 30 | μA |
| RXDx OUTPUT PIN (OPEN DRAIN) | | | | | | |
| V_{OL} | Output Low voltage | Based upon External pull up to V_{CC} ⁽⁴⁾ | | | 0.6 | V |
| I_{OL} | Low level output current, open drain | LIN = 0 V, RXD = 0.4 V | 1.5 | | | mA |
| I_{ILG} | Leakage current, high-level | LIN = V_{SUP} , RXD = 5 V | -5 | 0 | 5 | μA |
| TXDx INPUT PIN | | | | | | |
| V_{IL} | Low level input voltage | | -0.3 | | 0.8 | V |
| V_{IH} | High level input voltage | | 2 | | 5.25 | V |
| V_{HYS} | Input threshold voltage, normal modes & selective wake modes | | | 50 | 500 | mV |
| I_{ILG} | Low level input leakage current | TXD = Low | -5 | 0 | 5 | μA |
| R_{TXD} | Internal pull-down resistor value | | 125 | 350 | 800 | k Ω |
| ENx INPUT PIN | | | | | | |
| V_{IL} | Low level input voltage | | -0.3 | | 0.8 | V |
| V_{IH} | High level input voltage | | 2 | | 5.25 | V |
| V_{HYS} | Hysteresis voltage | By design and characterization | | 50 | 500 | mV |
| I_{ILG} | Low level input current | EN = Low | -5 | 0 | 5 | μA |
| R_{EN} | Internal Pulldown resistor | | 125 | 350 | 800 | k Ω |
| LINx PIN | | | | | | |
| V_{OH} | LIN recessive high-level output voltage ⁽³⁾ | TXD = high, $I_{\text{O}} = 0 \text{ mA}$, $7 \text{ V} \leq V_{\text{SUP}} \leq 48 \text{ V}$ | 0.85 | | | V_{SUP} |
| V_{OH} | LIN recessive high-level output voltage ^{(1) (2)} | TXD = high, $I_{\text{O}} = 0 \text{ mA}$, $7 \text{ V} \leq V_{\text{SUP}} \leq 18 \text{ V}$ | 0.8 | | | V_{SUP} |
| V_{OH} | LIN recessive high-level output voltage ⁽³⁾ | TXD = high, $I_{\text{O}} = 0 \text{ mA}$, $4 \text{ V} \leq V_{\text{SUP}} < 7 \text{ V}$ | 3 | | | V |

7.6 Electrical Characteristics (continued)

parameters valid across $-40^{\circ}\text{C} \leq T_A \leq 125^{\circ}\text{C}$ (unless otherwise noted)

| PARAMETER | | TEST CONDITIONS | MIN | TYP | MAX | UNIT |
|----------------------|---|--|-------|-----|-------|---------------|
| V_{OL} | LIN dominant low-level output voltage ⁽³⁾ | TXD = low, $7\text{ V} \leq V_{SUP} \leq 48\text{ V}$ | | | 0.2 | V_{SUP} |
| V_{OL} | LIN dominant low-level output voltage ⁽¹⁾ ⁽²⁾ | TXD = low, $7\text{ V} \leq V_{SUP} \leq 18\text{ V}$ | | | 0.2 | V_{SUP} |
| V_{OL} | LIN dominant low-level output voltage ⁽³⁾ | TXD = low, $4\text{ V} \leq V_{SUP} < 7\text{ V}$ | | | 1.2 | V |
| $V_{SUP_NON_OP}$ | V_{SUP} where impact of recessive LIN bus < 5% (ISO/DIS 17987 Param 11) | TXD & RXD open, LIN = 4 V to 58 V | -0.3 | | 58 | V |
| I_{BUS_LIM} | Limiting current (ISO/DIS 17987 Param 57) | TXD = 0 V, $V_{LIN} = 48\text{ V}$, $R_{MEAS} = 440\ \Omega$, $V_{SUP} = 48\text{ V}$, $V_{BUSdom} < 4.518\text{ V}$ | 75 | 120 | 300 | mA |
| $I_{BUS_PAS_dom}$ | Receiver leakage current, dominant (ISO/DIS 17987 Param 13) | LIN = 0 V, $V_{SUP} = 24\text{ V}$ Driver off/ recessive; See Figure 8-6 | -2 | | | mA |
| $I_{BUS_PAS_rec1}$ | Receiver leakage current, recessive (ISO/DIS 17987 Param 14) | LIN > V_{SUP} , $8\text{ V} \leq V_{SUP} \leq 48\text{ V}$, Driver off; See Figure 8-7 | | | 20 | μA |
| $I_{BUS_PAS_rec2}$ | Receiver leakage current, recessive (ISO/DIS 17987 Param 14) | LIN = V_{SUP} , Driver off; See Figure 8-7 | -5 | | 5 | μA |
| $I_{BUS_NO_GND}$ | Leakage current, loss of ground (ISO/DIS 17987 Param 60) | GND = V_{SUP} , $0\text{ V} \leq V_{LIN} < 36\text{ V}$, $V_{SUP} = 24\text{ V}$; Figure 8-8 | -2 | | 2 | mA |
| $I_{leak\ gnd(dom)}$ | Leakage current, loss of ground ⁽⁵⁾ | $V_{SUP} = 8\text{ V}$, GND = open, $V_{SUP} = 18\text{ V}$, GND = open $R_{Commander} = 1\text{ k}\Omega$, $C_L = 1\text{ nF}$ $R_{Responder} = 20\text{ k}\Omega$, $C_L = 1\text{ nF}$ LIN = dominant | -1 | | 1 | mA |
| $I_{leak\ gnd(rec)}$ | Leakage current, loss of ground ⁽⁵⁾ | $V_{SUP} = 8\text{ V}$, GND = open, $V_{SUP} = 18\text{ V}$, GND = open $R_{Commander} = 1\text{ k}\Omega$, $C_L = 1\text{ nF}$ $R_{Responder} = 20\text{ k}\Omega$, $C_L = 1\text{ nF}$ LIN = recessive | -100 | | 100 | μA |
| $I_{BUS_NO_BAT}$ | Leakage current, loss of supply (ISO/DIS 17987 Param 61) | $0\text{ V} \leq V_{LIN} \leq 48\text{ V}$, $V_{SUP} = \text{GND}$; See; Figure 8-9 | | | 5 | μA |
| V_{BUSdom} | Low level input voltage (ISO/DIS 17987 Param 62) ⁽³⁾ | LIN dominant (including LIN dominant for wake-up); See Figure 8-4 and Figure 8-3 | | | 0.4 | V_{SUP} |
| V_{BUSrec} | High level input voltage (ISO/DIS 17987 Param 63) ⁽³⁾ | LIN recessive; See Figure 8-4 and Figure 8-3 | 0.6 | | | V_{SUP} |
| V_{IH} | LIN recessive high-level input voltage ⁽¹⁾ ⁽²⁾ | $7\text{ V} \leq V_{SUP} \leq 18\text{ V}$ | 0.47 | | 0.6 | V_{SUP} |
| V_{IL} | LIN dominant low-level input voltage ⁽¹⁾ ⁽²⁾ | $7\text{ V} \leq V_{SUP} \leq 18\text{ V}$ | 0.4 | | 0.53 | V_{SUP} |
| V_{BUS_CNT} | Receiver center threshold (ISO/DIS 17987 Param 64) | $V_{BUS_CNT} = (V_{BUSdom} + V_{BUSrec})/2$ See Figure 8-4 and Figure 8-3 | 0.475 | 0.5 | 0.525 | V_{SUP} |
| V_{HYS} | Hysteresis voltage (ISO/DIS 17987 Param 65) | $V_{HYS} = (V_{BUSrec} - V_{BUSdom})$ See Figure 8-4 and Figure 8-3 | | | 0.175 | V_{SUP} |
| V_{HYS} | Hysteresis voltage (SAE J2602) | $V_{HYS} = V_{IH} - V_{IL}$ See Figure 8-4 and Figure 8-3 | 0.07 | | 0.175 | V_{SUP} |
| V_{SERIAL_DIODE} | Serial diode LIN termination pullup path | $I_{SERIAL_DIODE} = 10\ \mu\text{A}$ | 0.4 | 0.7 | 1 | V |
| R_{PU} | Pullup resistor to V_{SUP} (ISO/DIS 17987 Param 26) | Normal and Standby modes | 20 | 45 | 60 | k Ω |
| I_{RSLEEP} | Pullup current source to V_{SUP} | Sleep mode, $V_{SUP} = 27\text{ V}$, LIN = GND | -20 | | -2 | μA |
| C_{LINPIN} | Capacitance of the LIN pin | $V_{SUP} = 14\text{ V}$ | | | 25 | pF |

(1) SAE 2602 commander node load conditions: 5.5 nF/4 k Ω and 899 pF/20 k Ω

(2) SAE 2602 responder node load conditions: 5.5 nF/875 Ω and 899 pF/900 Ω

(3) ISO 17987 bus load conditions (C_{LINBUS} , R_{LINBUS}) include 1 nF/1 k Ω ; 6.8 nF/660 Ω ; 10 nF/500 Ω .

(4) RXD uses open drain output structure therefore V_{OL} level is based upon microcontroller supply voltage V_{CC} .

(5) $I_{leak\ gnd} = (V_{BAT} - V_{LIN})/R_{Load}$

(6) Values are for each V_{SUP} pin

7.7 Duty Cycle Characteristics

parameters valid across $-40^{\circ}\text{C} \leq T_A \leq 125^{\circ}\text{C}$ (unless otherwise noted)

| PARAMETER | | TEST CONDITIONS | MIN | TYP | MAX | UNIT |
|-------------------|--|---|-------|-----|-------|------|
| D1 _{12V} | Duty Cycle 1 (ISO/DIS 17987 Param 27) ⁽³⁾ | $TH_{REC(MAX)} = 0.744 \times V_{SUP}$, $TH_{DOM(MAX)} = 0.581 \times V_{SUP}$, $V_{SUP} = 7\text{ V to }18\text{ V}$, $t_{BIT} = 50\ \mu\text{s}$ (20 kbps), $D1 = t_{BUS_rec(min)}/(2 \times t_{BIT})$ (See Figure 8-10 , Figure 8-11) | 0.396 | | | |
| D1 _{12V} | Duty Cycle 1 ⁽³⁾ (4) | $TH_{REC(MAX)} = 0.625 \times V_{SUP}$, $TH_{DOM(MAX)} = 0.581 \times V_{SUP}$, $V_{SUP} = 4\text{ V to }7\text{ V}$, $t_{BIT} = 50\ \mu\text{s}$ (20 kbps), $D1 = t_{BUS_rec(min)}/(2 \times t_{BIT})$ (See Figure 8-10 , Figure 8-11) | 0.396 | | | |
| D1 | Duty Cycle 1 ⁽¹⁾ (2) (4) | $TH_{REC(MAX)} = 0.744 \times V_{SUP}$, $TH_{DOM(MAX)} = 0.581 \times V_{SUP}$, $V_{SUP} = 7\text{ V to }18\text{ V}$, $t_{BIT} = 52\ \mu\text{s}$, $D1 = t_{BUS_rec(min)}/(2 \times t_{BIT})$ (See Figure 8-10 , Figure 8-11) | 0.396 | | | |
| D2 _{12V} | Duty Cycle 2 (ISO/DIS 17987 Param 28) ⁽³⁾ | $TH_{REC(MIN)} = 0.422 \times V_{SUP}$, $TH_{DOM(MIN)} = 0.284 \times V_{SUP}$, $V_{SUP} = 7\text{ V to }18\text{ V}$, $t_{BIT} = 50\ \mu\text{s}$ (20 kbps), $D2 = t_{BUS_rec(MAX)}/(2 \times t_{BIT})$ (See Figure 8-10 , Figure 8-11) | | | 0.581 | |
| D2 _{12V} | Duty Cycle 2 ⁽³⁾ (4) | $TH_{REC(MIN)} = 0.546 \times V_{SUP}$, $TH_{DOM(MIN)} = 0.4 \times V_{SUP}$, $V_{SUP} = 4\text{ V to }7\text{ V}$, $t_{BIT} = 50\ \mu\text{s}$ (20 kbps), $D2 = t_{BUS_rec(MAX)}/(2 \times t_{BIT})$ (See Figure 8-10 , Figure 8-11) | | | 0.581 | |
| D2 | Duty Cycle 2 ⁽¹⁾ (2) (4) | $TH_{REC(MIN)} = 0.422 \times V_{SUP}$, $TH_{DOM(MIN)} = 0.284 \times V_{SUP}$, $V_{SUP} = 7\text{ V to }18\text{ V}$, $t_{BIT} = 52\ \mu\text{s}$, $D2 = t_{BUS_rec(MAX)}/(2 \times t_{BIT})$ (See Figure 8-10 , Figure 8-11) | | | 0.581 | |
| D3 _{12V} | Duty Cycle 3 (ISO/DIS 17987 Param 29) ⁽³⁾ | $TH_{REC(MAX)} = 0.778 \times V_{SUP}$, $TH_{DOM(MAX)} = 0.616 \times V_{SUP}$, $V_{SUP} = 7\text{ V to }18\text{ V}$, $t_{BIT} = 96\ \mu\text{s}$ (10.4 kbps), $D3 = t_{BUS_rec(min)}/(2 \times t_{BIT})$ (See Figure 8-10 , Figure 8-11) | 0.417 | | | |
| D3 _{12V} | Duty Cycle 3 ⁽³⁾ (4) | $TH_{REC(MAX)} = 0.645 \times V_{SUP}$, $TH_{DOM(MAX)} = 0.616 \times V_{SUP}$, $V_{SUP} = 4\text{ V to }7\text{ V}$, $t_{BIT} = 96\ \mu\text{s}$ (10.4 kbps), $D3 = t_{BUS_rec(min)}/(2 \times t_{BIT})$ (See Figure 8-10 , Figure 8-11) | 0.417 | | | |
| D3 | Duty Cycle 3 ⁽¹⁾ (2) (4) | $TH_{REC(MAX)} = 0.778 \times V_{SUP}$, $TH_{DOM(MAX)} = 0.616 \times V_{SUP}$, $V_{SUP} = 7\text{ V to }18\text{ V}$, $t_{BIT} = 96\ \mu\text{s}$, $D3 = t_{BUS_rec(min)}/(2 \times t_{BIT})$ (See Figure 8-10 , Figure 8-11) | 0.417 | | | |
| D4 _{12V} | Duty Cycle 4 (ISO/DIS 17987 Param 30) ⁽³⁾ | $TH_{REC(MIN)} = 0.389 \times V_{SUP}$, $TH_{DOM(MIN)} = 0.251 \times V_{SUP}$, $V_{SUP} = 7\text{ V to }18\text{ V}$, $t_{BIT} = 96\ \mu\text{s}$ (10.4 kbps), $D4 = t_{BUS_rec(MAX)}/(2 \times t_{BIT})$ (See Figure 8-10 , Figure 8-11) | | | 0.59 | |
| D4 _{12V} | Duty Cycle 4 ⁽³⁾ (4) | $TH_{REC(MIN)} = 0.422 \times V_{SUP}$, $TH_{DOM(MIN)} = 0.284 \times V_{SUP}$, $V_{SUP} = 4\text{ V to }7\text{ V}$, $t_{BIT} = 96\ \mu\text{s}$ (10.4 kbps), $D4 = t_{BUS_rec(MAX)}/(2 \times t_{BIT})$ (See Figure 8-10 , Figure 8-11) | | | 0.59 | |
| D4 | Duty Cycle 4 ⁽¹⁾ (2) (4) | $TH_{REC(MIN)} = 0.389 \times V_{SUP}$, $TH_{DOM(MIN)} = 0.251 \times V_{SUP}$, $V_{SUP} = 7\text{ V to }18\text{ V}$, $t_{BIT} = 96\ \mu\text{s}$, $D4 = t_{BUS_rec(MAX)}/(2 \times t_{BIT})$ (See Figure 8-10 , Figure 8-11) | | | 0.59 | |

7.7 Duty Cycle Characteristics (continued)

parameters valid across $-40^{\circ}\text{C} \leq T_A \leq 125^{\circ}\text{C}$ (unless otherwise noted)

| PARAMETER | | TEST CONDITIONS | MIN | TYP | MAX | UNIT |
|-------------------|--|---|-------|-----|-------|---------------|
| D1 _{24V} | Duty Cycle 1 (ISO/DIS 17987 Param 72) | $T_{H_{REC}(MAX)} = 0.710 \times V_{SUP}$, $T_{H_{DOM}(MAX)} = 0.544 \times V_{SUP}$, $V_{SUP} = 15\text{ V to }36\text{ V}$, $t_{BIT} = 50\ \mu\text{s}$ (20 kbps), $D1 = t_{BUS_rec(min)}/(2 \times t_{BIT})$ (See Figure 8-10 , Figure 8-11) | 0.33 | | | |
| D2 _{24V} | Duty Cycle 2 (ISO/DIS 17987 Param 73) | $T_{H_{REC}(MIN)} = 0.446 \times V_{SUP}$, $T_{H_{DOM}(MIN)} = 0.302 \times V_{SUP}$, $V_{SUP} = 15.6\text{ V to }36\text{ V}$, $t_{BIT} = 50\ \mu\text{s}$ (20 kbps), $D2 = t_{BUS_rec(MAX)}/(2 \times t_{BIT})$ (See Figure 8-10 , Figure 8-11) | | | 0.642 | |
| D3 _{24V} | Duty Cycle 3 (ISO/DIS 17987 Param 74) | $T_{H_{REC}(MAX)} = 0.744 \times V_{SUP}$, $T_{H_{DOM}(MAX)} = 0.581 \times V_{SUP}$, $V_{SUP} = 7\text{ V to }36\text{ V}$, $t_{BIT} = 96\ \mu\text{s}$ (10.4 kbps), $D3 = t_{BUS_rec(min)}/(2 \times t_{BIT})$ (See Figure 8-10 , Figure 8-11) | 0.386 | | | |
| D4 _{24V} | Duty Cycle 4 (ISO/DIS 17987 Param 75) ⁽⁴⁾ | $T_{H_{REC}(MIN)} = 0.422 \times V_{SUP}$, $T_{H_{DOM}(MIN)} = 0.284 \times V_{SUP}$, $V_{SUP} = 7.6\text{ V to }36\text{ V}$, $t_{BIT} = 96\ \mu\text{s}$ (10.4 kbps), $D4 = t_{BUS_rec(MAX)}/(2 \times t_{BIT})$ (See Figure 8-10 , Figure 8-11) | | | 0.591 | |
| D1 _{LB} | Duty cycle 1 at low battery ^{(1) (2) (4)} | $T_{H_{REC}(MAX)} = 0.665 \times V_{SUP}$, $T_{H_{DOM}(MAX)} = 0.499 \times V_{SUP}$, $V_{SUP} = 5.5\text{ V to }7\text{ V}$, $t_{BIT} = 52\ \mu\text{s}$ | 0.396 | | | |
| D2 _{LB} | Duty cycle 2 at low battery ^{(1) (2) (4)} | $T_{H_{REC}(MAX)} = 0.496 \times V_{SUP}$, $T_{H_{DOM}(MAX)} = 0.361 \times V_{SUP}$, $V_{SUP} = 6.1\text{ V to }7\text{ V}$, $t_{BIT} = 52\ \mu\text{s}$ | | | 0.581 | |
| D3 _{LB} | Duty cycle 3 at low battery ^{(1) (2) (4)} | $T_{H_{REC}(MAX)} = 0.665 \times V_{SUP}$, $T_{H_{DOM}(MAX)} = 0.499 \times V_{SUP}$, $V_{SUP} = 5.5\text{ V to }7\text{ V}$, $t_{BIT} = 96\ \mu\text{s}$ | 0.396 | | | |
| D4 _{LB} | Duty cycle 4 at low battery ^{(1) (2) (4)} | $T_{H_{REC}(MAX)} = 0.496 \times V_{SUP}$, $T_{H_{DOM}(MAX)} = 0.361 \times V_{SUP}$, $V_{SUP} = 6.1\text{ V to }7\text{ V}$, $t_{BIT} = 96\ \mu\text{s}$ | | | 0.581 | |
| Tr-d max | Transmitter propagation delay timings for the duty cycle ^{(1) (2) (4)} Recessive to dominant | $T_{H_{REC}(MAX)} = 0.744 \times V_{SUP}$, $T_{H_{DOM}(MAX)} = 0.581 \times V_{SUP}$, $7\text{ V} \leq V_{SUP} \leq 18\text{ V}$, $t_{BIT} = 52\ \mu\text{s}$ $t_{REC(MAX)_D1} - t_{DOM(MIN)_D1}$ | | | 10.8 | μs |
| Td-r max | Transmitter propagation delay timings for the duty cycle ^{(1) (2) (4)} Dominant to recessive | $T_{H_{REC}(MAX)} = 0.422 \times V_{SUP}$, $T_{H_{DOM}(MAX)} = 0.284 \times V_{SUP}$, $7\text{ V} \leq V_{SUP} \leq 18\text{ V}$, $t_{BIT} = 52\ \mu\text{s}$ $t_{DOM(MAX)_D2} - t_{REC(MIN)_D2}$ | | | 8.4 | μs |
| Tr-d max | Transmitter propagation delay timings for the duty cycle ^{(1) (2) (4)} Recessive to dominant | $T_{H_{REC}(MAX)} = 0.778 \times V_{SUP}$, $T_{H_{DOM}(MAX)} = 0.616 \times V_{SUP}$, $7\text{ V} \leq V_{SUP} \leq 18\text{ V}$, $t_{BIT} = 96\ \mu\text{s}$ $t_{REC(MAX)_D3} - t_{DOM(MIN)_D3}$ | | | 15.9 | μs |
| Td-r max | Transmitter propagation delay timings for the duty cycle ^{(1) (2) (4)} Dominant to recessive | $T_{H_{REC}(MIN)} = 0.389 \times V_{SUP}$, $T_{H_{DOM}(MIN)} = 0.251 \times V_{SUP}$, $7\text{ V} \leq V_{SUP} \leq 18\text{ V}$, $t_{BIT} = 96\ \mu\text{s}$ $t_{DOM(MAX)_D4} - t_{REC(MIN)_D4}$ | | | 17.28 | μs |
| Tr-d max_low | Low battery transmitter propagation delay timings for the duty cycle ^{(1) (2) (4)} Recessive to dominant | $T_{H_{REC}(MAX)} = 0.665 \times V_{SUP}$, $T_{H_{DOM}(MAX)} = 0.499 \times V_{SUP}$, $5.5\text{ V} \leq V_{SUP} \leq 7\text{ V}$, $t_{BIT} = 52\ \mu\text{s}$ $t_{REC(MAX)_low} - t_{DOM(MIN)_low}$ | | | 10.8 | μs |
| Td-r max_low | Low battery transmitter propagation delay timings for the duty cycle ^{(1) (2) (4)} Dominant to recessive | $T_{H_{REC}(MAX)} = 0.496 \times V_{SUP}$, $T_{H_{DOM}(MAX)} = 0.361 \times V_{SUP}$, $6.1\text{ V} \leq V_{SUP} \leq 7\text{ V}$, $t_{BIT} = 52\ \mu\text{s}$ $t_{DOM(MAX)_low} - t_{REC(MIN)_low}$ | | | 8.4 | μs |

(1) SAE 2602 commander node load conditions: 5.5 nF/4 k Ω and 899 pF/20 k Ω

(2) SAE 2602 responder node load conditions: 5.5 nF/875 Ω and 899 pF/900 Ω

- (3) ISO 17987 bus load conditions (C_{LINBUS} , R_{LINBUS}) include 1 nF/1 k Ω ; 6.8 nF/660 Ω ; 10 nF/500 Ω .
- (4) Specified by design

7.8 Switching Characteristics

parameters valid across $-40^{\circ}\text{C} \leq T_A \leq 125^{\circ}\text{C}$ (unless otherwise noted)

| SYMBOL | DESCRIPTION | TEST CONDITIONS | MIN | NOM | MAX | UNIT |
|--------------------|--|--|-----|-----|-----|---------------|
| t_{rx_pdr} | Receiver rising propagation delay time (ISO/DIS 17987 Param 31) | $R_{RXD} = 2.4 \text{ k}\Omega$, $C_{RXD} = 20 \text{ pF}$; (See Figure 8-12 and Figure 8-13) | | | 6 | μs |
| t_{rx_pdf} | Receiver falling propagation delay time (ISO/DIS 17987 Param 31) | | | | 6 | μs |
| t_{rs_sym} | Symmetry of receiver propagation delay time | Rising edge with respect to falling edge, ($trx_sym = trx_pdf - trx_pdr$), $R_{RXD} = 2.4 \text{ k}\Omega$, $C_{RXD} = 20 \text{ pF}$; (See Figure 8-12 and Figure 8-13) | -2 | | 2 | μs |
| t_{LINBUS} | LIN wake-up time (Minimum dominant time on LIN bus for wake-up) | See Figure 8-16 , Figure 9-2 , and Figure 9-3 | 25 | 100 | 150 | μs |
| t_{CLEAR} | Time to clear false wake-up prevention logic if LIN bus had a bus stuck dominant fault (recessive time on LIN bus to clear bus stuck dominant fault) | See Figure 9-3 | 8 | 17 | 50 | μs |
| t_{DST} | Dominant state time out | | 20 | 34 | 80 | ms |
| t_{MODE_CHANGE} | Mode change delay time | Time to change from standby mode to normal mode or normal mode to sleep mode through EN pin; See Figure 8-14 and Figure 9-4 | 2 | | 15 | μs |
| t_{NOMINT} | Normal mode initialization time | Time for normal mode to initialize and data on RXD pin to be valid; See Figure 8-14 | | | 35 | μs |
| t_{PWR} | Power up time | Upon power up time it takes for valid data on RXD | | | 1.5 | ms |

8 Parameter Measurement Information

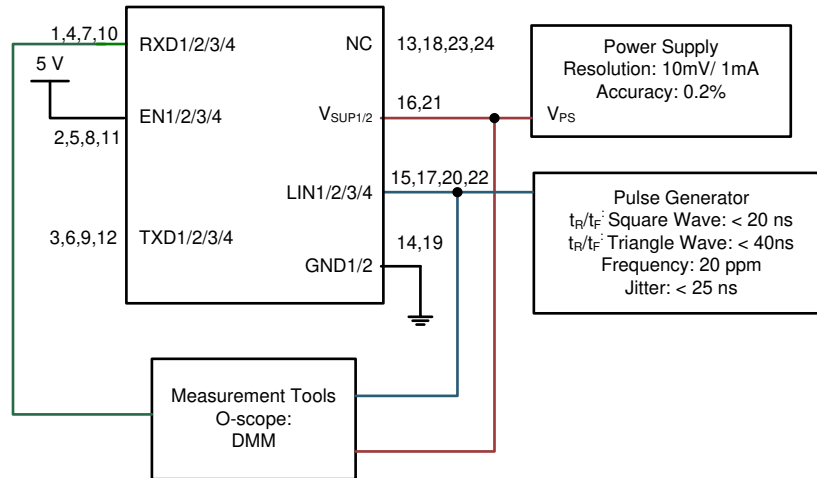

8-1. Test System: Operating Voltage Range with RX and TX Access

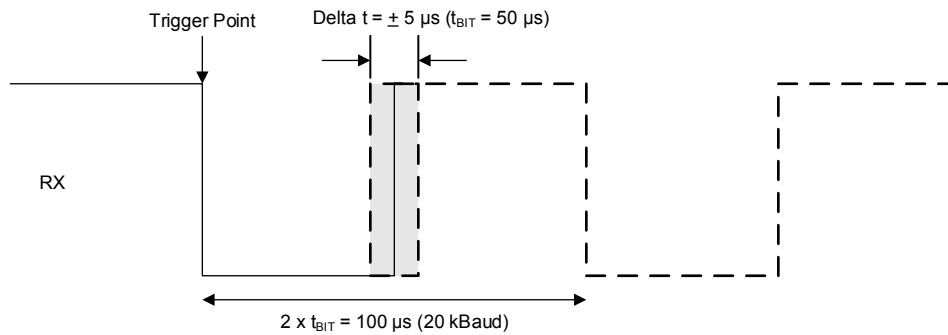

8-2. RX Response: Operating Voltage Range

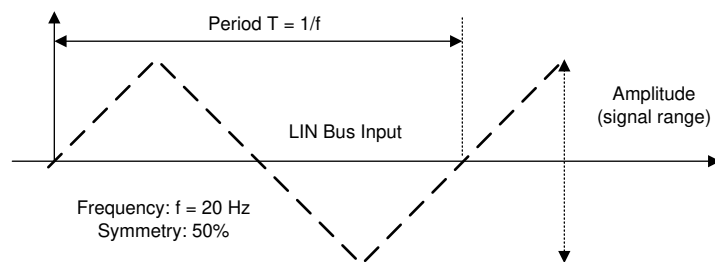

8-3. LIN Bus Input Signal

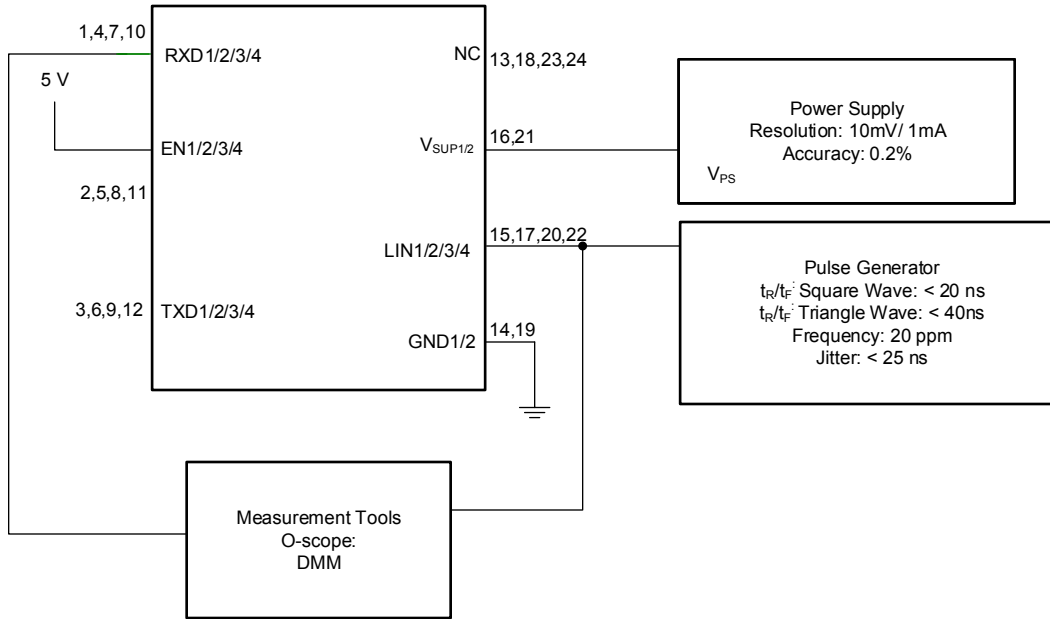

8-4. LIN Receiver Test with RX Access

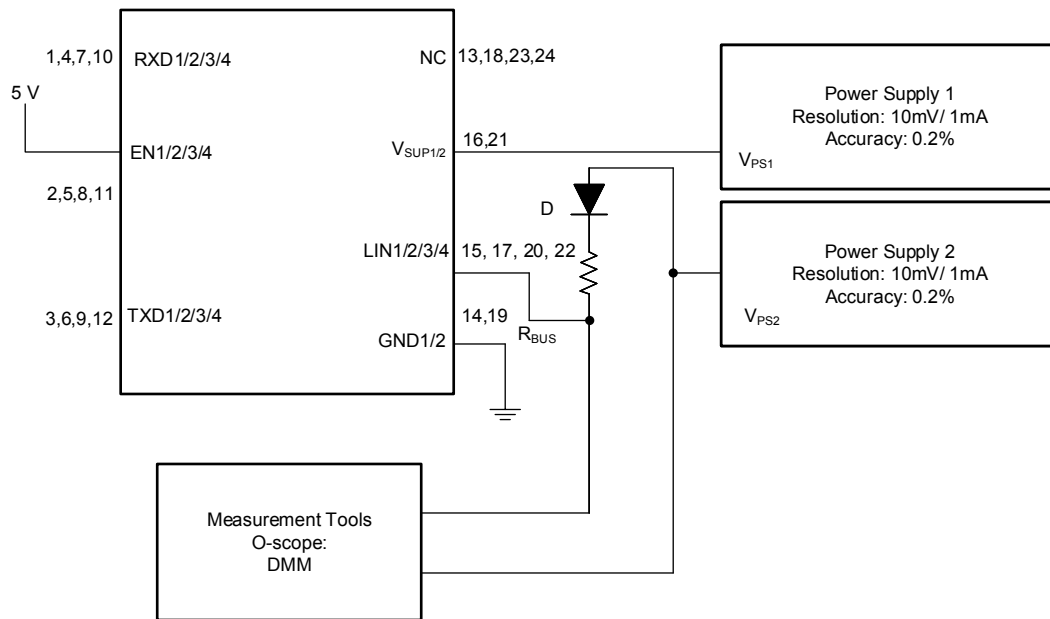

8-5. V_{SUP_NON_OP}

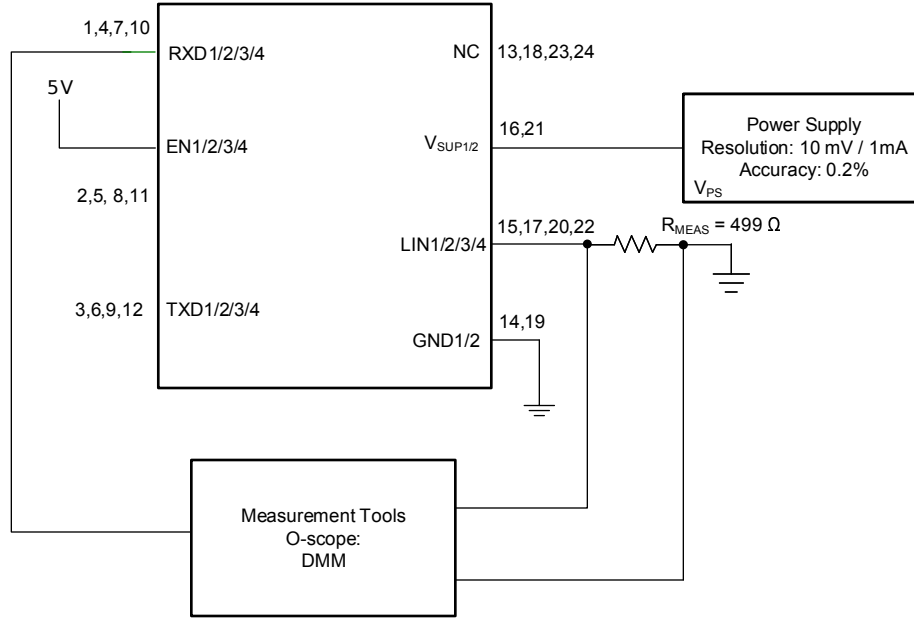

8-6. Test Circuit for $I_{BUS_PAS_dom}$; TXD = Recessive State $V_{BUS} = 0\text{ V}$

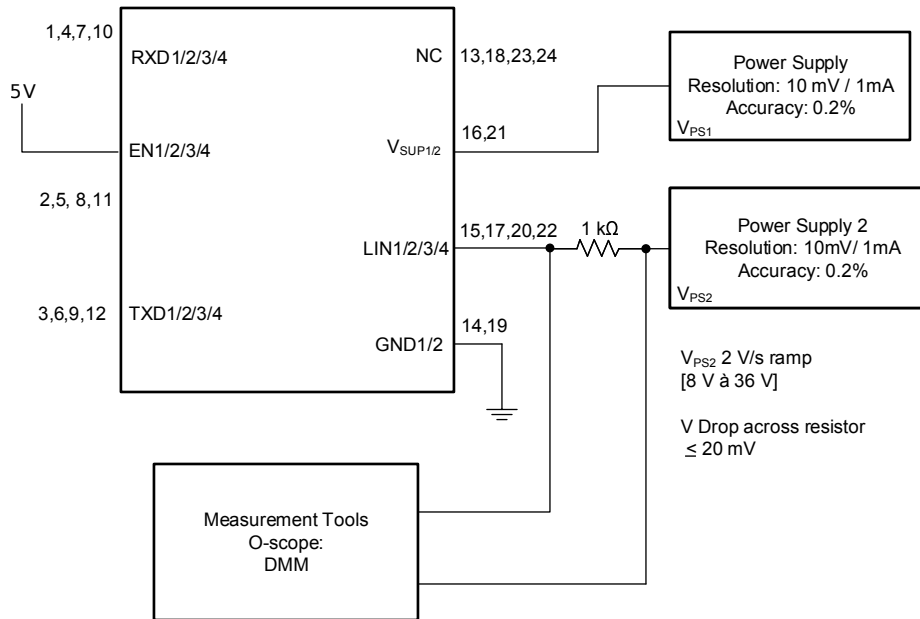

8-7. Test Circuit for $I_{BUS_PAS_rec}$

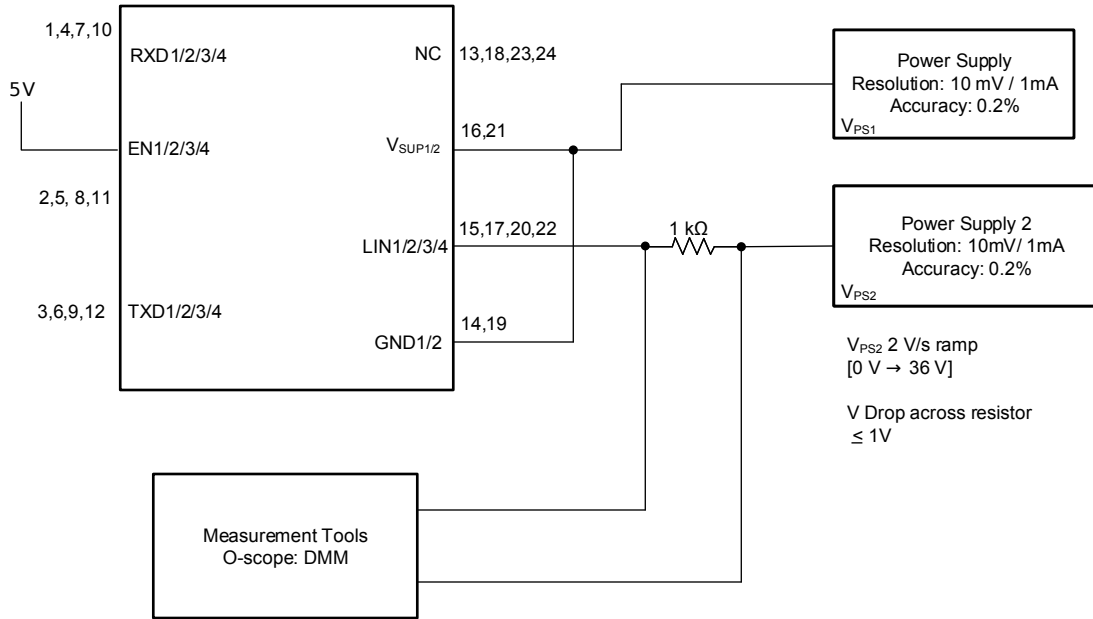

8-8. Test Circuit for $I_{BUS_NO_GND}$ Loss of GND

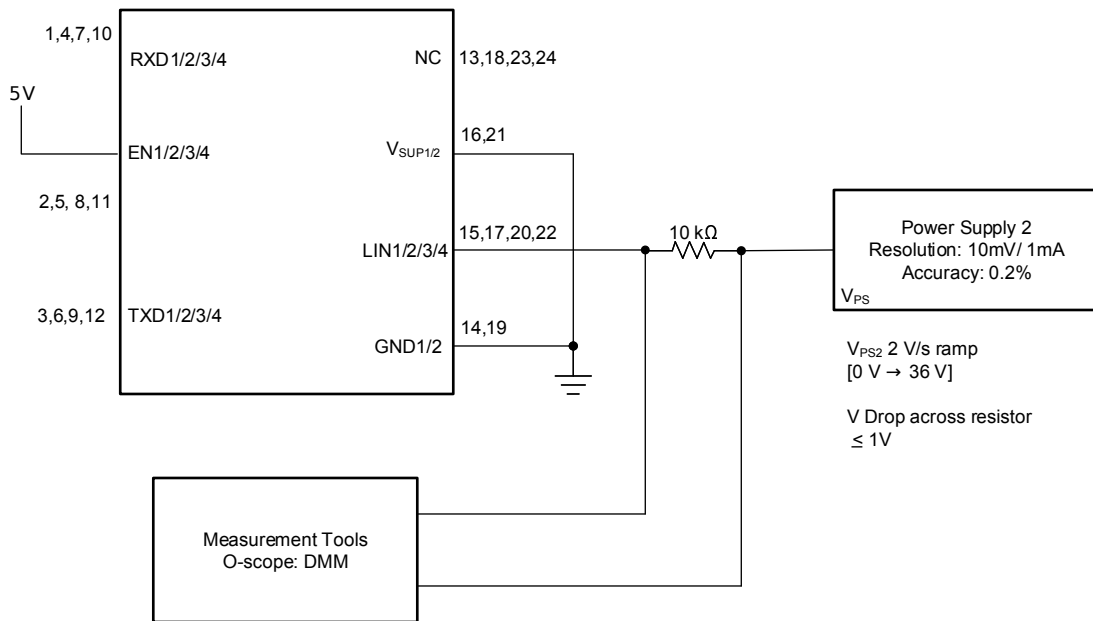

8-9. Test Circuit for $I_{BUS_NO_BAT}$ Loss of Battery

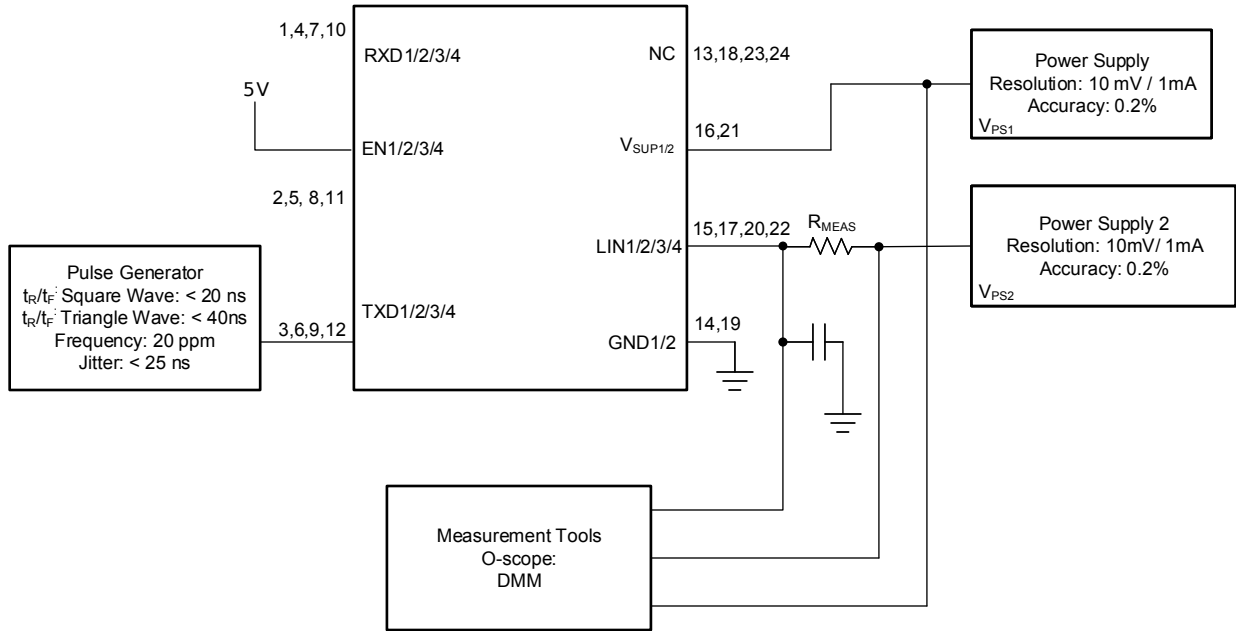

8-10. Test Circuit Slope Control and Duty Cycle

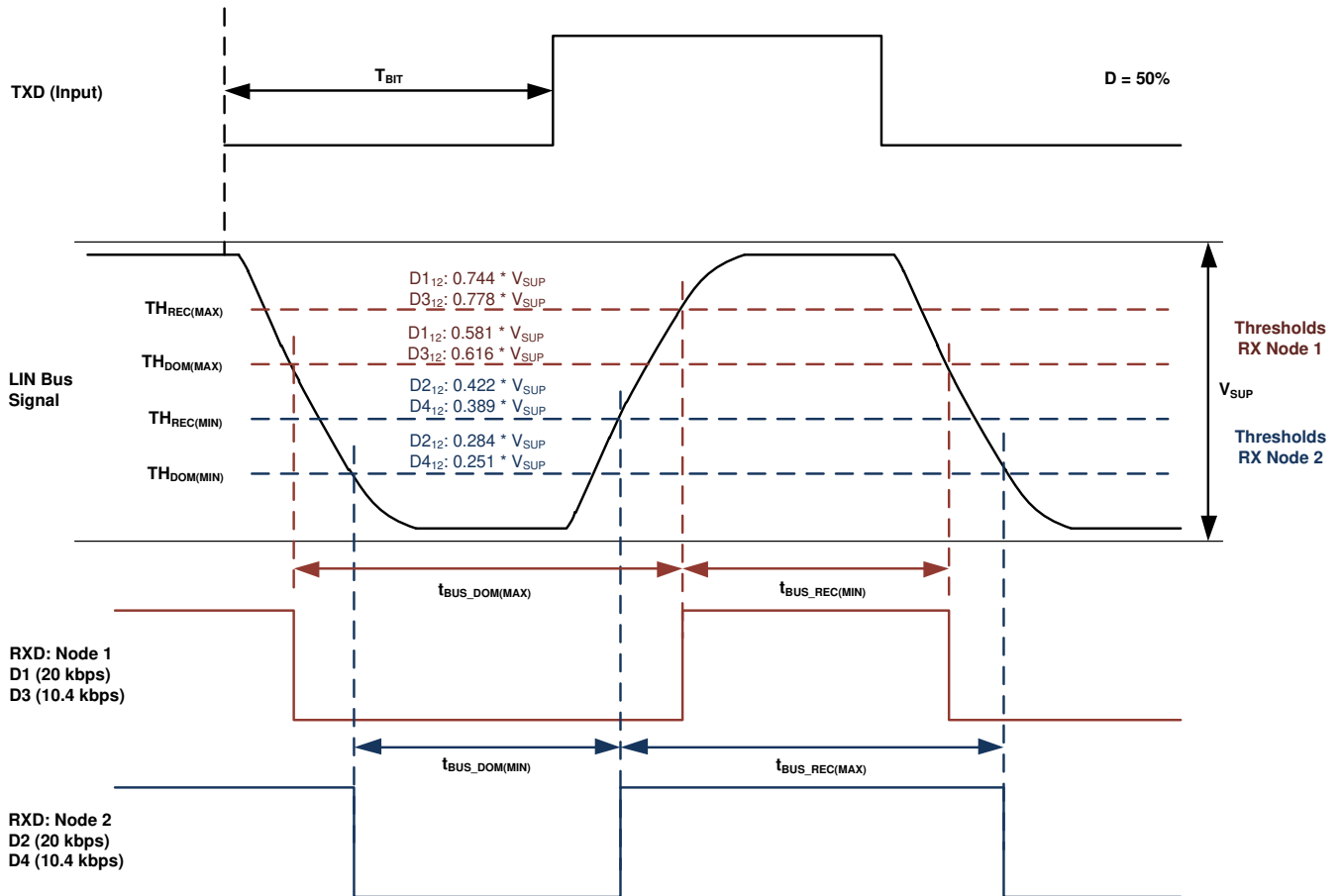

8-11. Definition of Bus Timing Parameters

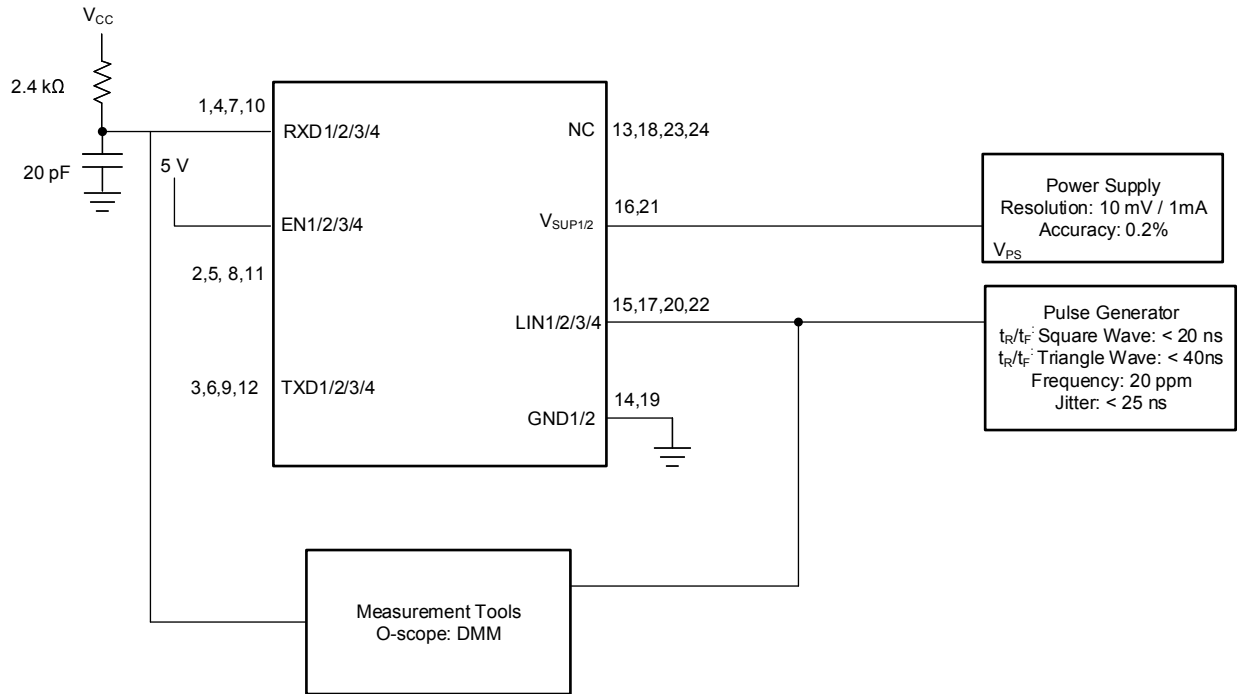

8-12. Propagation Delay Test Circuit

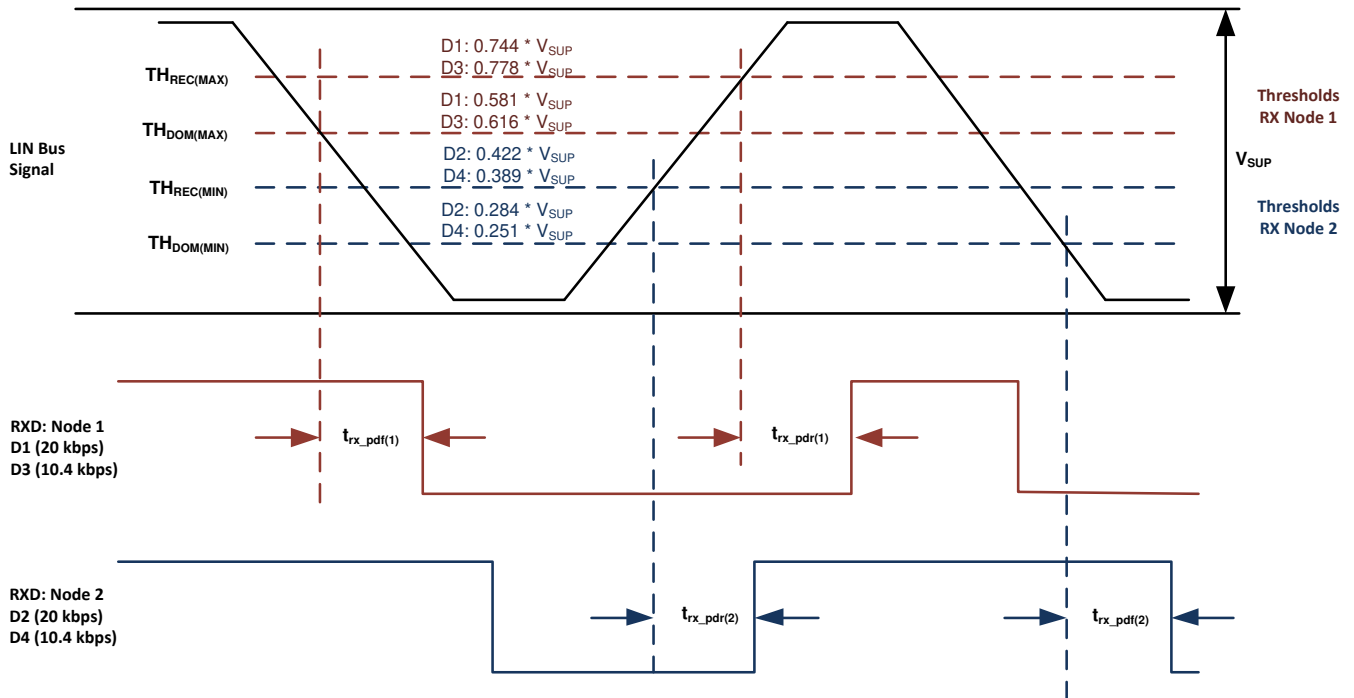

8-13. Propagation Delay

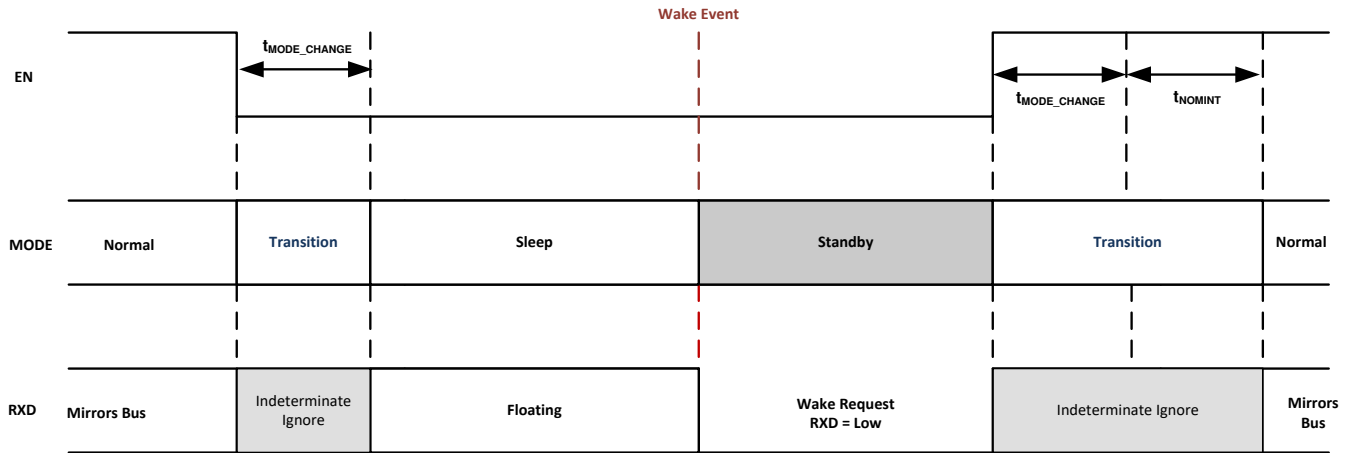

8-14. Mode Transitions

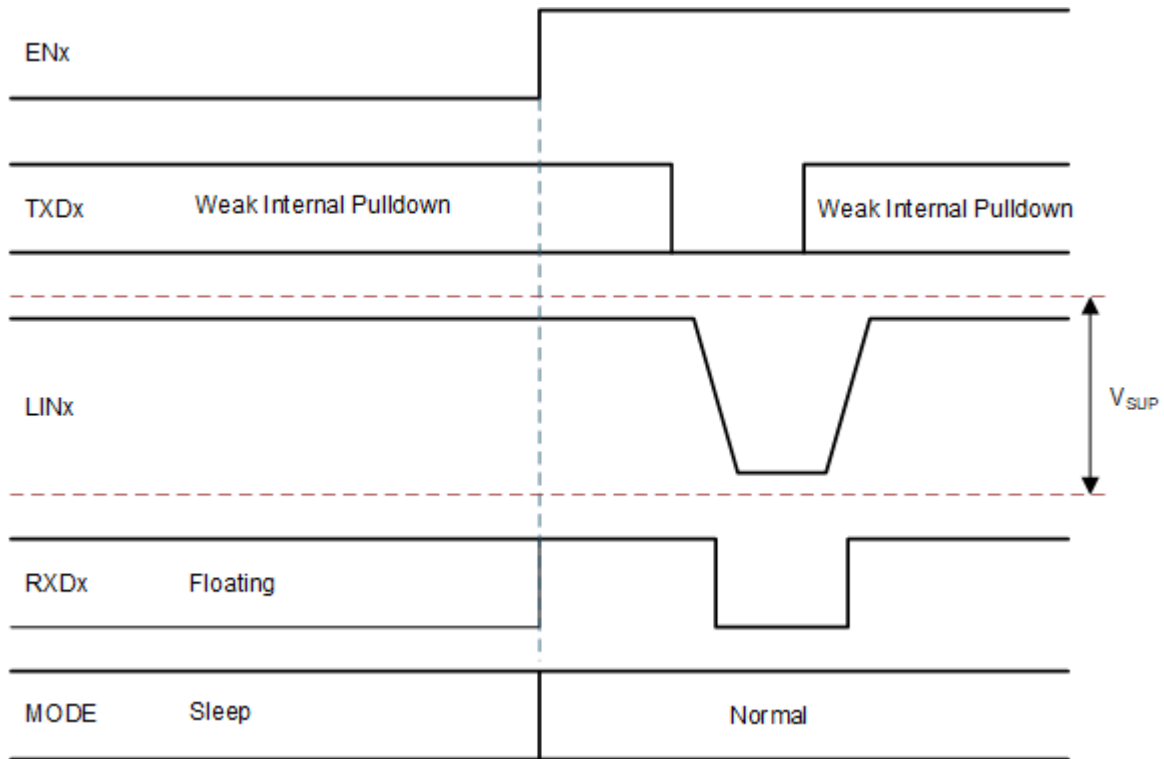

8-15. Wake-Up Through EN

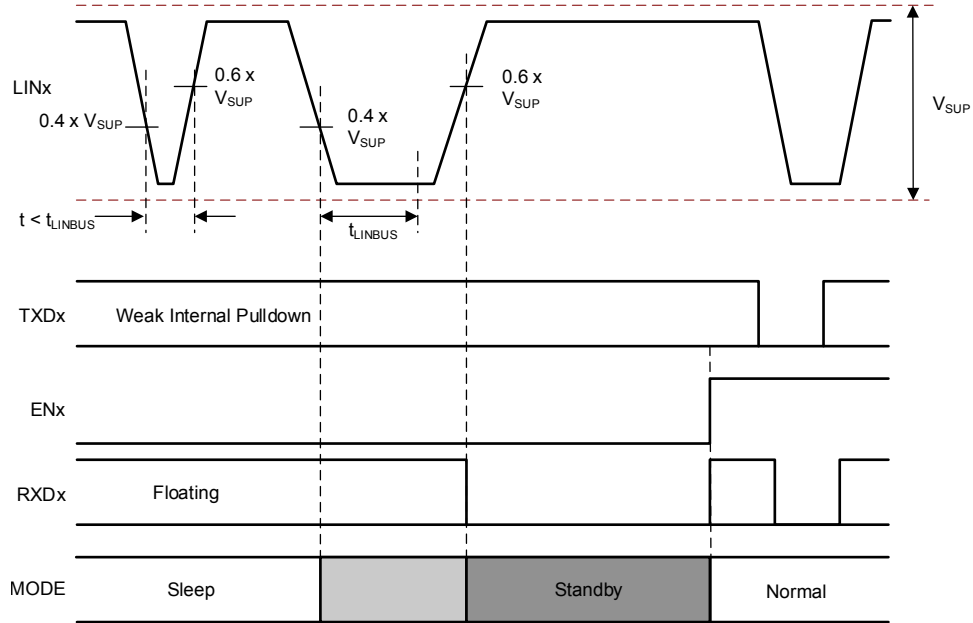

8-16. Wake-Up Through LIN

9 Detailed Description

9.1 Overview

The TLIN2024A-Q1 device is a Quad Local Interconnect Network (LIN) physical layer transceiver, compliant to LIN 2.0, LIN 2.1, LIN 2.2, LIN 2.2A and ISO/DIS 17987–4 standards, with integrated wake-up and protection features. The device has two separate dual LIN transceiver blocks. $V_{SUP1/2}$ provides power to the separate dual transceiver blocks. The LIN bus is a single wire bidirectional bus typically used for low speed in-vehicle networks using data rates up to 20 kbps. The device's LIN receivers work up to 100 kbps supporting in-line programming. The LIN protocol output data stream on the TXD is converted by the device into LIN bus signal using a current-limited wave shaping driver as outlined by the LIN physical layer specification. The receiver converts the data stream to logic level signals that are sent to the microprocessor through the open-drain RXD pin. The LIN bus has two states: dominant state (voltage near ground) and recessive state (voltage near battery). In the recessive state, the LIN bus is pulled high by the internal pull-up resistor (45 k Ω) and a series diode. No external pull-up components are required for responder node applications. Commander node applications require an external pull-up resistor (1 k Ω) plus a series diode per the LIN specification.

The device is designed to support 12-V and 24-V applications with a wide input voltage operating range and also supports low-power sleep mode. The device also provides two methods to wake-up: EN pin and from the LIN bus.

The TLIN2024A-Q1 integrates ESD protection and fault protection which allow for a reduction in the required external components in the applications. In the event of a ground shift or supply voltage disconnection, the device prevents back-feed current through LIN to the supply input. The device also includes undervoltage detection, temperature shutdown protection, and loss-of-ground protection.

V_{SUP1} and GND1 supplies transceivers 1 and 2 while V_{SUP2} and GND2 supplies transceiver 3 and 4. The device is part of the LIN family that includes the TLIN2022A and TLIN2029A LIN transceivers.

9.2 Functional Block Diagram

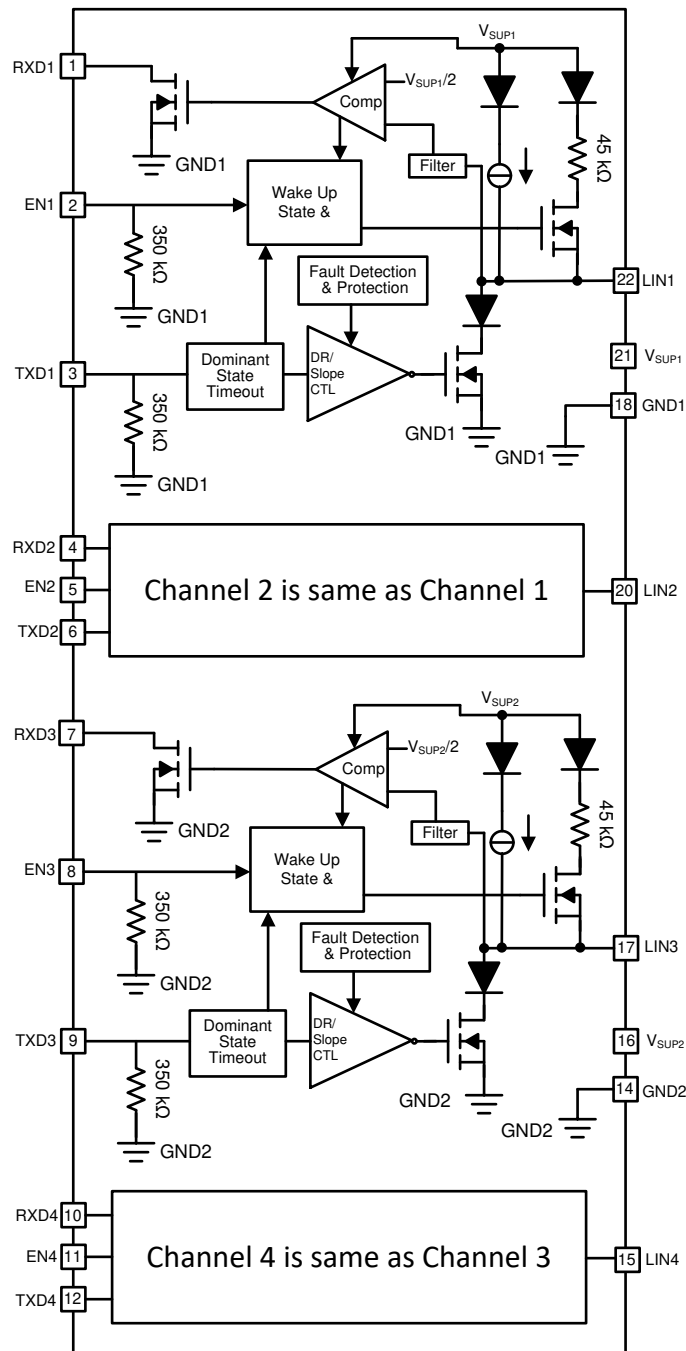

9.3 Feature Description

9.3.1 LIN (Local Interconnect Network) Bus

These high voltage input/output pins are single wire LIN bus transmitters and receivers. The LIN pins can survive excessive DC and transient voltages up to 60 V. Reverse currents from the LIN pins to supply ($V_{SUP1/2}$) are minimized with blocking diodes, even in the event of a ground shift or loss of supply ($V_{SUP1/2}$).

9.3.1.1 LIN Transmitter Characteristics

The transmitter has thresholds and AC parameters according to the LIN specification. The transmitter is a low side transistor with and internal current limitation and thermal shutdown. During a thermal shutdown condition, the transmitter is disabled to protect the device. There is an internal pull-up resistor with a serial diode structure

to $V_{SUP1/2}$, so no external pull-up components are required for the LIN responder node applications. An external pull-up resistor and series diode to $V_{SUP1/2}$ must be added when the device is used for a commander node application.

9.3.1.2 LIN Receiver Characteristics

The receiver characteristic thresholds are proportional with the device supply pin according to the LIN specification.

The receiver is capable of receiving higher data rates (> 100 kbps) than supported by LIN or SAE J2602 specifications. This allows the TLIN2024A-Q1 to be used for high speed downloads at the end-of-line production or other applications. The actual data rate achievable depends on system time constants (bus capacitance and pull-up resistance) and driver characteristics used in the system.

9.3.1.2.1 Termination

There is an internal pull-up resistor with a serial diode structure to $V_{SUP1/2}$, so no external pull-up components are required for the LIN responder node applications. An external pull-up resistor ($1\text{ k}\Omega$) and a series diode to $V_{SUP1/2}$ must be added when the device is used for commander node applications as per the LIN specification.

Figure 9-1 shows a commander node configuration and how the voltage levels are defined

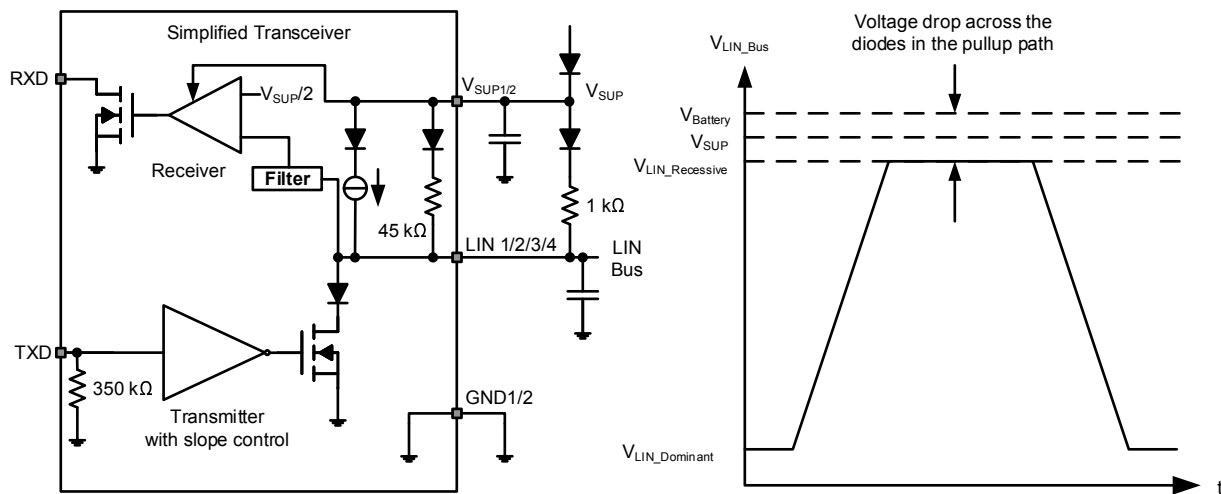

Figure 9-1. Commander Node Configuration with Voltage Levels

9.3.2 TXD (Transmit Input and Output)

TXD is the interface to the processor's LIN protocol controller or SCI/UART that is used to control the state of the LIN output. When TXD is low the LIN output is dominant (near ground). When TXD is high the LIN output is recessive (near $V_{Battery}$). See Figure 9-1. The TXD input structure is compatible with microprocessors with 3.3 V and 5 V I/O. TXD has an internal pull-down resistor. The LIN bus is protected from being stuck dominant through a system failure driving TXD low through the dominant state timeout timer.

9.3.3 RXD (Receive Output)

RXD is the interface to the processor's LIN protocol controller or SCI/UART, which reports the state of the LIN bus voltage. LIN recessive (near $V_{Battery}$) is represented by a high level on the RXD and LIN dominant (near ground) is represented by a low level on the RXD pin. The RXD output structure is an open-drain output stage. This allows the device to be used with 3.3 V and 5 V I/O microprocessors. If the microprocessor's RXD pin does not have an integrated pull-up, an external pull-up resistor to the microprocessor I/O supply voltage is required. In standby mode the RXD pin is driven low to indicate a wake-up request from the LIN bus.

9.3.4 $V_{SUP1/2}$ (Supply Voltage)

$V_{SUP1/2}$ are the power supply pins. $V_{SUP1/2}$ is connected to the battery through an external reverse battery blocking diode (See Figure 9-1). If there is a loss of power at the ECU level, the device has extremely low leakage

from the LIN pin, which does not load the bus down. This is optimal for LIN systems in which some of the nodes are unpowered (ignition supplied) while the rest of the network remains powered (battery supplied).

9.3.5 GND1/2 (Ground)

GND1 and GND2 are the ground connections for LIN1/2 and LIN3/4 channels respectively. V_{SUP1} is referred to GND1 and V_{SUP2} is referred to GND2. The device can operate with a ground shift as long as the ground shift does not reduce $V_{SUP1/2}$ below the minimum operating voltage. If there is a loss of ground at the ECU level, the device has a low leakage from the LIN pin, which does not load the bus down. This is optimal for LIN systems in which some of the nodes are unpowered (ignition supplied) while the rest of the network remains powered (battery supplied).

9.3.6 EN (Enable Input)

EN1, EN2, EN3 and EN4 control the operational modes of the respective LIN channel. When EN1/EN2/EN3/EN4 is high, the LIN1/LIN2/LIN3/LIN4 channel is in normal operating mode allowing a transmission path from TXD to LIN and from LIN to RXD. When either of the EN pins is low, the respective LIN channel is put into sleep mode and there is no transmission path available. The device can enter normal mode only after wake-up. EN has an internal pull-down resistor to ensure the device remains in low power mode even if EN floats.

9.3.7 Protection Features

The TLIN2024A-Q1 has several protection features.

9.3.8 TXD Dominant Time Out (DTO)

During normal mode, if TXD is inadvertently driven permanently low by a hardware or software application failure, the LIN bus is protected by the dominant state timeout timer. This timer is triggered by a falling edge on the TXD pin. If the low signal remains on TXD for longer than t_{DST} , the transmitter is disabled, thus allowing the LIN bus to return to recessive state and communication to resume on the bus. The protection is cleared and the t_{DST} timer is reset by a rising edge on TXD. The TXD pin has an internal pull-down to ensure the device fails to a known state if TXD is disconnected. During this fault, the transceiver remains in normal mode (assuming no change of state request on EN), the transmitter is disabled, the RXD pin reflects the LIN bus and the LIN bus pull-up termination remains on.

9.3.9 Bus Stuck Dominant System Fault: False Wake-Up Lockout

The TLIN2024A-Q1 contains logic to detect bus stuck dominant system faults and prevents the device from waking up falsely during the system fault. Upon entering sleep mode, the device detects the state of the LIN bus. If the bus is dominant, the wake-up logic is locked out until a valid recessive on the bus “clears” the bus stuck dominant, preventing excessive current use. [Figure 9-2](#) and [Figure 9-3](#) show the behavior of this protection.

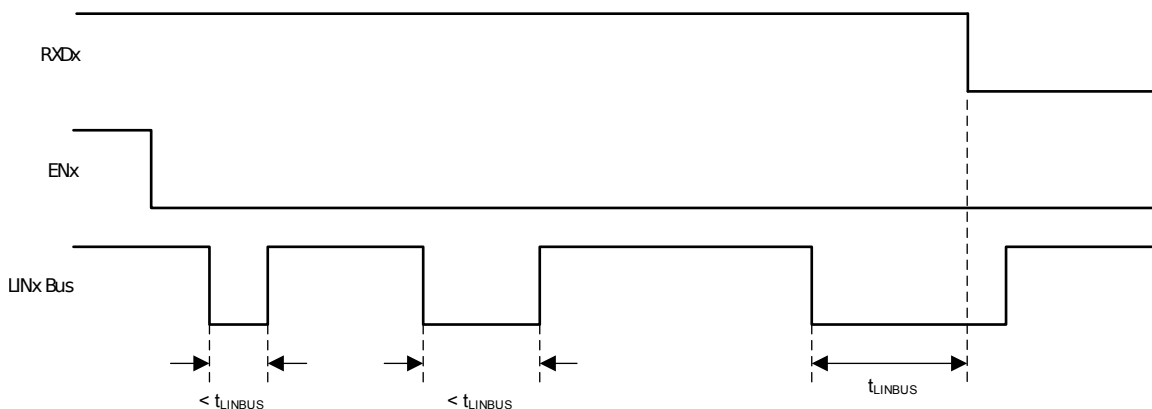

Figure 9-2. No Bus Fault: Entering Sleep Mode with Bus Recessive Condition and Wake-up



图 9-3. Bus Fault: Entering Sleep Mode with Bus Stuck Dominant Fault, Clearing, and Wake-up

9.3.10 Thermal Shutdown

The LIN transmitter is protected by limiting the current; however if the junction temperature of the device exceeds the thermal shutdown threshold, the device puts the LIN transmitter into the recessive state. Once the over temperature fault condition has been removed and the junction temperature has cooled beyond the hysteresis temperature, the transmitter is re-enabled, assuming the device remains in the normal operation mode. During this fault, the transceiver remains in normal mode (assuming no change of state request on EN), the transmitter is in recessive state, the RXD pin reflects the LIN bus and LIN bus pull-up termination remains on.

9.3.11 Under Voltage on V_{SUP}

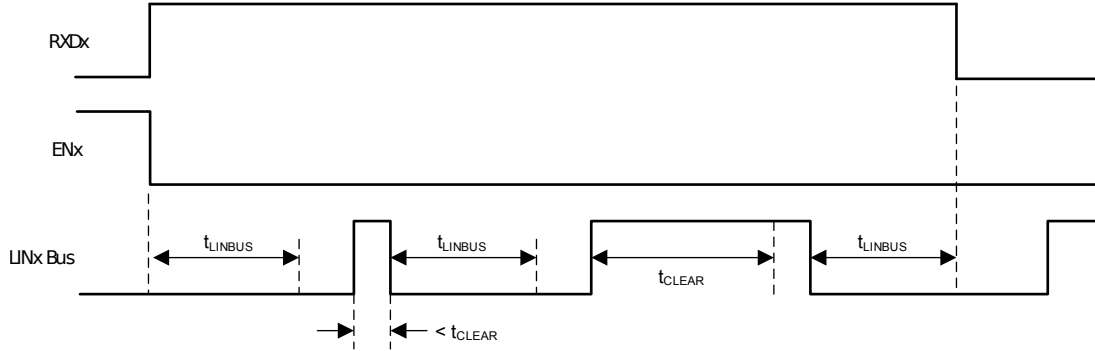
The TLIN2024A-Q1 contains a power on reset circuit to avoid false bus messages during under voltage conditions when $V_{SUP1/2}$ is less than $UV_{SUP1/2}$.

9.3.12 Unpowered Device and LIN Bus

In automotive applications some LIN nodes in a system can be unpowered (ignition supplied) while others in the network remains powered by the battery. The TLIN2024A-Q1 has a low unpowered leakage current from the bus so an unpowered node does not affect the network or load it down.

9.4 Device Functional Modes

The TLIN2024A-Q1 has three functional modes of operation, normal, sleep, and standby. The next sections describe these modes as well as how the device moves between the different modes. [图 9-4](#) graphically shows the relationship while [表 9-1](#) shows the state of pins.

表 9-1. Operating Modes

| MODE | ENx | RXDx | LIN BUS TERMINATION | TRANSMITTER | COMMENT |
|---------|------|---------------|----------------------|-------------|--|
| Sleep | Low | Floating | Weak Current Pull-up | Off | |
| Standby | Low | Low | 45 kΩ (typical) | Off | Wake-up event detected, waiting on MCU to set EN |
| Normal | High | LINx Bus Data | 45 kΩ (typical) | On | LINx transmission up to 20 kbps |



图 9-4. Operating State Diagram

9.4.1 Normal Mode

The EN pin controls the mode of the channel. If the EN1/EN2/EN3/EN4 pin is high at power up, the channel powers up in normal mode. In normal operational mode, the receiver and transmitter are active and the LIN transmission up to the LIN specified maximum of 20 kbps is supported. The receiver detects the data stream on the LIN bus and outputs it on RXD for the LIN controller. A recessive signal on the LIN bus is a digital high and a dominant signal on the LIN bus is a digital low. The driver transmits input data from TXD to the LIN bus. Normal mode is entered as EN transitions high while the LIN channel is in sleep or standby mode for $> t_{MODE_CHANGE}$ plus t_{NOMINT} .

9.4.2 Sleep Mode

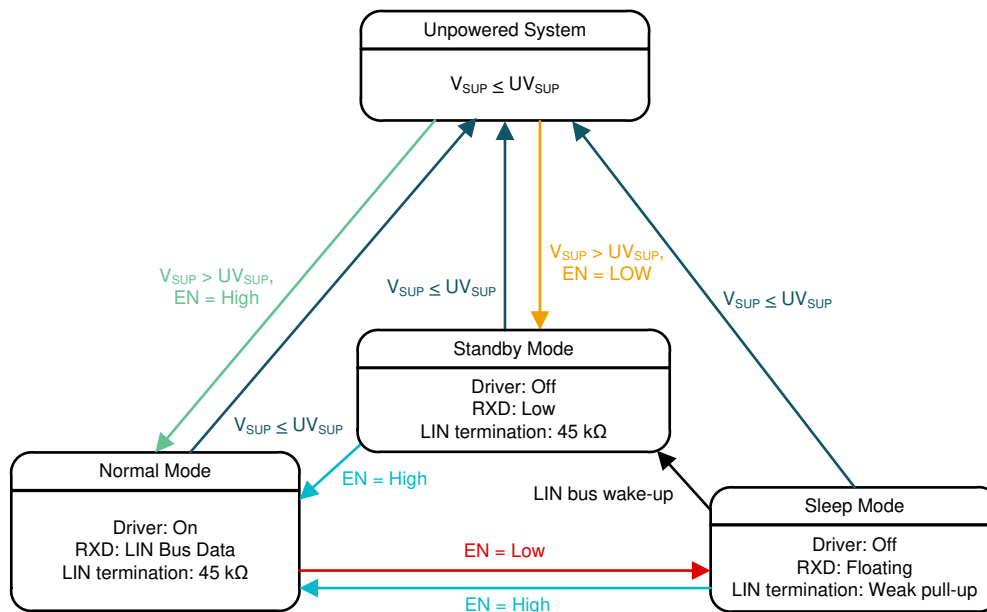
Sleep Mode is the power saving mode for the TLIN2024A-Q1. Even with extremely low current consumption in this mode, the LIN channel can still wake-up from LIN bus through a wake-up signal or if EN is set high for $> t_{\text{MODE_CHANGE}}$. The LIN bus is filtered to prevent false wake-up events. The wake-up events must be active for the respective time periods (t_{LINBUS}).

The sleep mode is entered by setting EN low for longer than $t_{\text{MODE_CHANGE}}$.

While the device is in sleep mode, the following conditions exist.

- The LIN bus driver is disabled and the internal LIN bus termination is switched off (to minimize power loss if LIN is short circuited to ground). However, the weak current pull-up is active to prevent false wake-up events in case an external connection to the LIN bus is lost.
- The normal receiver is disabled.
- EN input and LIN wake-up receiver are active.

9.4.3 Standby Mode

If the device powers up with any of the ENx pins held low, the corresponding LINx channel is in standby mode. Standby mode is also entered whenever a wake-up event occurs through the LIN bus while the device is in sleep mode. The LIN bus responder termination circuit is turned on when standby mode is entered. Standby mode is signaled through a low level on RXD. See [Standby Mode Application Note](#) for more application information.

When EN is set high for longer than $t_{\text{MODE_CHANGE}}$ while the device is in standby mode the device returns to normal mode and the normal transmission paths from TXD to LIN bus and LIN bus to RXD are enabled.

9.4.4 Wake-Up Events

There are two ways to wake-up from sleep mode:

- Remote wake-up initiated by the falling edge of a recessive (high) to dominant (low) state transition on LIN bus where the dominant state is held for t_{LINBUS} filter time. After this t_{LINBUS} filter time has been met and a rising edge on the LIN bus going from dominant state to recessive state initiates a remote wake-up event, eliminating false wake-ups from disturbances on the LIN bus or if the bus is shorted to ground.
- Local wake-up through EN being set high for longer than $t_{\text{MODE_CHANGE}}$.

9.4.4.1 Wake-Up Request (RXD)

When the TLIN2024A-Q1 encounters a wake-up event from the LIN bus, RXD goes low and the channel transitions to standby mode until EN is reasserted high and the channel enters normal mode. Once the channel enters normal mode the RXD pin releases the wake-up request signal and the RXD pin then reflects the receiver output from the LIN bus.

9.4.4.2 Mode Transitions

When the TLIN2024A-Q1 is transitioning between modes the device needs the time, $t_{\text{MODE_CHANGE}}$, to allow the change to fully propagate from the EN pin through the device into the new state. When transitioning from sleep or standby mode to normal mode the transition time is the sum of $t_{\text{MODE_CHANGE}}$ and t_{NOMINT} .

10 Application and Implementation Disclaimer

Note

Information in the following applications sections is not part of the TI component specification, and TI does not warrant its accuracy or completeness. TI's customers are responsible for determining suitability of components for their purposes, as well as validating and testing their design implementation to confirm system functionality.

10.1 Application Information

The TLIN2024A-Q1 can be used as both a responder device and a commander device in a LIN network. The device comes with the ability to support both remote wake-up request and local wake-up request.

10.2 Typical Application

The device comes with an integrated 45 kΩ pull-up resistor and series diode for responder node applications. For commander node applications, an external 1 kΩ pull-up resistor with series blocking diode can be used. [Typical LIN Bus](#) shows the device being used in both commander and responder applications.

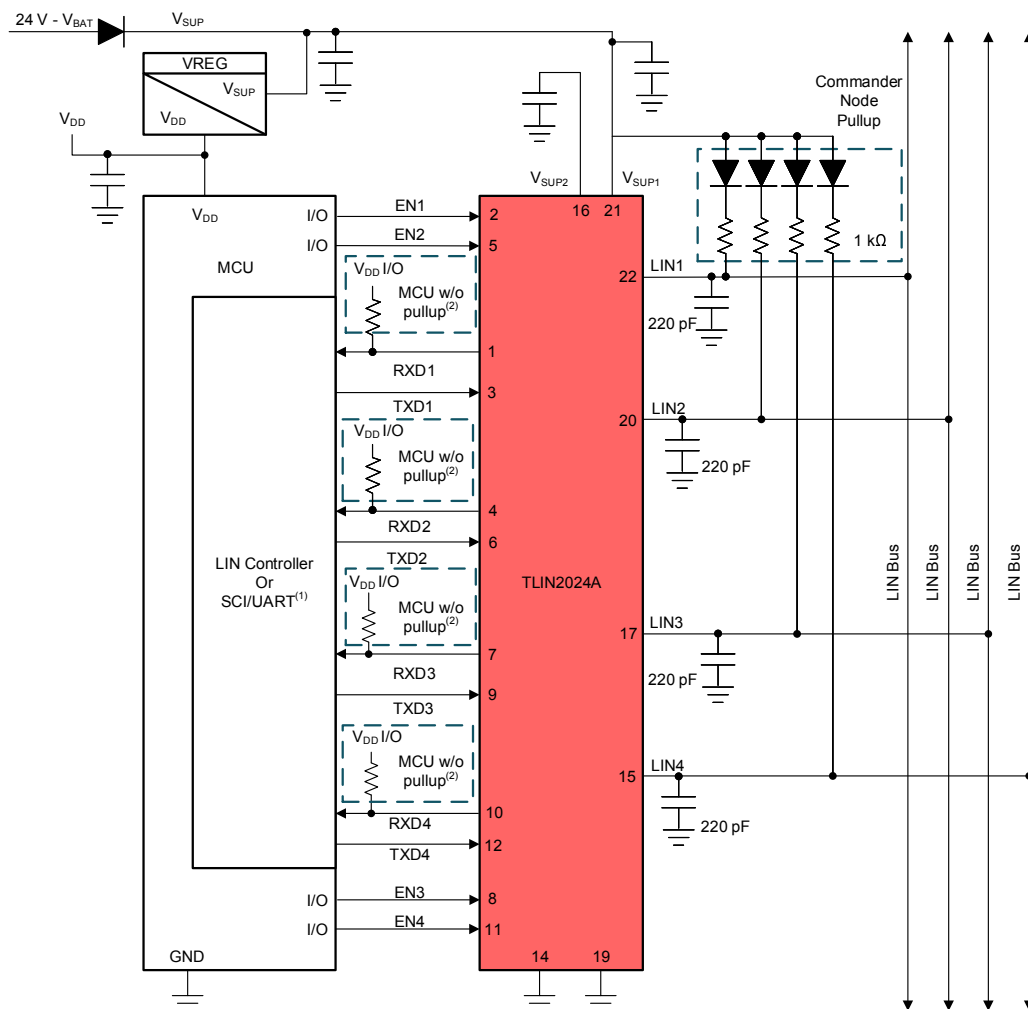

- (1) If RXD on MCU, or LIN transceiver, has an internal pull-up, then an external pull-up resistor is not required.
- (2) If RXD on MCU, or LIN transceiver, does not have an internal pull-up, then an external pull-up resistor is required.
- (3) Commander node applications require an external 1 kΩ pull-up resistor and serial diode.
- (4) Decoupling capacitor values are system dependent but usually have 100 nF, 1 μF and ≥10 μF

10-1. Typical LIN Bus

10.2.1 Design Requirements

The RXD output structure is an open-drain output stage. This allows the TLIN2024A-Q1 to be used with 3.3 V and 5 V I/O microprocessors. If the RXD pin of the microprocessor does not have an integrated pull-up, an external pull-up resistor to the microprocessor I/O supply voltage is required.

The $V_{SUP1/2}$ pins of the device should be decoupled with a 100 nF capacitor as close to the supply pin on the device as possible. The system should include additional decoupling on the V_{SUP} line as needed per the application requirements.

10.2.1.1 Detailed Design Procedures

10.2.1.2 Normal Mode Application Note

When using the TLIN2024A-Q1 in systems which are monitoring the RXD pin for a wake-up request, special care should be taken during the mode transitions. The output of the RXD pin is indeterminate for the transition period between states as the receivers are switched. The application software should not look for an edge on the RXD pin indicating a wake-up request until t_{MODE_CHANGE} when going from sleep or standby to normal mode. This is shown in [Mode Transitions](#)

10.2.1.3 Standby Mode Application Note

If the TLIN2024A-Q1 detects an under voltage on $V_{SUP1/2}$, the RXD pin transitions low and would signal to the software that the device is in standby mode and should be returned to sleep mode for the lowest power state.

10.2.1.4 TXD Dominant State Timeout Application Note

The maximum dominant TXD time allowed by the TXD dominant state time out limits the minimum possible data rate of the device. The LIN protocol has different constraints for commander and responder applications thus there are different maximum consecutive dominant bits for each application case and thus different minimum data rates.

10.2.2 Application Curves

☒ 10-2 and ☒ 10-3 show the propagation delay from the TXD pin to the LIN pin for both dominant to recessive and recessive to dominant edges. Waveforms are for 1 channel of the device configured in commander mode with external pull-up resistor (1 k Ω) and 680 pF bus capacitance.

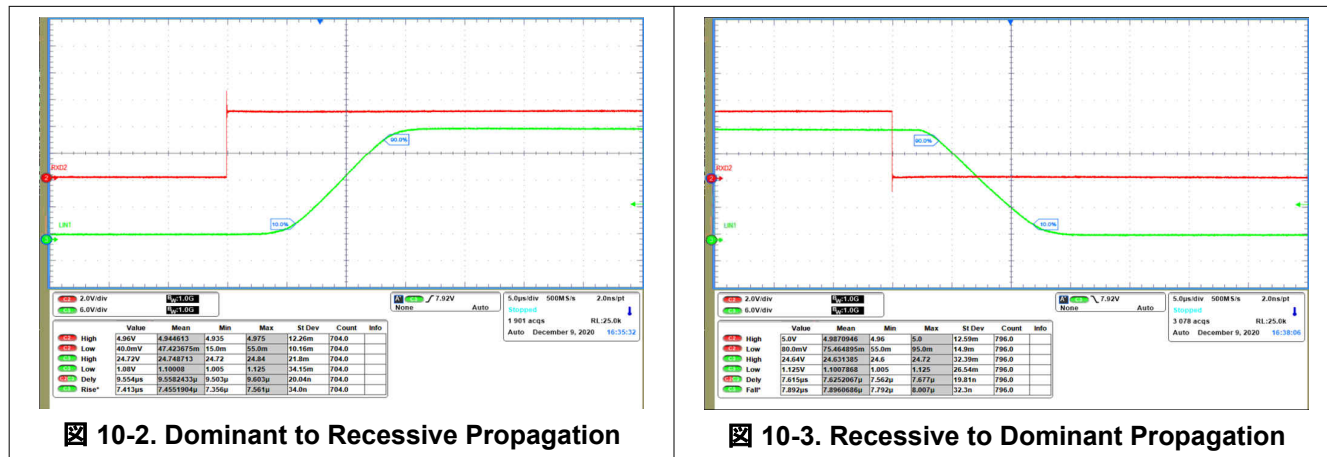

10.3 Power Supply Recommendations

The TLIN2024A-Q1 was designed to operate directly off a car battery, or any other DC supply ranging from 4 V to 48 V. A 100 nF decoupling capacitor should be placed as close to the $V_{SUP1/2}$ pin of the device as possible. It is good practice for some applications with noisier supplies to include 1 μ F and 10 μ F decoupling capacitor.

10.4 Layout

In order for the PCB design to be successful, start with the design of the protection and filtering circuitry. Because ESD and EFT transients have a wide frequency bandwidth from approximately 3 MHz to 3 GHz, high frequency layout techniques must be applied during PCB design. Placement at the connector also prevents these noisy events from propagating further into the PCB and system.

10.4.1 Layout Guidelines

- **Pins 1, 4, 7 and 10 (RXD1/2/3/4):** The pins are open drain outputs and require an external pull-up resistor in the range of 1 k Ω and 10 k Ω to function properly. If the microprocessor paired with the transceiver does not have an integrated pull-up, an external resistor should be placed between RXD and the regulated voltage supply for the microprocessor.
- **Pins 2, 5, 8 and 11 (EN1/2/3/4):** EN is an input pin that is used to place the device in a low power sleep mode. If this feature is not used the pin should be pulled high to the regulated voltage supply of the microprocessor through a series resistor, values between 1 k Ω and 10 k Ω . Additionally, a series resistor may be placed on the pin to limit current on the digital lines in the case of an over voltage fault.
- **Pin 13, 18, 23 and 24 (NC):** Not Connected
- **Pins 3, 6, 9 and 12 (TXD1/2/3/4):** The TXD pins are the transmitter input signals to the device from the microprocessor. A series resistor can be placed to limit the input current to the device in the case of an overvoltage on this pin. A capacitor to ground can be placed close to the input pin of the device to filter noise.
- **Pin 14, 19 (GND2/1):** This is the ground connection for the device. This pin should be tied to the ground plane through a short trace with the use of two vias to limit total return inductance.
- **Pins 22, 20, 17 and 15 (LIN1/2/3/4):** This pin connects to the LIN bus. For responder node applications a 220 pF capacitor to ground is implemented. For commander node applications and additional series resistor and blocking diode should be placed between the LIN pin and the $V_{SUP1/2}$ pin.
- **Pin 21, 160 ($V_{SUP1/2}$):** This is the supply pin for the device. A 100 nF decoupling capacitor should be placed as close to the device as possible.

Note

All ground and power connections should be made as short as possible and use at least two vias to minimize the total loop inductance.

10.4.2 Layout Example

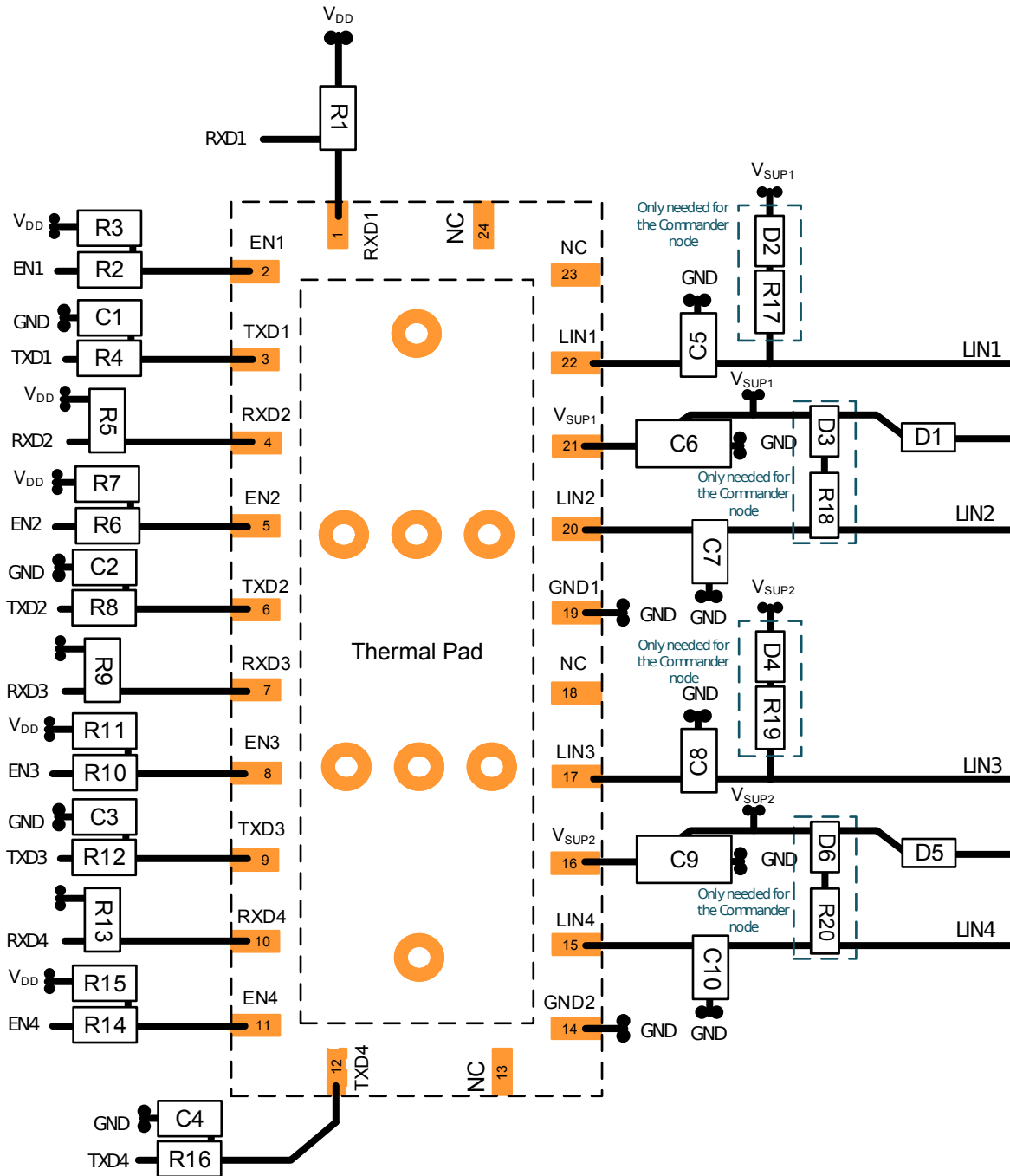

10-4. Layout Example

11 Device and Documentation Support

11.1 Documentation Support

This device will conform to the following LIN standards. The core of what is needed is covered within this system spec, however reference should be made to these standards and any discrepancies pointed out and discussed. This document should provide all the basics of what is needed.

11.1.1 Related Documentation

For related documentation see the following:

LIN Standards:

- ISO/DIS 17987-1: Road vehicles -- Local Interconnect Network (LIN) -- Part 1: General information and use case definition
- ISO/DIS 17987-4: Road vehicles -- Local Interconnect Network (LIN) -- Part 4: Electrical Physical Layer (EPL) specification 12V/24V
- SAE J2602-1: LIN Network for Vehicle Applications

EMC requirements:

- SAE J2962-1
- ISO 10605: Road vehicles - Test methods for electrical disturbances from electrostatic discharge
- ISO 11452-4:2011: Road vehicles - Component test methods for electrical disturbances from narrowband radiated electromagnetic energy - Part 4: Harness excitation methods
- ISO 7637-1:2015: Road vehicles - Electrical disturbances from conduction and coupling - Part 1: Definitions and general considerations
- ISO 7637-3: Road vehicles - Electrical disturbances from conduction and coupling - Part 3: Electrical transient transmission by capacitive and inductive coupling via lines other than supply lines
- IEC 62132-4:2006: Integrated circuits - Measurement of electromagnetic immunity 150 kHz to 1 GHz - Part 4: Direct RF power injection method
- IEC 6100-4-2
- IEC 61967-4
- CISPR25

Conformance Test requirements:

- ISO/DIS 17987-7: Road vehicles -- Local Interconnect Network (LIN) -- Part 7: Electrical Physical Layer (EPL) conformance test specification
- SAE J2602-2: LIN Network for Vehicle Applications Conformance Test

11.2 Receiving Notification of Documentation Updates

To receive notification of documentation updates, navigate to the device product folder on [ti.com](https://www.ti.com). Click on *Subscribe to updates* to register and receive a weekly digest of any product information that has changed. For change details, review the revision history included in any revised document.

11.3 サポート・リソース

TI E2E™ サポート・フォーラムは、エンジニアが検証済みの回答と設計に関するヒントをエキスパートから迅速かつ直接得ることができる場所です。既存の回答を検索したり、独自の質問をしたりすることで、設計に必要な支援を迅速に得ることができます。

リンクされているコンテンツは、該当する貢献者により、現状のまま提供されるものです。これらは TI の仕様を構成するものではなく、必ずしも TI の見解を反映したものではありません。TI の [使用条件](#) を参照してください。

11.4 Trademarks

TI E2E™ is a trademark of Texas Instruments.

すべての商標は、それぞれの所有者に帰属します。

11.5 Glossary

[TI Glossary](#) This glossary lists and explains terms, acronyms, and definitions.

12 Mechanical, Packaging, and Orderable Information

The following pages include mechanical, packaging, and orderable information. This information is the most current data available for the designated devices. This data is subject to change without notice and revision of this document. For browser-based versions of this data sheet, refer to the left-hand navigation.

PACKAGING INFORMATION

| Orderable part number | Status (1) | Material type (2) | Package Pins | Package qty Carrier | RoHS (3) | Lead finish/ Ball material (4) | MSL rating/ Peak reflow (5) | Op temp (°C) | Part marking (6) |
|---------------------------------|---------------|----------------------|-----------------|-----------------------|-------------|--------------------------------------|-----------------------------------|--------------|---------------------|
| TLIN2024ARGYRQ1 | Active | Production | VQFN (RGY) 24 | 3000 LARGE T&R | Yes | NIPDAU | Level-2-260C-1 YEAR | -40 to 125 | TL2024A |
| TLIN2024ARGYRQ1.A | Active | Production | VQFN (RGY) 24 | 3000 LARGE T&R | Yes | NIPDAU | Level-2-260C-1 YEAR | -40 to 125 | TL2024A |

(1) **Status:** For more details on status, see our [product life cycle](#).

(2) **Material type:** When designated, preproduction parts are prototypes/experimental devices, and are not yet approved or released for full production. Testing and final process, including without limitation quality assurance, reliability performance testing, and/or process qualification, may not yet be complete, and this item is subject to further changes or possible discontinuation. If available for ordering, purchases will be subject to an additional waiver at checkout, and are intended for early internal evaluation purposes only. These items are sold without warranties of any kind.

(3) **RoHS values:** Yes, No, RoHS Exempt. See the [TI RoHS Statement](#) for additional information and value definition.

(4) **Lead finish/Ball material:** Parts may have multiple material finish options. Finish options are separated by a vertical ruled line. Lead finish/Ball material values may wrap to two lines if the finish value exceeds the maximum column width.

(5) **MSL rating/Peak reflow:** The moisture sensitivity level ratings and peak solder (reflow) temperatures. In the event that a part has multiple moisture sensitivity ratings, only the lowest level per JEDEC standards is shown. Refer to the shipping label for the actual reflow temperature that will be used to mount the part to the printed circuit board.

(6) **Part marking:** There may be an additional marking, which relates to the logo, the lot trace code information, or the environmental category of the part.

Multiple part markings will be inside parentheses. Only one part marking contained in parentheses and separated by a "~" will appear on a part. If a line is indented then it is a continuation of the previous line and the two combined represent the entire part marking for that device.

Important Information and Disclaimer:The information provided on this page represents TI's knowledge and belief as of the date that it is provided. TI bases its knowledge and belief on information provided by third parties, and makes no representation or warranty as to the accuracy of such information. Efforts are underway to better integrate information from third parties. TI has taken and continues to take reasonable steps to provide representative and accurate information but may not have conducted destructive testing or chemical analysis on incoming materials and chemicals. TI and TI suppliers consider certain information to be proprietary, and thus CAS numbers and other limited information may not be available for release.

In no event shall TI's liability arising out of such information exceed the total purchase price of the TI part(s) at issue in this document sold by TI to Customer on an annual basis.

GENERIC PACKAGE VIEW

RGY 24

VQFN - 1 mm max height

5.5 x 3.5 mm, 0.5 mm pitch

PLASTIC QUAD FLATPACK - NO LEAD

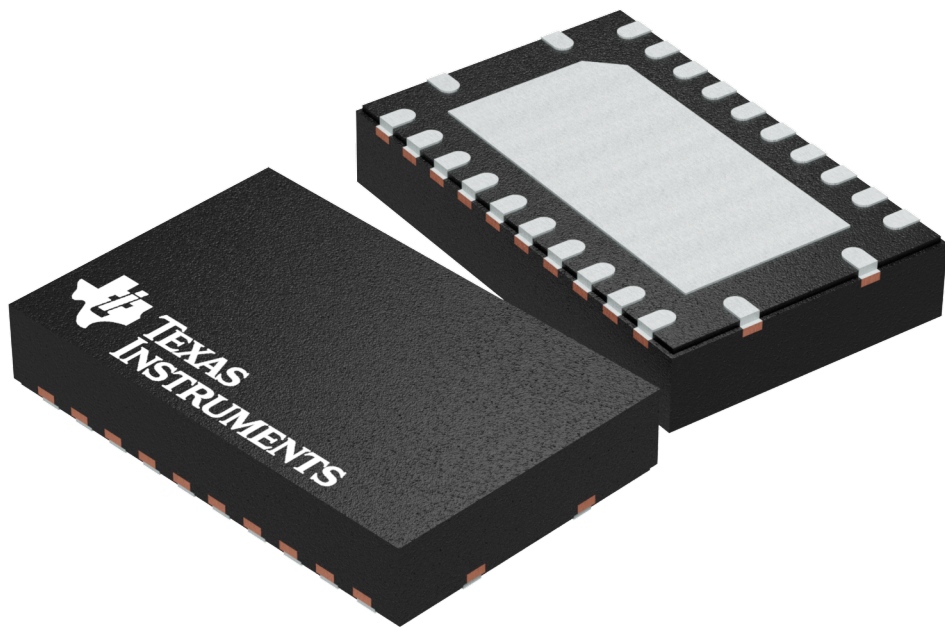

Images above are just a representation of the package family, actual package may vary.
Refer to the product data sheet for package details.

4203539-5/J

EXAMPLE STENCIL DESIGN

RGY0024E

VQFN - 1 mm max height

PLASTIC QUAD FLATPACK-NO LEAD

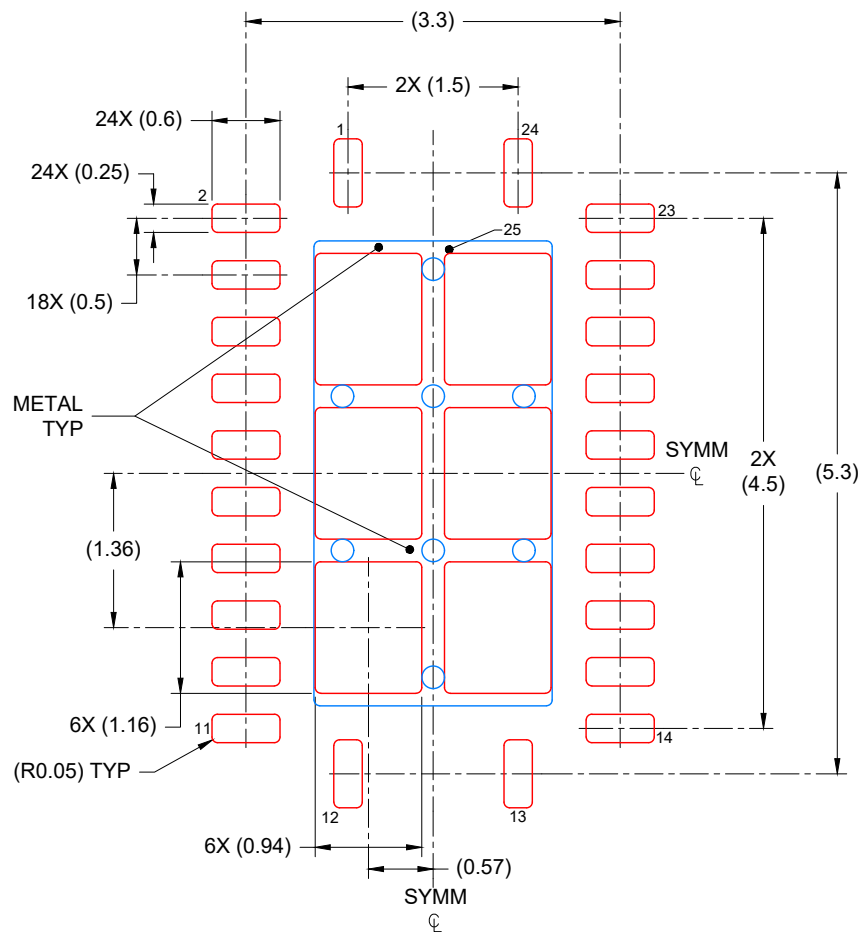

SOLDER PASTE EXAMPLE
BASED ON 0.125 mm THICK STENCIL

EXPOSED PAD
76% PRINTED COVERAGE BY AREA
SCALE: 15X

4225182/A 08/2019

NOTES: (continued)

6. Laser cutting apertures with trapezoidal walls and rounded corners may offer better paste release. IPC-7525 may have alternate design recommendations.

重要なお知らせと免責事項

TI は、技術データと信頼性データ(データシートを含みます)、設計リソース(リファレンス デザインを含みます)、アプリケーションや設計に関する各種アドバイス、Web ツール、安全性情報、その他のリソースを、欠陥が存在する可能性のある「現状のまま」提供しており、商品性および特定目的に対する適合性の黙示保証、第三者の知的財産権の非侵害保証を含むいかなる保証も、明示的または黙示的にかかわらず拒否します。

これらのリソースは、TI 製品を使用する設計の経験を積んだ開発者への提供を意図したものです。(1) お客様のアプリケーションに適した TI 製品の選定、(2) お客様のアプリケーションの設計、検証、試験、(3) お客様のアプリケーションに該当する各種規格や、その他のあらゆる安全性、セキュリティ、規制、または他の要件への確実な適合に関する責任を、お客様のみが単独で負うものとし、

上記の各種リソースは、予告なく変更される可能性があります。これらのリソースは、リソースで説明されている TI 製品を使用するアプリケーションの開発の目的でのみ、TI はその使用をお客様に許諾します。これらのリソースに関して、他の目的で複製することや掲載することは禁止されています。TI や第三者の知的財産権のライセンスが付与されている訳ではありません。お客様は、これらのリソースを自身で使用した結果発生するあらゆる申し立て、損害、費用、損失、責任について、TI およびその代理人を完全に補償するものとし、TI は一切の責任を拒否します。

TI の製品は、[TI の販売条件](#)、[TI の総合的な品質ガイドライン](#)、[ti.com](#) または TI 製品などに関連して提供される他の適用条件に従い提供されます。TI がこれらのリソースを提供することは、適用される TI の保証または他の保証の放棄の拡大や変更を意味するものではありません。TI がカスタム、またはカスタマー仕様として明示的に指定していない限り、TI の製品は標準的なカタログに掲載される汎用機器です。

お客様がいかなる追加条項または代替条項を提案する場合も、TI はそれらに異議を唱え、拒否します。

Copyright © 2026, Texas Instruments Incorporated

最終更新日 : 2025 年 10 月