

TMP300 1.8V 動作、抵抗でプログラム可能な温度スイッチ SC70 で供給されるアナログ出力温度センサ

1 特長

- 精度: $\pm 1^\circ\text{C}$ (標準 $+25^\circ\text{C}$)
- プログラム可能なトリップ・ポイント
- プログラム可能なヒステリシス 5°C もしくは 10°C
- オープン・ドレイン出力
- 低消費電力: $110\mu\text{A}$ 以下
- 広い電圧範囲: $+1.8\text{V}\sim+18\text{V}$
- 温度範囲: $-40^\circ\text{C}\sim+125^\circ\text{C}$
- アナログ出力: $10\text{mV}/^\circ\text{C}$
- SC70-6 および SOT23-6 パッケージ

2 アプリケーション

- 電源システム
- DC-DC モジュール
- 温度監視
- 電子保護システム

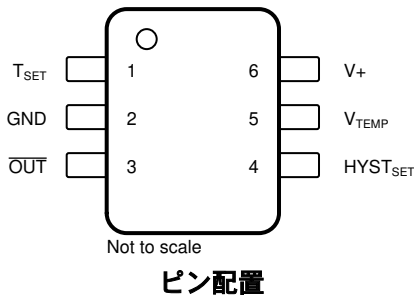

3 概要

TMP300 は低消費電力のデジタル出力温度スイッチで、抵抗によるプログラムが可能です。このデバイスは、外付け抵抗を追加することでスレッシュホールド・ポイントを設定できます。ヒステリシスを 2 つのレベルから選択できます。TMP300 は、テスト・ポイントとして、または温度補償ループ内で使用できる、アナログ出力 (V_{TEMP}) を備えています。

TMP300 は、熱特性が実証済みで、最低 1.8V の電源電圧により低消費電力で動作し、2 種類のマイクロパッケージで供給され、シンプルで信頼性の高い熱管理が必要とされる、消費電力の制約が厳しいシステム用に設計されています。

パッケージ情報 (1)

部品番号	パッケージ	本体サイズ (公称)
TMP300	SOT-23 (6)	2.90mm × 1.60mm
	SC70 (6)	2.00mm × 1.25mm

- (1) 利用可能なパッケージについては、このデータシートの末尾にある注文情報を参照してください。

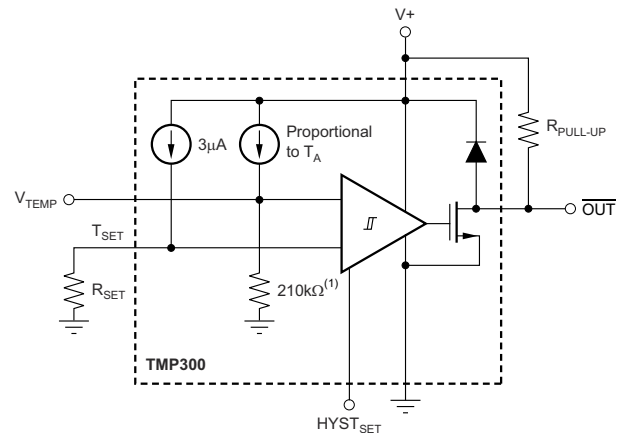

注: 約 10% 精度の薄膜抵抗。ただし、この精度誤差は工場出荷時に調整されます。

アプリケーション回路図



Table of Contents

1 特長	1	7 Detailed Description	8
2 アプリケーション	1	7.1 Overview.....	8
3 概要	1	7.2 Feature Description.....	8
4 Revision History	2	8 Device and Documentation Support	12
5 Pin Configuration and Functions	3	8.1 ドキュメントの更新通知を受け取る方法.....	12
6 Specifications	4	8.2 サポート・リソース.....	12
6.1 Absolute Maximum Ratings.....	4	8.3 Trademarks.....	12
6.2 ESD Ratings.....	4	8.4 静電気放電に関する注意事項.....	12
6.3 Electrical Characteristics.....	5	8.5 用語集.....	12
6.4 Typical Characteristics.....	6	9 Mechanical, Packaging, and Orderable Information..	12

4 Revision History

Changes from Revision E (December 2018) to Revision F (January 2023)	Page
• 文書全体にわたって表、図、相互参照の採番方法を更新.....	1
• 「製品情報」表を「パッケージ情報」に変更.....	1
• Added parameter to the <i>Absolute Maximum Ratings</i> table: input current into any pin.....	4
Changes from Revision D (January 2016) to Revision E (December 2018)	Page
• Added <i>Pin Configuration and Functions</i> section.....	3
Changes from Revision C (January 2011) to Revision D (January 2016)	Page
• 「製品情報」表、「ESD 定格」表、「機能説明」セクション、「デバイスおよびドキュメントのサポート」セクション、「メカニカル、パッケージ、および注文情報」セクションを追加.....	1
• 「温度範囲」で特徴の箇条書き項目を変更.....	1
• ピン配置にパッケージ名を追加.....	1
• Deleted <i>Ordering Information</i> table.....	4
• Changed Temperature Range, <i>TA</i> , <i>Functional Range</i> parameter name in <i>Electrical Characteristics</i> table.....	5
• Added footnote 4 to <i>Electrical Characteristics</i> table.....	5
Changes from Revision B (November 2008) to Revision C (January 2011)	Page
• 「概要」セクションから 2 番目の文を削除.....	1
• Added TMP300B grade device specifications to <i>Electrical Characteristics</i> table.....	5

5 Pin Configuration and Functions



图 5-1. DCK and DBV Package 6-Pin SOT-23 and SC70 Top View

表 5-1. Pin Functions

PIN		I/O	DESCRIPTION
NAME	NO.		
T _{SET}	1	I	Temperature set pin. Connects to a resistor to set the trip point
GND	2	—	Ground
OUT	3	O	Trip output
HYST _{SET}	4	I	Hysteresis Set. Connect to Ground for 5°C hysteresis or connect to V+ for 10°C hysteresis
V _{TEMP}	5	I	Analog Temperature output
V+	6	O	Supply voltage: 1.8 V to 18 V

6 Specifications

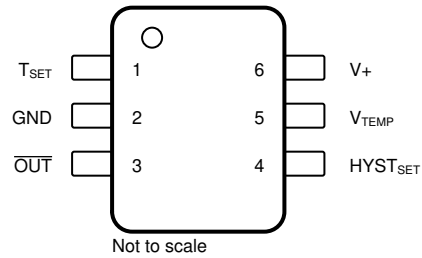
6.1 Absolute Maximum Ratings

over operating free-air temperature range (unless otherwise noted)⁽¹⁾

		MIN	MAX	UNIT
V+	Supply voltage		+18	V
	Signal input pins, voltage ⁽²⁾	-0.5	(V+) + 0.5	V
	Signal input pins, current ⁽²⁾	-10	10	mA
	Input current into any pin		10	mA
I _{SC}	Output short-circuit ⁽³⁾	Continuous		
	Open-drain output		(V+) + 0.5	V
T _A	Functional temperature	-40	+150	°C
T _{stg}	Storage temperature	-55	+150	°C
T _J	Junction temperature		+150	°C

- (1) Stresses beyond those listed under *Absolute Maximum Ratings* may cause permanent damage to the device. These are stress ratings only, which do not imply functional operation of the device at these or any other conditions beyond those indicated under *Recommended Operating Conditions*. Exposure to absolute-maximum-rated conditions for extended periods may affect device reliability.
- (2) Input pins are diode-clamped to the power-supply rails. Input signals that can swing more than 0.5V beyond the supply rails should be current limited to 10mA or less.
- (3) Short-circuit to ground.

6.2 ESD Ratings

		VALUE	UNIT
V _(ESD)	Electrostatic discharge	Human-body model (HBM)	±4000
		Charged-device model (CDM)	±1000

6.3 Electrical Characteristics

At $V_S = 3.3\text{ V}$ and $T_A = -40^\circ\text{C}$ to $+125^\circ\text{C}$, unless otherwise noted.

PARAMETER	TEST CONDITIONS	TMP300			TMP300B			UNIT	
		MIN ⁽¹⁾	TYP ⁽¹⁾	MAX ⁽¹⁾	MIN	TYP	MAX		
TEMPERATURE MEASUREMENT									
Measurement range	$V_S = 2.35\text{ V to }18\text{ V}$	-40		+125	-40		+125	°C	
	$V_S = 1.8\text{ V to }2.35\text{ V}$	-40		$100 \times (V_S - 0.95)$	-40		$100 \times (V_S - 0.95)$		
TRIP POINT									
Total accuracy	$T_A = -40^\circ\text{C to }+125^\circ\text{C}$		± 2	± 4 ⁽³⁾		± 2	± 6	°C	
R _{SET} equation	T_C is in °C		$R_{SET} = 10(50 + T_C)/3$			$R_{SET} = 10(50 + T_C)/3$			kΩ
HYSTERESIS SET INPUT									
LOW threshold				0.4			0.4	V	
HIGH threshold		$V_S - 0.4$			$V_S - 0.4$			V	
Threshold hysteresis	HYST _{SET} = GND			5			5	°C	
	HYST _{SET} = V_S			10			10		
DIGITAL OUTPUT									
Logic family			CMOS			CMOS			
Open-drain leakage current	OUT = V_S			10			10	μA	
V_{OL} Logic levels	$V_S = 1.8\text{ V to }18\text{ V}$, $I_{SINK} = 5\text{ mA}$			0.3			0.3	V	
ANALOG OUTPUT									
Accuracy			± 2	± 3		± 2	± 5	°C	
Temperature sensitivity			10			10		mV/°C	
Output voltage	$T_A = +25^\circ\text{C}$	720	750	780	720	750	780	mV	
V_{TEMP} pin output resistance			210			210		kΩ	
POWER SUPPLY									
I_Q Quiescent current ⁽²⁾	$V_S = 1.8\text{ V to }18\text{ V}$, $T_A = -40^\circ\text{C to }+125^\circ\text{C}$			110			110	μA	
TEMPERATURE RANGE									
T_A	Specified range	$V_S = 2.35\text{ V to }18\text{ V}$	-40		+125	-40		+125	°C
		$V_S = 1.8\text{ V to }2.35\text{ V}$	-40		$100 \times (V_S - 0.95)$	-40		$100 \times (V_S - 0.95)$	
	Functional range ⁽⁴⁾	$V_S = 2.35\text{ V to }18\text{ V}$	-40		+150	-40		+150	
		$V_S = 1.8\text{ V to }2.35\text{ V}$	-50		$100 \times (V_S - 0.95)$	-50		$100 \times (V_S - 0.95)$	
θ_{JA} Thermal resistance	SC70			250			250	°C/W	
	SOT23-6			180			180		

- (1) 100% of production is tested at $T_A = +85^\circ\text{C}$. Specifications over temperature range are ensured by design.
- (2) See [Figure 6-1](#) for typical quiescent current.
- (3) Shaded cells indicate characteristic performance difference.
- (4) The TMP300 is functional over this range and no indication of performance is implied.

6.4 Typical Characteristics

At $V_S = 5\text{ V}$, unless otherwise noted.

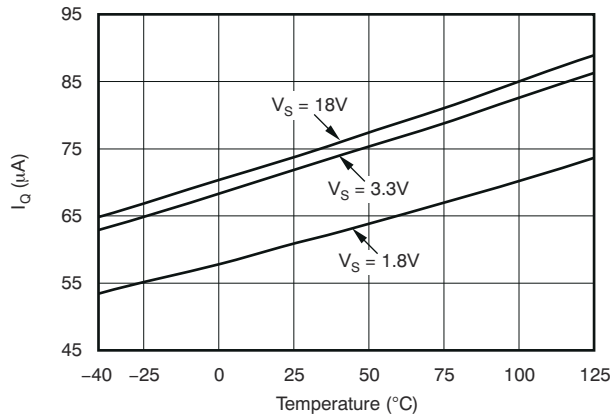

6-1. Quiescent Current Over Temperature and Supply

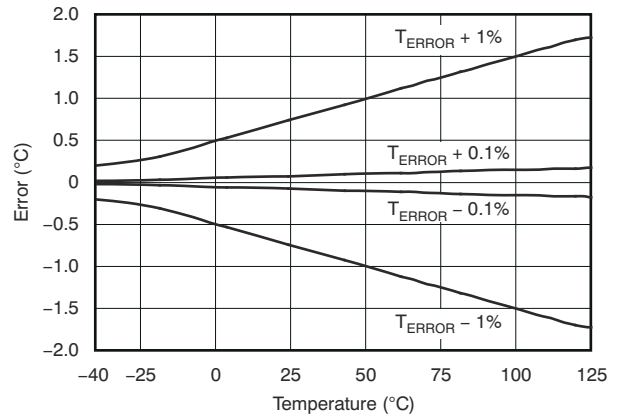

6-2. R_{SET} Shift Resulting From R_{SET} Tolerance

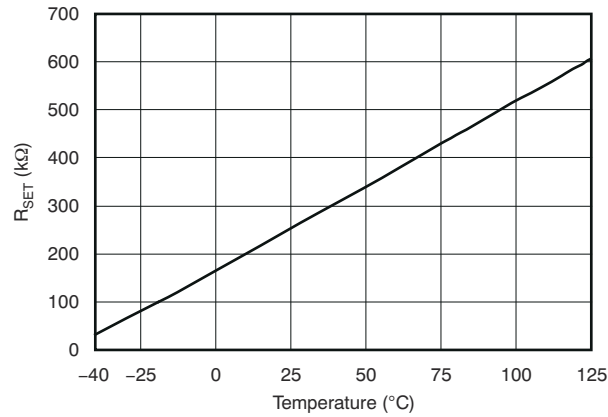

6-3. R_{SET} vs Temperature

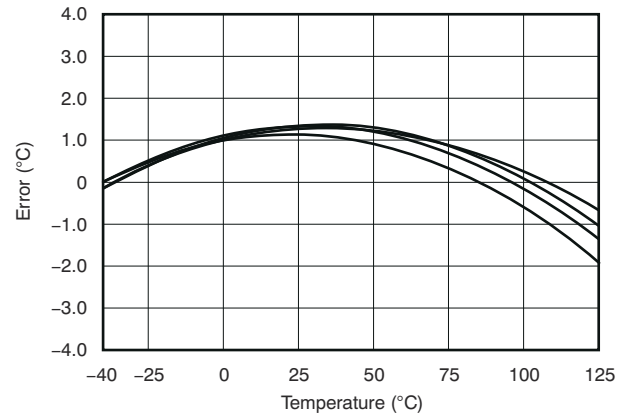

6-4. Typical Trip Error

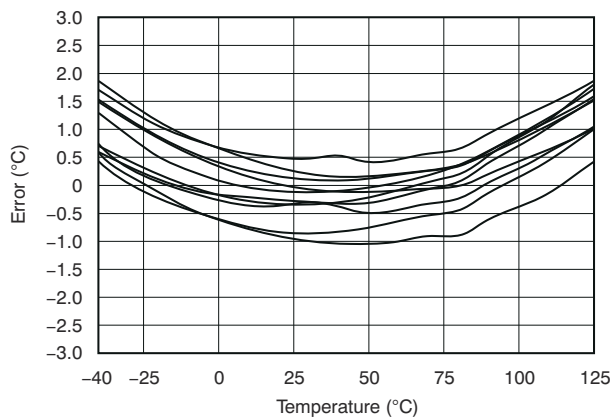

6-5. Typical Analog Output Error

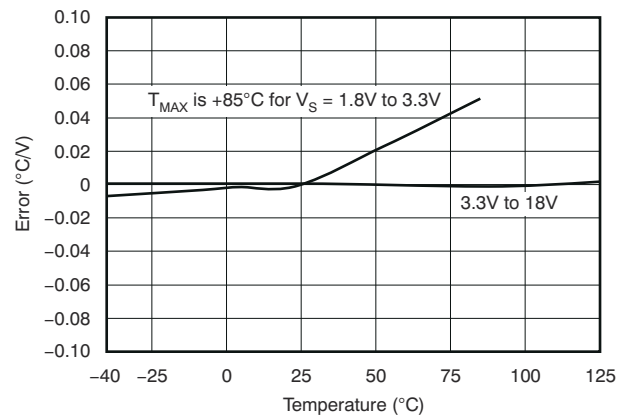

6-6. Analog PSR Over Temperature

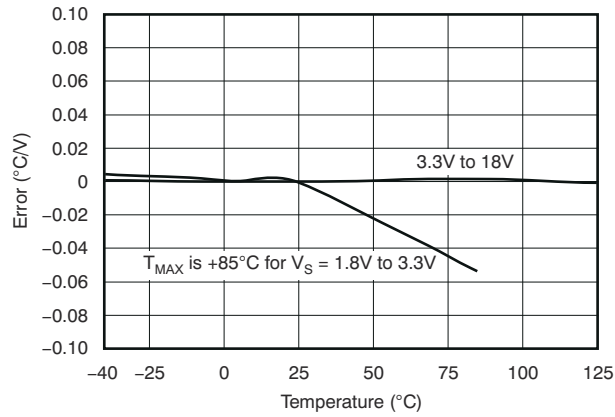

6-7. Trip PSR Over Temperature

7 Detailed Description

7.1 Overview

The TMP300 is a thermal sensor designed for overtemperature protection circuits in electronic systems. The TMP300 uses a set resistor to program the trip temperature of the digital output. An additional high-impedance (210 kΩ) analog voltage output provides the temperature reading.

7.2 Feature Description

7.2.1 Calculating R_{SET}

The set resistor (R_{SET}) provides a threshold voltage for the comparator input. The TMP300 trips when the V_{TEMP} pin exceeds the T_{SET} voltage. The value of the set resistor is determined by the analog output function and the 3-μA internal bias current.

To set the TMP300 to trip at a preset value, calculate the R_{SET} resistor value according to 式 1 or 式 2:

$$R_{SET} = \frac{(T_{SET} \times 0.01 + 0.5)}{3e^{-6}} \quad (1)$$

where

- T_{SET} is in °C; or

$$R_{SET} \text{ in } k\Omega = \frac{10(50 + T_{SET})}{3} \quad (2)$$

where

- T_{SET} is in °C.

7.2.2 Using V_{TEMP} to Trip the Digital Output

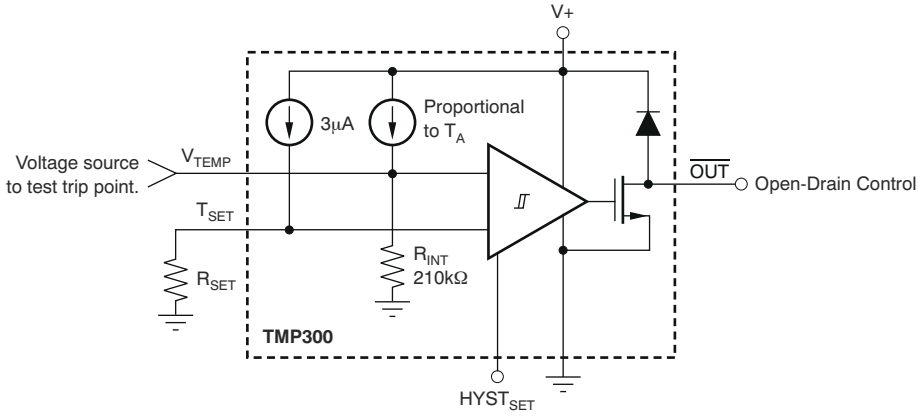
The analog voltage output can also serve as a voltage input that forces a trip of the digital output to simulate a thermal event. This simulation facilitates easy system design and test of thermal safety circuits, as shown in  7-1.

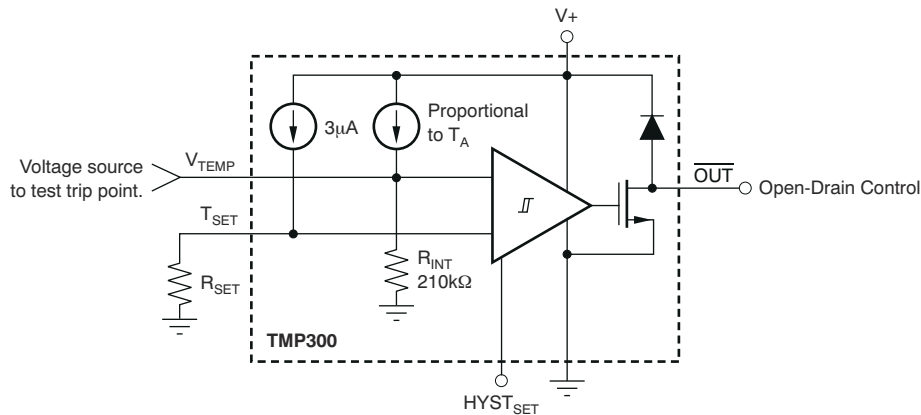

 7-1. Applying Voltage to Trip Digital Output

7.2.3 Analog Temperature Output

The analog out or V_{TEMP} pin is high-impedance (210 k Ω). Avoid loading this pin to prevent degrading the analog out value or trip point. Buffer the output of this pin when used for direct thermal measurement. [Fig 7-2](#) shows buffering of the analog output signal.

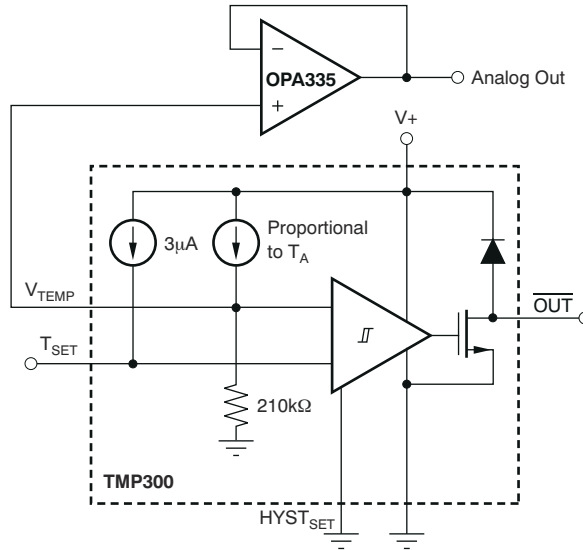

Fig 7-2. Buffering the Analog Output Signal

7.2.4 Using a DAC to Set the Trip Point

The trip point is easily converted by changing the digital-to-analog converter (DAC) code. This technique can be useful for control loops where a large thermal mass is being brought up to the set temperature and the \overline{OUT} pin is used to control the heating element. The analog output can be monitored in a control algorithm that adjusts the set temperature to prevent overshoot. [Fig 7-3](#) shows the trip set voltage error versus temperature, which shows error in $^{\circ}\text{C}$ of the comparator input over temperature. [Fig 7-4](#) shows an alternative method of setting the trip point by using a DAC.

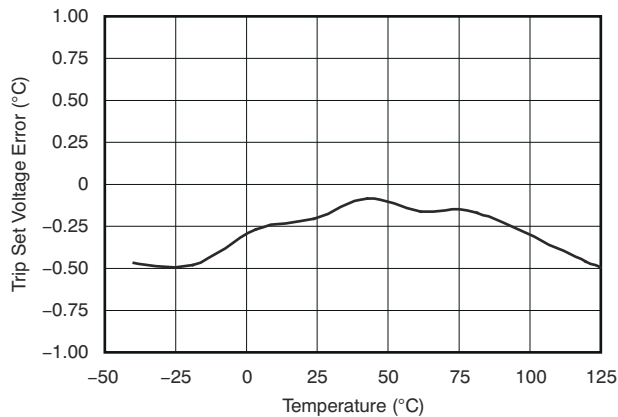

Fig 7-3. Trip Set Voltage Error vs Temperature

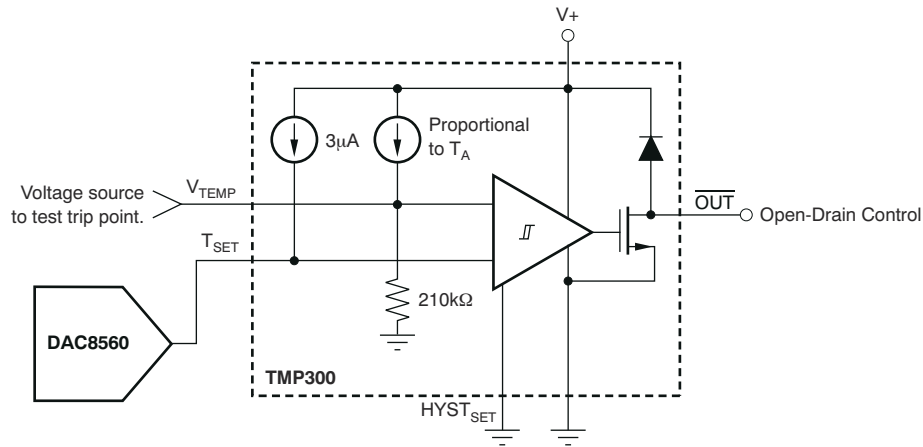
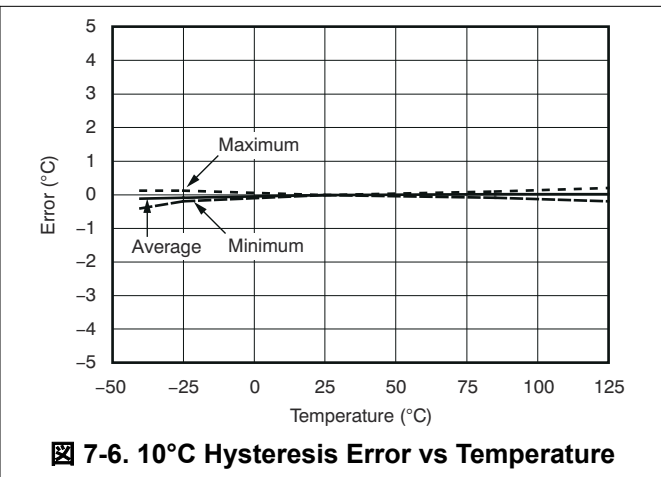
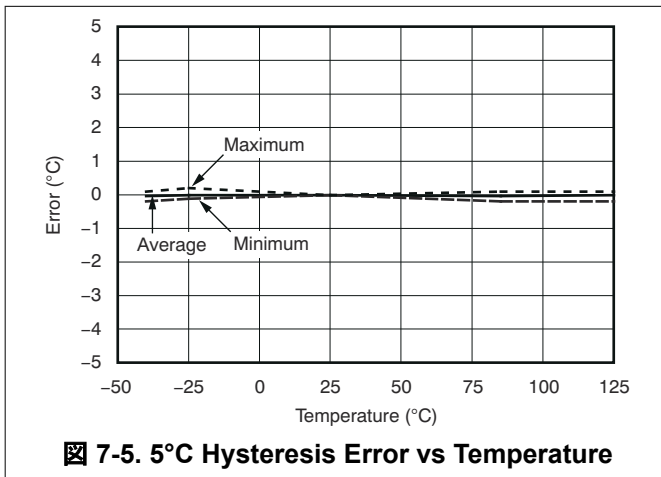

FIG 7-4. DAC Generates the Voltage-Driving T_{SET} Pin

7.2.5 Hysteresis

The hysteresis pin has two settings. Grounding HYST_{SET} results in 5°C of hysteresis. Connecting HYST_{SET} to V_S results in 10°C of hysteresis. FIG 7-5 and FIG 7-6 show the hysteresis error variation over temperature.



Use bypass capacitors on the supplies as well as on the R_{SET} and analog out (V_{TEMP}) pins when in noisy environments, as shown in [Figure 7-7](#). These capacitors reduce premature triggering of the comparator.

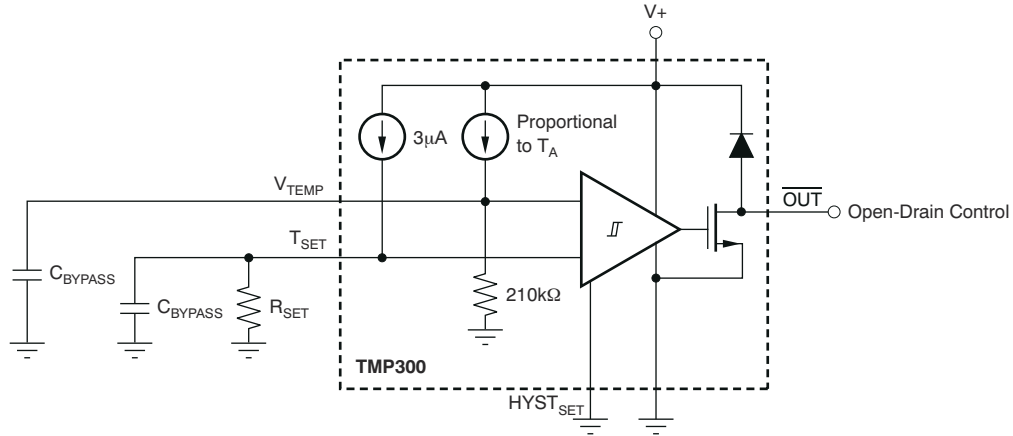

Figure 7-7. Bypass Capacitors Prevent Early Comparator Toggling Due to Circuit Board Noise

8 Device and Documentation Support

8.1 ドキュメントの更新通知を受け取る方法

ドキュメントの更新についての通知を受け取るには、[ti.com](https://www.ti.com) のデバイス製品フォルダを開いてください。「更新の通知を受け取る」をクリックして登録すると、変更されたすべての製品情報に関するダイジェストを毎週受け取れます。変更の詳細については、修正されたドキュメントに含まれている改訂履歴をご覧ください。

8.2 サポート・リソース

[TI E2E™ サポート・フォーラム](#)は、エンジニアが検証済みの回答と設計に関するヒントをエキスパートから迅速かつ直接得ることができる場所です。既存の回答を検索したり、独自の質問をしたりすることで、設計に必要な支援を迅速に得ることができます。

リンクされているコンテンツは、該当する貢献者により、現状のまま提供されるものです。これらは TI の仕様を構成するものではなく、必ずしも TI の見解を反映したものではありません。TI の[使用条件](#)を参照してください。

8.3 Trademarks

TI E2E™ is a trademark of Texas Instruments.

すべての商標は、それぞれの所有者に帰属します。

8.4 静電気放電に関する注意事項



この IC は、ESD によって破損する可能性があります。テキサス・インスツルメンツは、IC を取り扱う際には常に適切な注意を払うことを推奨します。正しい取り扱いおよび設置手順に従わない場合、デバイスを破損するおそれがあります。

ESD による破損は、わずかな性能低下からデバイスの完全な故障まで多岐にわたります。精密な IC の場合、パラメータがわずかに変化するだけで公表されている仕様から外れる可能性があるため、破損が発生しやすくなっています。

8.5 用語集

[テキサス・インスツルメンツ用語集](#) この用語集には、用語や略語の一覧および定義が記載されています。

9 Mechanical, Packaging, and Orderable Information

The following pages include mechanical, packaging, and orderable information. This information is the most current data available for the designated devices. This data is subject to change without notice and revision of this document. For browser-based versions of this data sheet, refer to the left-hand navigation.

PACKAGING INFORMATION

Orderable Device	Status (1)	Package Type	Package Drawing	Pins	Package Qty	Eco Plan (2)	Lead finish/ Ball material (6)	MSL Peak Temp (3)	Op Temp (°C)	Device Marking (4/5)	Samples
TMP300AIDBVR	NRND	SOT-23	DBV	6	3000	RoHS & Green	NIPDAU	Level-1-260C-UNLIM	-40 to 125	T300	
TMP300AIDCKR	NRND	SC70	DCK	6	3000	RoHS & Green	NIPDAU	Level-1-260C-UNLIM	-40 to 125	BPN	
TMP300BIDBVR	ACTIVE	SOT-23	DBV	6	3000	RoHS & Green	NIPDAU	Level-1-260C-UNLIM	-40 to 125	DUDC	Samples
TMP300BIDBVT	OBSOLETE	SOT-23	DBV	6		TBD	Call TI	Call TI	-40 to 125	DUDC	
TMP300BIDCKR	ACTIVE	SC70	DCK	6	3000	RoHS & Green	NIPDAU	Level-1-260C-UNLIM	-40 to 125	QWL	Samples
TMP300BIDCKT	OBSOLETE	SC70	DCK	6		TBD	Call TI	Call TI	-40 to 125	QWL	

(1) The marketing status values are defined as follows:

ACTIVE: Product device recommended for new designs.

LIFEBUY: TI has announced that the device will be discontinued, and a lifetime-buy period is in effect.

NRND: Not recommended for new designs. Device is in production to support existing customers, but TI does not recommend using this part in a new design.

PREVIEW: Device has been announced but is not in production. Samples may or may not be available.

OBSOLETE: TI has discontinued the production of the device.

(2) **RoHS:** TI defines "RoHS" to mean semiconductor products that are compliant with the current EU RoHS requirements for all 10 RoHS substances, including the requirement that RoHS substance do not exceed 0.1% by weight in homogeneous materials. Where designed to be soldered at high temperatures, "RoHS" products are suitable for use in specified lead-free processes. TI may reference these types of products as "Pb-Free".

RoHS Exempt: TI defines "RoHS Exempt" to mean products that contain lead but are compliant with EU RoHS pursuant to a specific EU RoHS exemption.

Green: TI defines "Green" to mean the content of Chlorine (Cl) and Bromine (Br) based flame retardants meet JS709B low halogen requirements of <=1000ppm threshold. Antimony trioxide based flame retardants must also meet the <=1000ppm threshold requirement.

(3) MSL, Peak Temp. - The Moisture Sensitivity Level rating according to the JEDEC industry standard classifications, and peak solder temperature.

(4) There may be additional marking, which relates to the logo, the lot trace code information, or the environmental category on the device.

(5) Multiple Device Markings will be inside parentheses. Only one Device Marking contained in parentheses and separated by a "~" will appear on a device. If a line is indented then it is a continuation of the previous line and the two combined represent the entire Device Marking for that device.

(6) Lead finish/Ball material - Orderable Devices may have multiple material finish options. Finish options are separated by a vertical ruled line. Lead finish/Ball material values may wrap to two lines if the finish value exceeds the maximum column width.

Important Information and Disclaimer:The information provided on this page represents TI's knowledge and belief as of the date that it is provided. TI bases its knowledge and belief on information provided by third parties, and makes no representation or warranty as to the accuracy of such information. Efforts are underway to better integrate information from third parties. TI has taken and

continues to take reasonable steps to provide representative and accurate information but may not have conducted destructive testing or chemical analysis on incoming materials and chemicals. TI and TI suppliers consider certain information to be proprietary, and thus CAS numbers and other limited information may not be available for release.

In no event shall TI's liability arising out of such information exceed the total purchase price of the TI part(s) at issue in this document sold by TI to Customer on an annual basis.

OTHER QUALIFIED VERSIONS OF TMP300 :

- Automotive : [TMP300-Q1](#)

NOTE: Qualified Version Definitions:

- Automotive - Q100 devices qualified for high-reliability automotive applications targeting zero defects

TAPE AND REEL INFORMATION

QUADRANT ASSIGNMENTS FOR PIN 1 ORIENTATION IN TAPE

*All dimensions are nominal

Device	Package Type	Package Drawing	Pins	SPQ	Reel Diameter (mm)	Reel Width W1 (mm)	A0 (mm)	B0 (mm)	K0 (mm)	P1 (mm)	W (mm)	Pin1 Quadrant
TMP300AIDBVR	SOT-23	DBV	6	3000	180.0	8.4	3.2	3.2	1.4	4.0	8.0	Q3
TMP300AIDCKR	SC70	DCK	6	3000	179.0	8.4	2.2	2.5	1.2	4.0	8.0	Q3
TMP300BIDBVR	SOT-23	DBV	6	3000	179.0	8.4	3.2	3.2	1.4	4.0	8.0	Q3
TMP300BIDCKR	SC70	DCK	6	3000	179.0	8.4	2.2	2.5	1.2	4.0	8.0	Q3

TAPE AND REEL BOX DIMENSIONS

*All dimensions are nominal

Device	Package Type	Package Drawing	Pins	SPQ	Length (mm)	Width (mm)	Height (mm)
TMP300AIDBVR	SOT-23	DBV	6	3000	200.0	183.0	25.0
TMP300AIDCKR	SC70	DCK	6	3000	200.0	183.0	25.0
TMP300BIDBVR	SOT-23	DBV	6	3000	200.0	183.0	25.0
TMP300BIDCKR	SC70	DCK	6	3000	200.0	183.0	25.0

DBV0006A



PACKAGE OUTLINE

SOT-23 - 1.45 mm max height

SMALL OUTLINE TRANSISTOR



4214840/G 08/2024

NOTES:

1. All linear dimensions are in millimeters. Any dimensions in parenthesis are for reference only. Dimensioning and tolerancing per ASME Y14.5M.
2. This drawing is subject to change without notice.
3. Body dimensions do not include mold flash or protrusion. Mold flash and protrusion shall not exceed 0.25 per side.
4. Leads 1,2,3 may be wider than leads 4,5,6 for package orientation.
5. Reference JEDEC MO-178.

EXAMPLE BOARD LAYOUT

DBV0006A

SOT-23 - 1.45 mm max height

SMALL OUTLINE TRANSISTOR



LAND PATTERN EXAMPLE
EXPOSED METAL SHOWN
SCALE:15X

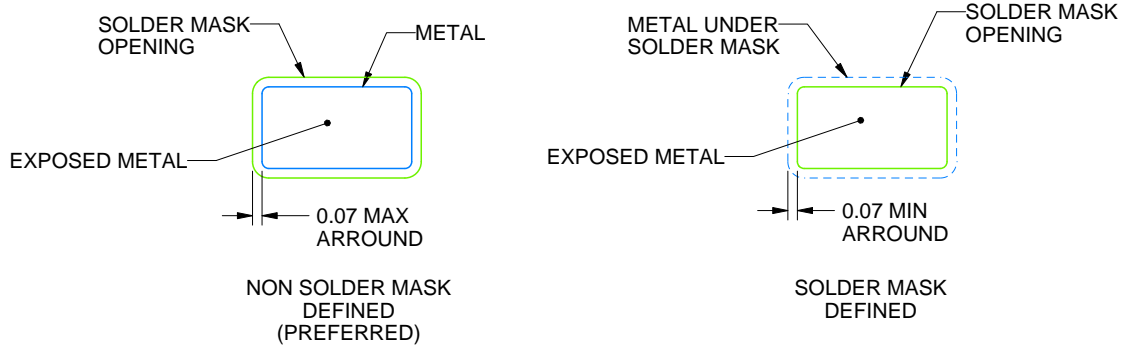

SOLDER MASK DETAILS

4214840/G 08/2024

NOTES: (continued)

6. Publication IPC-7351 may have alternate designs.
7. Solder mask tolerances between and around signal pads can vary based on board fabrication site.

EXAMPLE STENCIL DESIGN

DBV0006A

SOT-23 - 1.45 mm max height

SMALL OUTLINE TRANSISTOR



SOLDER PASTE EXAMPLE
BASED ON 0.125 mm THICK STENCIL
SCALE:15X

4214840/G 08/2024

NOTES: (continued)

8. Laser cutting apertures with trapezoidal walls and rounded corners may offer better paste release. IPC-7525 may have alternate design recommendations.
9. Board assembly site may have different recommendations for stencil design.

DCK0006A



PACKAGE OUTLINE

SOT - 1.1 max height

SMALL OUTLINE TRANSISTOR

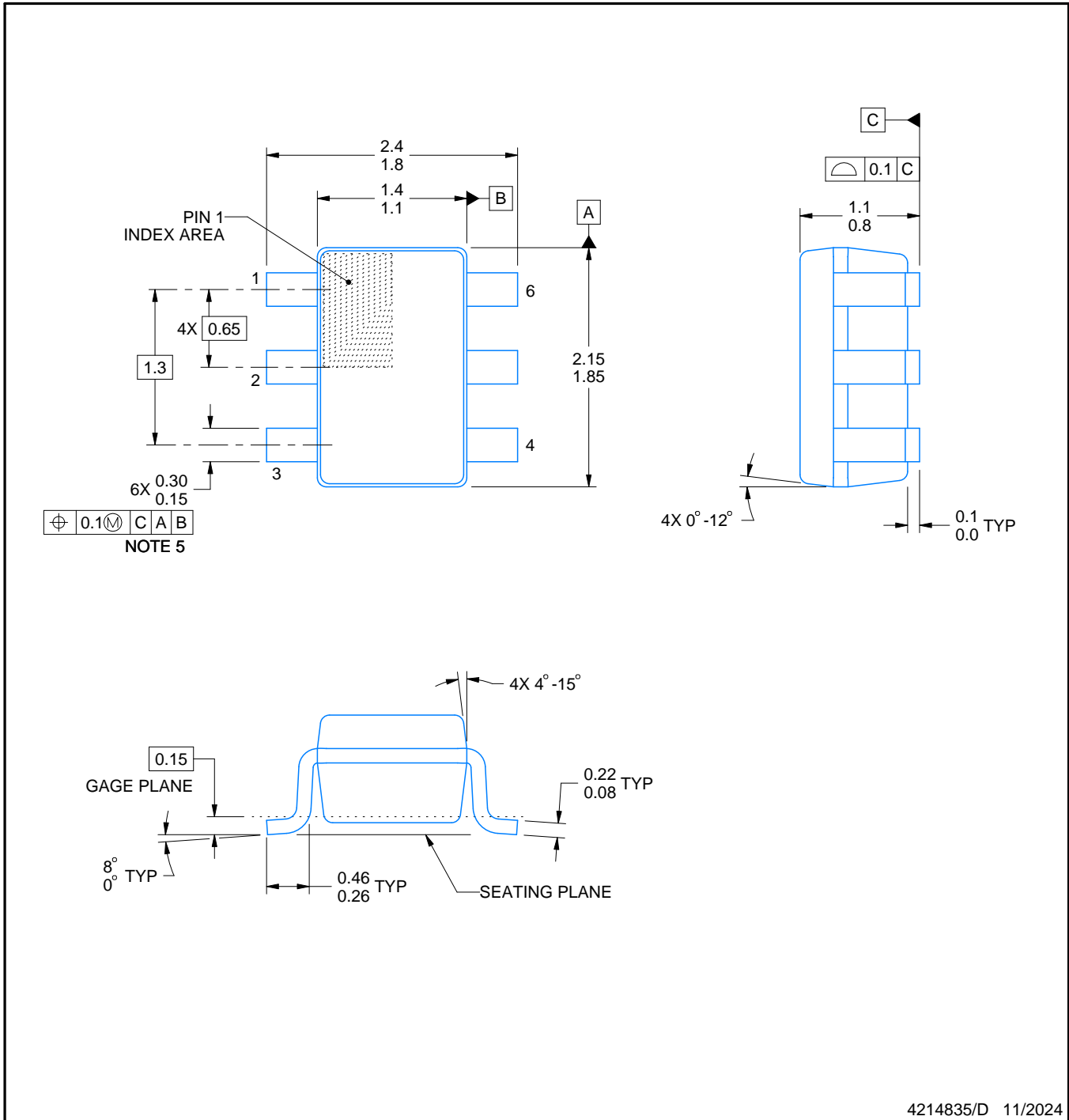

4214835/D 11/2024

NOTES:

1. All linear dimensions are in millimeters. Any dimensions in parenthesis are for reference only. Dimensioning and tolerancing per ASME Y14.5M.
2. This drawing is subject to change without notice.
3. Body dimensions do not include mold flash or protrusion. Mold flash and protrusion shall not exceed 0.15 per side.
4. Falls within JEDEC MO-203 variation AB.

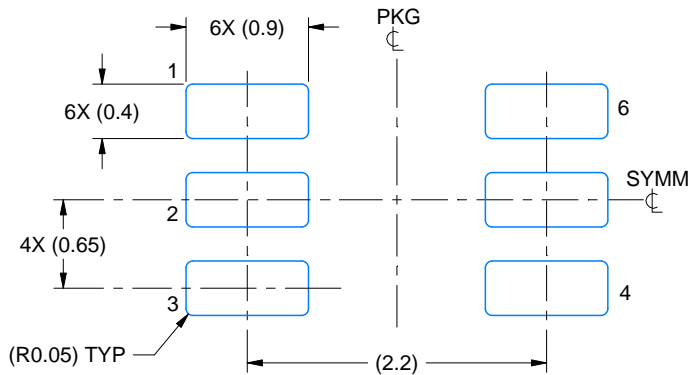

LAND PATTERN EXAMPLE
EXPOSED METAL SHOWN
SCALE:18X

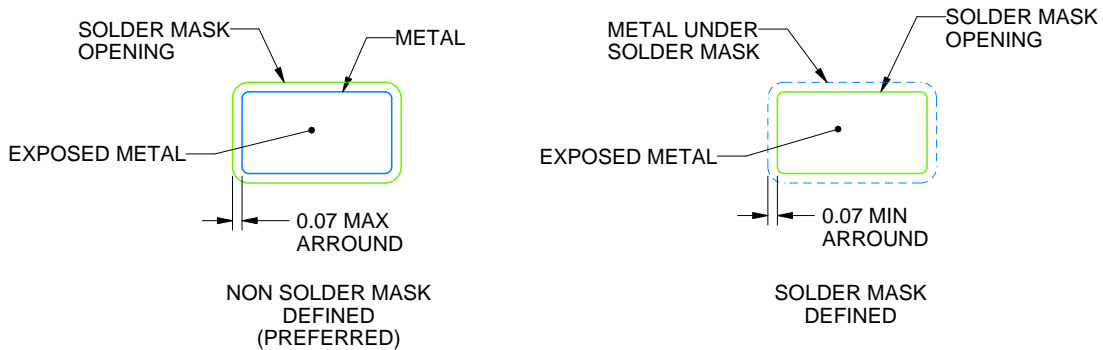

SOLDER MASK DETAILS

4214835/D 11/2024

NOTES: (continued)

- 5. Publication IPC-7351 may have alternate designs.
- 6. Solder mask tolerances between and around signal pads can vary based on board fabrication site.



SOLDER PASTE EXAMPLE
BASED ON 0.125 THICK STENCIL
SCALE:18X

4214835/D 11/2024

NOTES: (continued)

7. Laser cutting apertures with trapezoidal walls and rounded corners may offer better paste release. IPC-7525 may have alternate design recommendations.
8. Board assembly site may have different recommendations for stencil design.

重要なお知らせと免責事項

テキサス・インスツルメンツは、技術データと信頼性データ(データシートを含みます)、設計リソース(リファレンス デザインを含みます)、アプリケーションや設計に関する各種アドバイス、Web ツール、安全性情報、その他のリソースを、欠陥が存在する可能性のある「現状のまま」提供しており、商品性および特定目的に対する適合性の黙示保証、第三者の知的財産権の非侵害保証を含むいかなる保証も、明示的または黙示的にかかわらず拒否します。

これらのリソースは、テキサス・インスツルメンツ製品を使用する設計の経験を積んだ開発者への提供を意図したものです。(1) お客様のアプリケーションに適したテキサス・インスツルメンツ製品の選定、(2) お客様のアプリケーションの設計、検証、試験、(3) お客様のアプリケーションに該当する各種規格や、その他のあらゆる安全性、セキュリティ、規制、または他の要件への確実な適合に関する責任を、お客様のみが単独で負うものとし、ます。

上記の各種リソースは、予告なく変更される可能性があります。これらのリソースは、リソースで説明されているテキサス・インスツルメンツ製品を使用するアプリケーションの開発の目的でのみ、テキサス・インスツルメンツはその使用をお客様に許諾します。これらのリソースに関して、他の目的で複製することや掲載することは禁止されています。テキサス・インスツルメンツや第三者の知的財産権のライセンスが付与されている訳ではありません。お客様は、これらのリソースを自身で使用した結果発生するあらゆる申し立て、損害、費用、損失、責任について、テキサス・インスツルメンツおよびその代理人を完全に補償するものとし、テキサス・インスツルメンツは一切の責任を拒否します。

テキサス・インスツルメンツの製品は、[テキサス・インスツルメンツの販売条件](#)、または [ti.com](https://www.ti.com) やかかるテキサス・インスツルメンツ製品の関連資料などのいずれかを通じて提供する適用可能な条項の下で提供されています。テキサス・インスツルメンツがこれらのリソースを提供することは、適用されるテキサス・インスツルメンツの保証または他の保証の放棄の拡大や変更を意味するものではありません。

お客様がいかなる追加条項または代替条項を提案した場合でも、テキサス・インスツルメンツはそれらに異議を唱え、拒否します。

郵送先住所：Texas Instruments, Post Office Box 655303, Dallas, Texas 75265
Copyright © 2025, Texas Instruments Incorporated