

TPS61391 電流ミラーを内蔵した 85V_{OUT} の昇圧コンバータ

1 特長

- 入力電圧範囲: 2.5V~5.5V
- 出力電圧範囲: 85V (最大値)
- スイッチング FET の $R_{(DS)on}$: 0.9Ω
- スイッチ電流制限: 1000mA
- 応答時間 0.5μs の高光出力保護
- スイッチング周波数: 700kHz
- 静止電流: VIN から 110μA、VOUT から 340μA、AVCC から 140μA
- ソフト・スタート時間: 4.8ms
- パッケージ: 3mm × 3mm × 0.75mm QFN

2 アプリケーション

- APD のバイアス
- 光ライン端末
- 高電圧センサの電源

3 概要

TPS61391 は、2.5V~5.5V の入力に対応する 85V スイッチ FET を内蔵した 700kHz パルス幅変調 (PWM) 昇圧コンバータです。スイッチング・ピーク電流は最大 1000mA です。TPS61391 は高精度電流ミラーを内蔵しており、2 種類のゲイン (1:5 または 4:5) を選択できます。

また、TPS61391 は、APD の電力経路と直列に FET を追加することで、応答時間 0.5 μs (標準値) の高光出力保護機能も実現できます。この保護機能は、高光出力が解除されると自動的に復帰します。

TPS61391 は、底面に露出パッドを備えた 3mm × 3mm QFN パッケージで供給されます。

製品情報⁽¹⁾

型番	パッケージ	本体サイズ(公称)
TPS61391	WQFN (16)	3.00mm×3.00mm

(1) 提供されているすべてのパッケージについては、データシートの末尾にある注文情報を参照してください。

代表的なアプリケーション回路

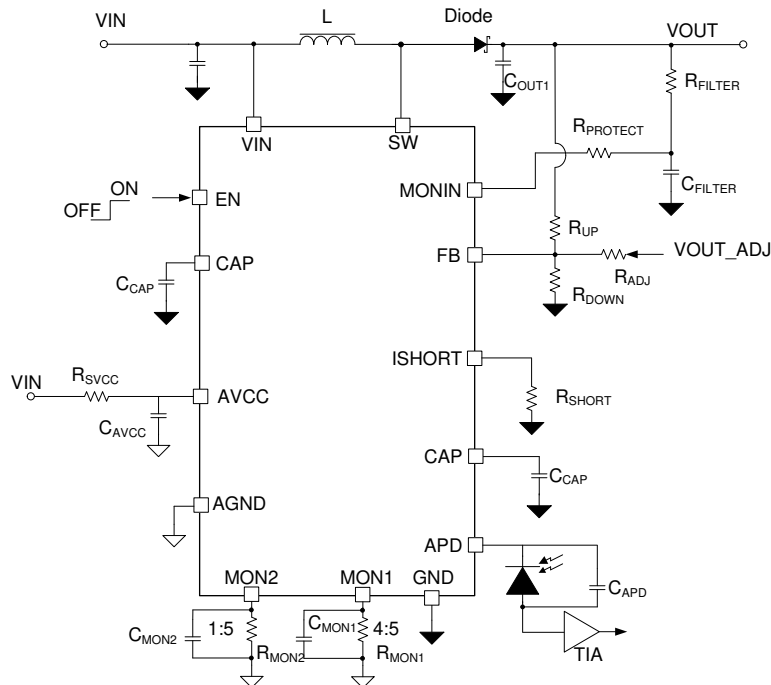

目次

1	特長	1	7.4	Device Functional Mode	10
2	アプリケーション	1	8	Application and Implementation	11
3	概要	1	8.1	Application Information	11
4	改訂履歴	2	8.2	Typical Application	11
5	Pin Configuration and Functions	3	9	Power Supply Recommendations	14
6	Specifications	4	10	Layout	15
6.1	Recommended Operating Conditions	4	10.1	Layout Guidelines	15
6.2	Absolute Maximum Ratings	4	10.2	Layout Example	16
6.3	ESD Ratings	4	11	デバイスおよびドキュメントのサポート	17
6.4	Thermal Information	4	11.1	ドキュメントのサポート	17
6.5	Electrical Characteristics	4	11.2	ドキュメントの更新通知を受け取る方法	17
6.6	Typical Characteristics	6	11.3	サポート・リソース	17
7	Detailed Description	8	11.4	商標	17
7.1	Overview	8	11.5	静電気放電に関する注意事項	17
7.2	Functional Block Diagram	9	11.6	Glossary	17
7.3	Feature Description	9	12	メカニカル、パッケージ、および注文情報	17

4 改訂履歴

日付	リビジョン	注
2019年11月	*	初版

5 Pin Configuration and Functions

**RTE Package
16-Pin WQFN
Top View**

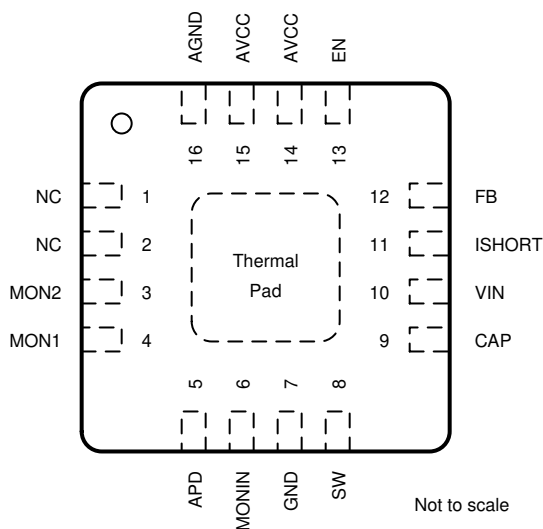

Pin Functions

PIN		I/O	DESCRIPTION
NAME	NO.		
NC	1,2	N/A	No internal connection
MON2	3	O	Current mirror output pin of 1 : 5 ratio (Mirror current: APD current)
MON1	4	O	Current mirror output pin of 4 : 5 ratio (Mirror current: APD current)
APD	5	O	Power supply for the APD, connect this pin with the cathode of APD
MONIN	6	I	Current mirror input pin
GND	7	–	Power Ground
SW	8	PWR	The switching node pin of the converter. It is connected to the drain of the internal low-side power MOSFET and the source of the internal high-side power MOSFET
CAP	9	O	Connecting a capacitor externally to lower the noise for current mirror.
VIN	10	I	IC power supply input
ISHORT	11	O	Programming the current limit for high optical power protection by a resistor between this pin and GND.
FB	12	I	Feedback voltage
EN	13	I	Enable logic input. Logic high level enables the device. Logic low level disables the device and turns it into shutdown mode
AVCC	14,15	I	Power supply for the current monitor circuitry
AGND	16	–	Analog ground for the current monitor circuitry
Exposed Thermal Pad			Connect with GND, TI recommends connecting to Power GND on PCB

6 Specifications

6.1 Recommended Operating Conditions

over operating free-air temperature range (unless otherwise noted)

		MIN	NOM	MAX	UNIT
V _{IN}	Input voltage	2.5		5.5	V
V _{OUT}	Output voltage	20		85	V
T _J	Junction temperature	−40		125	°C
L	Effective Inductance		4.7		μH
C _{IN}	Effective Input Capacitance		1		μF
C _{OUT}	Effective Output Capacitance		0.1		μF

6.2 Absolute Maximum Ratings

over operating free-air temperature range (unless otherwise noted)⁽¹⁾

		MIN	MAX	UNIT
Voltage	SW, APD, MONIN,CAP	−0.3	85	V
	Other pins	−0.3	6	V
T _J	Operating junction temperature	−40	125	°C
T _{stg}	Storage temperature	−65	150	°C

- (1) Stresses beyond those listed under *Absolute Maximum Rating* may cause permanent damage to the device. These are stress ratings only, which do not imply functional operation of the device at these or any other conditions beyond those indicated under *Recommended Operating Condition*. Exposure to absolute-maximum-rated conditions for extended periods may affect device reliability.

6.3 ESD Ratings

			VALUE	UNIT
V _(ESD)	Electrostatic discharge	Human body model (HBM), per ANSI/ESDA/JEDEC JS-001, allpins ⁽¹⁾	±1500	V
		Charged device model (CDM), per JEDEC specification JESD22-C101, all pins ⁽²⁾	±500	

- (1) JEDEC document JEP155 states that 500-V HBM allows safe manufacturing with a standard ESD control process.
 (2) JEDEC document JEP157 states that 250-V CDM allows safe manufacturing with a standard ESD control process.

6.4 Thermal Information

THERMAL METRIC ⁽¹⁾		TPS61391	UNIT
		RTE (WQFN)	
		16 PINS	
R _{θJA}	Junction-to-ambient thermal resistance	52.9	°C/W
R _{θJC(top)}	Junction-to-case (top) thermal resistance	54.4	°C/W
R _{θJB}	Junction-to-board thermal resistance	27.9	°C/W
Ψ _{JT}	Junction-to-top characterization parameter	2.0	°C/W
Y _{JB}	Junction-to-board characterization parameter	27.8	°C/W
R _{θJC(bot)}	Junction-to-case (bottom) thermal resistance	12.8	°C/W

- (1) For more information about traditional and new thermal metrics, see the [Semiconductor and IC Package Thermal Metrics](#) application report.

6.5 Electrical Characteristics

Over recommended free-air temperature range, V_{IN} = 3.3 V, AV_{CC} = 3.3 V, V_{MONIN} = 20 V to 85 V, T_J = - 40°C to 125°C, typical values are at T_A = 25°C (unless otherwise noted)

PARAMETER	TEST CONDITIONS	MIN	TYP	MAX	UNIT
POWER SUPPLY					
V _{IN}	Input voltage range	2.5		5.5	V

Electrical Characteristics (continued)

Over recommended free-air temperature range, $V_{IN} = 3.3\text{ V}$, $AV_{CC} = 3.3\text{ V}$, $V_{MONIN} = 20\text{ V}$ to 85 V , $T_J = -40^\circ\text{C}$ to 125°C , typical values are at $T_A = 25^\circ\text{C}$ (unless otherwise noted)

PARAMETER		TEST CONDITIONS	MIN	TYP	MAX	UNIT
V_{UVLO}	Under voltage lock out	V_{IN} falling		2.4	2.5	V
	Under voltage lock out hysteresis	V_{UVLO} rising - V_{UVLO} falling		200		mV
I_{Q_IN}	Quiescent current into VIN pin	$V_{IN} = 3.3\text{ V}$, $V_{FB} = V_{REF} + 0.1\text{ V}$, No switching, $-40^\circ\text{C} \leq T_J \leq 85^\circ\text{C}$		110	140	μA
I_{Q_OUT}	Quiescent current into VOUT pin	$V_{IN} = 3.3\text{ V}$, $V_{FB} = V_{REF} + 0.1\text{ V}$, No switching, $-40^\circ\text{C} \leq T_J \leq 85^\circ\text{C}$		340	430	μA
I_{Q_VCC}	Quiescent current into AVCC pin	$AV_{CC} = 3.3\text{ V}$ $-40^\circ\text{C} \leq T_J \leq 85^\circ\text{C}$		140	180	μA
I_{SD}	Shutdown current into VIN pin	$2.5\text{ V} \leq V_{IN} \leq 5.5\text{ V}$, $EN = 0$, $-40^\circ\text{C} \leq T_J \leq 85^\circ\text{C}$			1	μA
	Shutdown current into VOUT pin	$EN = 0$, $-40^\circ\text{C} \leq T_J \leq 85^\circ\text{C}$			1	μA
	Shutdown current into AVCC pin	$AV_{CC} = 3.3\text{ V}$, $EN = 0$, $-40^\circ\text{C} \leq T_J \leq 85^\circ\text{C}$			1	μA
OUTPUT						
V_{OUT}	Output voltage range				85	V
V_{REF}	Feedback regulation reference voltage	$V_{IN} = 2.5\text{ V}$ to 5.5 V , $T_J = 25^\circ\text{C}$	1.188	1.2	1.212	V
		$V_{IN} = 2.5\text{ V}$ to 5.5 V , $-40^\circ\text{C} \leq T_J \leq 125^\circ\text{C}$	1.182	1.2	1.218	V
I_{FB}	Feedback input leakage current		1	25		nA
POWER SWITCH						
$R_{DS(on)}$	Low-side FET on resistance	$3\text{ V} \leq V_{IN} \leq 5.5\text{ V}$		900	1300	m Ω
SWITCHING CHARACTERISTIC						
f_{SW}	Switching frequency	$V_{IN} = 3.3\text{ V}$, $V_{OUT} = 60\text{ V}$	600	700	800	kHz
CURRENT MIRROR						
k_{MON1}	4:5 Current mirror gain	$I_{APD} = 5\text{ }\mu\text{A}$ to $200\text{ }\mu\text{A}$	0.76	0.8	0.84	
k_{MON2}	1:5 Current mirror gain	$I_{APD} = 100\text{ }\mu\text{A}$ to 2 mA	0.19	0.2	0.21	
V_{MON}	MON1 / MON2 Threshold		380	400	420	mV
V_{APD_DRP}	Current mirror voltage drop	$I_{APD} = 1\text{ mA}$	2.2	2.5	2.8	V
		$I_{APD} = 5\text{ }\mu\text{A}$		2.45		V
I_{BIAS}	Current mirror bias current		15	20	25	μA
CURRENT LIMIT						
I_{LIM_SW}	Peak switching current limit	$V_{IN} = 3.3\text{ V}$, $V_{OUT} = 60\text{ V}$	800	1000	1200	mA
I_{SHORT}	High optical power current limit	$R_{ISHORT} = 25\text{ k}\Omega$	3.7	4	4.3	mA
		$R_{ISHORT} = 50\text{ k}\Omega$	1.8	2	2.2	mA
CONTROL (EN)						
V_{EN_H}	EN Logic high threshold				1.2	V
V_{EN_L}	EN Logic low threshold		0.4			V
R_{EN}	EN pull down resistor			800		k Ω
TIMING						
t_{SS}	Soft start time	Ref voltage 0 to 1.2V		4.8		ms
t_{DELAY}	Delay time for high optical power protection	$I_{APD} = 5\text{ mA}$, $I_{SHORT} = 3\text{ mA}$		0.5		μs
THERMAL PROTECTION						
T_{SD}	Thermal shutdown threshold	T_J rising		150		$^\circ\text{C}$
T_{SD_HYS}	Thermal shutdown hysteresis	T_J falling below T_{SD}		20		$^\circ\text{C}$

6.6 Typical Characteristics

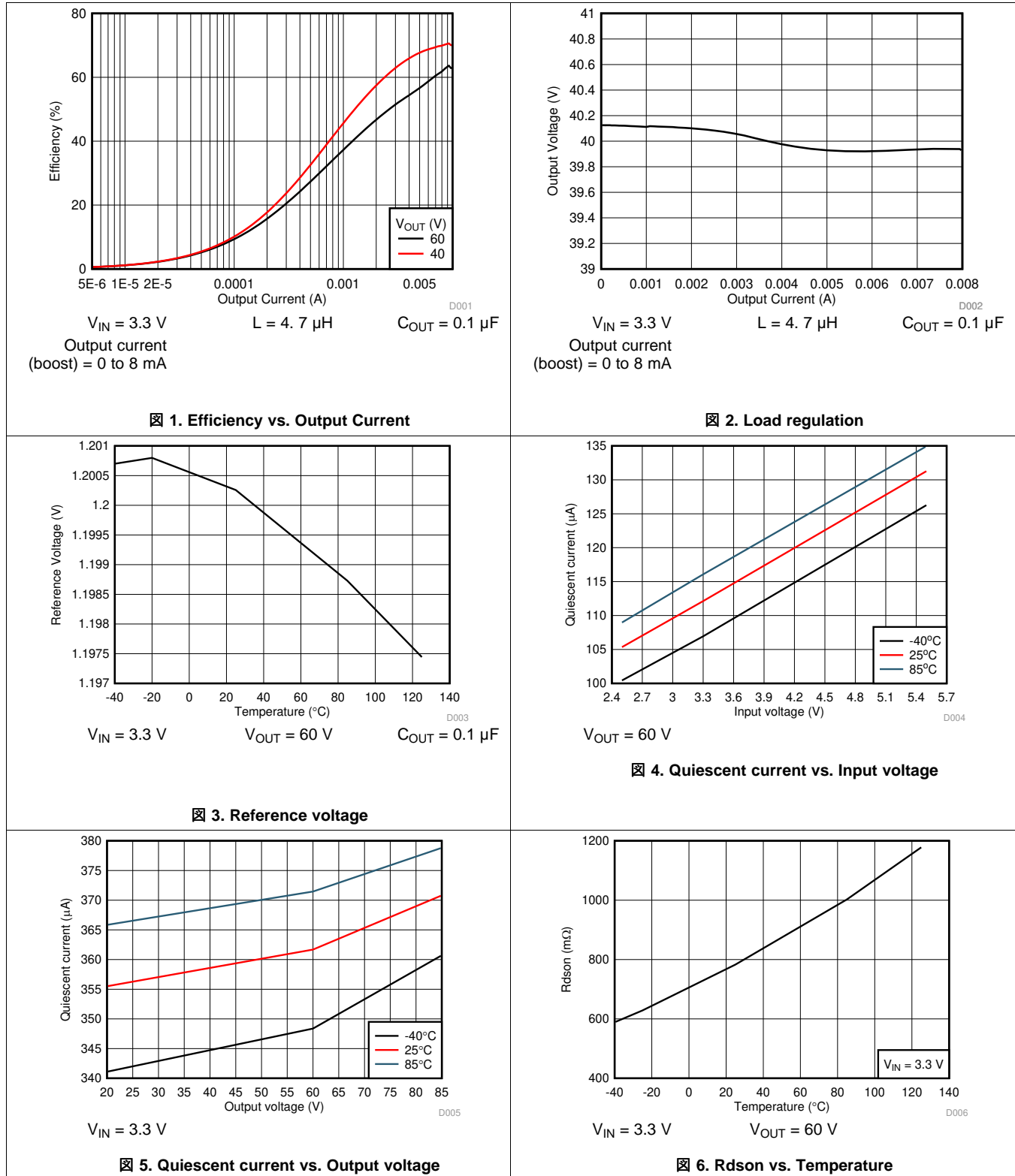

Typical Characteristics (continued)

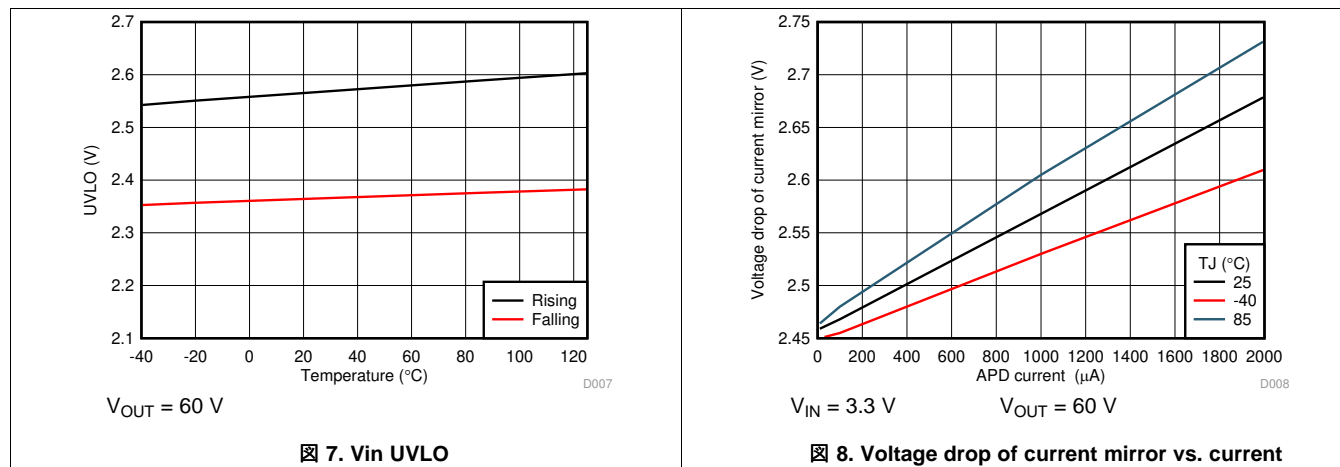

Figure 7. Vin UVLO

Figure 8. Voltage drop of current mirror vs. current

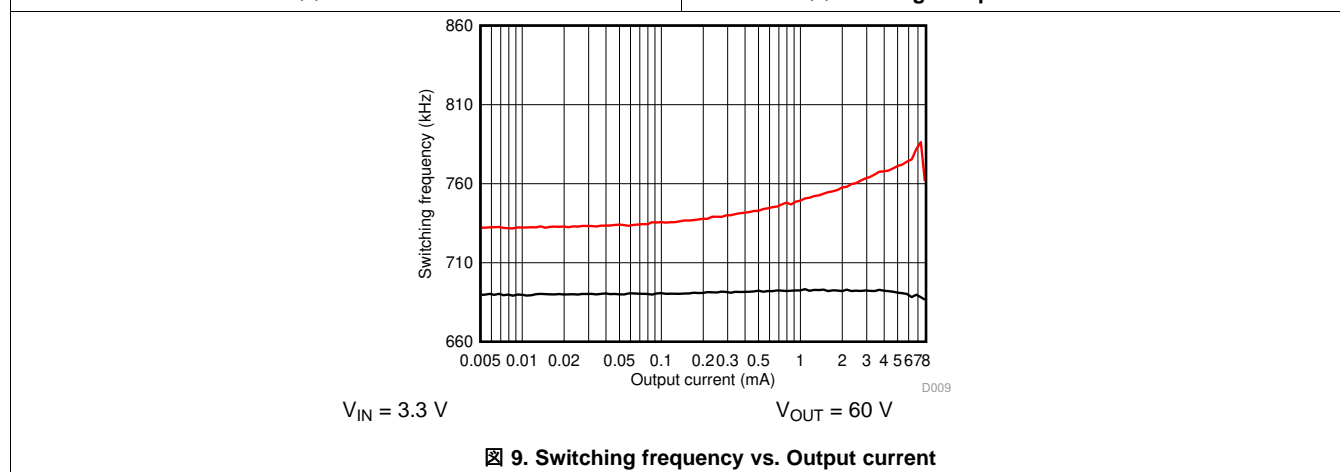

Figure 9. Switching frequency vs. Output current

7 Detailed Description

7.1 Overview

The TPS61391 is a fully integrated boost converter with an 85-V FET to convert a low input voltage to a higher voltage for biasing the APD. The TPS61391 supports an input voltage ranging from 2.5 V to 5.5 V. The device operates at a 700 kHz pulse-width modulation (PWM) crossing the whole load range.

There are two ratio options for the current proportional to APD current: the MON1 (4 : 5) and MON2 (1 : 5). By connecting a resistor from the mirror output (MON1 or MON2) to GND, the current flowing through the APD is converted into the voltage crossing the resistor from MON1 / MON2 to GND.

Additionally, a high power optical protection is integrated by clamping the pre-set current limit (program by the I_{SHORT} resistor). The response time of the high optical power is typically 0.5 μs . The device could recovery automatically when the high optical power is removed.

The device comes in a 3-mm \times 3-mm QFN package with the operating junction temperature covering from -40°C to 125°C .

7.2 Functional Block Diagram

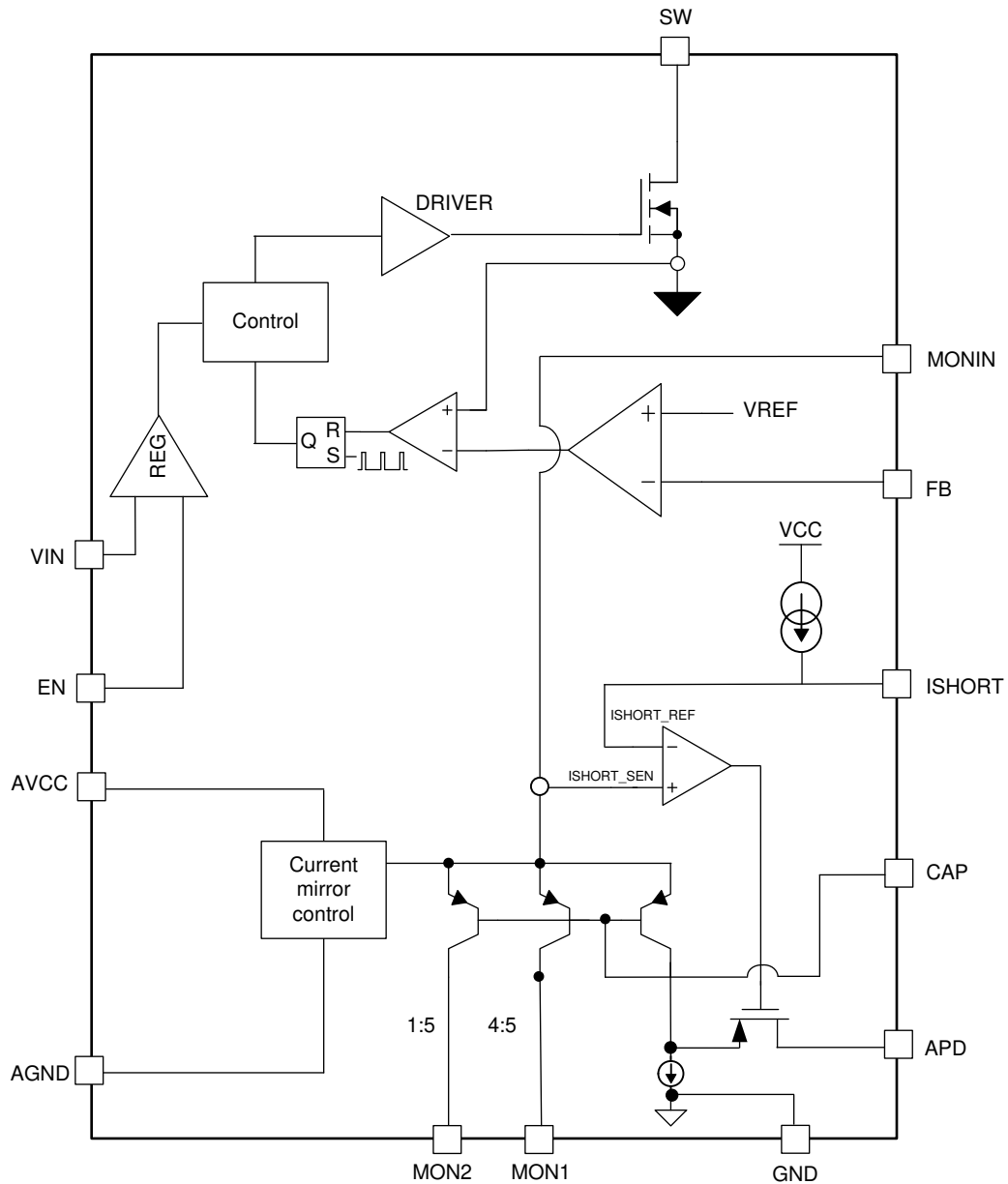

7.3 Feature Description

7.3.1 Undervoltage Lockout

An undervoltage lockout (UVLO) circuit stops the operation of the converter when the input voltage drops below the typical UVLO threshold of 2.5 V. A hysteresis of 200 mV is added so that the device cannot be enabled again until the input voltage goes up to 200 mV.

Feature Description (continued)

7.3.2 Enable and Disable

When the input voltage is above maximal UVLO rising threshold of 2.5 V and the EN pin is pulled above the high threshold (1.2 V min.), the TPS61391 is enabled. When the EN pin is pulled below the low threshold (0.4 maximum), the device goes into shutdown mode.

7.3.3 Current Mirror

There are two current mirror options for TPS61391: the gain of 4: 5 (MON1) and 1: 5 (MON2). The maximum voltage of MON1 and MON2 is 2.5 V.

7.3.4 High Optical Power Protection

There is an additional FET in series of power path connecting with the APD. When the current flowing through the APD exceeds the short protection threshold (set by connecting the resistor from I_{SHORT} to GND), the on resistance of the FET becomes larger to clamp the current within the protection threshold by lowering the APD bias voltage. It takes typically 0.5 μ s for the FET to respond in case of high optical power occurring.

When the high optical power condition releases, the TPS61391 recovers automatically back to the normal operation mode.

7.4 Device Functional Mode

7.4.1 PFM Operation

The TPS61391 integrates a power save mode with pulse frequency modulation (PFM) at the light load. When a light load condition occurs, the COMP pin voltage naturally decreases and reduces the peak current. When the COMP pin voltage further goes down with the load lowered and reaches the pre-set low threshold, the output of the error amplifier is clamped at this threshold and does not go down any more. If the load is further lowered, the device skips the switching cycles and reduces the switching losses and improves efficiency at the light load condition by reducing the average switching frequency.

8 Application and Implementation

注

Information in the following applications sections is not part of the TI component specification, and TI does not warrant its accuracy or completeness. TI's customers are responsible for determining suitability of components for their purposes. Customers should validate and test their design implementation to confirm system functionality.

8.1 Application Information

The TPS61391 is a step-up DC/DC converter with current monitor circuitry integrated. The following design procedure can be used to select component values for the TPS61391. This section presents a simplified discussion of the design process.

8.2 Typical Application

This application is designed for 2.5-V to 5.5-V input, and 60-V output user case



图 10. TPS61391 Typical Application

8.2.1 Design Requirement

For this design example, use 表 1 as the design parameters.

Typical Application (continued)
表 1. Design Parameters

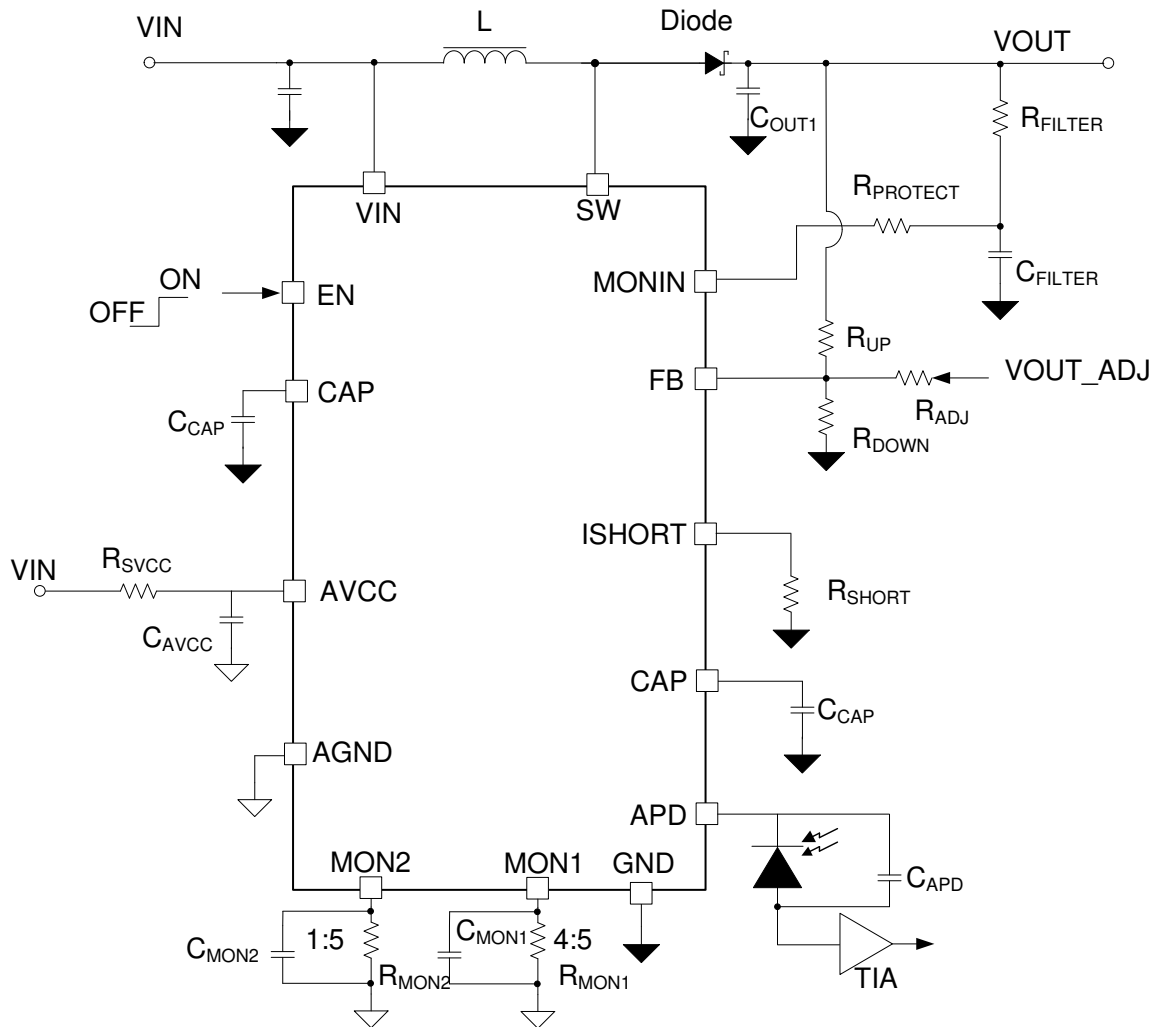
PARAMETER	VALUE
Input voltage range	2.5 V to 5.5 V
Output voltage	60 V
Operating frequency	700 kHz
APD Current	0 to 2 mA

8.2.2 Detailed Design Procedure
8.2.2.1 Selecting the Rectifier Diode

A Schottky diode is the preferred type for the rectifier diode due to its low forward voltage drop and small reverse recovery charge. Low reverse leakage current is important parameter when selecting the Schottky diode. The diode must be rated to handle the maximum output voltage plus the switching node ringing. Also, it must be able to handle the average output current.

8.2.2.2 Selecting the Inductor

It is suggested that the TPS61391 device works in the DCM operation; otherwise the output voltage would not be delivered for low input voltage to high output voltage.

With the device working in DCM operation, the maximum inductor could be calculated by equation 式 1 and 式 2:

$$L_{MAX} = \frac{V_{IN} \times D}{f_{SW} \times I_{LIM}}$$

where

- V_{IN} is input voltage
- D is duty cycle
- f_{SW} is switching frequency
- I_{LIM} is current limit

(1)

For instance, if $V_{IN} = 3.3$ V, $V_{OUT} = 60$ V, $f_{SW} = 600$ kHz, $I_{LIM} = 0.8$ A, the $L_{MAX} = 6.5$ μ H

However, there is minimum inductance is determined by the power delivered to the output side at given input condition.

$$L_{MIN} = 2 \times \frac{V_{OUT} \times I_{OUT}}{eff \times f_{SW} \times I_{LIM}^2}$$

where

- V_{OUT} is output voltage
- I_{OUT} is output current
- eff is the efficiency
- f_{SW} is switching frequency
- I_{LIM} is current limit

(2)

For instance, if $I_{OUT} = 8$ mA, $V_{OUT} = 60$ V, $f_{SW} = 600$ kHz, $I_{LIM} = 0.8$ A, $eff = 0.6$, the $L_{MIN} = 4.2$ μ H

With the calculation aforementioned, the operating inductor is recommended between the L_{MIN} and L_{MAX} .

The 4.7 μ H inductance is optimum value for using the TPS61391 in application.

8.2.2.3 Selecting Output Capacitor

Use low ESR capacitors at the output to minimize output voltage ripple. Use only X5R and X7R types, which retain their capacitance over wider voltage and temperature ranges than other types. Typically use a 0.1- μ F to 1- μ F capacitor for output voltage. Take care when evaluating the derating of a ceramic capacitor under the DC bias. Ceramic capacitors can derate its capacitance at its rated voltage. Therefore, consider enough margins on the voltage rating to ensure adequate capacitance at the required output voltage.

8.2.2.4 Selecting Filter Resistor and Capacitor

TI recommends an additional R-C filter be added for low ripple applications. The filter parameters is characterized based on the ripple requirement. Typically, use a 100-Ω and 0.1-μF filter to reduce the switching output ripple.

8.2.2.5 Setting the Output Voltage

The output voltage of the TPS61391 is externally adjustable using a resistor divider network. The relationship between the output voltage and the resistor divider is given by 式 3.

$$V_{OUT} = V_{FB} \times \left(1 + \frac{R_{UP}}{R_{DOWN}}\right)$$

where

- V_{OUT} is the output voltage
- R_{UP} the top divider resistor
- R_{DOWN} is the bottom divider resistor

(3)

Choose R_{DOWN} to be approximately 10 kΩ. Slightly increasing or decreasing R_{DOWN} can result in closer output voltage matching when using standard value resistors. In this design, $R_{DOWN} = 10$ kΩ and $R_{UP} = 487$ kΩ, resulting in an output voltage of 60 V.

8.2.2.6 Selecting Capacitor for CAP pin

TI recommends placing a ceramic capacitor from CAP pin to GND to lower the noise for the APD current mirror. A ceramic capacitor between 10 nF and 100 nF is recommended from CAP pin to GND.

8.2.2.7 Selecting Capacitor for AVCC pin

The control circuitry is powered by AVCC. A ceramic capacitor must be placed close to AVCC, with a typical capacitor value of 2.2 μF.

8.2.2.8 Selecting Capacitor for APD pin

A ceramic capacitor is required to make the APD current mirror more accurately against the noise coupling. The recommended values are from 100 pF to 470 pF.

8.2.2.9 Selecting the Resistors of MON1 or MON2

The TPS61391 provides two currents proportional to APD current on the MON pins, 4 : 5 and 1 : 5. The voltage of the resistors connecting to the MON pins convert the APD current to voltage.

8.2.2.10 Selecting the Capacitors of MON1 or MON2

The capacitors are added to the MON1 or MON2 pins to decouple the noise of APD transient current.

8.2.2.11 Selecting the Short Current Limit

The output current short-protection threshold of the TPS61391 can be programmed by an external resistor using 式 4.

$$I_{SHORT} = \frac{100}{R_{SHORT}}$$

where

- I_{SHORT} (mA) is the short protection threshold
 - R_{SHORT} (k Ω) is the resistor connecting from ISHORT pin to GND
- (4)

For instance, if $R_{SHORT} = 25\text{ k}\Omega$, the $I_{SHORT} = 4\text{ mA}$.

8.2.3 Application Curves

Typical condition $V_{IN} = 3.3\text{ V}$, $V_{OUT} = 60\text{ V}$, $R_{SHORT} = 5\text{ k}\Omega$, $R_{MON1/2} = 3.01\text{ k}\Omega$ and $C_{MON1/2} = 10\text{ pF}$.

Application waveforms are measured with the inductor $4.7\text{ }\mu\text{H}$ and the output capacitance $0.1\text{ }\mu\text{F}$ at room temperature.

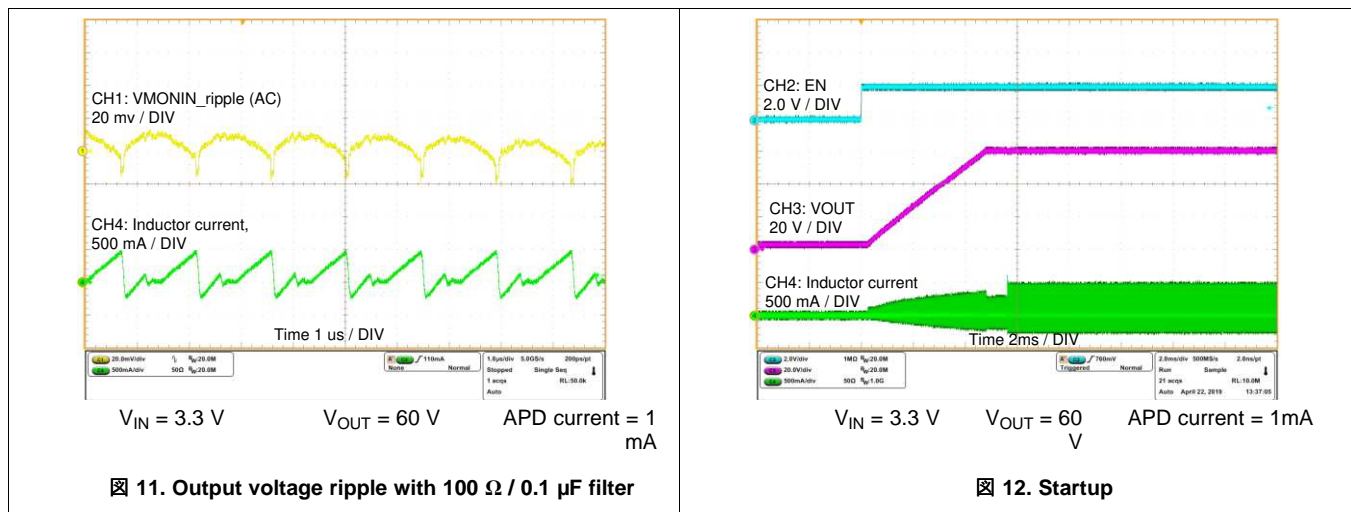

9 Power Supply Recommendations

The device is designed to operate from an input voltage supply range between 2.5 V and 5.5 V. This input supply must be well regulated. If the input supply is located more than a few inches from the device, the bulk capacitance may be required in addition to the ceramic bypass capacitors. An electrolytic capacitor with a value of 47 μF is a typical choice.

10 Layout

10.1 Layout Guidelines

The basic PCB board layout requires a separation of sensitive signal and power paths. If the layout is not carefully done, the regulator could suffer from the instability or noise problems. Use the following checklist to get good performance for a well-designed board:

- Minimize the high current path including the switch FET, rectifier FET, and the output capacitor. This loop contains high di/dt switching currents (nano seconds per ampere) and easy to transduce the high frequency noise;
- Place the noise sensitive network like current mirror output (MON1, MON2) being far away from the SW trace;
- Split the ground for the power GND, signal GND. Use a separate ground trace to connect the current monitor and boost circuitry. Connect this ground trace to the main power ground at a single point to minimize circulating currents.

10.2 Layout Example

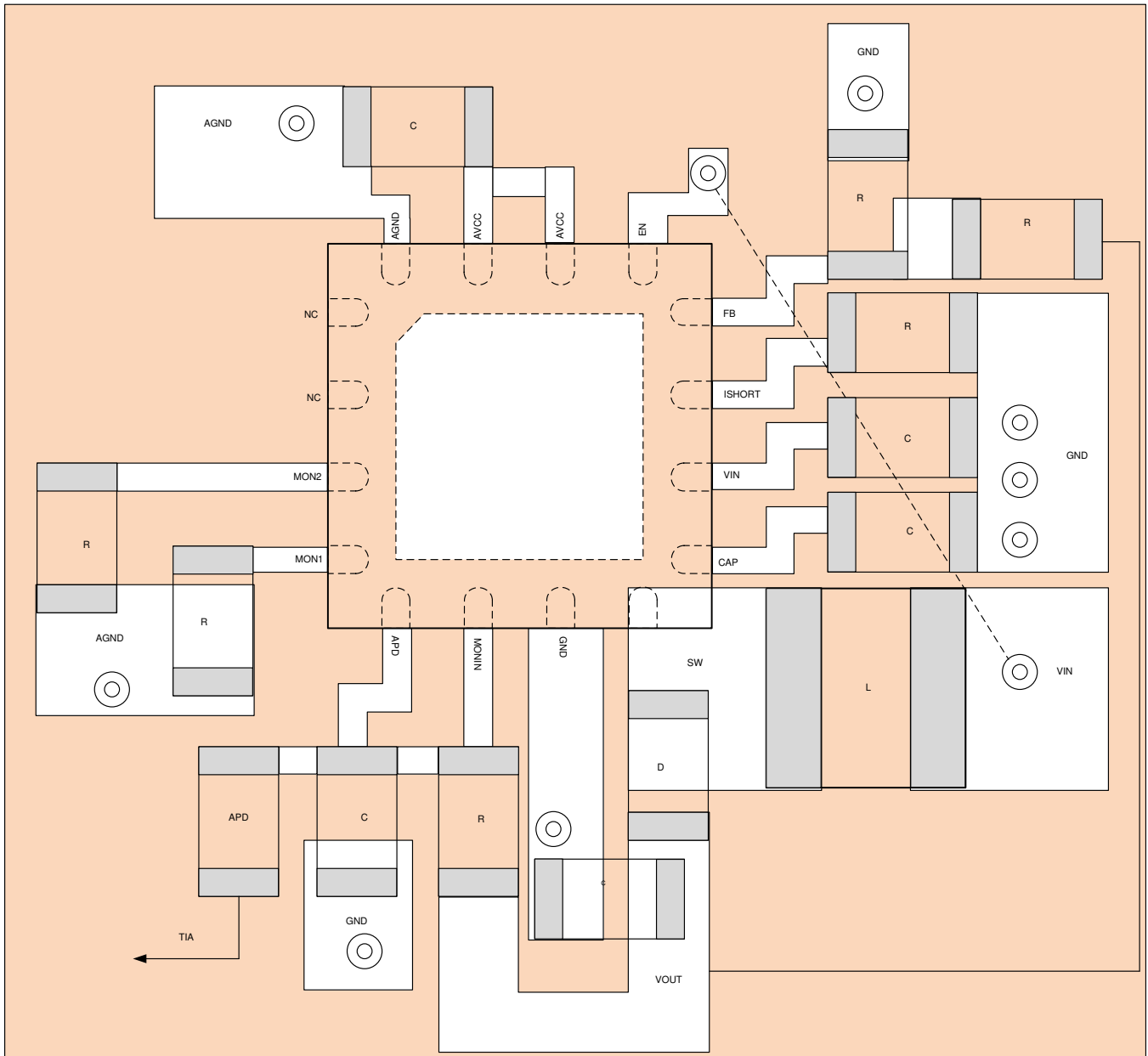

☒ 13. Layout Example

11 デバイスおよびドキュメントのサポート

11.1 ドキュメントのサポート

11.1.1 関連資料

関連資料については、以下を参照してください。

- 『TPS61391EVM-058 Evaluation Module User's Guide』、[SLVUBS9](#) (英語)

11.2 ドキュメントの更新通知を受け取る方法

ドキュメントの更新についての通知を受け取るには、[ti.com](#)のデバイス製品フォルダを開いてください。右上の「アラートを受け取る」をクリックして登録すると、変更されたすべての製品情報に関するダイジェストを毎週受け取れます。変更の詳細については、修正されたドキュメントに含まれている改訂履歴をご覧ください。

11.3 サポート・リソース

[TI E2E™ support forums](#) are an engineer's go-to source for fast, verified answers and design help — straight from the experts. Search existing answers or ask your own question to get the quick design help you need.

Linked content is provided "AS IS" by the respective contributors. They do not constitute TI specifications and do not necessarily reflect TI's views; see TI's [Terms of Use](#).

11.4 商標

E2E is a trademark of Texas Instruments.

All other trademarks are the property of their respective owners.

11.5 静電気放電に関する注意事項



すべての集積回路は、適切なESD保護方法を用いて、取扱いと保存を行うようにして下さい。

静電気放電はわずかな性能の低下から完全なデバイスの故障に至るまで、様々な損傷を与えます。高精度の集積回路は、損傷に対して敏感であり、極めてわずかなパラメータの変化により、デバイスに規定された仕様に適合しなくなる場合があります。

11.6 Glossary

[SLYZ022](#) — *TI Glossary*.

This glossary lists and explains terms, acronyms, and definitions.

12 メカニカル、パッケージ、および注文情報

以降のページには、メカニカル、パッケージ、および注文に関する情報が記載されています。この情報は、そのデバイスについて利用可能な最新のデータです。このデータは予告なく変更されることがあり、ドキュメントが改訂される場合もあります。本データシートのブラウザ版を使用されている場合は、画面左側の説明をご覧ください。

EXAMPLE BOARD LAYOUT

RTE0016J

WQFN - 0.8 mm max height

PLASTIC QUAD FLATPACK - NO LEAD

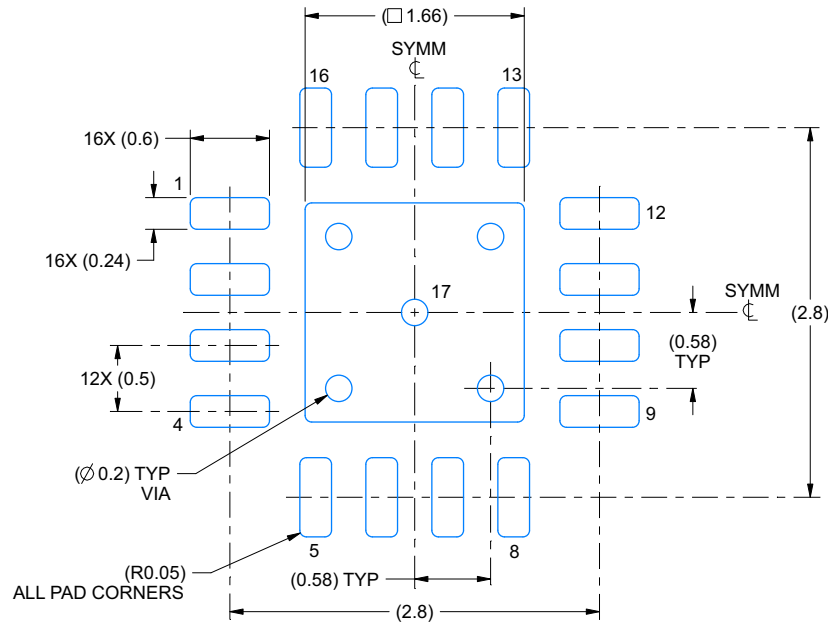

LAND PATTERN EXAMPLE
EXPOSED METAL SHOWN
SCALE:20X

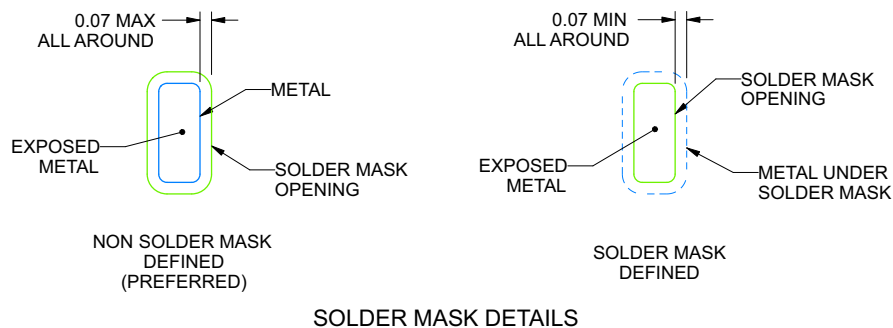

SOLDER MASK DETAILS

4224278/A 05/2018

NOTES: (continued)

4. This package is designed to be soldered to a thermal pad on the board. For more information, see Texas Instruments literature number SLUA271 (www.ti.com/lit/sluea271).
5. Vias are optional depending on application, refer to device data sheet. If any vias are implemented, refer to their locations shown on this view. It is recommended that vias under paste be filled, plugged or tented.

EXAMPLE STENCIL DESIGN

RTE0016J

WQFN - 0.8 mm max height

PLASTIC QUAD FLATPACK - NO LEAD

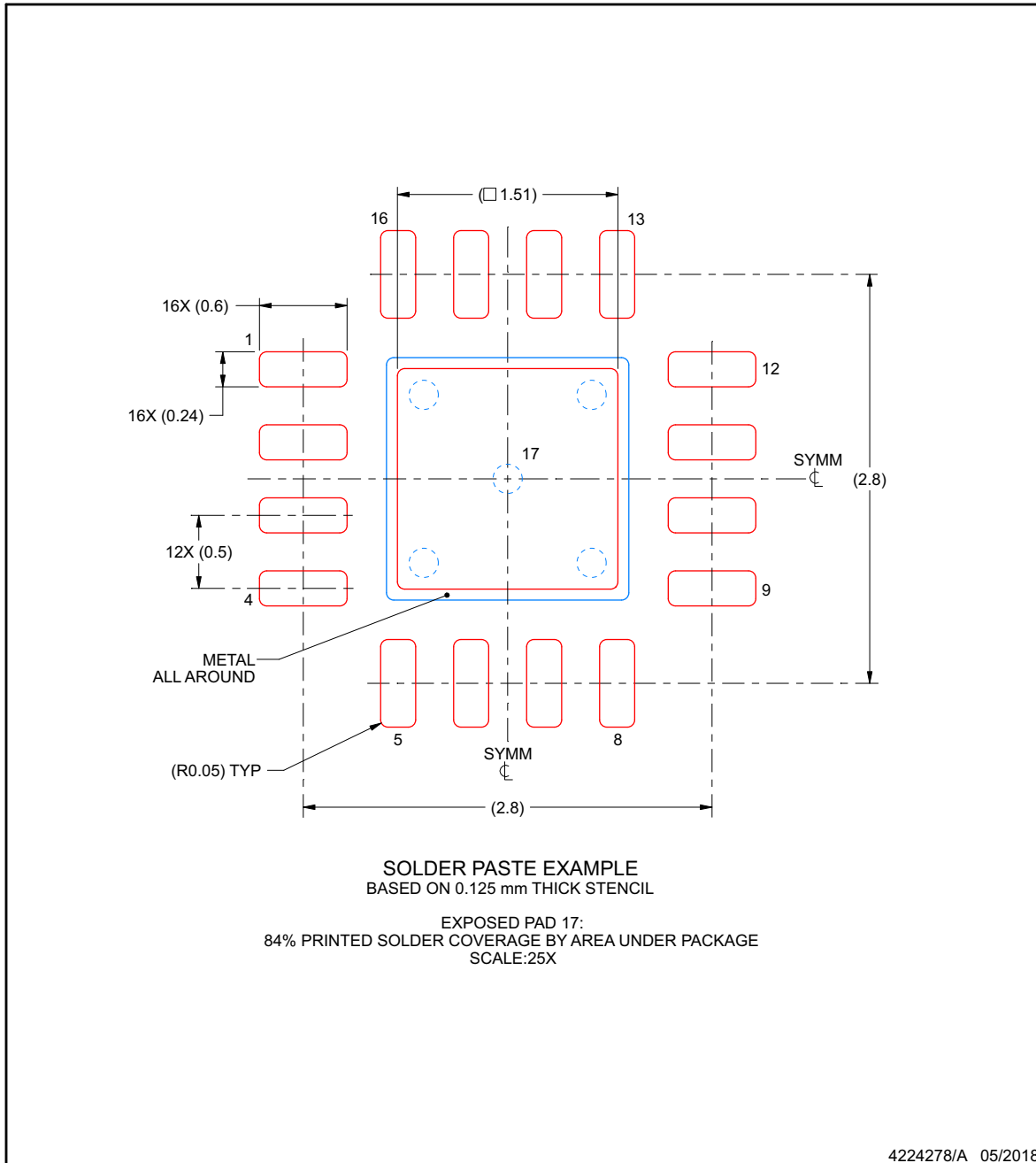

NOTES: (continued)

6. Laser cutting apertures with trapezoidal walls and rounded corners may offer better paste release. IPC-7525 may have alternate design recommendations.

PACKAGING INFORMATION

Orderable Device	Status (1)	Package Type	Package Drawing	Pins	Package Qty	Eco Plan (2)	Lead finish/ Ball material (6)	MSL Peak Temp (3)	Op Temp (°C)	Device Marking (4/5)	Samples
TPS61391RTER	ACTIVE	WQFN	RTE	16	3000	RoHS & Green	NIPDAU	Level-1-260C-UNLIM	-40 to 125	22GH	Samples
TPS61391RTET	ACTIVE	WQFN	RTE	16	250	RoHS & Green	NIPDAU	Level-1-260C-UNLIM	-40 to 125	22GH	Samples

(1) The marketing status values are defined as follows:

ACTIVE: Product device recommended for new designs.

LIFEBUY: TI has announced that the device will be discontinued, and a lifetime-buy period is in effect.

NRND: Not recommended for new designs. Device is in production to support existing customers, but TI does not recommend using this part in a new design.

PREVIEW: Device has been announced but is not in production. Samples may or may not be available.

OBSOLETE: TI has discontinued the production of the device.

(2) **RoHS:** TI defines "RoHS" to mean semiconductor products that are compliant with the current EU RoHS requirements for all 10 RoHS substances, including the requirement that RoHS substance do not exceed 0.1% by weight in homogeneous materials. Where designed to be soldered at high temperatures, "RoHS" products are suitable for use in specified lead-free processes. TI may reference these types of products as "Pb-Free".

RoHS Exempt: TI defines "RoHS Exempt" to mean products that contain lead but are compliant with EU RoHS pursuant to a specific EU RoHS exemption.

Green: TI defines "Green" to mean the content of Chlorine (Cl) and Bromine (Br) based flame retardants meet JS709B low halogen requirements of <=1000ppm threshold. Antimony trioxide based flame retardants must also meet the <=1000ppm threshold requirement.

(3) MSL, Peak Temp. - The Moisture Sensitivity Level rating according to the JEDEC industry standard classifications, and peak solder temperature.

(4) There may be additional marking, which relates to the logo, the lot trace code information, or the environmental category on the device.

(5) Multiple Device Markings will be inside parentheses. Only one Device Marking contained in parentheses and separated by a "~" will appear on a device. If a line is indented then it is a continuation of the previous line and the two combined represent the entire Device Marking for that device.

(6) Lead finish/Ball material - Orderable Devices may have multiple material finish options. Finish options are separated by a vertical ruled line. Lead finish/Ball material values may wrap to two lines if the finish value exceeds the maximum column width.

Important Information and Disclaimer:The information provided on this page represents TI's knowledge and belief as of the date that it is provided. TI bases its knowledge and belief on information provided by third parties, and makes no representation or warranty as to the accuracy of such information. Efforts are underway to better integrate information from third parties. TI has taken and continues to take reasonable steps to provide representative and accurate information but may not have conducted destructive testing or chemical analysis on incoming materials and chemicals. TI and TI suppliers consider certain information to be proprietary, and thus CAS numbers and other limited information may not be available for release.

In no event shall TI's liability arising out of such information exceed the total purchase price of the TI part(s) at issue in this document sold by TI to Customer on an annual basis.

GENERIC PACKAGE VIEW

RTE 16

WQFN - 0.8 mm max height

3 x 3, 0.5 mm pitch

PLASTIC QUAD FLATPACK - NO LEAD

This image is a representation of the package family, actual package may vary.
Refer to the product data sheet for package details.

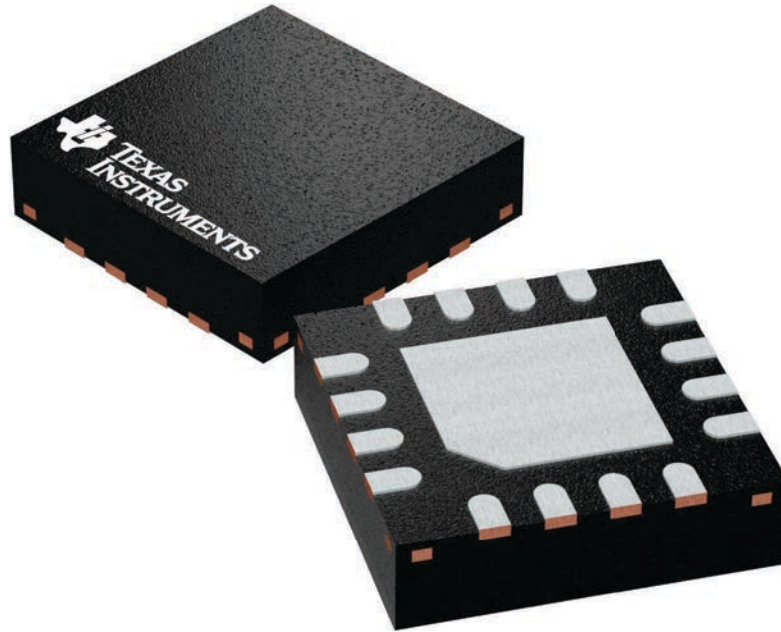

4225944/A

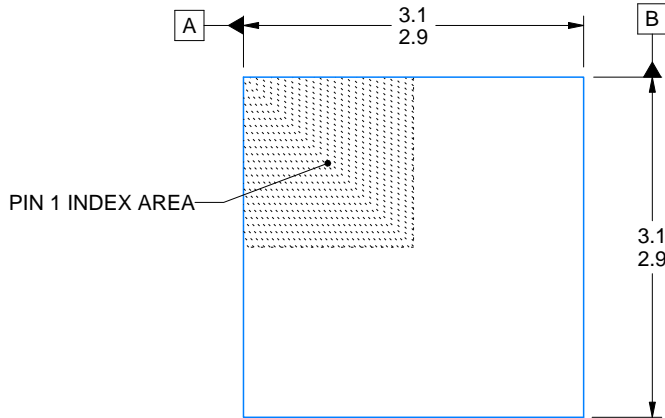

SIDE WALL METAL THICKNESS DIM A	
OPTION 1	OPTION 2
0.1	0.2

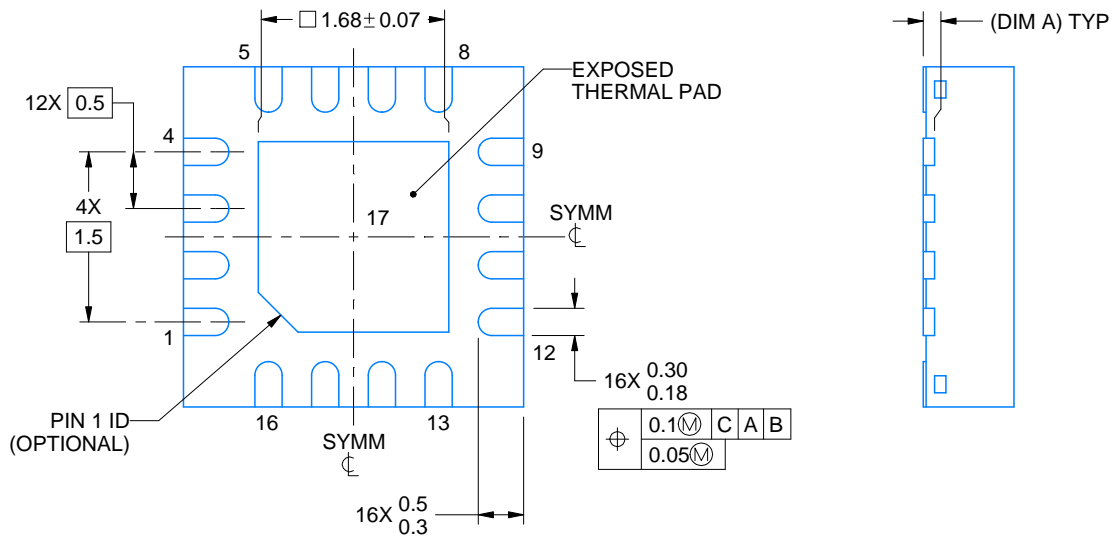
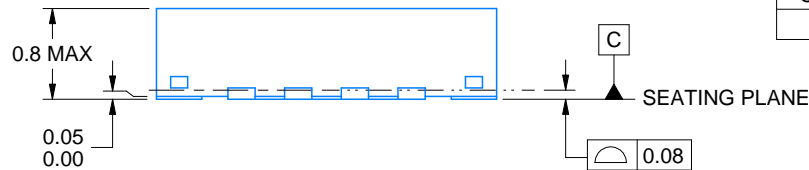

4219117/B 04/2022

NOTES:

1. All linear dimensions are in millimeters. Any dimensions in parenthesis are for reference only. Dimensioning and tolerancing per ASME Y14.5M.
2. This drawing is subject to change without notice.
3. The package thermal pad must be soldered to the printed circuit board for thermal and mechanical performance.

EXAMPLE BOARD LAYOUT

RTE0016C

WQFN - 0.8 mm max height

PLASTIC QUAD FLATPACK - NO LEAD

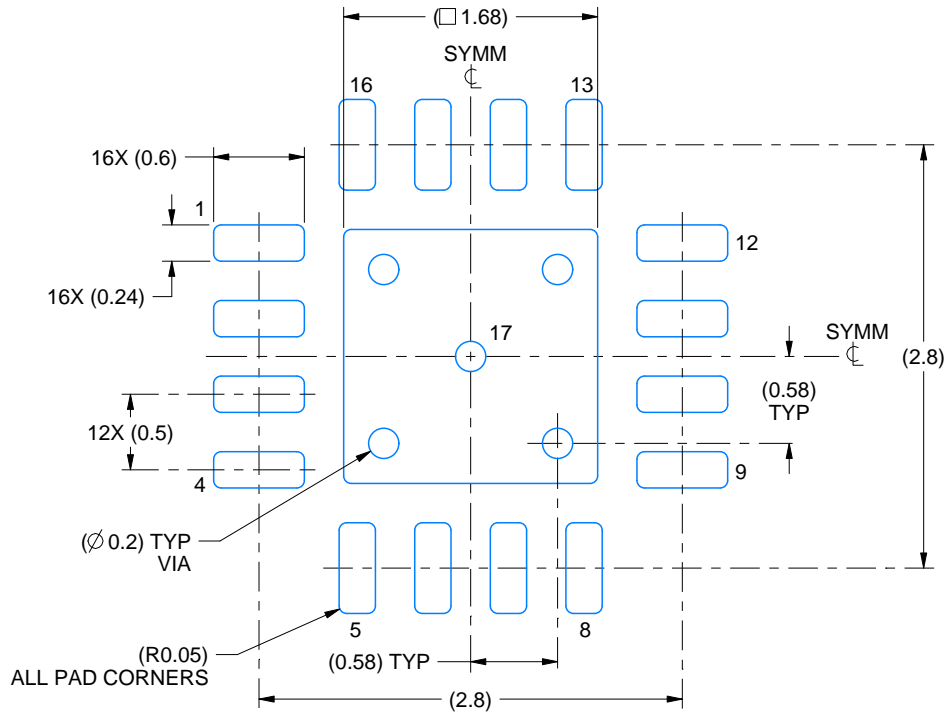

LAND PATTERN EXAMPLE
EXPOSED METAL SHOWN
SCALE:20X

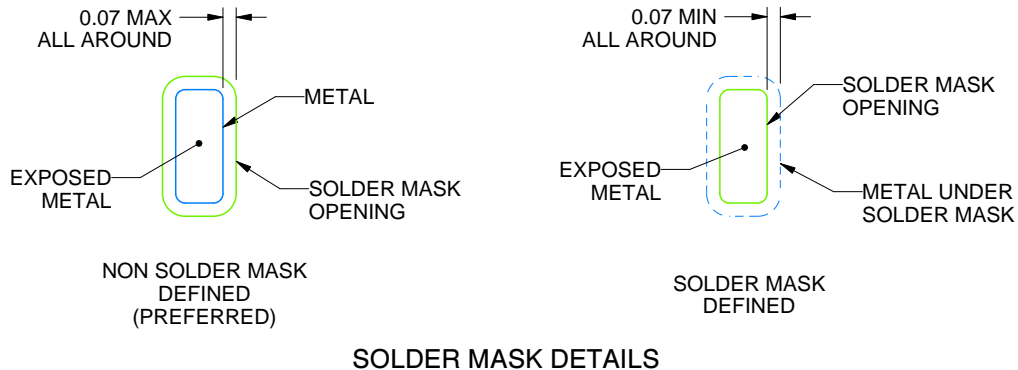

SOLDER MASK DETAILS

4219117/B 04/2022

NOTES: (continued)

4. This package is designed to be soldered to a thermal pad on the board. For more information, see Texas Instruments literature number SLUA271 (www.ti.com/lit/sluea271).
5. Vias are optional depending on application, refer to device data sheet. If any vias are implemented, refer to their locations shown on this view. It is recommended that vias under paste be filled, plugged or tented.

EXAMPLE STENCIL DESIGN

RTE0016C

WQFN - 0.8 mm max height

PLASTIC QUAD FLATPACK - NO LEAD

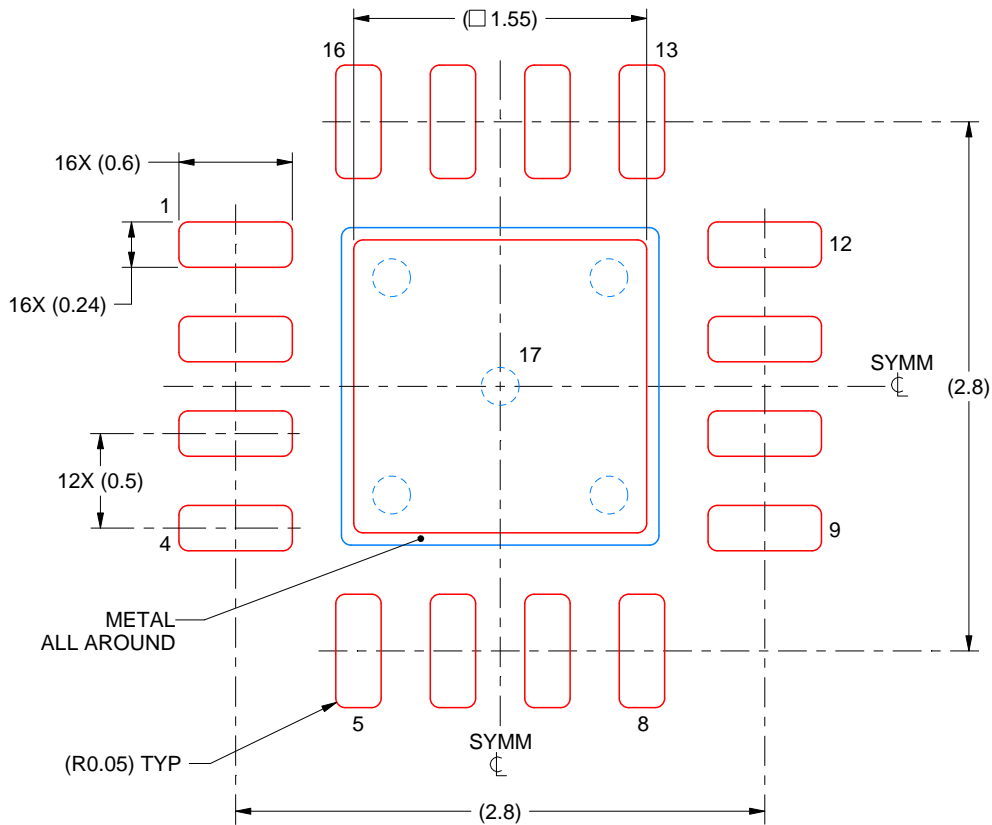

SOLDER PASTE EXAMPLE
BASED ON 0.125 mm THICK STENCIL

EXPOSED PAD 17:
85% PRINTED SOLDER COVERAGE BY AREA UNDER PACKAGE
SCALE:25X

4219117/B 04/2022

NOTES: (continued)

6. Laser cutting apertures with trapezoidal walls and rounded corners may offer better paste release. IPC-7525 may have alternate design recommendations.

重要なお知らせと免責事項

TI は、技術データと信頼性データ(データシートを含みます)、設計リソース(リファレンス・デザインを含みます)、アプリケーションや設計に関する各種アドバイス、Web ツール、安全性情報、その他のリソースを、欠陥が存在する可能性のある「現状のまま」提供しており、商品性および特定目的に対する適合性の黙示保証、第三者の知的財産権の非侵害保証を含むいかなる保証も、明示的または黙示的にかかわらず拒否します。

これらのリソースは、TI 製品を使用する設計の経験を積んだ開発者への提供を意図したものです。(1) お客様のアプリケーションに適した TI 製品の選定、(2) お客様のアプリケーションの設計、検証、試験、(3) お客様のアプリケーションに該当する各種規格や、その他のあらゆる安全性、セキュリティ、規制、または他の要件への確実な適合に関する責任を、お客様のみが単独で負うものとし、

上記の各種リソースは、予告なく変更される可能性があります。これらのリソースは、リソースで説明されている TI 製品を使用するアプリケーションの開発の目的でのみ、TI はその使用をお客様に許諾します。これらのリソースに関して、他の目的で複製することや掲載することは禁止されています。TI や第三者の知的財産権のライセンスが付与されている訳ではありません。お客様は、これらのリソースを自身で使用した結果発生するあらゆる申し立て、損害、費用、損失、責任について、TI およびその代理人を完全に補償するものとし、TI は一切の責任を拒否します。

TI の製品は、[TI の販売条件](#)、または [ti.com](https://www.ti.com) やかかる TI 製品の関連資料などのいずれかを通じて提供する適用可能な条項の下で提供されています。TI がこれらのリソースを提供することは、適用される TI の保証または他の保証の放棄の拡大や変更を意味するものではありません。

お客様がいかなる追加条項または代替条項を提案した場合でも、TI はそれらに異議を唱え、拒否します。

郵送先住所：Texas Instruments, Post Office Box 655303, Dallas, Texas 75265

Copyright © 2022, Texas Instruments Incorporated