

TPS7A16A-Q1

60V、5 μ A I_Q、100mA、低ドロップアウト電圧レギュレータ、イネーブルおよびパワー・グッド搭載

1 特長

- 車載アプリケーションに対応
- 下記内容で AEC-Q100 認定済み
 - デバイス温度グレード 1: 動作時周囲温度範囲 –40°C ~ 125°C
 - デバイス HBM ESD 分類レベル 2
 - デバイス CDM ESD 分類レベル C3B
- 広い入力電圧範囲: 3V ~ 60V
- 超低静止電流: 5 μ A
- シャットダウン時の静止電流: 1 μ A
- 出力電流: 100mA
- 低ドロップアウト電圧: 60mV (20mA 時)
- 精度: 2%
- 利用可能なバージョン:
 - 固定出力電圧: 3.3V、5V
 - 可変バージョン: 約 1.2 ~ 18.5V
- 遅延時間をプログラム可能なパワー・グッド
- 電流制限およびサーマル・シャットダウン保護機能
- 2.2 μ F 以上のセラミック出力コンデンサで安定動作
- パッケージ: 熱特性に優れた HVSSOP-8 PowerPAD™

2 アプリケーション

- 緊急通話 (eCall)
- バッテリー管理システム (BMS)
- オンボード (OBC) およびワイヤレス充電器
- DC/DC コンバータ

3 概要

TPS7A16A-Q1 超低消費電力、低ドロップアウト (LDO) 電圧レギュレータは、非常に低い静止電流、高い入力電圧、および熱特性の優れた小型パッケージが特長です。

TPS7A16A-Q1 は、連続的または散発的 (電源バックアップ) に使用するバッテリー駆動アプリケーション向けに設計されています。こうした用途では、システムのバッテリー駆動時間を伸ばすために超低静止電流が不可欠です。

TPS7A16A-Q1 には、標準の CMOS (Complementary Metal Oxide Semiconductor) ロジック互換のイネーブル・ピン (EN) と、オープン・ドレインでアクティブ HIGH のパワー・グッド出力 (PG) があり、遅延をユーザーがプログラム可能です。これらのピンは、電源レールのシーケンシングを必要とするマイクロコントローラ・ベースのバッテリー駆動アプリケーションで使うことを目的としています。

さらに TPS7A16A-Q1 は、セル数の多い電動工具パックから車載アプリケーションに至るまで、各種のマルチセル・ソリューションから低電圧電源を生成するのに理想的です。適切にレギュレーションされた電圧レールを提供できるだけでなく、過渡電圧時にもレギュレーションを維持できます。これらの機能により、よりシンプルでコスト効率の優れた電氣的サージ保護回路が実現できます。

製品情報⁽¹⁾

型番	パッケージ	本体サイズ (公称)
TPS7A16A-Q1	HVSSOP (8)	3.00mm x 3.00mm

(1) 利用可能なすべてのパッケージについては、このデータシートの末尾にある注文情報を参照してください。

代表的なアプリケーションの回路図

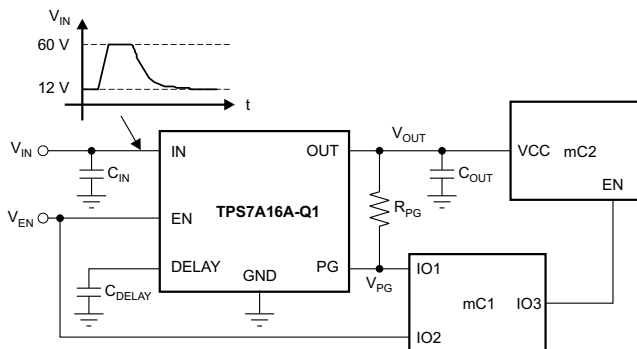

目次

1	特長	1	7.4	Device Functional Modes	10
2	アプリケーション	1	8	Application and Implementation	10
3	概要	1	8.1	Application Information	10
4	改訂履歴	2	8.2	Typical Applications	11
5	Pin Configuration and Functions	3	9	Power Supply Recommendations	15
6	Specifications	4	10	Layout	15
6.1	Absolute Maximum Ratings	4	10.1	Layout Guidelines	15
6.2	ESD Ratings	4	10.2	Layout Examples	16
6.3	Recommended Operating Conditions	4	11	デバイスおよびドキュメントのサポート	18
6.4	Thermal Information	4	11.1	ドキュメントの更新通知を受け取る方法	18
6.5	Electrical Characteristics	5	11.2	コミュニティ・リソース	18
6.6	Typical Characteristics	6	11.3	商標	18
7	Detailed Description	9	11.4	静電気放電に関する注意事項	18
7.1	Overview	9	11.5	Glossary	18
7.2	Functional Block Diagram	9	12	メカニカル、パッケージ、および注文情報	18
7.3	Feature Description	9			

4 改訂履歴

資料番号末尾の英字は改訂を表しています。その改訂履歴は英語版に準じています。

2019年2月発行のものから更新

Page

•	ステータスを「事前情報」から「量産データ」に変更	1
---	--------------------------	---

5 Pin Configuration and Functions

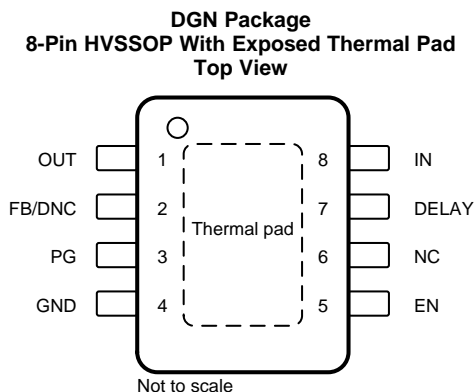

NC – No internal connection

Pin Functions

PIN		I/O	DESCRIPTION
NAME	NO.		
DELAY	7	O	Delay pin. Connect a capacitor to GND to adjust the PG delay time; leave open if the reset function is not needed.
EN	5	I	Enable pin. This pin turns the regulator on or off. If $V_{EN} \geq V_{EN_HI}$, the regulator is enabled. If $V_{EN} \leq V_{EN_LO}$, the regulator is disabled. If not used, the EN pin can be connected to IN. Make sure that $V_{EN} \leq V_{IN}$ at all times.
FB/DNC	2	I	For the adjustable version, the feedback pin is the input to the control-loop error amplifier. This pin is used to set the output voltage of the device when the regulator output voltage is set by external resistors. For the fixed-voltage versions, do not connect to this pin. Do not route this pin to any electrical net, not even to GND or IN.
GND	4	—	Ground pin
IN	8	I	Regulator input supply pin. A capacitor $> 0.1 \mu\text{F}$ must be tied from this pin to ground to assure stability. TI recommends connecting a $10\text{-}\mu\text{F}$ ceramic capacitor from IN to GND (as close to the device as possible) to reduce circuit sensitivity to printed-circuit-board (PCB) layout, especially when long input tracer or high source impedances are encountered.
NC	6	---	This pin can be left open or tied to any voltage between GND and IN.
OUT	1	O	Regulator output pin. A capacitor $> 2.2 \mu\text{F}$ must be tied from this pin to ground to assure stability. TI recommends connecting a $10\text{-}\mu\text{F}$ ceramic capacitor from OUT to GND (as close to the device as possible) to maximize ac performance.
PG	3	O	Power-good pin. Open-collector output; leave open or connect to GND if the power-good function is not needed.
Thermal pad	Pad	---	Solder to the printed circuit board (PCB) to enhance thermal performance. Although the thermal pad can be left floating, TI highly recommends connecting the thermal pad to the GND plane.

6 Specifications

6.1 Absolute Maximum Ratings

over operating ambient temperature range (unless otherwise noted)⁽¹⁾

		MIN	MAX	UNIT
Voltage	IN pin to GND pin	-0.3	62	V
	OUT pin to GND pin	-0.3	20	
	OUT pin to IN pin	-62	0.3	
	FB pin to GND pin	-0.3	3	
	FB pin to IN pin	-62	0.3	
	EN pin to IN pin	-62	0.3	
	EN pin to GND pin	-0.3	62	
	PG pin to GND pin	-0.3	5.5	
	DELAY pin to GND pin	-0.3	5.5	
Current	Peak output	Internally limited		
Temperature	Operating virtual junction, T_J , absolute maximum ⁽²⁾	-40	150	°C
	Storage, T_{STG}	-65	150	

- (1) Stresses beyond those listed under *Absolute Maximum Ratings* may cause permanent damage to the device. These are stress ratings only, which do not imply functional operation of the device at these or any other conditions beyond those indicated under *Recommended Operating Conditions*. Exposure to absolute-maximum-rated conditions for extended periods may affect device reliability.
- (2) Permanent damage does not occur to the part operating within this range, though electrical performance is not guaranteed outside the operating ambient temperature range.

6.2 ESD Ratings

			VALUE	UNIT	
$V_{(ESD)}$	Electrostatic discharge	Human-body model (HBM), per ANSI/ESDA/JEDEC JS-001 ⁽¹⁾	±2000	V	
		Charged-device model (CDM), per JEDEC specification JESD22-C101 ⁽²⁾	Corner pins (OUT, GND, IN, and EN)		±750
			Other pins		±500

- (1) JEDEC document JEP155 states that 500-V HBM allows safe manufacturing with a standard ESD control process.
- (2) JEDEC document JEP157 states that 250-V CDM allows safe manufacturing with a standard ESD control process.

6.3 Recommended Operating Conditions

over operating ambient temperature range (unless otherwise noted)

		MIN	NOM	MAX	UNIT
V_{IN}	Input voltage	3		60	V
V_{OUT}	Output voltage	1.2		18.5	V
EN	EN pin voltage	0		V_{IN}	V
	EN pin slew-rate, voltage ramp-up			1.5	V/ μ s
DELAY	Delay pin voltage	0		5	V
PG	Power-good pin voltage	0		5	V

6.4 Thermal Information

THERMAL METRIC ⁽¹⁾		TPS7A16A-Q1	UNIT
		DGN (HVSSOP)	
		8 PINS	
$R_{\theta JA}$	Junction-to-ambient thermal resistance	52.5	°C/W
$R_{\theta JC(top)}$	Junction-to-case(top) thermal resistance	72.2	°C/W
$R_{\theta JB}$	Junction-to-board thermal resistance	24.1	°C/W
Ψ_{JT}	Junction-to-top characterization parameter	2.3	°C/W
Ψ_{JB}	Junction-to-board characterization parameter	24.0	°C/W
$R_{\theta JC(bot)}$	Junction-to-case(bottom) thermal resistance	10.1	°C/W

- (1) For more information about traditional and new thermal metrics, see the Semiconductor and [IC Package Thermal Metrics](#) application report.

6.5 Electrical Characteristics

at $T_A = -40^\circ\text{C}$ to $+125^\circ\text{C}$, $V_{IN} = V_{OUT(NOM)} + 500\text{ mV}$ or $V_{IN} = 3\text{ V}$ (whichever is greater), $V_{EN} = V_{IN}$, $I_{OUT} = 10\text{ }\mu\text{A}$, $C_{IN} = 2.2\text{ }\mu\text{F}$, $C_{OUT} = 2.2\text{ }\mu\text{F}$, and FB tied to OUT (unless otherwise noted)

PARAMETER		TEST CONDITIONS	MIN	TYP	MAX	UNIT
V_{IN}	Input voltage range		3		60	V
V_{REF}	Internal reference	$T_A = 25^\circ\text{C}$, $V_{FB} = V_{REF}$, $V_{IN} = 3\text{ V}$, $I_{OUT} = 10\text{ }\mu\text{A}$	1.169	1.193	1.217	V
V_{UVLO}	Undervoltage lockout threshold			2		V
V_{OUT}	Output voltage range	$V_{IN} \geq V_{OUT(NOM)} + 0.5\text{ V}$		V_{REF}	18.5	V
	Overall V_{OUT} accuracy	$V_{OUT(NOM)} + 0.5\text{ V} \leq V_{IN} \leq 60\text{ V}^{(1)}$, $10\text{ }\mu\text{A} \leq I_{OUT} \leq 100\text{ mA}$	-2%		2%	
$\Delta V_{O(\Delta V)}$	Line regulation	$3\text{ V} \leq V_{IN} \leq 60\text{ V}$		± 1		% V_{OUT}
$\Delta V_{O(\Delta I)}$	Load regulation	$10\text{ }\mu\text{A} \leq I_{OUT} \leq 100\text{ mA}$		± 1		% V_{OUT}
V_{DO}	Dropout voltage	$V_{IN} = 0.95 \times V_{OUT(NOM)}$, $I_{OUT} = 20\text{ mA}$		60		mV
		$V_{IN} = 0.95 \times V_{OUT(NOM)}$, $I_{OUT} = 100\text{ mA}$		265	500	
I_{LIM}	Current limit	$V_{OUT} = 90\% V_{OUT(NOM)}$, $V_{IN} = V_{OUT(NOM)} + 1\text{ V}^{(2)}$	101	225	400	mA
		$V_{OUT} = 90\% V_{OUT(NOM)}$, $V_{IN} = 3\text{ V}^{(3)}$	101	225	400	
I_{GND}	Ground current	$3\text{ V} \leq V_{IN} \leq 60\text{ V}$, $I_{OUT} = 10\text{ }\mu\text{A}$		5	15	μA
		$I_{OUT} = 100\text{ mA}$, $V_{OUT} = 1.2\text{ V}$		60		
I_{SHDN}	Shutdown supply current	$V_{EN} = 0.4\text{ V}$, $V_{IN} = 12\text{ V}$		0.59	5.0	μA
I_{FB}	Feedback current ⁽⁴⁾		-1	0.0	1	μA
I_{EN}	Enable current	$3\text{ V} \leq V_{IN} \leq 12\text{ V}$, $V_{IN} = V_{EN}$	-1	0.01	1	μA
V_{EN_HI}	Enable high-level voltage		1.2			V
V_{EN_LO}	Enable low-level voltage				0.3	V
V_{IT}	PG trip threshold	OUT pin floating, V_{FB} increasing, $V_{IN} \geq V_{IN_MIN}$	85		95	% V_{OUT}
		OUT pin floating, V_{FB} decreasing, $V_{IN} \geq V_{IN_MIN}$	83		93	
V_{HYS}	PG trip hysteresis			2.3		% V_{OUT}
V_{PG_LO}	PG output low voltage	OUT pin floating, $V_{FB} = 80\% V_{REF}$, $I_{PG} = 100\text{ }\mu\text{A}$			0.4	V
I_{PG_LKG}	PG leakage current	$V_{PG} = V_{OUT(NOM)}$	-1		1	μA
I_{DELAY}	DELAY pin current			1	2	μA
PSRR	Power-supply rejection ratio	$V_{IN} = 3\text{ V}$, $V_{OUT(NOM)} = V_{REF}$, $C_{OUT} = 10\text{ }\mu\text{F}$, $f = 100\text{ Hz}$		50		dB
T_{SD}	Thermal shutdown temperature	Shutdown, temperature increasing		175		$^\circ\text{C}$
		Reset, temperature decreasing		155		

- (1) Maximum input voltage is limited to 24 V because of the package power dissipation limitations at full load ($P \approx (V_{IN} - V_{OUT}) \times I_{OUT} = (24\text{ V} - V_{REF}) \times 50\text{ mA} \approx 1.14\text{ W}$). The device is capable of sourcing a maximum current of 50 mA at higher input voltages as long as the power dissipated is within the thermal limits of the package plus any external heatsinking.
- (2) For fixed output voltages only.
- (3) For adjustable output only, where $V_{OUT} = 1.2\text{ V}$
- (4) $I_{FB} > 0\text{ }\mu\text{A}$ flows out of the device.

6.6 Typical Characteristics

at $T_A = -40^\circ\text{C}$ to 125°C , $V_{IN} = V_{OUT(NOM)} + 0.5\text{ V}$ or $V_{IN} = 3\text{ V}$ (whichever is greater), $V_{EN} = V_{IN}$, $I_{OUT} = 10\ \mu\text{A}$, $C_{IN} = 1\ \mu\text{F}$, $C_{OUT} = 2.2\ \mu\text{F}$, and FB tied to OUT (unless otherwise noted)



图 1. Quiescent Current vs Input Voltage



图 2. Shutdown Current vs Input Voltage

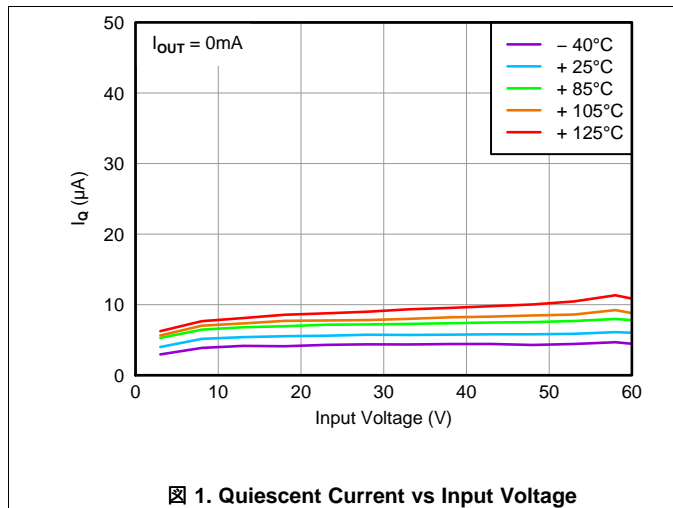

图 3. Quiescent Current vs Output Current

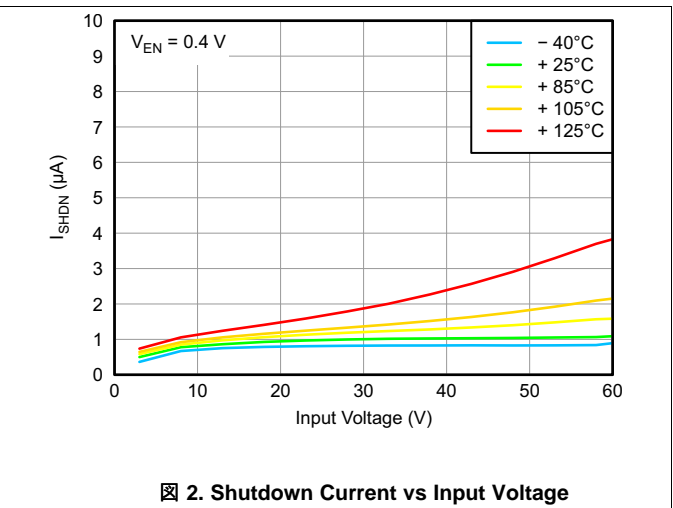

图 4. Dropout Voltage vs Output Current

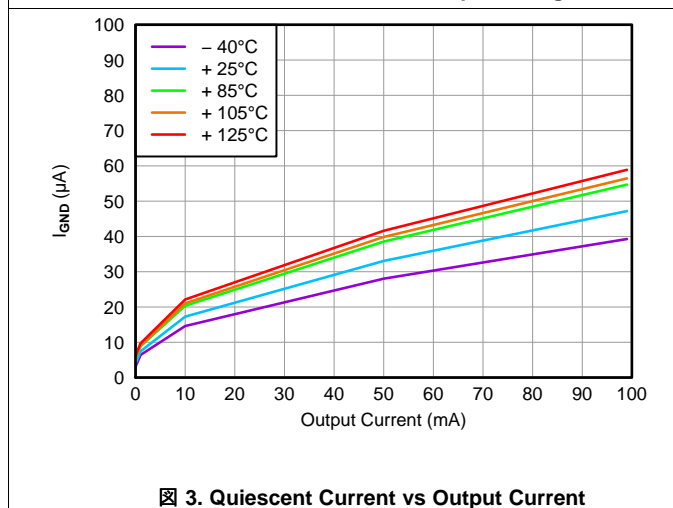

图 5. Feedback Voltage vs Input Voltage

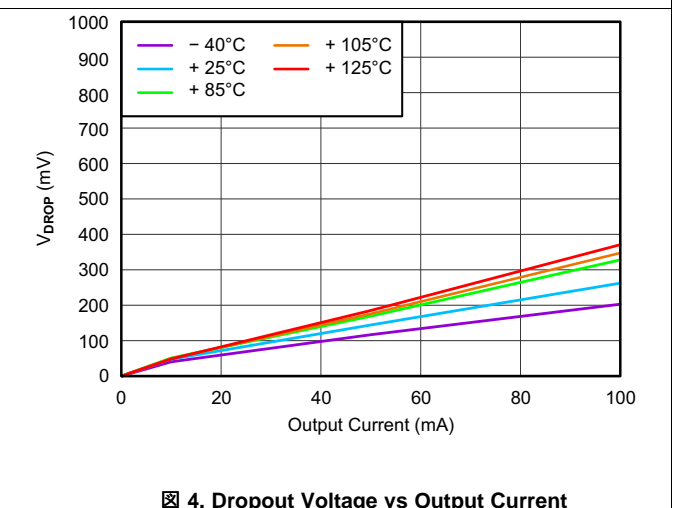

图 6. Line Regulation

Typical Characteristics (continued)

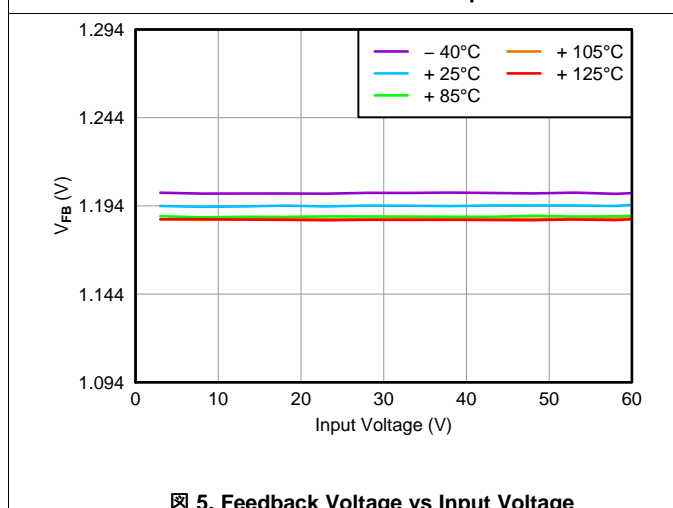
at $T_A = -40^{\circ}\text{C}$ to 125°C , $V_{IN} = V_{OUT(NOM)} + 0.5\text{ V}$ or $V_{IN} = 3\text{ V}$ (whichever is greater), $V_{EN} = V_{IN}$, $I_{OUT} = 10\ \mu\text{A}$, $C_{IN} = 1\ \mu\text{F}$, $C_{OUT} = 2.2\ \mu\text{F}$, and FB tied to OUT (unless otherwise noted)

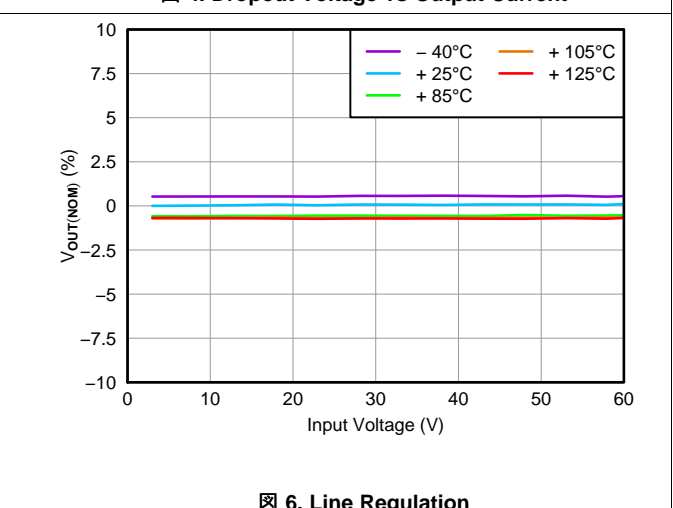
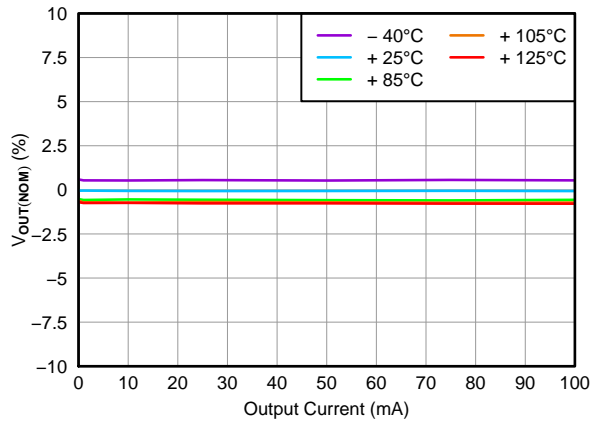

7. Load Regulation

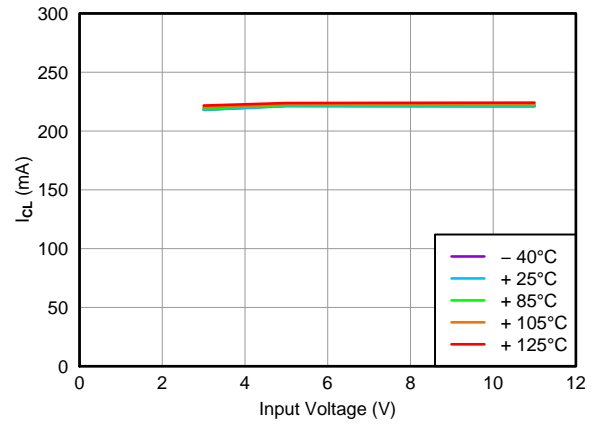

8. Current Limit vs Input Voltage

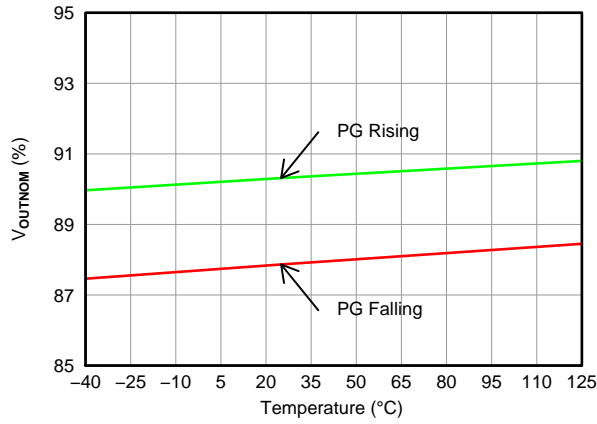

9. Power-Good Threshold Voltage vs Temperature

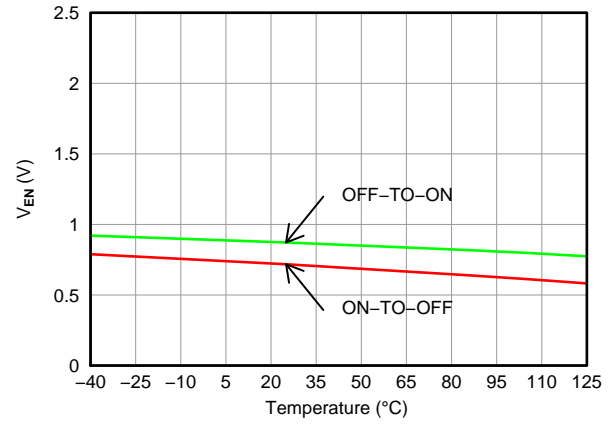

10. Enable Threshold Voltage vs Temperature

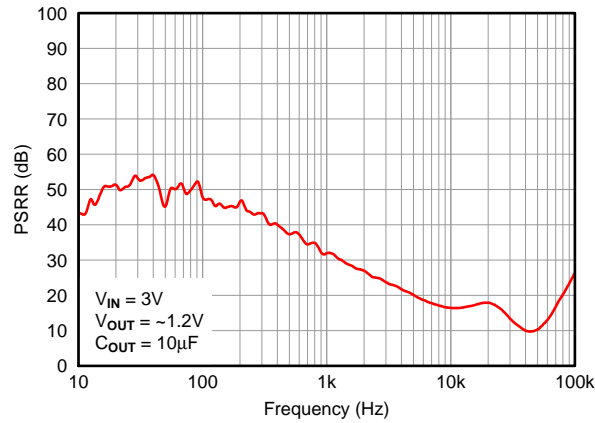

11. Power-Supply Rejection Ratio vs Frequency

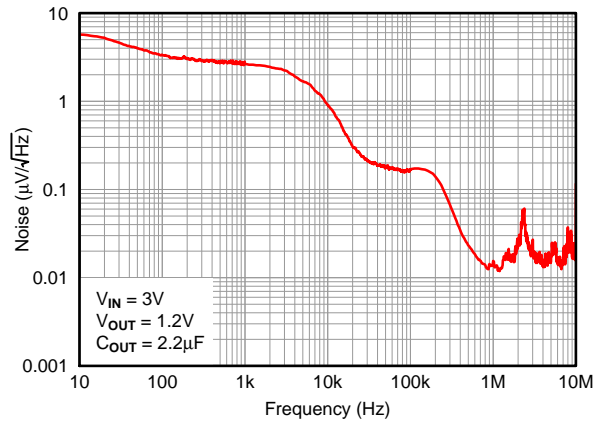

12. Output Spectral Noise Density

Typical Characteristics (continued)

at $T_A = -40^{\circ}\text{C}$ to 125°C , $V_{IN} = V_{OUT(NOM)} + 0.5\text{ V}$ or $V_{IN} = 3\text{ V}$ (whichever is greater), $V_{EN} = V_{IN}$, $I_{OUT} = 10\text{ }\mu\text{A}$, $C_{IN} = 1\text{ }\mu\text{F}$, $C_{OUT} = 2.2\text{ }\mu\text{F}$, and FB tied to OUT (unless otherwise noted)

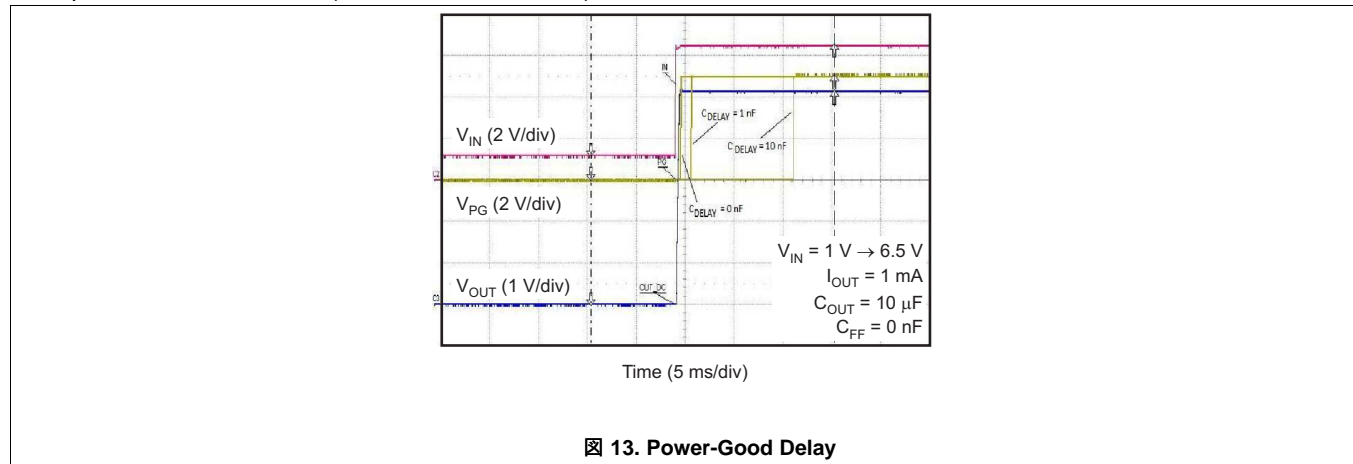

7 Detailed Description

7.1 Overview

The TPS7A16A-Q1 is an ultra-low-power, low-dropout (LDO) voltage regulator that offers the benefits of ultra-low quiescent current, high input voltage, and miniaturized, high thermal-performance packaging. The TPS7A16A-Q1 also offers an enable pin (EN) and an integrated open-drain, active-high, power-good output (PG) with a user-programmable delay.

7.2 Functional Block Diagram

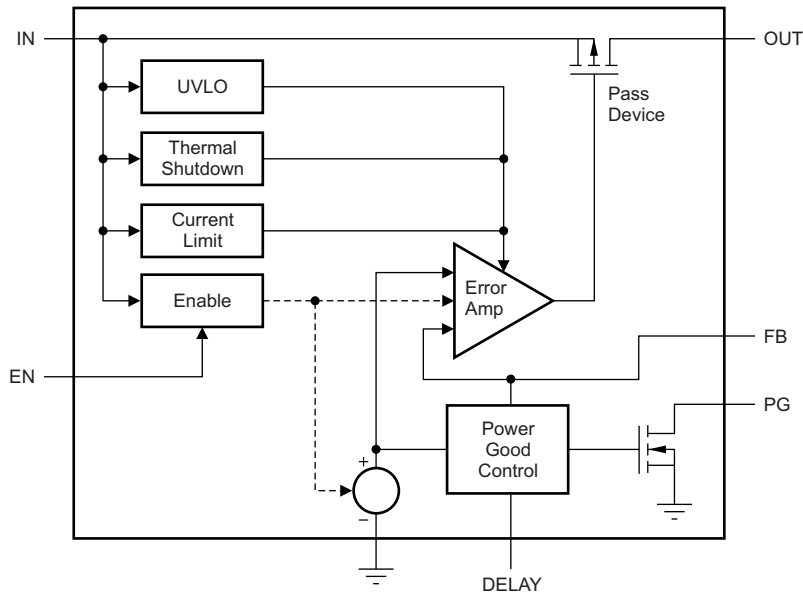

7.3 Feature Description

7.3.1 Enable (EN)

The enable pin is a high-voltage-tolerant pin. A high input on EN activates the device and turns on the regulator. For self-bias applications, connect this input to the IN pin. Ensure that $V_{EN} \leq V_{IN}$ at all times.

When the enable signal is comprised of pulse-width modulation (PWM) pulses, the slew rate of the rising and falling edges must be less than $1.5 \text{ V}/\mu\text{s}$. Adding a $0.1\text{-}\mu\text{F}$ capacitor from the EN pin to GND is recommended.

7.3.2 Regulated Output (V_{OUT})

The OUT pin is the regulated output based on the required voltage. The output has current limitation. During initial power up, the regulator has a soft-start incorporated to control the initial current through the pass element. In the event that the regulator drops out of regulation, the output tracks the input minus a drop based on the load current. When the input voltage drops below the undervoltage lockout (UVLO) threshold, the regulator shuts down until the input voltage recovers above the minimum start-up level.

7.3.3 PG Delay Timer (DELAY)

The power-good delay time (t_{DELAY}) is defined as the time period from when V_{OUT} exceeds the PG trip threshold voltage (V_{IT}) to when the PG output is high. This power-good delay time is set by an external capacitor (C_{DELAY}) connected from the DELAY pin to GND; this capacitor is charged from 0 V to approximately 1.8 V by the DELAY pin current (I_{DELAY}) when V_{OUT} exceeds the PG trip threshold (V_{IT}).

7.4 Device Functional Modes

7.4.1 Power-Good

The power-good (PG) pin is an open-drain output and can be connected to any 5.5-V or lower rail through an external pullup resistor. When no C_{DELAY} is used, the PG output is high-impedance when V_{OUT} is greater than the PG trip threshold (V_{IT}). If V_{OUT} drops below V_{IT} , the open-drain output turns on and pulls the PG output low. If output voltage monitoring is not needed, the PG pin can be left floating or connected to GND.

To ensure proper operation of the power-good feature, maintain $V_{\text{IN}} \geq 3 \text{ V}$ ($V_{\text{IN_MIN}}$).

7.4.1.1 Power-Good Delay and Delay Capacitor

The power-good delay time (t_{DELAY}) is defined as the time period from when V_{OUT} exceeds the PG trip threshold voltage (V_{IT}) to when the PG output is high. This power-good delay time is set by an external capacitor (C_{DELAY}) connected from the DELAY pin to GND; this capacitor is charged from 0 V to up to 1.8 V by the DELAY pin current (I_{DELAY}) once V_{OUT} exceeds the PG trip threshold (V_{IT}).

When C_{DELAY} is used, the PG output is high-impedance when V_{OUT} exceeds V_{IT} , and V_{DELAY} exceeds V_{REF} .

The power-good delay time can be calculated using: $t_{\text{DELAY}} = (C_{\text{DELAY}} \times V_{\text{REF}}) / I_{\text{DELAY}}$. For example, when $C_{\text{DELAY}} = 10 \text{ nF}$, the PG delay time is approximately 12 ms; that is, $(10 \text{ nF} \times 1.193 \text{ V}) / 1 \text{ }\mu\text{A} = 11.93 \text{ ms}$.

8 Application and Implementation

注

Information in the following applications sections is not part of the TI component specification, and TI does not warrant its accuracy or completeness. TI's customers are responsible for determining suitability of components for their purposes. Customers should validate and test their design implementation to confirm system functionality.

8.1 Application Information

The TPS7A16A-Q1 offers the benefit of ultra-low quiescent current, high input voltage, and miniaturized, high-thermal-performance packaging.

The TPS7A16A-Q1 is designed for continuous or sporadic (power backup) battery-operated applications where ultra-low quiescent current is critical to extending system battery life.

8.2 Typical Applications

8.2.1 TPS7A16A-Q1 Circuit as an Adjustable Regulator



图 14. The TPS7A16A-Q1 Circuit as an Adjustable Regulator Schematic

8.2.1.1 Design Requirements

表 1 lists the design parameters for this application.

表 1. Design Parameters

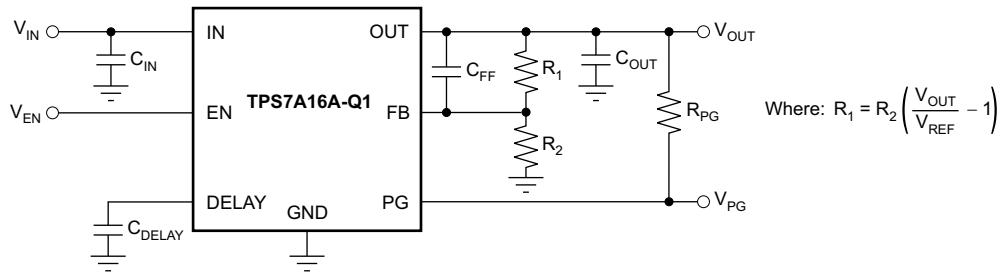
DESIGN PARAMETER	EXAMPLE VALUE
Input voltage range	5.5 V to 40 V
Output voltage	5 V
Output current rating	100 mA
Output capacitor range	2.2 μ F to 100 μ F
Delay capacitor range	100 pF to 100 nF

8.2.1.2 Detailed Design Procedure

8.2.1.2.1 Adjustable Voltage Operation

The TPS7A16A-Q1 has an output voltage range from 1.194 V to 20 V. As shown in 图 15, the nominal output of the device is set by two external resistors.



图 15. Adjustable Operation

式 1 can calculate R_1 and R_2 for any output voltage range:

$$R_1 = R_2 \left(\frac{V_{OUT}}{V_{REF}} - 1 \right) \quad (1)$$

8.2.1.2.1.1 Resistor Selection

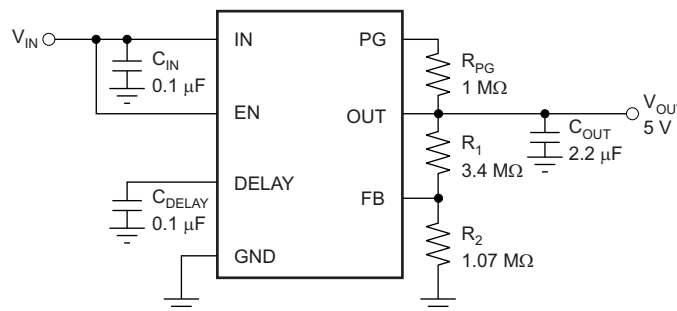
Use resistors in the order of $M\Omega$ to keep the overall quiescent current of the system as low as possible (by making the current used by the resistor divider negligible compared to the quiescent current of the device).

If greater voltage accuracy is required, take into account the voltage offset contributions as a result of feedback current and use 0.1% tolerance resistors.

表 2 shows the resistor combination to achieve an output for a few of the most common rails using commercially available 0.1% tolerance resistors to maximize nominal voltage accuracy, while adhering to the formula shown in 式 1.

表 2. Selected Resistor Combinations

V _{OUT}	R ₁	R ₂	V _{OUT} /(R ₁ + R ₂) « I _Q	NOMINAL ACCURACY
1.194 V	0 Ω	∞	0 μA	±2%
1.8 V	1.18 MΩ	2.32 MΩ	514 nA	±(2% + 0.14%)
2.5 V	1.5 MΩ	1.37 MΩ	871 nA	±(2% + 0.16%)
3.3 V	2 MΩ	1.13 MΩ	1056 nA	±(2% + 0.35%)
5 V	3.4 MΩ	1.07 MΩ	1115 nA	±(2% + 0.39%)
10 V	7.87 MΩ	1.07 MΩ	1115 nA	±(2% + 0.42%)
12 V	14.3 MΩ	1.58 MΩ	755 nA	±(2% + 0.18%)
15 V	42.2 MΩ	3.65 MΩ	327 nA	±(2% + 0.19%)
18 V	16.2 MΩ	1.15 MΩ	1038 nA	±(2% + 0.26%)

Close attention must be paid to board contamination when using high-value resistors; board contaminants can significantly impact voltage accuracy. If board cleaning measures cannot be ensured, consider using a fixed-voltage version of the TPS7A16A-Q1 or using resistors in the order of hundreds or tens of kΩ.

8.2.1.2.2 Capacitor Recommendations

Use low equivalent-series-resistance (ESR) capacitors for the input, output, and feed-forward capacitors. Ceramic capacitors with X7R and X5R dielectrics are preferred. These dielectrics offer more stable characteristics. Ceramic X7R capacitors offer improved overtemperature performance, but ceramic X5R capacitors are the most cost-effective and are available in higher values.

However, high-ESR capacitors can degrade PSRR.

8.2.1.2.3 Input and Output Capacitor Requirements

The TPS7A16A-Q1 ultra-low-power, high-voltage linear regulator achieves stability with a minimum input capacitance of 0.1 μF and output capacitance of 2.2 μF; however, TI recommends using a 10-μF ceramic capacitor to maximize ac performance.

8.2.1.2.4 Feed-Forward Capacitor (Only for Adjustable Version)

Although a feed-forward capacitor (C_{FF}) from OUT to FB is not needed to achieve stability, TI recommends using a 0.01-μF feed-forward capacitor to maximize ac performance.

8.2.1.2.5 Transient Response

As with any regulator, increasing the size of the output capacitor reduces over- and undershoot magnitude but increases the duration of the transient response.

8.2.1.3 Application Curves

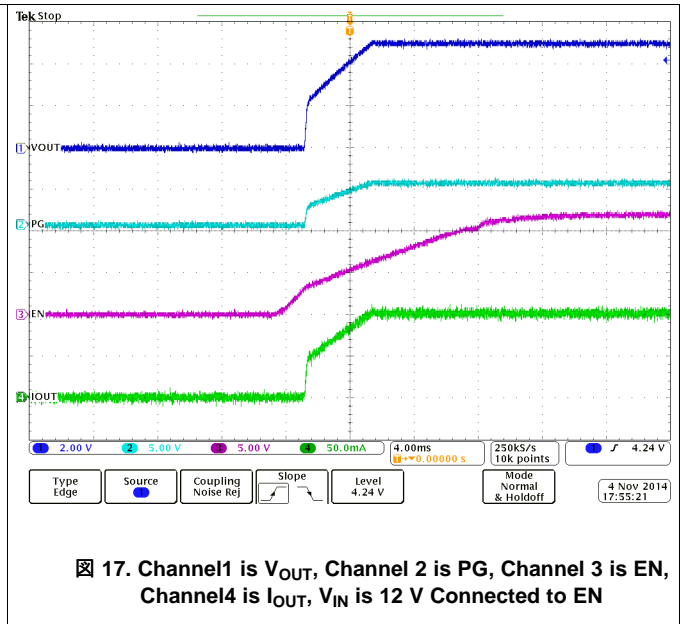
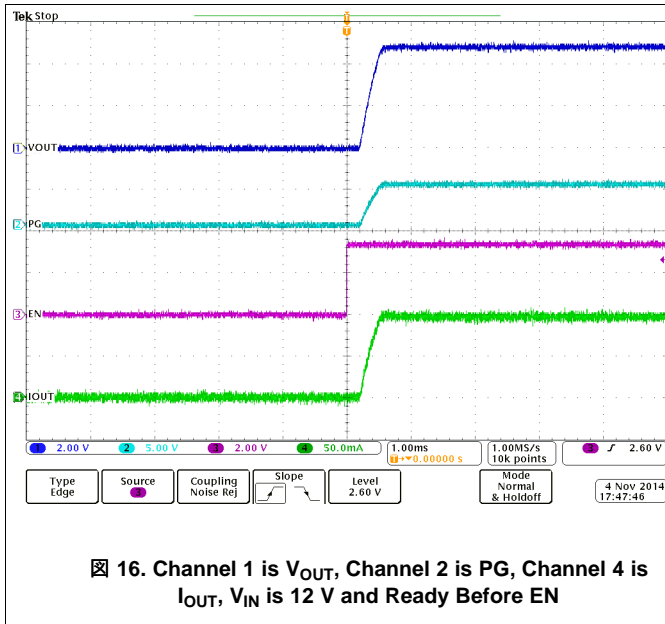

8.2.2 Automotive Applications

The TPS7A16A-Q1 maximum input voltage of 60 V makes the device ideal for use in automotive applications where high-voltage transients are present.

Events such as load-dump overvoltage (where the battery is disconnected while the alternator is providing current to a load) can cause voltage spikes from 25 V to 60 V. In order to prevent any damage to sensitive circuitry, local transient voltage suppressors can be used to cap voltage spikes to lower, more manageable voltages.

The TPS7A16A-Q1 can be used to simplify and lower costs in such cases. The very high voltage range allows this regulator not only to withstand the voltages coming out of these local transient voltage suppressors, but even replace them, thus lowering system cost and complexity. [Figure 18](#) shows a circuit diagram of an example automotive application.

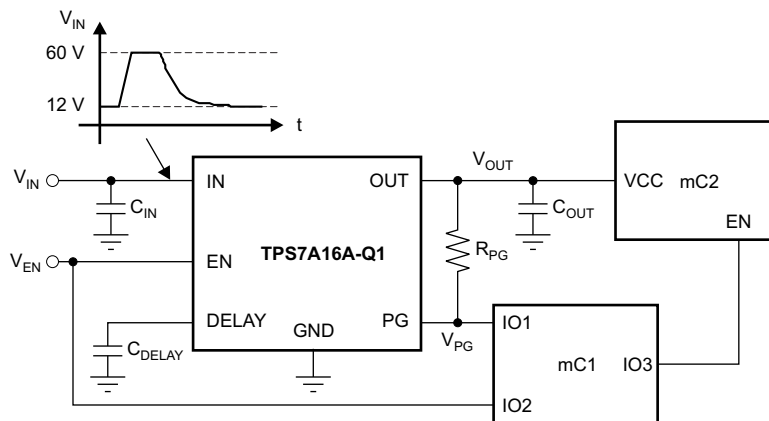

Figure 18. Low-Power Microcontroller Rail Sequencing in Automotive Applications Subjected to Load-Dump Transients

8.2.2.1 Design Requirements

[Table 3](#) lists the design parameters for this application.

Table 3. Design Parameters

DESIGN PARAMETER	EXAMPLE VALUE
Input voltage range	5.5 V to 60 V
Output voltage	5 V
Output current rating	100 mA
Output capacitor range	2.2 μ F to 100 μ F
Delay capacitor range	100 pF to 100 nF

8.2.2.2 Detailed Design Procedure

See the [Capacitor Recommendations](#) and [Input and Output Capacitor Requirements](#) sections.

8.2.2.2.1 Device Recommendations

The output is fixed, so choose the TPS7A16A-Q1.

8.2.2.3 Application Curves

See [Figure 16](#) and [Figure 17](#).

9 Power Supply Recommendations

Design of the device is for operation from an input voltage supply with a range between 3 V and 60 V. This input supply must be well regulated. The TPS7A16A-Q1 ultra-low-power, high-voltage linear regulator achieves stability with a minimum input capacitance of 0.1 μF and output capacitance of 2.2 μF ; however, TI recommends using a 10- μF ceramic capacitor to maximize AC performance.

10 Layout

10.1 Layout Guidelines

To improve ac performance such as PSRR, output noise, and transient response, the board is recommended to be designed with separate ground planes for IN and OUT, with each ground plane connected only at the GND pin of the device. This grounding scheme is commonly referred to as *star grounding*. In addition, directly connect the ground connection for the output capacitor to the GND pin of the device.

Equivalent series inductance (ESL) and ESR must be minimized in order to maximize performance and ensure stability. Every capacitor must be placed as close as possible to the device and on the same side of the PCB as the regulator itself.

Do not place any of the capacitors on the opposite side of the PCB from where the regulator is installed. The use of vias and long traces is strongly discouraged because they can impact system performance negatively and even cause instability.

If possible, and to ensure the maximum performance denoted in this document, use the same layout pattern used for the TPS7A16A-Q1 evaluation board, available at www.ti.com.

Layout is a critical part of good power-supply design. There are several signal paths that conduct fast-changing currents or voltages that can interact with stray inductance or parasitic capacitance to generate noise or degrade the power-supply performance. To help eliminate these problems, bypass the IN pin to ground with a low-ESR ceramic bypass capacitor with X5R or X7R dielectric.

Acceptable performance can be obtained with alternative PCB layouts; however, the layout and the schematic have been shown to produce good results and are meant as a guideline.

✖ 19 illustrates the schematic for the suggested layout. ✖ 20 and ✖ 21 depict the top and bottom printed circuit board (PCB) layers for the suggested layout, respectively.

10.1.1 Additional Layout Considerations

The high impedance of the FB pin makes the regulator sensitive to parasitic capacitances that can couple undesirable signals from nearby components (especially from logic and digital devices, such as microcontrollers and microprocessors); these capacitively-coupled signals can produce undesirable output voltage transients. In these cases, use a fixed-voltage version of the TPS7A16A-Q1, or isolate the FB node by flooding the local PCB area with ground-plane copper to minimize any undesirable signal coupling.

10.1.2 Power Dissipation

The ability to remove heat from the die is different for each package type, presenting different considerations in the PCB layout. The PCB area around the device that is free of other components moves the heat from the device to the ambient air. Using heavier copper increases the effectiveness of removing heat from the device. The addition of plated through-holes to heat dissipating layers also improves the heatsink effectiveness.

Power dissipation depends on input voltage and load conditions. As 式 2 shows, power dissipation (P_D) is equal to the product of the output current times the voltage drop across the output pass element:

$$P_D = (V_{IN} - V_{OUT}) I_{OUT} \quad (2)$$

Layout Guidelines (continued)

10.1.3 Thermal Considerations

Thermal protection disables the output when the junction temperature rises to approximately 170°C, allowing the device to cool. When the junction temperature cools to approximately 150°C, the output circuitry is enabled. Depending on power dissipation, thermal resistance, and ambient temperature, the thermal protection circuit may cycle on and off. This cycling limits the dissipation of the regulator, protecting the regulator from damage as a result of overheating.

Any tendency to activate the thermal protection circuit indicates excessive power dissipation or an inadequate heat-spreading area. For reliable operation, limit junction temperature to a maximum of 125°C at the worst-case ambient temperature for a given application. To estimate the margin of safety in a complete design (including the copper heat-spreading area), increase the ambient temperature until the thermal protection is triggered; use worst-case loads and signal conditions. For good reliability, trigger thermal protection at least 45°C above the maximum expected ambient condition of the particular application. This configuration produces a worst-case junction temperature of 125°C at the highest expected ambient temperature and worst-case load.

The internal protection circuitry of the TPS7A16A-Q1 is designed to protect against overload conditions. This circuitry is not intended to replace proper heatsinking. Continuously running the TPS7A16A-Q1 into thermal shutdown degrades device reliability.

10.2 Layout Examples

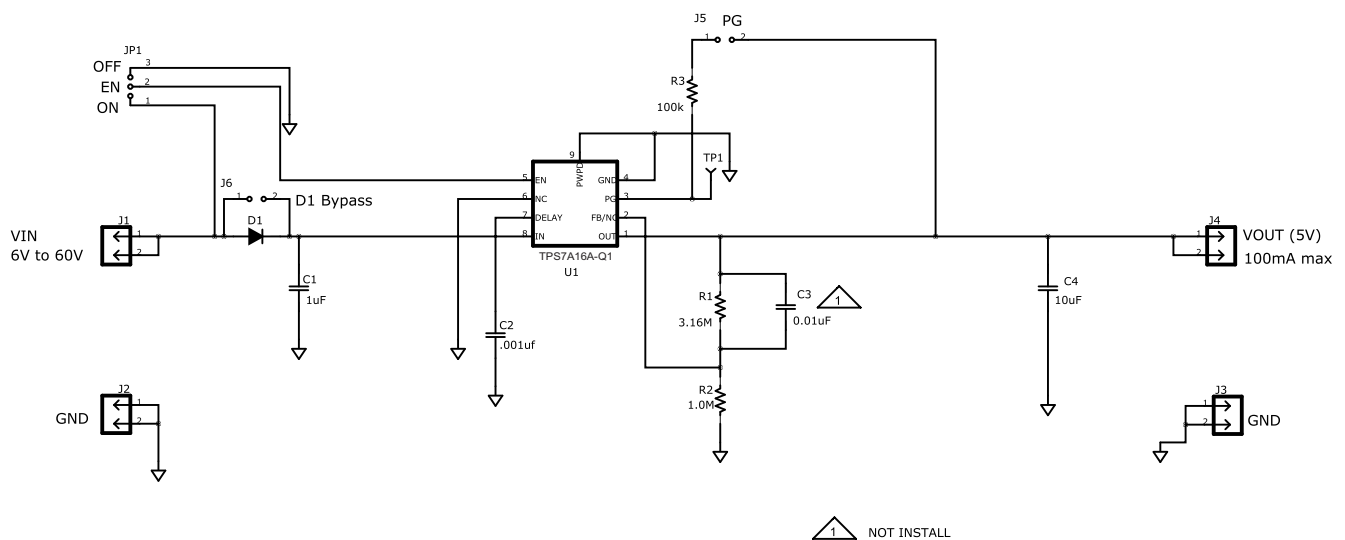

19. Schematic for Suggested Layout

Layout Examples (continued)



图 20. Suggested Layout: Top Layer



图 21. Suggested Layout: Bottom Layer

11 デバイスおよびドキュメントのサポート

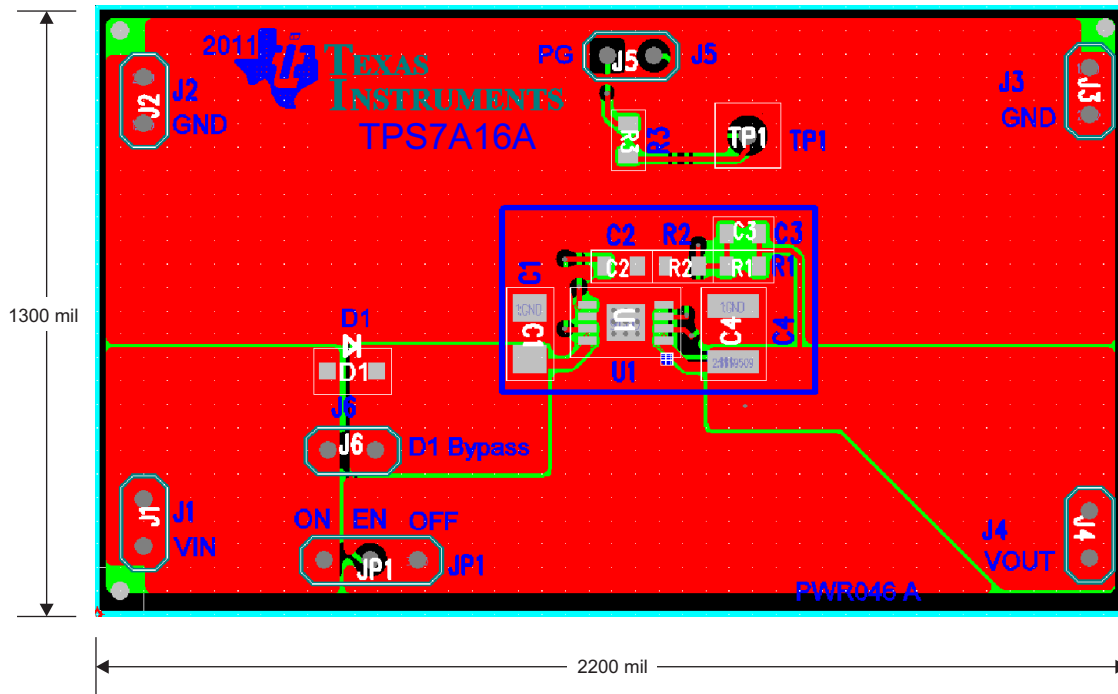
11.1 ドキュメントの更新通知を受け取る方法

ドキュメントの更新についての通知を受け取るには、ti.comのデバイス製品フォルダを開いてください。右上の「アラートを受け取る」をクリックして登録すると、変更されたすべての製品情報に関するダイジェストを毎週受け取れます。変更の詳細については、修正されたドキュメントに含まれている改訂履歴をご覧ください。

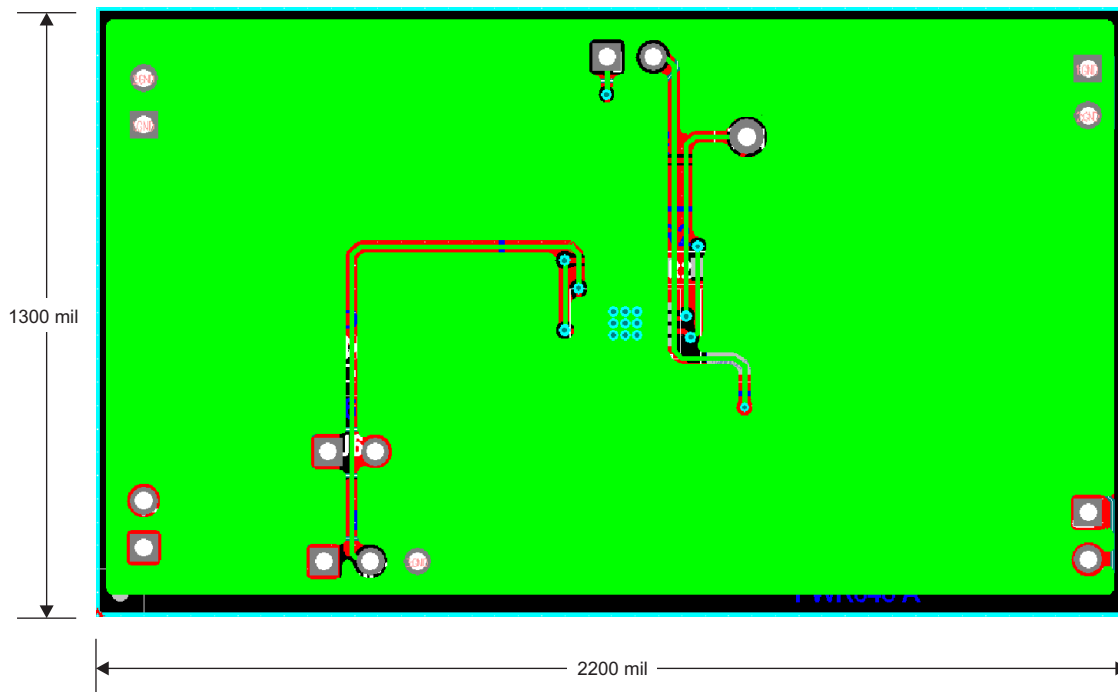
11.2 コミュニティ・リソース

The following links connect to TI community resources. Linked contents are provided "AS IS" by the respective contributors. They do not constitute TI specifications and do not necessarily reflect TI's views; see TI's [Terms of Use](#).

TI E2E™ Online Community *TI's Engineer-to-Engineer (E2E) Community*. Created to foster collaboration among engineers. At e2e.ti.com, you can ask questions, share knowledge, explore ideas and help solve problems with fellow engineers.

Design Support *TI's Design Support* Quickly find helpful E2E forums along with design support tools and contact information for technical support.

11.3 商標

PowerPAD, E2E are trademarks of Texas Instruments.
All other trademarks are the property of their respective owners.

11.4 静電気放電に関する注意事項



すべての集積回路は、適切なESD保護方法を用いて、取扱いと保存を行うようにして下さい。

静電気放電はわずかな性能の低下から完全なデバイスの故障に至るまで、様々な損傷を与えます。高精度の集積回路は、損傷に対して敏感であり、極めてわずかなパラメータの変化により、デバイスに規定された仕様に適合しなくなる場合があります。

11.5 Glossary

SLYZ022 — *TI Glossary*.

This glossary lists and explains terms, acronyms, and definitions.

12 メカニカル、パッケージ、および注文情報

以降のページには、メカニカル、パッケージ、および注文に関する情報が記載されています。この情報は、そのデバイスについて利用可能な最新のデータです。このデータは予告なく変更されることがあり、ドキュメントが改訂される場合もあります。本データシートのブラウザ版を使用されている場合は、画面左側の説明をご覧ください。

PACKAGING INFORMATION

Orderable Device	Status (1)	Package Type	Package Drawing	Pins	Package Qty	Eco Plan (2)	Lead finish/ Ball material (6)	MSL Peak Temp (3)	Op Temp (°C)	Device Marking (4/5)	Samples
TPS7A1601AQDGNRQ1	ACTIVE	HVSSOP	DGN	8	2500	RoHS & Green	NIPDAU	Level-2-260C-1 YEAR	-40 to 125	1NT1	Samples
TPS7A1633AQDGNRQ1	ACTIVE	HVSSOP	DGN	8	2500	RoHS & Green	NIPDAU	Level-2-260C-1 YEAR	-40 to 125	1NU1	Samples
TPS7A1650AQDGNRQ1	ACTIVE	HVSSOP	DGN	8	2500	RoHS & Green	NIPDAU	Level-2-260C-1 YEAR	-40 to 125	1NV1	Samples

(1) The marketing status values are defined as follows:

ACTIVE: Product device recommended for new designs.

LIFEBUY: TI has announced that the device will be discontinued, and a lifetime-buy period is in effect.

NRND: Not recommended for new designs. Device is in production to support existing customers, but TI does not recommend using this part in a new design.

PREVIEW: Device has been announced but is not in production. Samples may or may not be available.

OBSELETE: TI has discontinued the production of the device.

(2) **RoHS:** TI defines "RoHS" to mean semiconductor products that are compliant with the current EU RoHS requirements for all 10 RoHS substances, including the requirement that RoHS substance do not exceed 0.1% by weight in homogeneous materials. Where designed to be soldered at high temperatures, "RoHS" products are suitable for use in specified lead-free processes. TI may reference these types of products as "Pb-Free".

RoHS Exempt: TI defines "RoHS Exempt" to mean products that contain lead but are compliant with EU RoHS pursuant to a specific EU RoHS exemption.

Green: TI defines "Green" to mean the content of Chlorine (Cl) and Bromine (Br) based flame retardants meet JS709B low halogen requirements of <=1000ppm threshold. Antimony trioxide based flame retardants must also meet the <=1000ppm threshold requirement.

(3) MSL, Peak Temp. - The Moisture Sensitivity Level rating according to the JEDEC industry standard classifications, and peak solder temperature.

(4) There may be additional marking, which relates to the logo, the lot trace code information, or the environmental category on the device.

(5) Multiple Device Markings will be inside parentheses. Only one Device Marking contained in parentheses and separated by a "~" will appear on a device. If a line is indented then it is a continuation of the previous line and the two combined represent the entire Device Marking for that device.

(6) Lead finish/Ball material - Orderable Devices may have multiple material finish options. Finish options are separated by a vertical ruled line. Lead finish/Ball material values may wrap to two lines if the finish value exceeds the maximum column width.

Important Information and Disclaimer:The information provided on this page represents TI's knowledge and belief as of the date that it is provided. TI bases its knowledge and belief on information provided by third parties, and makes no representation or warranty as to the accuracy of such information. Efforts are underway to better integrate information from third parties. TI has taken and continues to take reasonable steps to provide representative and accurate information but may not have conducted destructive testing or chemical analysis on incoming materials and chemicals. TI and TI suppliers consider certain information to be proprietary, and thus CAS numbers and other limited information may not be available for release.

In no event shall TI's liability arising out of such information exceed the total purchase price of the TI part(s) at issue in this document sold by TI to Customer on an annual basis.

TAPE AND REEL INFORMATION



QUADRANT ASSIGNMENTS FOR PIN 1 ORIENTATION IN TAPE



*All dimensions are nominal

Device	Package Type	Package Drawing	Pins	SPQ	Reel Diameter (mm)	Reel Width W1 (mm)	A0 (mm)	B0 (mm)	K0 (mm)	P1 (mm)	W (mm)	Pin1 Quadrant
TPS7A1601AQDGNRQ1	HVSSOP	DGN	8	2500	330.0	12.4	5.3	3.3	1.3	8.0	12.0	Q1
TPS7A1633AQDGNRQ1	HVSSOP	DGN	8	2500	330.0	12.4	5.3	3.3	1.3	8.0	12.0	Q1
TPS7A1650AQDGNRQ1	HVSSOP	DGN	8	2500	330.0	12.4	5.3	3.3	1.3	8.0	12.0	Q1

TAPE AND REEL BOX DIMENSIONS

*All dimensions are nominal

Device	Package Type	Package Drawing	Pins	SPQ	Length (mm)	Width (mm)	Height (mm)
TPS7A1601AQDGNRQ1	HVSSOP	DGN	8	2500	367.0	367.0	38.0
TPS7A1633AQDGNRQ1	HVSSOP	DGN	8	2500	367.0	367.0	38.0
TPS7A1650AQDGNRQ1	HVSSOP	DGN	8	2500	367.0	367.0	38.0

GENERIC PACKAGE VIEW

DGN 8

PowerPAD™ HVSSOP - 1.1 mm max height

3 x 3, 0.65 mm pitch

SMALL OUTLINE PACKAGE

This image is a representation of the package family, actual package may vary.
Refer to the product data sheet for package details.

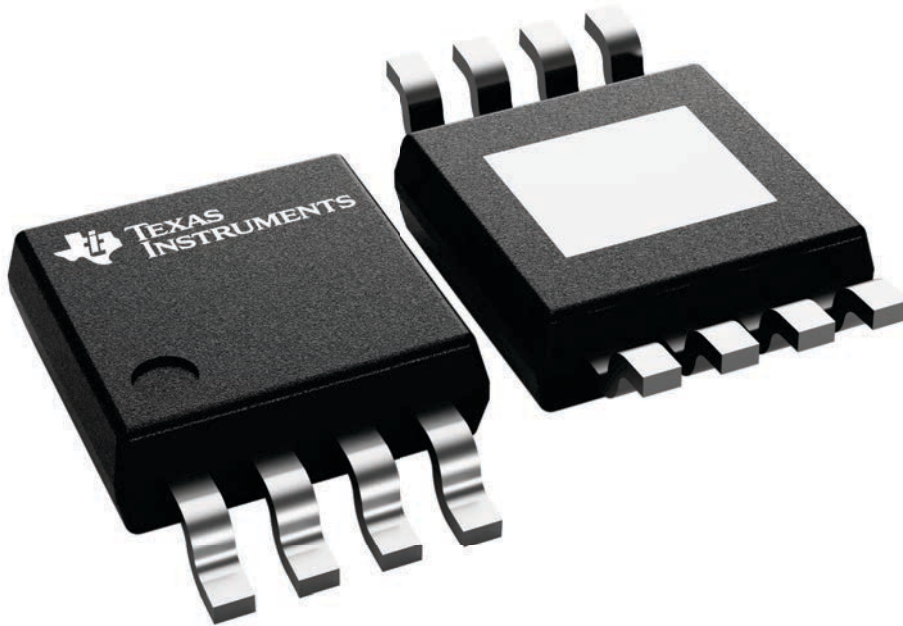

4225482/B

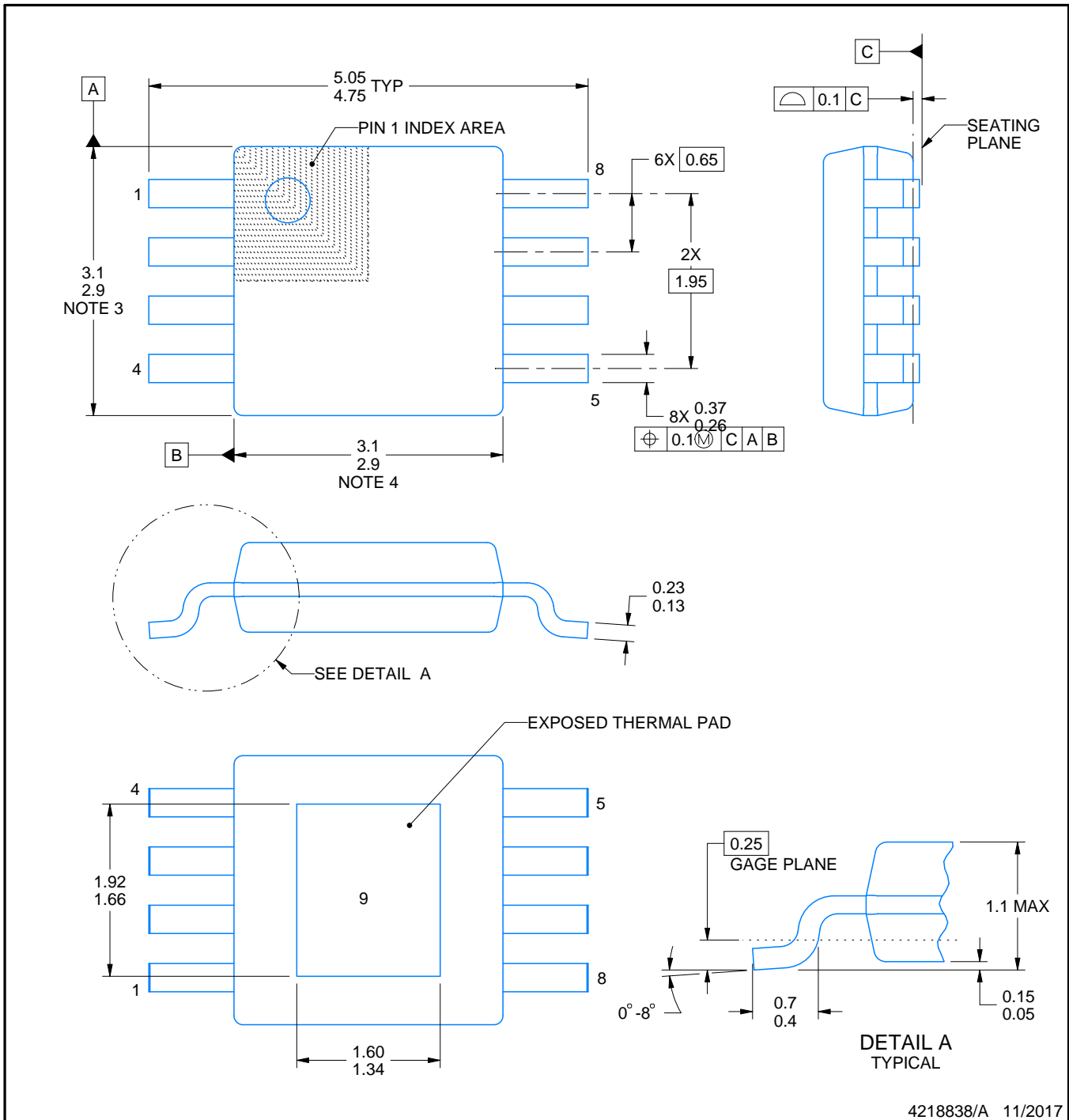
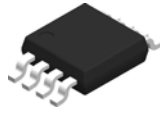

4218838/A 11/2017

NOTES:

1. All linear dimensions are in millimeters. Any dimensions in parenthesis are for reference only. Dimensioning and tolerancing per ASME Y14.5M.
2. This drawing is subject to change without notice.
3. This dimension does not include mold flash, protrusions, or gate burrs. Mold flash, protrusions, or gate burrs shall not exceed 0.15 mm per side.
4. This dimension does not include interlead flash. Interlead flash shall not exceed 0.25 mm per side.
5. Reference JEDEC registration MO-187.

EXAMPLE BOARD LAYOUT

DGN0008C

HVSSOP - 1.1 mm max height

SMALL OUTLINE PACKAGE

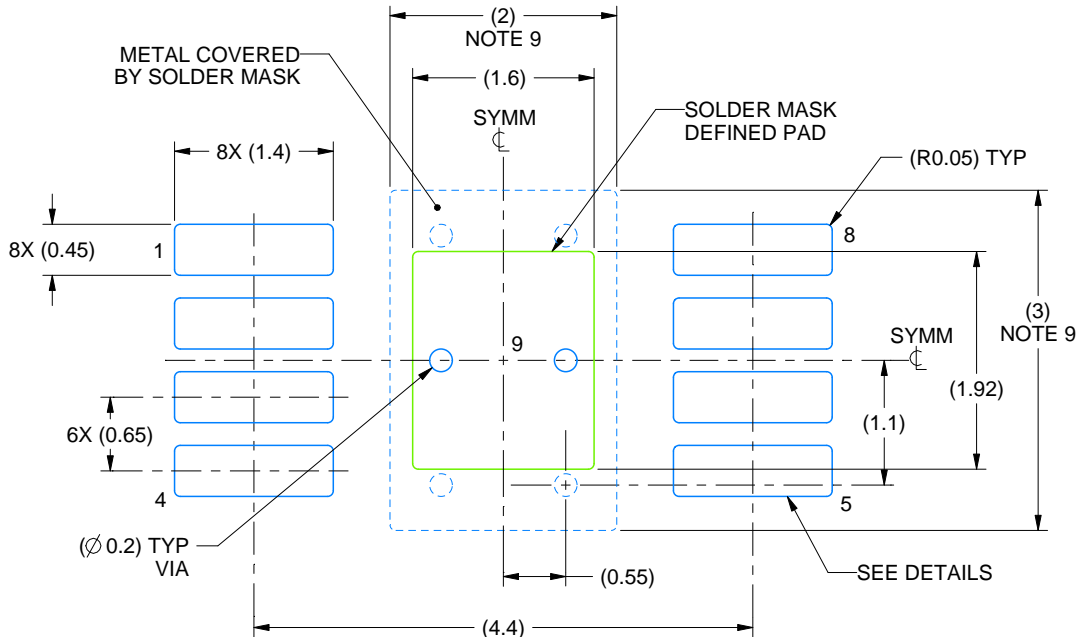

LAND PATTERN EXAMPLE
EXPOSED METAL SHOWN
SCALE: 15X



4218838/A 11/2017

NOTES: (continued)

6. Publication IPC-7351 may have alternate designs.
7. Solder mask tolerances between and around signal pads can vary based on board fabrication site.
8. Vias are optional depending on application, refer to device data sheet. If any vias are implemented, refer to their locations shown on this view. It is recommended that vias under paste be filled, plugged or tented.
9. Size of metal pad may vary due to creepage requirement.

EXAMPLE STENCIL DESIGN

DGN0008C

HVSSOP - 1.1 mm max height

SMALL OUTLINE PACKAGE

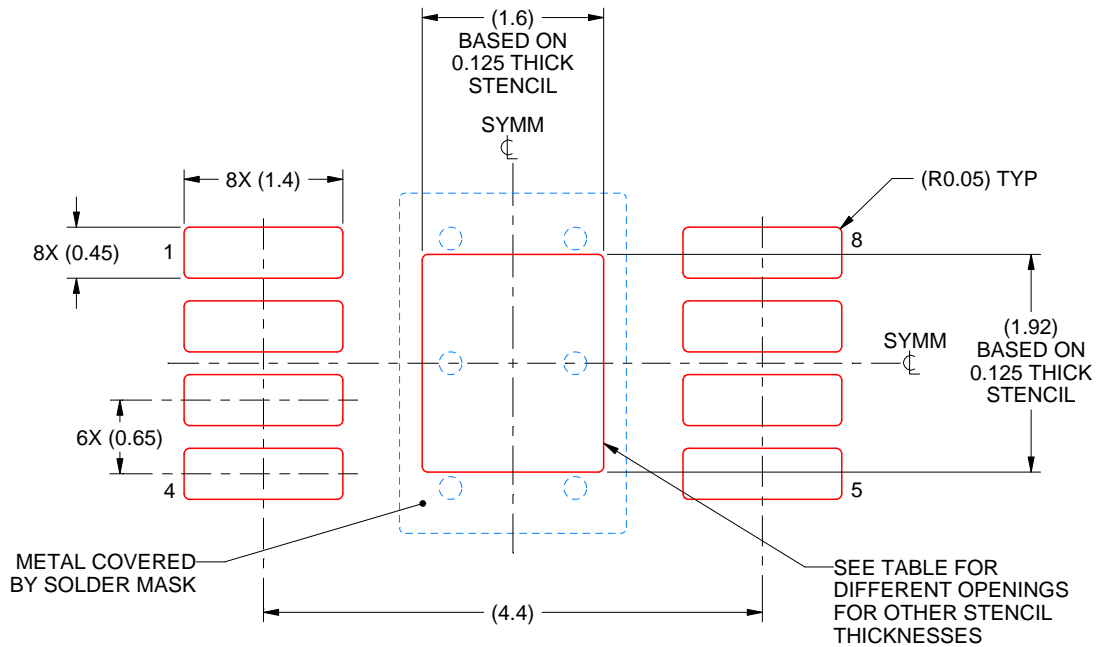

SOLDER PASTE EXAMPLE
 EXPOSED PAD 9:
 100% PRINTED SOLDER COVERAGE BY AREA
 SCALE: 15X

STENCIL THICKNESS	SOLDER STENCIL OPENING
0.1	1.79 X 2.15
0.125	1.60 X 1.92 (SHOWN)
0.15	1.46 X 1.75
0.175	1.35 X 1.62

4218838/A 11/2017

NOTES: (continued)

10. Laser cutting apertures with trapezoidal walls and rounded corners may offer better paste release. IPC-7525 may have alternate design recommendations.
11. Board assembly site may have different recommendations for stencil design.

重要なお知らせと免責事項

TI は、技術データと信頼性データ(データシートを含みます)、設計リソース(リファレンス・デザインを含みます)、アプリケーションや設計に関する各種アドバイス、Web ツール、安全性情報、その他のリソースを、欠陥が存在する可能性のある「現状のまま」提供しており、商品性および特定目的に対する適合性の黙示保証、第三者の知的財産権の非侵害保証を含むいかなる保証も、明示的または黙示的にかかわらず拒否します。

これらのリソースは、TI 製品を使用する設計の経験を積んだ開発者への提供を意図したものです。(1) お客様のアプリケーションに適した TI 製品の選定、(2) お客様のアプリケーションの設計、検証、試験、(3) お客様のアプリケーションに該当する各種規格や、その他のあらゆる安全性、セキュリティ、規制、または他の要件への確実な適合に関する責任を、お客様のみが単独で負うものとします。

上記の各種リソースは、予告なく変更される可能性があります。これらのリソースは、リソースで説明されている TI 製品を使用するアプリケーションの開発の目的でのみ、TI はその使用をお客様に許諾します。これらのリソースに関して、他の目的で複製することや掲載することは禁止されています。TI や第三者の知的財産権のライセンスが付与されている訳ではありません。お客様は、これらのリソースを自身で使用した結果発生するあらゆる申し立て、損害、費用、損失、責任について、TI およびその代理人を完全に補償するものとし、TI は一切の責任を拒否します。

TI の製品は、[TI の販売条件](#)、または [ti.com](#) やかかる TI 製品の関連資料などのいずれかを通じて提供する適用可能な条項の下で提供されています。TI がこれらのリソースを提供することは、適用される TI の保証または他の保証の放棄の拡大や変更を意味するものではありません。

お客様がいかなる追加条項または代替条項を提案した場合でも、TI はそれらに異議を唱え、拒否します。

郵送先住所 : Texas Instruments, Post Office Box 655303, Dallas, Texas 75265
Copyright © 2024, Texas Instruments Incorporated