

# TPS92610-Q1 車載シングルチャネル・リニアLEDドライバ

## 1 特長

- 車載アプリケーションに対応
- 下記内容でAEC-Q100認定済み：
  - 温度グレード1: 動作時周囲温度範囲  $-40^{\circ}\text{C} \sim 125^{\circ}\text{C}$
  - デバイスHBM ESD分類レベルH2
  - デバイスCDM ESD分類レベルC3B
- 機能安全対応
  - 機能安全システムの設計に役立つ資料を利用可能
- PWM調光機能付きシングルチャネル定電流LEDドライバ
- 広い入力電圧範囲:  $4.5\text{V} \sim 40\text{V}$
- 定出力電流、センス抵抗により調整可能
- 高精度の電流レギュレーション、接合部温度範囲  $-40^{\circ}\text{C} \sim 150^{\circ}\text{C}$  で許容誤差  $\pm 4.6\%$
- 最大電流:  $450\text{mA}$
- 外付け抵抗との熱共有
- 低ドロップアウト電圧(センス抵抗での電圧降下を含む)
  - 最大ドロップアウト:  $150\text{mV}$  ( $10\text{mA}$ 時)
  - 最大ドロップアウト:  $400\text{mV}$  ( $70\text{mA}$ 時)
  - 最大ドロップアウト:  $700\text{mV}$  ( $150\text{mA}$ 時)
  - 最大ドロップアウト:  $1.3\text{V}$  ( $300\text{mA}$ 時)
- 診断および保護
  - シングルLED短絡検出と自動回復
  - LED開路および短絡検出と自動回復
  - 診断イネーブルと可変スレッシュホールドによる低ドロップアウト動作
  - 最大15個のデバイスのフォルト・バス、どれか1つに障害が発生すれば全体を障害とするか、障害の発生したチャンネルのみをオフにするかを選択可能
  - 静止電流およびフォルトモード電流が低い(デバイスあたり $250\mu\text{A}$ 未満)
- 動作時の接合部温度範囲:  $-40^{\circ}\text{C} \sim 150^{\circ}\text{C}$

## 2 アプリケーション

- 車載補助照明: ドーム型ライト、ドアハンドル、読書灯、その他のランプ
- 車載リアランプ、センター・ハイマウント・ストップ・ランプ、サイドマーカ、死角検出インジケータ、充電インレット・インジケータ
- 汎用LEDドライバ・アプリケーション

## 3 概要

LEDが車載アプリケーションに広く使われているなか、シンプルなLEDドライバの人気の高まっています。ディスクリート・ソリューションに比べて、低コストのモノリシック・ソリューションではシステム・レベルの部品数を減らし、電流の精度や信頼性を大幅に高めることができます。

TPS92610-Q1デバイスは、自動車用バッテリーで動作する、シンプルなシングルチャネルのハイサイドLEDドライバです。シンプルで洗練されたソリューションにより、1本のLEDストリングに定電流を供給し、完全なLED診断を実行できます。どれか1つに障害が発生すれば全体を障害とする機能は、TPS9261x-Q1、TPS9263x-Q1、TPS9283x-Q1といった他のLEDドライバとの連係が可能であるため、さまざまな要求に対応できます。

### 製品情報<sup>(1)</sup>

型番	パッケージ	本体サイズ(公称)
TPS92610-Q1	HTSSOP (14)	5mmx4.4mm

(1) 提供されているすべてのパッケージについては、巻末の注文情報を参照してください。

### 代表的なアプリケーションの図

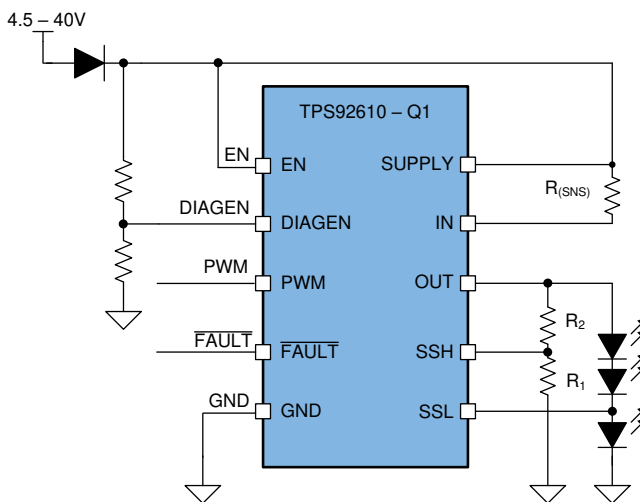

Copyright © 2017, Texas Instruments Incorporated

## 目次

1	特長 .....	1	7.3	Feature Description .....	10
2	アプリケーション .....	1	7.4	Device Functional Modes .....	14
3	概要 .....	1	<b>8</b>	<b>Application and Implementation .....</b>	<b>16</b>
4	改訂履歴 .....	2	8.1	Application Information .....	16
5	<b>Pin Configuration and Functions .....</b>	<b>3</b>	8.2	Typical Application .....	16
6	<b>Specifications .....</b>	<b>3</b>	<b>9</b>	<b>Layout .....</b>	<b>21</b>
6.1	Absolute Maximum Ratings .....	3	9.1	Layout Guidelines .....	21
6.2	ESD Ratings .....	4	9.2	Layout Example .....	21
6.3	Recommended Operating Conditions .....	4	<b>10</b>	<b>デバイスおよびドキュメントのサポート .....</b>	<b>22</b>
6.4	Thermal Information .....	4	10.1	ドキュメントのサポート .....	22
6.5	Electrical Characteristics .....	4	10.2	ドキュメントの更新通知を受け取る方法 .....	22
6.6	Timing Requirements .....	6	10.3	コミュニティ・リソース .....	22
6.7	Typical Characteristics .....	7	10.4	商標 .....	22
<b>7</b>	<b>Detailed Description .....</b>	<b>10</b>	10.5	静電気放電に関する注意事項 .....	22
7.1	Overview .....	10	10.6	Glossary .....	22
7.2	Functional Block Diagram .....	10	<b>11</b>	<b>メカニカル、パッケージ、および注文情報 .....</b>	<b>23</b>

## 4 改訂履歴

### Revision A (December 2017) から Revision B に変更

**Page**

- 「[特長](#)」セクションに機能安全対応のリンクを追加 .....

**1**

### 2017年11月発行のものから更新

**Page**

- データシートを「事前情報」から「量産データ」に変更 .....

**1**

## 5 Pin Configuration and Functions

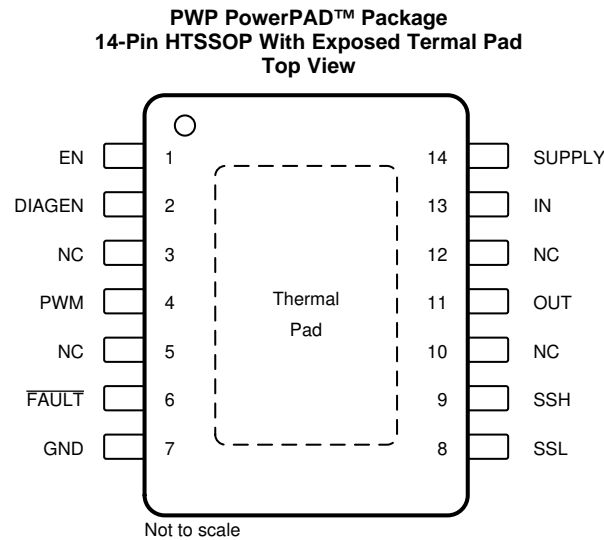

NC – No internal connection

### Pin Functions

PIN		I/O	DESCRIPTION
NAME	NO.		
DIAGEN	2	I	Diagnostics enable, to avoid false open-circuit diagnostics during low-voltage operation
EN	1	I	Device enable
$\overline{\text{FAULT}}$	6	I/O	One-fails–all-fail fault bus
GND	7	—	Ground
IN	13	I	Current input
NC	3, 5, 10, 12	—	Not connected
OUT	11	O	Constant-current output
PWM	4	I	PWM input
SSH	9	I	Single-LED short high-side reference
SSL	8	I	Single-LED short low-side reference
SUPPLY	14	I	Device supply voltage

## 6 Specifications

### 6.1 Absolute Maximum Ratings

over operating ambient temperature range (unless otherwise noted)<sup>(1)</sup>

		MIN	MAX	UNIT
High-voltage input	DIAGEN, EN, IN, PWM, SSH, SSL, SUPPLY	–0.3	45	V
High-voltage output	OUT	–0.3	45	V
Fault bus	$\overline{\text{FAULT}}$	–0.3	22	V
IN to OUT	$V_{(\text{IN})} - V_{(\text{OUT})}$	–0.3	45	V
SUPPLY to IN	$V_{(\text{SUPPLY})} - V_{(\text{IN})}$	–0.3	1	V
Operating junction temperature, $T_J$		–40	150	°C
Storage temperature, $T_{\text{stg}}$		–40	150	°C

(1) Stresses beyond those listed under *Absolute Maximum Ratings* may cause permanent damage to the device. These are stress ratings only, which do not imply functional operation of the device at these or any other conditions beyond those indicated under *Recommended Operating Conditions*. Exposure to absolute-maximum-rated conditions for extended periods may affect device reliability.

## 6.2 ESD Ratings

TPS92610-Q1			VALUE	UNIT
$V_{(ESD)}$ Electrostatic discharge	Human-body model (HBM), per AEC Q100-002 <sup>(1)</sup>	All pins	±2000	V
	Charged-device model (CDM), per AEC Q100-011	All pins	±500	
		Corner pins (1, 7, 8, and 14)	±750	

(1) AEC Q100-002 indicates that HBM stressing shall be in accordance with the ANSI/ESDA/JEDEC JS-001 specification.

## 6.3 Recommended Operating Conditions

over operating ambient temperature range (unless otherwise noted)

		MIN	NOM	MAX	UNIT
SUPPLY	Device supply voltage	4.5		40	V
IN	Sense voltage	4.4		40	V
PWM	PWM input	0		40	V
DIAGEN	Diagnostics enable pin	0		40	V
OUT	Driver output	0		40	V
SSH	Single LED short high-side reference	0		5	V
SSL	Single LED short low-side reference	0		5	V
EN	Device enable	0		40	V
$\overline{\text{FAULT}}$	Fault bus	0		7	V
$T_A$	Operating ambient temperature	-40		125	°C

## 6.4 Thermal Information

THERMAL METRIC <sup>(1)</sup>		TPS92610-Q1	UNIT
		PWP (HTSSOP)	
		14 PINS	
$R_{\theta JA}$	Junction-to-ambient thermal resistance	52.4	°C/W
$R_{\theta JC(top)}$	Junction-to-case (top) thermal resistance	43.5	°C/W
$R_{\theta JB}$	Junction-to-board thermal resistance	22	°C/W
$\Psi_{JT}$	Junction-to-top characterization parameter	1.6	°C/W
$\Psi_{JB}$	Junction-to-board characterization parameter	22.3	°C/W
$R_{\theta JC(bot)}$	Junction-to-case (bottom) thermal resistance	6.5	°C/W

(1) For more information about traditional and new thermal metrics, see [Semiconductor and IC Package Thermal Metrics](#).

## 6.5 Electrical Characteristics

$V_{(SUPPLY)} = 5\text{ V} - 40\text{ V}$ ,  $T_J = -40^\circ\text{C} - 150^\circ\text{C}$  unless otherwise noted

PARAMETER	TEST CONDITIONS	MIN	TYP	MAX	UNIT	
<b>BIAS</b>						
$V_{(POR\_rising)}$	Supply voltage POR rising threshold		3.2	4	V	
$V_{(POR\_falling)}$	Supply voltage POR falling threshold	2.2	3		V	
$I_{(Shutdown)}$	Device shutdown current	EN = LOW	5	10	μA	
$I_{(Quiescent)}$	Device quiescent current	PWM = HIGH, EN = HIGH	0.1	0.2	0.25	mA
$I_{(FAULT)}$	Device current in fault mode	EN = HIGH, PWM = HIGH, $\overline{\text{FAULT}}$ externally pulled LOW	0.1	0.2	0.25	mA

**Electrical Characteristics (continued)**
 $V_{(SUPPLY)} = 5\text{ V} - 40\text{ V}$ ,  $T_J = -40^\circ\text{C} - 150^\circ\text{C}$  unless otherwise noted

PARAMETER		TEST CONDITIONS	MIN	TYP	MAX	UNIT
<b>LOGIC INPUTS (DIAGEN, PWM, EN)</b>						
$V_{IL(DIAGEN)}$	Input logic-low voltage, DIAGEN		1.045	1.1	1.155	V
$V_{IH(DIAGEN)}$	Input logic-high voltage, DIAGEN		1.14	1.2	1.26	V
$V_{IL(PWM)}$	Input logic-low voltage, PWM		1.045	1.1	1.155	V
$V_{IH(PWM)}$	Input logic-high voltage, PWM		1.14	1.2	1.26	V
$V_{IL(EN)}$	Input logic-low voltage, EN				0.7	V
$V_{IH(EN)}$	Input logic-high voltage, EN		2			V
$I_{PD(EN)}$	EN pin pulldown current	$V_{(EN)} = 12\text{ V}$	1.5	3.3	4.5	$\mu\text{A}$
<b>CONSTANT-CURRENT DRIVER</b>						
$I_{(OUT)}$	Device output-current range	100% duty-cycle	4		450	mA
$V_{(CS\_REG)}$	Sense-resistor regulation voltage	$T_A = 25^\circ\text{C}$ , $V_{(SUPPLY)} = 4.5\text{ V to }18\text{ V}$	94	98	102	mV
		$T_A = -40^\circ\text{C to }125^\circ\text{C}$ , $V_{(SUPPLY)} = 4.5\text{ V to }18\text{ V}$	93.5	98	102.5	
$R_{(SNS)}$	Sense-resistor range				24.5	$\Omega$
$V_{(DROPOUT)}$	Voltage dropout from SUPPLY to OUT	$V_{(CS\_REG)}$ voltage included, current setting = 10 mA		120	150	mV
		$V_{(CS\_REG)}$ voltage included, current setting = 70 mA		250	400	
		$V_{(CS\_REG)}$ voltage included, current setting = 150 mA		430	700	
		$V_{(CS\_REG)}$ voltage included, current setting = 300 mA		800	1300	
<b>DIAGNOSTICS</b>						
$V_{(OPEN\_th\_rising)}$	LED open rising threshold, $V_{(IN)} - V_{(OUT)}$		70	100	135	mV
$V_{(OPEN\_th\_falling)}$	LED open falling threshold, $V_{(IN)} - V_{(OUT)}$		235	290	335	mV
$V_{(SG\_th\_falling)}$	Channel output $V_{(OUT)}$ short-to-ground falling threshold		1.14	1.2	1.26	V
$V_{(SG\_th\_rising)}$	Channel output $V_{(OUT)}$ short-to-ground rising threshold		0.82	0.865	0.91	V
$I_{(Retry)}$	Channel output retry current	$V_{(OUT)} = 0\text{ V}$	0.64	1.08	1.528	mA
$V_{(SSH\_th)}$	Single-LED short-detection high-side threshold	$V_{(SSL)} - V_{(SSH)}$	140	190	235	mV
$V_{(SSL\_th)}$	Single-LED short-detection low-side threshold		0.8	0.86	0.91	V
<b>FAULT</b>						
$V_{IL(FAULT)}$	Logic-input low threshold				0.7	V
$V_{IH(FAULT)}$	Logic-input high threshold		2			V
$V_{OL(FAULT)}$	Logic-output low voltage	With 500- $\mu\text{A}$ external pullup			0.4	V
$V_{OH(FAULT)}$	Logic-output high voltage	With 1- $\mu\text{A}$ external pulldown, $V_{(SUPPLY)} = 12\text{ V}$	5		7	V
$I_{(FAULT\_pulldown)}$	$\overline{\text{FAULT}}$ internal pulldown current		500	750	1000	$\mu\text{A}$
$I_{(FAULT\_pullup)}$	$\overline{\text{FAULT}}$ internal pullup current		5	8	12	$\mu\text{A}$
<b>THERMAL PROTECTION</b>						
$T_{(TSD)}$	Thermal shutdown junction temperature threshold		167	172	178	$^\circ\text{C}$
$T_{(TSD\_HYS)}$	Thermal shutdown junction temperature hysteresis			15		$^\circ\text{C}$

### 6.6 Timing Requirements

		MIN	NOM	MAX	UNIT
$t_{(PWM\_delay\_rising)}$	PWM rising edge delay, 50% PWM voltage to 10% of output current, $t_2 - t_1$ as shown in <a href="#">Fig 1</a>	10	17	25	$\mu s$
$t_{(PWM\_delay\_falling)}$	PWM falling edge delay, 50% PWM voltage to 90% of output current, $t_5 - t_4$ as shown in <a href="#">Fig 1</a>	15	21	30	$\mu s$
$t_{(TSD\_deg)}$	Thermal overtemperature deglitch time		60		$\mu s$
$t_{(DEVICE\_STARTUP)}$	EN rising edge to 10% output current at 150-mA set current and 12-V supply voltage		100	150	$\mu s$
$t_{(OPEN\_deg)}$	LED open-circuit fault-deglitch time	80	125	175	$\mu s$
$t_{(SG\_deg)}$	Channel-output short-to-ground detection deglitch time	80	125	175	$\mu s$
$t_{(SS\_deg)}$	Single-LED short-detection deglitch time	80	125	175	$\mu s$
$t_{(Recover\_deg)}$	Recovery deglitch time		16		$\mu s$

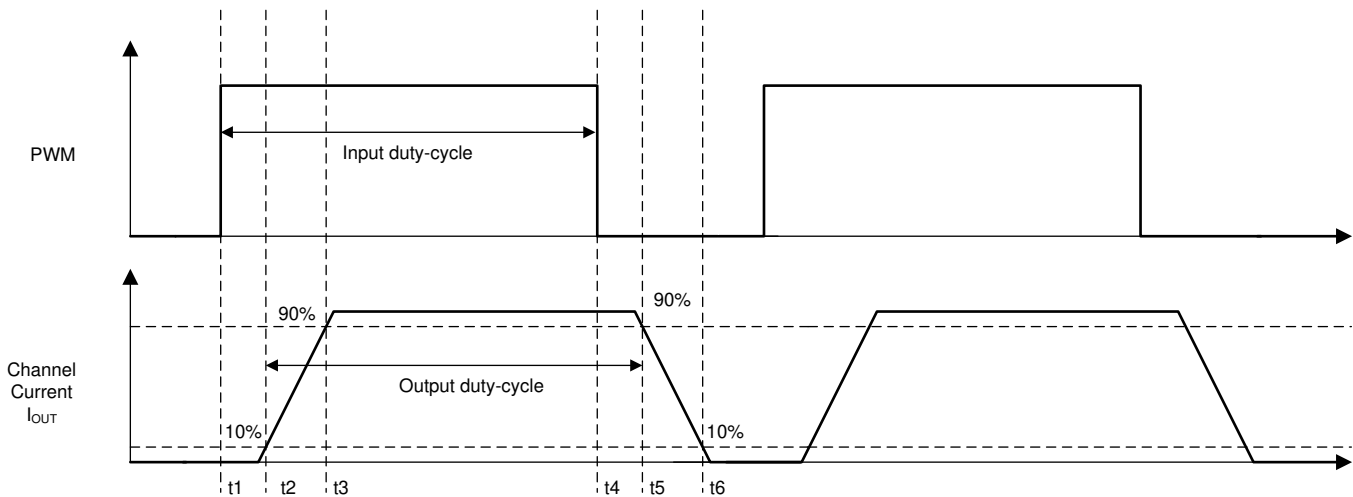

Copyright © 2017, Texas Instruments Incorporated

**Fig 1. Output Timing Diagram**

### 6.7 Typical Characteristics

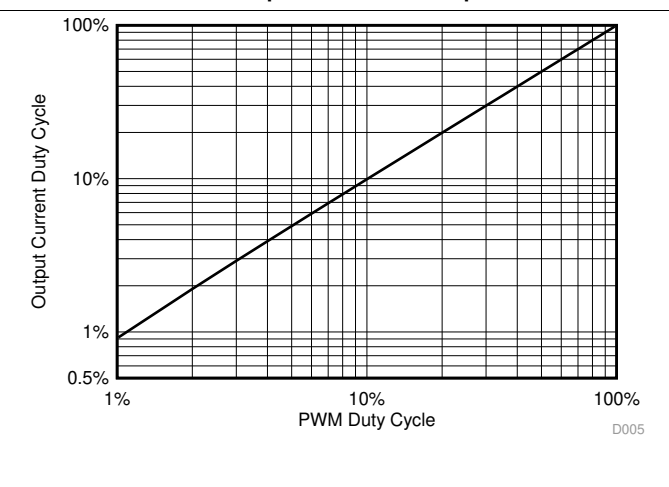
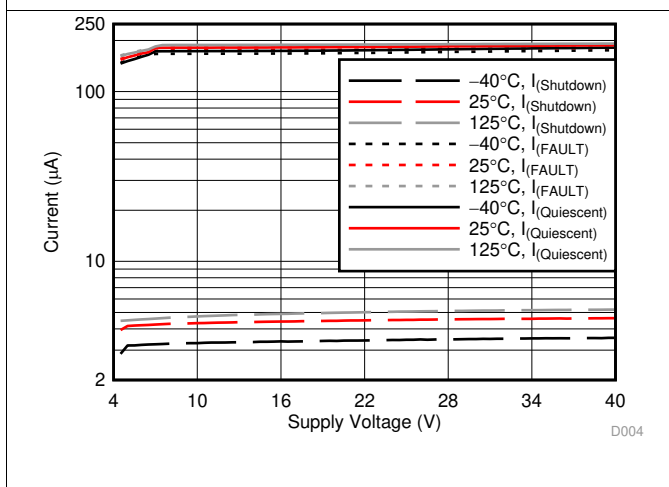
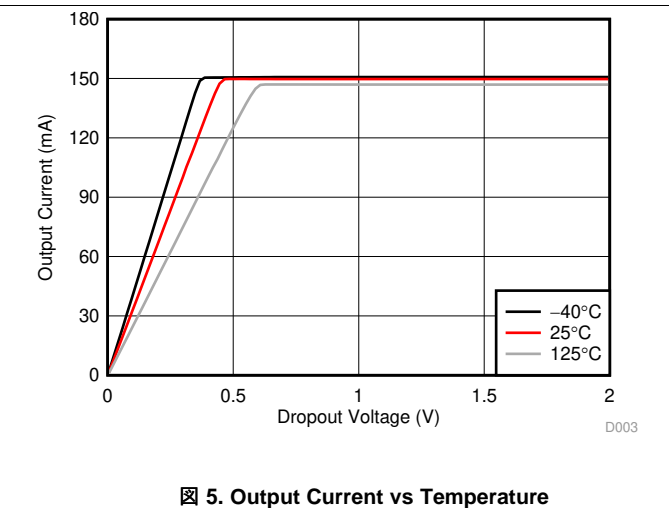
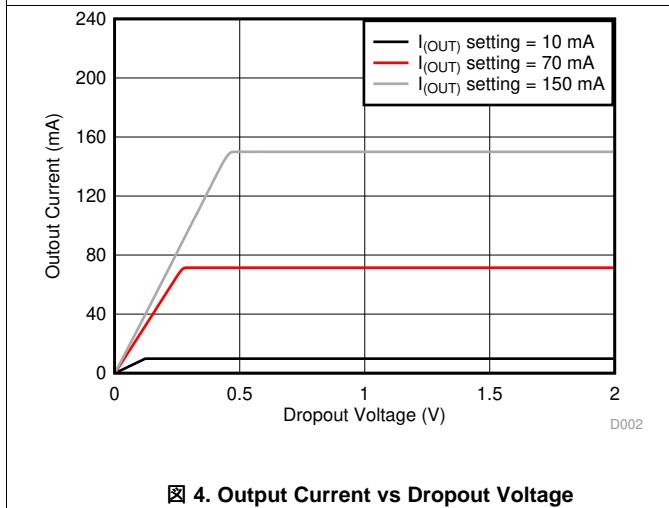
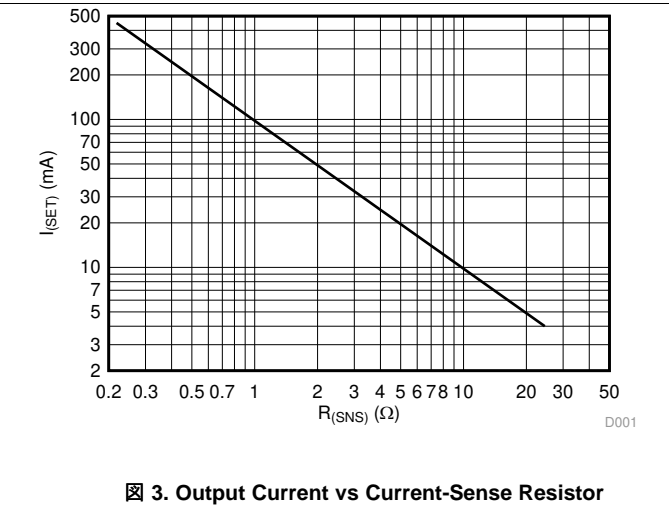
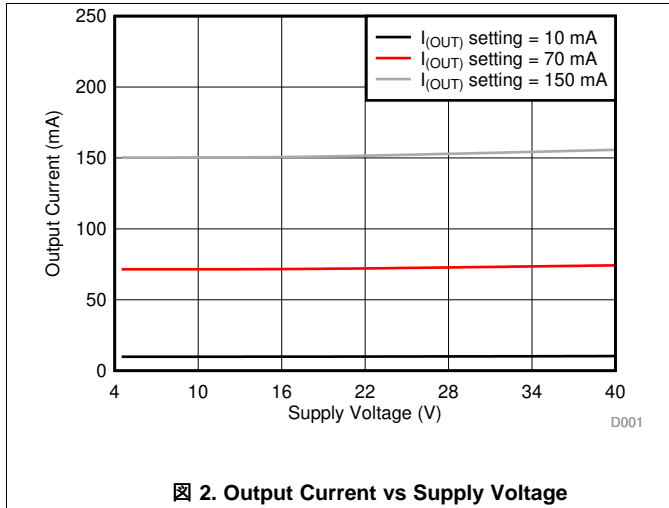

Typical Characteristics (continued)



图 8. PWM Dimming via External Input



图 9. PWM Dimming via Power Supply

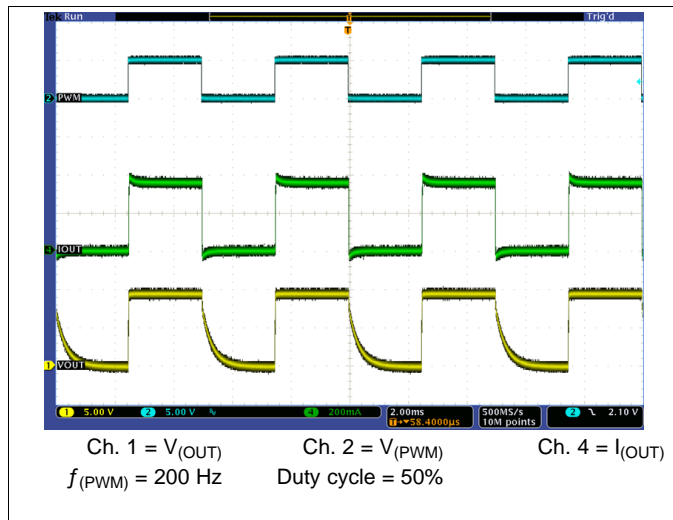

图 10. Transient Undervoltage

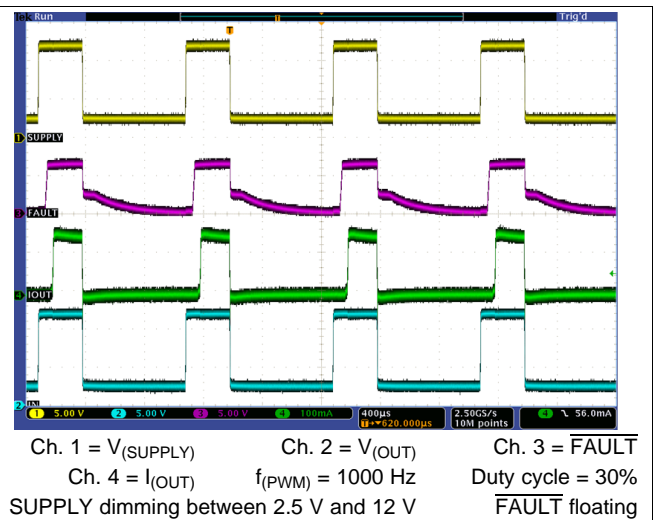

图 11. Transient Overvoltage

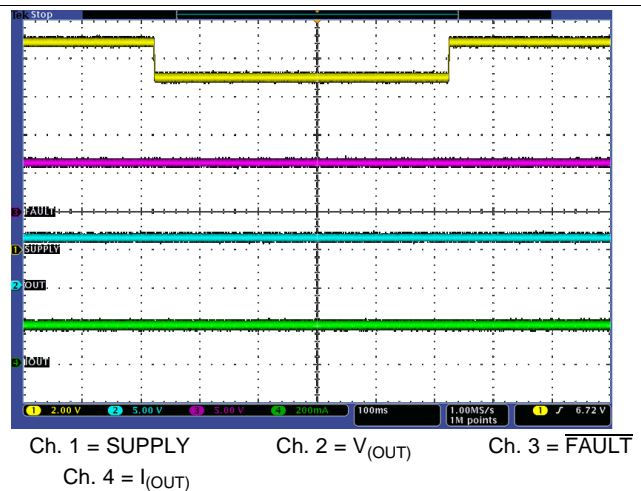

图 12. Jump Start

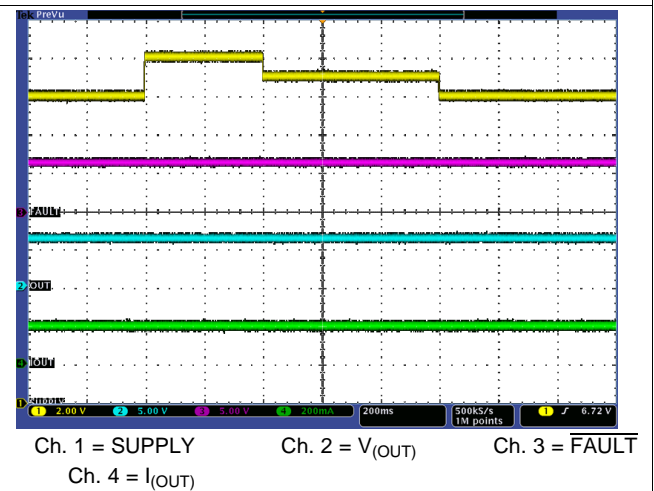

图 13. Superimposed Alternating Voltage, 15 Hz

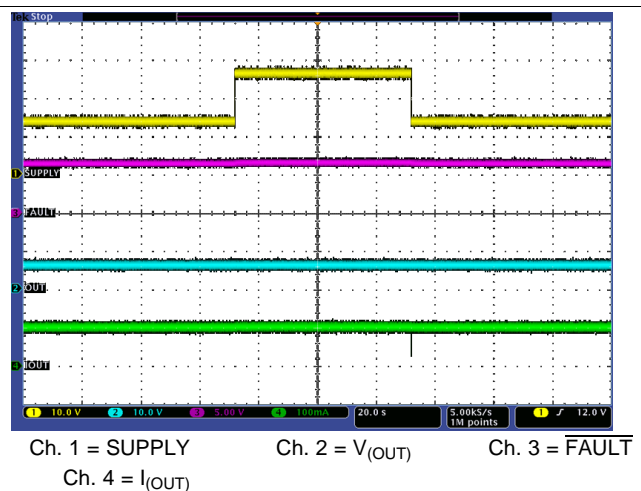

Typical Characteristics (continued)

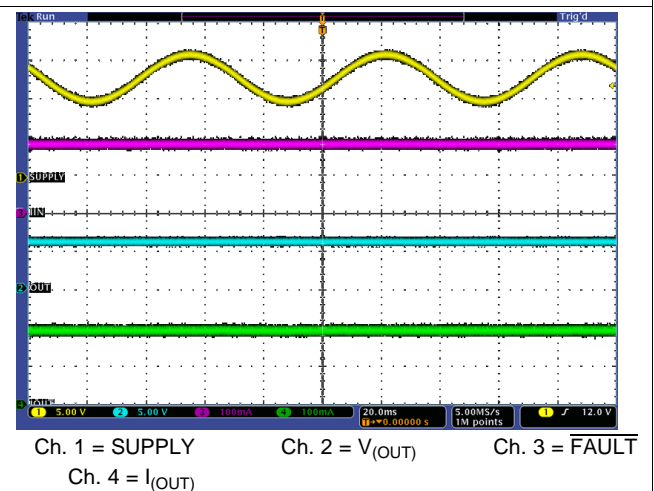
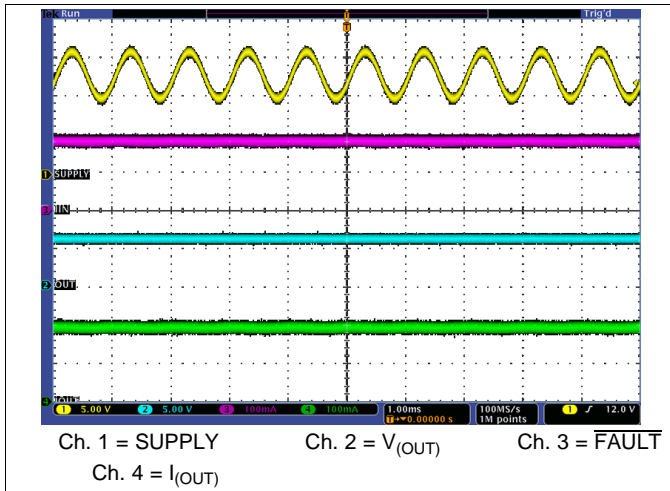

Figure 14. Superimposed Alternating Voltage, 1 kHz

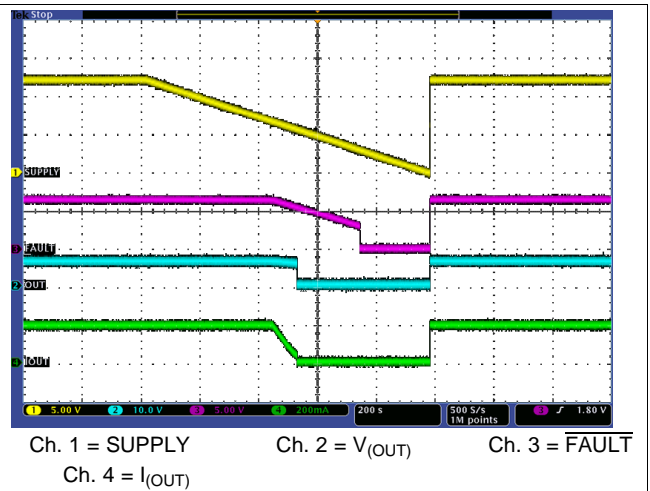

Figure 15. Slow Decrease, Quick Increase of Supply Voltage

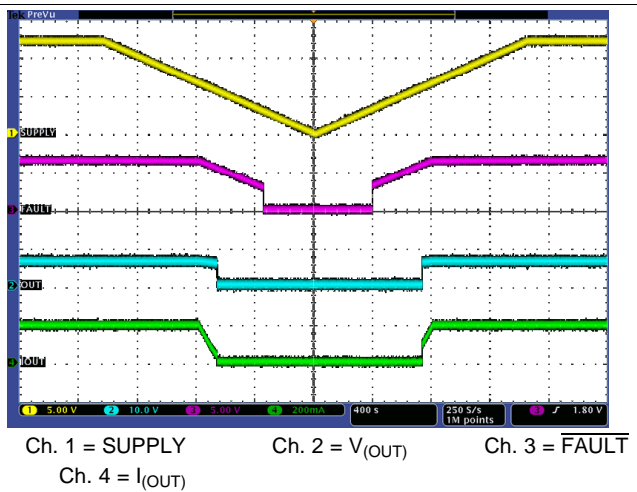

Figure 16. Slow Decrease and Slow Increase of Supply Voltage

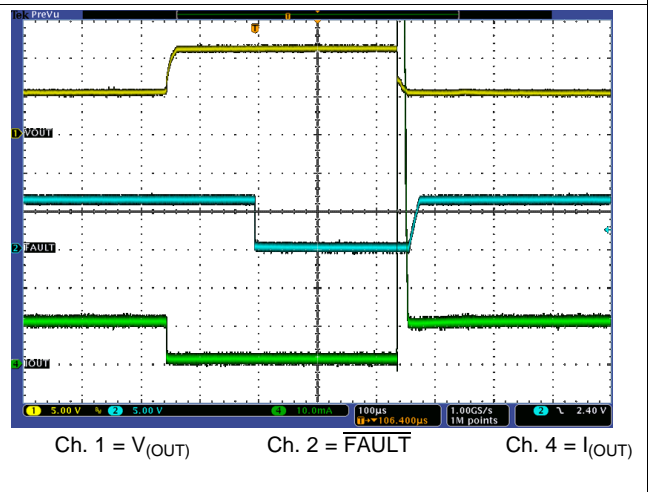

Figure 17. LED Open-Circuit Protection and Recovery

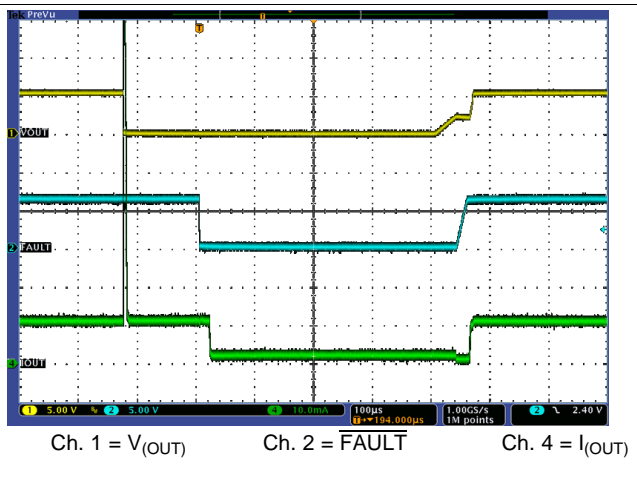

Figure 18. LED Short-Circuit Protection and Recovery

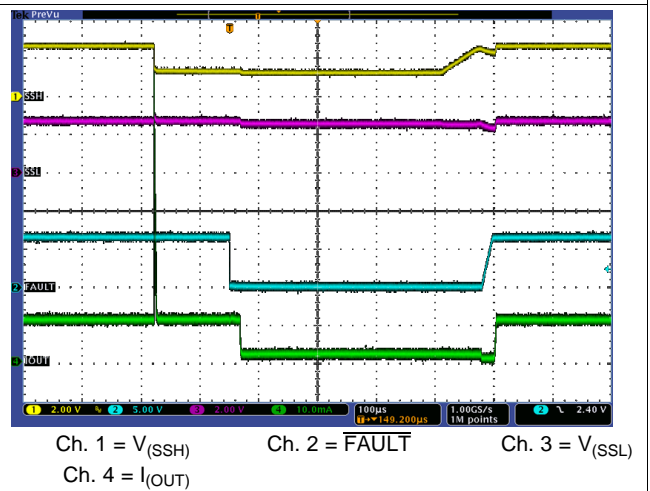

Figure 19. Single-LED-Short Protection and Recovery

## 7 Detailed Description

### 7.1 Overview

The TPS92610-Q1 device is one of a family of single-channel linear LED drivers. The family provides a simple solution for automotive LED applications. Different package options in the family provide a variety of current ranges and diagnostic options. The TPS92610-Q1 device in an HTSSOP-14 package supports LED open-circuit detection and short-to-ground detection. Unique single-LED-short detection in the TPS92610-Q1 device can help diagnose if one LED within a string is shorted. A one-fails–all-fail fault bus allows the TPS92610-Q1 device to be used together with the TPS9261x-Q1, TPS9263x-Q1, and TPS9283x-Q1 families.

The output current can be set by an external  $R_{(SNS)}$  resistor. Current flows from the supply through the  $R_{(SNS)}$  resistor into the internal current source and to the LEDs.

### 7.2 Functional Block Diagram

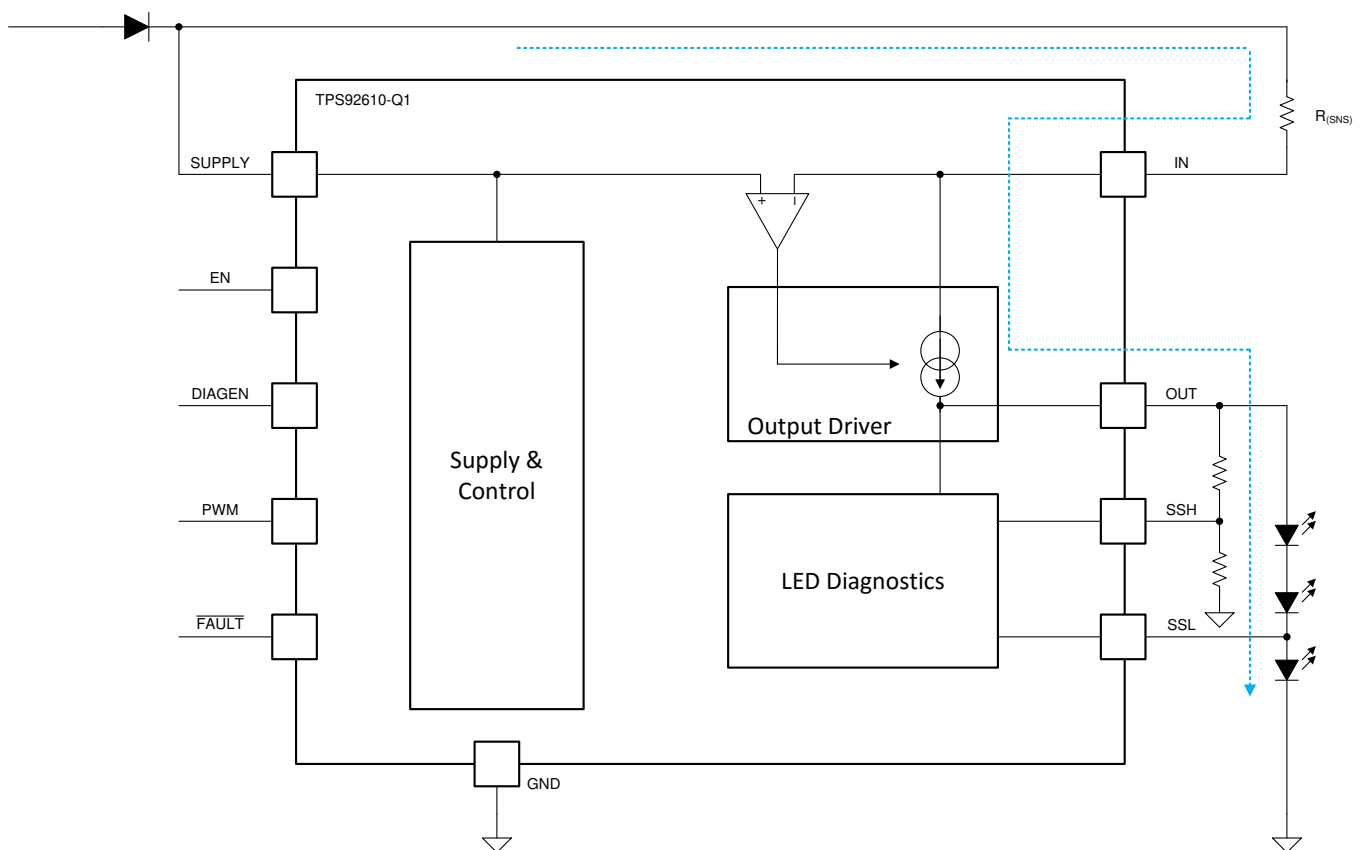

Copyright ©2017, Texas Instruments Incorporated

## 7.3 Feature Description

### 7.3.1 Device Bias

#### 7.3.1.1 Power-On Reset (POR)

The TPS92610-Q1 device has an internal power-on-reset (POR) function. When power is applied to SUPPLY, the internal POR holds the device in the reset state until  $V_{(SUPPLY)}$  is above  $V_{(POR\_rising)}$ .

#### 7.3.1.2 Low-Quiescent-Current Fault Mode

The TPS92610-Q1 device consumes minimal quiescent current when its  $\overline{FAULT}$  pin is externally pulled LOW. At the same time, the device shuts down the output driver.

## Feature Description (continued)

If device detects an internal fault, it pulls the  $\overline{\text{FAULT}}$  output LOW with constant current to signal a fault alarm on the one-fails–all-fail fault bus.

### 7.3.2 Constant-Current Driver

The TPS92610-Q1 device has a high-side constant-current integrated driver. The device senses channel current with an external high-side current-sense resistor,  $R_{(\text{SNS})}$ . A current regulation loop drives an internal transistor and regulates the current-sense voltage at the current-sense resistor to  $V_{(\text{CS\_REG})}$ . When the output driver is in regulation, the output current can be set using the following equation.

$$I_{(\text{OUT})} = \frac{V_{(\text{CS\_REG})}}{R_{(\text{SNS})}} \quad (1)$$

### 7.3.3 Device Enable

The TPS92610-Q1 device has an enable input, EN. When EN is low, the device is in sleep mode with ultralow quiescent current  $I_{(\text{Shutdown})}$ . This low current helps to save system-level current consumption in applications where battery voltage directly connects to the device without high-side switches.

### 7.3.4 PWM Dimming

The TPS92610-Q1 device supports PWM output dimming via PWM input dimming and supply dimming.

The PWM input functions as an enable for the output current. When the PWM input is low, the device also disables the diagnostic features.

Supply dimming applies PWM dimming on the power input. For an accurate PWM threshold, TI recommends using a resistor divider on the PWM input to set the PWM threshold higher than  $V_{(\text{POR\_rising})}$ .

### 7.3.5 Diagnostics

The TPS92610-Q1 device provides advanced diagnostics and fault protection features for automotive exterior lighting systems. The device is able to detect and protect from LED string short-to-GND, LED string open-circuit, and single-LED-short scenarios. It also supports a one-fails–all-fail fault bus that could flexibly fit different legislative requirements.

#### 7.3.5.1 DIAGEN

The TPS92610-Q1 device supports the DIAGEN pin with an accurate threshold to disable the open-circuit and single-LED-short diagnostic functions. With a resistor divider, the DIAGEN pin can be used to sense SUPPLY voltage with a resistor-programmable threshold. With the DIAGEN feature, the device is able to avoid false error reports due to low-dropout voltage and to drive maximum current in low-dropout mode when the input voltage is not high enough for current regulation.

When  $V_{(\text{DIAGEN})}$  is higher than the threshold  $V_{\text{IH}(\text{DIAGEN})}$ , the device enables LED open-circuit and single-LED-short diagnostics. When  $V_{(\text{DIAGEN})}$  is lower than the threshold  $V_{\text{IL}(\text{DIAGEN})}$ , the device disables LED-open-circuit and single-LED-short diagnostics.

#### 7.3.5.2 Low-Dropout Mode

When the supply voltage drops, the TPS92610-Q1 device tries to regulate current by driving internal transistors in the linear region, also known as low-dropout mode, because the voltage across the sense resistor fails to reach the regulation target.

In low-dropout mode, the open-circuit diagnostic must be disabled. Otherwise, the device treats the low-dropout mode as an open-circuit fault. The DIAGEN pin is used to avoid false diagnostics on the output channel due to low supply voltage.

When the DIAGEN voltage is low, single-LED short- and open-circuit detection is ignored. When the DIAGEN voltage is high, single-LED short- and open-circuit detection return to normal operation.

In dropout mode, a diode in parallel with the sense resistor is recommended to clamp the voltage between SUPPLY and IN (across the sense resistor) in case of a large current pulse during recovery.

## Feature Description (continued)

### 7.3.5.3 Open-Circuit Detection

The TPS92610-Q1 device has LED open-circuit detection. Open-circuit detection monitors the output voltage when the channel is in the ON state. Open-circuit detection is only enabled when DIAGEN is HIGH. A short-to-battery fault is also detected as an LED open-circuit fault.

The device monitors dropout-voltage differences between the IN and OUT pins when PWM is HIGH. The voltage difference  $V_{(IN)} - V_{(OUT)}$  is compared with the internal reference voltage  $V_{(OPEN\_th\_rising)}$  to detect an LED open-circuit failure. If  $V_{(IN)} - V_{(OUT)}$  falls below the  $V_{(OPEN\_th\_rising)}$  voltage longer than the deglitch time of  $t_{(OPEN\_deg)}$ , the device asserts an open-circuit fault. Once an LED open-circuit failure is detected, the constant-current source pulls the fault bus down. During the deglitch time period, if  $V_{(IN)} - V_{(OUT)}$  rises above  $V_{(OPEN\_th\_falling)}$ , the deglitch timer is reset.

When the device is in auto-retry, the device keeps the output ON to retry if the PWM input is HIGH; the device sources a small current  $I_{(retry)}$  from IN to OUT when PWM input is LOW. In either scenario, once a faulty channel recovers, the device resumes normal operation and releases the  $\overline{FAULT}$  pulldown.

### 7.3.5.4 Short-to-GND Detection

The TPS92610-Q1 device has LED short-to-GND detection. Short-to-GND detection monitors the output voltage when the channel is in the ON state. Once a short-to-GND LED failure is detected, the device turns off the output channel and retries automatically, ignoring the PWM input. If the retry mechanism detects removal of the LED short-to-GND fault, the device resumes normal operation.

The device monitors the  $V_{(OUT)}$  voltage and compares it with the internal reference voltage to detect a short-to-GND failure. If  $V_{(OUT)}$  falls below  $V_{(SG\_th\_rising)}$  longer than the deglitch time of  $t_{(SG\_deg)}$ , the device asserts the short-to-GND fault and pulls  $\overline{FAULT}$  low. During the deglitching time period, if  $V_{(OUT)}$  rises above  $V_{(SG\_th\_falling)}$ , the timer is reset.

Once the device has asserted a short-to-GND fault, the device turns OFF the output channel and retries automatically with a small current. When retrying, the device sources a small current  $I_{(retry)}$  from IN to OUT to pull up the LED loads continuously. Once auto-retry detects output voltage rising above  $V_{(SG\_th\_falling)}$ , it clears the short-to-GND fault and resumes normal operation.

### 7.3.5.5 Single-LED-Short Detection

The TPS92610-Q1 device supports single-LED-short detection by using the SSH and SSL pins. In case there is no need of this feature, SSH and SSL must be tied together to a resistor divider to avoid false alarms as shown in [Figure 21](#).

The TPS92610-Q1 device has integrated a precision comparator to monitor a single-LED-short failure. The comparator uses the bottom LED forward voltage  $V_{(SSL)}$  as a reference and monitors the string voltage  $V_{(OUT)}$  with resistor divider  $R_1$  and  $R_2$  at  $V_{(SSH)}$ .

If a single-LED short is detected, the device turns off the output channel and retries with a small current  $I_{(RETRY)}$ . Once the fault is removed, the device automatically resumes normal operation.

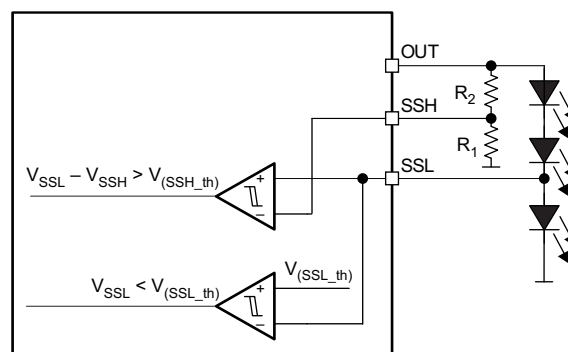

Copyright © 2017, Texas Instruments Incorporated

**Figure 20. Single-LED Short Detection**

## Feature Description (continued)

Use the following equation to calculate the ratio of R1 and R2.

$$R_2 = (\text{No. of LEDs} - 1) \times R_1 \quad (2)$$

By using the resistor divider with values calculated in 式 2, the voltages of SSH and SSL are then equal to the forward voltage of a single LED. With built-in comparators, the device can report failure if any of the LEDs is shorted within this string.

An internal resistor string on SSL and resistors R<sub>1</sub> and R<sub>2</sub> draw current from OUT. TI recommends total resistance of R<sub>1</sub> and R<sub>2</sub> greater than 100-kΩ, so the current has negligible effect on LED luminance.

Even within the same batch of LEDs, the LED forward voltage may vary from one to another. Taking account of forward voltage differences is necessary to avoid any false faults.

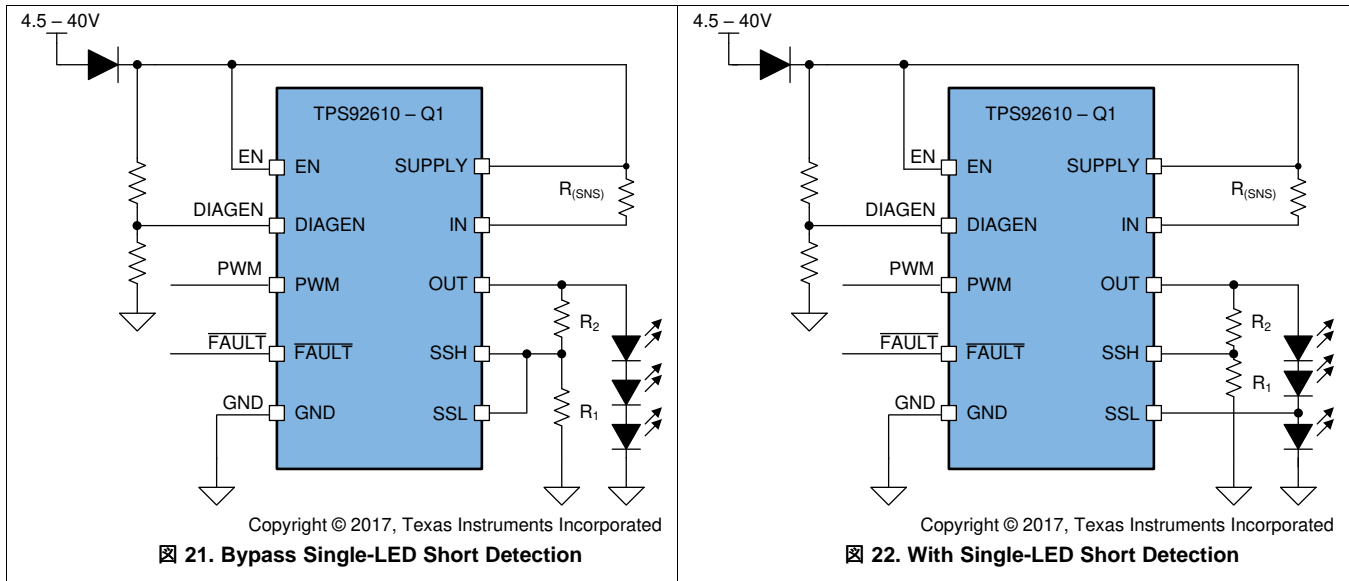

### 7.3.5.6 Overtemperature Protection

The TPS92610-Q1 device monitors device junction temperature. When the junction temperature reaches thermal shutdown threshold  $T_{(TSD)}$ , the output shuts down. Once the junction temperature falls below  $T_{(TSD)} - T_{(TSD\_HYS)}$ , the device resumes normal operation. During overtemperature protection, the FAULT bus is pulled low.

### 7.3.6 FAULT Bus Output With One-Fails–All-Fail

The TPS92610-Q1 device has a FAULT bus for diagnostics output. In normal operation,  $\overline{\text{FAULT}}$  is weakly pulled up by an internal pullup current source  $I_{(\text{FAULT\_pullup})}$  higher than  $V_{OH(\text{FAULT})}$ . If any fault scenario occurs, the FAULT bus is strongly pulled low by the internal pulldown current source  $I_{(\text{FAULT\_pulldown})}$ . Once  $V_{(\text{FAULT})}$  falls below  $V_{IL(\text{FAULT})}$ , all outputs shut down for protection. The faulty channel keeps retrying until the fault scenario is removed.

If  $\overline{\text{FAULT}}$  is externally pulled up with a current larger than  $I_{(\text{FAULT\_pulldown})}$ , the one-fails–all-fail function is disabled and only the faulty channel is turned off.

The FAULT bus is able to support up to 15 pieces of TPS9261x-Q1, TPS9263x-Q1, or TPS9283x-Q1 devices.

**Feature Description (continued)**

**表 1. Fault Table With DIAGEN = HIGH**

FAULT BUS STATUS	FAULT TYPE	DETECTION MECHANISM	CHANNEL STATE	DEGLITCH TIME	FAULT BUS	FAULT HANDLING ROUTINE	FAULT RECOVERY
FAULT floating or externally pulled up	Open-circuit or short-to-supply	$V_{(IN)} - V_{(OUT)} < V_{(OPEN\_th\_rising)}$	On	$t_{(OPEN\_deg)}$	Constant-current pulldown	Device works normally with FAULT pin pulled low. Device sources $I_{(retry)}$ current when PWM is LOW. Device keeps output normal when PWM is HIGH.	Auto recover
	Short-to-ground	$V_{(OUT)} < V_{(SG\_th\_rising)}$	On	$t_{(SG\_deg)}$	Constant-current pulldown	Device turns output off and retries with constant current $I_{(retry)}$ , ignoring the PWM input.	Auto recover
	Single-LED short	$V_{(SSL)} - V_{(SSH)} > V_{(SS\_th)}$ or $V_{(SSL)} < V_{(SSL\_th)}$	On	$t_{(SS\_deg)}$	Constant-current pulldown	Device turns output off and retry with constant current $I_{(retry)}$ , ignoring the PWM input.	Auto recover
	Overtemperature	$T_J > T_{(TSD)}$	On or off	$t_{(TSD\_deg)}$	Constant-current pulldown	Devices turns output off.	Auto recover
Externally pulled low	Device turns output off						

**表 2. Fault Table With DIAGEN = LOW**

FAULT BUS STATUS	FAULT TYPE	DETECTION MECHANISM	CHANNEL STATE	DEGLITCH TIME	FAULT BUS	FAULT HANDLING ROUTINE	FAULT RECOVERY
FAULT floating or externally pulled up	Open-circuit or short-to-supply	Ignored					
	Short-to-ground	$V_{OUT} < V_{(SG\_th\_rising)}$	On	$t_{(SG\_deg)}$	Constant-current pulldown	Device turns output off and retries with constant current $I_{(retry)}$ , ignoring the PWM input.	Auto recover
	Single-LED short	Ignored					
	Overtemperature	$T_J > T_{(TSD)}$	On or off	$t_{(TSD\_deg)}$	Constant-current pulldown	Device turns output off.	Auto recover
Externally pulled low	Device turns output off						

**7.4 Device Functional Modes**

**7.4.1 Undervoltage Lockout,  $V_{(SUPPLY)} < V_{(POR\_rising)}$**

When the device is in undervoltage lockout mode, the TPS92610-Q1 device disables all functions until the supply rises above the UVLO-rising threshold.

## Device Functional Modes (continued)

### 7.4.2 Normal Operation $V_{(\text{SUPPLY})} \geq 4.5 \text{ V}$

The device drives an LED string in normal operation. With enough voltage drop across SUPPLY and OUT, the device is able to drive the output in constant-current mode.

### 7.4.3 Low-Voltage Dropout

When the device drives an LED string in low-dropout mode, if the voltage drop is less than open-circuit detection threshold, the device may report a false open-circuit fault. Set the DIAGEN threshold higher than LED string voltage to avoid a false open-circuit detection.

### 7.4.4 Fault Mode

When the device detects an open circuit or a shorted LED, the device tries to pull down the  $\overline{\text{FAULT}}$  pin with a constant current. If the FAULT bus is pulled down, the device switches to fault mode and consumes a fault current of  $I_{(\text{FAULT})}$ .

## 8 Application and Implementation

### 注

Information in the following applications sections is not part of the TI component specification, and TI does not warrant its accuracy or completeness. TI's customers are responsible for determining suitability of components for their purposes. Customers should validate and test their design implementation to confirm system functionality.

### 8.1 Application Information

In automotive lighting applications, thermal performance and LED diagnostics are always design challenges for linear LED drivers.

The TPS92610-Q1 device is capable of detecting LED open-circuit, LED short-circuit and single-LED short failures. To increase current-driving capability, the TPS92610-Q1 device supports using an external a parallel resistor to help dissipate heat as shown in the following application, [Figure 25](#). This technique provides the low-cost solution of using external resistors to dissipate heat due to high input voltage, and still keeps high accuracy of the total current output. Note that the one-fails-all-fail feature is not supported by this topology.

### 8.2 Typical Application

#### 8.2.1 Single-Channel LED Driver With Full Diagnostics

The TPS92610-Q1 device is a potential choice for LED driver for applications with diagnostics requirements. In many cases, single-LED short diagnostics are mandatory for applications such as sequential turn indicators.

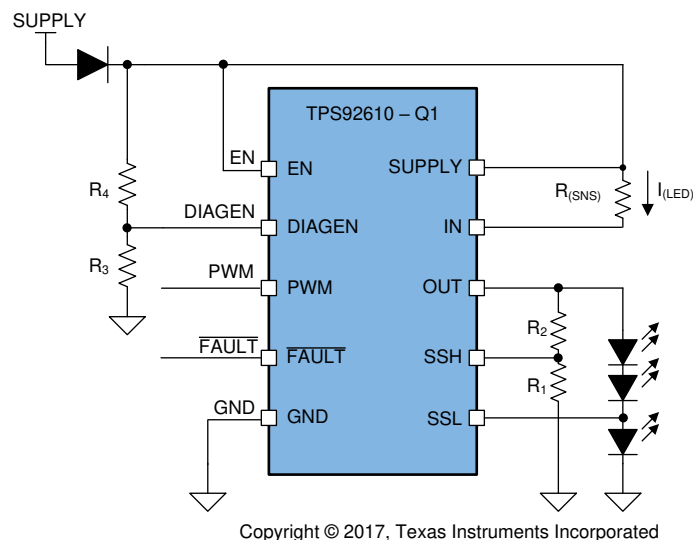

**Figure 23. Typical Application Diagram**

##### 8.2.1.1 Design Requirements

Input voltage ranges from 9 V to 16 V, LED maximum forward voltage  $V_{fmax} = 2.5$  V, minimum forward voltage  $V_{fmin} = 1.9$  V, current  $I_{(LED)} = 50$  mA.

##### 8.2.1.2 Detailed Design Procedure

Current setting by sense resistor is as described in [Equation 1](#).

$$R_{(SNS)} = \frac{R_{(CS\_REG)}}{I_{(LED)}} = 1.96 \Omega$$

(3)

LED-string maximum forward voltage =  $3 \times 2.5$  V = 7.5 V.



### Typical Application (continued)

With 400-mV headroom reserved for the TPS92610-Q1 device between SUPPLY and OUT, the TPS92610-Q1 device must disable open-circuit detection when the supply voltage is below 7.9 V by using the DIAGEN feature.

$$V_{IL(DIAG,min)} = \frac{7.9 \times R_3}{R_3 + R_4} \quad (4)$$

Set  $R_4 = 10 \text{ k}\Omega$ ,  $R_3 = 65.6 \text{ k}\Omega$ .

The single-LED short-detection resistor ratio can be calculated as follows.

$$\frac{R_2}{R_1} = 2 \quad (5)$$

If  $R_1 = 50 \text{ k}\Omega$ ,  $R_2 = 100 \text{ k}\Omega$

Total device power consumption at worst case is with 16-V input and LEDs at minimal forward voltage.

$$\begin{aligned} P_{(Max)} &= (V_{(SUPPLY)} - V_{(CS\_REG)} - V_{(OUT)}) \times I_{(LED)} + V_{(SUPPLY)} \times I_{(Quiescent)} \\ &= (16 - 3 \times 1.9 - 0.098) \times 0.05 + 16 \times 0.00025 = 0.5141 \text{ W} \end{aligned} \quad (6)$$

#### 8.2.1.3 Application Curve

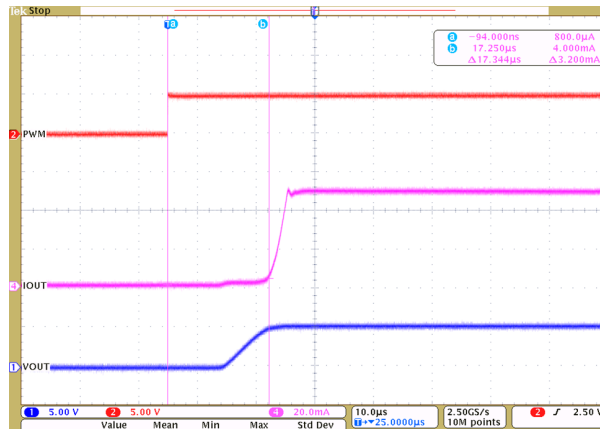

Ch. 1 =  $V_{(OUT)}$     Ch. 2 =  $V_{(PWM)}$     Ch. 4 =  $I_{(OUT)}$

图 24. Output Current With PWM Input

## Typical Application (continued)

### 8.2.2 Single-Channel LED Driver With Heat Sharing

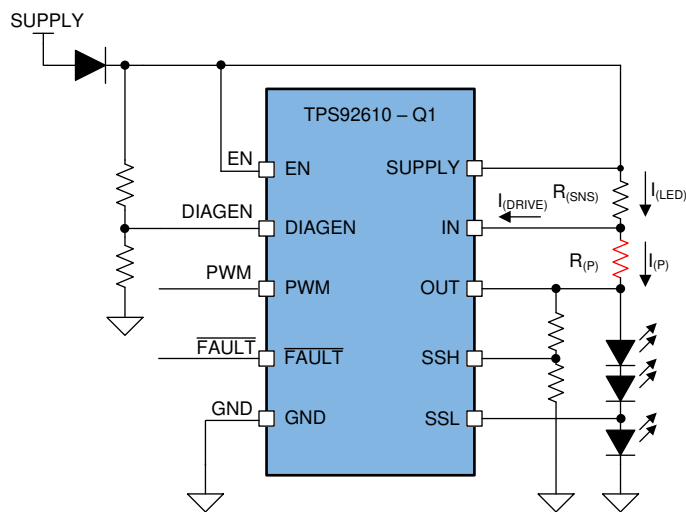

Copyright © 2017, Texas Instruments Incorporated

☒ 25. Heat Sharing With a Parallel Resistor

#### 8.2.2.1 Design Requirements

Input voltage range is 9 V to 16 V, LED maximum forward voltage  $V_{fmax} = 2.5$  V, minimum forward voltage  $V_{fmin} = 1.9$  V, current  $I_{(LED)} = 200$  mA.

#### 8.2.2.2 Detailed Design Procedure

Using parallel resistors, thermal performance can be improved by balancing current between the TPS92610-Q1 device and the external resistors as follows. As the current-sense resistor controls the total LED string current, the LED string current  $I_{(LED)}$  is set by  $V_{(CS\_REG)} / R_{(SNS)}$ , while the TPS92610-Q1 current  $I_{(DRIVE)}$  and parallel resistor current  $I_{(P)}$  combine to the total current.

Note that the parallel resistor path cannot be shut down by PWM or fault protection. If PWM or one-fails-all-fail feature is required, TI recommends an application circuit as described in [Single-Channel LED Driver With Full Diagnostics](#).

In linear LED driver applications, the input voltage variation contributes to most of the thermal concerns. The resistor current, as indicated by Ohm's law, depends on the voltage across the external resistors. The TPS92610-Q1 controls the driver current  $I_{(DRIVE)}$  to attain the desired total current. If  $I_{(P)}$  increases, the TPS92610-Q1 device decreases  $I_{(DRIVE)}$  to compensate, and vice versa.

While in low-dropout mode, the voltage across the  $R_{(P)}$  resistor may be close to zero, so that almost no current can flow through the external resistor  $R_{(P)}$ .

When the input voltage is high, the parallel-resistor current  $I_{(P)}$  is proportional to the voltage across the parallel resistor  $R_{(P)}$ . The parallel resistor  $R_{(P)}$  takes the majority of the total string current, generating maximum heat. The device must prevent current from draining out to ensure current regulation capability.

In this case, the parallel resistor value must be carefully calculated to ensure that 1) enough output current is achieved in low-dropout mode, 2) thermal dissipation for both the TPS92610-Q1 device and the resistor is within their thermal dissipation limits, and 3) device current in the high-voltage mode is above the minimal output-current requirement.

Current setting by sense resistor is as described in [式 7](#).

## Typical Application (continued)

$$R_{(SNS)} = \frac{V_{(CS\_REG)}}{I_{(LED)}} = 0.49\Omega$$

(7)

LED-string maximum forward voltage =  $3 \times 2.5 \text{ V} = 7.5 \text{ V}$ .

Parallel resistor  $R_{(P)}$  is recommended to consume 50% of the total current at maximum supply voltage.

$$R_{(P)} = \frac{V_{(SUPPLY)} - V_{(CS\_REG)} - V_{(OUT)}}{0.5 \times I_{(LED)}} = \frac{16 - 3 \times 1.9 - 0.098}{0.5 \times 0.2} \approx 100\Omega$$
(8)

Total device power consumption is maximum at 16 V input and LED minimal forward voltage.

$$\begin{aligned} P_{(DEV\_MAX)} &= (V_{(SUPPLY)} - V_{(CS\_REG)} - V_{(OUT)}) \times \left( I_{(LED)} - \frac{V_{(SUPPLY)} - V_{(CS\_REG)} - V_{(OUT)}}{R_{(P)}} \right) + V_{(SUPPLY)} \times I_{(Quiescent)} \\ &= (16 - 3 \times 1.9 - 0.098) \times 0.1 + 16 \times 0.00025 = 1.0242 \text{ W} \end{aligned}$$
(9)

Resistor  $R_{(P)}$  maximum power consumption is at 16-V input.

$$P_{(RP\_MAX)} = \frac{(V_{(SUPPLY)} - V_{(CS\_REG)} - V_{(OUT)})^2}{R_{(P)}} = \frac{(16 - 3 \times 1.9 - 0.098)^2}{100} = 1.04 \text{ W}$$
(10)

Users must consider the maximum power of both of the device and the parallel resistor.

Typical Application (continued)

8.2.2.3 Application Curve

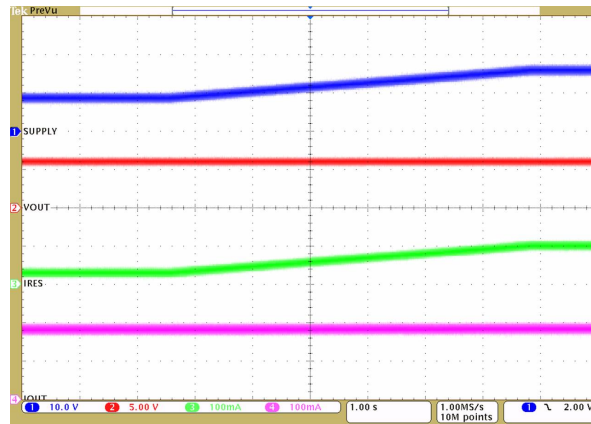

Ch. 1 =  $V_{(SUPPLY)}$       Ch. 2 =  $V_{(OUT)}$       Ch. 3 =  $I_{(P)}$

Ch. 4 =  $I_{(LED)}$        $V_{(SUPPLY)}$  increases from 9 V to 16 V

⊗ 26. Constant Output Current With Increasing Supply Voltage

## 9 Layout

### 9.1 Layout Guidelines

Thermal dissipation is the primary consideration for TPS92610-Q1 layout. TI recommends good thermal dissipation area connected to thermal pads with thermal vias.

### 9.2 Layout Example

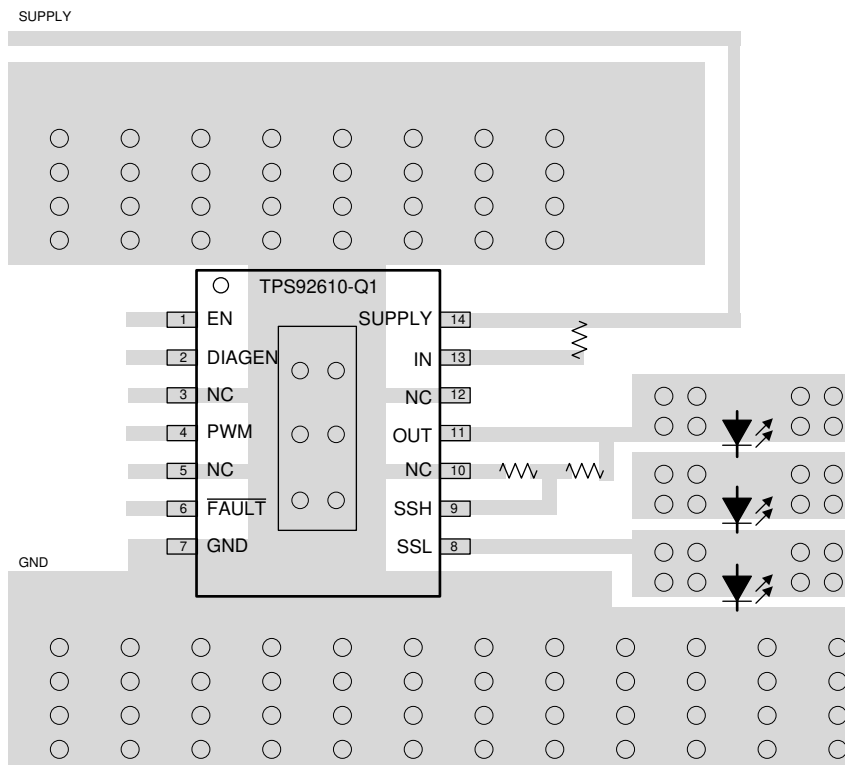

Copyright © 2017, Texas Instruments Incorporated

☒ 27. TPS92610-Q1 Example Layout Diagram

## 10 デバイスおよびドキュメントのサポート

### 10.1 ドキュメントのサポート

#### 10.1.1 関連資料

関連資料については、以下を参照してください。

- 『[TPS92610-Q1 EVMユーザー・ガイド](#)』
- 『[車外照明アプリケーションにおけるTPS92630-Q1の最大出力電流の計算方法](#)』
- 『[センター・ハイマウント・ストップ・ランプ\(CHMSL\)用の車載リニアLEDドライバのリファレンス・デザイン](#)』
- 『[ユーザー・ガイド: センター・ハイマウント・ストップ・ランプ\(CHMSL\)用の車載リニアLEDドライバのリファレンス・デザイン](#)』

#### 10.2 ドキュメントの更新通知を受け取る方法

ドキュメントの更新についての通知を受け取るには、[ti.com](http://ti.com)のデバイス製品フォルダを開いてください。右上の「アラートを受け取る」をクリックして登録すると、変更されたすべての製品情報に関するダイジェストを毎週受け取れます。変更の詳細については、修正されたドキュメントに含まれている改訂履歴をご覧ください。

#### 10.3 コミュニティ・リソース

[TI E2E™ support forums](#) are an engineer's go-to source for fast, verified answers and design help — straight from the experts. Search existing answers or ask your own question to get the quick design help you need.

Linked content is provided "AS IS" by the respective contributors. They do not constitute TI specifications and do not necessarily reflect TI's views; see TI's [Terms of Use](#).

#### 10.4 商標

PowerPAD, E2E are trademarks of Texas Instruments.  
All other trademarks are the property of their respective owners.

#### 10.5 静電気放電に関する注意事項



すべての集積回路は、適切なESD保護方法を用いて、取扱いと保存を行うようにして下さい。

静電気放電はわずかな性能の低下から完全なデバイスの故障に至るまで、様々な損傷を与えます。高精度の集積回路は、損傷に対して敏感であり、極めてわずかなパラメータの変化により、デバイスに規定された仕様に適合しなくなる場合があります。

#### 10.6 Glossary

[SLYZ022](#) — *TI Glossary*.

This glossary lists and explains terms, acronyms, and definitions.

## 11 メカニカル、パッケージ、および注文情報

以降のページには、メカニカル、パッケージ、および注文に関する情報が記載されています。これらの情報は、指定のデバイスに対して提供されている最新のデータです。このデータは予告なく変更されることがあり、ドキュメントが改訂される場合もあります。本データシートのブラウザ版を使用されている場合は、画面左側の説明をご覧ください。

**PACKAGING INFORMATION**

Orderable Device	Status (1)	Package Type	Package Drawing	Pins	Package Qty	Eco Plan (2)	Lead finish/ Ball material (6)	MSL Peak Temp (3)	Op Temp (°C)	Device Marking (4/5)	Samples
TPS92610QPWRQ1	ACTIVE	HTSSOP	PWP	14	2000	RoHS & Green	NIPDAU	Level-3-260C-168 HR	-40 to 125	TP92610	Samples

(1) The marketing status values are defined as follows:

**ACTIVE:** Product device recommended for new designs.

**LIFEBUY:** TI has announced that the device will be discontinued, and a lifetime-buy period is in effect.

**NRND:** Not recommended for new designs. Device is in production to support existing customers, but TI does not recommend using this part in a new design.

**PREVIEW:** Device has been announced but is not in production. Samples may or may not be available.

**OBSOLETE:** TI has discontinued the production of the device.

(2) **RoHS:** TI defines "RoHS" to mean semiconductor products that are compliant with the current EU RoHS requirements for all 10 RoHS substances, including the requirement that RoHS substance do not exceed 0.1% by weight in homogeneous materials. Where designed to be soldered at high temperatures, "RoHS" products are suitable for use in specified lead-free processes. TI may reference these types of products as "Pb-Free".

**RoHS Exempt:** TI defines "RoHS Exempt" to mean products that contain lead but are compliant with EU RoHS pursuant to a specific EU RoHS exemption.

**Green:** TI defines "Green" to mean the content of Chlorine (Cl) and Bromine (Br) based flame retardants meet JS709B low halogen requirements of <=1000ppm threshold. Antimony trioxide based flame retardants must also meet the <=1000ppm threshold requirement.

(3) MSL, Peak Temp. - The Moisture Sensitivity Level rating according to the JEDEC industry standard classifications, and peak solder temperature.

(4) There may be additional marking, which relates to the logo, the lot trace code information, or the environmental category on the device.

(5) Multiple Device Markings will be inside parentheses. Only one Device Marking contained in parentheses and separated by a "-" will appear on a device. If a line is indented then it is a continuation of the previous line and the two combined represent the entire Device Marking for that device.

(6) Lead finish/Ball material - Orderable Devices may have multiple material finish options. Finish options are separated by a vertical ruled line. Lead finish/Ball material values may wrap to two lines if the finish value exceeds the maximum column width.

**Important Information and Disclaimer:** The information provided on this page represents TI's knowledge and belief as of the date that it is provided. TI bases its knowledge and belief on information provided by third parties, and makes no representation or warranty as to the accuracy of such information. Efforts are underway to better integrate information from third parties. TI has taken and continues to take reasonable steps to provide representative and accurate information but may not have conducted destructive testing or chemical analysis on incoming materials and chemicals. TI and TI suppliers consider certain information to be proprietary, and thus CAS numbers and other limited information may not be available for release.

In no event shall TI's liability arising out of such information exceed the total purchase price of the TI part(s) at issue in this document sold by TI to Customer on an annual basis.



**TAPE AND REEL INFORMATION**

**QUADRANT ASSIGNMENTS FOR PIN 1 ORIENTATION IN TAPE**

\*All dimensions are nominal

Device	Package Type	Package Drawing	Pins	SPQ	Reel Diameter (mm)	Reel Width W1 (mm)	A0 (mm)	B0 (mm)	K0 (mm)	P1 (mm)	W (mm)	Pin1 Quadrant
TPS92610QPWRQ1	HTSSOP	PWP	14	2000	330.0	12.4	6.9	5.6	1.6	8.0	12.0	Q1

**TAPE AND REEL BOX DIMENSIONS**

\*All dimensions are nominal

Device	Package Type	Package Drawing	Pins	SPQ	Length (mm)	Width (mm)	Height (mm)
TPS92610QPWPRQ1	HTSSOP	PWP	14	2000	350.0	350.0	43.0

## GENERIC PACKAGE VIEW

**PWP 14**

**PowerPAD TSSOP - 1.2 mm max height**

4.4 x 5.0, 0.65 mm pitch

PLASTIC SMALL OUTLINE

This image is a representation of the package family, actual package may vary.  
Refer to the product data sheet for package details.

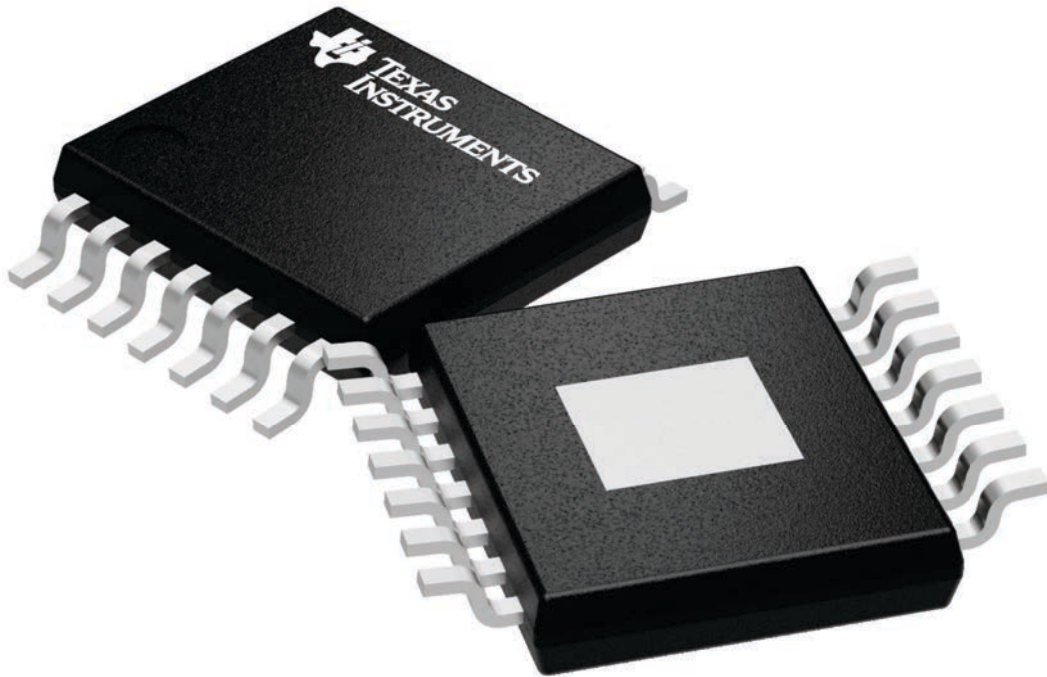

4224995/A

## 重要なお知らせと免責事項

TI は、技術データと信頼性データ (データシートを含みます)、設計リソース (リファレンス・デザインを含みます)、アプリケーションや設計に関する各種アドバイス、Web ツール、安全性情報、その他のリソースを、欠陥が存在する可能性のある「現状のまま」提供しており、商品性および特定目的に対する適合性の黙示保証、第三者の知的財産権の非侵害保証を含むいかなる保証も、明示的または黙示的にかかわらず拒否します。

これらのリソースは、TI 製品を使用する設計の経験を積んだ開発者への提供を意図したものです。(1) お客様のアプリケーションに適した TI 製品の選定、(2) お客様のアプリケーションの設計、検証、試験、(3) お客様のアプリケーションに該当する各種規格や、その他のあらゆる安全性、セキュリティ、規制、または他の要件への確実な適合に関する責任を、お客様のみが単独で負うものとします。

上記の各種リソースは、予告なく変更される可能性があります。これらのリソースは、リソースで説明されている TI 製品を使用するアプリケーションの開発の目的でのみ、TI はその使用をお客様に許諾します。これらのリソースに関して、他の目的で複製することや掲載することは禁止されています。TI や第三者の知的財産権のライセンスが付与されている訳ではありません。お客様は、これらのリソースを自身で使用した結果発生するあらゆる申し立て、損害、費用、損失、責任について、TI およびその代理人を完全に補償するものとし、TI は一切の責任を拒否します。

TI の製品は、[TI の販売条件](#)、または [ti.com](#) やかかる TI 製品の関連資料などのいずれかを通じて提供する適用可能な条項の下で提供されています。TI がこれらのリソースを提供することは、適用される TI の保証または他の保証の放棄の拡大や変更を意味するものではありません。

お客様がいかなる追加条項または代替条項を提案した場合でも、TI はそれらに異議を唱え、拒否します。

郵送先住所 : Texas Instruments, Post Office Box 655303, Dallas, Texas 75265  
Copyright © 2024, Texas Instruments Incorporated