

## TI Designs: TIDA-01214

# 16ビットADCおよびデジタル・アイソレータを使用した絶縁型、高精度、アナログ入力モジュールのリファレンス・デザイン



### 概要

このリファレンス・デザインは、保護および測定範囲(IEC 61850-9-2のサンプリング要件を含む)をカバーした広い入力範囲にわたって、高精度の16ビットSAR ADCを使用したAC電圧および電流入力の正確な測定を実現しながら、システム設計を簡素化して、トリップタイム性能および信頼性を高めるものです。アナログ入力モジュール(AIM)は、電源を内蔵したデジタル・アイソレータを使用して、ホスト・プロセスから絶縁されます。限定された機能と低コストの設計手法で、TI製品を3点だけ使用してAC AIMを設計し、システム・コストとボード・サイズを削減できます。アラーム機能により、サンプル・ベースでACアナログ入力フォルトを特定し、より高速なフォルト検出を実現します。ADCは追加補助チャンネルを備えており、デジタル・アイソレータの電源出力を診断できます。ゲイン・アンプを搭載した12ビットADS8668 ADCは、プログラム可能な内部範囲を使用してダイナミック・レンジを拡大できるため、システム・コストをさらに最適化できます。

### リソース

<a href="#">TIDA-01214</a>	デザイン・フォルダ
<a href="#">ADS8688</a>	プロダクト・フォルダ
<a href="#">ADS8668</a>	プロダクト・フォルダ
<a href="#">ISO7741</a>	プロダクト・フォルダ
<a href="#">ISOW7841</a>	プロダクト・フォルダ
<a href="#">OPA4180</a>	プロダクト・フォルダ
<a href="#">SN6505b</a>	プロダクト・フォルダ
<a href="#">TPS3836K33</a>	プロダクト・フォルダ
<a href="#">TPS22944</a>	プロダクト・フォルダ
<a href="#">TPS60241</a>	プロダクト・フォルダ
<a href="#">REG71055</a>	プロダクト・フォルダ
<a href="#">REF5040</a>	プロダクト・フォルダ
<a href="#">REF6041</a>	プロダクト・フォルダ
<a href="#">INA333</a>	プロダクト・フォルダ
<a href="#">OPA320</a>	プロダクト・フォルダ
<a href="#">OPA322</a>	プロダクト・フォルダ
<a href="#">TPS791</a>	プロダクト・フォルダ
<a href="#">TPS717</a>	プロダクト・フォルダ

<a href="#">TPS723</a>	プロダクト・フォルダ
<a href="#">SN74LVC1G17</a>	プロダクト・フォルダ
<a href="#">CSD17571Q2</a>	プロダクト・フォルダ

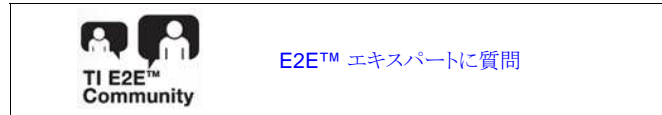

### 特長

- ADS8688A 16ビットADC (ADS8668またはADS8698) に基づき、デジタイズ・チェーン接続した2つのADCにより16のアナログ入力をサポート
- ホストから絶縁されたADCインターフェイスにより、ISOW7841を使用した厳しい動作条件で安全性が向上し、内蔵された電力コンバータにより60mAを上回る電流出力と45%以上の効率を実現
- AC AIMは14.9ビット超のENOB、91dB超のSNR、-110dBを上回るTHDを実現
- フロント・エンド・ゲイン・アンプを搭載した12ビットADC8668により、低コスト・アプリケーションにおける低電圧出力センサのダイナミック・レンジが拡大
- 診断機能: ISOW7841電源出力およびリップルの監視、電圧スーパーバイザ、LED (電力、アラーム、/CS)
- ISOW7841の入力で負荷スイッチを使用することにより、出力過負荷時にAC AIMを保護
- ステッチング・コンデンサ・ベースのボード・レイアウトを採用した4層基板により、放射エミッションを低減
- SDCCインターフェイスと性能評価用GUI

### アプリケーション

- マルチファンクションの保護リレー
- サブステーション・ベイ・コントローラ
- スタンドアロン・マーキング・ユニット(SAMU)
- RTU、FTU、DTU、またはFRTU
- ファクトリ・オートメーション用のPLC

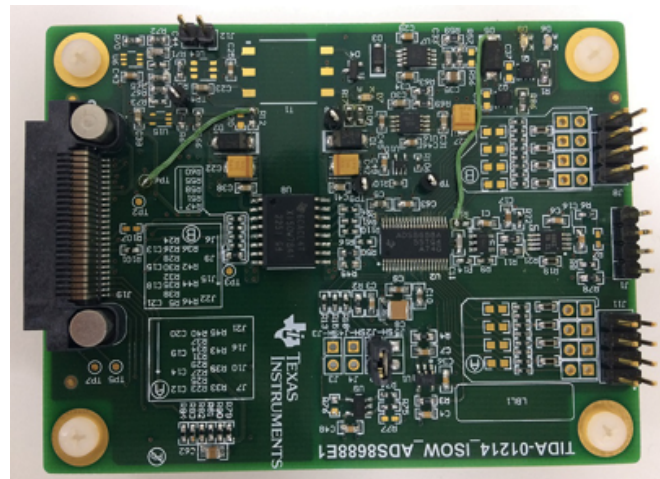
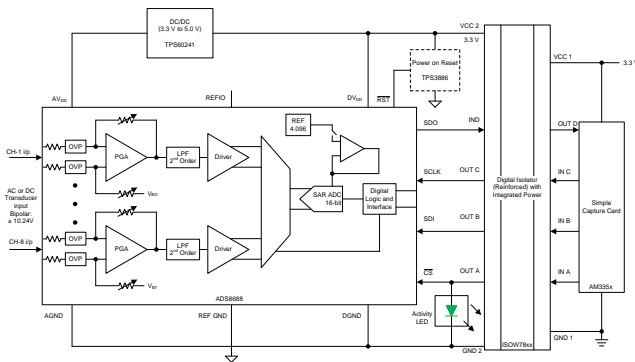

使用許可、知的財産、その他免責事項は、最終ページにあるIMPORTANT NOTICE (重要な注意事項)をご参照くださいますようお願いいたします。

## 1 System Description

Failure of power systems is one of the common problems faced by power generation, transmission, and distribution companies. Power outages result in loss of revenue and reduces generation capacity. Power utilities are working towards providing reliable power by using secondary protection, control, monitoring, and measurement systems to the power systems efficiency and reliability.

### 1.1 Introduction to Protection Relays

Digital protection relays detect defective lines, equipment, or other power system conditions that are abnormal or dangerous in nature. Digital protection relays detect and locate faults by measuring electrical quantities in the power system, which is different during normal and intolerable conditions. Measuring AC voltage and current inputs accurately over a wide input range is critical for the digital protection relays. The major functional components of a digital protection relay include data acquisition (analog filtering and sampling), measurement (phasor estimation), and logic (tripping, alarming, carrier send, and so on).

#### 1.1.1 Multifunction Protection Relay for Generation, Transmission, or Distribution Applications

The key inputs for the functioning of the protection relay are AC voltages and currents. Most of the protection algorithms are based on the amplitude, frequency, and the phase of the AC voltages and currents. The AC analog input module (AIM) is used to capture the output of the voltage and current transformers connected across the equipment being monitored. Depending on the monitored equipment and the protection function configured, the number of analog inputs can be 4, 8, 12, or 16.

#### 1.1.2 Merging Unit SAMU

The merging unit captures the voltage and current inputs from the equipment it connects to and provides the digital data to different IEDs using IEC 61850-9-2 protocol. Depending on the monitored equipment, the number of analog inputs can be 4, 8, 12, or 16.

### 1.1.3 Substation Bay Controller and Terminal Unit

The bay controller monitors analog and digital inputs from different primary equipments connected on the bay in a substation. The number of analog inputs depends on the bay controller configuration and can vary from 8 to 24.

## 1.2 Key System Specifications

表 1 shows the key system specifications for the isolated high-accuracy AIM reference design.

**表 1. Key System Specifications**

SERIAL NUMBER	PARAMETERS	DESCRIPTION	COMMENTS
1	ADC	12- or 16-bit SAR ADC with configurable input ranges	SPI
2	Number of channels	8 or 16 channels by daisy chaining multiple ADCs	Additional aux channels for diagnostics
3	Input range	$\pm 10.24$ V	With programmable input ranges
4	Sampling rate	500-kHz (max)	Meets IEC 61850-9-2 sampling requirements for protection and measurement
5	Input impedance	$> 1$ M $\Omega$	Same for all the input ranges
6	Digital isolation	Digital isolator with integrated power	Reinforced
7		Digital isolator with external power	Reinforced, provides flexibility in selection
8	Gain amplifier	Amplifier to scale low-voltage output from sensors	Gain depends on the sensor output range
	Reference	External reference with op amp buffer	Depends on performance requirement
9		External reference with integrated buffer	Depends on performance requirement
10	Host interface	SPI	Simplifies isolated communication interface
11	Diagnostics	Digital and analog power supply using auxiliary channels	Displayed on GUI
12		LED indication for alarm, power, and activity (chip select)	Visual indication
13	Power supply	Onboard DC-DC and LDO	With low ripple
14		Isolated power using transformer driver	Efficiency $> 70\%$
15		Onboard negative supply	Efficiency $> 80\%$

## 2 System Overview

This reference design provides a solution for accurate measurement of AC voltage and current inputs using a precision 16-bit successive approximation (SAR) analog-to-digital converter (ADC) over a wide input range covering protection and measurement range (including sampling requirements of IEC 61850-9-2), simplifying system design and improving trip time performance and reliability. The AIM is isolated from the host processor using a digital isolator with an integrated power converter. A complete AC AIM can be designed using only three TI products, optimizing system cost and size. The alarm feature identifies the AC analog input faults on a sample basis for faster fault detection. The ADC has an additional auxiliary channel that is used to diagnose the supply output of the digital isolator. A 12-bit ADS8668 ADC with a gain amplifier can be used to increase the dynamic range using programmable internal ranges, further optimizing the system cost.

### 2.1 Block Diagram

This reference design showcases the following configurations for improved system performance:

- ADS8688A-based, isolated, eight-channel input for measurement of AC or DC analog input MCU
- ADS8688-based, isolated, 16-channel input for measurement of AC or DC analog input by daisy chaining two eight-channel ADCs
- ADS8668-based, isolated, eight-channel input for measurement of AC inputs with a gain amplifier to scale the low-voltage output of the sensor

Choose the design architecture based on the accuracy requirements.

### 2.1.1 ADS8688-Based AC AIM

☒ 1 features the following functional blocks:

- ADC to sample eight channels of the AC analog input with a  $\pm 10.24\text{-V}$  input range
- Digital isolator with an integrated power for isolating the SPI from the ADC to the host along with generating isolated power
- DC-DC converter for generating 5 V for the ADC analog input
- Optional reference with buffer for providing an external reference to the ADC
- Alarm output buffer and MOSFET for indicating the alarm status
- Host interface for evaluating the performance of the ADC

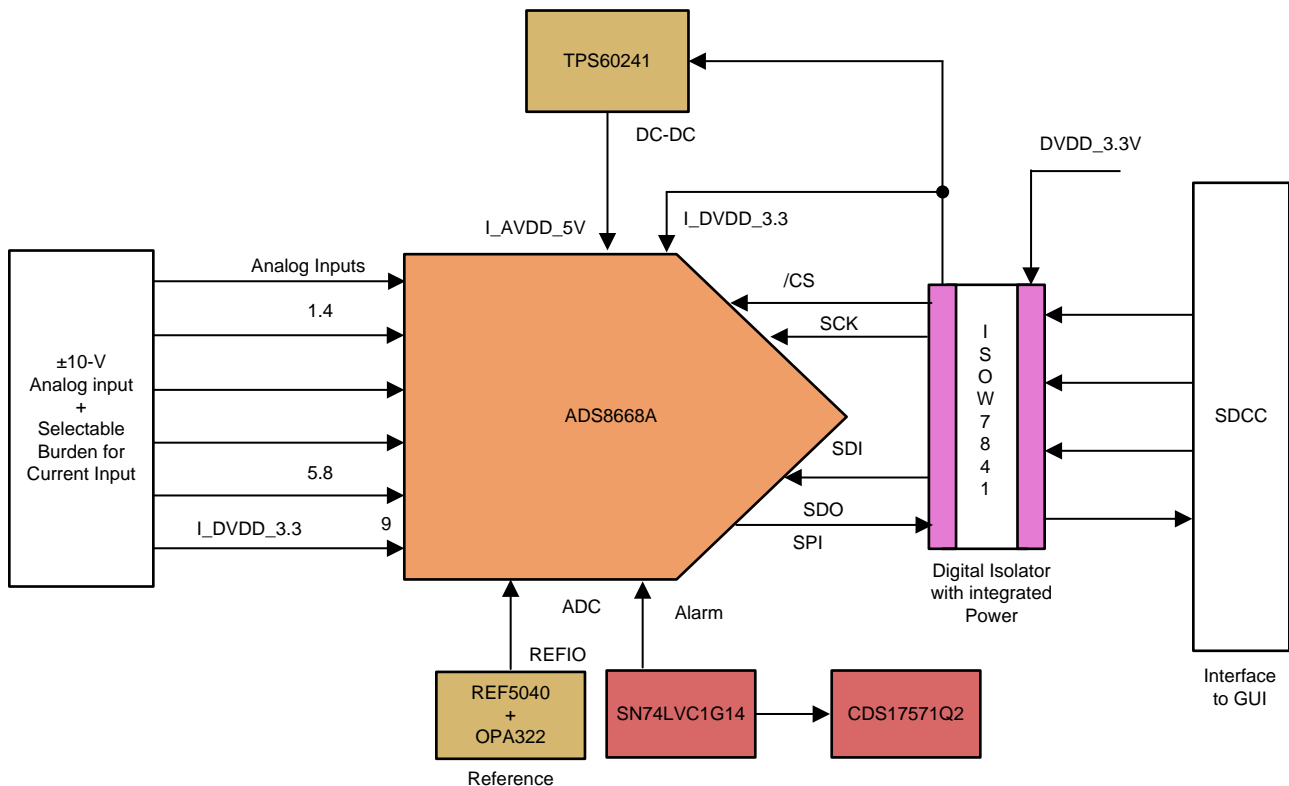

Copyright © 2017, Texas Instruments Incorporated

☒ 1. ADS8688 ADC-Based AC Analog Input

### 2.1.2 ADS8688-Based AC AIM With Daisy Chaining

Figure 2 features the following functional blocks:

- ADC for sampling 16 channels of AC analog input with a  $\pm 10.24$ -V input range by daisy chaining two ADCs
- Digital isolator with integrated power for isolating the SPI from the ADC to the host along with generating isolated power
- DC-DC converter for generating 5 V for ADC analog input
- Optional reference with an integrated buffer for providing an external reference to the ADC
- Alarm output buffer and MOSFET for indicating the alarm status
- Power on reset for resetting the ADC during power-up of the isolated power
- Host interface for evaluating the performance of the ADC

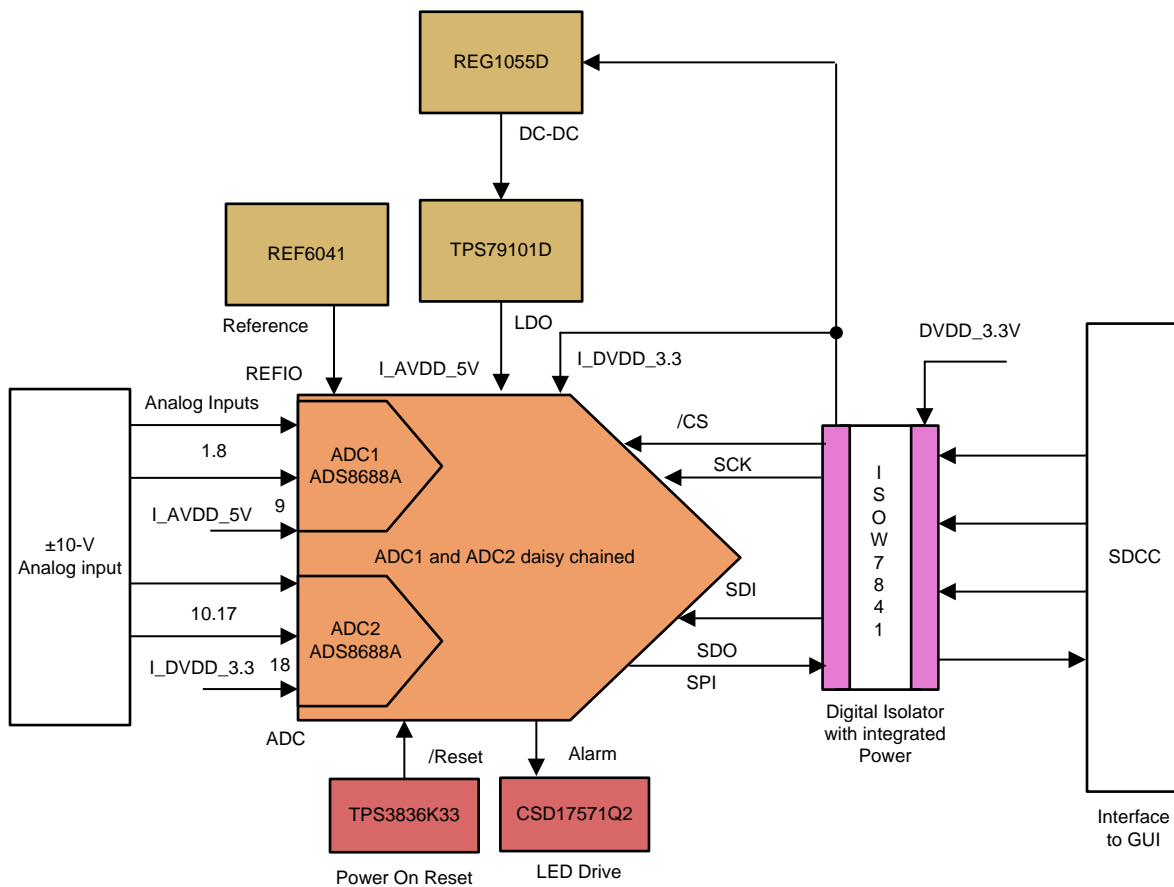

Copyright © 2017, Texas Instruments Incorporated

Figure 2. ADS8688-Based AC Analog Input With Daisy Chaining

### 2.1.3 ADS8668-Based AC AIM With Gain Amplifier

Figure 3 features the following functional blocks:

- ADC for sampling eight channels of AC analog input with a  $\pm 10.24\text{-V}$  input range
- Digital isolator with integrated power for isolating the SPI from the ADC to the host along with generating isolated power
- Gain amplifier for scaling the low-voltage sensor output to ADC range
- RTD input with current source for measurement of temperature
- DC-DC converter for generating 5.5 V used for generating  $\pm 5\text{ V}$  using an LDO and inverter
- Optional reference with buffer for providing external reference to the ADC
- Load switch for overload protection for protection of isolated output against overload protection
- Power on reset for resetting the ADC during power-up of the isolated power
- Host interface for evaluating the performance of the ADC

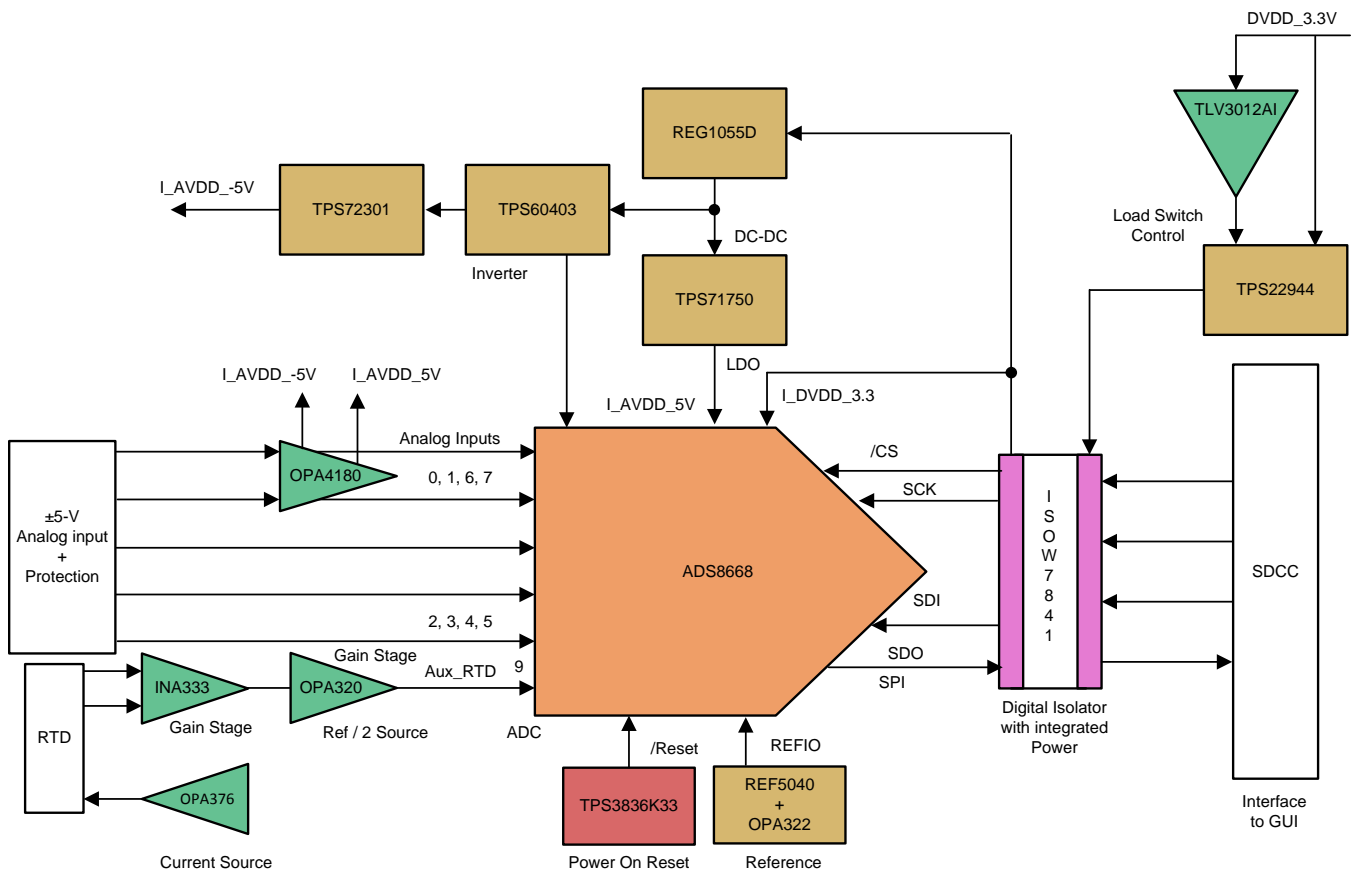

Copyright © 2017, Texas Instruments Incorporated

Figure 3. ADS8668-Based AC AIM

### 2.1.4 Precision ADC, External Reference, and Gain Amplifier

The key subsystem for the AC AIM is the ADC that is used to measure up to 16 inputs. A 16-bit ADC ADS8688 or ADS8688A with an alarm output or 12-bit ADC ADS8668 with a gain amplifier using the OPA4180 can be used to measure wide inputs using the internal programmable input ranges. The reference internal to the ADC has low drift that can be used for measurement. Alternatively, for improved performance, an external reference REF5040 with the buffer OPA322 can be used, or the REF6041 with internal buffer can be used.

### 2.1.5 Digital Isolator

The isolated interface for the AC AIM is designed using digital isolators. The ADCs have SPI with /CS, CLK, SDI, and SDO signals. A four-channel digital isolator ISOW7841 with reinforced isolation and integrated power can be used. For design flexibility, digital isolators with external isolated power can also be considered. The ISO7841 or ISO7741 can be used for providing the required isolation.

### 2.1.6 Power Supply

The output of the ISOW7841 is configured to provide 3.3 V. The output is used for ADC digital interface supply DVDD. The 3.3 V is stepped to the 5-V analog input using the low-ripple TPS60241 DC-DC converter or 5.5-V boost converter REG71055 and TPS71750 LDO.  $\pm 5$  V is applied to the gain amplifier used along with the ADS8668, and the required negative supply is generated using the TPS60403 and an LDO. A transformer driver SN6505 can be used to generate isolated power supply as an alternative to the power converter integrated with the digital isolator.

### 2.1.7 Diagnostics and Protection

Onboard diagnostics includes an LED using SN74LVC1G17 and MOSFET CSD17571 for indicating the ADC alarm output and ADC chip select for module activity. A load switch TPS22944 is used to protect the output of the ISOW7841 power converter against overload, and the TPS3836K33 is used to provide the reset during power-up and voltage monitoring to the ADC during power-up or during an overload condition.

## 2.2 Design Considerations

### 2.2.1 AC Current and Voltage Measurement Module

The data acquisition function in the protection relay is performed by the AC AIM and consists of the following subsystems.

#### 2.2.1.1 Current Sensor Input

Current measurement sensor that can be used include current transformers, shunts, Rogowski coils, Hall effect or Flux gate current sensors, optical current transformers, or low-power current transformers (LPCTs). In application using shunt for current sensing, the required isolation is provided by the isolation amplifier or isolated delta-sigma modulator.

#### 2.2.1.2 Voltage Sensor Input

Voltage measurement sensors that can be used include potential transformers, potential dividers, or capacitor voltage transformers. In application using potential divider for voltage measurement, the required isolation can be provided by the isolation amplifier or isolated delta-sigma modulator.



### 2.2.1.3 Signal Conditioning

A signal conditioning circuit is used to scale the voltage or current sensor output to the ADC range. A signal conditioning circuit depends on its application. The circuit can be a precision op amp amplifier, instrumentation amplifier, programmable gain amplifier, or a differential or isolation amplifier. The amplifier selection depends on the accuracy and temperature drift requirements.

### 2.2.1.4 Host Interface

The ADC is interfaced to a host that captures the digital values from the ADC and computes the electrical parameters used for protection, measurement, and control and monitoring applications.

### 2.2.1.5 ADC

Accurate measurements of voltage and current inputs are key performance requirements for grid infrastructure applications. Selecting an ADC is critical to the digital protection relay performance, and the measurement accuracy for protection, monitoring, and control depends on the ADC selection. Key performance parameters for ADC selection include ADC architecture, ADC resolution, ADC input sampling method, ADC input type and range, ADC power supply, clock, and reference. Scaling the sampling rate to meet IEC 61850-9-2 standards for both protection and measurement is another important ADC requirement.

## 2.2.2 Need for Isolation, Challenges, and Solutions

Power system equipment that fail are responsible for a large proportion of power system outages and associated interruption of electricity supply to customers. Other causes of interruption include extreme weather conditions, among others. If failures can be predicted before they occur, action can be taken to reduce the occurrence of unplanned outages of equipment, thus contributing to meeting performance targets and reducing the cost of interruptions. The inputs are isolated using an isolation amplifier, isolated delta-sigma modulators, current or potential transformers. Some of the common requirements for isolation of AC AIM include isolation type (basic or reinforced), jitter in pS, power supply integrated with an isolator or external, and the number of channels for I<sup>2</sup>C, SPI, or UART interface.

## 2.2.3 Reference Design Advantage

Using the ADS8688 with a daisy chain or the ADS8668 with a gain amplifier provides the following advantages during the design of the AC AIM:

- Uses only three TI products to design a wide input, eight-channel AC AIM
- Uses 12-bit ADS8668 ADC with a gain amplifier to increase the measurement dynamic range for sensors with a low-voltage output, reducing the system cost while providing a 15-bit performance by using the internal programmable input ranges
- $\pm 5$ -V power supply generated for the gain amplifier
- Programmable input ranges for scaling the input range based on the sensor outputs
- Performance can be scaled to > 19 bits by using the programmable internal ranges
- Bidirectional Inputs up to  $\pm 10.24$  V can be measured using a single 5-V analog input
- Provides options for power supply diagnostics (analog and digital supply) and alarm indication
- Uses reinforced digital isolator to isolate SPI to the host
- Isolated power supply generated using the ISOW7841 digital isolator with an integrated power

converter or using the SN6505B transformer driver

- Interfaces to the host using a simple SPI in standalone or daisy chained mode

## 2.3 Highlighted Products—System Design

### 2.3.1 Precision ADC, Reference, and Gain Amplifier

The ADC used and the configuration is shown in [Figure 4](#).

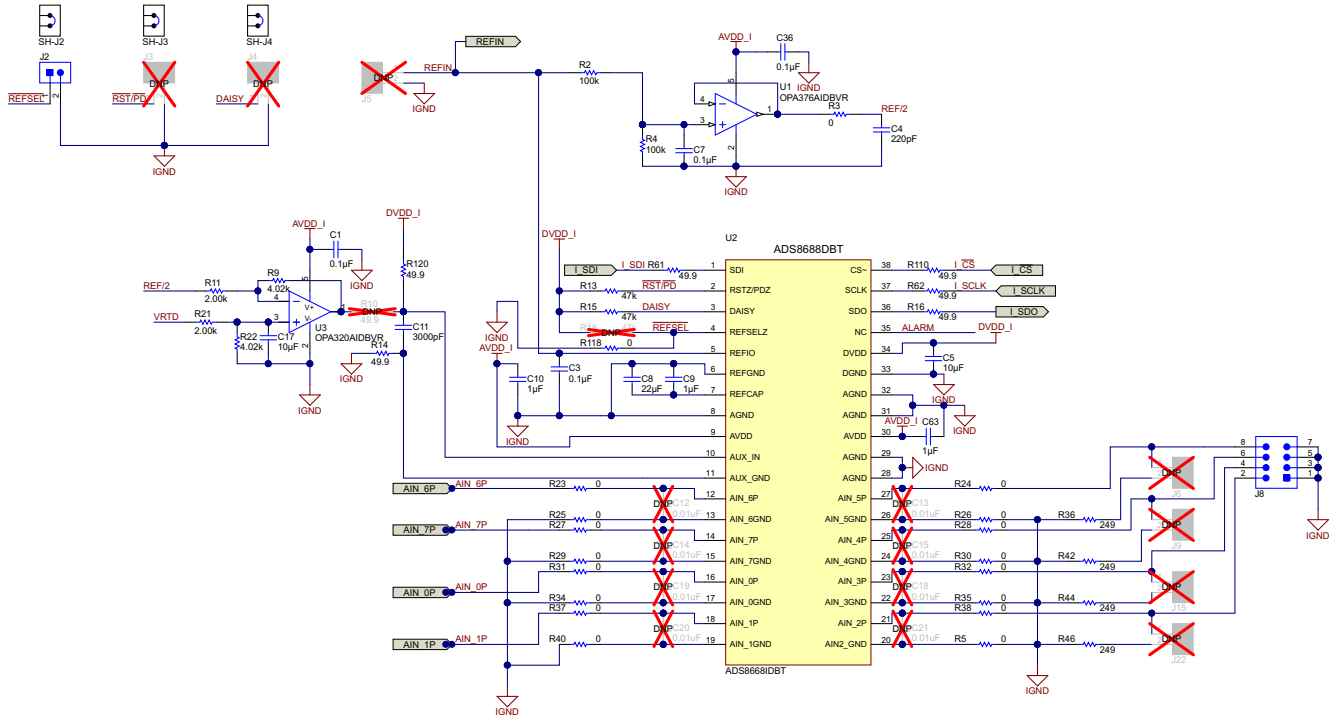

Copyright © 2017, Texas Instruments Incorporated

**Figure 4. ADS8688 Interface Schematic**

#### 2.3.1.1 16-Bit ADC ADS8688

The ADS8688 is an eight-channel, integrated data acquisition system based on a 16-bit SAR ADC, operating at a throughput of 500 kSPS. The devices feature integrated analog front-end circuitry for each input channel with overvoltage protection up to  $\pm 20$  V, an eight-channel multiplexer with automatic and manual scanning modes, and an on-chip, 4.096-V reference with low temperature drift. Operating on a single 5-V analog supply, each input channel on the devices can support true bipolar input ranges of  $\pm 10.24$  V,  $\pm 5.12$  V, and  $\pm 2.56$  V. The input range selection is software-programmable and independent for each channel. The devices offer a 1-M $\Omega$  constant resistive input impedance irrespective of the selected input range. The ADS8688 offers a simple SPI-compatible serial interface to the digital host and also support daisy-chaining of multiple devices. The digital supply operates from 1.65 to 5.25 V, enabling direct interface to a wide range of host controllers.

See the [ADS8688 product page](#) for more details.

#### 2.3.1.2 16-Bit ADC ADS8688A With Alarm Output

The ADS8688A is a eight-channel, integrated data acquisition system based on a 16-bit SAR ADC, operating at a throughput of 500 kSPS. Operating on a single 5-V analog supply, each input channel on the devices can support true bipolar input ranges of  $\pm 10.24$  V,  $\pm 5.12$  V,  $\pm 2.56$  V,  $\pm 1.28$  V, and  $\pm 0.64$  V.

See the [ADS8688A product page](#) for more details.

### 2.3.1.3 14-Bit ADS8678 or 12-Bit ADS8668 ADC

Depending on the application requirement 14-Bit ADC ADS8678 or 12-Bit ADC ADS8668 can be used. This design showcases 12-bit ADC with gain amplifiers. The ADS8668 is an eight-channel, integrated data acquisition system based on a 12-bit SAR ADC, operating at a throughput of 500 kSPS. The device features integrated analog front-end circuitry for each input channel with over voltage protection up to  $\pm 20$  V, eight-channel multiplexer with automatic and manual scanning modes, and an on-chip, 4.096-V reference with low temperature drift. Operating on a single 5-V analog supply, each input channel on the devices can support true bipolar input ranges of  $\pm 10.24$  V,  $\pm 5.12$  V,  $\pm 2.56$  V,  $\pm 1.28$  V, and  $\pm 0.64$  V.

See the [ADS8668 product page](#) for more details.

### 2.3.1.4 Quad-Precision Op Amp OPA4180

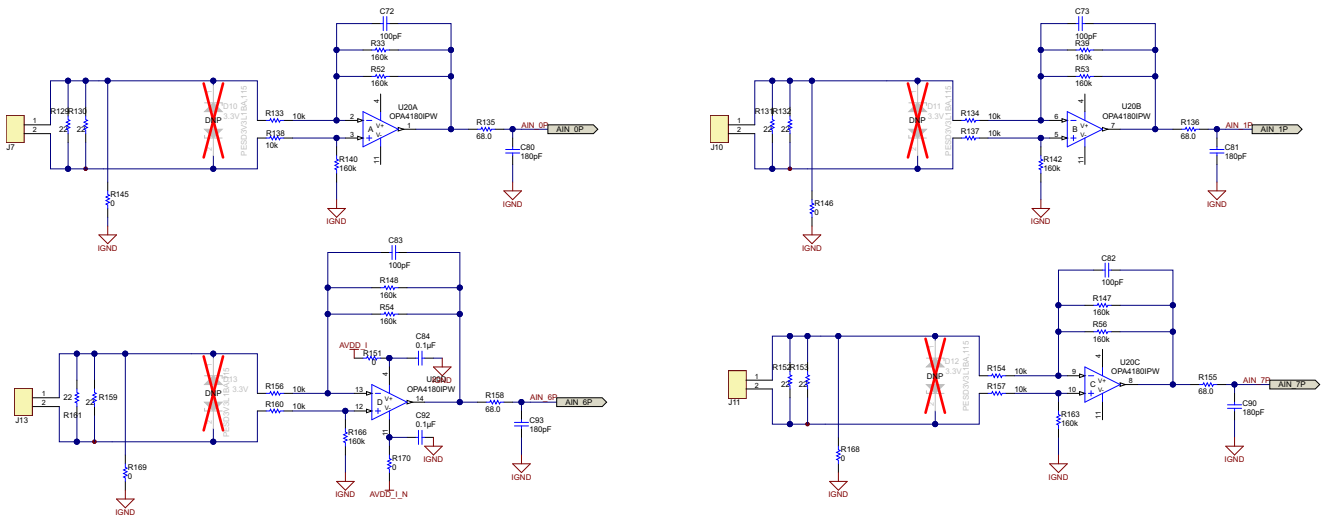

Copyright © 2017, Texas Instruments Incorporated

図 5. Precision Gain Amplifier Schematic

The OPA4180 operational amplifier uses zero-drift techniques to simultaneously provide low offset voltage (75  $\mu$ V) and near zero-drift over time and temperature. These miniature, high-precision, low quiescent current amplifiers offer high input impedance and rail-to-rail output swing within 18 mV of the rails. The input common-mode range includes the negative rail. Either single or dual supplies can be used in the range of 4 to 36 V ( $\pm 2$  to  $\pm 18$  V).

See the [OPA4180 product page](#) for more details.

### 2.3.1.5 Low-Noise, Low-Drift, High-Precision Reference REF5040

The REF5040 is a low-noise, low-drift, very high precision voltage reference. This reference is capable of both sinking and sourcing current and has excellent line and load regulation. Excellent temperature drift (3 ppm/ $^{\circ}$ C) and high accuracy (0.05%) are achieved using proprietary design techniques. These features, combined with very low noise, make the REF5040 ideal for use in high-precision data acquisition systems.

See the [REF5040 product page](#) for more details.

### 2.3.1.6 High-Precision Voltage Reference With Integrated High-Bandwidth Buffer REF6041

The REF6041 voltage reference has an integrated, low-output impedance buffer that enables the user to directly drive the REF pin of precision data converters while preserving linearity, distortion, and noise performance. Most precision SAR and Delta-Sigma ADCs, switch binary-weighted capacitors onto the REF pin during the conversion process. To support this dynamic load the output of the voltage reference must be buffered with a low-output impedance (high-bandwidth) buffer. The REF6000 family devices are well suited, but not limited, to drive the REF pin of the ADS88xx family of SAR ADCs and ADS127xx family of delta-sigma ADCs.

See the [REF6041 product page](#) for more details.

### 2.3.2 Interface Isolation Using Digital Isolator

This section provides information on different digital isolator options that can be considered for the design of the AC AIM.



図 6. ISOW7841 Configuration for ADC Interface

#### 2.3.2.1 Digital Isolator With Integrated Power ISOW7841

The ISOW7841 is a high-performance, quad-channel reinforced digital isolator with an integrated high-efficiency power converter. The integrated DC-DC converter provides up to 650 mW of isolated power at high efficiency and can be configured for various input and output voltage configurations. Therefore, these devices eliminate the need for a separate isolated power supply in space-constrained isolated designs.

See the [ISOW7841 product page](#) for more details.

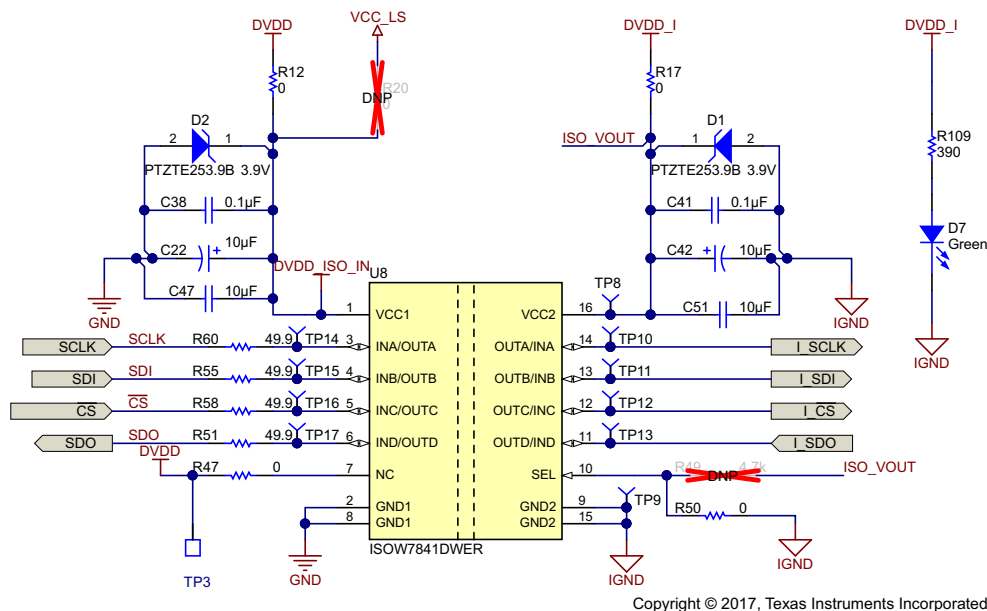
### 2.3.3 Power Supply

Alternative approach to isolate the binary input module (BIM) from the host is to use digital isolator and isolated power generated using transformer driver.

### 2.3.3.1 5-V AVDD and –5-V Supply for Gain Amplifier

The following subsections provide details for generating a  $\pm 5$ -V power supply for gain amplifiers. The output must be 5.12 V or above to use complete ADC range.

#### 2.3.3.1.1 REG71055

The REG71055D is a switched capacitor voltage converter that generates regulated, low-ripple output voltage from an unregulated input voltage. A wide input supply voltage from 1.8 to 5.5 V can be applied. The input voltage may vary above and below the output voltage and the output remains in regulation. The device works as step-up or step-down converters without the need of an inductor, providing low EMI DC-DC conversion.

See the [REG71055 product page](#) for more details.

#### 2.3.3.1.2 TPS60241

The TPS60241 device is a switched capacitor voltage converter, ideally suited for voltage-controlled oscillator (VCO) and phase-locked loop (PLL) applications that require low noise and tight tolerances. Its dual-cap design uses four ceramic capacitors to provide ultra-low output ripple with high efficiency while eliminating the need for inefficient linear regulators. The TPS60241 works with a 2.7- to 5.5-V input voltage providing a 5-V output. The devices work equally well for low EMI DC-DC step-up conversion without the need for an inductor.

See the [TPS60241 product page](#) for more details.

#### 2.3.3.1.3 TPS60403

The TPS60403 device generates an unregulated negative output voltage from an input voltage ranging from 1.6 to 5.5 V. The device is typically supplied by a pre-regulated supply rail of 5 V or 3.3 V. Only three external 1- $\mu$ F capacitors are required to build a complete DC-DC charge pump inverter. The TPS60403 can deliver a maximum output current of 60 mA with a typical conversion efficiency of greater than 90% over a wide output current range.

See the [TPS60403 product page](#) for more details.

#### 2.3.3.1.4 Isolated Power Supply Using Transformer Driver SN6505B or SN6501

The SN6505B is a low-noise, low-EMI push-pull transformer driver, specifically designed for small form factor, isolated power supplies. It drives low-profile, center-tapped transformers from a 2.25- to 5-V DC power supply. The SN6505B includes a soft-start feature that prevents high inrush current during power-up with large load capacitors.

See the [SN6505B product page](#) for more details.

### 2.3.4 Diagnostics and Protection

The following subsections describe the diagnostics and protection features.

### 2.3.4.1 Load Switch TPS22944

The TPS22944 load switch provides protection to systems and loads in high-current conditions. The device contains a 0.4- $\Omega$  current-limited P-channel MOSFET that can operate over an input voltage range of 1.62 to 5.5 V. Current is prevented from flowing when the MOSFET is off. The switch is controlled by an on/off input (ON), which is capable of interfacing directly with low-voltage control signals. The TPS22944 includes thermal shutdown protection that prevents damage to the device when a continuous overcurrent condition causes excessive heating by turning off the switch.

See the [TPS22944 product page](#) for more details. See [表 2](#) for details on the selection of load switches based on the power requirements.

**表 2. Load Switch Selection Options**

SERIAL NUMBER	PART NUMBER	DESCRIPTION
1	LM34902	300-mA Current Limited Power Switch
2	TPS2010	0.4-A, 2.7 to 5.5-V, Single High-Side MOSFET Switch IC, No Fault Reporting, Active-Low Enable
3	TPS22946	5.5-V, 0.2-A, 400-m $\Omega$ Selectable Current Limit Load Switch

### 2.3.4.2 Power-on Reset TPS3836K33

The TPS3836 family of supervisory circuits provides circuit initialization and timing supervision, primarily for DSP and processor-based systems. During power-on, RESET is asserted when the supply voltage VDD becomes higher than 1.1 V. Then, the supervisory circuit monitors VDD and keeps the RESET output active as long as VDD remains below the threshold voltage of VIT. An internal timer delays the return of the output to the inactive state (high) to ensure proper system reset. The delay time starts after VDD has risen above the threshold voltage VIT.

See the [TPS3836K33 product page](#) for more details.

### 2.3.5 Daisy Chaining of Multiple ADCs

This analog input module reference design showcases an AC AIM that samples up to 16 channels by daisy chaining two ADCs. Daisy chaining multiple ADCs simplifies the overall system design, provides a simple option to increase number of input channels, and provides simultaneous sampling capability between channels of each ADC.

### 2.3.6 Increasing Input Dynamic Range of ADS8668 Using External Precision Gain Amplifier

This reference design showcases an AC analog input module to sample up to eight channels with a wide dynamic range up to 15 bits. This design using a gain amplifier, which reduces the overall system cost and provides the required gain for sensors with low-voltage output.

### 2.3.7 Board Layout With ISOW7841

The ISOW7841 integrated signal and power isolation device simplifies system design and reduces board area. The use of low-inductance micro-transformers in the ISOW7841 device necessitates the use of high-frequency switching, resulting in higher radiated emissions compared to discrete solutions. The ISOW7841 device uses on-chip circuit techniques to reduce emissions compared to competing solutions. Techniques such as lower supply operation, the use of interlayer stitching capacitance, filters, and common-mode chokes can further reduce radiated emissions at the system level. See the application report [Low-Emission Designs with ISOW7841 Integrated Signal and Power Isolator](#) for more details.

### 2.3.8 Design Enhancements

The following subsections provide some of the design enhancement options.

#### 2.3.8.1 ISOW7841 Advantages

Two different approaches can provide isolated power and data interface using TI's digital isolator family.

##### 2.3.8.1.1 Isolated Interface With Transformer Driver and Digital Isolator

This approach consists of the following blocks that require multiple products as shown in [表 3](#):

- Digital isolator
- Transformer driver
- Isolation transformer
- LDO



The advantage of this approach is that the module can be a design using any of the digital isolators highlighted in 表 3 or with any of the digital isolator families, including devices with reinforced digital isolation or basic digital isolation.

表 3. Digital Isolator Families With External Isolated Power

SERIAL NUMBER	PART NUMBER	DESCRIPTION	INTERFACE TYPE
1	ISO7721	High-Speed, 5000-V <sub>RMS</sub> Dual-Channel Digital Isolators	UART
2	ISO7740	High-Speed, Low-Power, Robust EMC Quad-Channel Digital Isolator	GPIO
3	ISO7841	High-Immunity, 5.7-kV <sub>RMS</sub> Reinforced Quad-Channel 3/1 Digital Isolator, 100Mbps	SPI
4	ISO7840	High-Immunity, 5.7-kV <sub>RMS</sub> Reinforced Quad-Channel 4/0 Digital Isolator, 100 Mbps	GPIO
5	ISO7821	High-Immunity, 5.7-kV <sub>RMS</sub> Reinforced Dual-Channel 1/1 Digital Isolator, 100 Mbps	UART
6	ISO7641	6-kVpk Low-Power Quad Channels, 150-Mbps Digital Isolators	SPI

2.3.8.1.2 Isolated Interface Using ISOW7841

All of these components are integrated into one device, simplifying the design as shown in 図 7, reducing the solution size, and optimizing the cost. In applications where the required interface matches with the ISOW784x family, this solution is recommended.

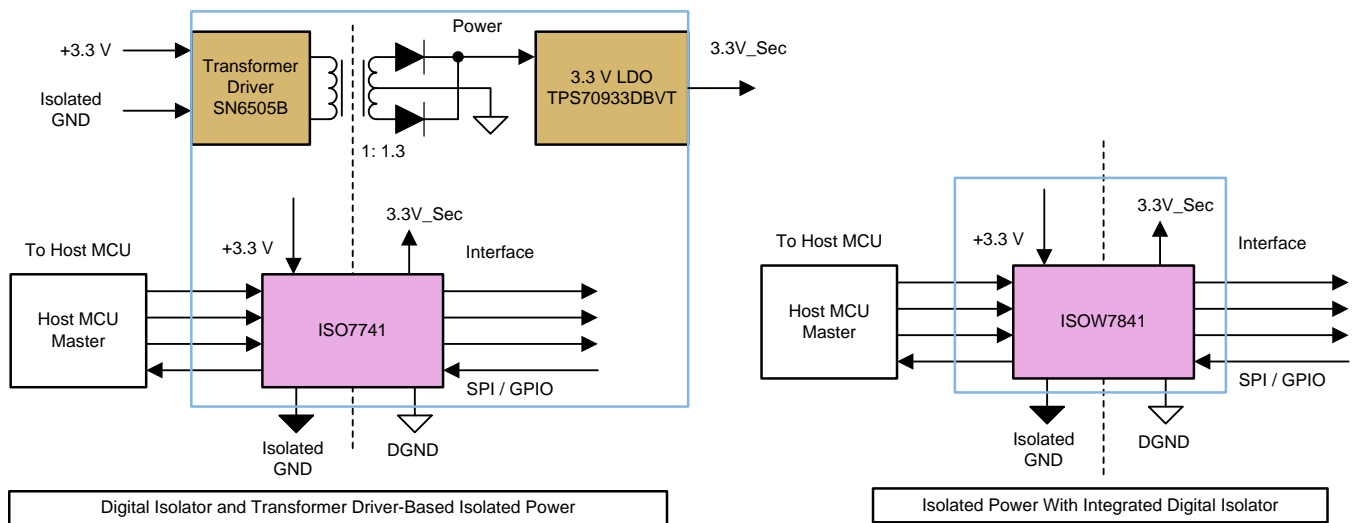

Copyright © 2017, Texas Instruments Incorporated

図 7. ISOW7841 Integrated Data and Power

The ISOW7841 with an integrated power converter provides the following advantages:

- Simplifies system design with increased reliability
- Provides current output > 65 mA with 46% efficiency
- Provides current limit and thermal overload protection
- Has a lower temperature rise and overall heat dissipation

### 2.3.9 Using LM27762 Dual-Output LDO With Integrated Charge Pump

An alternative approach to generating  $\pm 5$  V is to use the LM27762 Low-Noise Positive and Negative Output Integrated Charge Pump Plus LDO. This LDO simplifies the overall system design, and the output can be configured based on the application.

### 2.3.10 Achieving Higher Output Efficiency With Transformer Driver SN6505B

The digital isolator with integrated power provides a peak efficiency of  $\approx 48\%$ . In applications requiring greater efficiencies with no space constraint, the SN6501 or SN6505 transformer driver can be used to generate the isolated power. The transformer drivers provide efficiency between 60% to 75% as shown in 表 4.

表 4. Transformer Driver Efficiency at Lower Output Currents

OUTPUT VOLTAGE (V)	LOAD CURRENT (mA)	EFFICIENCY
4.022	8.4	61%
4.022	11.0	64%
4.022	19.0	71%
4.022	30.0	73%

### 2.3.11 Achieving Higher Efficiency With DC-DC Converters

表 5 provides details on the different DC-DC converters that can be used to generate a split rail output up to 12 V for an AC AIM with high efficiency.

表 5. DC-DC Converters for to Generate Isolated Split Rail Output

DEVICE	DESCRIPTION	APPLICATION NOTE
TPS61040	Boost converter to generate an 18-V output from a single-cell Li-Ion battery (3 to 4.2 V)	TPS61040EVM-001
LM5001	$\pm 5$ -V isolated, low-noise, split rail generator (0.25 A, 2.5 W total)	RD-171
LM5002	Low-noise, split rail, non-isolated power supply	RD-184
LM2733	9- to 14- $V_{IN}$ , isolated $\pm 15$ -V/100-mA output flyback reference design	PMP10703

### 2.3.12 Interface With High-Precision ADCs With Serial Interface

The digital isolators ISOW7841 or ISO7741 can be used to interface to ADCs, DACs, or other TI products with SPI. 表 6 provides some of the options for an ADC interface.

表 6. ADC to Interface With Data Acquisition Front-End With ISOW7841

SERIAL NUMBER	TI ADC PART	ADC DESCRIPTION	INTERFACE TYPE
1	ADS8688 or ADS8688A	16-Bit, 500-kSPS, 8-Channel, Single-Supply, SAR ADCs with Bipolar Input Ranges	SPI-compatible interface with daisy-chain
2	ADS8681	16-bit, 1-MSPS, 5-V SAR ADC with Integrated Analog Front-End and Bipolar Inputs	multiSPI™ interface with daisy-chain
3	ADS8588S, ADS8586S, ADS8584S, or ADS8578S	16-Bit, 200-kSPS, 8/6/4 Ch, Simultaneous-Sampling ADCs with Bipolar Inputs on a Single Supply	Serial interface
4	ADS131E08, ADS131E04, or ADS131E08S	Analog Front-End for Power Monitoring, Control, and Protection	SPI data interface
5	ADS131A04	24-Bit, 128-kSPS, 4-Ch, Simultaneous Sampling, Delta-Sigma ADC	Multiple SPI data interface modes

**表 6. ADC to Interface With Data Acquisition Front-End With ISOW7841 (continued)**

SERIAL NUMBER	TI ADC PART	ADC DESCRIPTION	INTERFACE TYPE
6	ADS131A02	24-Bit, 128-kSPS, 4-Ch, Simultaneous Sampling, Delta-Sigma ADC	Multiple SPI data interface modes

### 2.3.12.1 Voltage Supervisor Selection and Options

During an output overload condition, the output of the ISOW7841 reduces proportional to the output current. To ensure the MCU operates within a specified range, an external programmable-delay supervisory circuit can be considered. The TPS3808 has been provided in this reference design. 表 7 lists other devices that can be considered:

表 7. Voltage Supervisor Selections

SERIAL NUMBER	PART NUMBER	DESCRIPTION
1	TPS3836	Nano-power supervisory circuits
2	TPS3837	Nano-power supervisory circuits
3	TPS3838	Nano-power supervisory circuits
4	TPS3839	Ultra-low-power, supply voltage supervisor
5	TPS3820	Voltage monitor with watchdog timer

### 2.3.13 Increasing Gain Amplifier Voltage Output to $\pm 10.24$ V

To use the  $\pm 10.24$  range of the ADC with a gain amplifier, apply a  $\pm 12$ -V power supply to the gain amplifiers. The TPS65131 Positive and Negative Output DC-DC Converter can be used to generate the required power supplies. The RD-184 Low-Noise Split Rail Non-Isolated Power Supply works as well.

### 2.3.14 ADC Current Consumption

表 8 provides summary of the current consumption for different ADCs. The ISOW7841 can be used to power all the ADCs listed with high efficiency.

表 8. Power Consumption of Different ADCs

POWER (NOMINAL, MAX)	ADS8588S (mA)	ADS8688A (mA)	ADS8698 (mA)	ADS131E08, ADS131E08S (mA)	ADS131A04 (mA)
Analog , AVDD_DYN, internal ref	17.7, 24	13, 16	13, 16	5.8	4.0
DVDD	0.15, 0.3	0.5	0.5	1.0	0.8

### 2.3.15 ADC Measurement Performance With Higher Clock Frequency and Digital Isolator

In an isolated AC analog input module, the ADC and MCU are on opposite sides of the isolation barrier. The SCLK signal experiences a delay,  $t_{PD\_ISO}$ , as it travels from the MCU to the ADC. The ADC responds to the delayed version of SCLK with an SDO signal that experiences an additional delay of  $t_{PD\_ISO}$  as it arrives at the MCU. Therefore, the total skew between the SCLK edge and the corresponding ADC data bit at the MCU is ( $2 \times t_{PD\_ISO}$ ). This delay is acceptable as long as the data bit arrives at the MCU before the MCU performs a read operation.

In a standard SPI, a read event occurs on the opposite SCLK edge relative to the SCLK edge corresponding to a write event. For large values of  $f_{SCLK}$ , the  $t_{PD\_ISO}$  requirement becomes challenging to meet. To mitigate this issue, an additional delay of  $t_{PD\_ISO}$  is introduced in the already delayed version of SCLK by routing SCLK back across the isolation barrier to the MCU along with the SDO signal of the ADC through a multi-channel isolator. This rerouting results in minimal skew between the SDO and SCLK\_RET so that the MCU can capture SDO relative to SCLK\_RET without error. The following approaches can be used for returning SCLK across the isolation barrier.

### 2.3.15.1 ADS8681 Using Two Four-Channel Digital Isolators

図 8 provides the interface between the MCU and host interface by using multiple digital isolators.

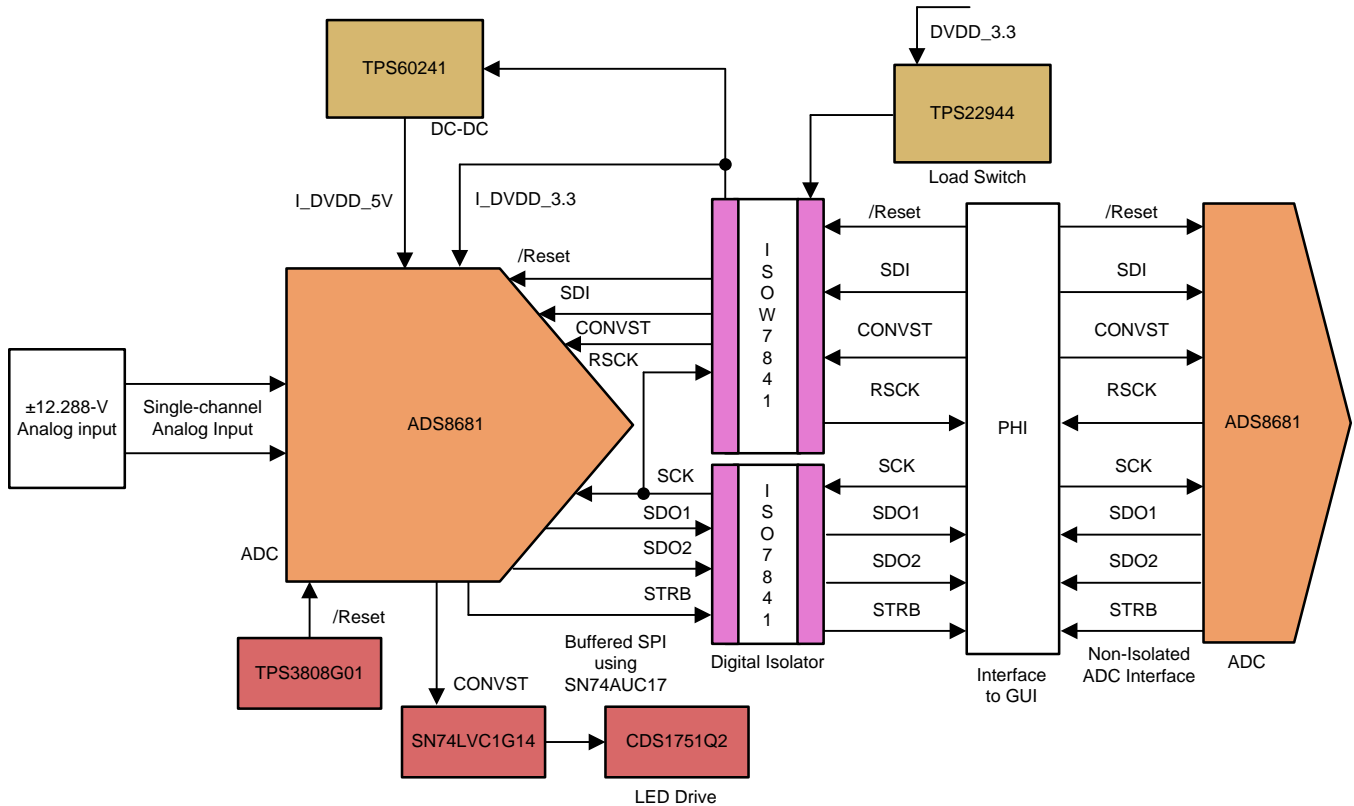

Copyright © 2017, Texas Instruments Incorporated

図 8. Block Diagram of ADS8681 Interface With SCK and RSCK Using Multiple Digital Isolators

表 9 provides the system performance with the SCLK returned back across the isolation barrier.

表 9. ADS8681 Performance With Clock Returned to Host From Isolated Side

TEST	INPUT RMS	INPUT RANGE	CH1 (500 KSPS) 60-Hz INPUT	CH1 (500 KSPS) 1-kHz INPUT	CH1 (1000 KSPS) 1-kHz INPUT
ENOB	8.2 V	±12.288 V	14.973	14.951	14.913
SNR	8.2 V	±12.288 V	91.913	91.825	91.630
THD	8.2 V	±12.288 V	-116.866	-110.437	-108.239

### 2.3.15.2 ADS8920B Using Single Digital Isolator With Integrated Power

図 9 provides the interface between the ADC and host interface by a single digital isolator with the ADC using default configuration.

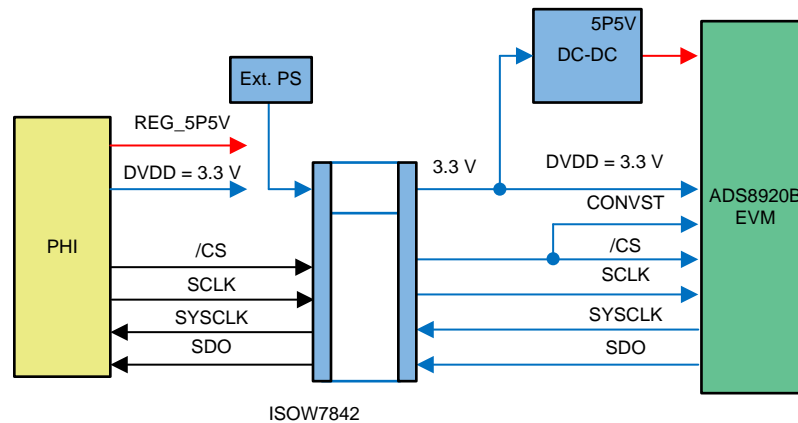

Copyright © 2017, Texas Instruments Incorporated

図 9. Block Diagram of ADS8920B Interface Using Single Digital Isolator

表 10 provides the system performance with the SCLK returned back across the isolation barrier.

表 10. ADS8920B Measurement Performance With Clock Fold Back

CONFIGURATION	INPUT FREQ	SNR (dB)	THD (dB)
ADS8920BEVM-PDK	2 kHz	96.10	-125.21
ADS8920BEVM-PDK + ISOW Adapter	2 kHz	96.05	-124.64
ADS8920BEVM-PDK + ISOW Adapter	50 Hz	96.16	-119.31

### 2.3.16 Temperature Compensation of Measured Analog Input for Improved Measurement Accuracy

The auxiliary ADC channel of the ADS8688 or ADS8668 can be used to measure ambient temperature for real-time compensation of the measured electrical parameters. There are two approaches to measure temperature.

#### 2.3.16.1 Onboard High-Accuracy Analog Temperature Sensor Interface

The first approach is to use an onboard high-accuracy analog temperature sensor interface. 表 11 provides details of different sensors that can be considered for interfacing to the auxiliary channel of ADC.

表 11. High-Accuracy Analog Temperature for Sensor for AC AIM

SENSOR	DESCRIPTION
LMT70	±0.1°C precision analog temperature sensor
LM35	±0.5°C temperature sensor with analog output with 30-V capability

### 2.3.16.2 Using Remote Temperature Sensor

The second approach is to use a remote temperature sensor, including resistance temperature detectors (RTDs). 表 12 lists some of the common types of RTDs used:

表 12. Common RTD Sensors for AC AIM

SENSOR	DESCRIPTION
100 Ω PT	Platinum
120 Ω NI	Nickel
10 Ω CU	Copper

This reference design provides provision to measure RTD input. The same auxiliary ADC input can be configured to measure the analog temperature sensor output.

### 2.3.17 Improving Analog Input Measurement Accuracy Using 18-Bit ADC

The measurement accuracy of the AC AIM can be increased by using external precision gain amplifier or higher resolution ADC or combination of both. Precision gain amplifiers like OPA4180 or OPA4180 or INA188 can be used for providing the required gain. ADS8698 18-Bit SAR ADC can be used for measurement of analog input with higher resolution resulting in improved measurement accuracy.

### 2.3.18 Design of wide input AC or DC Digital, Contact, or Binary Input Module

The TIDA-00847 reference design showcases a DC or DC BIM using a 10-bit SAR ADC internal to the MCU MSP430G2332. Most grid applications allow measurements of 16 digital or binary inputs with a DC voltage up to 300 V. The ADS8668 connected in a daisy-chain configuration with a 12-bit resolution can be used to implement a 16-channel group isolated DC BIM using only four TI products with improved accuracy performance over a wide input range.

### 2.3.19 DC Transducer Input Module With Unidirectional or Bidirectional Signal Input

This reference design can be designed as a DC AIM to measure unipolar or bipolar inputs ranging from 0 to 20 mA, 4 to 20 mA, 0 to 10 V, ±20 mA, and ±10 V. Similar reference designs include the [TIDA-00550](#), [TIDA-00764](#), [TIDA-00164](#), [TIDA-00119](#), and [TIDA-00310](#). This reference design with an integrated digital isolator and power converter simplifies the module design.

### 3 Hardware, Testing Requirements, and Test Results

#### 3.1 Required Hardware

This section describes the setup for testing the AC AIM.

##### 3.1.1 AC AIM

The following subsections provide information on the different interface connectors for connecting power supply, host interface, and AC analog inputs.

##### 3.1.1.1 Eight-Channel ADS8688 AC AIM

表 13 provides details on the different connectors for performance evaluation of the AC AIM.

**表 13. Eight-Channel ADS8688 AIM Connections**

CONNECTOR	FUNCTION	COMMENTS
J1, J8	Eight analog inputs to ADC channel 0 to 7	Do not exceed $\pm 10.24$ -V inputs for proper performance
J19	PHI interface	For connecting the AC AIM to GUI
J12	DC supply input	3.3 V

##### 3.1.1.2 Eight-Channel ADS8668 AC AIM

表 14 provides details on the different connectors to evaluate the performance of the AC AIM.

**表 14. Eight-Channel 12-Bit ADS8668 AIM Connections**

CONNECTOR	FUNCTION	COMMENTS
J8	Four analog inputs to ADC channel 2 to 5	Do not exceed $\pm 10.24$ -V inputs for proper performance
J7, J10, J11, J13	Four analog inputs to ADC channel 0, 1, 6, and 7 with gain amplifier	Do not exceed 333-mV inputs for proper performance
J19	PHI interface	For connecting the AC AIM to GUI
J12	DC supply input	3.3 V

##### 3.1.1.3 16-Channel AC AIM

For the ADS8688 daisy-chained AC AIM with SPI and analog input connections, see the [TIDA-00307](#) design for details on input connections.



## 3.2 Testing and Results

### 3.2.1 Test Setup

☒ 10 provides information on the setup used for functional and performance testing of the AC AIM.

The test setup for the AC AIM consists of:

- DC power supply (3.3 V)
- TIDA-01214 reference design board
- Function generator to simulate the AC analog inputs,  $\pm 10.24$  max input
- Serial data capture card (SDCC) interface card for HMI
- GUI for data capture

注: While testing, ensure the analog inputs do not exceed the ADC input range of  $\pm 10.24$  V for proper operation.

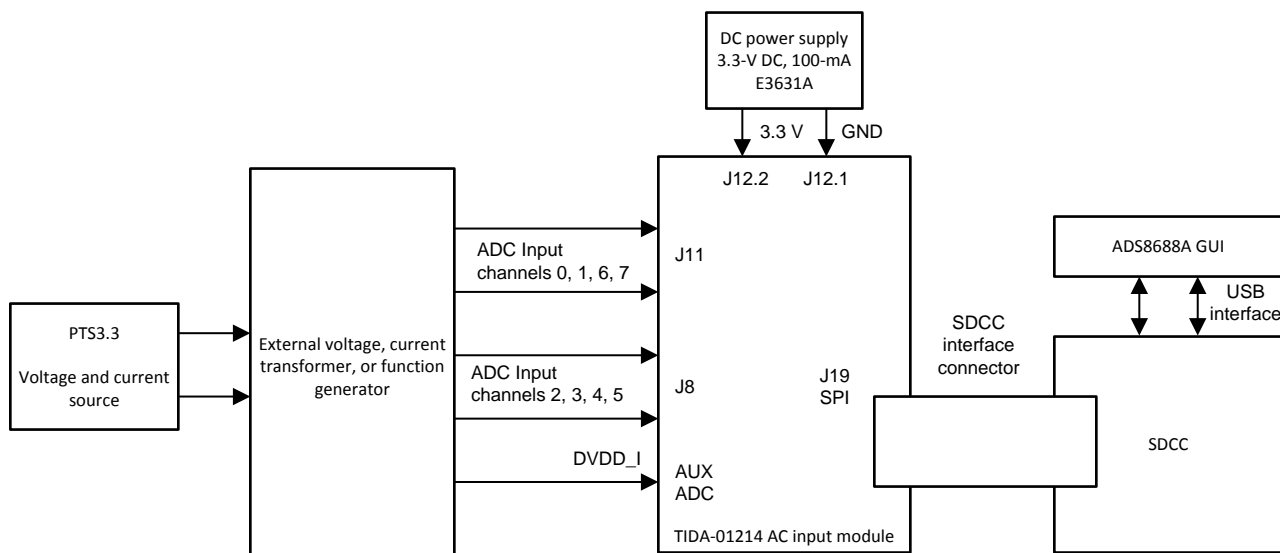

Copyright © 2017, Texas Instruments Incorporated

☒ 10. Test Setup for Performance Testing of AC AIM

### 3.2.2 GUI for Performance Testing

The GUI of the relevant device (ADS8688 or ADS8668) and SDCC board are used to evaluate the performance of this reference design. Install the ADS86xxEVM-PDK GUI provided on the [ADS8688A evaluation module page](#) to evaluate the performance of this reference design along with the SDCC interface card connected to the computer. To test the ADS8688A configured in daisy chain, the custom GUI is used. Contact TI for the GUI requirements to test daisy chaining configuration. As a lowest cost option, [ADS7042 Ultra-Low-Power Ultra-Small-Size 12-Bit 1MSPS SAR ADC Performance Demonstration Kit \(PDK\)](#) can be ordered. This EVM is shipped with an SDCC card.

### 3.2.3 Test Results

Note the following test conditions for performance measurement of the AC AIM:

- The tests are done using a function generator or programmable AC voltage and current source.
- GUI is for performance evaluation.

#### 3.2.3.1 Functional Testing

表 15 provides details on the different functional tests that are done on the BIMs.

表 15. AC AIM Functional Test Observations

PARAMETER	SPECIFICATION	MEASUREMENT
Isolated supply ISOW7841 output	3.3 V	3.36
Output ripple on isolated supply for ISOW7841	100 mV	≈ 100 mV
Transformer driver-based isolated supply	3.3 V	3.32 V
3.3- to 5-V DC-DC converter	5 V	5 V
ISOW7841-based digital isolator functionality	Communication functionality	OK
Digital isolator functionality	Communication functionality	OK
ADC analog inputs measurement	Measurement of inputs RMS and display	OK
Frequency measurement	50 or 60 Hz	OK
Alarm function	Based on set high and low thresholds	OK
Alarm output LED	Alarm indication and reset	OK
Diagnostics	Output of auxiliary channel	OK
Host	SDCC interface to the AC AIM	OK

#### 3.2.3.2 ADC Performance

##### 3.2.3.2.1 ADS8688 Measurement Performance

表 16 provides performance test results for the ADS8688 with different input ranges.

表 16. ADS8688-Based AC AIM measurement Performance

TESTS	INPUT	INPUT RANGE (V)	CH1	CH7
ENOB	7.0000	±10.24	14.90	14.90
	3.5000	±5.12	14.77	14.77
	1.7500	±2.56	14.51	14.51
	0.8750	±1.28	13.64	13.63
	0.4375	±0.64	12.69	12.70
SNR	7.0000	±10.24	91.47	91.51
	3.5000	±5.12	90.66	90.70
	1.7500	±2.56	89.11	89.12
	0.8750	±1.28	83.87	83.83
	0.4375	±0.64	78.14	78.23
THD	7.0000	±10.24	-111.02	-112.64
	3.5000	±5.12	-111.06	-112.90
	1.7500	±2.56	-111.26	-112.90
	0.8750	±1.28	-106.44	-106.29
	0.4375	±0.64	-99.82	-101.74

### 3.2.3.2.2 Test Results for ADS8688 Daisy Chain Synchronization

Two ADS8688A ADCs (ADC1 and ADC2) are daisy chained to achieve simultaneous sampling between the same channels of two ADCs. 表 17 summarizes the phase error observed between channels of ADC1 and ADC2.

**表 17. Phase Difference Between Input Channels of Two ADCs in Daisy Chain Mode**

ADC1 CHANNELS	ADC2 CHANNELS	PHASE DIFFERENCE (MIN)
CH0	CH0	0.48
CH1	CH1	0.48
CH2	CH2	0.54
CH3	CH3	0.54
CH4	CH4	0.54
CH5	CH5	0.54
CH6	CH6	0.48
CH7	CH7	0.48

**注:** While converting phase error from degrees to minutes, 1 degree is equal to 60 minutes. At a power factor of 0.5 Lag (Inductive, 60 degree), a 0.5-minute error contributes to 0.03% or less measurement error, which falls within the measurement uncertainty. During measurement, there is phase shift between channels of the same ADC due to the multiplexed ADC sampling architecture. These errors can also be compensated.

To compensate for the phase shift introduced by multiplexed ADC, see the [TIPD167 TI Verified Design](#) for more details.

表 18 provides the results of a phase error after compensation with ADC1 channel 0 as the reference.

**表 18. Phase Shift of ADC1 and ADC2 Input Channels With ADC1 Channel 0 as Reference**

ADC CHANNELS	PHASE DIFFERENCE (MIN)
ADC1 Channel 1	< 0.1
ADC1 Channel 2	< 0.1
ADC1 Channel 3	< 0.1
ADC1 Channel 4	< 0.1
ADC1 Channel 5	< 0.1
ADC1 Channel 6	< 0.1
ADC1 Channel 7	< 0.1
ADC2 Channel 0	< 0.4
ADC2 Channel 1	< 0.4
ADC2 Channel 2	< 0.4
ADC2 Channel 3	< 0.4
ADC2 Channel 4	< 0.4
ADC2 Channel 5	< 0.4
ADC2 Channel 6	< 0.4
ADC2 Channel 7	< 0.4

In the reference design hardware implementation, series resistors, protection diodes, and filter capacitors have been provided for protection and input noise filtering. Based on the phases shift requirements, these components values can change, or some of these may have to be de-populated. The phase error between the ADCs can be further reduced by using a common external reference.

The phase error testing is done with the ADC samples taken at maximum device sampling rate with ADC1 and ADC2 SDO output interfaced to the host separately. ADCs can be also configured in daisy chain mode to expand the input channels using only one interface. The phase error depends on the ADC sampling rate.

### 3.2.3.3 ISOW7841 Isolated Power Supply Testing

#### 3.2.3.3.1 ISOW7841 Load Regulation Testing

Load regulation is tested by varying the output load from 20 to 100 mA and an input of 3.3 V applied at the input of the power connector. 表 19 provides the test results for load regulation.

表 19. ISOW7841 Load Regulation Test<sup>(1)</sup>

INPUT VOLTAGE (V)	INPUT I (SUBTRACTING NO LOAD I) (A)	POWER	OUTPUT VOLTAGE (V)	OUTPUT CURRENT (A)	POWER (W)	EFFICIENCY	OBSERVATIONS	LOAD (R)
3.3	0.057	0.188	3.340	0.022	0.073	39.064%	—	150
3.3	0.081	0.267	3.340	0.033	0.112	41.734%	—	100
3.3	0.101	0.333	3.364	0.044	0.148	44.409%	—	75
3.3	0.124	0.409	3.364	0.055	0.185	45.215%	—	150 100
3.3	0.144	0.475	3.364	0.067	0.225	47.289%	—	150 75
3.3	0.168	0.554	3.364	0.078	0.262	47.268%	—	100 75
3.3	0.184	0.607	3.364	0.085	0.285	46.876%	—	39
3.3	0.262	0.865	3.380	0.122	0.413	47.772%	—	27
3.3	0.254	0.838	3.043	—	—	—	Overcurrent clamp	22

<sup>(1)</sup> No load input current: 0.026 A

Observation: Load regulation observed was < ±1%.

#### 3.2.3.3.2 ISOW7841 Line Regulation (Input versus Output Voltage Variation) Testing

Line regulation is tested by varying voltage from 3.6 to 2.3 V with an approximate 80-mA load at the output of the power connector. 表 20 provides the test results for line regulation.

表 20. Line Regulation (Input versus Output Voltage Variation) and UVLO

VOLTAGE (V)		CURRENT (A)		EFFICIENCY	LOAD in RR	SUPPLY I (A)	OBSERVATIONS
INPUT	OUTPUT	OUTPUT I	INPUT I				
3.6	3.363	0.086	0.174	49.55%	39	0.200	—
3.3	3.360	0.086	0.184	46.82%	39	0.210	—
3.0	3.373	0.086	0.201	43.02%	39	0.227	—
2.7	3.380	0.086	0.229	37.84%	39	0.255	—
2.6	3.330	0.085	0.231	36.96%	39	0.257	UVLO recover
2.5	3.200	0.082	0.222	36.96%	39	0.248	—
2.4	3.000	0.076	0.214	35.94%	39	0.240	—
2.3	0	—	—	—	—	0	UVLO

Observation: Line regulation observed was < ±3 mV/V.

### 3.2.3.3.3 ISOW7841 Ripple Measurement

Figure 11 shows a DC output ripple in mV on isolated supply (pkpk) with a 20-MHz bandwidth,  $C_{LOAD} = 20 \mu F$ ,  $I_{ISO} = 80 \text{ mA}$ . The measurements are done near to the load, away from the ISOW7841 power output pins.

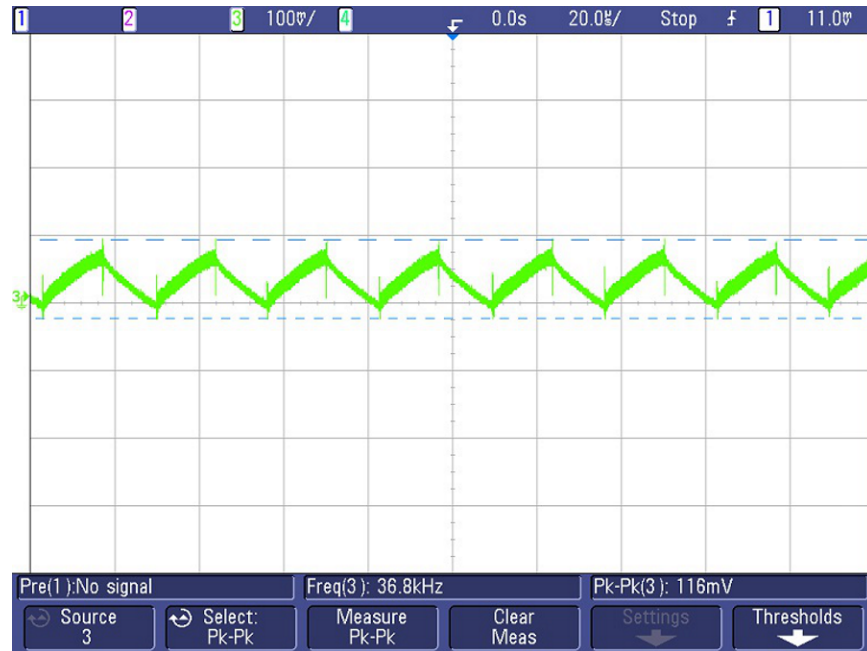

Figure 11. ISOW7841 DC Output Ripple

### 3.2.3.3.4 ISOW7841 Input Switching Current

Figure 12 shows the input switching current measured for a DC input current of 160 mA. The input voltage applied is 3.3-V DC.



図 12. ISOW7841 Input Switching Current for 75-mA Output Loading

### 3.2.3.3.5 ISOW7841 Device Hotspot Monitoring

The output of the ISOW7841 is loaded for 80 mA, and the hotspot is monitored after 30 minutes. 図 13 shows the hotspot measurements on the ISOW784x evaluation module.

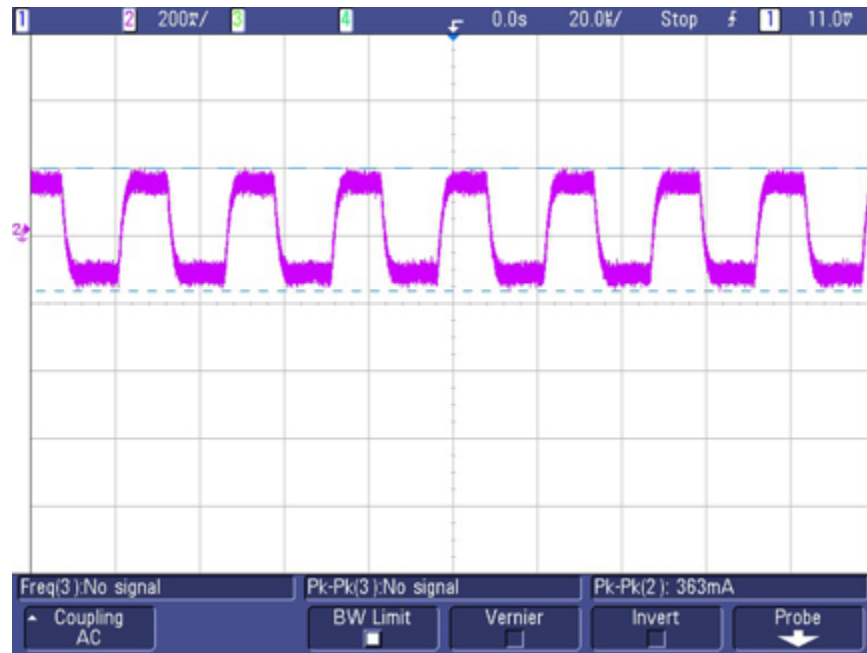

図 13. ISOW7841 Hotspot Capture With 80-mA Load

### 3.2.3.4 Test Results Summary for AC AIM

表 21 summarizes the tests and observations for the AC AIM.

**表 21. Test Results Summary**

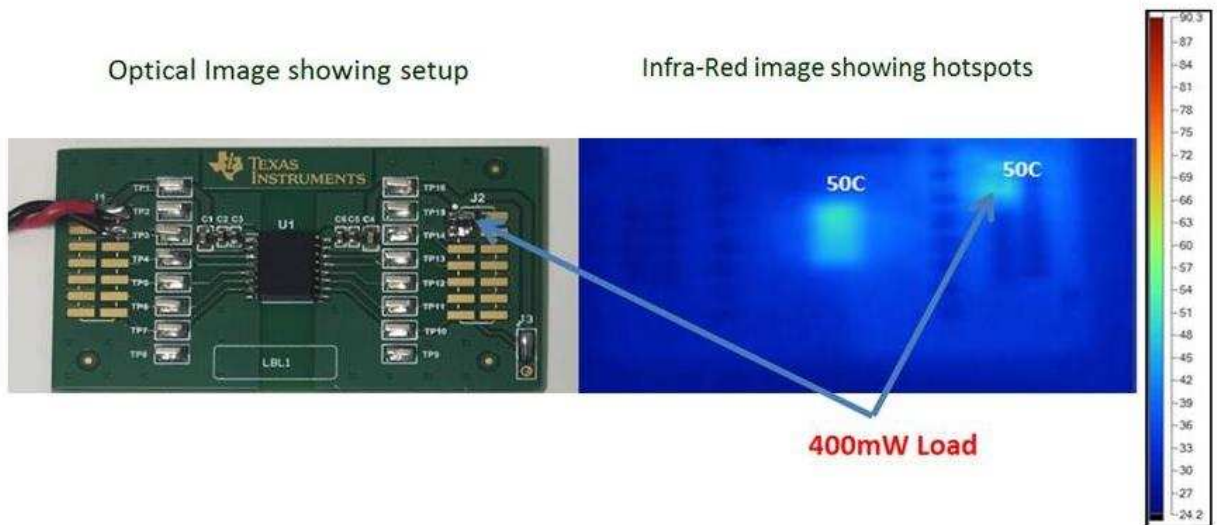
TEST	OBSERVATION
ADC functionality	OK
ADC performance	OK
ISOW7841 output	OK
Digital isolator interface	OK
Transformer driver output	OK
DC-DC and LDO output	OK
Load switch and POR operation	OK
Gain amplifier output	OK
Diagnostics LEDs	OK
ADC aux channel testing	OK
Host interface with reinforced digital isolation	OK

## 4 Design Files

### 4.1 Schematics

To download the schematics, see the design files at [TIDA-01214](#).

### 4.2 Bill of Materials

To download the bill of materials (BOM), see the design files at [TIDA-01214](#).

### 4.3 PCB Layout Recommendations

#### 4.3.1 Layout Prints

To download the layer plots, see the design files at [TIDA-01214](#).

### 4.4 Altium Project

To download the Altium project files, see the design files at [TIDA-01214](#).

### 4.5 Gerber Files

To download the Gerber files, see the design files at [TIDA-01214](#).

### 4.6 Assembly Drawings

To download the assembly drawings, see the design files at [TIDA-01214](#).

## 5 Related Documentation

1. Texas Instruments, [16-Bit 1-MSPS Data Acquisition System With Isolated Inputs for High-Voltage Common-Mode Rejection](#), TIDA-00106 Design Guide (TIDUBJ1)
2. Texas Instruments, [20-Bit, 1-MSPS Isolator Optimized Data Acquisition Reference Design Maximizing SNR and Sample Rate](#), TIDA-01037 Design Guide (TIDUCM8)
3. Texas Instruments, [Size and Cost-Optimized Binary Input Module Reference Design Using Digital Isolator With Integrated Power](#), TIDA-00847 Design Guide (TIDUCX3)
4. Texas Instruments, [Low-Emission Designs With ISOW7841 Integrated Signal and Power Isolator](#), Application Report (SLLA368)
5. Texas Instruments, [Eight-Channel, Isolated, High-Voltage Analog Input Module With ISOW7841 Reference Design](#), TIDA-01333 Design Guide (TIDUCU4)

### 5.1 商標

E2E, multiSPI are trademarks of Texas Instruments.  
すべての商標および登録商標はそれぞれの所有者に帰属します。

## 6 Terminology

**AIM**— Analog input module

**BIM**— Binary input module

**RTD**— Resistance temperature detectors

**AC** — Alternating current

**DC** — Direct current

**SDCC**— Serial data capture card



## 7 About the Authors

**KALLIKUPPA MUNIYAPPA SREENIVASA** is a systems architect at Texas Instruments where he is responsible for developing reference design solutions for the industrial segment. Sreenivasa brings to this role his experience in high-speed digital and analog systems design. Sreenivasa earned his bachelor of engineering (BE) in electronics and communication engineering (BE-E&C) from VTU, Mysore, India.

**AMIT KUMBASI** is a systems architect at Texas Instruments Dallas where he is responsible for developing subsystem solutions for Grid Infrastructure within Industrial Systems. Amit brings to this role his expertise with defining products, business development, and board level design using precision analog and mixed-signal devices. He holds a master's in ECE (Texas Tech) and an MBA (University of Arizona).

## 改訂履歴

資料番号末尾の英字は改訂を表しています。その改訂履歴は英語版に準じています。

2017年9月発行のものから更新

Page

- 
- ブロック図でISOWATTをISOW78xxに変更..... 2
-

## 重要なお知らせと免責事項

TI は、技術データと信頼性データ(データシートを含みます)、設計リソース(リファレンス・デザインを含みます)、アプリケーションや設計に関する各種アドバイス、Web ツール、安全性情報、その他のリソースを、欠陥が存在する可能性のある「現状のまま」提供しており、商品性および特定目的に対する適合性の黙示保証、第三者の知的財産権の非侵害保証を含むいかなる保証も、明示的または黙示的にかかわらず拒否します。

これらのリソースは、TI 製品を使用する設計の経験を積んだ開発者への提供を意図したものです。(1) お客様のアプリケーションに適した TI 製品の選定、(2) お客様のアプリケーションの設計、検証、試験、(3) お客様のアプリケーションが適用される各種規格や、その他のあらゆる安全性、セキュリティ、またはその他の要件を満たしていることを確実にする責任を、お客様のみが単独で負うものとします。上記の各種リソースは、予告なく変更される可能性があります。これらのリソースは、リソースで説明されている TI 製品を使用するアプリケーションの開発の目的でのみ、TI はその使用をお客様に許諾します。これらのリソースに関して、他の目的で複製することや掲載することは禁止されています。TI や第三者の知的財産権のライセンスが付与されている訳ではありません。お客様は、これらのリソースを自身で使用した結果発生するあらゆる申し立て、損害、費用、損失、責任について、TI およびその代理人を完全に補償するものとし、TI は一切の責任を拒否します。

TI の製品は、TI の販売条件 ([www.tij.co.jp/ja-jp/legal/termsofsale.html](http://www.tij.co.jp/ja-jp/legal/termsofsale.html))、または [ti.com](http://ti.com) やかかる TI 製品の関連資料などのいずれかを通じて提供する適用可能な条項の下で提供されています。TI がこれらのリソースを提供することは、適用される TI の保証または他の保証の放棄の拡大や変更を意味するものではありません。

Copyright © 2018, Texas Instruments Incorporated  
日本語版 日本テキサス・インスツルメンツ株式会社

## 重要なお知らせと免責事項

TI は、技術データと信頼性データ(データシートを含みます)、設計リソース(リファレンス・デザインを含みます)、アプリケーションや設計に関する各種アドバイス、Web ツール、安全性情報、その他のリソースを、欠陥が存在する可能性のある「現状のまま」提供しており、商品性および特定目的に対する適合性の黙示保証、第三者の知的財産権の非侵害保証を含むいかなる保証も、明示的または黙示的にかかわらず拒否します。

これらのリソースは、TI 製品を使用する設計の経験を積んだ開発者への提供を意図したものです。(1) お客様のアプリケーションに適した TI 製品の選定、(2) お客様のアプリケーションの設計、検証、試験、(3) お客様のアプリケーションが適用される各種規格や、その他のあらゆる安全性、セキュリティ、またはその他の要件を満たしていることを確実にする責任を、お客様のみが単独で負うものとします。上記の各種リソースは、予告なく変更される可能性があります。これらのリソースは、リソースで説明されている TI 製品を使用するアプリケーションの開発の目的でのみ、TI はその使用をお客様に許諾します。これらのリソースに関して、他の目的で複製することや掲載することは禁止されています。TI や第三者の知的財産権のライセンスが付与されている訳ではありません。お客様は、これらのリソースを自身で使用した結果発生するあらゆる申し立て、損害、費用、損失、責任について、TI およびその代理人を完全に補償するものとし、TI は一切の責任を拒否します。

TI の製品は、TI の販売条件 ([www.tij.co.jp/ja-jp/legal/termsofsale.html](http://www.tij.co.jp/ja-jp/legal/termsofsale.html))、または [ti.com](http://ti.com) やかかる TI 製品の関連資料などのいずれかを通じて提供する適用可能な条項の下で提供されています。TI がこれらのリソースを提供することは、適用される TI の保証または他の保証の放棄の拡大や変更を意味するものではありません。

Copyright © 2018, Texas Instruments Incorporated  
日本語版 日本テキサス・インスツルメンツ株式会社