



Table of Contents

1 Overview	2
2 Functional Safety Failure In Time (FIT) Rates	3
3 Failure Mode Distribution (FMD)	4
4 Pin Failure Mode Analysis (Pin FMA)	5
5 Revision History	8

Trademarks

All trademarks are the property of their respective owners.

1 Overview

This document contains information for TPSI3052-Q1 (SOIC package) to aid in a functional safety system design. Information provided are:

- Functional Safety Failure In Time (FIT) rates of the semiconductor component estimated by the application of industry reliability standards
- Pin failure mode analysis (Pin FMA)

Figure 1-1 shows the device functional block diagram for reference.

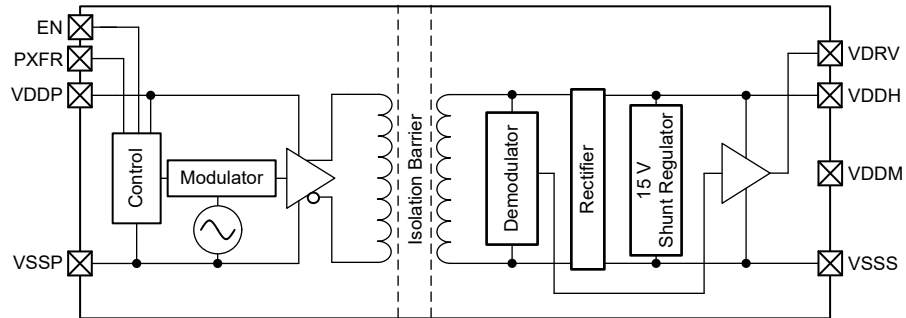

Figure 1-1. Functional Block Diagram

TPSI3052-Q1 was developed using a quality-managed development process, but was not developed in accordance with the IEC 61508 or ISO 26262 standards.

2 Functional Safety Failure In Time (FIT) Rates

This section provides Functional Safety Failure In Time (FIT) rates for TPSI3052-Q1 based on two different industry-wide used reliability standards:

- [Table 2-1](#) provides FIT rates based on IEC TR 62380 / ISO 26262 part 11
- [Table 2-2](#) provides FIT rates based on the Siemens Norm SN 29500-2

Table 2-1. Component Failure Rates per IEC TR 62380 / ISO 26262 Part 11

FIT IEC TR 62380 / ISO 26262	FIT (Failures Per 10 ⁹ Hours)
Total Component FIT Rate	19
Die FIT Rate	4
Package FIT Rate	15

The failure rate and mission profile information in [Table 2-1](#) comes from the Reliability data handbook IEC TR 62380 / ISO 26262 part 11:

- Mission Profile: Motor Control from Table 11
- Power dissipation: 250 mW
- Climate type: World-wide Table 8
- Package factor (lambda 3): Table 17b
- Substrate Material: FR4
- EOS FIT rate assumed: 0 FIT

Table 2-2. Component Failure Rates per Siemens Norm SN 29500-2

Table	Category	Reference FIT Rate	Reference Virtual T _J
5	CMOS/BICMOS ASICs Analog & Mixed = < 50-V supply	25 FIT	55°C

The Reference FIT Rate and Reference Virtual T_J (junction temperature) in [Table 2-2](#) come from the Siemens Norm SN 29500-2 tables 1 through 5. Failure rates under operating conditions are calculated from the reference failure rate and virtual junction temperature using conversion information in SN 29500-2 section 4.

3 Failure Mode Distribution (FMD)

The failure mode distribution for TPSI3052-Q1 in [Table 3-1](#) comes from the combination of common failure modes listed in standards such as IEC 61508 and ISO 26262, the ratio of sub-circuit function size and complexity and from best engineering judgment.

The failure modes listed in this section reflect random failure events and do not include failures due to misuse or overstress.

Table 3-1. Die Failure Modes and Distribution

Die Failure Modes	Failure Mode Distribution (%)
VDDH/VDDM rails fail to power up. VDRV remains low.	15%
VDRV does not respond to EN signaling.	20%
Output power not meeting specification. Longer VDDH/VDDM start-up and recovery times.	25%
VDDH not regulated, potential device damage	15%
VDRV propagation times longer than specified	5%
VDRV only stays high for few microseconds due to improper loading of configuration.	5%
Higher EMI	5%
Unpredictable power down sequence	5%
VDRV output held high	5%

4 Pin Failure Mode Analysis (Pin FMA)

This section provides a Failure Mode Analysis (FMA) for the pins of the TPSI3052-Q1. The failure modes covered in this document include the typical pin-by-pin failure scenarios:

- Pin short-circuited to Ground (see [Table 4-2](#))
- Pin open-circuited (see [Table 4-3](#))
- Pin short-circuited to an adjacent pin (see [Table 4-4](#))
- Pin short-circuited to supply (see [Table 4-5](#))

[Table 4-2](#) through [Table 4-5](#) also indicate how these pin conditions can affect the device as per the failure effects classification in [Table 4-1](#).

Table 4-1. TI Classification of Failure Effects

Class	Failure Effects
A	Potential device damage that affects functionality
B	No device damage, but loss of functionality
C	No device damage, but performance degradation
D	No device damage, no impact to functionality or performance

[Figure 4-1](#) shows the TPSI3052-Q1 pin diagram. For a detailed description of the device pins please refer to the *Pin Configuration and Functions* section in the TPSI3052-Q1 data sheet.

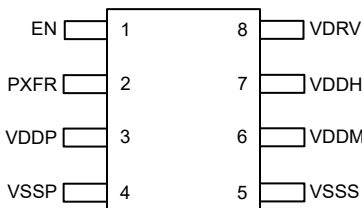

Figure 4-1. Pin Diagram

The TPSI3052-Q1 is normally operated in one of two modes of operation for a given application: three-wire mode or two-wire mode. The Pin FMA was performed individually for each of these modes of operation in the following sections.

Three-Wire Mode

Following are the assumptions of use and the device configuration assumed for the pin FMA in this section:

- Device configured and operating in three-wire mode
- Device in normal operation prior to any open or short condition being applied to the respective pin
- EN set to a static logic low or high (VDRV asserted low or high respectively)
- Opens or shorts occur relative to primary and secondary sides of the device and is a static event

Table 4-2. Three-Wire Mode: Pin FMA for Device Pins Short-Circuited to VSSP or VSSS

Pin Name	Pin No.	Ground	Description of Potential Failure Effect(s)	Failure Effect Class
EN	1	VSSP	VDRV asserted low	B
PXFR	2	VSSP	Subsequent power cycles result in R_{PXFR} selection to 7.32 k Ω , which can result in longer start-up and recovery times if different R_{PXFR} from 7.32 k Ω was used in the application.	C
VDDP	3	VSSP	No power transfer. VDDH and VDDM rail collapse. VDRV asserted low with active clamp enabled. If EN static is high, additional leakage current into EN pin is observed on the order of 25 mA.	B
VDRV	8	VSSS	If VDRV was high, VDDH and VDDM rail collapse. VDRV asserts low with active clamp enabled. If VDRV was low, no effect.	B
VDDH	7	VSSS	VDDH and VDDM rail collapse. VDRV asserted low with active clamp enabled.	B

Table 4-2. Three-Wire Mode: Pin FMA for Device Pins Short-Circuited to VSSP or VSSS (continued)

Pin Name	Pin No.	Ground	Description of Potential Failure Effect(s)	Failure Effect Class
VDDM	6	VSSS	VDDH and VDDM rail collapse. VDRV asserted low with active clamp enabled.	B

Table 4-3. Three-Wire Mode: Pin FMA for Device Pins Open-Circuited

Pin Name	Pin No.	Description of Potential Failure Effect(s)	Failure Effect Class
EN	1	VDRV asserted low. EN pin has an internal resistive pull-down to VSSP.	B
PXFR	2	Subsequent power cycles result in R_{PXFR} selection to 7.32 k Ω , which can result in longer start-up and recovery times if different R_{PXFR} from 7.32 k Ω was used in the application.	C
VDDP	3	No power transfer. VDDH and VDDM rail collapse. VDRV asserted low with active clamp enabled.	B
VSSP	4	No power transfer. VDDH and VDDM rail collapse. VDRV asserted low with active clamp enabled.	B
VDRV	8	No drive to external switch. External switch gate control can float dependent upon application circuitry.	B
VDDH	7	VDDH can collapse under loading or switching events.	B
VDDM	6	VDDH and VDDM can collapse under loading or switching events.	B
VSSS	5	Normal power transfer. VDDH and VDDM rails remain charged. VDRV follows state of EN logic level. Because VSSS is a floating ground, it cannot drive external switch.	B

Table 4-4. Three-Wire Mode: Pin FMA for Device Pins Short-Circuited to Adjacent Pin

Pin Name	Pin No.	Shorted to	Description of Potential Failure Effect(s)	Failure Effect Class
VDDH	7	VDDM	VDDH and VDDM rail collapse. VDRV asserted low with active clamp enabled.	B
VDRV	8	VDDH	If VDRV was low, VDDH and VDDM rail collapse. VDRV remains low with active clamp enabled. If VDRV was high, no effect.	B
EN	1	PXFR	Subsequent power cycles result in R_{PXFR} selection to 7.32 k Ω , which can result in longer start-up and recovery times if different R_{PXFR} from 7.32 k Ω was used in the application.	C

Table 4-5. Three-Wire Mode: Pin FMA for Device Pins Short-Circuited to VDDP

Pin Name	Pin No.	Description of Potential Failure Effect(s)	Failure Effect Class
EN	1	For standard enable devices, VDRV asserted high. For one-shot enable devices, VDRV asserted high, then remains asserted low	B
PXFR	2	Subsequent power cycles result in R_{PXFR} selection to 7.32 k Ω , which can result in longer start-up and recovery times if different R_{PXFR} from 7.32 k Ω was used in the application.	C

Two-Wire Mode

Following are the assumptions of use and the device configuration assumed for the pin FMA in this section:

- Device configured and operating in two-wire mode
- Device in normal operation prior to any open or short condition being applied to the respective pin
- EN set to a static high (VDRV asserted high)
- Opens or shorts occur relative to primary and secondary sides of the device and is a static event

Table 4-6. Two-Wire Mode: Pin FMA for Device Pins Short-Circuited to VSSP or VSSS

Pin Name	Pin No.	Ground	Description of Potential Failure Effect(s)	Failure Effect Class
EN	1	VSSP	No power transfer. VDDH and VDDM rail collapse. VDRV asserted low with active clamp enabled.	B
PXFR	2	VSSP	Subsequent power cycles result in R_{PXFR} selection to 7.32 k Ω , which can result in longer start-up and recovery times if different R_{PXFR} from 7.32 k Ω was used in the application.	C
VDDP	3	VSSP	No power transfer. VDDH and VDDM rail collapse. VDRV asserted low with active clamp enabled. Additional leakage current into EN pin will be observed on the order of 25 mA.	B
VDRV	8	VSSS	VDDH and VDDM rail collapse. VDRV asserts low with active clamp enabled.	B
VDDH	7	VSSS	VDDH and VDDM rail collapse. VDRV asserted low with active clamp enabled.	B
VDDM	6	VSSS	VDDH and VDDM rail collapse. VDRV asserted low with active clamp enabled.	B

Table 4-7. Two-Wire Mode: Pin FMA for Device Pins Open-Circuited

Pin Name	Pin No.	Description of Potential Failure Effect(s)	Failure Effect Class
EN	1	No power transfer. VDDH and VDDM rail collapse. VDRV asserted low with active clamp enabled. EN pin has an internal resistive pulldown to VSSP.	B
PXFR	2	Subsequent power cycles result in R_{PXFR} selection to 7.32 k Ω , which can result in longer start-up and recovery times if different R_{PXFR} from 7.32 k Ω was used in the application.	C
VDDP	3	No power transfer. VDDH and VDDM rail collapse. VDRV asserted low with active clamp enabled.	B
VSSP	4	No power transfer. VDDH and VDDM rail collapse. VDRV asserted low with active clamp enabled.	B
VDRV	8	No drive to external switch. External switch gate control can float dependent upon application circuitry.	B
VDDH	7	VDDH can collapse under loading or switching events.	B
VDDM	6	VDDH and VDDM can collapse under loading or switching events.	B
VSSS	5	Normal power transfer. VDDH and VDDM rails remain charged. VDRV follows state of EN logic level. Because VSSS is a floating ground, it cannot drive external switch.	B

Table 4-8. Two-Wire Mode: Pin FMA for Device Pins Short-Circuited to Adjacent Pin

Pin Name	Pin No.	Shorted to	Description of Potential Failure Effect(s)	Failure Effect Class
VDDH	7	VDDM	VDDH and VDDM rail collapse. VDRV asserted low with active clamp enabled.	B
VDRV	8	VDDH	VDRV remains high.	B
EN	1	PXFR	Subsequent power cycles result in R_{PXFR} selection to 7.32 k Ω , which can result in longer start-up and recovery times if different R_{PXFR} from 7.32 k Ω was used in the application.	C

Table 4-9. Two-Wire Mode: Pin FMA for Device Pins Short-Circuited to VDDP

Pin Name	Pin No.	Description of Potential Failure Effect(s)	Failure Effect Class
EN	1	If EN voltage exceeds absolute maximum of VDDP, potential damage of device can occur.	A
PXFR	2	Subsequent power cycles result in R_{PXFR} selection to 7.32 k Ω , which can result in longer start-up and recovery times if different R_{PXFR} from 7.32 k Ω was used in the application.	C

5 Revision History

NOTE: Page numbers for previous revisions may differ from page numbers in the current version.

Changes from Revision * (April 2022) to Revision A (March 2023)	Page
• Added one-shot enable devices.....	5

IMPORTANT NOTICE AND DISCLAIMER

TI PROVIDES TECHNICAL AND RELIABILITY DATA (INCLUDING DATA SHEETS), DESIGN RESOURCES (INCLUDING REFERENCE DESIGNS), APPLICATION OR OTHER DESIGN ADVICE, WEB TOOLS, SAFETY INFORMATION, AND OTHER RESOURCES "AS IS" AND WITH ALL FAULTS, AND DISCLAIMS ALL WARRANTIES, EXPRESS AND IMPLIED, INCLUDING WITHOUT LIMITATION ANY IMPLIED WARRANTIES OF MERCHANTABILITY, FITNESS FOR A PARTICULAR PURPOSE OR NON-INFRINGEMENT OF THIRD PARTY INTELLECTUAL PROPERTY RIGHTS.

These resources are intended for skilled developers designing with TI products. You are solely responsible for (1) selecting the appropriate TI products for your application, (2) designing, validating and testing your application, and (3) ensuring your application meets applicable standards, and any other safety, security, regulatory or other requirements.

These resources are subject to change without notice. TI grants you permission to use these resources only for development of an application that uses the TI products described in the resource. Other reproduction and display of these resources is prohibited. No license is granted to any other TI intellectual property right or to any third party intellectual property right. TI disclaims responsibility for, and you will fully indemnify TI and its representatives against, any claims, damages, costs, losses, and liabilities arising out of your use of these resources.

TI's products are provided subject to [TI's Terms of Sale](#) or other applicable terms available either on [ti.com](https://www.ti.com) or provided in conjunction with such TI products. TI's provision of these resources does not expand or otherwise alter TI's applicable warranties or warranty disclaimers for TI products.

TI objects to and rejects any additional or different terms you may have proposed.

Mailing Address: Texas Instruments, Post Office Box 655303, Dallas, Texas 75265
Copyright © 2023, Texas Instruments Incorporated