

# TPS7E82-Q1

## Functional Safety FIT Rate, FMD and Pin FMA

---



### Table of Contents

<b>1 Overview</b> .....	2
<b>2 Functional Safety Failure In Time (FIT) Rates</b> .....	4
<b>3 Failure Mode Distribution (FMD)</b> .....	5
<b>4 Pin Failure Mode Analysis (Pin FMA)</b> .....	6
4.1 DBV (SOT-23, 5) Package.....	7
4.2 DRV (WSON, 6) Package.....	10
4.3 DGN (HVSSOP, 8) Package.....	13
<b>5 Revision History</b> .....	14

### Trademarks

All trademarks are the property of their respective owners.

## 1 Overview

This document contains information for TPS7E82-Q1 (DBV (SOT-23, 5), DRV (WSON, 6), and DGN (HVSSOP, 8) packages) to aid in a functional safety system design. Information provided are:

- Functional safety failure in time (FIT) rates of the semiconductor component estimated by the application of industry reliability standards
- Component failure modes and distribution (FMD) based on the primary function of the device
- Pin failure mode analysis (pin FMA)

Figure 1-1 shows the device functional block diagram for reference.

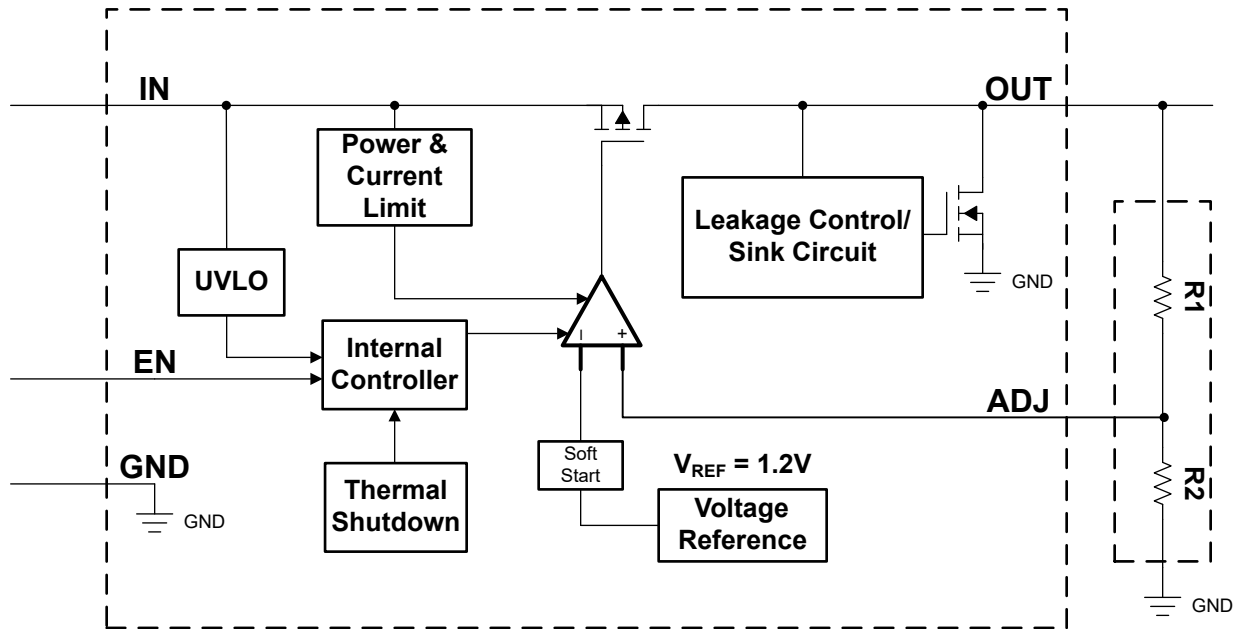

Figure 1-1. Functional Block Diagram (Adjustable Version)

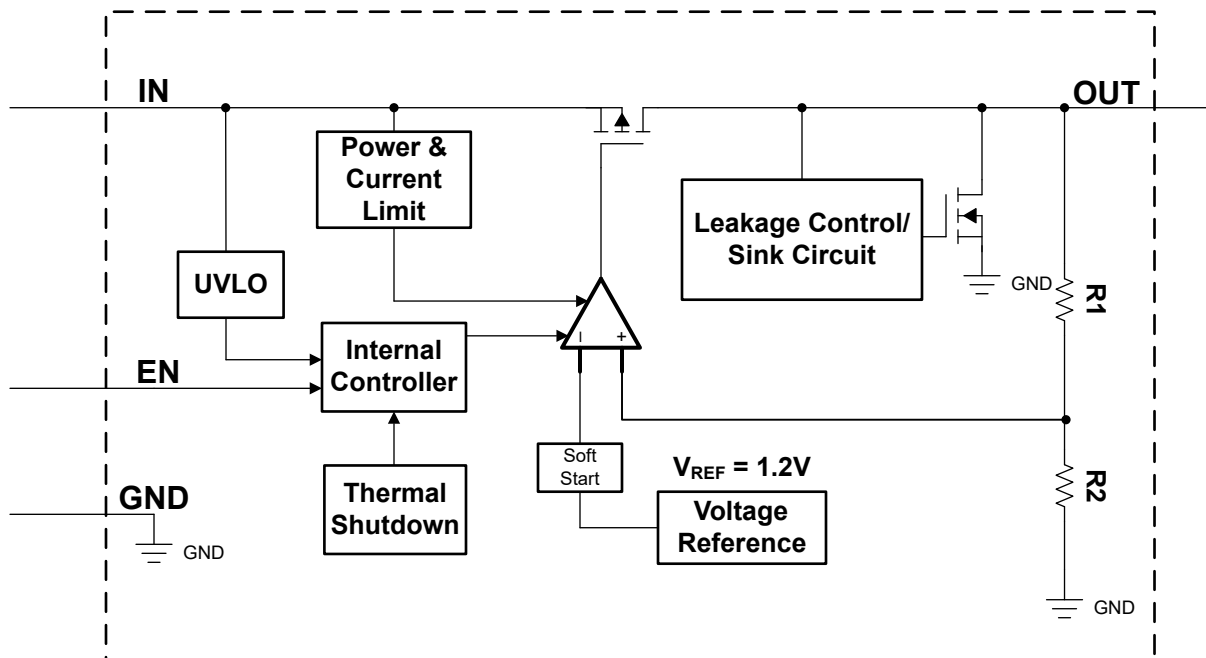

Figure 1-2. Functional Block Diagram (Fixed Version)

TPS7E82-Q1 was developed using a quality-managed development process, but was not developed in accordance with the IEC 61508 or ISO 26262 standards.

## 2 Functional Safety Failure In Time (FIT) Rates

This section provides functional safety failure in time (FIT) rates for the TPS7E82-Q1 based on two different industry-wide used reliability standards:

- [Table 2-1](#) provides FIT rates based on IEC TR 62380 / ISO 26262 part 11
- [Table 2-2](#) provides FIT rates based on the Siemens Norm SN 29500-2

**Table 2-1. Component Failure Rates per IEC TR 62380 / ISO 26262 Part 11**

FIT IEC TR 62380 / ISO 26262	FIT (Failures Per 10 <sup>9</sup> Hours)		
	Package	DBV (SOT-23, 5)	DRV (WSON, 6)
Total component FIT rate	14	12	18
Die FIT rate	11	10	10
Package FIT rate	3	2	8

The failure rate and mission profile information in [Table 2-1](#) comes from the reliability data handbook IEC TR 62380 / ISO 26262 part 11:

- Mission profile: Motor control from table 11 or figure 16
- Power dissipation: 300mW
- Climate type: World-wide table 8 or figure 13
- Package factor ( $\lambda_3$ ): Table 17b or figure 15
- Substrate material: FR4
- EOS FIT rate assumed: 0 FIT

**Table 2-2. Component Failure Rates per Siemens Norm SN 29500-2**

Table	Category	Reference FIT Rate	Reference Virtual T <sub>J</sub>
4	Power amplifier and regulator $\leq$ 1Watt – (LDO)	40 FIT	70°C

The reference FIT rate and reference virtual T<sub>J</sub> (junction temperature) in [Table 2-2](#) come from the Siemens Norm SN 29500-2 tables 1 through 5. Failure rates under operating conditions are calculated from the reference failure rate and virtual junction temperature using conversion information in SN 29500-2 section 4.

### 3 Failure Mode Distribution (FMD)

The failure mode distribution estimation for TPS7E82-Q1 in [Table 3-1](#) comes from the combination of common failure modes listed in standards such as IEC 61508 and ISO 26262, the ratio of sub-circuit function size and complexity, and from best engineering judgment.

The failure modes listed in this section reflect random failure events and do not include failures resulting from misuse or overstress.

**Table 3-1. Die Failure Modes and Distribution**

Die Failure Modes	Failure Mode Distribution (%)
No output	45
Output high (following input)	15
Output not in specification	35
Short circuit on any two pins	5

## 4 Pin Failure Mode Analysis (Pin FMA)

This section provides a failure mode analysis (FMA) for the pins of the TPS7E82-Q1 (DBV (SOT-23, 5), DRV (WSON, 6), and DGN (HVSSOP, 8) packages). The failure modes covered in this document include the typical pin-by-pin failure scenarios:

- DBV and A-Version DBV:
  - Pin short-circuited to ground (see [Table 4-2](#) and [Table 4-3](#))
  - Pin open-circuited (see [Table 4-4](#) and [Table 4-5](#))
  - Pin short-circuited to an adjacent pin (see [Table 4-6](#) and [Table 4-7](#))
  - Pin short-circuited to  $V_{BAT}$  (see [Table 4-8](#) and [Table 4-9](#))
- DRV and A-Version DRV:
  - Pin short-circuited to ground (see [Table 4-10](#) and [Table 4-11](#))
  - Pin open-circuited (see [Table 4-12](#) and [Table 4-13](#))
  - Pin short-circuited to an adjacent pin (see [Table 4-14](#) and [Table 4-15](#))
  - Pin short-circuited to  $V_{BAT}$  (see [Table 4-16](#) and [Table 4-17](#))
- DGN:
  - Pin short-circuited to ground (see [Table 4-18](#))
  - Pin open-circuited (see [Table 4-19](#))
  - Pin short-circuited to an adjacent pin (see [Table 4-20](#))
  - Pin short-circuited to  $V_{BAT}$  (see [Table 4-21](#))

[Table 4-2](#) through [Table 4-21](#) also indicate how these pin conditions can affect the device as per the failure effects classification in [Table 4-1](#).

**Table 4-1. TI Classification of Failure Effects**

Class	Failure Effects
A	Potential device damage that affects functionality.
B	No device damage, but loss of functionality.
C	No device damage, but performance degradation.
D	No device damage, no impact to functionality or performance.

### 4.1 DBV (SOT-23, 5) Package

Figure 4-1 and Figure 4-2 show the TPS7E82-Q1 pin diagrams for the DBV (SOT-23, 5) package. For a detailed description of the device pins please refer to the *Pin Configuration and Functions* section in the TPS7E82-Q1 datasheet.

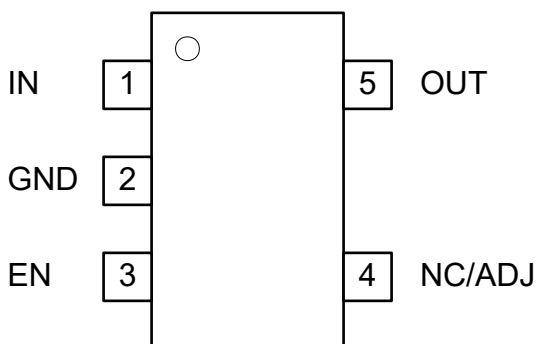

Figure 4-1. Pin Diagram (DBV Package, (Fixed/ADJ), 5-Pin SOT-23, Top View)

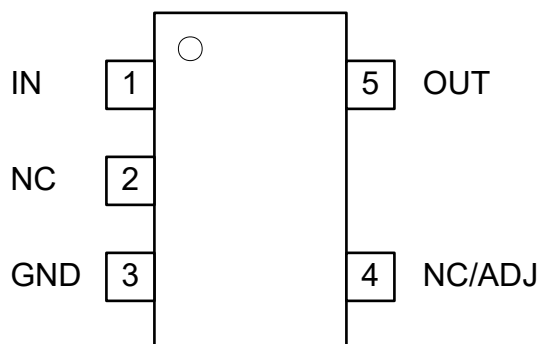

Figure 4-2. Pin Diagram (DBV Package, A-version (Fixed/ADJ), 5-Pin SOT-23, Top View)

Table 4-2. DBV Pin FMA for Device Pins Short-Circuited to Ground

Pin Name	Pin No.	Description of Potential Failure Effects	Failure Effect Class
IN	1	There is no power supplied to the device; resulting in no output voltage.	B
GND	2	There is no effect on the device. The device operates as normal.	D
EN	3	The device is stuck in shutdown mode; resulting in no output voltage.	B
NC/ADJ	4	Fixed output: There is no effect on the device. The device operates as normal.	D
		Adjustable output: The device operates in dropout mode. $V_{OUT}$ follows $V_{IN}$ and equals $V_{IN} - V_{DO}$ .	B
OUT	5	Regulation is not possible. The device operates at current limit. Depending on the power dissipation, the device cycles in and out of thermal shutdown.	B

Table 4-3. A-Version DBV Pin FMA for Device Pins Short-Circuited to Ground

Pin Name	Pin No.	Description of Potential Failure Effects	Failure Effect Class
IN	1	There is no power supplied to the device; resulting in no output voltage.	B
NC	2	There is no effect on the device. The device operates as normal.	D
GND	3	There is no effect on the device. The device operates as normal.	D
NC/ADJ	4	Fixed output: There is no effect on the device. The device operates as normal.	D
		Adjustable output: The device operates in dropout mode. $V_{OUT}$ follows $V_{IN}$ and equals $V_{IN} - V_{DO}$ .	B
OUT	5	Regulation is not possible. The device operates at current limit. Depending on the power dissipation, the device cycles in and out of thermal shutdown.	B

Table 4-4. DBV Pin FMA for Device Pins Open-Circuited

Pin Name	Pin No.	Description of Potential Failure Effects	Failure Effect Class
IN	1	There is no power supplied to the device; resulting in no output voltage.	B
GND	2	The current loop is broken. The device is not operational and does not regulate.	B
EN	3	The device has an internal pullup, and therefore, remains enabled. The device operates as normal unless the user attempts to disable the device.	D
			B
NC/ADJ	4	Fixed output: There is no effect on the device. The device operates as normal.	D
		Adjustable output: The input of the error amplifier is not connected, leaving $V_{OUT}$ in an indeterminate state.	B

**Table 4-4. DBV Pin FMA for Device Pins Open-Circuited (continued)**

Pin Name	Pin No.	Description of Potential Failure Effects	Failure Effect Class
OUT	5	The device does not provide a regulated rail and is disconnected from the load.	B

**Table 4-5. A-Version DBV Pin FMA for Device Pins Open-Circuited**

Pin Name	Pin No.	Description of Potential Failure Effects	Failure Effect Class
IN	1	There is no power supplied to the device; resulting in no output voltage.	B
NC	2	There is no effect on the device. The device operates as normal.	D
GND	3	The current loop is broken. The device is not operational and does not regulate.	B
NC/ADJ	4	Fixed output: There is no effect on the device. The device operates as normal.	D
		Adjustable output: The input of the error amplifier is not connected, leaving $V_{OUT}$ in an indeterminate state.	B
OUT	5	The device does not provide a regulated rail and is disconnected from the load.	B

**Table 4-6. DBV Pin FMA for Device Pins Short-Circuited to Adjacent Pin**

Pin Name	Pin No.	Shorted to	Pin No.	Description of Potential Failure Effects	Failure Effect Class
IN	1	GND	2	There is no power supplied to the device; resulting in no output voltage.	B
GND	2	EN	3	The device remains disabled. No output voltage is provided.	B
NC/ADJ	4	OUT	5	Fixed output: There is no effect on the device. The device operates as normal.	D
				Adjustable output: The feedback network is bypassed and the device operates in unity gain configuration. $V_{OUT} = \text{Internal Bandgap } V_{REF}$ .	B

**Table 4-7. A-Version DBV Pin FMA for Device Pins Short-Circuited to Adjacent Pin**

Pin Name	Pin No.	Shorted to	Pin No.	Description of Potential Failure Effects	Failure Effect Class
IN	1	NC	2	There is no effect on the device. The device operates as normal.	D
NC	2	GND	3	There is no effect on the device. The device operates as normal.	D
NC/ADJ	4	OUT	5	Fixed output: There is no effect on the device. The device operates as normal.	D
				Adjustable output: The feedback network is bypassed and the device operates in unity gain configuration. $V_{OUT} = \text{Internal Bandgap } V_{REF}$ .	B

**Table 4-8. DBV Pin FMA for Device Pins Short-Circuited to VBAT**

Pin Name	Pin No.	Description of Potential Failure Effects	Failure Effect Class
IN	1	The device operates as normal if already operating off-battery. If operating post-regulator, there potentially is increased power dissipation across the device and this potentially results in thermal shutdown.	D
			B
GND	2	At a system level, this results in a flow of large currents and possible collapse of the input voltage to the LDO. In this type of scenario, there is no LDO output voltage.	B
EN	3	The device remains enabled and survives the fault condition. The device operates as normal unless the user attempts to disable the device.	D
			B
NC/ADJ	4	Fixed output: There is no effect on the device. The device operates as normal.	D
		Adjustable output: This violates the absolute maximum rating of the ADJ pin and damages the device.	A
OUT	5	If operating off-battery, the device survives this fault condition but does not provide a regulated rail. If operating post-regulator, this results in a flow of reverse current and damages the device.	B
			A

**Table 4-9. A-Version DBV Pin FMA for Device Pins Short-Circuited to VBAT**

Pin Name	Pin No.	Description of Potential Failure Effects	Failure Effect Class
IN	1	The device operates as normal if already operating off-battery. If operating post-regulator, there potentially is increased power dissipation across the device and this potentially results in thermal shutdown.	D
			B
NC	2	There is no effect on the device. The device operates as normal.	D
GND	3	At a system level, this results in a flow of large currents and possible collapse of the input voltage to the LDO. In this type of scenario, there is no LDO output voltage.	B
NC/ADJ	4	Fixed output: There is no effect on the device. The device operates as normal.	D
		Adjustable output: This violates the absolute maximum rating of the ADJ pin and damages the device.	A
OUT	5	If operating off-battery, the device survives this fault condition but does not provide a regulated rail. If operating post-regulator, this results in a flow of reverse current and damages the device.	B
			A

## 4.2 DRV (WSO<sub>N</sub>, 6) Package

Figure 4-3 and Figure 4-4 show the TPS7E82-Q1 pin diagrams for the DRV (WSO<sub>N</sub>, 6) package. For a detailed description of the device pins please refer to the *Pin Configuration and Functions* section in the TPS7E82-Q1 datasheet.



**Figure 4-3. Pin Diagram (DRV Package (Fixed/ADJ), 6-Pin WSO<sub>N</sub>, Top View)**      **Figure 4-4. Pin Diagram (DRV Package, A-version (Fixed/ADJ), 6-Pin WSO<sub>N</sub>, Top View)**

**Table 4-10. DRV Pin FMA for Device Pins Short-Circuited to Ground**

Pin Name	Pin No.	Description of Potential Failure Effects	Failure Effect Class
IN	1	There is no power supplied to the device; resulting in no output voltage.	B
EN	2	The device is stuck in shutdown mode; resulting in no output voltage.	B
GND	3	There is no effect on the device. The device operates as normal.	D
NC/ADJ	4	Fixed output: There is no effect on the device. The device operates as normal.	D
		Adjustable output: The device operates in dropout mode. $V_{OUT}$ follows $V_{IN}$ and equals $V_{IN} - V_{DO}$ .	B
NC	5	There is no effect on the device. The device operates as normal.	D
OUT	6	The device is not operational with the output being pulled to GND. Current limit is triggered, and the device potentially repeats entering and exiting thermal shutdown depending on power dissipation.	B

**Table 4-11. A-Version DRV Pin FMA for Device Pins Short-Circuited to Ground**

Pin Name	Pin No.	Description of Potential Failure Effects	Failure Effect Class
OUT	1	The device is not operational with the output being pulled to GND. Current limit is triggered, and the device potentially repeats entering and exiting thermal shutdown depending on power dissipation.	B
NC/ADJ	2	Fixed output: There is no effect on the device. The device operates as normal.	D
		Adjustable Output: The device operates in dropout mode. $V_{OUT}$ follows $V_{IN}$ and equals $V_{IN} - V_{DO}$ .	B
GND	3	There is no effect on the device. The device operates as normal.	D
EN	4	The device is stuck in shutdown mode; resulting in no output voltage.	B
NC	5	There is no effect on the device. The device operates as normal.	D
IN	6	There is no power supplied to the device; resulting in no output voltage.	B

**Table 4-12. DRV Pin FMA for Device Pins Open-Circuited**

Pin Name	Pin No.	Description of Potential Failure Effects	Failure Effect Class
IN	1	There is no power supplied to the device; resulting in no output voltage.	B
EN	2	The device has an internal pullup, and therefore, remains enabled. The device operates as normal unless the user attempts to disable the device.	D B
GND	3	The current loop is broken. The device is not operational and does not regulate.	B
NC/ADJ	4	Fixed output: There is no effect on the device. The device operates as normal.	D
		Adjustable output: The input of the error amplifier is not connected, leaving $V_{OUT}$ in an indeterminate state.	B
NC	5	There is no effect on the device. The device operates as normal.	D

**Table 4-12. DRV Pin FMA for Device Pins Open-Circuited (continued)**

Pin Name	Pin No.	Description of Potential Failure Effects	Failure Effect Class
OUT	6	The device does not provide a regulated rail and is disconnected from the load.	B

**Table 4-13. A-Version DRV Pin FMA for Device Pins Open-Circuited**

Pin Name	Pin No.	Description of Potential Failure Effects	Failure Effect Class
OUT	1	The device does not provide a regulated rail and is disconnected from the load.	B
NC/ADJ	2	Fixed output: There is no effect on the device. The device operates as normal.	D
		Adjustable output: The error amplifier input is not connected, leaving $V_{OUT}$ in an indeterminate state.	B
GND	3	The current loop is broken. The device is not operational and does not regulate.	B
EN	4	The device has an internal pullup, and therefore, remains enabled. The device operates as normal unless the user attempts to disable the device.	D
			B
NC	5	There is no effect on the device. The device operates as normal.	D
IN	6	There is no power supplied to the device; resulting in no output voltage.	B

**Table 4-14. DRV Pin FMA for Device Pins Short-Circuited to Adjacent Pin**

Pin Name	Pin No.	Shorted to	Pin No.	Description of Potential Failure Effects	Failure Effect Class
IN	1	EN	2	The EN pin is pulled to the IN supply. Shutdown mode is not possible. The device is powered on as long as the input supply is present.	D
					B
EN	2	GND	3	The device is stuck in shutdown mode; resulting in no output voltage.	B
NC/ADJ	4	NC	5	Fixed output: There is no effect on the device. The device operates as normal.	D
				Adjustable output: There is no effect on the device. The device operates as normal.	D
NC	5	OUT	6	There is no effect on the device. The device operates as normal.	D

**Table 4-15. A-Version DRV Pin FMA for Device Pins Short-Circuited to Adjacent Pin**

Pin Name	Pin No.	Shorted to	Pin No.	Description of Potential Failure Effects	Failure Effect Class
OUT	1	NC/ADJ	2	Fixed output: There is no effect on the device. The device operates as normal.	D
				Adjustable output: The feedback network is bypassed and the device operates in unity gain configuration. $V_{OUT} = \text{Internal Bandgap } V_{REF}$ .	B
NC/ADJ	2	GND	3	Fixed output: There is no effect on the device. The device operates as normal.	D
				Adjustable output: The device operates in dropout mode. $V_{OUT}$ follows $V_{IN}$ and equals $V_{IN} - V_{DO}$ .	B
EN	4	NC	5	There is no effect on the device. The device operates as normal.	D
NC	5	IN	6	There is no effect on the device. The device operates as normal.	D

**Table 4-16. DRV Pin FMA for Device Pins Short-Circuited to  $V_{BAT}$**

Pin Name	Pin No.	Description of Potential Failure Effects	Failure Effect Class
IN	1	The device operates as normal if already operating off-battery. If operating post-regulator, there potentially is increased power dissipation across the device and this potentially results in thermal shutdown.	D
			B

**Table 4-16. DRV Pin FMA for Device Pins Short-Circuited to V<sub>BAT</sub> (continued)**

Pin Name	Pin No.	Description of Potential Failure Effects	Failure Effect Class
EN	2	The device remains enabled and survives the fault condition. The device operates as normal unless the user attempts to disable the device.	D
			B
GND	3	At a system level, this results in a flow of large currents and possible collapse of the input voltage to the LDO. In this type of scenario, there is no LDO output voltage.	B
NC/ADJ	4	Fixed output: There is no effect on the device. The device operates as normal.	D
		Adjustable output: This violates the absolute maximum rating of the ADJ pin and damages the device.	A
NC	5	There is no effect on the device. The device operates as normal.	D
OUT	6	If operating off-battery, the device survives this fault condition but does not provide a regulated rail. If operating post-regulator, this results in a flow of reverse current and damages the device.	B
			A

**Table 4-17. A-Version DRV Pin FMA for Device Pins Short-Circuited to V<sub>BAT</sub>**

Pin Name	Pin No.	Description of Potential Failure Effects	Failure Effect Class
OUT	1	If operating off-battery, the device survives this fault condition but does not provide a regulated rail. If operating post-regulator, this results in a flow of reverse current and damages in device.	B
			A
NC/ADJ	2	Fixed output: There is no effect on the device. The device operates as normal.	D
		Adjustable output: This violates the absolute maximum rating of the ADJ pin and damages the device.	A
GND	3	At a system level, this results in a flow of large currents and possible collapse of the input voltage to the LDO. In this type of scenario, there is no LDO output voltage.	B
EN	4	The device remains enabled and survives the fault condition. The device operates as normal unless the user attempts to disable the device.	D
			B
NC	5	There is no effect on the device. The device operates as normal.	D
IN	6	The device operates as normal if already operating off-battery. If operating post-regulator, there potentially is increased power dissipation across the device and this potentially results in thermal shutdown.	D
			B

### 4.3 DGN (HVSSOP, 8) Package

Figure 4-3 shows the TPS7E82-Q1 pin diagram for the DGN (HVSSOP, 8) package. For a detailed description of the device pins please refer to the *Pin Configuration and Functions* section in the TPS7E82-Q1 datasheet.

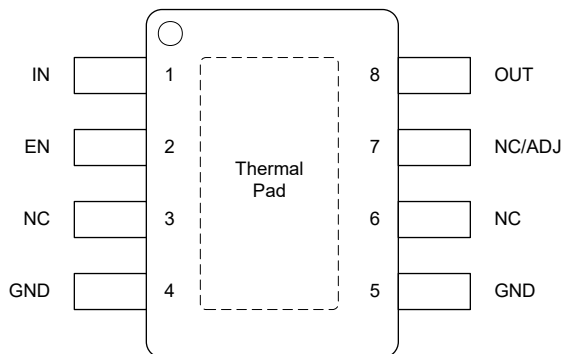

Figure 4-5. Pin Diagram (DGN (HVSSOP, 8) Package)

Table 4-18. Pin FMA for Device Pins Short-Circuited to Ground

Pin Name	Pin No.	Description of Potential Failure Effects	Failure Effect Class
IN	1	There is no power supplied to the device; resulting in no output voltage.	B
EN	2	The device is stuck in shutdown mode; resulting in no output voltage.	B
NC	3	There is no effect on the device. The device operates as normal.	D
GND	4	There is no effect on the device. The device operates as normal.	D
GND	5	There is no effect on the device. The device operates as normal.	D
NC	6	There is no effect on the device. The device operates as normal.	D
NC/ADJ	7	Fixed output: There is no effect on the device. The device operates as normal.	D
		Adjustable output: The device operates in dropout mode. $V_{OUT}$ follows $V_{IN}$ and equals $V_{IN} - V_{DO}$ .	B
OUT	8	The device is not operational with the output being pulled to GND. Current limit is triggered, and the device potentially repeats entering and exiting thermal shutdown depending on power dissipation.	B

Table 4-19. Pin FMA for Device Pins Open-Circuited

Pin Name	Pin No.	Description of Potential Failure Effects	Failure Effect Class
IN	1	There is no power supplied to the device; resulting in no output voltage.	B
EN	2	The device has an internal pullup, and therefore, remains enabled. The device operates as normal unless the user attempts to disable the device.	D
			B
NC	3	There is no effect on the device. The device operates as normal.	D
GND	4	There is no effect on the device. The device operates as normal since the device has an additional ground pin.	D
GND	5	There is no effect on the device. The device operates as normal since the device has an additional ground pin.	D
NC	6	There is no effect on the device. The device operates as normal.	D
NC/ADJ	7	Fixed output: There is no effect on the device. The device operates as normal.	D
		Adjustable output: The input of the error amplifier is not connected, leaving $V_{OUT}$ in an indeterminate state.	B
OUT	8	The device does not provide a regulated rail and is disconnected from the load.	B

**Table 4-20. Pin FMA for Device Pins Short-Circuited to Adjacent Pin**

Pin Name	Pin No.	Shorted to	Pin No.	Description of Potential Failure Effects	Failure Effect Class
IN	1	EN	2	The EN pin is pulled to the IN supply. Shutdown mode is not possible. The device is powered on as long as the input supply is present.	D
					B
EN	2	NC	3	There is no effect on the device. The device operates as normal.	D
NC	3	GND	4	There is no effect on the device. The device operates as normal.	D
GND	4	NC	5	There is no effect on the device. The device operates as normal.	D
NC		NC/ADJ		Fixed output: There is no effect on the device. The device operates as normal.	D
				Adjustable output: There is no effect on the device. The device operates as normal.	D
NC/ADJ		OUT		Fixed output: There is no effect on the device. The device operates as normal.	D
				Adjustable output: The feedback network is bypassed and the device operates in unity gain configuration. $V_{OUT} = \text{Internal Bandgap } V_{REF}$ .	B

**Table 4-21. Pin FMA for Device Pins Short-Circuited to  $V_{BAT}$** 

Pin Name	Pin No.	Description of Potential Failure Effects	Failure Effect Class
IN	1	The device operates as normal if already operating off-battery. If operating post-regulator, there is potentially increased power dissipation across the device and this potentially results in thermal shutdown.	D
			B
EN	2	The device remains enabled and survives the fault condition. The device operates as normal unless the user attempts to disable the device.	D
			B
NC	3	There is no effect on the device. The device operates as normal.	D
GND	4	At a system level, this results in a flow of large currents and possible collapse of the input voltage to the LDO. In this type of scenario, there is no LDO output voltage.	B
GND	5	At a system level, this results in a flow of large currents and possible collapse of the input voltage to the LDO. In this type of scenario, there is no LDO output voltage.	B
NC	6	There is no effect on the device. The device operates as normal.	D
NC/ADJ	7	Fixed output: There is no effect on the device. The device operates as normal.	D
		Adjustable output: This violates the absolute maximum rating of the ADJ pin and damages the device.	A
OUT	8	If operating off-battery, the device survives this fault condition but does not provide a regulated rail. If operating post-regulator, this results in a flow of reverse current and damages the device.	B
			A

## 5 Revision History

NOTE: Page numbers for previous revisions may differ from page numbers in the current version.

DATE	REVISION	NOTES
April 2026	*	Initial Release

## IMPORTANT NOTICE AND DISCLAIMER

TI PROVIDES TECHNICAL AND RELIABILITY DATA (INCLUDING DATASHEETS), DESIGN RESOURCES (INCLUDING REFERENCE DESIGNS), APPLICATION OR OTHER DESIGN ADVICE, WEB TOOLS, SAFETY INFORMATION, AND OTHER RESOURCES "AS IS" AND WITH ALL FAULTS, AND DISCLAIMS ALL WARRANTIES, EXPRESS AND IMPLIED, INCLUDING WITHOUT LIMITATION ANY IMPLIED WARRANTIES OF MERCHANTABILITY, FITNESS FOR A PARTICULAR PURPOSE OR NON-INFRINGEMENT OF THIRD PARTY INTELLECTUAL PROPERTY RIGHTS.

These resources are intended for skilled developers designing with TI products. You are solely responsible for (1) selecting the appropriate TI products for your application, (2) designing, validating and testing your application, and (3) ensuring your application meets applicable standards, and any other safety, security, regulatory or other requirements.

These resources are subject to change without notice. TI grants you permission to use these resources only for development of an application that uses the TI products described in the resource. Other reproduction and display of these resources is prohibited. No license is granted to any other TI intellectual property right or to any third party intellectual property right. TI disclaims responsibility for, and you fully indemnify TI and its representatives against any claims, damages, costs, losses, and liabilities arising out of your use of these resources.

TI's products are provided subject to [TI's Terms of Sale](#), [TI's General Quality Guidelines](#), or other applicable terms available either on [ti.com](http://ti.com) or provided in conjunction with such TI products. TI's provision of these resources does not expand or otherwise alter TI's applicable warranties or warranty disclaimers for TI products. Unless TI explicitly designates a product as custom or customer-specified, TI products are standard, catalog, general purpose devices.

TI objects to and rejects any additional or different terms you may propose.

Copyright © 2026, Texas Instruments Incorporated

Last updated 10/2025