

LM5137F-Q1 12V, 20A Single-Output Evaluation Module



Description

The LM5137F-Q1-EVM12V evaluation module (EVM) is designed to showcase the LM5137F-Q1 synchronous, buck controller, which is intended for [functional safety](#) applications up to ASIL D. The EVM operates as a two-phase interleaved design over an input voltage range of 36V to 72V to deliver a 12V regulated output at up to 20A.

Get Started

1. Order the [LM5137F-Q1-EVM12V](#).
2. Refer to the [LM5137F-Q1](#) and [LM5137-Q1](#) product folders.
3. Review the Altium [PCB layout](#) source files.
4. Use the LM5137F-Q1 [quickstart calculator](#) to assist with component selection in your design.
5. Simulate the design using [PSPICE](#) or [SIMPLIS](#).

Features

- Maximum input voltage of 72V
 - V_{IN} UVLO thresholds set at 42V (on), 36V (off)
- Tightly regulated output voltage of 12V rated at 20A with 1mV load and line regulation
- High efficiency: 95.5% at 48V_{IN}, 20A_{OUT}
 - VCC bias power derived from the 12V output
- Switching frequency of 400kHz synchronizable $\pm 20\%$ with an external clock signal
- Input π -stage EMI filter helps meet CISPR 25

- Spread spectrum (DRSS) option for lower electromagnetic interference (EMI)
- Electrolytic capacitor for parallel damping
- Peak current-mode control architecture provides fast line and load transient response
 - Integrated slope compensation
 - Forced PWM (FPWM) or pulsed frequency modulation (PFM) mode operation
- Integrated power MOSFET gate drivers
 - 3A sink, 2A source gate drive current capability
 - Adaptive deadtime control reduces power dissipation and MOSFET temperature rise
- Integrated protection features for robust design
 - Overcurrent protection (OCP) with shunt or inductor DCR current sensing
 - Monotonic prebias output voltage start-up
 - User-adjustable soft-start time set to 4.5ms
 - PG and $\overline{\text{FAULT}}$ outputs for each channel
 - Current monitor output (IMON1, IMON2)
- Fully assembled, tested and proven PCB layout with 3.3" \times 2.9" (84mm \times 74mm) total footprint

Applications

- High-current [automotive electronic systems](#) using 2, 3, and 4-phase implementations
- [Advanced driver assistance systems \(ADAS\)](#) and [body electronics](#)
- [Infotainment systems](#) and [instrument clusters](#)
- [Automotive HEV/EV powertrain systems](#)

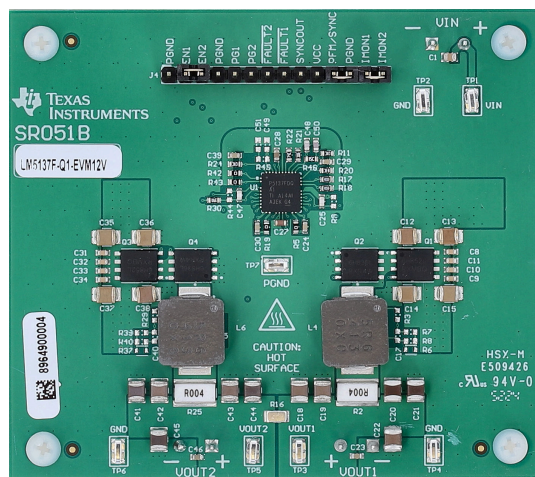

LM5137F-Q1 EVM, 84mm \times 74mm

1 Evaluation Module Overview

1.1 Introduction

The [LM5137F-Q1-EVM12V](#) evaluation module (EVM) is a two-phase, synchronous, buck DC/DC regulator that employs synchronous rectification to achieve high conversion efficiency in a small footprint. The EVM operates over a wide input voltage range of 36V to 72V, providing a regulated single output of 12V. The output voltage has better than 1% setpoint accuracy and is adjustable by modifying the feedback resistor values, permitting the user to customize the output voltage within a range of 3.3V to 20V as needed. Alternatively, as shown in [Figure 1-2](#), the EVM is configurable as a dual-output design (at 10A per output) by changing the COMP network configuration, the CNFG resistor, and removing the shorting element between the VOUT1 and VOUT2 power connectors.

Inherent protection features for robust design include input supply voltage, VCC and gate-drive UVLO; independent IMON, PG and FAULT indicator outputs for each channel; resistor-adjustable soft start; hiccup-mode overcurrent protection; and thermal shutdown with hysteresis. The selected power-train passive components, including 80V power MOSFETs, 5.6μH buck inductors, 4mΩ shunts, 4.7μF, 100V ceramic input capacitors and 22μF, 25V ceramic output capacitors – are AEC-Q200 rated and available from multiple component vendors.

The EVM design uses the [LM5137F-Q1](#) buck controller IC, which is specifically developed for [functional safety](#) applications and incorporates the following key features:

- Wide V_{IN} range up to 80V maximum
- 100% duty cycle capability
- Ultra-low shutdown (4μA) and no-load standby (15μA) quiescent currents
- Multiphase capability
- Peak current-mode control loop architecture with slope compensation
- Integrated, high-current MOSFET gate drivers with adaptive deadtime
- Optional dual-random spread spectrum (DRSS) modulation for lower EMI
- Independent current monitor (IMON), power-good (PG) and FAULT indicator outputs on each channel

1.2 Kit Contents

- A complete buck regulator EVM rated at 20A, including the LM5137F-Q1 two-phase synchronous buck controller IC
- EVM Disclaimer Read Me

1.3 Specifications

The following table lists the EVM specifications. $V_{IN} = 48V$, unless otherwise indicated.

Table 1-1. Electrical Performance Characteristics

PARAMETER	TEST CONDITIONS	MIN	TYP	MAX	UNIT
INPUT CHARACTERISTICS					
Input voltage, V_{IN}	Operating range (after turn-on)	36	48	72	V
Input UVLO turn-on threshold, V_{IN-ON}	$R_{UV1} = 100k\Omega$, $R_{UV2} = 2.43k\Omega$, $R_{UV3} = 4.99k\Omega$, EN1 jumpered to EN2 on header J4		42		V
Input UVLO turn-off threshold, V_{IN-OFF}			36		V
Input supply current, no load, FPWM, $I_{IN-NL(FPWM)-2PH}$	$I_{OUT} = 0A$, PFM/SYNC tied to GND	$V_{IN} = 36V$		58	mA
		$V_{IN} = 48V$		56	
		$V_{IN} = 72V$		51	
Input supply current, no load, FPWM, $I_{IN-NL(FPWM)-1PH}$	$I_{OUT} = 0A$, $V_{EN2} = 0V$, PFM/SYNC tied to GND	$V_{IN} = 36V$		29	mA
		$V_{IN} = 48V$		28	
		$V_{IN} = 72V$		25	
IC quiescent current in shutdown, $I_{IN-SHDN}$	$V_{EN1} = V_{EN2} = 0V$		4		μA
OUTPUT CHARACTERISTICS					
Output voltage, V_{OUT}	Fixed output setting (or adjustable output setting with 93.1k Ω and 6.65k Ω feedback divider) ⁽¹⁾	11.9	12	12.1	V
Output current, I_{OUT}	Electrical design current (EDC)			20	A
	Thermal design current (TDC) ⁽²⁾ , airflow = 100LFM ⁽³⁾			20	A
Output voltage regulation in FPWM, ΔV_{OUT}	Load regulation	$I_{OUT} = 0A$ to 20A		1	mV
	Line regulation	$V_{IN} = 36V$ to 72V		1	
Output voltage ripple, V_{OUT-AC}	$I_{OUT} = 20A$		10		mV _{RMS}
Output overcurrent protection, $I_{OUT-OCP}$	$R_{S1} = R_{S2} = 4m\Omega$		25		A
Soft-start time, t_{SS}	$R_{SS} = 20k\Omega$		4.5		ms
Hiccup time, t_{RES}	16384 clock cycles		41		ms
SYSTEM CHARACTERISTICS					
Switching frequency, F_{SW}	$R_{RT} = 57.6k\Omega$		400		kHz
Half-load efficiency, η_{HALF}	$I_{OUT} = 10A$	$V_{IN} = 36V$		96.5%	
		$V_{IN} = 48V$		95.5%	
		$V_{IN} = 60V$		94.6%	
Full-load efficiency, η_{FULL}	$I_{OUT} = 20A$	$V_{IN} = 36V$		96.2%	
		$V_{IN} = 48V$		95.5%	
		$V_{IN} = 60V$		95.0%	
LM5137F-Q1 junction temperature, T_J		-40		150	$^{\circ}C$

- (1) The default output voltage of this EVM is 12V. Efficiency and other performance metrics can change based on the operating input voltage, load current, externally-connected output capacitors and other parameters.
- (2) EDC and TDC can differ, for example when the application requires short-duration transients to a high current that does not substantially increase the operating temperatures of the power-stage components.
- (3) The recommended airflow is 100LFM when operating at full rated load of 20A.

1.3.1 Application Circuit Diagrams

Figure 1-1 shows an LM5137-Q1 synchronous buck regulator (not including the EMI filter stage). Furthermore, as shown in Figure 1-2, the user can implement a dual-output buck regulator by removing the shorting element connecting the two phases, revising the components at COMP1, COMP2, FB1, and FB2 as needed, and setting the CNFG resistor to 10kΩ.

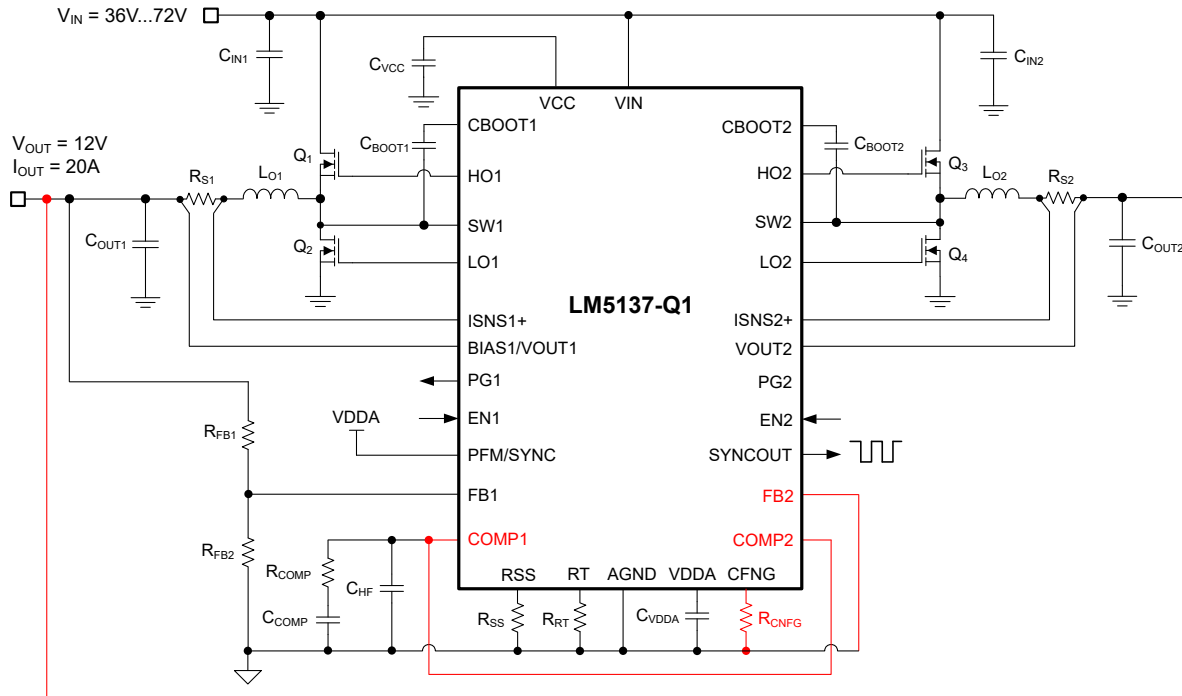

Figure 1-1. LM5137-Q1 Two-Phase, Single-Output, Synchronous Buck Regulator Simplified Schematic

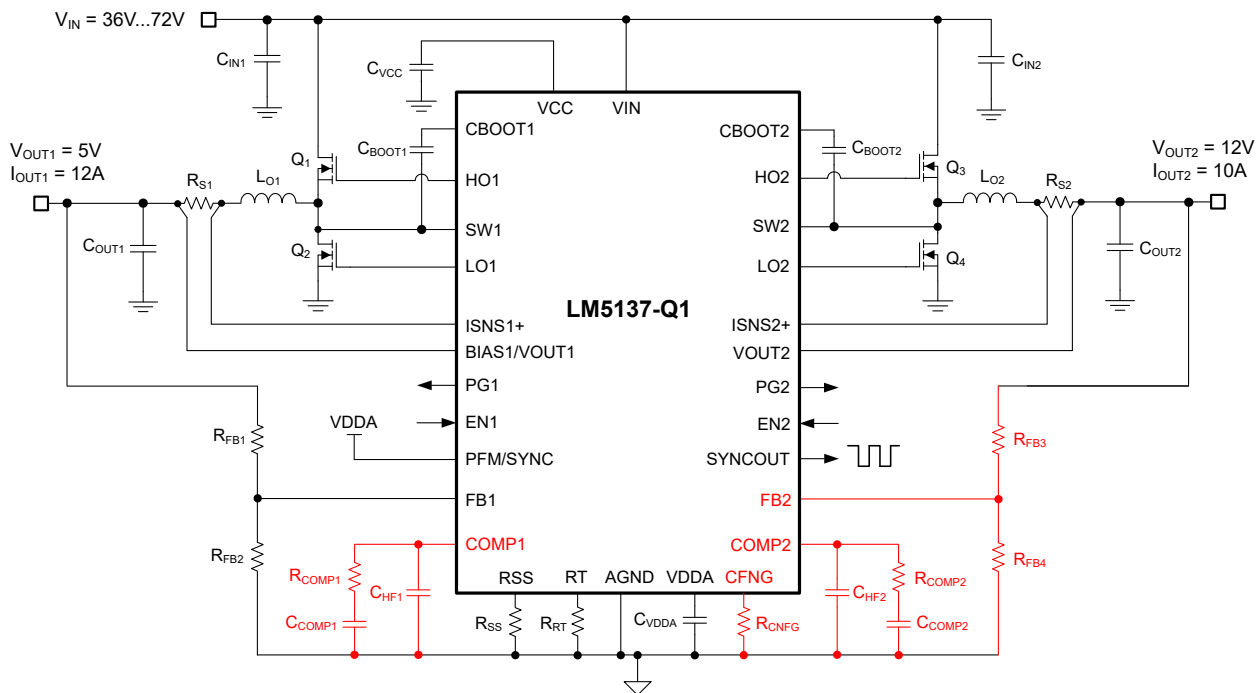

Figure 1-2. LM5137-Q1 Dual-Output, Synchronous, Buck Regulator Simplified Schematic

1.4 Device Information

With an input operating voltage as low as 3.5V and up to 100V as specified in [Table 1-2](#), the LM(2)51xx-Q1 family of automotive synchronous buck controllers from TI provides flexibility, scalability, and optimized design size for a variety of applications.

With the LM5137F-Q1 and LM25137F-Q1 controllers now available to aid in functional safety system design up to ASIL D, the controller family enables DC/DC regulator designs with high density, low EMI and increased system reliability. All controllers are rated for a maximum operating junction temperature of 150°C and have AEC-Q100 grade 1 qualification.

Table 1-2. Automotive, Synchronous, Buck DC/DC Controller Family

DC/DC Controller	Single or Dual	V _{IN} Range	Control Method	Gate Drive Voltage	Sync Output	Key Feature
LM5137-Q1	Dual	4V to 80V	Peak current mode	5V	90° phase shift	100% duty cycle
LM5137F-Q1	Dual	4V to 80V	Peak current mode	5V	90° phase shift	ASIL B or D
LM25137-Q1	Dual	4V to 42V	Peak current mode	5V	90° phase shift	100% duty cycle
LM25137F-Q1	Dual	4V to 42V	Peak current mode	5V	90° phase shift	ASIL B or D
LM5141-Q1	Single	3.8V to 65V	Peak current mode	5V	N/A	Split gate drive
LM25141-Q1	Single	3.8V to 42V	Peak current mode	5V	N/A	Split gate drive
LM5143A-Q1	Dual	3.5V to 65V	Peak current mode	5V	90° phase shift	Split gate drive
LM25143-Q1	Dual	3.5V to 42V	Peak current mode	5V	90° phase shift	Split gate drive
LM5145-Q1	Single	5.5V to 75V	Voltage mode	7.5V	180° phase shift	No shunt
LM5146-Q1	Single	5.5V to 100V	Voltage mode	7.5V	180° phase shift	100V input capability
LM5148-Q1	Single	3.5V to 80V	Peak current mode	5V	180° phase shift	DRSS
LM25148-Q1	Single	3.5V to 42V	Peak current mode	5V	180° phase shift	DRSS
LM5149-Q1	Single	3.5V to 80V	Peak current mode	5V	180° phase shift	AEF
LM25149-Q1	Single	3.5V to 42V	Peak current mode	5V	180° phase shift	AEF
LM5190-Q1	Single	5V to 80V	Peak current mode	7.5V	N/A	CC/CV
LM25190-Q1	Single	5V to 42V	Peak current mode	7.5V	N/A	CC/CV

The [LM5137-Q1](#) and [LM5137F-Q1](#), which are the TI Functional-Safety capable and compliant (ASIL B and ASIL D) versions, respectively, are available in a 36-pin VQFN package with 6mm × 6mm footprint to enable DC/DC regulator designs with high density and low component count.

Use the LM5137(F)-Q1 with [WEBENCH® Power Designer](#) to create a custom regulator design. To optimize component selection and examine predicted efficiency performance across line and load ranges, download the LM(2)5137(F)-Q1 [quickstart calculator](#).

2 Hardware

2.1 Test Setup and Procedure

2.1.1 EVM Connections

Referencing the EVM connections described in [Table 2-1](#), [Figure 2-1](#) shows the recommended test setup to evaluate the LM5137F-Q1-EVM12V. Working at an ESD-protected workstation, verify that any wrist straps, boot straps, or mats are connected and referencing the user to earth ground before handling the EVM.

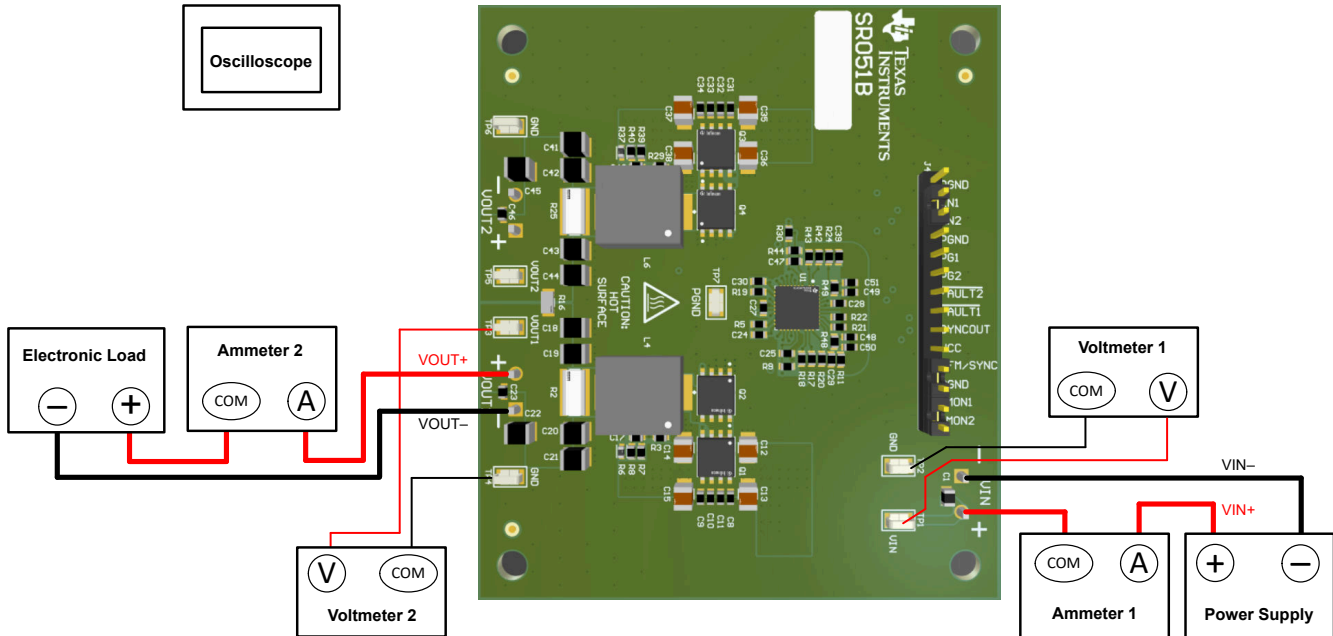

Figure 2-1. EVM Test Setup

Table 2-1. EVM Power Connections

LABEL	DESCRIPTION
VIN	Positive input voltage power and sense connection
GND	Negative input voltage power and sense connection
VOUT1	Positive output voltage power and sense connection
GND	Negative output voltage power and sense connection

Table 2-2. EVM Signal Connections

LABEL	DESCRIPTION
PGND	GND connection
EN1, EN2	ENABLE inputs – tie to GND to disable the respective phase
PG1, PG2	Power-Good outputs (only PG1 is active in two-phase mode)
FAULT1, FAULT2	FAULT outputs
SYNCOUT	Synchronization output
VCC	Bias rail connection
PFM/SYNCIN	Synchronization input
IMON1, IMON2	Current monitor outputs

Note

Refer to the [LM5137-Q1 Automotive, 4V to 80V, 100% Duty Cycle Capable, Dual-Channel Synchronous Buck Controller](#) data sheet, [quickstart calculator](#), and [WEBENCH® Power Designer](#) for additional guidance pertaining to component selection and controller operation.

2.1.2 Test Equipment

Voltage Source: Use an input voltage source capable of supplying 0V to 72V and 10A.

Multimeters:

- **Voltmeter 1:** Input voltage at VIN to GND. Set the voltmeter to an input impedance of 100M Ω .
- **Voltmeter 2:** Output voltage at VOUT to GND. Set the voltmeter to an input impedance of 100M Ω .
- **Ammeter 1:** Input current. Set ammeter to a 1-second aperture time.
- **Ammeter 2:** Output current. Set ammeter to a 1-second aperture time.

Electronic Load: The load must be an electronic constant-resistance (CR) or constant-current (CC) mode load capable of 0A to 20A at 12V. For a no-load input current measurement, disconnect the electronic load (as the load can draw a residual current).

Oscilloscope: With the scope set to 20MHz bandwidth and AC coupling, measure the output voltage ripple directly across an output capacitor with a short ground lead normally provided with the scope probe. Place the oscilloscope probe tip on the positive terminal of the output capacitor, holding the ground barrel of the probe through the ground lead to the negative terminal of the capacitor. TI does not recommend using a long-leaded ground connection, as this action can induce additional noise given a large ground loop. Adjust the oscilloscope as needed to measure other waveforms.

Safety: Always use caution when touching any circuits that can be live or energized.

2.1.3 Recommended Test Setup

2.1.3.1 Input Connections

- Prior to connecting the DC input source, set the current limit of the input supply to 0.1A maximum. Make sure the input source is initially set to 0V and connected to the VIN+ and VIN– connection points as shown in [Figure 2-1](#). TI recommends an additional input bulk capacitor to provide damping when using long input lines.
- Connect voltmeter 1 at the VIN+ and VIN– sense points to measure the input voltage.
- Connect ammeter 1 to measure the input current and set to at least 1-second aperture time.

2.1.3.2 Output Connections

- Connect an electronic load to the output power connections. Set the load to constant-resistance mode or constant-current mode at 0A before applying input voltage.
- Connect voltmeter 2 at VOUT1 and GND connections to measure the output voltage.
- Connect ammeter 2 to measure the output current.

2.1.4 Test Procedure

2.1.4.1 Line and Load Regulation, Efficiency

- Set up the EVM as described above.
- Set load to constant resistance or constant current mode and to sink 0A.
- Increase input source from 0V to 48V; use voltmeter 1 to measure the input voltage.
- Increase the current limit of the input supply to 10A.
- Using voltmeter 2 to measure the output voltage, V_{OUT} , vary the load current from 0A to 20A; V_{OUT} must remain within the load regulation specification.
- Set the load current to 10A (50% rated load) and vary the input source voltage from 36V to 72V; V_{OUT} must remain within the line regulation specification.
- Decrease the load to 0A. Decrease the input source voltage to 0V.

3 Implementation Results

3.1 Test Data and Performance Curves

Figure 3-1 through Figure 3-8 present typical performance plots and waveforms for the LM5137F-Q1-EVM12V. Because actual performance data can be affected by measurement techniques and environmental variables, these curves are presented for reference and can differ from actual field measurements.

3.1.1 Efficiency

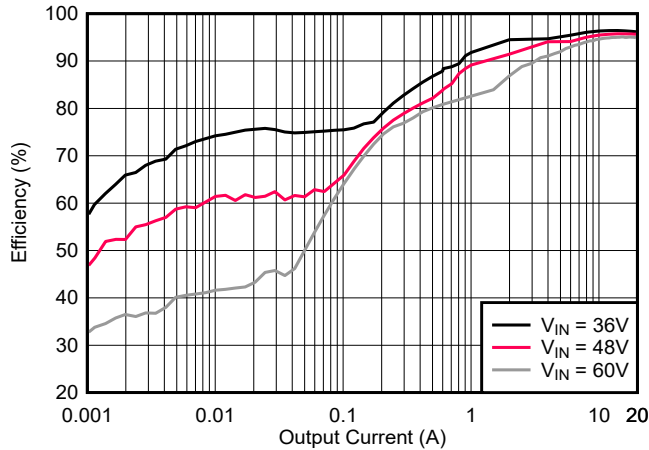

Figure 3-1. Efficiency, $V_{OUT} = 12V$, FPWM/SYNC tied low

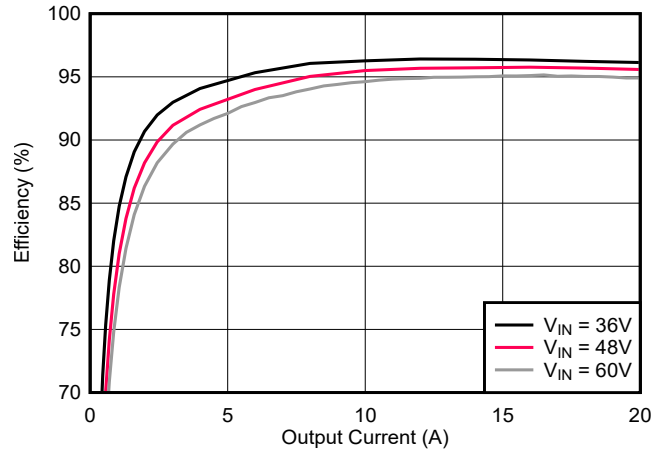

Figure 3-2. Efficiency, $V_{OUT} = 12V$, FPWM/SYNC tied high

3.1.2 Operating Waveforms

3.1.2.1 Load Transient Response

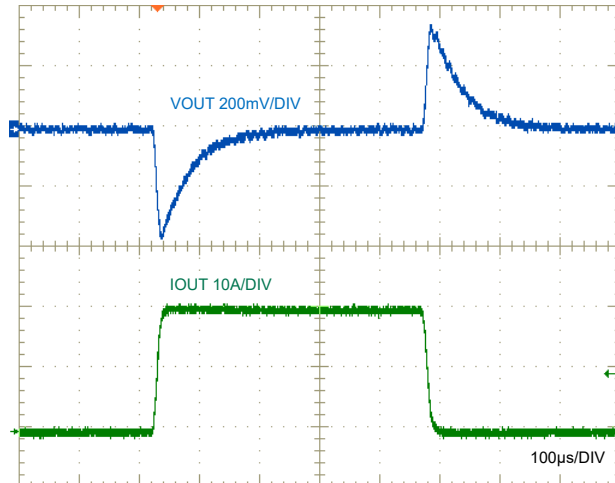

Figure 3-3. Load Transient Response, $V_{IN} = 48V$, FPWM, 0A to 20A at 1A/ μ s

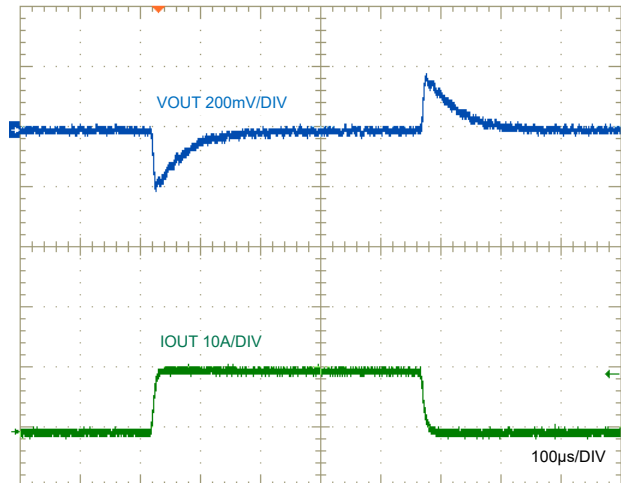

Figure 3-4. Load Transient Response, $V_{IN} = 48V$, FPWM, 0A to 10A at 1A/ μ s

3.1.2.2 Start-Up and Shutdown With VIN

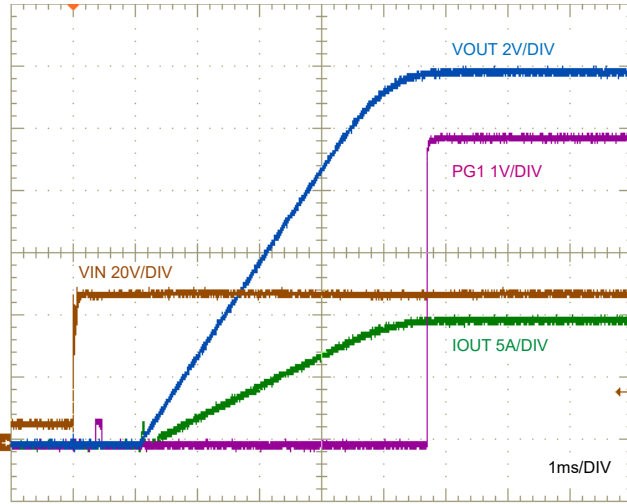

Figure 3-5. Start-Up Characteristic, V_{IN} Stepped to 48V, $I_{OUT} = 10A$ Resistive

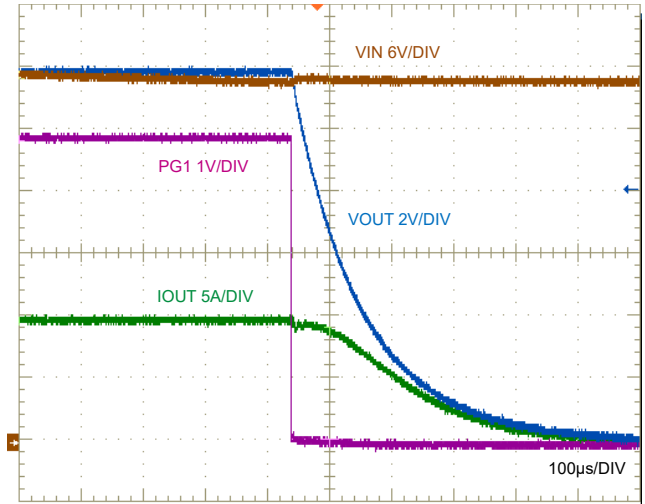

Figure 3-6. Shutdown Characteristic, $V_{IN} = 48V$, $I_{OUT} = 10A$ Resistive

3.1.2.3 Start-Up and Shutdown With ENABLE ON and OFF

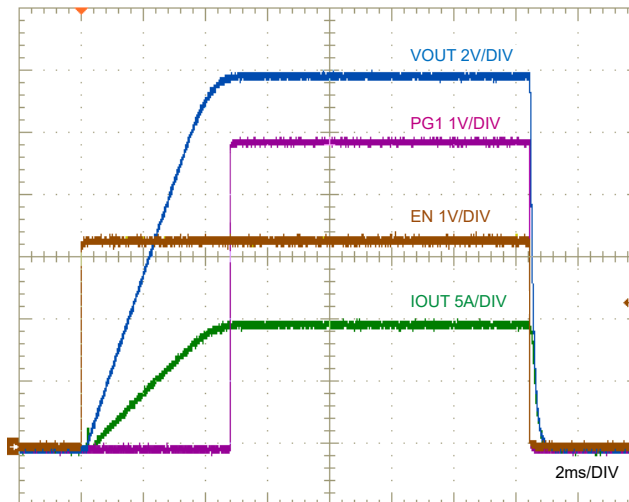

Figure 3-7. ENABLE ON and OFF, $V_{IN} = 48V$, $I_{OUT} = 10A$ Resistive

3.1.2.4 Switching Operation

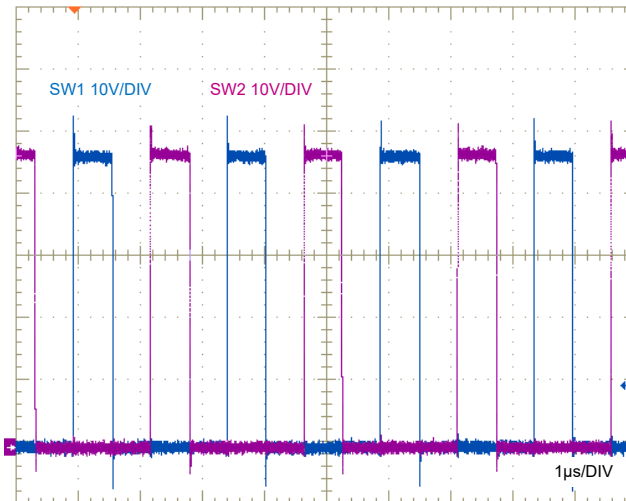

Figure 3-8. Switch-node Voltages, $V_{IN} = 48V$, $I_{OUT} = 20A$

4 Hardware Design Files

4.1 Schematic

The following image provides the EVM schematic (using the ASIL D version of the LM5137F-Q1).

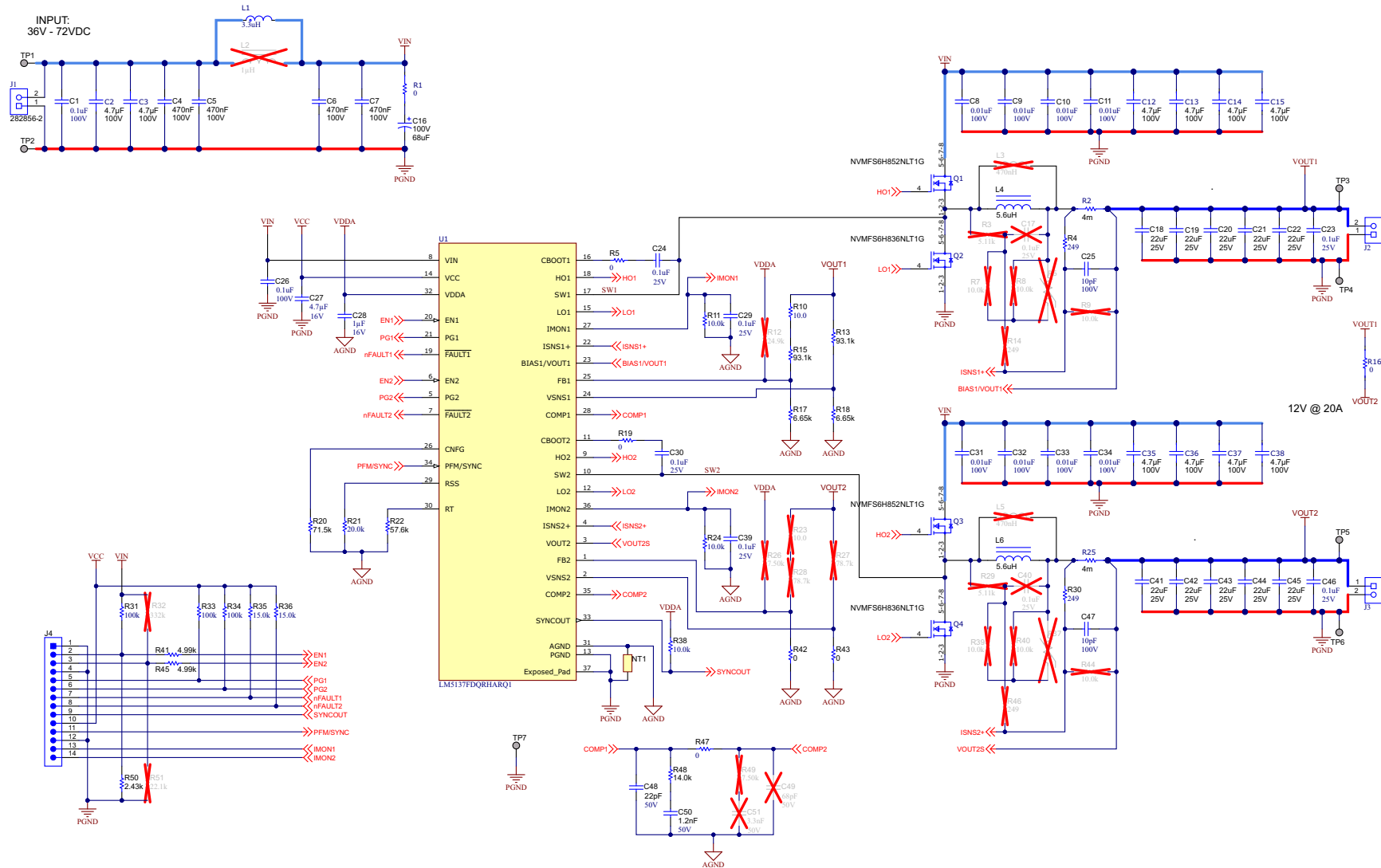

Figure 4-1. EVM Schematic

4.2 PCB Layout

Figure 4-2 through Figure 4-9 show the design of the EVM using a 6-layer PCB with 2oz copper weight (2.8mils or 70µm copper thickness). The EVM is essentially a single-sided design except for the EMI filter and some optional 0603 components located on the bottom side.

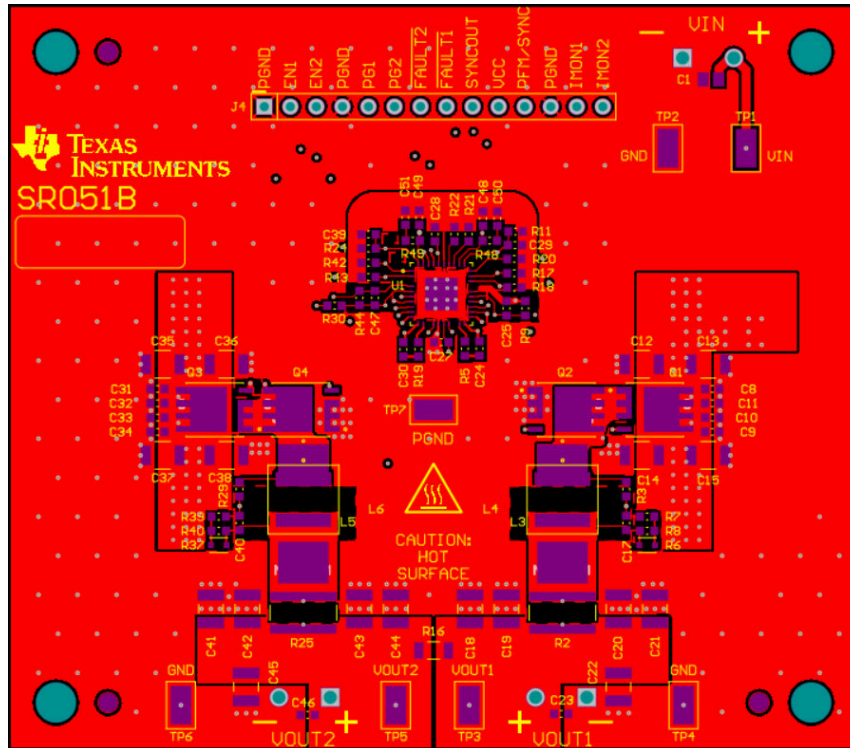

Figure 4-2. Top Copper (Top View)

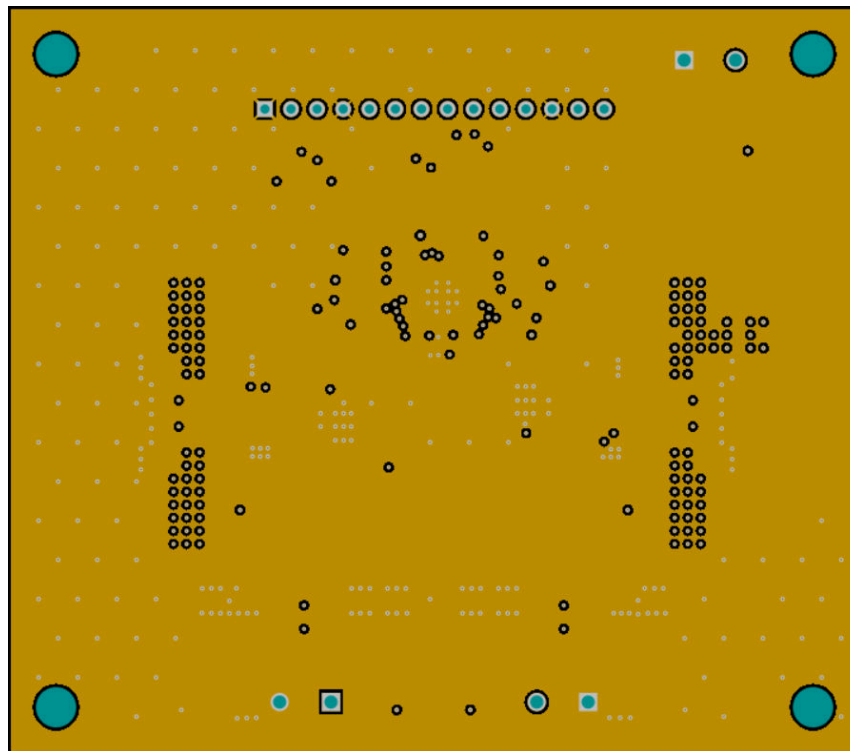

Figure 4-3. Layer 2 Copper (Top View)

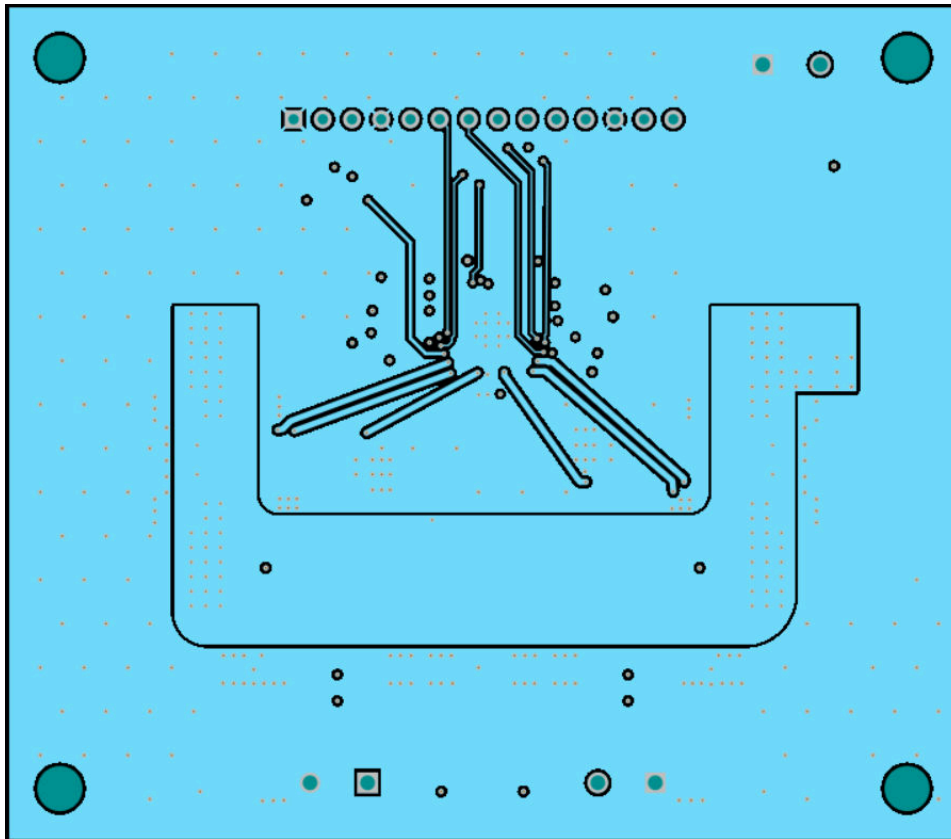

Figure 4-4. Layer 3 Copper (Top View)

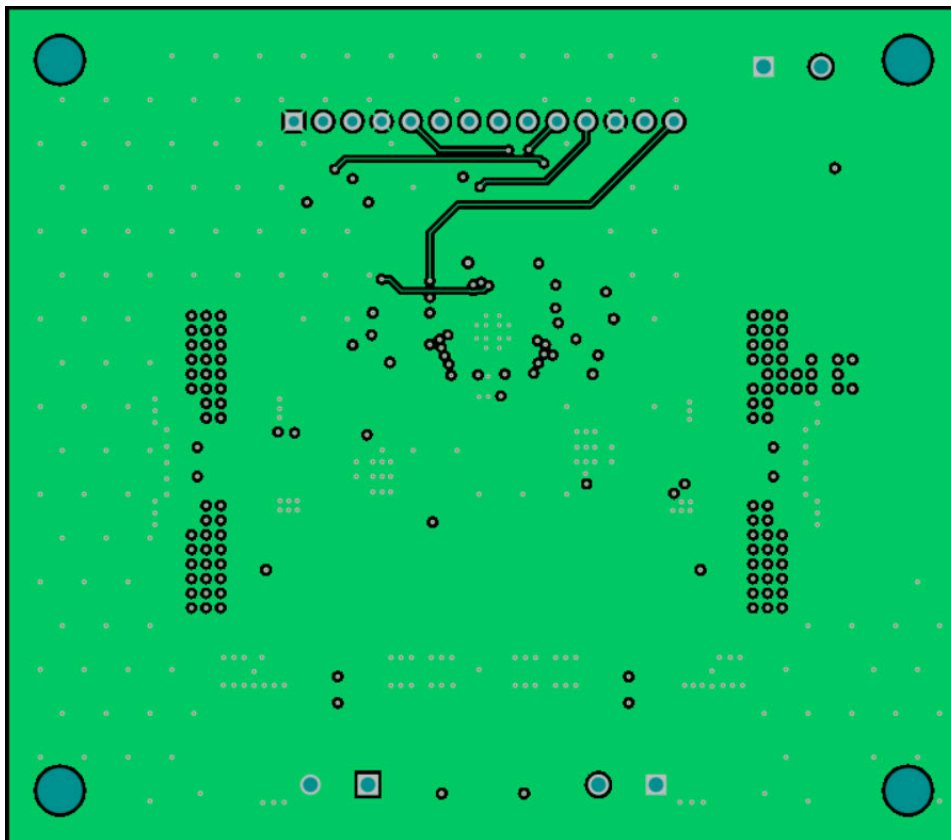

Figure 4-5. Layer 4 Copper (Top View)

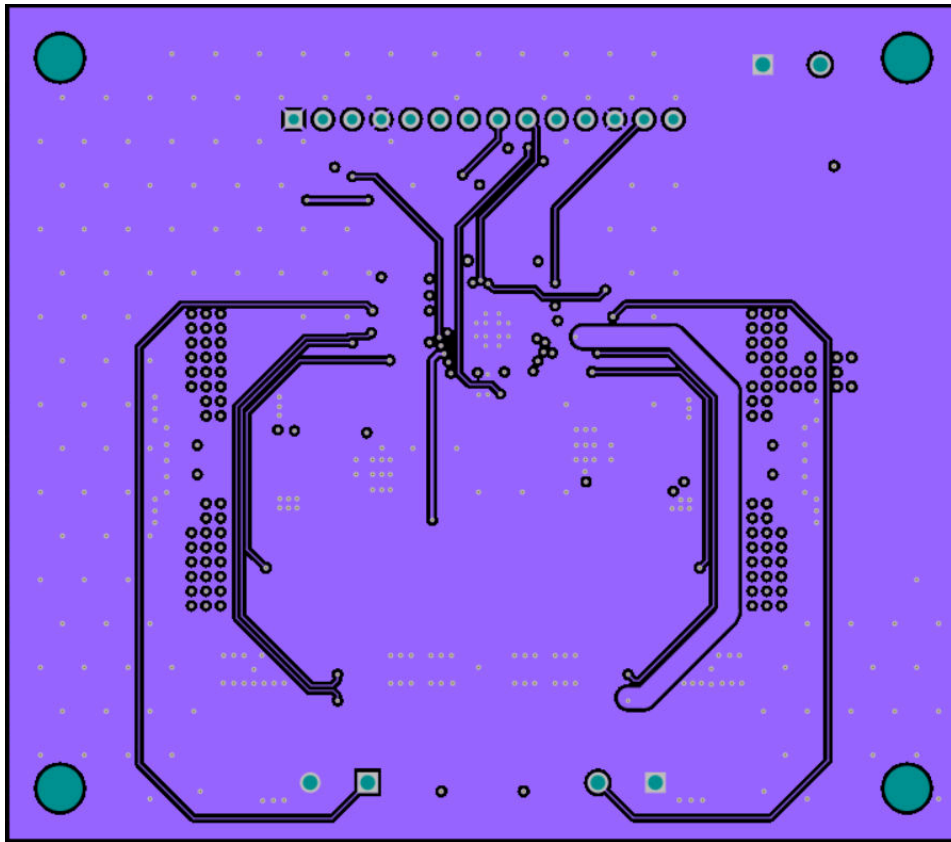

Figure 4-6. Layer 5 Copper (Top View)

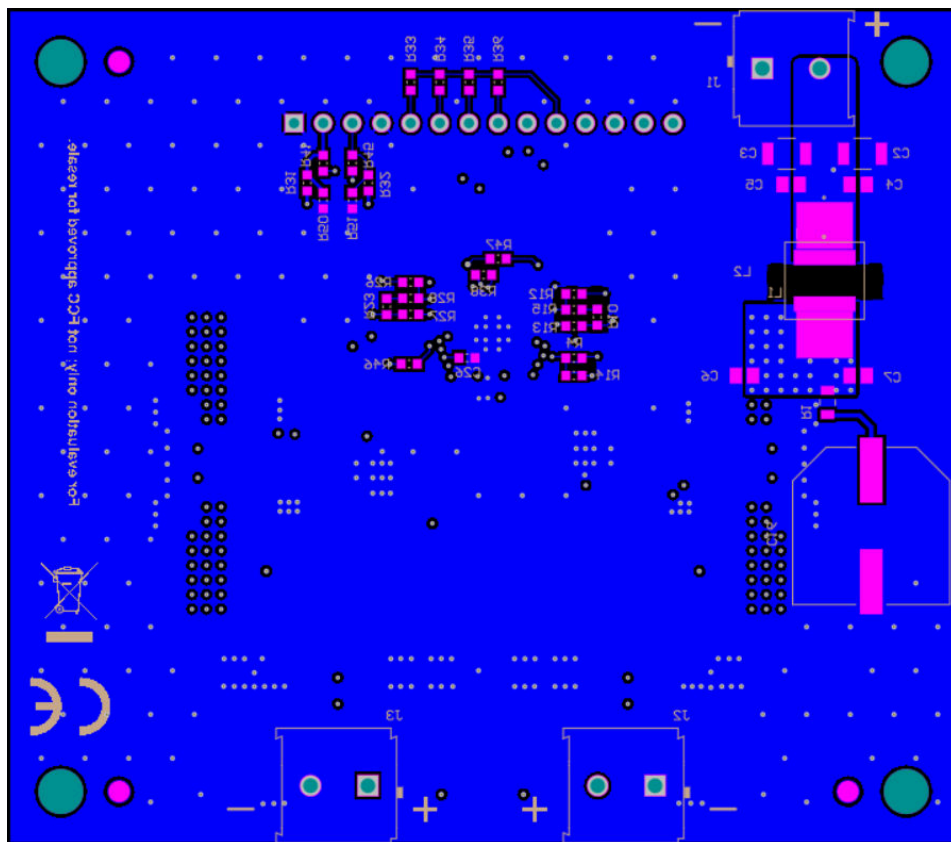

Figure 4-7. Bottom Copper (Top View)

4.2.1 Component Drawings

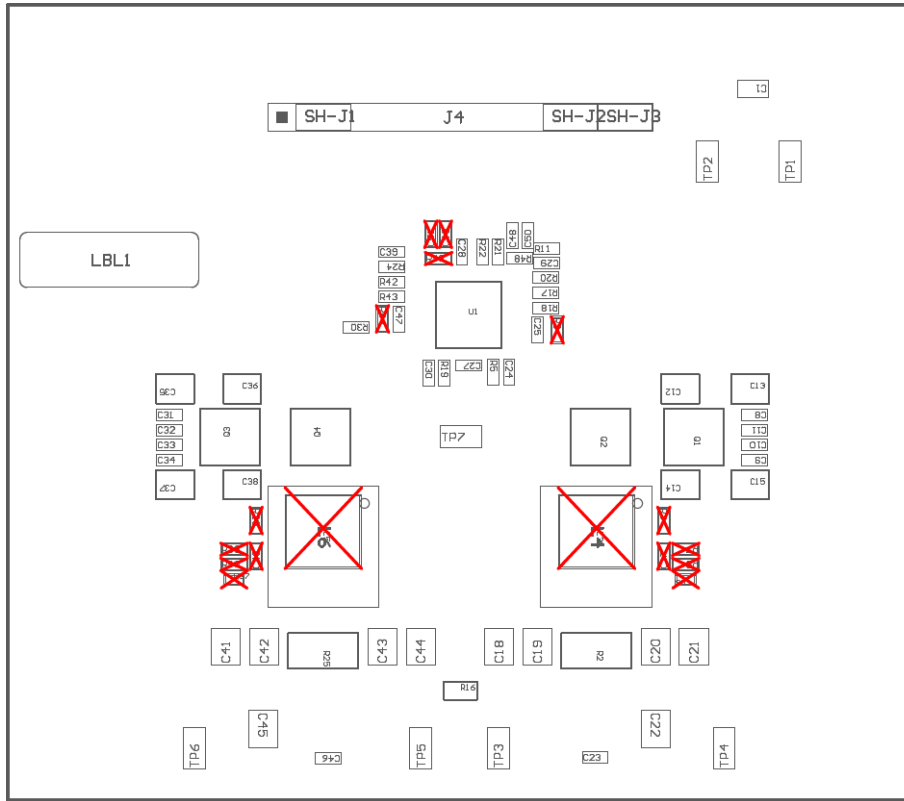

Figure 4-8. Top Component Drawing

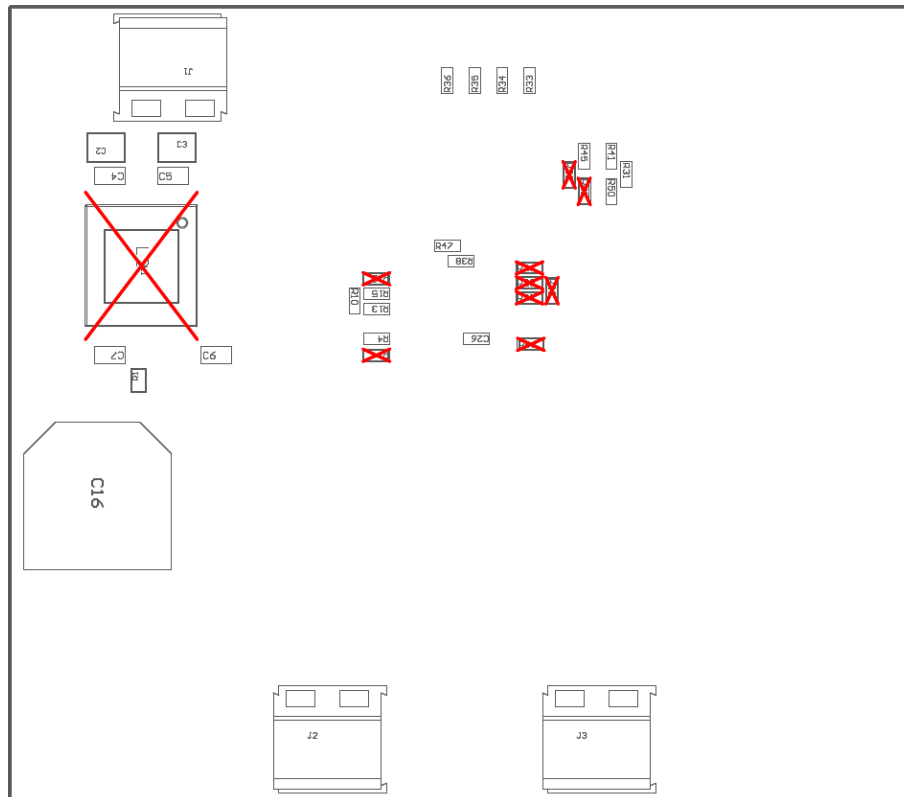

Figure 4-9. Bottom Component Drawing

4.2.2 Layout Guidelines

Figure 4-10 shows the top layer of the PCB with layer 2 as a power-loop ground return path directly underneath the top layer to create a low-area switching power loop of approximately 2mm². This loop area, and hence the associated parasitic inductance, must be as small as possible to minimize switch-node voltage overshoot and ringing (and thus the overall EMI signature).

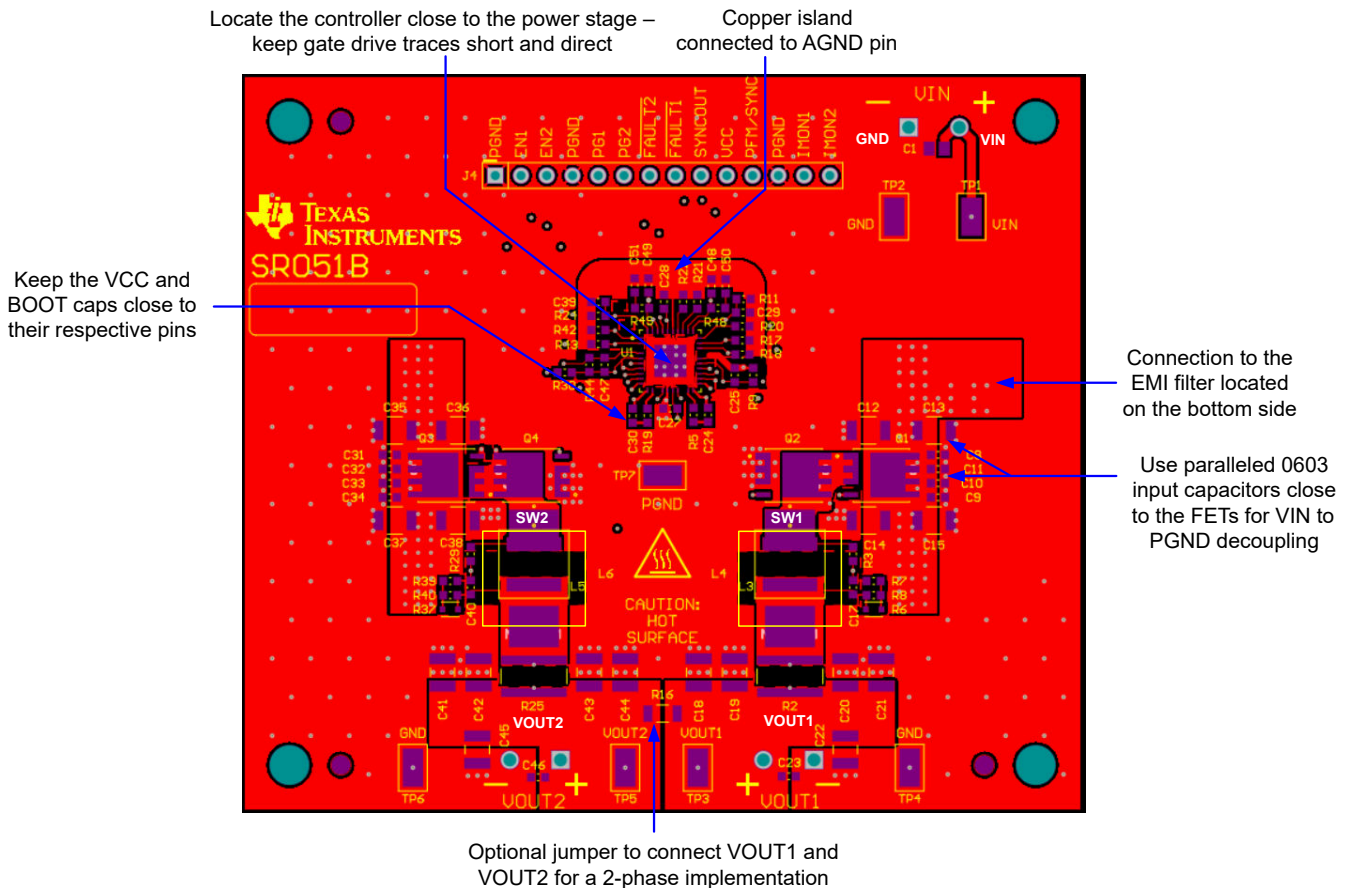

Figure 4-10. PCB Top Layer With Layout Guidelines

As shown in Figure 4-11, the high-frequency power loop current flows through MOSFETs Q3 and Q4, through the power ground plane on layer 2, and back to VIN through the 0603 ceramic capacitors C30 through C33. The currents flowing in opposing directions in the vertical loop configuration provide field self-cancellation, reducing parasitic loop inductance. Figure 4-12 shows a side view to illustrate the concept of creating a low-profile, self-canceling loop in a multilayer PCB structure. The layer-2 GND plane layer, shown in Figure 4-11, provides a tightly-coupled current return path directly under the MOSFETs to the source terminals of Q4.

Four 10nF input capacitors with small 0603 case size place in parallel close to the drain of each high-side MOSFET. The low ESL and high self-resonant frequency (SRF) of the small footprint capacitors yield excellent high-frequency performance. The negative terminals of these capacitors connect to the layer-2 GND plane with multiple 12mil (0.3mm) diameter vias, further reducing parasitic inductance.

The following list describes additional important steps in a layout design. Refer to the layout guidelines in the [LM5137-Q1 Automotive, 4V to 80V, 100% Duty Cycle Capable, Dual-Channel Synchronous Buck Controller](#) data sheet for more detail.

- Keep the SW connection from the power MOSFETs to the inductor (for each channel) at minimum copper area to reduce capacitive coupling and radiated EMI.
- Position the IC between the two phases and relatively close to the power MOSFET gate terminals. Route the gate drive traces short and direct, and keep HO and SW traces together to minimize gate loop parasitic inductance.

- Create an analog ground plane near the IC for sensitive analog components. Connect the AGND plane and the PGND power ground planes at a single point at the die attach pad (DAP) of the IC.
- Route the current sense traces from the shunt to the IC as a differential pair and keep away from noise sources, such as the switch node and gate drive traces. Increase the width of the trace to the BIAS/VOUT1 pin, as that trace carries the bias current for the IC.

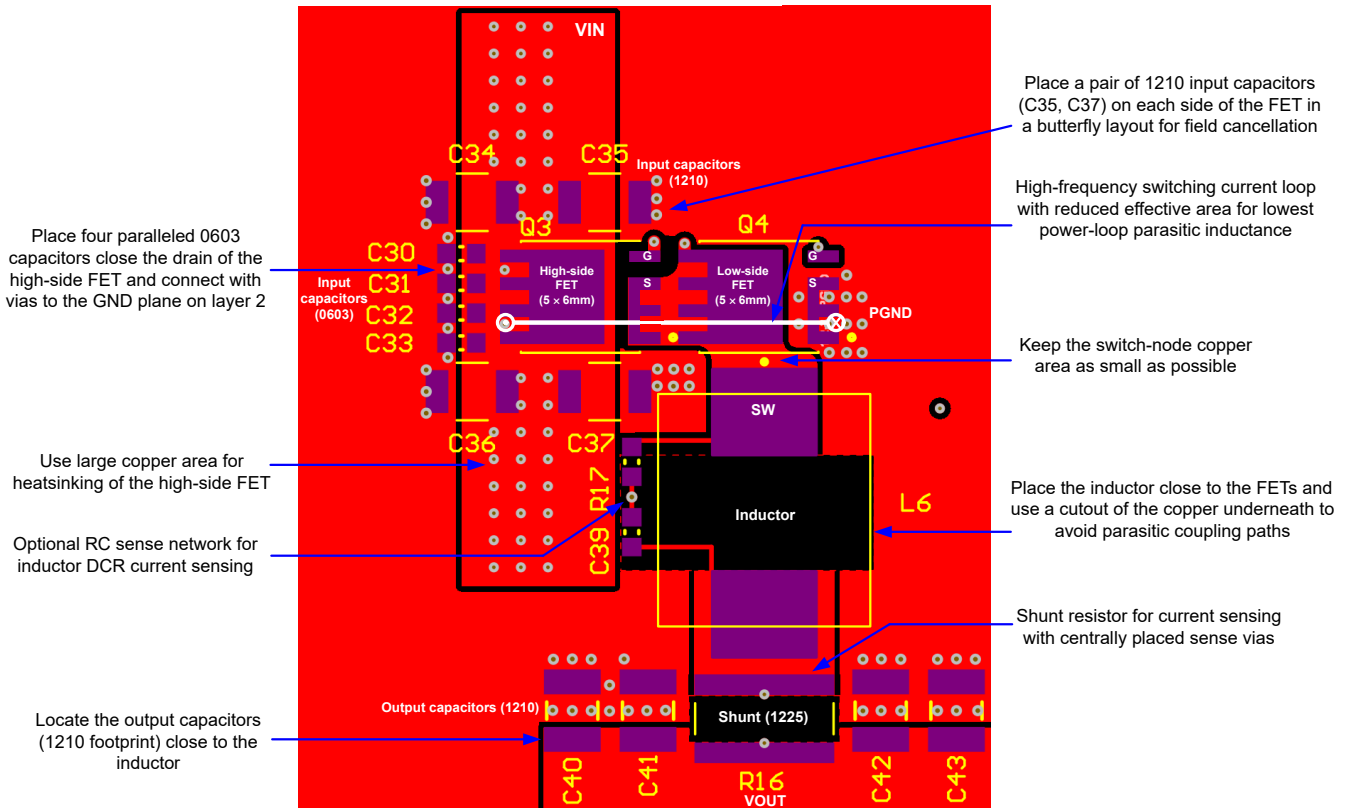
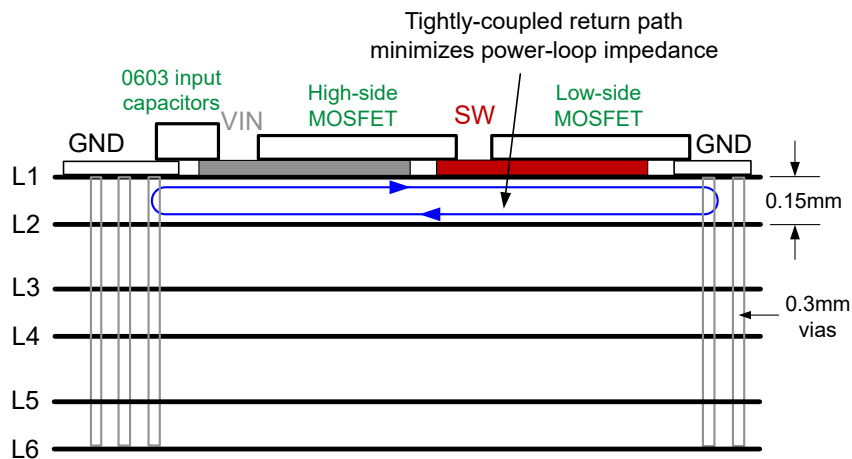

Figure 4-11. Power-Stage Component Layout



Note

Refer to the [Improve High-Current DC/DC Regulator EMI Performance for Free With Optimized Power Stage Layout](#) application brief for more detail.

Figure 4-12. PCB Stack-Up Diagram With Low L1-L2 Intra-layer Spacing

4.3 Bill of Materials

Table 4-1. Bill of Materials

COUNT	REF DES	DESCRIPTION	PART NUMBER	MFR
1	C1	Capacitor, ceramic, 0.1µF, 100V, X7R, 0805	Std	Std
10	C2, C3, C12, C13, C14, C15, C34, C35, C36, C37	Capacitor, ceramic, 4.7µF, 100V, X7S, 1210, AEC-Q200	GCM32DC72A475KE02L	Murata
			CGA6M3X7S2A475K200	TDK
4	C4, C5, C6, C7	Capacitor, ceramic, 470nF, 100V, X7R, 0805, AEC-Q200	GRM21BR72A474KA73L	Murata
8	C8, C9, C10, C11, C30, C31, C32, C33	Capacitor, ceramic, 10nF, 100V, X7R, 0603	GRM188R72A103KA01D	Murata
1	C16	Capacitor, electrolytic, 68µF, 100V, AEC-Q200	EEV-FK2A680Q	Panasonic
10	C18, C19, C20, C21, C22, C40, C41, C42, C43, C44	Capacitor, ceramic, 22µF, 25V, X7R, 1210, AEC-Q200	CGA6P3X7R1E226M250	TDK
		Capacitor, ceramic, 22µF, 25V, X7S, 1210, AEC-Q200	GCM32EC71E226KE36	Murata
6	C23, C24, C29, C30, C39, C46	Capacitor, ceramic, 0.1µF, 25V, X7R, 0603	Std	Std
1	C26	Capacitor, ceramic, 0.1µF, 100V, X7R, 0603	Std	Std
1	C27	Capacitor, ceramic, 4.7µF, 16V, X7R, 0603	Std	Std
1	C28	Capacitor, ceramic, 1µF, 16V, X7R, 0603	Std	Std
1	C48	Capacitor, ceramic, 22pF, 50V, C0G, 5%, 0603	Std	Std
1	C50	Capacitor, ceramic, 1.2nF, 50V, C0G, 10%, 0603	Std	Std
4	H1, H2, H3, H4	Hex standoff threaded #4-40 nylon 0.750", 3/4" natural	1902D	Keystone
4	H5, H6, H7, H8	#4-40 pan head machine screw Phillips drive nylon	NY PMS 440 0038 PH	Building Fasteners
2	J1, J2	Terminal block, 5mm, 2-pole, tin, TH	282856-2	TE Connectivity
1	J4	Header, 100mil, 14 × 1, Gold, TH	TSW-114-07-G-S	Samtec
1	L1	Inductor, 3.3µH, 13.4A, 5.9mΩ, AEC-Q200	XGL6060-332MEC	Coilcraft
2	L4, L6	Inductor, 5.6µH, 15A, 10mΩ, AEC-Q200	VCHW105D-5R6MS5	Cyntec
		Inductor, 5.6µH, 16.2A, 10.2mΩ, AEC-Q200	SRP1050WA-5R6M	Bourns
		Inductor, 4.7µH, 15.7A, 8.3mΩ, AEC-Q200	VCHA105D-4R7MS6	Cyntec
2	Q1, Q3	MOSFET, N-channel, 80V, 13.4mA, AEC-Q101	NVMFS6H852NLT1G	onsemi
2	Q2, Q4	MOSFET, N-channel, 80V, 6.2mA, AEC-Q101	NVMFS6H836NLT1G	onsemi
1	R1	Resistor, 0Ω, 0805	Std	Std
1	R2, R25	Resistor, 4mΩ, 3W, 2%, 1225, AEC-Q200	KRL6432E-M-R004-F-T1	Susumu
2	R4, R30	Resistor, 249Ω, 1/10W, 1%, 0603	Std	Std
5	R5, R19, R42, R43, R47	Resistor, 0Ω, 1/10W, 1%, 0603	Std	Std
1	R10	Resistor, 10Ω, 1/10W, 1%, 0603	Std	Std
3	R11, R24, R38	Resistor, 10kΩ, 1/10W, 1%, 0603	Std	Std
2	R13, R15	Resistor, 93.1kΩ, 1/10W, 1%, 0603	Std	Std
1	R16	0Ω jumper, 1206, metal element	5108	Keystone
2	R17, R18	Resistor, 6.65kΩ, 1/10W, 1%, 0603	Std	Std
2	R32, R33	Resistor, 15kΩ, 1/10W, 1%, 0603	Std	Std
1	R19	Resistor, 20kΩ, 1/10W, 1%, 0603	Std	Std
1	R20	Resistor, 71.5kΩ, 1/10W, 1%, 0603	Std	Std
1	R21	Resistor, 20kΩ, 1/10W, 1%, 0603	Std	Std
1	R22	Resistor, 57.6kΩ, 1/10W, 1%, 0603	Std	Std
2	R21, R22	Resistor, 226kΩ, 1/10W, 1%, 0603	Std	Std
3	R31, R33, R34	Resistor, 100kΩ, 1/10W, 1%, 0603	Std	Std
2	R35, R36	Resistor, 15kΩ, 1/10W, 1%, 0603	Std	Std
2	R41, R45	Resistor, 4.99kΩ, 1/10W, 1%, 0603	Std	Std
1	R48	Resistor, 14kΩ, 1/10W, 1%, 0603	Std	Std
3	SH-J1, SH-J2, SH-J3	Open top jumper socket, 2.54mm pitch	M7582-05	Harwin
7	TP1, TP2, TP3, TP4, TP5, TP6, TP7	Test point, miniature, SMT	5019	Keystone
1	U1	IC, LM5137F-Q1 , 80V dual synchronous buck controller, VQFN-36	LM5137FDQRHARQ1	TI
1	PCB1	PCB, FR4, 6 layer, 2oz, 84mm × 74mm	PCB	–

5 Additional Information

5.1 Trademarks

PowerPAD™ is a trademark of Texas Instruments.
WEBENCH® is a registered trademark of Texas Instruments.
All trademarks are the property of their respective owners.

6 Device and Documentation Support

6.1 Device Support

6.1.1 Development Support

For development support, see the following:

- For TI's reference design library, visit [TI Designs](#).
- For TI's WEBENCH design environments, visit the [WEBENCH® Design Center](#).
- LM(2)5137(F)-Q1 DC/DC controller [quickstart calculator](#) and [PSPICE](#) simulation models.

6.2 Documentation Support

6.2.1 Related Documentation

For related documentation, see the following:

- Texas Instruments, [LM5137-Q1 Automotive, 4V to 80V, 100% Duty Cycle Capable, Dual-Channel Synchronous Buck Controller](#) data sheet
- Texas Instruments, [LM25137-Q1 Evaluation Module](#) EVM user's guide
- Technical articles:
 - Texas Instruments, [Achieving functional safety compliance in automotive off-battery buck preregulator designs](#)
 - Texas Instruments, [Powering next-generation ADAS processors with TI Functional Safety-Compliant buck regulators](#)

6.2.1.1 Low-EMI Design Resources

- Texas Instruments, [Low EMI](#) landing page
- Texas Instruments, [An Engineer's Guide to Low EMI in DC/DC Regulators](#) e-book
- Applications notes:
 - Texas Instruments, [Improve High-Current DC/DC Regulator Low EMI for Free With Optimized Power Stage Layout](#)
 - Texas Instruments, [Reduce Buck Converter EMI and Voltage Stress by Minimizing Inductive Parasitics](#)
- White papers:
 - Texas Instruments, [An Overview of Conducted EMI Specifications for Power Supplies](#)
 - Texas Instruments, [An Overview of Radiated EMI Specifications for Power Supplies](#)
 - Texas Instruments, [Time-Saving and Cost-Effective Innovations for EMI Reduction in Power Supplies](#)
 - Texas Instruments, [Valuing Wide \$V_{IN}\$, Low EMI Synchronous Buck Circuits for Cost-driven, Demanding Applications](#)

6.2.1.2 PCB Layout Resources

- LM5137F-Q1-EVM12V [Altium layout source files](#)
- Applications notes:
 - Texas Instruments, [Improve High-Current DC/DC Regulator EMI Performance for Free With Optimized Power Stage Layout](#)
 - Texas Instruments, [AN-1149 Layout Guidelines for Switching Power Supplies](#)
- Texas Instruments, [Constructing Your Power Supply – Layout Considerations](#) seminar

6.2.1.3 Thermal Design Resources

- White paper:
 - Texas Instruments, [Improving Thermal Performance in High Ambient Temperature Environments With Thermally Enhanced Packaging](#)
- Applications notes:

- Texas Instruments, [*Thermal Design by Insight, Not Hindsight*](#)
- Texas Instruments, [*A Guide to Board Layout for Best Thermal Resistance for Exposed Pad Packages*](#)
- Texas Instruments, [*Semiconductor and IC Package Thermal Metrics*](#)
- Texas Instruments, [*PowerPAD™ Thermally Enhanced Package*](#)
- Texas Instruments, [*PowerPAD™ Made Easy*](#)
- Texas Instruments, [*Using New Thermal Metrics*](#)

STANDARD TERMS FOR EVALUATION MODULES

1. *Delivery:* TI delivers TI evaluation boards, kits, or modules, including any accompanying demonstration software, components, and/or documentation which may be provided together or separately (collectively, an "EVM" or "EVMs") to the User ("User") in accordance with the terms set forth herein. User's acceptance of the EVM is expressly subject to the following terms.
 - 1.1 EVMs are intended solely for product or software developers for use in a research and development setting to facilitate feasibility evaluation, experimentation, or scientific analysis of TI semiconductors products. EVMs have no direct function and are not finished products. EVMs shall not be directly or indirectly assembled as a part or subassembly in any finished product. For clarification, any software or software tools provided with the EVM ("Software") shall not be subject to the terms and conditions set forth herein but rather shall be subject to the applicable terms that accompany such Software
 - 1.2 EVMs are not intended for consumer or household use. EVMs may not be sold, sublicensed, leased, rented, loaned, assigned, or otherwise distributed for commercial purposes by Users, in whole or in part, or used in any finished product or production system.
2. *Limited Warranty and Related Remedies/Disclaimers:*
 - 2.1 These terms do not apply to Software. The warranty, if any, for Software is covered in the applicable Software License Agreement.
 - 2.2 TI warrants that the TI EVM will conform to TI's published specifications for ninety (90) days after the date TI delivers such EVM to User. Notwithstanding the foregoing, TI shall not be liable for a nonconforming EVM if (a) the nonconformity was caused by neglect, misuse or mistreatment by an entity other than TI, including improper installation or testing, or for any EVMs that have been altered or modified in any way by an entity other than TI, (b) the nonconformity resulted from User's design, specifications or instructions for such EVMs or improper system design, or (c) User has not paid on time. Testing and other quality control techniques are used to the extent TI deems necessary. TI does not test all parameters of each EVM. User's claims against TI under this Section 2 are void if User fails to notify TI of any apparent defects in the EVMs within ten (10) business days after delivery, or of any hidden defects with ten (10) business days after the defect has been detected.
 - 2.3 TI's sole liability shall be at its option to repair or replace EVMs that fail to conform to the warranty set forth above, or credit User's account for such EVM. TI's liability under this warranty shall be limited to EVMs that are returned during the warranty period to the address designated by TI and that are determined by TI not to conform to such warranty. If TI elects to repair or replace such EVM, TI shall have a reasonable time to repair such EVM or provide replacements. Repaired EVMs shall be warranted for the remainder of the original warranty period. Replaced EVMs shall be warranted for a new full ninety (90) day warranty period.

WARNING

Evaluation Kits are intended solely for use by technically qualified, professional electronics experts who are familiar with the dangers and application risks associated with handling electrical mechanical components, systems, and subsystems.

User shall operate the Evaluation Kit within TI's recommended guidelines and any applicable legal or environmental requirements as well as reasonable and customary safeguards. Failure to set up and/or operate the Evaluation Kit within TI's recommended guidelines may result in personal injury or death or property damage. Proper set up entails following TI's instructions for electrical ratings of interface circuits such as input, output and electrical loads.

NOTE:

EXPOSURE TO ELECTROSTATIC DISCHARGE (ESD) MAY CAUSE DEGRADATION OR FAILURE OF THE EVALUATION KIT; TI RECOMMENDS STORAGE OF THE EVALUATION KIT IN A PROTECTIVE ESD BAG.

3 Regulatory Notices:

3.1 United States

3.1.1 Notice applicable to EVMs not FCC-Approved:

FCC NOTICE: This kit is designed to allow product developers to evaluate electronic components, circuitry, or software associated with the kit to determine whether to incorporate such items in a finished product and software developers to write software applications for use with the end product. This kit is not a finished product and when assembled may not be resold or otherwise marketed unless all required FCC equipment authorizations are first obtained. Operation is subject to the condition that this product not cause harmful interference to licensed radio stations and that this product accept harmful interference. Unless the assembled kit is designed to operate under part 15, part 18 or part 95 of this chapter, the operator of the kit must operate under the authority of an FCC license holder or must secure an experimental authorization under part 5 of this chapter.

3.1.2 For EVMs annotated as FCC – FEDERAL COMMUNICATIONS COMMISSION Part 15 Compliant:

CAUTION

This device complies with part 15 of the FCC Rules. Operation is subject to the following two conditions: (1) This device may not cause harmful interference, and (2) this device must accept any interference received, including interference that may cause undesired operation.

Changes or modifications not expressly approved by the party responsible for compliance could void the user's authority to operate the equipment.

FCC Interference Statement for Class A EVM devices

NOTE: This equipment has been tested and found to comply with the limits for a Class A digital device, pursuant to part 15 of the FCC Rules. These limits are designed to provide reasonable protection against harmful interference when the equipment is operated in a commercial environment. This equipment generates, uses, and can radiate radio frequency energy and, if not installed and used in accordance with the instruction manual, may cause harmful interference to radio communications. Operation of this equipment in a residential area is likely to cause harmful interference in which case the user will be required to correct the interference at his own expense.

FCC Interference Statement for Class B EVM devices

NOTE: This equipment has been tested and found to comply with the limits for a Class B digital device, pursuant to part 15 of the FCC Rules. These limits are designed to provide reasonable protection against harmful interference in a residential installation. This equipment generates, uses and can radiate radio frequency energy and, if not installed and used in accordance with the instructions, may cause harmful interference to radio communications. However, there is no guarantee that interference will not occur in a particular installation. If this equipment does cause harmful interference to radio or television reception, which can be determined by turning the equipment off and on, the user is encouraged to try to correct the interference by one or more of the following measures:

- Reorient or relocate the receiving antenna.
- Increase the separation between the equipment and receiver.
- Connect the equipment into an outlet on a circuit different from that to which the receiver is connected.
- Consult the dealer or an experienced radio/TV technician for help.

3.2 Canada

3.2.1 For EVMs issued with an Industry Canada Certificate of Conformance to RSS-210 or RSS-247

Concerning EVMs Including Radio Transmitters:

This device complies with Industry Canada license-exempt RSSs. Operation is subject to the following two conditions:

(1) this device may not cause interference, and (2) this device must accept any interference, including interference that may cause undesired operation of the device.

Concernant les EVMs avec appareils radio:

Le présent appareil est conforme aux CNR d'Industrie Canada applicables aux appareils radio exempts de licence. L'exploitation est autorisée aux deux conditions suivantes: (1) l'appareil ne doit pas produire de brouillage, et (2) l'utilisateur de l'appareil doit accepter tout brouillage radioélectrique subi, même si le brouillage est susceptible d'en compromettre le fonctionnement.

Concerning EVMs Including Detachable Antennas:

Under Industry Canada regulations, this radio transmitter may only operate using an antenna of a type and maximum (or lesser) gain approved for the transmitter by Industry Canada. To reduce potential radio interference to other users, the antenna type and its gain should be so chosen that the equivalent isotropically radiated power (e.i.r.p.) is not more than that necessary for successful communication. This radio transmitter has been approved by Industry Canada to operate with the antenna types listed in the user guide with the maximum permissible gain and required antenna impedance for each antenna type indicated. Antenna types not included in this list, having a gain greater than the maximum gain indicated for that type, are strictly prohibited for use with this device.

Concernant les EVMs avec antennes détachables

Conformément à la réglementation d'Industrie Canada, le présent émetteur radio peut fonctionner avec une antenne d'un type et d'un gain maximal (ou inférieur) approuvé pour l'émetteur par Industrie Canada. Dans le but de réduire les risques de brouillage radioélectrique à l'intention des autres utilisateurs, il faut choisir le type d'antenne et son gain de sorte que la puissance isotrope rayonnée équivalente (p.i.r.e.) ne dépasse pas l'intensité nécessaire à l'établissement d'une communication satisfaisante. Le présent émetteur radio a été approuvé par Industrie Canada pour fonctionner avec les types d'antenne énumérés dans le manuel d'usage et ayant un gain admissible maximal et l'impédance requise pour chaque type d'antenne. Les types d'antenne non inclus dans cette liste, ou dont le gain est supérieur au gain maximal indiqué, sont strictement interdits pour l'exploitation de l'émetteur.

3.3 Japan

3.3.1 *Notice for EVMs delivered in Japan:* Please see http://www.tij.co.jp/lstds/ti_ja/general/eStore/notice_01.page 日本国内に輸入される評価用キット、ボードについては、次のところをご覧ください。

<https://www.ti.com/ja-jp/legal/notice-for-evaluation-kits-delivered-in-japan.html>

3.3.2 *Notice for Users of EVMs Considered "Radio Frequency Products" in Japan:* EVMs entering Japan may not be certified by TI as conforming to Technical Regulations of Radio Law of Japan.

If User uses EVMs in Japan, not certified to Technical Regulations of Radio Law of Japan, User is required to follow the instructions set forth by Radio Law of Japan, which includes, but is not limited to, the instructions below with respect to EVMs (which for the avoidance of doubt are stated strictly for convenience and should be verified by User):

1. Use EVMs in a shielded room or any other test facility as defined in the notification #173 issued by Ministry of Internal Affairs and Communications on March 28, 2006, based on Sub-section 1.1 of Article 6 of the Ministry's Rule for Enforcement of Radio Law of Japan,
2. Use EVMs only after User obtains the license of Test Radio Station as provided in Radio Law of Japan with respect to EVMs, or
3. Use of EVMs only after User obtains the Technical Regulations Conformity Certification as provided in Radio Law of Japan with respect to EVMs. Also, do not transfer EVMs, unless User gives the same notice above to the transferee. Please note that if User does not follow the instructions above, User will be subject to penalties of Radio Law of Japan.

【無線電波を送信する製品の開発キットをお使いになる際の注意事項】 開発キットの中には技術基準適合証明を受けていないものがあります。技術適合証明を受けていないものご使用に際しては、電波法遵守のため、以下のいずれかの措置を取っていただく必要がありますのでご注意ください。

1. 電波法施行規則第6条第1項第1号に基づく平成18年3月28日総務省告示第173号で定められた電波暗室等の試験設備でご使用いただく。
2. 実験局の免許を取得後ご使用いただく。
3. 技術基準適合証明を取得後ご使用いただく。

なお、本製品は、上記の「ご使用にあたっての注意」を譲渡先、移転先に通知しない限り、譲渡、移転できないものとします。

上記を遵守頂けない場合は、電波法の罰則が適用される可能性があることをご留意ください。日本テキサス・イ

ンスツルメンツ株式会社

東京都新宿区西新宿 6 丁目 2 4 番 1 号

西新宿三井ビル

3.3.3 *Notice for EVMs for Power Line Communication:* Please see http://www.tij.co.jp/lstds/ti_ja/general/eStore/notice_02.page

電力線搬送波通信についての開発キットをお使いになる際の注意事項については、次のところをご覧ください。 <https://www.ti.com/ja-jp/legal/notice-for-evaluation-kits-for-power-line-communication.html>

3.4 European Union

3.4.1 *For EVMs subject to EU Directive 2014/30/EU (Electromagnetic Compatibility Directive):*

This is a class A product intended for use in environments other than domestic environments that are connected to a low-voltage power-supply network that supplies buildings used for domestic purposes. In a domestic environment this product may cause radio interference in which case the user may be required to take adequate measures.

-
4. *EVM Use Restrictions and Warnings:*
 - 4.1 EVMS ARE NOT FOR USE IN FUNCTIONAL SAFETY AND/OR SAFETY CRITICAL EVALUATIONS, INCLUDING BUT NOT LIMITED TO EVALUATIONS OF LIFE SUPPORT APPLICATIONS.
 - 4.2 User must read and apply the user guide and other available documentation provided by TI regarding the EVM prior to handling or using the EVM, including without limitation any warning or restriction notices. The notices contain important safety information related to, for example, temperatures and voltages.
 - 4.3 *Safety-Related Warnings and Restrictions:*
 - 4.3.1 User shall operate the EVM within TI's recommended specifications and environmental considerations stated in the user guide, other available documentation provided by TI, and any other applicable requirements and employ reasonable and customary safeguards. Exceeding the specified performance ratings and specifications (including but not limited to input and output voltage, current, power, and environmental ranges) for the EVM may cause personal injury or death, or property damage. If there are questions concerning performance ratings and specifications, User should contact a TI field representative prior to connecting interface electronics including input power and intended loads. Any loads applied outside of the specified output range may also result in unintended and/or inaccurate operation and/or possible permanent damage to the EVM and/or interface electronics. Please consult the EVM user guide prior to connecting any load to the EVM output. If there is uncertainty as to the load specification, please contact a TI field representative. During normal operation, even with the inputs and outputs kept within the specified allowable ranges, some circuit components may have elevated case temperatures. These components include but are not limited to linear regulators, switching transistors, pass transistors, current sense resistors, and heat sinks, which can be identified using the information in the associated documentation. When working with the EVM, please be aware that the EVM may become very warm.
 - 4.3.2 EVMs are intended solely for use by technically qualified, professional electronics experts who are familiar with the dangers and application risks associated with handling electrical mechanical components, systems, and subsystems. User assumes all responsibility and liability for proper and safe handling and use of the EVM by User or its employees, affiliates, contractors or designees. User assumes all responsibility and liability to ensure that any interfaces (electronic and/or mechanical) between the EVM and any human body are designed with suitable isolation and means to safely limit accessible leakage currents to minimize the risk of electrical shock hazard. User assumes all responsibility and liability for any improper or unsafe handling or use of the EVM by User or its employees, affiliates, contractors or designees.
 - 4.4 User assumes all responsibility and liability to determine whether the EVM is subject to any applicable international, federal, state, or local laws and regulations related to User's handling and use of the EVM and, if applicable, User assumes all responsibility and liability for compliance in all respects with such laws and regulations. User assumes all responsibility and liability for proper disposal and recycling of the EVM consistent with all applicable international, federal, state, and local requirements.
 5. *Accuracy of Information:* To the extent TI provides information on the availability and function of EVMs, TI attempts to be as accurate as possible. However, TI does not warrant the accuracy of EVM descriptions, EVM availability or other information on its websites as accurate, complete, reliable, current, or error-free.
 6. *Disclaimers:*
 - 6.1 EXCEPT AS SET FORTH ABOVE, EVMS AND ANY MATERIALS PROVIDED WITH THE EVM (INCLUDING, BUT NOT LIMITED TO, REFERENCE DESIGNS AND THE DESIGN OF THE EVM ITSELF) ARE PROVIDED "AS IS" AND "WITH ALL FAULTS." TI DISCLAIMS ALL OTHER WARRANTIES, EXPRESS OR IMPLIED, REGARDING SUCH ITEMS, INCLUDING BUT NOT LIMITED TO ANY EPIDEMIC FAILURE WARRANTY OR IMPLIED WARRANTIES OF MERCHANTABILITY OR FITNESS FOR A PARTICULAR PURPOSE OR NON-INFRINGEMENT OF ANY THIRD PARTY PATENTS, COPYRIGHTS, TRADE SECRETS OR OTHER INTELLECTUAL PROPERTY RIGHTS.
 - 6.2 EXCEPT FOR THE LIMITED RIGHT TO USE THE EVM SET FORTH HEREIN, NOTHING IN THESE TERMS SHALL BE CONSTRUED AS GRANTING OR CONFERRING ANY RIGHTS BY LICENSE, PATENT, OR ANY OTHER INDUSTRIAL OR INTELLECTUAL PROPERTY RIGHT OF TI, ITS SUPPLIERS/LICENSORS OR ANY OTHER THIRD PARTY, TO USE THE EVM IN ANY FINISHED END-USER OR READY-TO-USE FINAL PRODUCT, OR FOR ANY INVENTION, DISCOVERY OR IMPROVEMENT, REGARDLESS OF WHEN MADE, CONCEIVED OR ACQUIRED.
 7. *USER'S INDEMNITY OBLIGATIONS AND REPRESENTATIONS.* USER WILL DEFEND, INDEMNIFY AND HOLD TI, ITS LICENSORS AND THEIR REPRESENTATIVES HARMLESS FROM AND AGAINST ANY AND ALL CLAIMS, DAMAGES, LOSSES, EXPENSES, COSTS AND LIABILITIES (COLLECTIVELY, "CLAIMS") ARISING OUT OF OR IN CONNECTION WITH ANY HANDLING OR USE OF THE EVM THAT IS NOT IN ACCORDANCE WITH THESE TERMS. THIS OBLIGATION SHALL APPLY WHETHER CLAIMS ARISE UNDER STATUTE, REGULATION, OR THE LAW OF TORT, CONTRACT OR ANY OTHER LEGAL THEORY, AND EVEN IF THE EVM FAILS TO PERFORM AS DESCRIBED OR EXPECTED.

8. *Limitations on Damages and Liability:*

8.1 *General Limitations.* IN NO EVENT SHALL TI BE LIABLE FOR ANY SPECIAL, COLLATERAL, INDIRECT, PUNITIVE, INCIDENTAL, CONSEQUENTIAL, OR EXEMPLARY DAMAGES IN CONNECTION WITH OR ARISING OUT OF THESE TERMS OR THE USE OF THE EVMS , REGARDLESS OF WHETHER TI HAS BEEN ADVISED OF THE POSSIBILITY OF SUCH DAMAGES. EXCLUDED DAMAGES INCLUDE, BUT ARE NOT LIMITED TO, COST OF REMOVAL OR REINSTALLATION, ANCILLARY COSTS TO THE PROCUREMENT OF SUBSTITUTE GOODS OR SERVICES, RETESTING, OUTSIDE COMPUTER TIME, LABOR COSTS, LOSS OF GOODWILL, LOSS OF PROFITS, LOSS OF SAVINGS, LOSS OF USE, LOSS OF DATA, OR BUSINESS INTERRUPTION. NO CLAIM, SUIT OR ACTION SHALL BE BROUGHT AGAINST TI MORE THAN TWELVE (12) MONTHS AFTER THE EVENT THAT GAVE RISE TO THE CAUSE OF ACTION HAS OCCURRED.

8.2 *Specific Limitations.* IN NO EVENT SHALL TI'S AGGREGATE LIABILITY FROM ANY USE OF AN EVM PROVIDED HEREUNDER, INCLUDING FROM ANY WARRANTY, INDEMNITY OR OTHER OBLIGATION ARISING OUT OF OR IN CONNECTION WITH THESE TERMS, , EXCEED THE TOTAL AMOUNT PAID TO TI BY USER FOR THE PARTICULAR EVM(S) AT ISSUE DURING THE PRIOR TWELVE (12) MONTHS WITH RESPECT TO WHICH LOSSES OR DAMAGES ARE CLAIMED. THE EXISTENCE OF MORE THAN ONE CLAIM SHALL NOT ENLARGE OR EXTEND THIS LIMIT.

9. *Return Policy.* Except as otherwise provided, TI does not offer any refunds, returns, or exchanges. Furthermore, no return of EVM(s) will be accepted if the package has been opened and no return of the EVM(s) will be accepted if they are damaged or otherwise not in a resalable condition. If User feels it has been incorrectly charged for the EVM(s) it ordered or that delivery violates the applicable order, User should contact TI. All refunds will be made in full within thirty (30) working days from the return of the components(s), excluding any postage or packaging costs.

10. *Governing Law:* These terms and conditions shall be governed by and interpreted in accordance with the laws of the State of Texas, without reference to conflict-of-laws principles. User agrees that non-exclusive jurisdiction for any dispute arising out of or relating to these terms and conditions lies within courts located in the State of Texas and consents to venue in Dallas County, Texas. Notwithstanding the foregoing, any judgment may be enforced in any United States or foreign court, and TI may seek injunctive relief in any United States or foreign court.

Mailing Address: Texas Instruments, Post Office Box 655303, Dallas, Texas 75265
Copyright © 2023, Texas Instruments Incorporated

IMPORTANT NOTICE AND DISCLAIMER

TI PROVIDES TECHNICAL AND RELIABILITY DATA (INCLUDING DATA SHEETS), DESIGN RESOURCES (INCLUDING REFERENCE DESIGNS), APPLICATION OR OTHER DESIGN ADVICE, WEB TOOLS, SAFETY INFORMATION, AND OTHER RESOURCES "AS IS" AND WITH ALL FAULTS, AND DISCLAIMS ALL WARRANTIES, EXPRESS AND IMPLIED, INCLUDING WITHOUT LIMITATION ANY IMPLIED WARRANTIES OF MERCHANTABILITY, FITNESS FOR A PARTICULAR PURPOSE OR NON-INFRINGEMENT OF THIRD PARTY INTELLECTUAL PROPERTY RIGHTS.

These resources are intended for skilled developers designing with TI products. You are solely responsible for (1) selecting the appropriate TI products for your application, (2) designing, validating and testing your application, and (3) ensuring your application meets applicable standards, and any other safety, security, regulatory or other requirements.

These resources are subject to change without notice. TI grants you permission to use these resources only for development of an application that uses the TI products described in the resource. Other reproduction and display of these resources is prohibited. No license is granted to any other TI intellectual property right or to any third party intellectual property right. TI disclaims responsibility for, and you will fully indemnify TI and its representatives against, any claims, damages, costs, losses, and liabilities arising out of your use of these resources.

TI's products are provided subject to [TI's Terms of Sale](#) or other applicable terms available either on [ti.com](https://www.ti.com) or provided in conjunction with such TI products. TI's provision of these resources does not expand or otherwise alter TI's applicable warranties or warranty disclaimers for TI products.

TI objects to and rejects any additional or different terms you may have proposed.

Mailing Address: Texas Instruments, Post Office Box 655303, Dallas, Texas 75265

Copyright © 2025, Texas Instruments Incorporated