

# Interference Mitigation on the AWR294x Transceiver



## ABSTRACT

The AWR294x transceiver is an integrated radar-on-a-chip device having not just the RF, analog, and ADC circuits but also a number of processing cores on the die. It has a specialized radar signal processing accelerator (called the hardware accelerator or HWA) with features enabling the detection and mitigation of radar-radar interference. This document introduces the mechanism of the most common kind of interference (called crossing interference), and shows how the Texas Instruments HWA can be configured to detect and heal such interference in-line.

Crossing Interference typically results in an increase in the noise floor, which can cause missed detections.

---

## Table of Contents

<b>1 Introduction</b> .....	2
<b>2 Crossing Interference</b> .....	2
2.1 Performance Analysis for Crossing Interference.....	4
<b>3 Localization and Mitigation on the Hardware Accelerator (HWA)</b> .....	5
3.1 Interference Statistics.....	6
3.2 Localization Module.....	8
3.3 Mitigation.....	8
<b>4 Summary</b> .....	9
<b>5 References</b> .....	9

## List of Figures

Figure 2-1. Crossing Interference Causing a Glitch in the Time Domain Signal.....	3
Figure 3-1. Different Accelerators Available in the HWA.....	5
Figure 3-2. Interference Mitigation Flow.....	6
Figure 3-3. Detecting Outliers Using Abs and Abs-diff Filters.....	7
Figure 3-4. Different Mitigation Approaches.....	8

## Trademarks

All trademarks are the property of their respective owners.

## 1 Introduction

The most common FMCW radar to FMCW radar interference happens when the transmitted chirp from a radar (called an aggressor) crosses the chirp of another radar's receiver (called the Victim). In this context, the term crossing is meant to indicate that the instantaneous RF frequencies of both the devices are equal at a certain point of time. In such a case, the Aggressor's signal will not be rejected by any of the filters on the Victim's receiver. The Aggressor's chirp will be down-converted, digitized and send out as part of ADC data.

In the ADC data, the duration during which the crossing occurs will have glitch – whose amplitude is related to the distance between the Aggressor and the Victim, as well as the antenna gain of both the Aggressor and the Victim. Unmitigated, this glitch can result in unacceptably higher noise floor after range and doppler processing – hence identifying the region of the glitch (referred to as the process of **localization**), and 'healing' the damage (referred to as **mitigation**) are both vital signal processing steps necessary to preserve the SNR and maintain robust performance.

The AWR294x transceiver is TI's latest radar-on-a-chip which has, in addition to a C66x DSP (for proprietary signal processing) and a R5F Arm processor (tracking, communication, and control, and so forth), a radar signal process hardware accelerator (called the HWA). The HWA is equipped with hardware blocks to localize and mitigate interferers in-line during range processing.

This document discusses two topics, the mechanism of crossing interference and the methods to detect and mitigate such interference using the HWA. A more thorough introduction to FMCW radar interference can be seen in [1].

## 2 Crossing Interference

Crossing interference can only happen if the victim radar and the aggressor radar have chirp designs with different slopes. In such a case, the two chirps can cross each other. When the crossing happens, the victim will observe a transient interference event. The aggressor's transmitted chirp is mixed with victim's chirp and downconverted. The energy of the aggressor is observable to the victim only if their frequency difference falls into victim's IF bandwidth. If the frequency difference is greater, then most of the energy will be filtered out by analog and digital filters. As most of the FMCW radars encountered in the field will have different slopes, and chirp repeat rates, crossing interference is the most likely interference that an FMCW radar will have to face.

An example is given in [Figure 2-1](#). As the aggressor's chirp crosses the victim's transmitted chirp (top plot), the aggressor chirp's energy is observed as a chirp that rapidly moves through the IF bandwidth (second plot). In time domain, the region affected by interference thus resembles a glitch (third plot).

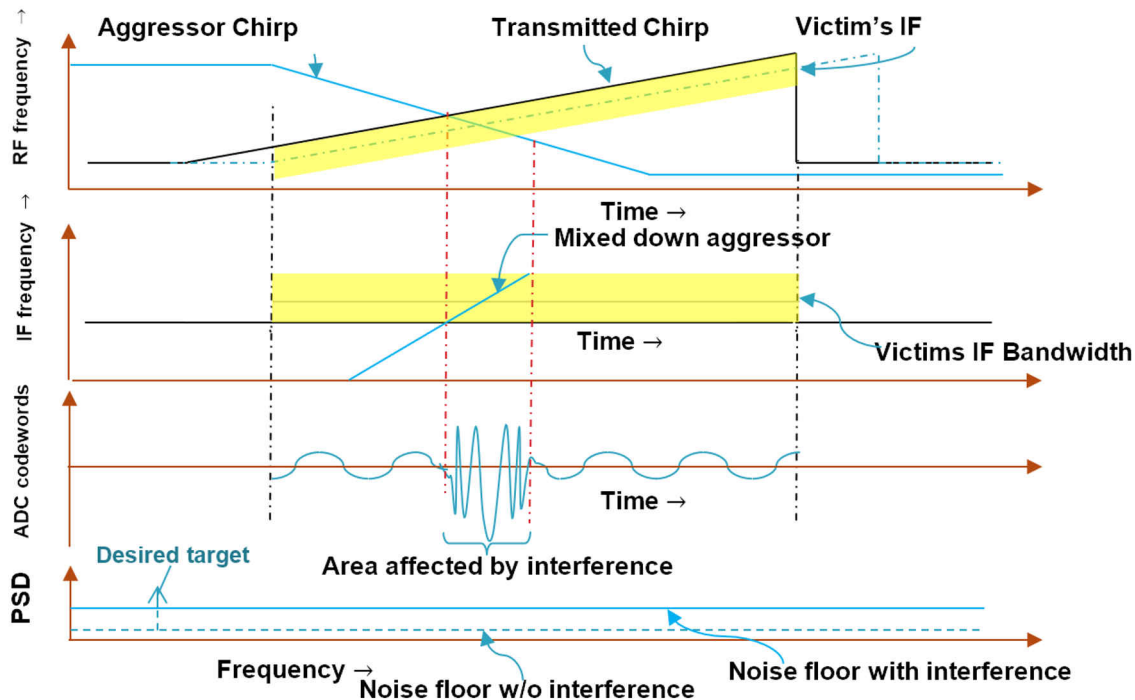

**Figure 2-1. Crossing Interference Causing a Glitch in the Time Domain Signal**

Finally, after a Fourier transform is applied on the ADC samples, in the frequency domain, these crossing interferers typically increase the noise floor and reduce the SNR of strong targets and bury weak targets, thereby affecting detection and creating momentary blind spots. The glitch duration ( $\tau_{Glitch}$ ) is governed by the victim's IF bandwidth and the slopes of the victim ( $slope_{victim}$ ) and the aggressor ( $slope_{aggressor}$ ). It is shown in Equation 1:

$$\tau_{Glitch} = \frac{BandWidth_{IF}}{|slope_{aggressor} - slope_{victim}|} \quad (1)$$

Note that the glitch duration is typically small. For example, if the IF bandwidth is 12 MHz and the difference in slopes is 40 MHz/ $\mu$ s, approximately 0.3  $\mu$ s, or four samples of the final ADC output, would be affected by interference.

## 2.1 Performance Analysis for Crossing Interference

The level of interference would depend on the distance between the radars (R), the antenna gain in the line connecting the Aggressor Tx and the Victim Rx ( $Agg_{txAntGain_{dB}} + Vic_{rxAntGain_{dB}}$ ), the duration of time during which the chirps 'cross' and the Aggressor transmit power ( $P_{Aggtx}$ ).

The main effect of this interference would be to raise the noise floor. The increase of the noise floor after range processing can be calculated as:

$$NoiseInc_{dB} = P_{Interference} + 10 \log_{10} \left( \frac{affectedAdcSamp}{totalNumAdcSamp} \right) - P_{noise} \quad (2)$$

Where  $\frac{affectedAdcSamp}{totalNumAdcSamp}$  is the ratio of the number of ADC samples that were affected by interference to the total number of adc samples.  $P_{noise}$  is the native noise floor without any interference, and is given by the following equation, where  $N_F$  is the Victim Receiver's noise figure, and  $BandWidth_{IF}$  is the IF bandwidth.

$$P_{noise} = -174^\circ + N_F + 10 \log_{10}(BandWidth_{IF}) \quad (3)$$

$P_{Interference}$  is the interference power received at the victim and is given by the following equation:

$$P_{Interference} = P_{Aggtx} + Agg_{txAntGain_{dB}} + Vic_{rxAntGain_{dB}} - 10 \log_{10} \left( \frac{4\pi R}{\lambda} \right)^2 \quad (4)$$

Where  $\lambda$  corresponds to the wavelength.

As an example, assume the following parameters:

- Aggressor power (dBm),  $P_{Aggtx} = 10$  dBm
- Aggressor antenna gain,  $Agg_{txAntGain_{dB}} = 10$  dB
- Victim antenna gain,  $Vic_{rxAntGain_{dB}} = 10$  dB
- Victim Noise Figure,  $N_F = 14$  dB
- IF Bandwidth,  $BandWidth_{IF} = 10$  MHz
- Wavelength,  $\lambda = 3.9$  mm
- Distance between Aggressor and Victim = 10 meters
- Number of samples affected = 10 %

Then,

- Interferer power,  $P_{Interference} = -60$  dBm
- Thermal Noise power,  $P_{noise} = -90$  dBm
- Increase in the noise floor,  $NoiseInc_{dB} = 20$  dB

A 20 dB increase in the noise floor results in missed detections, unless the glitch is located and removed.

### 3 Localization and Mitigation on the Hardware Accelerator (HWA)

With the theory in place, the methods available on devices like the AWR294x for localization and mitigation of interference are discussed. Localization is defined as the process of finding interfered regions in ADC data, while Mitigation refers to the process of healing the damaged region.

The radar hardware accelerator [2] (or HWA) is collection of accelerators for common radar signal processing options. These accelerators are divided into four different cores (Figure 3-1): FFT, CFAR, Compression/Decompression, and Local maxima. The interference modules are part of the FFT Engine – and are placed before the FFT engine. This is so that the process of interference mitigation is performed prior to and inline with the FFT. All modules are streaming engines – every cycle they take in one sample as input and give one sample as output. Hence, the additional cost of interference mitigation is only a few additional cycles.

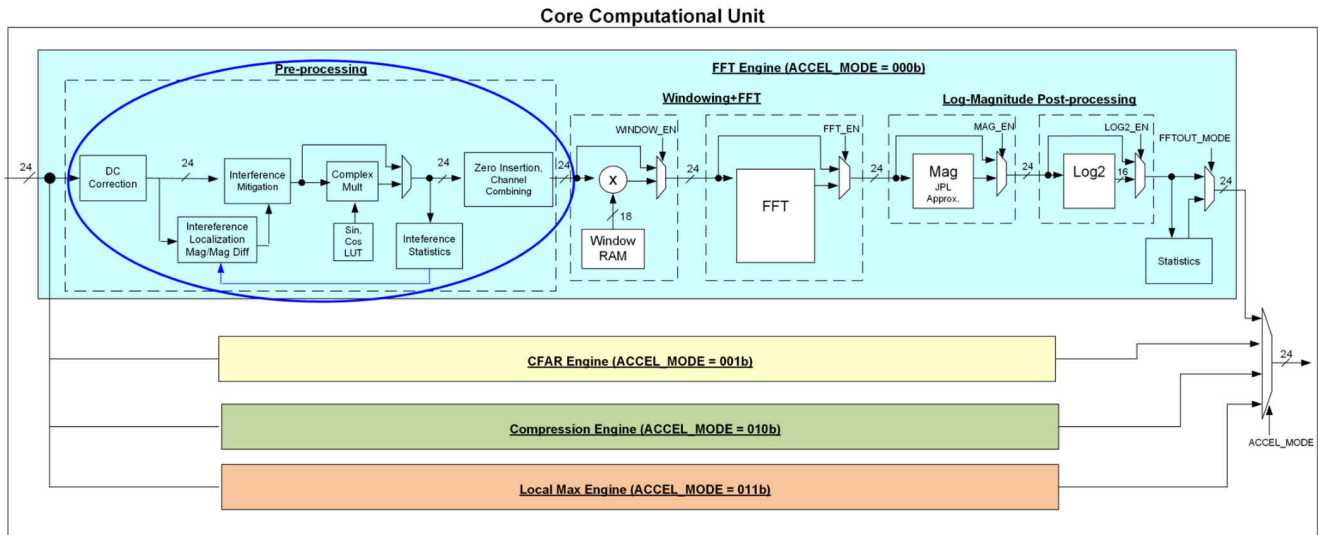

The different interference mitigation modules are seen in the pre-processing section (encircled in blue).

**Figure 3-1. Different Accelerators Available in the HWA**

The modules related to interference are:

- Interference Statistics Module - computes statistics on the ADC data and generates thresholds.
- Interference Localization Module – uses the thresholds to find outliers.
- Interference Mitigation Module - removes outliers using one of three methods.

The process of interference mitigation is a two pass process (Figure 3-2):

1. In the first pass, statistics are computed on the ADC. Interference Localization and Mitigation is a two pass method.
2. In the second pass, the statistics are used to generate thresholds. Then, samples that cross the threshold are marked as corrupted/interfered with in the interference localization module. This information is then provided to the interference mitigation module.

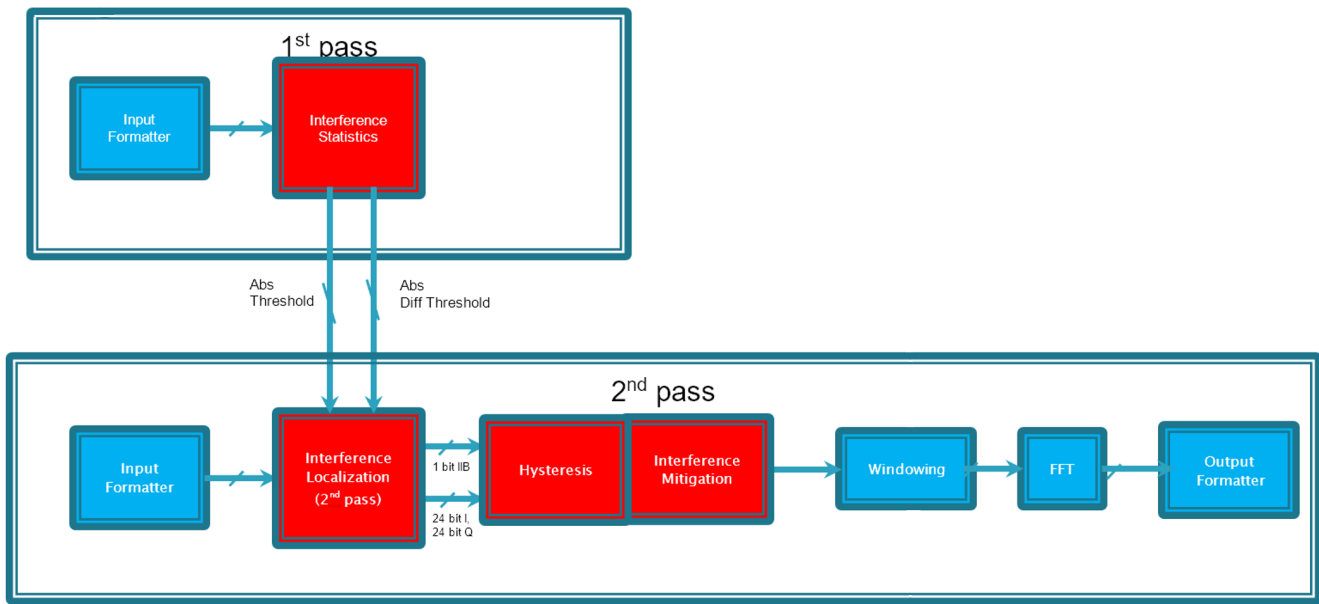

**Figure 3-2. Interference Mitigation Flow**

### 3.1 Interference Statistics

Two kinds of statistics are computed on the ADC data [2]. These are:

- The sum of absolute values of the adc data,  $absSum = \sum_{i=1}^N |x_i|$  where  $x_i$  corresponds to the adc samples in the chirp.
- The sum of the first difference of adc data,  $diffAbsSum = \sum_{i=2}^N |x_i - x_{i-1}|$ .

These are then scaled down to generate means, and then scaled up to generate two thresholds (AbsThreshold and AbsDiffThreshold).

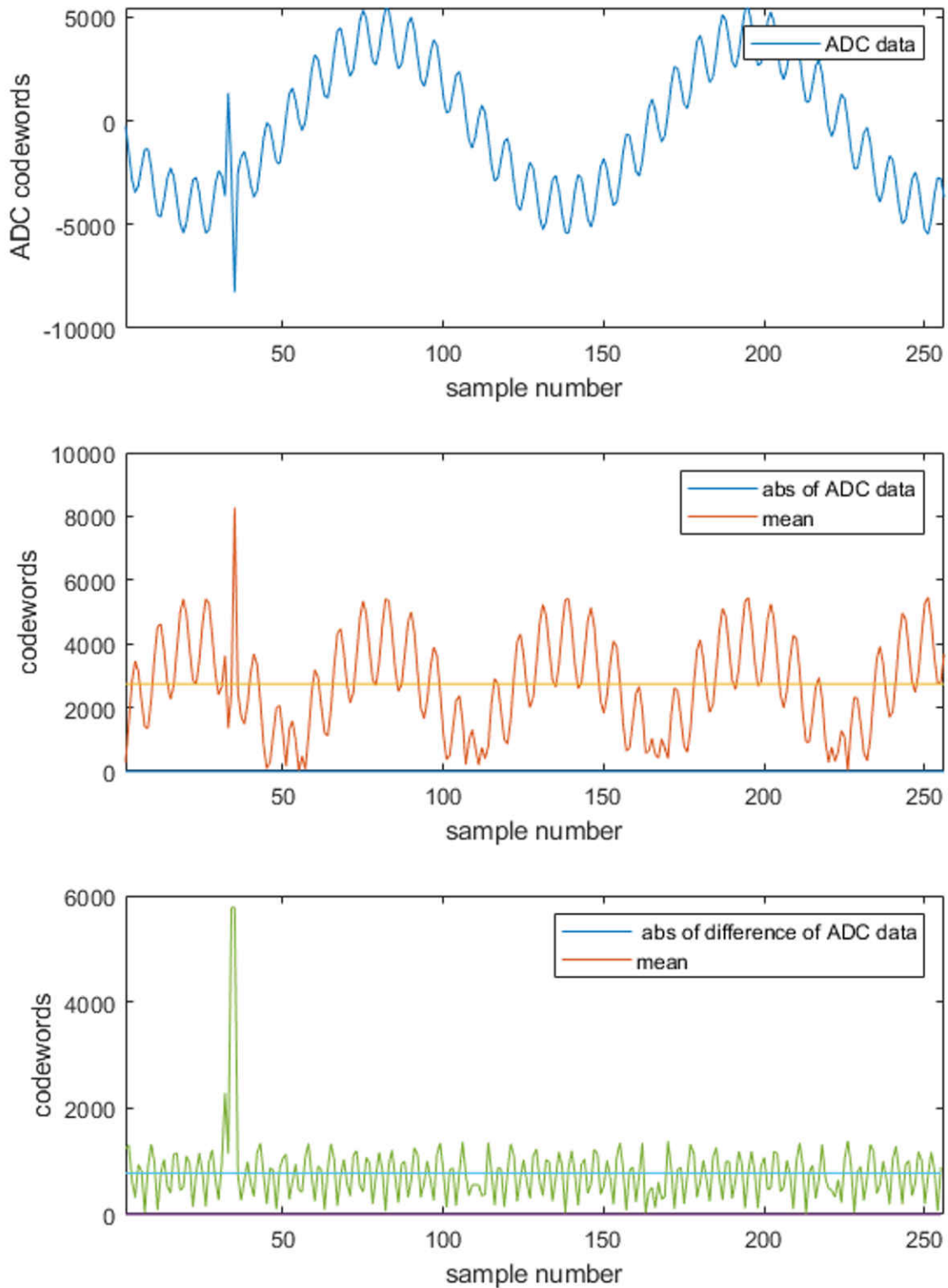

The abs-diff filters suppress the low-frequency tone and help make the glitch more visible.

**Figure 3-3. Detecting Outliers Using Abs and Abs-diff Filters**

The advantage of calculating the first difference is that it suppresses low-frequency reflections like the bumper reflection or the antenna coupling effect, allowing weaker glitches to be easily found.

### 3.2 Localization Module

Localization is performed by finding outliers in ADC data [2]. Using the thresholds set from the interference statistics, these outliers can be found. Samples that cross this threshold in energy can be marked as having been affected by interference. Note that options are available to use either the 'absThreshold' and/or the 'absDiffThreshold' to detect the outliers.

In the 2944, each sample is marked by an interference indicator bit (or IIB), which is zero if below threshold and 1 if it is above. This sequence can then be provided to a Hysteresis module which optionally provides hysteresis. Finally this IIB bitstream is sent to the mitigation module, where it is used to identify interferer locations.

### 3.3 Mitigation

A number of mitigation methods are available in the HWA 2.0 [2]. The simplest method of mitigation is to replace the region of interference with zeros (Figure 3-4 - top). However, that has the side effect of creating large sidelobes that might bury weak targets. A better approach is to blank out with a window. A smoothing window is used to zero the samples that have been affected by interference. This leads to lower sidelobes and better detectability of weak targets (Figure 3-4 - middle).

An even better approach would be to perform linear interpolation in the blank region, using the last good ADC sample before interference and the first good ADC sample after the period of interference. Since the strongest reflectors are likely to be closer to the radar and hence have lower frequencies, this approach works well in many cases (Figure 3-4 - bottom).

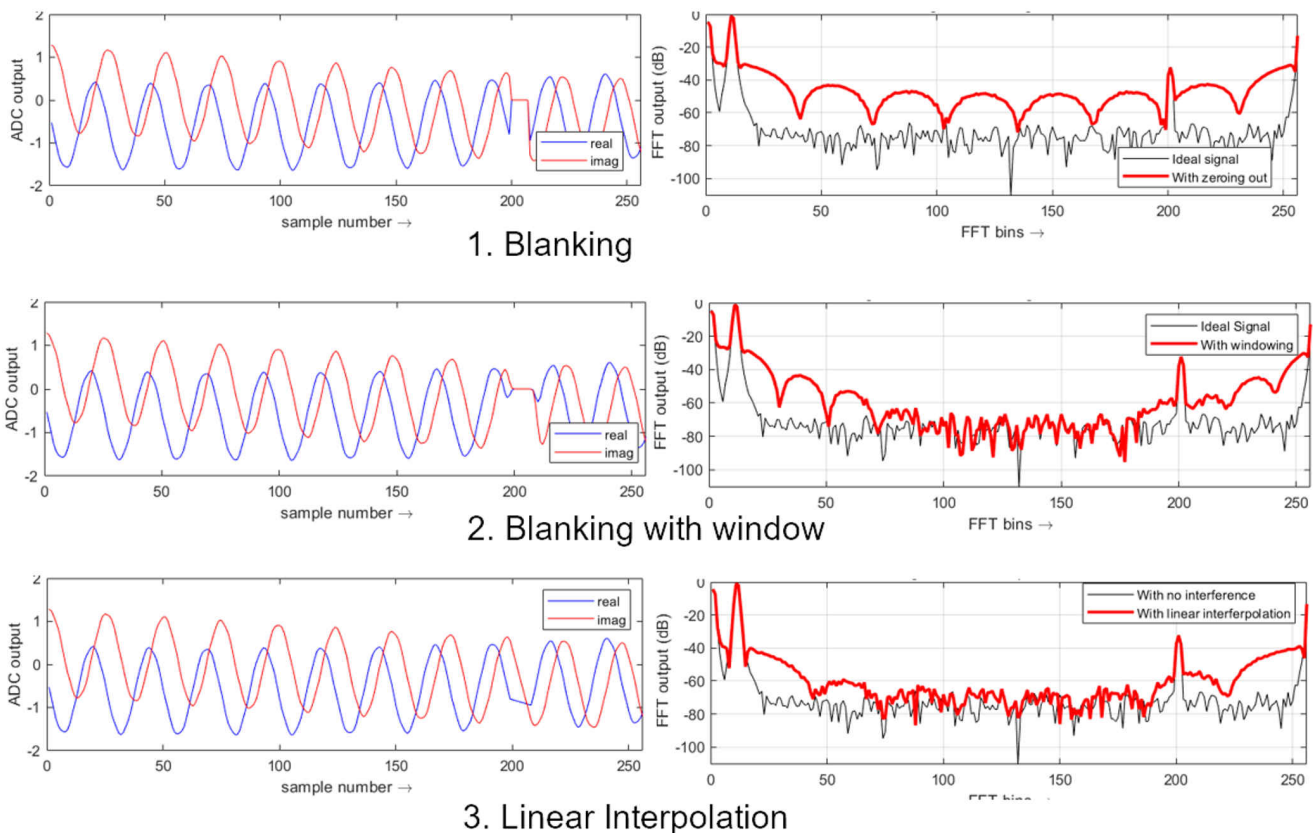

Figure 3-4. Different Mitigation Approaches

Mitigation is an active area of research and more complex mitigation schemes that are possible than the three we've discussed. However, as the mitigation scheme becomes more complex, one has to weigh the amount of MIPs consumed against the benefit gained by the more complex scheme.



## 4 Summary

Crossing interference can lead to detection failures due to an unacceptable increase in the processed signals noise floor. In ADC data, these interference events look like glitches. Localizing and mitigating these glitches is vital to maintain robust radar performance.

The AWR294x transceiver has multiple tools to find and localize interference, including specialized modules in the radar signal processing to allow inline removal of these interferers.

## 5 References

1. Sriram Murali, Karthik Subburaj, Brian Ginsburg and Karthik Ramasubramanian, “[Interference Detection in FMCW Radar Using A Complex Baseband Oversampled Receiver](#)”
2. Texas Instruments: [AWR294x Technical Reference Manual v0.7 Technical Reference Manual](#)

## IMPORTANT NOTICE AND DISCLAIMER

TI PROVIDES TECHNICAL AND RELIABILITY DATA (INCLUDING DATA SHEETS), DESIGN RESOURCES (INCLUDING REFERENCE DESIGNS), APPLICATION OR OTHER DESIGN ADVICE, WEB TOOLS, SAFETY INFORMATION, AND OTHER RESOURCES "AS IS" AND WITH ALL FAULTS, AND DISCLAIMS ALL WARRANTIES, EXPRESS AND IMPLIED, INCLUDING WITHOUT LIMITATION ANY IMPLIED WARRANTIES OF MERCHANTABILITY, FITNESS FOR A PARTICULAR PURPOSE OR NON-INFRINGEMENT OF THIRD PARTY INTELLECTUAL PROPERTY RIGHTS.

These resources are intended for skilled developers designing with TI products. You are solely responsible for (1) selecting the appropriate TI products for your application, (2) designing, validating and testing your application, and (3) ensuring your application meets applicable standards, and any other safety, security, regulatory or other requirements.

These resources are subject to change without notice. TI grants you permission to use these resources only for development of an application that uses the TI products described in the resource. Other reproduction and display of these resources is prohibited. No license is granted to any other TI intellectual property right or to any third party intellectual property right. TI disclaims responsibility for, and you will fully indemnify TI and its representatives against, any claims, damages, costs, losses, and liabilities arising out of your use of these resources.

TI's products are provided subject to [TI's Terms of Sale](#) or other applicable terms available either on [ti.com](http://ti.com) or provided in conjunction with such TI products. TI's provision of these resources does not expand or otherwise alter TI's applicable warranties or warranty disclaimers for TI products.

TI objects to and rejects any additional or different terms you may have proposed.

Mailing Address: Texas Instruments, Post Office Box 655303, Dallas, Texas 75265  
Copyright © 2022, Texas Instruments Incorporated