

ADC10731/ADC10732/ADC10734/ADC10738 10-Bit Plus Sign Serial I/O A/D Converters with Mux, Sample/Hold and Reference

Check for Samples: [ADC10731](#), [ADC10732](#), [ADC10734](#), [ADC10738](#)

FEATURES

- 0V to Analog Supply Input Range
- Serial I/O (MICROWIRE Compatible)
- Software or Hardware Power Down
- Analog Input Sample/Hold Function
- Ratiometric or Absolute Voltage Referencing
- No Zero or Full Scale Adjustment Required
- No Missing Codes Over Temperature
- TTL/CMOS Input/Output Compatible

APPLICATIONS

- Medical Instruments
- Portable and Remote Instrumentation
- Test Equipment

KEY SPECIFICATIONS

- Resolution 10 Bits Plus Sign
- Single Supply 5 V
- Power Consumption 37 mW (Max)
- In Power Down Mode 18 μ W
- Conversion Time 5 μ s (Max)
- Sampling Rate 74 kHz (Max)
- Band-Gap Reference 2.5V \pm 2% (Max)

DESCRIPTION

The ADC10731, ADC10732 and ADC10734 are obsolete or on lifetime buy and included for reference only.

This series of CMOS 10-bit plus sign successive approximation A/D converters features versatile analog input multiplexers, sample/hold and a 2.5V band-gap reference. The 1-, 2-, 4-, or 8-channel multiplexers can be software configured for single-ended or differential mode of operation.

An input sample/hold is implemented by a capacitive reference ladder and sampled-data comparator. This allows the analog input to vary during the A/D conversion cycle.

In the differential mode, valid outputs are obtained even when the negative inputs are greater than the positive because of the 10-bit plus sign output data format.

The serial I/O is configured to comply with the MICROWIRE serial data exchange standard for easy interface to the COPS and HPC families of controllers, and can easily interface with standard shift registers and microprocessors.



Please be aware that an important notice concerning availability, standard warranty, and use in critical applications of Texas Instruments semiconductor products and disclaimers thereto appears at the end of this data sheet.

All trademarks are the property of their respective owners.

ADC10738 Simplified Block Diagram

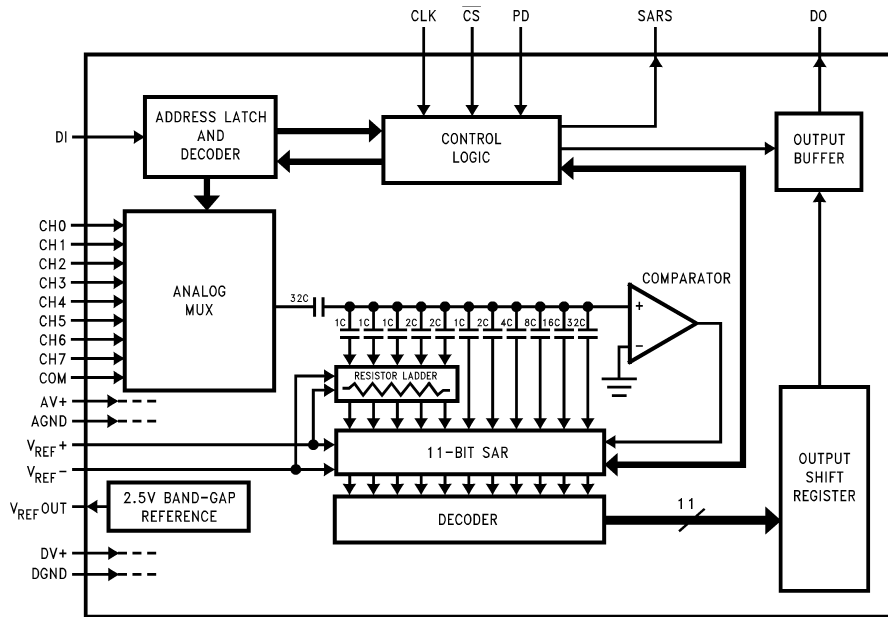

Connection Diagrams

The ADC10731, ADC10732 and ADC10734 are obsolete in all packages. They are in this data sheet for reference only.

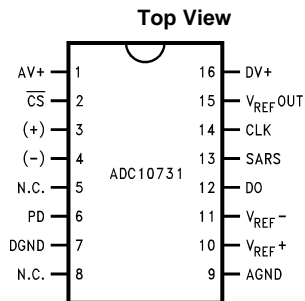

Figure 1. ADC10731 16-Pin SOIC Package
See Package Number DW0016B

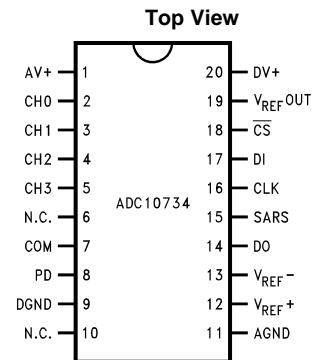

Figure 2. ADC10734 20-Pin SOIC Package
See Package Number DW0020B

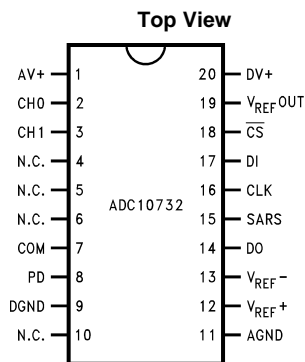

Figure 3. ADC10732 20-Pin SOIC Package
See Package Number DW0020B

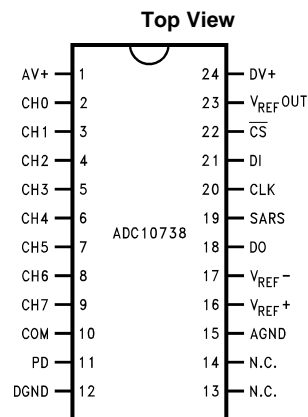

Figure 4. ADC10738 24-Pin SOIC Package
See Package Number DW0024B

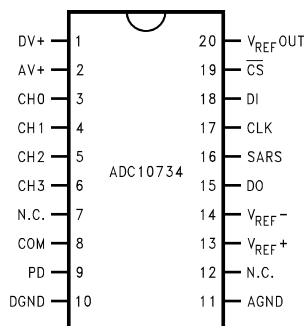

Figure 5. SSOP Package
See Package Number DB0020A

Table 1. Pin Descriptions

Pin Name	Description
CLK	The clock applied to this input controls the successive approximation conversion time interval, the acquisition time and the rate at which the serial data exchange occurs. The rising edge loads the information on the DI pin into the multiplexer address shift register. This address controls which channel of the analog input multiplexer (MUX) is selected. The falling edge shifts the data resulting from the A/D conversion out on DO. \overline{CS} enables or disables the above functions. The clock frequency applied to this input can be between 5 kHz and 3 MHz
DI	This is the serial data input pin. The data applied to this pin is shifted by CLK into the multiplexer address register. Table 2, Table 3, Table 4 show the multiplexer address assignment.
DO	The data output pin. The A/D conversion result (DB0-SIGN) are clocked out by the falling edge of CLK on this pin.
\overline{CS}	This is the chip select input pin. When a logic low is applied to this pin, the rising edge of CLK shifts the data on DI into the address register. This low also brings DO out of TRI-STATE after a conversion has been completed
PD	This is the power down input pin. When a logic high is applied to this pin the A/D is powered down. When a low is applied the A/D is powered up.
SARS	This is the successive approximation register status output pin. When \overline{CS} is high this pin is in TRI-STATE. With \overline{CS} low this pin is active high when a conversion is in progress and active low at all other times.
CH0-CH7	These are the analog inputs of the MUX. A channel input is selected by the address information at the DI pin, which is loaded on the rising edge of CLK into the address register (see Table 2, Table 3, Table 4). The voltage applied to these inputs should not exceed AV ⁺ or go below GND by more than 50 mV. Exceeding this range on an unselected channel will corrupt the reading of a selected channel.

Table 1. Pin Descriptions (continued)

Pin Name	Description
COM	This pin is another analog input pin. It can be used as a “pseudo ground” when the analog multiplexer is single-ended.
V _{REF+}	This is the positive analog voltage reference input. In order to maintain accuracy, the voltage range V _{REF} (V _{REF} = V _{REF+} –V _{REF-}) is 0.5 V _{DC} to 5.0 V _{DC} and the voltage at V _{REF+} cannot exceed AV ⁺ +50 mV.
V _{REF-}	The negative voltage reference input. In order to maintain accuracy, the voltage at this pin must not go below GND – 50 mV or exceed AV ⁺ + 50 mV.
AV ⁺ , DV ⁺	These are the analog and digital power supply pins. These pins should be tied to the same power supply and bypassed separately. The operating voltage range of AV ⁺ and DV ⁺ is 4.5 V _{DC} to 5.5 V _{DC} .
DGND	This is the digital ground pin.
AGND	This is the analog ground pin.



These devices have limited built-in ESD protection. The leads should be shorted together or the device placed in conductive foam during storage or handling to prevent electrostatic damage to the MOS gates.

Absolute Maximum Ratings⁽¹⁾⁽²⁾⁽³⁾

Supply Voltage (V ⁺ = AV ⁺ = DV ⁺)	6.5V		
Total Reference Voltage (V _{REF+} –V _{REF-})	6.5V		
Voltage at Inputs and Outputs	V ⁺ + 0.3V to –0.3V		
Input Current at Any Pin ⁽⁴⁾	30 mA		
Package Input Current ⁽⁴⁾	120 mA		
Package Dissipation at T _A = 25°C ⁽⁵⁾	500 mW		
ESD Susceptibility ⁽⁶⁾	Human Body Model	2500V	
	Machine Model	150V	
Soldering Information	N packages (10 seconds)	260°C	
	SOIC Package	Vapor Phase (60 seconds)	215°C
		Infrared (15 seconds)	220°C
Storage Temperature	–40°C to +150°C		

- (1) All voltages are measured with respect to GND, unless otherwise specified.
- (2) Absolute Maximum Ratings indicate limits beyond which damage to the device may occur.
- (3) If Military/Aerospace specified devices are required, please contact the Texas Instruments Sales Office/ Distributors for availability and specifications.
- (4) When the input voltage (V_{IN}) at any pin exceeds the power supplies (V_{IN} < GND or V_{IN} > AV⁺ or DV⁺), the current at that pin should be limited to 30 mA. The 120 mA maximum package input current rating limits the number of pins that can safely exceed the power supplies with an input current of 30 mA to four.
- (5) The maximum power dissipation must be derated at elevated temperatures and is dictated by T_{Jmax}, θ_{JA} and the ambient temperature, T_A. The maximum allowable power dissipation at any temperature is P_D = (T_{Jmax} – T_A)/θ_{JA} or the number given in the Absolute Maximum Ratings, whichever is lower. For this device, T_{Jmax} = 150°C. The typical thermal resistance (θ_{JA}) of these Paris when board mounted can be found in the following [Power Dissipation](#) table:
- (6) The human body model is a 100 pF capacitor discharged through a 1.5 kΩ resistor into each pin. The machine model is a 200 pF capacitor discharged directly into each pin.

Operating Ratings⁽¹⁾⁽²⁾

Operating Temperature Range	T _{MIN} ≤ T _A ≤ T _{MAX}	–40°C ≤ T _A ≤ +85°C
Supply Voltage (V ⁺ = AV ⁺ = DV ⁺)		+4.5V to +5.5V
V _{REF+}		AV ⁺ +50 mV to –50 mV
V _{REF-}		AV ⁺ +50 mV to –50 mV
V _{REF} (V _{REF+} –V _{REF-})		+0.5V to V ⁺

- (1) Operating Ratings indicate conditions for which the device is functional, but do not ensure specific performance limits. For ensured specifications and test conditions, see the Electrical Characteristics table. The ensured specifications apply only for the test conditions listed. Some performance characteristics may degrade when the device is not operated under the listed test conditions.
- (2) All voltages are measured with respect to GND, unless otherwise specified.

Electrical Characteristics

The following specifications apply for $V^+ = AV^+ = DV^+ = +5.0 V_{DC}$, $V_{REF+} = 2.5 V_{DC}$, $V_{REF-} = GND$, $V_{IN-} = 2.5V$ for Signed Characteristics, $V_{IN-} = GND$ for Unsigned Characteristics and $f_{CLK} = 2.5 MHz$ unless otherwise specified. **Boldface limits apply for $T_A = T_J = T_{MIN}$ to T_{MAX} ; all other limits $T_A = T_J = +25^\circ C$.** ⁽¹⁾⁽²⁾⁽³⁾⁽⁴⁾

Parameter		Test Conditions	Typ ⁽⁵⁾	Limits ⁽⁶⁾	Units (Limits)	
SIGNED STATIC CONVERTER CHARACTERISTICS						
	Resolution with No Missing Codes			10 + Sign	Bits	
TUE	Total Unadjusted Error ⁽⁷⁾			±2.0	LSB (max)	
INL	Positive and Negative Integral Linearity Error			±1.25	LSB (max)	
	Positive and Negative Full-Scale Error			±1.5	LSB (max)	
	Offset Error			±1.5	LSB (max)	
	Power Supply Sensitivity	Offset Error	$V^+ = +5.0V \pm 10\%$	±0.2	±1.0	LSB (max)
		+ Full-Scale Error		±0.2	±1.0	LSB (max)
		- Full-Scale Error		±0.1	±0.75	LSB (max)
	DC Common Mode Error ⁽⁸⁾	$V_{IN+} = V_{IN-} = V_{IN}$ where $5.0V \geq V_{IN} \geq 0V$	±0.1	±0.33	LSB (max)	
	Multiplexer Chan to Chan Matching		±0.1		LSB	
UNSIGNED STATIC CONVERTER CHARACTERISTICS						
	Resolution with No Missing Codes			10	Bits	
TUE	Total Unadjusted Error ⁽⁷⁾	$V_{REF+} = 4.096V$	±0.75		LSB	
INL	Integral Linearity Error	$V_{REF+} = 4.096V$	±0.50		LSB	
	Full-Scale Error	$V_{REF+} = 4.096V$		±1.25	LSB (max)	
	Offset Error	$V_{REF+} = 4.096V$		±1.25	LSB (max)	
	Power Supply Sensitivity	Offset Error	$V^+ = +5.0V \pm 10\%$	±0.1	LSB	
		Full-Scale Error		$V_{REF+} = 4.096V$	±0.1	LSB
	DC Common Mode Error ⁽⁸⁾	$V_{IN+} = V_{IN-} = V_{IN}$ where $+5.0V \geq V_{IN} \geq 0V$	±0.1		LSB	
	Multiplexer Channel to Channel Matching	$V_{REF+} = 4.096V$	±0.1		LSB	
DYNAMIC SIGNED CONVERTER CHARACTERISTICS						
S/(N+D)	Signal-to-Noise Plus Distortion Ratio	$V_{IN} = 4.85 V_{PP}$, and $f_{IN} = 1 kHz$ to $15 kHz$	67		dB	
ENOB	Effective Number of Bits	$V_{IN} = 4.85 V_{PP}$, and $f_{IN} = 1 kHz$ to $15 kHz$	10.8		Bits	
THD	Total Harmonic Distortion	$V_{IN} = 4.85 V_{PP}$, and $f_{IN} = 1 kHz$ to $15 kHz$	-78		dB	
IMD	Intermodulation Distortion	$V_{IN} = 4.85 V_{PP}$, and $f_{IN} = 1 kHz$ to $15 kHz$	-85		dB	
	Full-Power Bandwidth	$V_{IN} = 4.85 V_{PP}$, where S/(N + D) Decreases 3 dB	380		kHz	
	Multiplexer Chan to Chan Crosstalk	$f_{IN} = 15 kHz$	-80		dB	

- Two on-chip diodes are tied to each analog input as shown below. They will forward-conduct for analog input voltages one diode drop below ground or one diode drop greater than V^+ supply. Be careful during testing at low V^+ levels (+4.5V), as high level analog inputs (+5V) can cause an input diode to conduct, especially at elevated temperatures, which will cause errors in the conversion result. The specification allows 50 mV forward bias of either diode; this means that as long as the analog V_{IN} does not exceed the supply voltage by more than 50 mV, the output code will be correct. Exceeding this range on an unselected channel will corrupt the reading of a selected channel. If AV^+ and DV^+ are minimum ($4.5 V_{DC}$) and full scale must be $\leq 4.55 V_{DC}$. See [Figure 6](#)
- No connection exists between AV^+ and DV^+ on the chip. To ensure accuracy, it is required that the AV^+ and DV^+ be connected together to a power supply with separate bypass filter at each V^+ pin.
- One LSB is referenced to 10 bits of resolution.
- All the timing specifications are tested at the TTL logic levels, $V_{IL} = 0.8V$ for a falling edge and $V_{IH} = 2.0V$ for a rising. TRI-STATE voltage level is forced to 1.4V.
- Typicals are at $T_J = T_A = 25^\circ C$ and represent most likely parametric norm.
- Tested limits are ensured to AOQL (Average Outgoing Quality Level).
- Total unadjusted error includes offset, full-scale, linearity, multiplexer, and hold step errors.
- The DC common-mode error is measured in the differential multiplexer mode with the assigned positive and negative input channels shorted together.

Electrical Characteristics (continued)

The following specifications apply for $V^+ = AV^+ = DV^+ = +5.0 V_{DC}$, $V_{REF+} = 2.5 V_{DC}$, $V_{REF-} = GND$, $V_{IN-} = 2.5V$ for Signed Characteristics, $V_{IN-} = GND$ for Unsigned Characteristics and $f_{CLK} = 2.5 MHz$ unless otherwise specified. **Boldface limits apply for $T_A = T_J = T_{MIN}$ to T_{MAX} ; all other limits $T_A = T_J = +25^{\circ}C$.**⁽¹⁾⁽²⁾⁽³⁾⁽⁴⁾

Parameter	Test Conditions	Typ ⁽⁵⁾	Limits ⁽⁶⁾	Units (Limits)
DYNAMIC UNSIGNED CONVERTER CHARACTERISTIC				
S/(N+D)	Signal-to-Noise Plus Distortion Ratio	$V_{REF+} = 4.096V$, $V_{IN} = 4.0 V_{PP}$, and $f_{IN} = 1 kHz$ to 15 kHz	60	dB
ENOB	Effective Bits	$V_{REF+} = 4.096V$, $V_{IN} = 4.0 V_{PP}$, and $f_{IN} = 1 kHz$ to 15 kHz	9.8	Bits
THD	Total Harmonic Distortion	$V_{REF+} = 4.096V$, $V_{IN} = 4.0 V_{PP}$, and $f_{IN} = 1 kHz$ to 15 kHz	-70	dB
IMD	Intermodulation Distortion	$V_{REF+} = 4.096V$, $V_{IN} = 4.0 V_{PP}$, and $f_{IN} = 1 kHz$ to 15 kHz	-73	dB
	Full-Power Bandwidth	$V_{IN} = 4.0 V_{PP}$, $V_{REF+} = 4.096V$, where S/(N+D) decreases 3 dB	380	kHz
	Multiplexer Chan to Chan Crosstalk	$f_{IN} = 15 kHz$, $V_{REF+} = 4.096V$	-80	dB
REFERENCE INPUT AND MULTIPLEXER CHARACTERISTICS				
	Reference Input Resistance		7	kΩ
			5.0	kΩ(min)
			9.5	kΩ(max)
C _{REF}	Reference Input Capacitance		70	pF
	MUX Input Voltage		-50 AV⁺ + 50mV	mV (min) (max)
C _{IM}	MUX Input Capacitance		47	pF
	Off Channel Leakage Current ⁽⁹⁾	On Channel = 5V and Off Channel = 0V	-0.4	-3.0 μA (max)
		On Channel = 0V and Off Channel = 5V	0.4	3.0 μA (max)
	On Channel Leakage Current ⁽⁹⁾	On Channel = 5V and Off Channel = 0V	0.4	3.0 μA (max)
		On Channel = 0V and Off Channel = 5V	-0.4	-3.0 μA (max)
REFERENCE CHARACTERISTICS				
V _{REFOut}	Reference Output Voltage		2.5V ±0.5%	2.5V ±2% V (max)
$\Delta V_{REF}/\Delta T$	V _{REFOut} Temperature Coefficient		±40	ppm/°C
$\Delta V_{REF}/\Delta I_L$	Load Regulation, Sourcing	0 mA ≤ I _L ≤ +4 mA	±0.003	±0.05 %/mA (max)
$\Delta V_{REF}/\Delta I_L$	Load Regulation, Sinking	0 mA ≤ I _L ≤ -1 mA	±0.2	±0.6 %/mA (max)
	Line Regulation	5V ±10%	±0.3	±2.5 mV (max)
I _{SC}	Short Circuit Current	V _{REFOut} = 0V	13	22 mA (max)
	Noise Voltage	10 Hz to 10 kHz, C _L = 100 μF	5	μV
$\Delta V_{REF}/\Delta t$	Long-term Stability		±120	ppm/kHr
t _{SU}	Start-Up Time	C _L = 100 μF	100	ms

(9) Channel leakage current is measured after the channel selection.

Electrical Characteristics (continued)

The following specifications apply for $V^+ = AV^+ = DV^+ = +5.0 V_{DC}$, $V_{REF+} = 2.5 V_{DC}$, $V_{REF-} = GND$, $V_{IN-} = 2.5V$ for Signed Characteristics, $V_{IN-} = GND$ for Unsigned Characteristics and $f_{CLK} = 2.5$ MHz unless otherwise specified. **Boldface limits apply for $T_A = T_J = T_{MIN}$ to T_{MAX} ; all other limits $T_A = T_J = +25^\circ C$.**⁽¹⁾⁽²⁾⁽³⁾⁽⁴⁾

Parameter		Test Conditions	Typ ⁽⁵⁾	Limits ⁽⁶⁾	Units (Limits)
DIGITAL AND DC CHARACTERISTICS					
$V_{IN(1)}$	Logical "1" Input Voltage	$V^+ = 5.5V$		2.0	V (min)
$V_{IN(0)}$	Logical "0" Input Voltage	$V^+ = 4.5V$		0.8	V (max)
$I_{IN(1)}$	Logical "1" Input Current	$V_{IN} = 5.0V$	0.005	+2.5	μA (max)
$I_{IN(0)}$	Logical "0" Input Current	$V_{IN} = 0V$	-0.005	-2.5	μA (max)
$V_{OUT(1)}$	Logical "1" Output Voltage	$V^+ = 4.5V, I_{OUT} = -360 \mu A$		2.4	V (min)
		$V^+ = 4.5V, I_{OUT} = -10 \mu A$		4.5	V (min)
$V_{OUT(0)}$	Logical "0" Output Voltage	$V^+ = 4.5V, I_{OUT} = 1.6$ mA		0.4	V (min)
I_{OUT}	TRI-STATE Output Current	$V_{OUT} = 0V$	-0.1	-3.0	μA (max)
		$V_{OUT} = 5V$	+0.1	+3.0	μA (max)
$+I_{SC}$	Output Short Circuit Source Current	$V_{OUT} = 0V, V^+ = 4.5V$	-30	-15	mA(min)
$-I_{SC}$	Output Short Circuit Sink Current	$V_{OUT} = V^+ = 4.5V$	30	15	mA (min)
I_{D+}	Digital Supply Current ⁽¹⁰⁾	$\overline{CS} = HIGH, Power Up$	0.9	1.3	mA (max)
		$\overline{CS} = HIGH, Power Down$	0.2	0.4	mA (max)
		$\overline{CS} = HIGH, Power Down, and CLK Off$	0.5	50	μA (max)
I_{A+}	Analog Supply Current ⁽¹⁰⁾	$\overline{CS} = HIGH, Power Up$	2.7	6.0	mA (max)
		$\overline{CS} = HIGH, Power Down$	3	15	μA (max)
I_{REF}	Reference Input Current	$V_{REF+} = +2.5V$ and $\overline{CS} = HIGH, Power Up$		0.6	mA (max)
AC CHARACTERISTICS					
f_{CLK}	Clock Frequency		3.0 5	2.5	MHz (max) kHz (min)
				40 60	%(min) %(max)
t_C	Conversion Time		12	12	Clock Cycles
			5	5	μs (max)
t_A	Acquisition Time		4.5	4.5	Clock Cycles
			2	2	μs (max)
t_{SCS}	\overline{CS} Set-Up Time, Set-Up Time from Falling Edge of CS to Rising Edge of Clock		14	30	ns (min)
			(1 t_{CLK} - 14 ns)	(1 t_{CLK} - 30 ns)	(max)
t_{SDI}	DI Set-Up Time, Set-Up Time from Data Valid on DI to Rising Edge of Clock		16	25	ns (min)
t_{HDI}	DI Hold Time, Hold Time of DI Data from Rising Edge of Clock to Data not Valid on DI		2	25	ns (min)
t_{AT}	DO Access Time from Rising Edge of CLK When \overline{CS} is "Low" during a Conversion		30	50	ns (min)
t_{AC}	DO or SARS Access Time from \overline{CS} , Delay from Falling Edge of \overline{CS} to Data Valid on DO or SARS		30	70	ns (max)
t_{DSARS}	Delay from Rising Edge of Clock to Falling Edge of SARS when \overline{CS} is "Low"		100	200	ns (max)

(10) The voltage applied to the digital inputs will affect the current drain during power down. These devices are tested with CMOS logic levels (logic Low = 0V and logic High = 5V). TTL levels increase the current, during power down, to about 300 μA .

Electrical Characteristics (continued)

The following specifications apply for $V^+ = AV^+ = DV^+ = +5.0 V_{DC}$, $V_{REF^+} = 2.5 V_{DC}$, $V_{REF^-} = GND$, $V_{IN^-} = 2.5V$ for Signed Characteristics, $V_{IN^-} = GND$ for Unsigned Characteristics and $f_{CLK} = 2.5 MHz$ unless otherwise specified. **Boldface limits apply for $T_A = T_J = T_{MIN}$ to T_{MAX} ; all other limits $T_A = T_J = +25^\circ C$.**⁽¹⁾⁽²⁾⁽³⁾⁽⁴⁾

Parameter		Test Conditions	Typ ⁽⁵⁾	Limits ⁽⁶⁾	Units (Limits)
t_{HDO}	DO Hold Time, Hold Time of Data on DO after Falling Edge of Clock		20	35	ns (max)
t_{AD}	DO Access Time from Clock, Delay from Falling Edge of Clock to Valid Data of DO		40	80	ns (max)
t_{1H}, t_{0H}	Delay from Rising Edge of \overline{CS} to DO or SARS TRI-STATE		40	50	ns (max)
t_{DCS}	Delay from Falling Edge of Clock to Falling Edge of \overline{CS}		20	30	ns (min)
$t_{CS(H)}$	\overline{CS} "HIGH" Time for A/D Reset after Reading of Conversion Result		1 CLK	1 CLK	cycle (min)
$t_{CS(L)}$	ADC10731 Minimum \overline{CS} "Low" Time to Start a Conversion		1 CLK	1 CLK	cycle (min)
t_{SC}	Time from End of Conversion to \overline{CS} Going "Low"		5 CLK	5 CLK	cycle (min)
t_{PD}	Delay from Power-Down command to 10% of Operating Current		1		μs
t_{PC}	Delay from Power-Up Command to Ready to Start a New Conversion		10		μs
C_{IN}	Capacitance of Logic Inputs		7		pF
C_{OUT}	Capacitance of Logic Outputs		12		pF

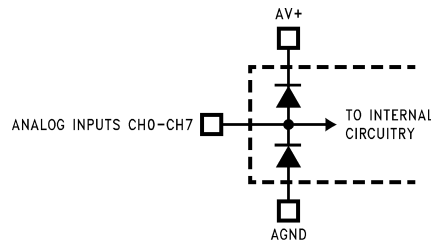

Figure 6.

Power Dissipation

Part Number	Thermal Resistance	Package Type
ADC10731CIWM	90°C/W	M16B
ADC10732CIWM	80°C/W	M20B
ADC10734CIMS	134°C/W	MSA20
ADC10734CIWM	80°C/W	M20B
ADC10738CIWM	75°C/W	M24B

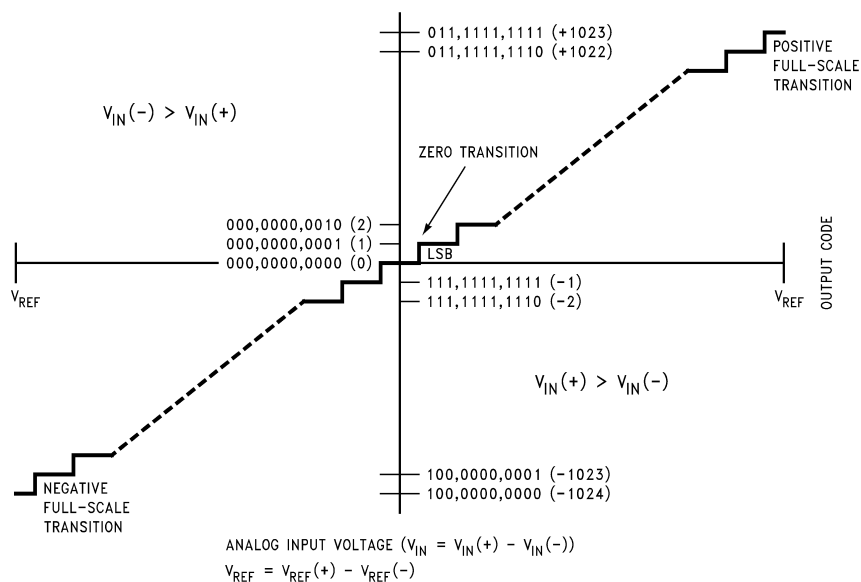

Figure 7. Transfer Characteristics

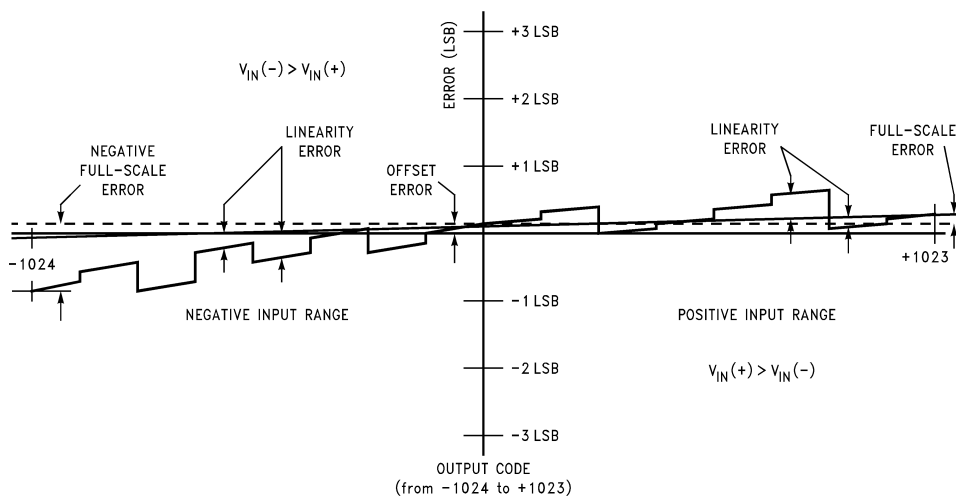

Figure 8. Simplified Error Curve vs Output Code

Test Circuit

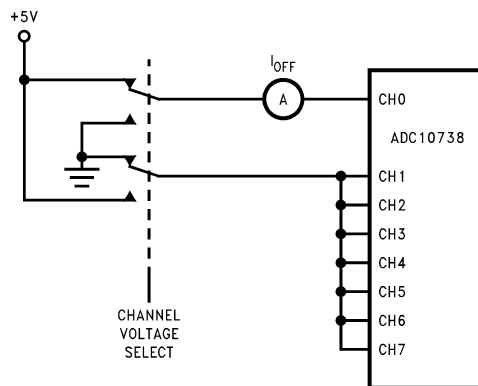

Figure 9. Leakage Current Test Circuit

Typical Performance Characteristics

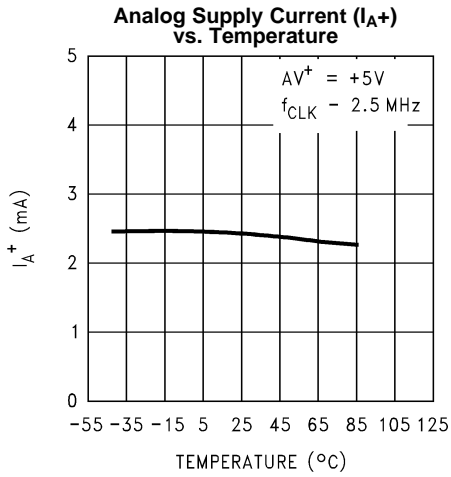

Figure 10.

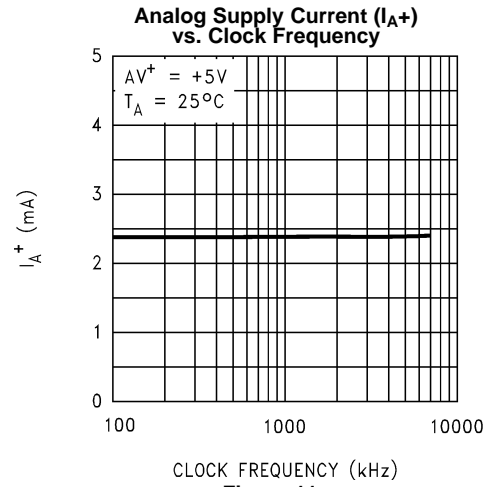

Figure 11.

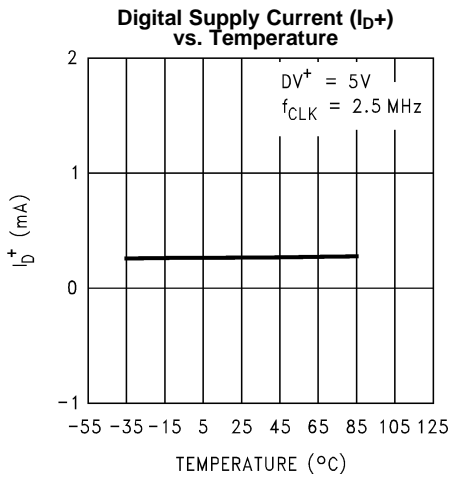

Figure 12.

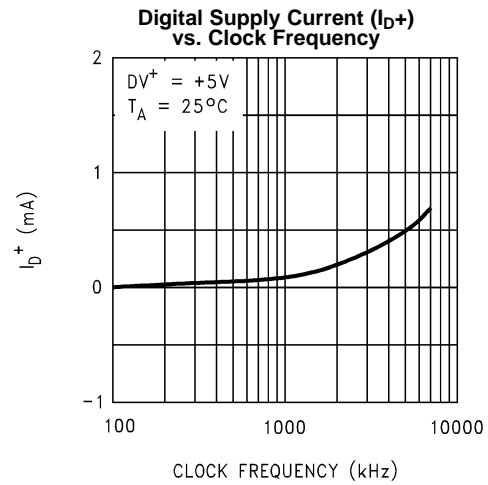

Figure 13.

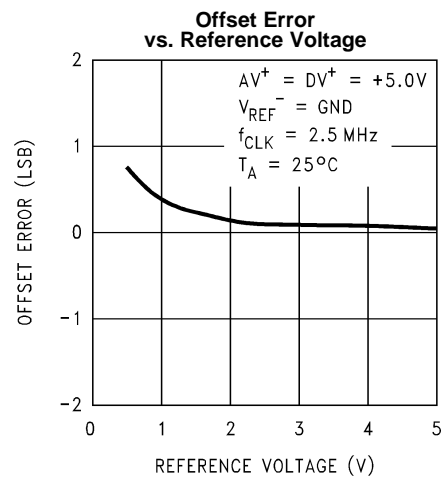

Figure 14.

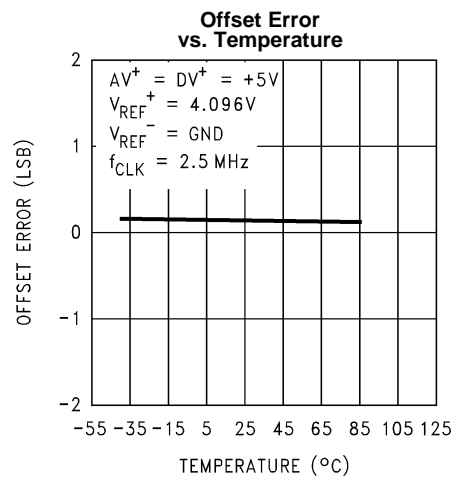

Figure 15.

Typical Performance Characteristics (continued)

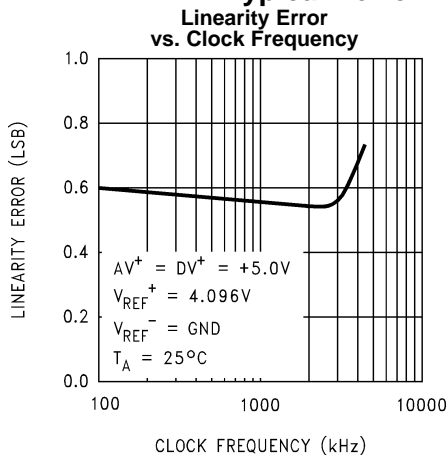

Figure 16.

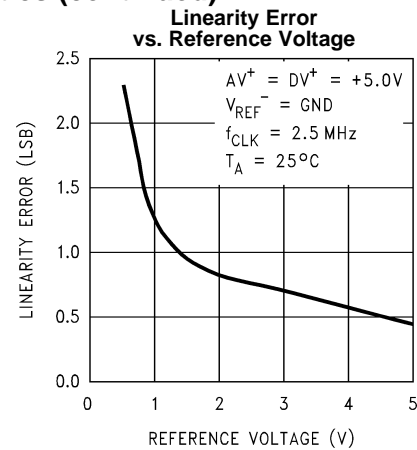

Figure 17.

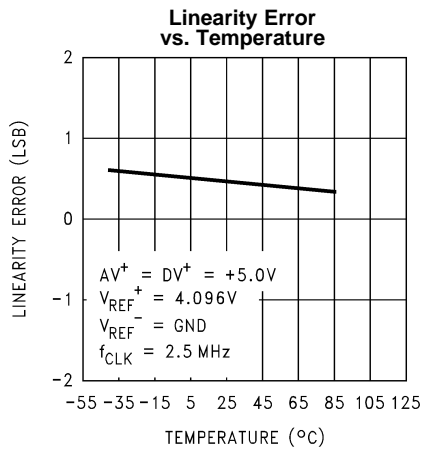

Figure 18.

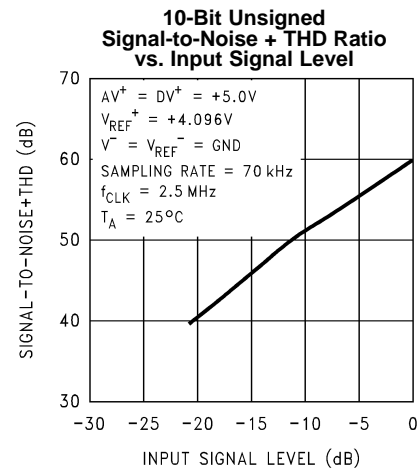

Figure 19.

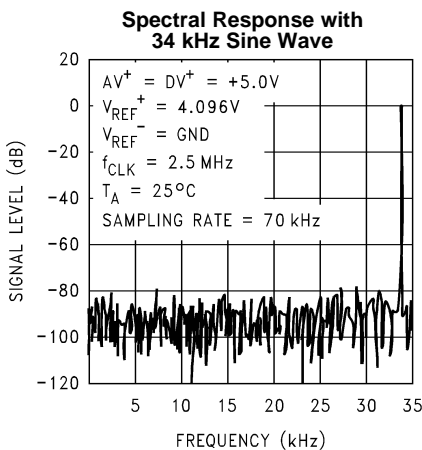

Figure 20.

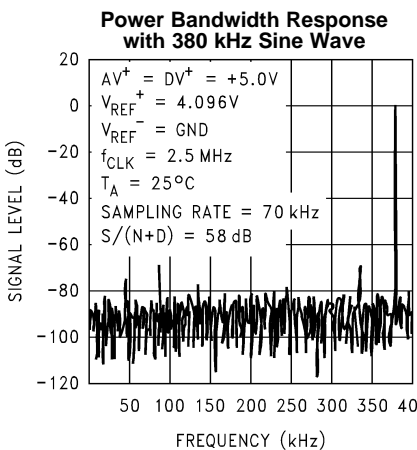

Figure 21.

Typical Reference Performance Characteristics

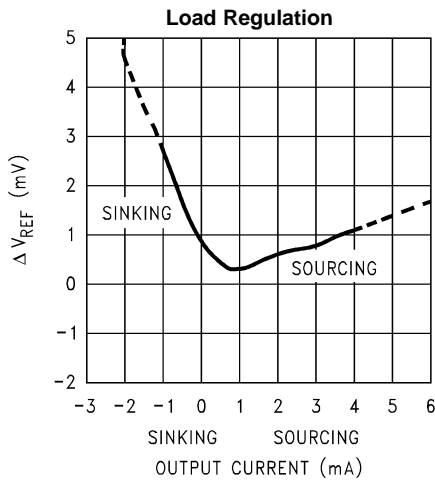

Figure 22.

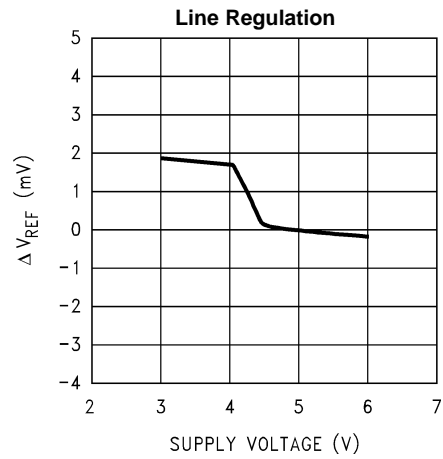

Figure 23.

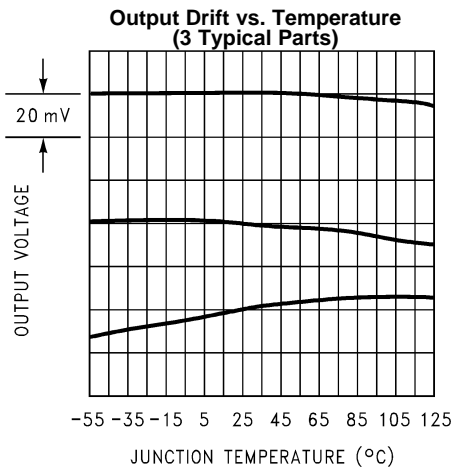

Figure 24.

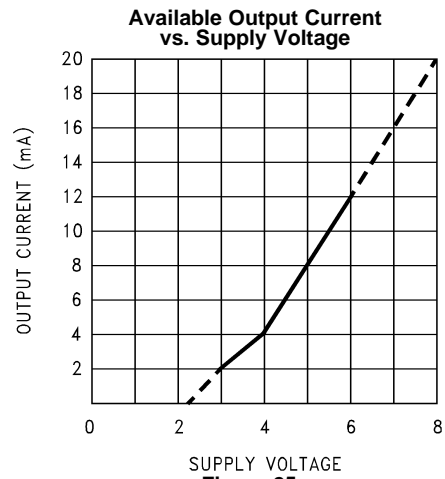

Figure 25.

TRI-STATE TEST CIRCUITS AND WAVEFORMS

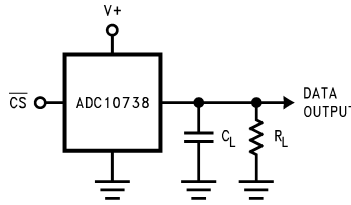

Figure 26.

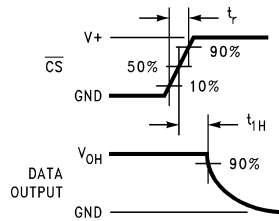

Figure 27.

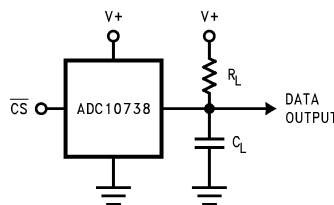

Figure 28.

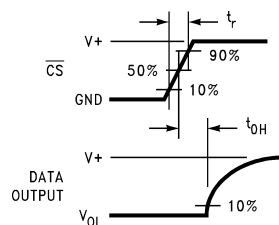

Figure 29.

Timing Diagrams

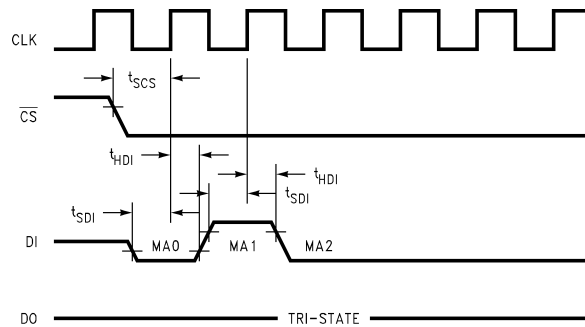

Figure 30. DI Timing

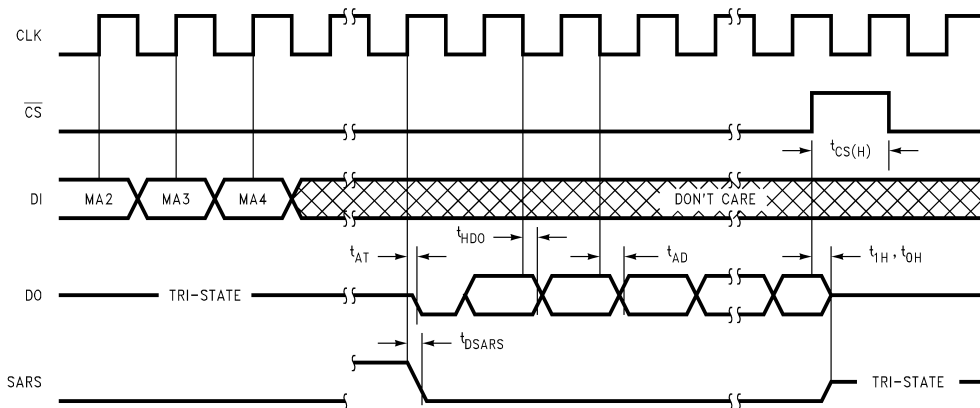

Figure 31. DO Timing

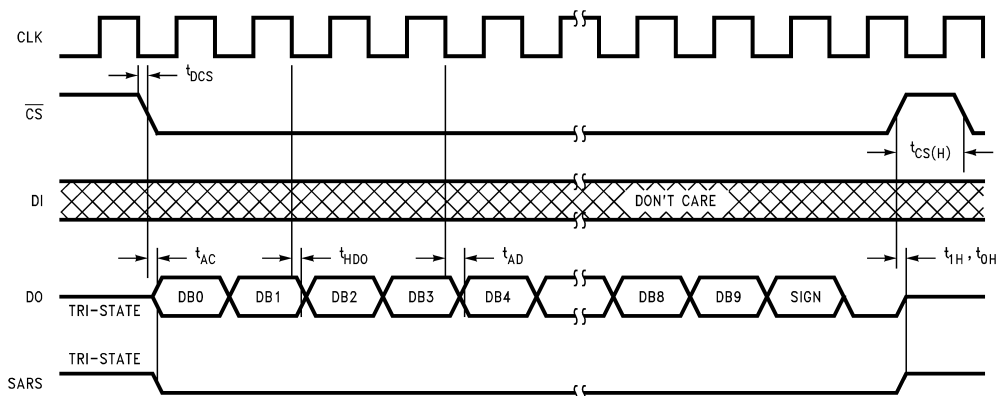

Figure 32. Delayed DO Timing

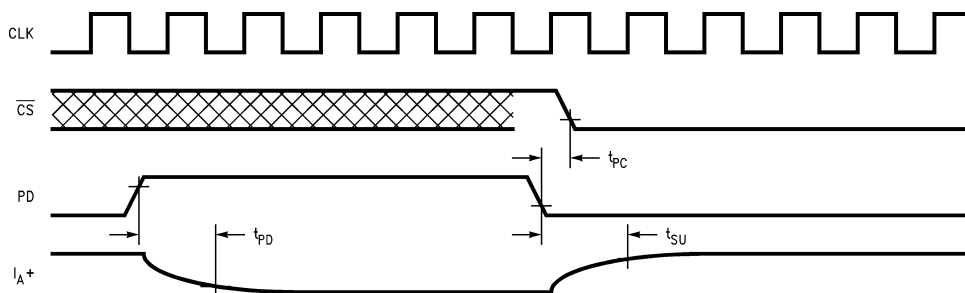

Figure 33. Hardware Power Up/Down Sequence

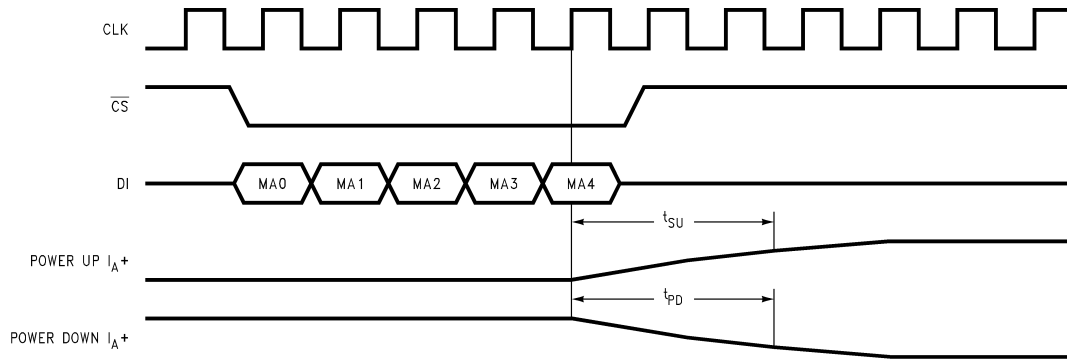
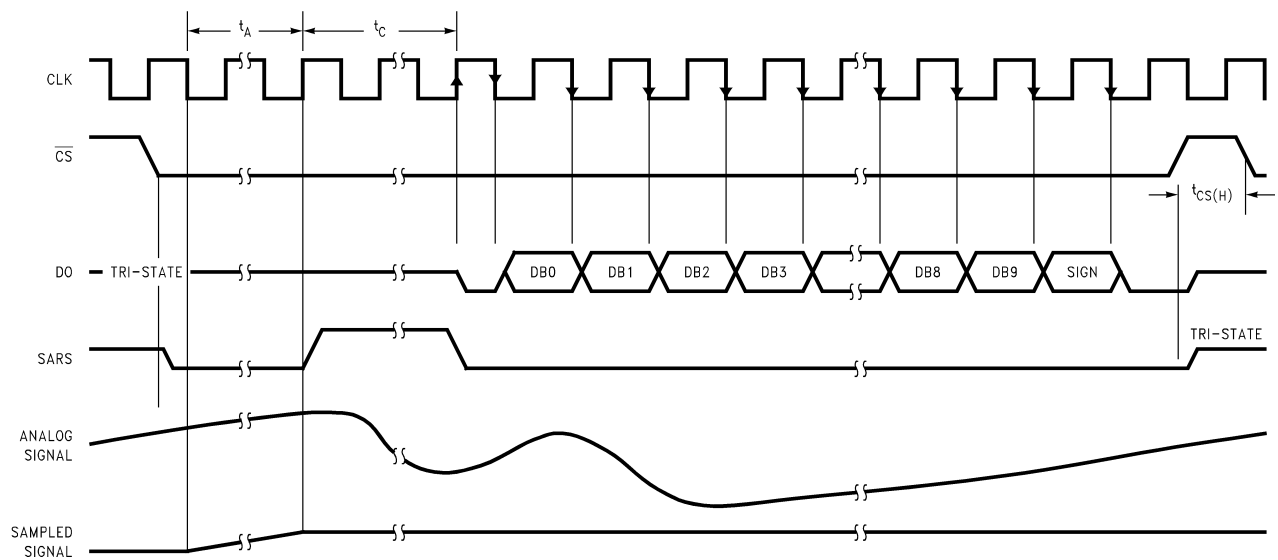

Figure 34. Software Power Up/Down Sequence



Note: If \overline{CS} is low during power up of the power supply voltages (AV^+ and DV^+) then \overline{CS} needs to go high for $t_{CS(H)}$. The data output after the first conversion is invalid.

The ADC10731 is obsolete. Information shown for reference only.

Figure 35. ADC10731 \overline{CS} Low during Conversion

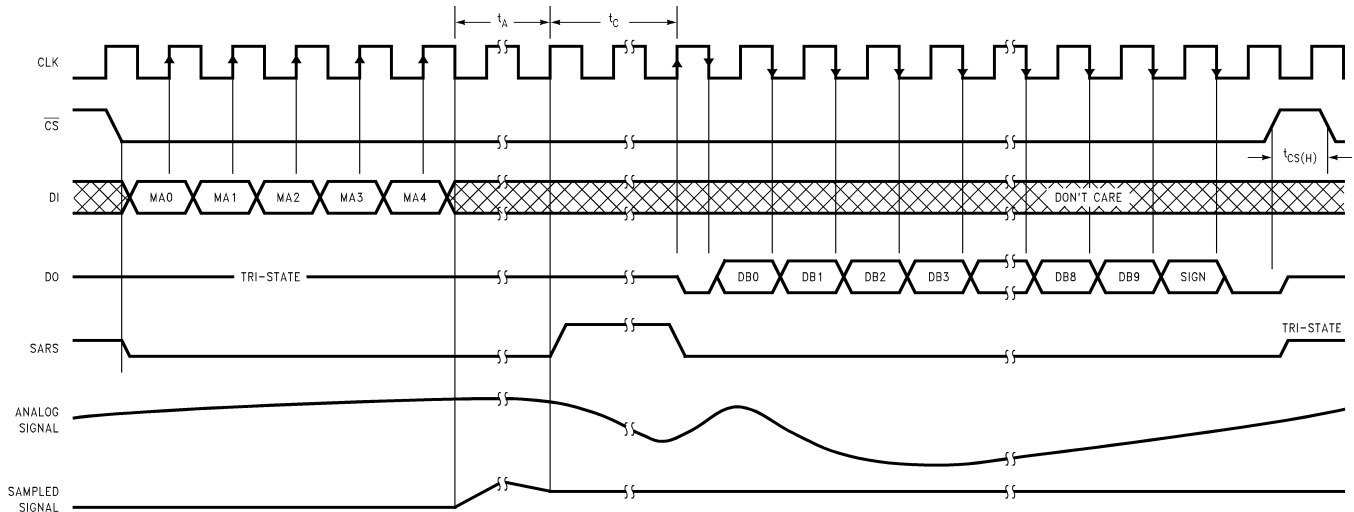

Note: If \overline{CS} is low during power up of the power supply voltages (AV^+ and DV^+) then \overline{CS} needs to go high for $t_{CS(H)}$. The data output after the first conversion is not valid.

The ADC10732 and the ADC10734 are obsolete. Information shown for reference only.

Figure 36. ADC10732, ADC10734 and ADC10738 \overline{CS} Low during Conversion

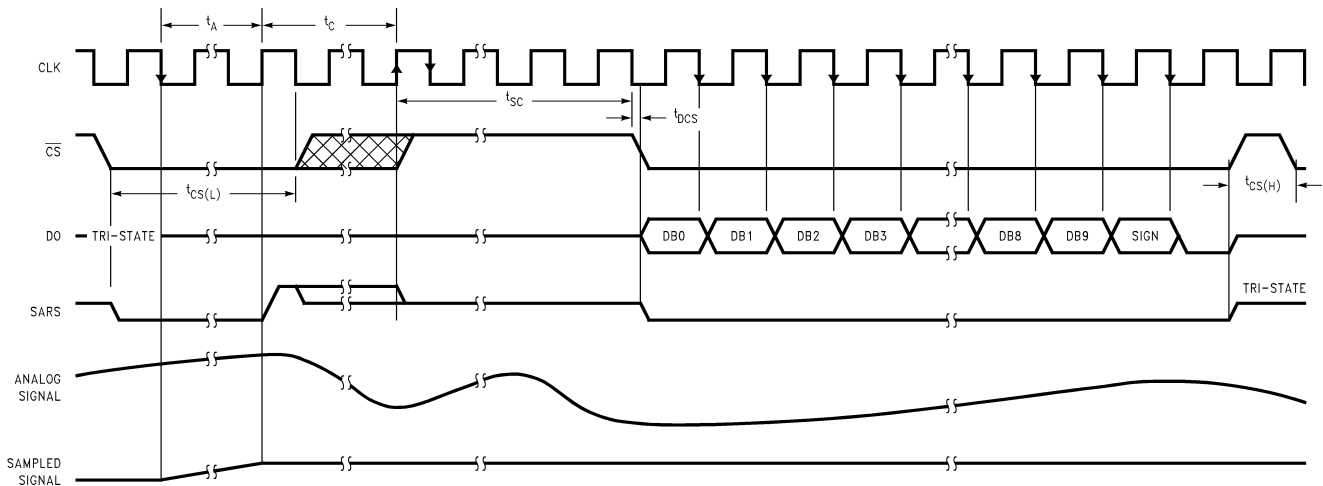

Note: If \overline{CS} is low during power up of the power supply voltages (AV^+ and DV^+) then \overline{CS} needs to go high for $t_{CS(H)}$. The data output after the first conversion is not valid.

The ADC10731 is obsolete. Information shown for reference only.

Figure 37. ADC10731 Using \overline{CS} to Delay Output of Data after a Conversion has Completed

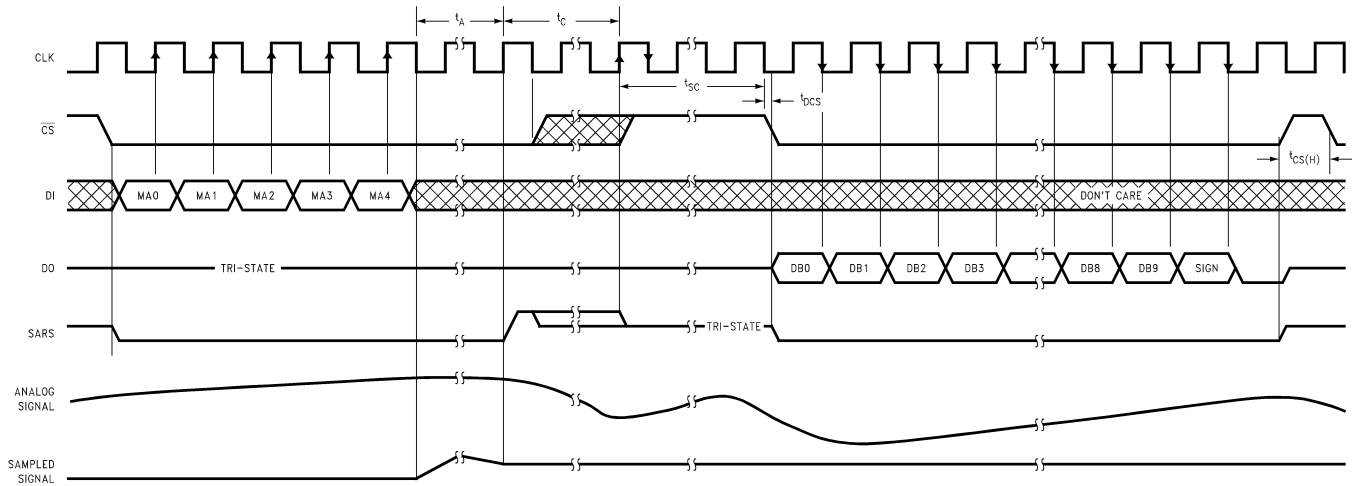

Note: If \overline{CS} is low during power up of the power supply voltages (AV^+ and DV^+) then \overline{CS} needs to go high for $t_{cs(H)}$. The data output after the first conversion is not valid.

The ADC10732 and the ADC10734 are obsolete. Information shown for reference only.

Figure 38. ADC10732, ADC10734 and ADC10738 Using \overline{CS} to Delay Output of Data After a Conversion has Completed

Table 2. ADC10738 Multiplexer Address Assignment

MUX Address					Channel Number									MUX MODE
MA0	MA1	MA2	MA3	MA4	CH0	CH1	CH2	CH3	CH4	CH5	CH6	CH7	COM	
PU	SING/ DIFF	ODD/ SIGN	SEL1	SEL0										
1	1	0	0	0	+								-	
1	1	0	0	1			+						-	
1	1	0	1	0					+				-	
1	1	0	1	1							+		-	Single-Ended
1	1	1	0	0		+							-	
1	1	1	0	1				+					-	
1	1	1	1	0						+			-	
1	1	1	1	1								+	-	
1	0	0	0	0	+	-								
1	0	0	0	1			+	-						
1	0	0	1	0					+	-				
1	0	0	1	1							+	-		Differential
1	0	1	0	0	-	+								
1	0	1	0	1			-	+						
1	0	1	1	0					-	+				
1	0	1	1	1							-	+		
0	X	X	X	X	Power Down (All Channels Disconnected)									

Table 3. ADC10734 (Obsolete) Multiplexer Address Assignment

MUX Address					Channel Number					MUX MODE
MA0	MA1	MA2	MA3	MA4	CH0	CH1	CH2	CH3	COM	
PU	SING/ DIFF	ODD/ SIGN	SEL1	SEL0						
1	1	0	0	0	+				-	
1	1	0	0	1			+		-	Single-Ended
1	1	1	0	0		+			-	
1	1	1	0	1				+	-	
1	0	0	0	0	+	-				
1	0	0	0	1			+	-		Differential
1	0	1	0	0	-	+				
1	0	1	0	1			-	+		
0	X	X	X	X	Power Down (All Channels Disconnected)					

Table 4. ADC10732 (Obsolete) Multiplexer Address Assignment

MUX Address					Channel Number			MUX MODE
MA0	MA1	MA2	MA3	MA4	CH0	CH1	COM	
PU	SING/DIFF	ODD/SIGN	SEL1	SEL0				
1	1	0	0	0	+		-	Single-Ended
1	1	1	0	0		+	-	
1	0	0	0	0	+	-		Differential
1	0	1	0	0	-	+		
0	X	X	X	X	Power Down (All Channels Disconnected)			

APPLICATIONS HINTS

The ADC10731, ADC10732 and ADC10734 are obsolete and discussed here for reference only.

The ADC10731/2/4/8 use successive approximation to digitize an analog input voltage. The DAC portion of the A/D converters uses a capacitive array and a resistive ladder structure. The structure of the DAC allows a very simple switching scheme to provide a versatile analog input multiplexer. This structure also provides a sample/hold. The ADC10731/2/4/8 have a 2.5V CMOS bandgap reference. The serial digital I/O interfaces to MICROWIRE and MICROWIRE+.

DIGITAL INTERFACE

There are two modes of operation. The fastest throughput rate is obtained when \overline{CS} is kept low during a conversion. The timing diagrams in [Figure 35](#) and [Figure 36](#) show the operation of the devices in this mode. \overline{CS} must be taken high for at least $t_{CS(H)}$ (1 CLK) between conversions. This is necessary to reset the internal logic. [Figure 37](#) and [Figure 38](#) show the operation of the devices when \overline{CS} is taken high while the ADC10731/2/4/8 is converting. \overline{CS} may be taken high during the conversion and kept high indefinitely to delay the output data. This mode simplifies the interface to other devices while the ADC10731/2/4/8 is busy converting.

Getting Started with a Conversion

The ADC10731/2/4/8 need to be initialized after the power supply voltage is applied. If \overline{CS} is low when the supply voltage is applied then \overline{CS} needs to be taken high for at least $t_{CS(H)}$ (1 clock period). The data output after the first conversion is not valid.

Software and Hardware Power Up/Down

These devices have the capability of software or hardware power down. [Figure 33](#) and [Figure 34](#) show the timing diagrams for hardware and software power up/down. In the case of hardware power down note that \overline{CS} needs to be high for t_{PC} after PD is taken low. When PD is high the device is powered down. The total quiescent current, when powered down, is typically 200 μ A with the clock at 2.5 MHz and 3 μ A with the clock off. The actual voltage level applied to a digital input will effect the power consumption of the device during power down. CMOS logic levels will give the least amount of current drain (3 μ A). TTL logic levels will increase the total current drain to 200 μ A.

These devices have resistive reference ladders which draw 600 μ A with a 2.5V reference voltage. The internal band gap reference voltage shuts down when power down is activated. If an external reference voltage is used, it will have to be shut down to minimize the total current drain of the device.

ARCHITECTURE

Before a conversion is started, during the analog input sampling period, (t_A), the sampled data comparator is zeroed. As the comparator is being zeroed the channel assigned to be the positive input is connected to the A/D's input capacitor. (The assignment procedure is explained in the [Table 1](#) section.) This charges the input 32C capacitor of the DAC to the positive analog input voltage. The switches shown in the DAC portion of [Figure 39](#) are set for this zeroing/acquisition period. The voltage at the input and output of the comparator are at equilibrium at this time. When the conversion is started, the comparator feedback switches are opened and the 32C input capacitor is then switched to the assigned negative input voltage. When the comparator feedback switch opens, a fixed amount of charge is trapped on the common plates of the capacitors. The voltage at the input of the comparator moves away from equilibrium when the 32C capacitor is switched to the assigned negative input voltage, causing the output of the comparator to go high ("1") or low ("0"). The SAR next goes through an algorithm, controlled by the output state of the comparator, that redistributes the charge on the capacitor array by switching the voltage on one side of the capacitors in the array. The objective of the SAR algorithm is to return the voltage at the input of the comparator as close as possible to equilibrium.

The switch position information at the completion of the successive approximation routine is a direct representation of the digital output. This data is then available to be shifted on the DO pin.

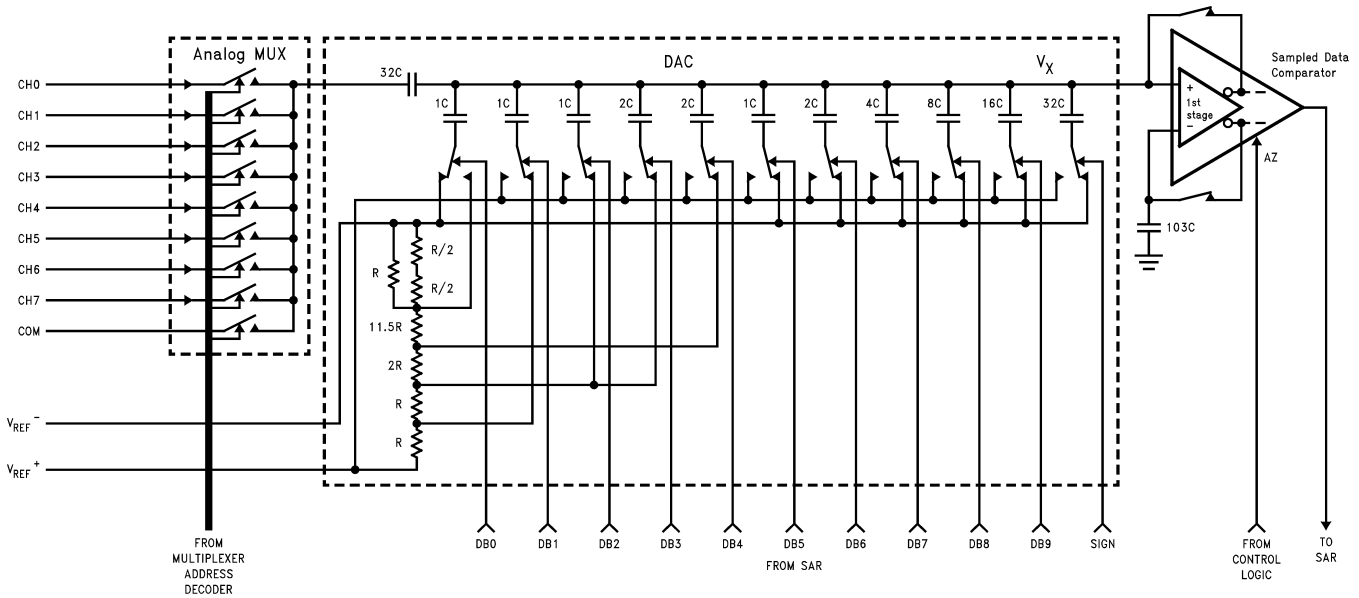

Figure 39. Detailed Diagram of the ADC10738 DAC and Analog Multiplexer Stages

APPLICATIONS INFORMATION

Multiplexer Configuration

The design of these converters utilizes a sampled-data comparator structure, which allows a differential analog input to be converted by the successive approximation routine.

The actual voltage converted is always the difference between an assigned “+” input terminal and a “-” input terminal. The polarity of each input terminal or pair of input terminals being converted indicates which line the converter expects to be the most positive.

A unique input multiplexing scheme has been utilized to provide multiple analog channels. The input channels can be software configured into three modes: differential, single-ended, or pseudo-differential. [Analog Input Multiplexer Options](#) illustrates the three modes using the 4-channel MUX of the ADC10734. The eight inputs of the ADC10738 can also be configured in any of the three modes. The single-ended mode has CH0–CH3 assigned as the positive input with COM serving as the negative input. In the differential mode, the ADC10734 channel inputs are grouped in pairs, CH0 with CH1 and CH2 with CH3. The polarity assignment of each channel in the pair is interchangeable. Finally, in the pseudo-differential mode CH0–CH3 are positive inputs referred to COM which is now a pseudo-ground. This pseudo-ground input can be set to any potential within the input common-mode range of the converter. The analog signal conditioning required in transducer-based data acquisition systems is significantly simplified with this type of input flexibility. One converter package can now handle ground-referred inputs and true differential inputs as well as signals referred to a specific voltage.

The analog input voltages for each channel can range from 50 mV below GND to 50 mV above $V^+ = DV^+ = AV^+$ without degrading conversion accuracy. If the voltage on an unselected channel exceeds these limits it may corrupt the reading of the selected channel.

Reference Considerations

The voltage difference between the V_{REF}^+ and V_{REF}^- inputs defines the analog input voltage span (the difference between $V_{IN}(\text{Max})$ and $V_{IN}(\text{Min})$) over which 1023 positive and 1024 negative possible output codes apply.

The value of the voltage on the V_{REF}^+ or V_{REF}^- inputs can be anywhere between $AV^+ + 50$ mV and -50 mV, so long as V_{REF}^+ is greater than V_{REF}^- . The ADC10731/2/4/8 can be used in either ratiometric applications or in systems requiring absolute accuracy. The reference pins must be connected to a voltage source capable of driving the minimum reference input resistance of 5 k Ω .

The internal 2.5V bandgap reference in the ADC10731/2/4/8 is available as an output on the VREFOut pin. To ensure optimum performance this output needs to be bypassed to ground with 100 μ F aluminum electrolytic or tantalum capacitor. The reference output can be unstable with capacitive loads greater than 100 pF and less than 100 μ F. Any capacitive loading less than 100 pF and greater than 100 μ F will not cause oscillation. Lower output noise can be obtained by increasing the output capacitance. A 100 μ F capacitor will yield a typical noise floor of

$$200 \text{ nV}/\sqrt{\text{Hz}} \quad (1)$$

The pseudo-differential and differential multiplexer modes allow for more flexibility in the analog input voltage range since the “zero” reference voltage is set by the actual voltage applied to the assigned negative input pin.

In a ratiometric system (Figure 40), the analog input voltage is proportional to the voltage used for the A/D reference. This voltage may also be the system power supply, so $V_{\text{REF}+}$ can also be tied to AV^+ . This technique relaxes the stability requirements of the system reference as the analog input and A/D reference move together maintaining the same output code for a given input condition.

For absolute accuracy (Figure 41), where the analog input varies between very specific voltage limits, the reference pin can be biased with a time- and temperature-stable voltage source that has excellent initial accuracy. The LM4040, LM4041 and LM185 references are suitable for use with the ADC10731/2/4/8.

The minimum value of V_{REF} ($V_{\text{REF}} = V_{\text{REF}+} - V_{\text{REF}-}$) can be quite small (see [Typical Performance Characteristics](#)) to allow direct conversion of transducer outputs providing less than a 5V output span. Particular care must be taken with regard to noise pickup, circuit layout and system error voltage sources when operating with a reduced span due to the increased sensitivity of the converter (1 LSB equals $V_{\text{REF}}/1024$).

The Analog Inputs

Due to the sampling nature of the analog inputs, at the clock edges short duration spikes of current will be seen on the selected assigned negative input. Input bypass capacitors should not be used if the source resistance is greater than 1 k Ω since they will average the AC current and cause an effective DC current to flow through the analog input source resistance. An op amp RC active lowpass filter can provide both impedance buffering and noise filtering should a high impedance signal source be required. Bypass capacitors may be used when the source impedance is very low without any degradation in performance.

In a true differential input stage, a signal that is common to both “+” and “-” inputs is canceled. For the ADC10731/2/4/8, the positive input of a selected channel pair is only sampled once before the start of a conversion during the acquisition time (t_A). The negative input needs to be stable during the complete conversion sequence because it is sampled before each decision in the SAR sequence. Therefore, any AC common-mode signal present on the analog inputs will not be completely canceled and will cause some conversion errors. For a sinusoid common-mode signal this error is:

$$V_{\text{ERROR(max)}} = V_{\text{PEAK}} (2 \pi f_{\text{CM}}) (t_C) \quad (2)$$

where f_{CM} is the frequency of the common-mode signal, V_{PEAK} is its peak voltage value, and t_C is the A/D's conversion time ($t_C = 12/f_{\text{CLK}}$). For example, for a 60 Hz common-mode signal to generate a $\frac{1}{4}$ LSB error (0.61 mV) with a 4.8 μ s conversion time, its peak value would have to be approximately 337 mV.

Analog Input Multiplexer Options

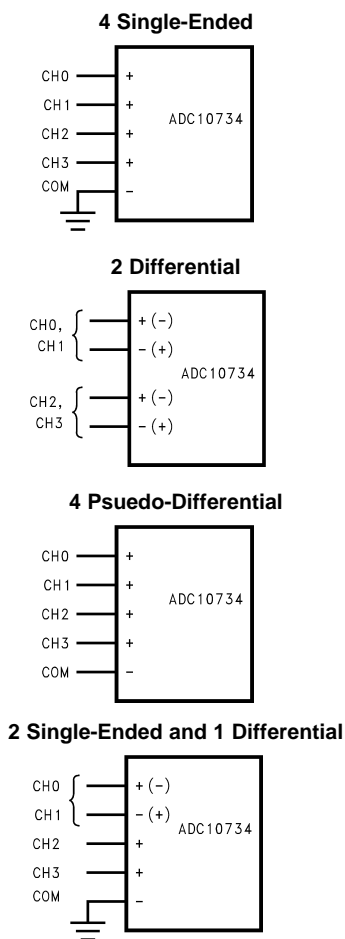

Different Reference Configurations

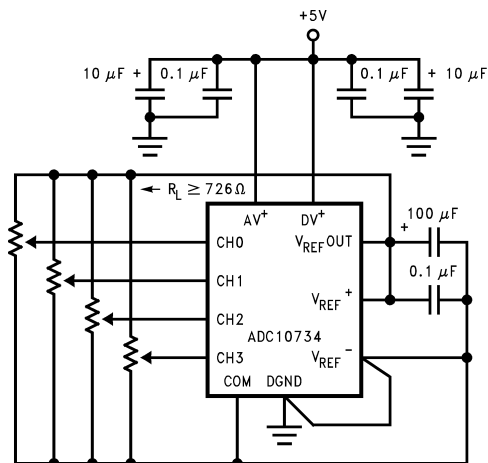

Figure 40. Ratiometric Using the Internal Reference

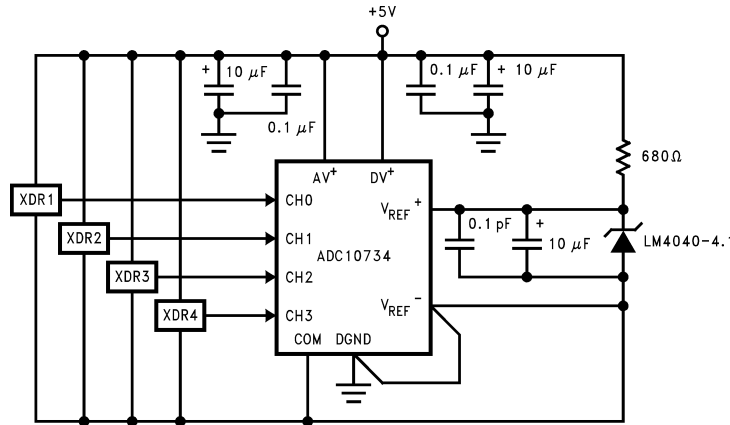

Figure 41. Absolute Using a 4.096V Span

Optional Adjustments

Zero Error

The zero error of the A/D converter relates to the location of the first riser of the transfer function (see Figure 7 Figure 8) and can be measured by grounding the minus input and applying a small magnitude voltage to the plus input. Zero error is the difference between actual DC input voltage which is necessary to just cause an output digital code transition from 000 0000 0000 to 000 0000 0001 and the ideal ½ LSB value (½ LSB = 1.22 mV for V_{REF} = + 2.500V).

The zero error of the A/D does not require adjustment. If the minimum analog input voltage value, V_{IN}(Min), is not ground, the effective “zero” voltage can be adjusted to a convenient value. The converter can be made to output an all zeros digital code for this minimum input voltage by biasing any minus input to V_{IN}(Min). This is useful for either the differential or pseudo-differential input channel configurations.

Full-Scale

The full-scale adjustment can be made by applying a differential input voltage which is 1½ LSB down from the desired analog full-scale voltage range and then adjusting the V_{REF} voltage (V_{REF} = V_{REF}⁺ – V_{REF}⁻) for a digital output code changing from 011 1111 1110 to 011 1111 1111. In bipolar signed operation this only adjusts the positive full scale error.

Adjusting for an Arbitrary Analog Input Voltage Range

If the analog zero voltage of the A/D is shifted away from ground (for example, to accommodate an analog input signal which does not go to ground), this new zero reference should be properly adjusted first. A plus input voltage which equals this desired zero reference plus ½ LSB is applied to selected plus input and the zero reference voltage at the corresponding minus input should then be adjusted to just obtain the 000 0000 0000 to 000 0000 0001 code transition.

The full-scale adjustment should be made [with the proper minus input voltage applied] by forcing a voltage to the plus input which is given by:

$$V_{IN(+)} f_s \text{ adj} = V_{MAX} - 1.5 \left[\frac{(V_{MAX} - V_{MIN})}{2^n} \right] \tag{3}$$

where V_{MAX} equals the high end of the analog input range, V_{MIN} equals the low end (the offset zero) of the analog range. Both V_{MAX} and V_{MIN} are ground referred. The V_{REF} (V_{REF} = V_{REF}⁺ – V_{REF}⁻) voltage is then adjusted to provide a code change from 011 1111 1110 to 011 1111 1111. Note, when using a pseudo-differential or differential multiplexer mode where V_{REF}⁺ and V_{REF}⁻ are placed within the V⁺ and GND range, the individual values of V_{REF} and V_{REF}⁻ do not matter, only the difference sets the analog input voltage span. This completes the adjustment procedure.

The Input Sample and Hold

The ADC10731/2/4/8's sample/hold capacitor is implemented in the capacitor array. After the channel address is loaded, the array is switched to sample the selected positive analog input. The sampling period for the assigned positive input is maintained for the duration of the acquisition time (t_A) 4.5 clock cycles.

This acquisition window of 4.5 clock cycles is available to allow the voltage on the capacitor array to settle to the positive analog input voltage. Any change in the analog voltage on a selected positive input before or after the acquisition window will not effect the A/D conversion result.

In the simplest case, the array's acquisition time is determined by the R_{ON} (3 k Ω) of the multiplexer switches, the stray input capacitance C_{S1} (3.5 pF) and the total array (C_L) and stray (C_{S2}) capacitance (48 pF). For a large source resistance the analog input can be modeled as an RC network as shown in Figure 42. The values shown yield an acquisition time of about 1.1 μ s for 10-bit unipolar or 10-bit plus sign accuracy with a zero-to-full-scale change in the input voltage. External source resistance and capacitance will lengthen the acquisition time and should be accounted for. Slowing the clock will lengthen the acquisition time, thereby allowing a larger external source resistance.

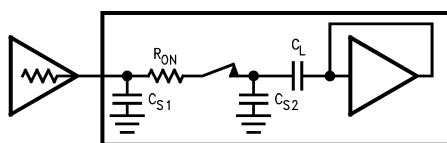
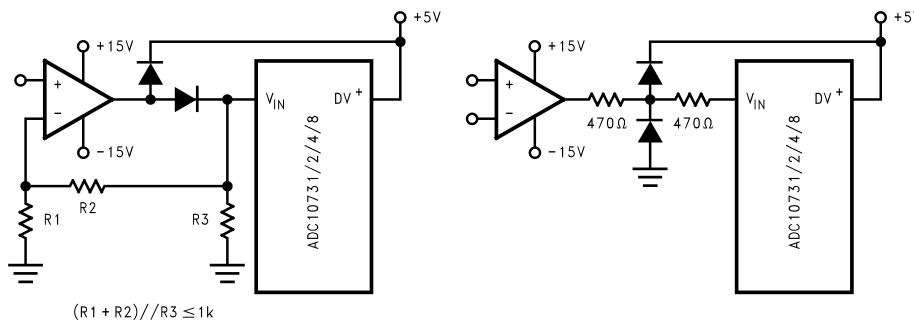

Figure 42. Analog Input Model

The signal-to-noise ratio of an ideal A/D is the ratio of the RMS value of the full scale input signal amplitude to the value of the total error amplitude (including noise) caused by the transfer function of the ideal A/D. An ideal 10-bit plus sign A/D converter with a total unadjusted error of 0 LSB would have a signal-to-(noise + distortion) ratio of about 68 dB, which can be derived from the equation:

$$S/(N + D) = 6.02(n) + 1.76 \tag{4}$$

where $S/(N + D)$ is in dB and n is the number of bits.



$$(R1 + R2) / R3 \leq 1k$$

Note: Diodes are 1N914.

Note: The protection diodes should be able to withstand the output current of the op amp under current limit.

Figure 43. Protecting the Analog Inputs

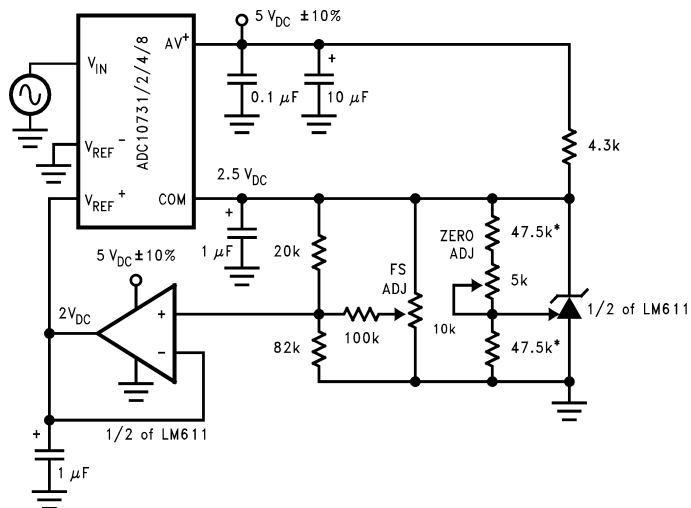

*1% resistors

Figure 44. Zero-Shift and Span-Adjust for Signed or Unsigned, Single-Ended Multiplexer Assignment, Signed Analog Input Range of $0.5V \leq V_{IN} \leq 4.5V$

REVISION HISTORY

Changes from Revision C (March 2013) to Revision D	Page
<hr/> <ul style="list-style-type: none">• Changed layout of National Data Sheet to TI format	<hr/> 26

PACKAGING INFORMATION

Orderable part number	Status (1)	Material type (2)	Package Pins	Package qty Carrier	RoHS (3)	Lead finish/ Ball material (4)	MSL rating/ Peak reflow (5)	Op temp (°C)	Part marking (6)
ADC10738CIWM/NOPB	Active	Production	SOIC (DW) 24	30 TUBE	Yes	SN	Level-3-260C-168 HR	-40 to 85	ADC10738 CIWM
ADC10738CIWM/NOPB.B	Active	Production	SOIC (DW) 24	30 TUBE	Yes	SN	Level-3-260C-168 HR	-40 to 85	ADC10738 CIWM
ADC10738CIWMX/NOPB	Active	Production	SOIC (DW) 24	1000 LARGE T&R	Yes	SN	Level-3-260C-168 HR	-40 to 85	ADC10738 CIWM
ADC10738CIWMX/NOPB.B	Active	Production	SOIC (DW) 24	1000 LARGE T&R	Yes	SN	Level-3-260C-168 HR	-40 to 85	ADC10738 CIWM

(1) **Status:** For more details on status, see our [product life cycle](#).

(2) **Material type:** When designated, preproduction parts are prototypes/experimental devices, and are not yet approved or released for full production. Testing and final process, including without limitation quality assurance, reliability performance testing, and/or process qualification, may not yet be complete, and this item is subject to further changes or possible discontinuation. If available for ordering, purchases will be subject to an additional waiver at checkout, and are intended for early internal evaluation purposes only. These items are sold without warranties of any kind.

(3) **RoHS values:** Yes, No, RoHS Exempt. See the [TI RoHS Statement](#) for additional information and value definition.

(4) **Lead finish/Ball material:** Parts may have multiple material finish options. Finish options are separated by a vertical ruled line. Lead finish/Ball material values may wrap to two lines if the finish value exceeds the maximum column width.

(5) **MSL rating/Peak reflow:** The moisture sensitivity level ratings and peak solder (reflow) temperatures. In the event that a part has multiple moisture sensitivity ratings, only the lowest level per JEDEC standards is shown. Refer to the shipping label for the actual reflow temperature that will be used to mount the part to the printed circuit board.

(6) **Part marking:** There may be an additional marking, which relates to the logo, the lot trace code information, or the environmental category of the part.

Multiple part markings will be inside parentheses. Only one part marking contained in parentheses and separated by a "-" will appear on a part. If a line is indented then it is a continuation of the previous line and the two combined represent the entire part marking for that device.

Important Information and Disclaimer: The information provided on this page represents TI's knowledge and belief as of the date that it is provided. TI bases its knowledge and belief on information provided by third parties, and makes no representation or warranty as to the accuracy of such information. Efforts are underway to better integrate information from third parties. TI has taken and continues to take reasonable steps to provide representative and accurate information but may not have conducted destructive testing or chemical analysis on incoming materials and chemicals. TI and TI suppliers consider certain information to be proprietary, and thus CAS numbers and other limited information may not be available for release.

In no event shall TI's liability arising out of such information exceed the total purchase price of the TI part(s) at issue in this document sold by TI to Customer on an annual basis.

TAPE AND REEL INFORMATION

QUADRANT ASSIGNMENTS FOR PIN 1 ORIENTATION IN TAPE

*All dimensions are nominal

Device	Package Type	Package Drawing	Pins	SPQ	Reel Diameter (mm)	Reel Width W1 (mm)	A0 (mm)	B0 (mm)	K0 (mm)	P1 (mm)	W (mm)	Pin1 Quadrant
ADC10738CIWMX/NOPB	SOIC	DW	24	1000	330.0	24.4	10.8	15.9	3.2	12.0	24.0	Q1

TAPE AND REEL BOX DIMENSIONS

*All dimensions are nominal

Device	Package Type	Package Drawing	Pins	SPQ	Length (mm)	Width (mm)	Height (mm)
ADC10738CIWMX/NOPB	SOIC	DW	24	1000	356.0	356.0	45.0

TUBE

*All dimensions are nominal

Device	Package Name	Package Type	Pins	SPQ	L (mm)	W (mm)	T (μm)	B (mm)
ADC10738CIWM/NOPB	DW	SOIC	24	30	495	15	5842	7.87
ADC10738CIWM/NOPB.B	DW	SOIC	24	30	495	15	5842	7.87

DW (R-PDSO-G24)

PLASTIC SMALL OUTLINE

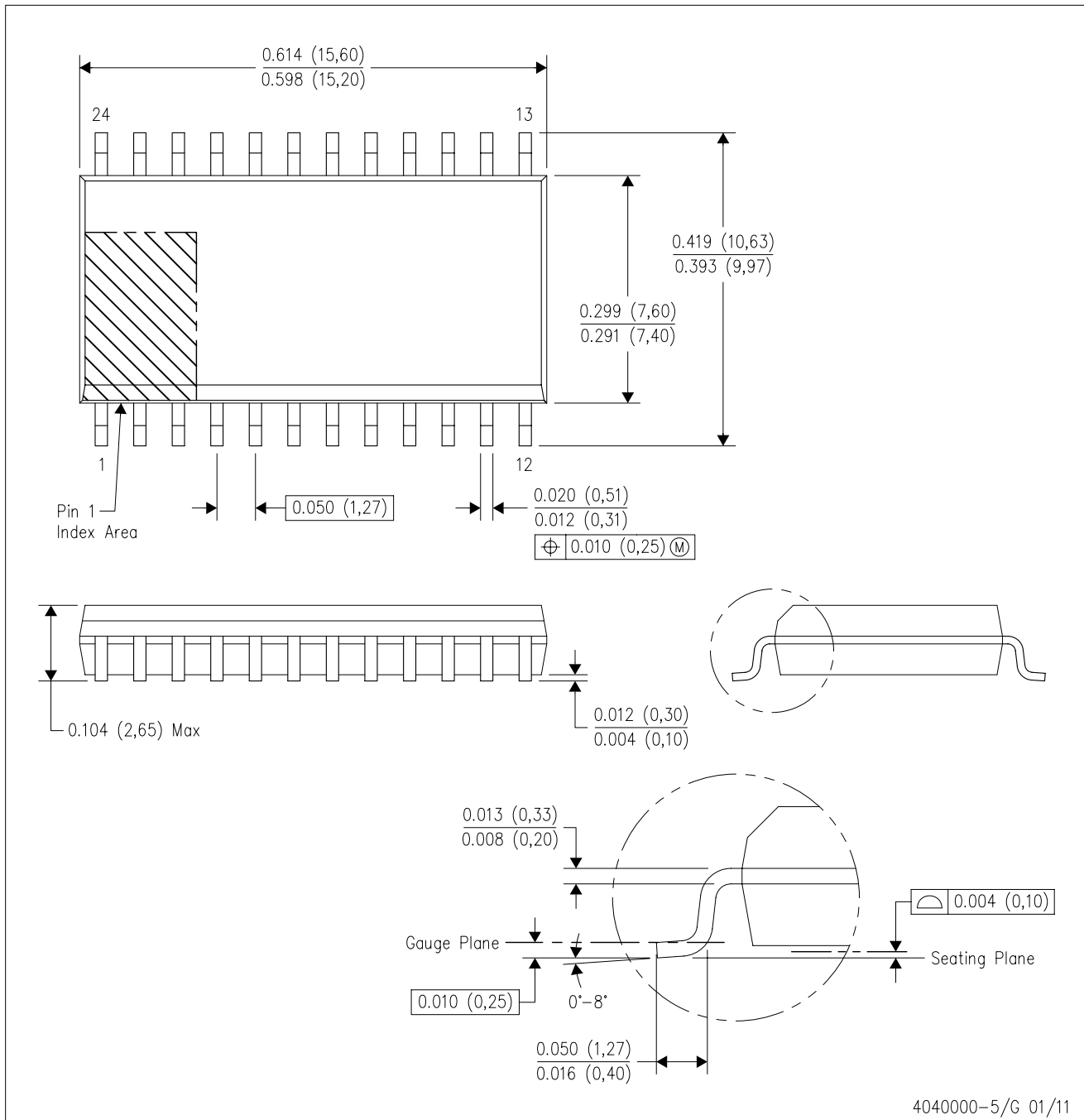

- NOTES:
- A. All linear dimensions are in inches (millimeters). Dimensioning and tolerancing per ASME Y14.5M-1994.
 - B. This drawing is subject to change without notice.
 - C. Body dimensions do not include mold flash or protrusion not to exceed 0.006 (0,15).
 - D. Falls within JEDEC MS-013 variation AD.

IMPORTANT NOTICE AND DISCLAIMER

TI PROVIDES TECHNICAL AND RELIABILITY DATA (INCLUDING DATASHEETS), DESIGN RESOURCES (INCLUDING REFERENCE DESIGNS), APPLICATION OR OTHER DESIGN ADVICE, WEB TOOLS, SAFETY INFORMATION, AND OTHER RESOURCES "AS IS" AND WITH ALL FAULTS, AND DISCLAIMS ALL WARRANTIES, EXPRESS AND IMPLIED, INCLUDING WITHOUT LIMITATION ANY IMPLIED WARRANTIES OF MERCHANTABILITY, FITNESS FOR A PARTICULAR PURPOSE OR NON-INFRINGEMENT OF THIRD PARTY INTELLECTUAL PROPERTY RIGHTS.

These resources are intended for skilled developers designing with TI products. You are solely responsible for (1) selecting the appropriate TI products for your application, (2) designing, validating and testing your application, and (3) ensuring your application meets applicable standards, and any other safety, security, regulatory or other requirements.

These resources are subject to change without notice. TI grants you permission to use these resources only for development of an application that uses the TI products described in the resource. Other reproduction and display of these resources is prohibited. No license is granted to any other TI intellectual property right or to any third party intellectual property right. TI disclaims responsibility for, and you fully indemnify TI and its representatives against any claims, damages, costs, losses, and liabilities arising out of your use of these resources.

TI's products are provided subject to [TI's Terms of Sale](#), [TI's General Quality Guidelines](#), or other applicable terms available either on ti.com or provided in conjunction with such TI products. TI's provision of these resources does not expand or otherwise alter TI's applicable warranties or warranty disclaimers for TI products. Unless TI explicitly designates a product as custom or customer-specified, TI products are standard, catalog, general purpose devices.

TI objects to and rejects any additional or different terms you may propose.

Copyright © 2026, Texas Instruments Incorporated

Last updated 10/2025