



Two 1-Bit, 10MHz, 2nd-Order Delta-Sigma Modulators

FEATURES

- 16-Bit Resolution
- 14-Bit Linearity
- $\pm 2.5V$ Input Range at 2.5V
- Internal Reference Voltage: 2%
- Gain Error: 0.5%
- Two Independent Delta-Sigma Modulators
- Two Input Reference Buffers
- On-Chip 20MHz Oscillator
- Selectable Internal or External Clock
- Operating Temperature Range:
-40°C to +85°C
- QFN-24 (4x4) Package

APPLICATIONS

- Motor Control
- Current Measurement
- Industrial Process Control
- Instrumentation
- Resolver

DESCRIPTION

The ADS1205 is a two-channel, high-performance, delta-sigma ($\Delta\Sigma$) modulator with more than 98dB dynamic range, operating from a single +5V supply. The differential inputs are ideal for direct connection to transducers in an industrial environment. With the appropriate digital filter and modulator rate, the device can be used to achieve 16-bit analog-to-digital (A/D) conversion with no missing codes. Effective resolution of 14 bits can be obtained with a digital filter bandwidth of 40kHz at a modulator rate of 10MHz. The ADS1205 is designed for use in high-resolution measurement applications including current measurements, smart transmitters, industrial process control, and resolvers. It is available in a QFN-24 (4x4) package.

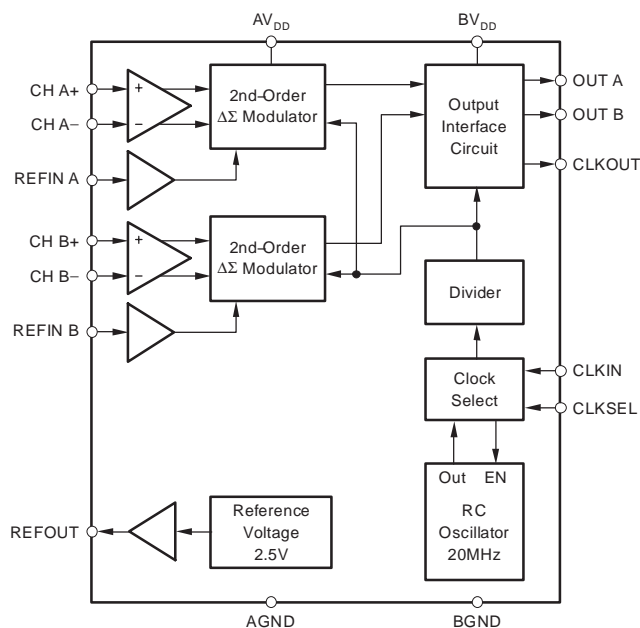

Please be aware that an important notice concerning availability, standard warranty, and use in critical applications of Texas Instruments semiconductor products and disclaimers thereto appears at the end of this data sheet.

All trademarks are the property of their respective owners.



This integrated circuit can be damaged by ESD. Texas Instruments recommends that all integrated circuits be handled with appropriate precautions. Failure to observe proper handling and installation procedures can cause damage.

ESD damage can range from subtle performance degradation to complete device failure. Precision integrated circuits may be more susceptible to damage because very small parametric changes could cause the device not to meet its published specifications.

Package/Ordering Information

For the most current package and ordering information, see the Package Option Addendum at the end of this document, or see the TI web site at www.ti.com.

ABSOLUTE MAXIMUM RATINGS

over operating free-air temperature range unless otherwise noted⁽¹⁾

	ADS1205	UNIT
Supply voltage, AGND to AV _{DD}	-0.3 to 6	V
Supply voltage, BGND to BV _{DD}	-0.3 to 6	V
Analog input voltage with respect to AGND	AGND - 0.3 to AV _{DD} + 0.3	V
Reference input voltage with respect to AGND	AGND - 0.3 to AV _{DD} + 0.3	V
Digital input voltage with respect to BGND	BGND - 0.3 to BV _{DD} + 0.3	V
Ground voltage difference, AGND to BGND	±0.3	V
Voltage differences, BV _{DD} to AGND	-0.3 to 6	V
Input current to any pin except supply	±10	mA
Power dissipation	See Dissipation Rating table	
Operating virtual junction temperature range, T _J	-40 to +150	°C
Operating free-air temperature range, T _A	-40 to +85	°C
Storage temperature range, T _{STG}	-65 to +150	°C

⁽¹⁾ Stresses beyond those listed under *Absolute Maximum Ratings* may cause permanent damage to the device. These are stress ratings only, and functional operation of the device at these or any other conditions beyond those indicated under *Recommended Operating Conditions* is not implied. Exposure to absolute-maximum-rated conditions for extended periods may affect device reliability.

DISSIPATION RATINGS

PACKAGE	T _A ≤ 25°C POWER RATING	DERATING FACTOR ABOVE T _A = 25°C ⁽¹⁾	T _A = 70°C POWER RATING	T _A = 85°C POWER RATING
QFN-24 (4x4)	2193mW	21.929mW/°C	1206mW	877.2mW

⁽¹⁾ This is the inverse of the traditional junction-to-ambient thermal resistance (R_{θJA}). Thermal resistances are not production tested and are for informational purposes only.

RECOMMENDED OPERATING CONDITIONS

PARAMETER	MIN	NOM	MAX	UNIT
Supply voltage, AGND to AV _{DD}	4.5	5	5.5	V
Supply voltage, BGND to BV _{DD}	Low-Voltage Levels		3.6	V
	5V Logic Levels		5.5	V
Reference input voltage	0.5	2.5	2.6	V
Operating common-mode signal	-IN	2.5		V
Analog inputs	+IN - (-IN)		±0.8 × REFIN	V
External clock ⁽¹⁾	16	20	24	MHz
Operating junction temperature range, T _J	-40		105	°C

⁽¹⁾ With reduced accuracy, clock can go from 1MHz up to 33MHz; see Typical Characteristics.

ELECTRICAL CHARACTERISTICS

Over recommended operating free-air temperature range at -40°C to $+85^{\circ}\text{C}$, $\text{AV}_{\text{DD}} = 5\text{V}$, $\text{BV}_{\text{DD}} = 3\text{V}$, $\text{CH x+} = 0.5\text{V}$ to 4.5V , $\text{CH x-} = 2.5\text{V}$, $\text{REFIN} = \text{REFOUT} = \text{internal } +2.5\text{V}$, $\text{CLKIN} = 20\text{MHz}$, and 16-bit Sinc³ filter with decimation by 256, unless otherwise noted.

PARAMETER	TEST CONDITIONS	ADS1205I			UNITS	
		MIN	TYP(1)	MAX		
Resolution		16			Bits	
DC Accuracy						
INL	Integral linearity error(2)		-1.4	± 3	LSB	
			-0.002	± 0.005	% FSR	
	Integral linearity match			6	LSB	
				0.009	% FSR	
DNL	Differential nonlinearity(3)			± 1	LSB	
V _{OS}	Input offset error(4)		-1.2	± 3	mV	
			0.1	2	mV	
TCV _{OS}	Input offset error drift		1.1	8	$\mu\text{V}/^{\circ}\text{C}$	
G _{ERR}	Gain error(4)	Referenced to V _{REF}		-0.01	± 0.5	% FSR
				0.09	0.5	% FSR
TCG _{ERR}	Gain error drift		1.3		ppm/ $^{\circ}\text{C}$	
PSRR	Power-supply rejection ratio	$4.75\text{V} < \text{AV}_{\text{DD}} < 5.25\text{V}$	78		dB	
Analog Input						
FSR	Full-scale differential range	(CH x+) – (CH x-); CH x- = 2.5V		± 2.5	V	
				± 2	V	
	Specified differential range	(CH x+) – (CH x-); CH x- = 2.5V		± 2	V	
	Maximum operating input range(3)		0	AV _{DD}	V	
	Input capacitance	Common-mode	3		pF	
	Input leakage current	CLK turned off	± 1		nA	
	Differential input resistance		100		k Ω	
	Differential input capacitance		2.5		pF	
CMRR	Common-mode rejection ratio	At DC	108		dB	
		V _{IN} = $\pm 1.25\text{V}_{\text{pp}}$ at 40kHz	117		dB	
BW	Bandwidth	FS sine wave, -3dB	50		MHz	
Sampling Dynamics						
	Internal clock frequency	CLKSEL = 1	8	9.8	12	MHz
CLKIN	External clock frequency(5)	CLKSEL = 0	1	20	24	MHz
AC Accuracy						
THD	Total harmonic distortion	V _{IN} = $\pm 2\text{V}_{\text{pp}}$ at 5kHz	-96.6	-88	dB	
SFDR	Spurious-free dynamic range	V _{IN} = $\pm 2\text{V}_{\text{pp}}$ at 5kHz	92	98	dB	
SNR	Signal-to-noise ratio	V _{IN} = $\pm 2\text{V}_{\text{pp}}$ at 5kHz	86	88.9	dB	
SINAD	Signal-to-noise + distortion	V _{IN} = $\pm 2\text{V}_{\text{pp}}$ at 5kHz	85	88.2	dB	
	Channel-to-channel isolation(3)	V _{IN} = $\pm 2\text{V}_{\text{pp}}$ at 50kHz	100		dB	
ENOB	Effective number of bits		14	14.5	Bits	

(1) All typical values are at T_A = $+25^{\circ}\text{C}$.

(2) Integral nonlinearity is defined as the maximum deviation of the line through the end points of the specified input range of the transfer curve for CH x+ = -2V to $+2\text{V}$ at 2.5V, expressed either as the number of LSBs or as a percent of measured input range (4V).

(3) Ensured by design.

(4) Maximum values, including temperature drift, are ensured over the full specified temperature range.

(5) With reduced accuracy, the clock frequency can go from 1MHz to 33MHz.

(6) Applicable for 5.0V nominal supply: BV_{DD} (min) = 4.5V and BV_{DD} (max) = 5.5V.

(7) Applicable for 3.0V nominal supply: BV_{DD} (min) = 2.7V and BV_{DD} (max) = 3.6V.

ELECTRICAL CHARACTERISTICS (continued)

Over recommended operating free-air temperature range at -40°C to $+85^{\circ}\text{C}$, $\text{AV}_{\text{DD}} = 5\text{V}$, $\text{BV}_{\text{DD}} = 3\text{V}$, $\text{CH}_{\text{x}+} = 0.5\text{V}$ to 4.5V , $\text{CH}_{\text{x}-} = 2.5\text{V}$, $\text{REFIN} = \text{REFOUT} = \text{internal } +2.5\text{V}$, $\text{CLKIN} = 20\text{MHz}$, and 16-bit Sinc³ filter with decimation by 256, unless otherwise noted.

PARAMETER	TEST CONDITIONS	ADS1205I			UNITS		
		MIN	TYP(1)	MAX			
Voltage Reference Output							
V _{REFOUT}	Reference voltage output	-40°C to $+85^{\circ}\text{C}$		2.450	2.5	2.550	V
dV _{REFOUT} /dT	Output voltage temperature drift			±20			ppm/°C
	Output voltage noise	f = 0.1Hz to 10Hz, C _L = 10μF		10			μVrms
		f = 10Hz to 10kHz, C _L = 10μF		12			μVrms
PSRR	Power-supply rejection ratio			60			dB
I _{OUT}	Output current			10			μA
I _{SC}	Short-circuit current			0.5			mA
	Turn-on settling time	to 0.1% at C _L = 0		100			μs
Voltage Reference Input							
V _{IN}	Reference voltage input			0.5	2.5	2.6	V
	Reference input resistance			100			MΩ
	Reference input capacitance			5			pF
	Reference input current					1	μA
Digital Inputs(6)							
	Logic family			CMOS with Schmitt Trigger			
V _{IH}	High-level input voltage			0.7×BV _{DD}	BV _{DD} +0.3		V
V _{IL}	Low-level input voltage			-0.3	0.3×BV _{DD}		V
I _{IN}	Input current	V _I = BV _{DD} or GND				±50	nA
C _I	Input capacitance			5			pF
Digital Outputs(6)							
	Logic family			CMOS			
V _{OH}	High-level output voltage	BV _{DD} = 4.5V, I _{OH} = -100μA		4.44			V
V _{OL}	Low-level output voltage	BV _{DD} = 4.5V, I _{OL} = +100μA				0.5	V
C _O	Output capacitance			5			pF
C _L	Load capacitance					30	pF
	Data format			Bit Stream			

(1) All typical values are at T_A = +25°C.

(2) Integral nonlinearity is defined as the maximum deviation of the line through the end points of the specified input range of the transfer curve for CH_{x+} = -2V to +2V at 2.5V, expressed either as the number of LSBs or as a percent of measured input range (4V).

(3) Ensured by design.

(4) Maximum values, including temperature drift, are ensured over the full specified temperature range.

(5) With reduced accuracy, the clock frequency can go from 1MHz to 33MHz.

(6) Applicable for 5.0V nominal supply: BV_{DD} (min) = 4.5V and BV_{DD} (max) = 5.5V.

(7) Applicable for 3.0V nominal supply: BV_{DD} (min) = 2.7V and BV_{DD} (max) = 3.6V.

ELECTRICAL CHARACTERISTICS (continued)

Over recommended operating free-air temperature range at -40°C to $+85^{\circ}\text{C}$, $\text{AV}_{\text{DD}} = 5\text{V}$, $\text{BV}_{\text{DD}} = 3\text{V}$, $\text{CH x+} = 0.5\text{V}$ to 4.5V , $\text{CH x-} = 2.5\text{V}$, $\text{REFIN} = \text{REFOUT} = \text{internal } +2.5\text{V}$, $\text{CLKIN} = 20\text{MHz}$, and 16-bit Sinc³ filter with decimation by 256, unless otherwise noted.

PARAMETER	TEST CONDITIONS	ADS1205I			UNITS	
		MIN	TYP(1)	MAX		
Digital Inputs(7)						
	Logic family	LVCMOS				
V_{IH}	High-level input voltage	$\text{BV}_{\text{DD}} = 3.6\text{V}$	2	$\text{BV}_{\text{DD}}+0.3$	V	
V_{IL}	Low-level input voltage	$\text{BV}_{\text{DD}} = 2.7\text{V}$	-0.3	0.8	V	
I_{IN}	Input current	$V_{\text{I}} = \text{BV}_{\text{DD}}$ or GND		± 50	nA	
C_{I}	Input capacitance		5		pF	
Digital Outputs(7)						
	Logic family	LVCMOS				
V_{OH}	High-level output voltage	$\text{BV}_{\text{DD}} = 2.7\text{V}$, $I_{\text{OH}} = -100\mu\text{A}$	$\text{BV}_{\text{DD}}-0.2$		V	
V_{OL}	Low-level output voltage	$\text{BV}_{\text{DD}} = 2.7\text{V}$, $I_{\text{OL}} = +100\mu\text{A}$		0.2	V	
C_{O}	Output capacitance		5		pF	
C_{L}	Load capacitance			30	pF	
	Data format	Bit Stream				
Power Supply						
AV_{DD}	Analog supply voltage		4.5	5.5	V	
BV_{DD}	Buffer I/O supply voltage	Low-voltage levels	2.7	3.6	V	
		5V logic levels	4.5	5.5	V	
AI_{DD}	Analog operating supply current	$\text{CLKSEL} = 1$		11.8	16	mA
		$\text{CLKSEL} = 0$		11.4	15.5	mA
BI_{DD}	Buffer I/O operating supply current	$\text{BV}_{\text{DD}} = 3\text{V}$, $\text{CLKOUT} = 10\text{MHz}$			2	mA
		$\text{BV}_{\text{DD}} = 5\text{V}$, $\text{CLKOUT} = 10\text{MHz}$			2	mA
	Power dissipation	$\text{CLKSEL} = 0$		57	77.5	mW
		$\text{CLKSEL} = 1$		59	80	mW

(1) All typical values are at $T_{\text{A}} = +25^{\circ}\text{C}$.

(2) Integral nonlinearity is defined as the maximum deviation of the line through the end points of the specified input range of the transfer curve for $\text{CH x+} = -2\text{V}$ to $+2\text{V}$ at 2.5V , expressed either as the number of LSBs or as a percent of measured input range (4V).

(3) Ensured by design.

(4) Maximum values, including temperature drift, are ensured over the full specified temperature range.

(5) With reduced accuracy, the clock frequency can go from 1MHz to 33MHz .

(6) Applicable for 5.0V nominal supply: $\text{BV}_{\text{DD}} (\text{min}) = 4.5\text{V}$ and $\text{BV}_{\text{DD}} (\text{max}) = 5.5\text{V}$.

(7) Applicable for 3.0V nominal supply: $\text{BV}_{\text{DD}} (\text{min}) = 2.7\text{V}$ and $\text{BV}_{\text{DD}} (\text{max}) = 3.6\text{V}$.

EQUIVALENT INPUT CIRCUIT

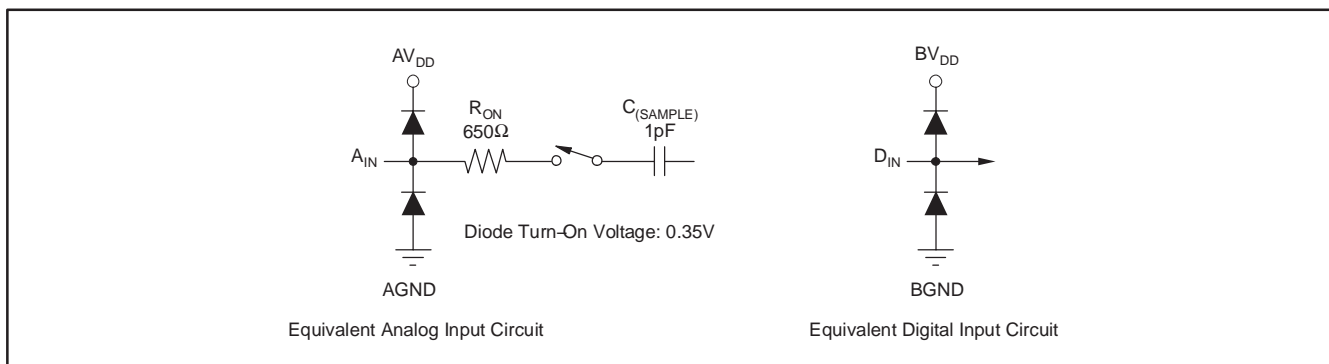

PIN ASSIGNMENT

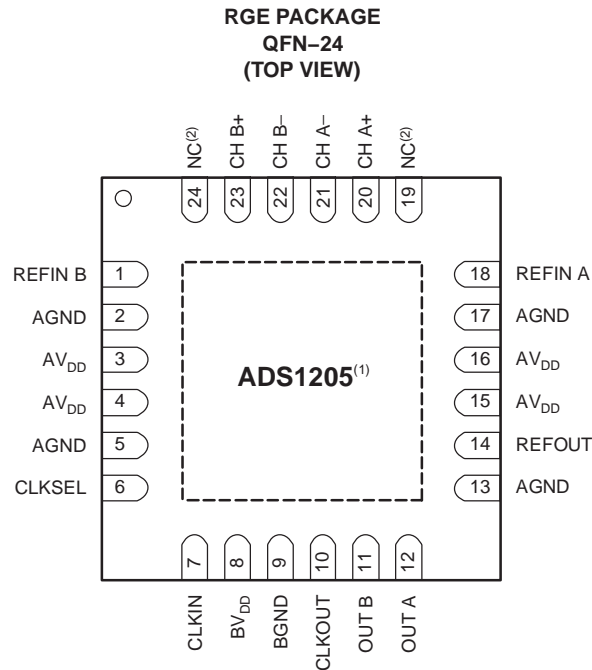

- (1) The thermal pad is internally connected to the substrate. This pad can be connected to the analog ground or left floating. Keep the thermal pad separate from the digital ground, if possible.
- (2) NC = No Connection.

Terminal Functions

TERMINAL NAME	TERMINAL NO.	I/O	DESCRIPTION
REFIN B	1	I	Reference voltage input of channel B: pin for external reference voltage
AGND	2, 5, 13, 17		Analog ground
AV _{DD}	3, 4, 15, 16		Analog power supply; nominal 5V
CLKSEL	6	I	Clock select between internal clock (CLKSEL = 1) or external clock (CLKSEL = 0)
CLKIN	7	I	External clock input
BV _{DD}	8		Digital interface power supply; from 2.7V to 5.5V
BGND	9		Interface ground
CLKOUT	10	O	System clock output
OUT B	11	O	Bit stream from channel B modulator
OUT A	12	O	Bit stream from channel A modulator
REFOUT	14	O	Reference voltage output: output pin of the internal reference source; nominal 2.5V
REFIN A	18	I	Reference voltage input of channel A: pin for external reference voltage
NC	19, 24		No connection; this pin is left unconnected
CH A+	20	I	Analog input of channel A: noninverting input
CH A-	21	I	Analog input of channel A: inverting input
CH B-	22	I	Analog input of channel B: inverting input
CH B+	23	I	Analog input of channel B: noninverting input

PARAMETER MEASUREMENT INFORMATION

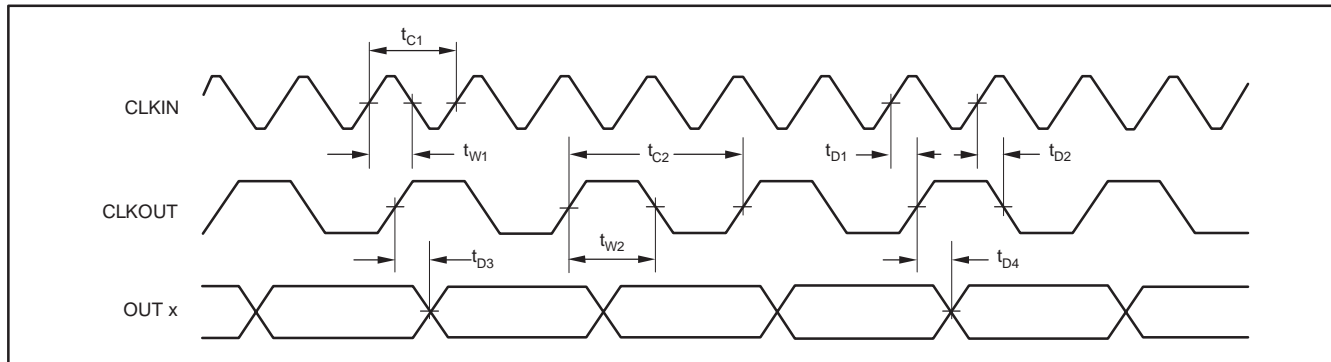

Figure 1. ADS1205 Timing Diagram

TIMING REQUIREMENTS(1)

over recommended operating free-air temperature range at -40°C to $+85^{\circ}\text{C}$, $\text{AV}_{\text{DD}} = 5\text{V}$, and $\text{BV}_{\text{DD}} = 2.7$ to 5V , unless otherwise noted.

PARAMETER		MIN	MAX	UNIT
t_{C1}	CLKIN period: (CLKSEL = 0)	41.6 ⁽²⁾	1000	ns
t_{W1}	CLKIN high time: (CLKSEL = 0)	10	$t_{C1} - 10$	ns
t_{C2}	CLKOUT period using internal oscillator (CLKSEL = 1)	83	125	ns
	CLKOUT period using external clock (CLKSEL = 0)	$2 \times t_{C1}$		ns
t_{W2}	CLKOUT high time	$(t_{C2}/2) - 5$	$(t_{C2}/2) + 5$	ns
t_{D1}	CLKOUT rising edge delay after CLKIN rising edge: (CLKOUT = 0)	0	10	ns
t_{D2}	CLKOUT falling edge delay after CLKIN rising edge: (CLKOUT = 0)	0	10	ns
t_{D3}	Data valid delay after rising edge of CLKOUT (CLKSEL = 1)	$(t_{C2}/4) - 8$	$(t_{C2}/4) + 8$	ns
t_{D4}	Data valid delay after rising edge of CLKOUT (CLKSEL = 0)	$t_{W1} - 3$	$t_{W1} + 7$	ns

(1) All input signals are specified with $t_R = t_F = 5\text{ns}$ (10% to 90% of BV_{DD}) and timed from a voltage level of $(V_{\text{IL}} + V_{\text{IH}})/2$. See Figure 1.

(2) With reduced accuracy, the minimum clock period can go down to 30ns.

TYPICAL CHARACTERISTICS

$V_{DD} = 5V$, $BV_{DD} = 3V$, $CH_{x+} = 0.5V$ to $4.5V$, $CH_{x-} = 2.5V$, $REF_{IN} = REF_{OUT} = \text{internal } +2.5V$, $CLK_{IN} = 20MHz$, and 16-bit Sinc³ filter with decimation by 256, unless otherwise noted.

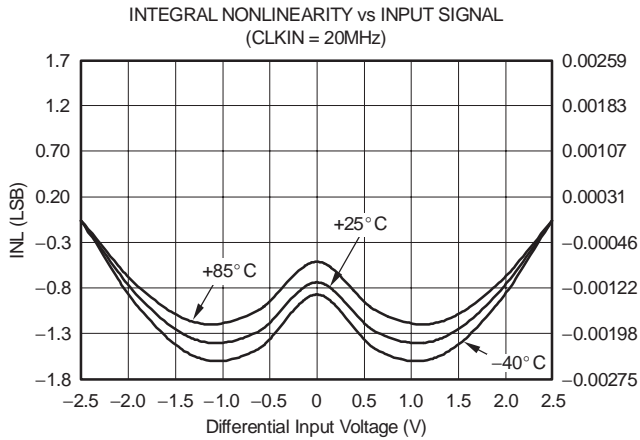

Figure 2

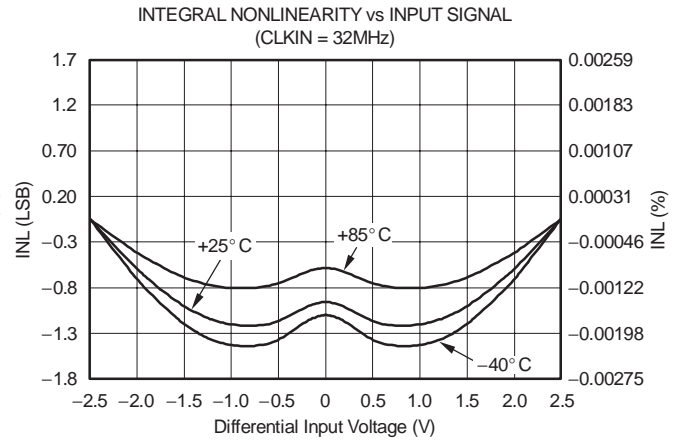

Figure 3

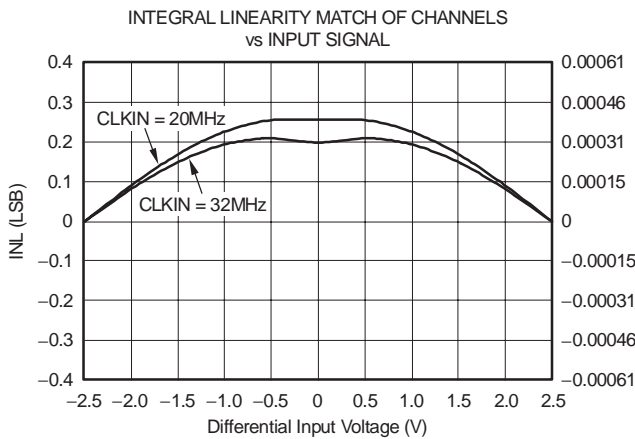

Figure 4

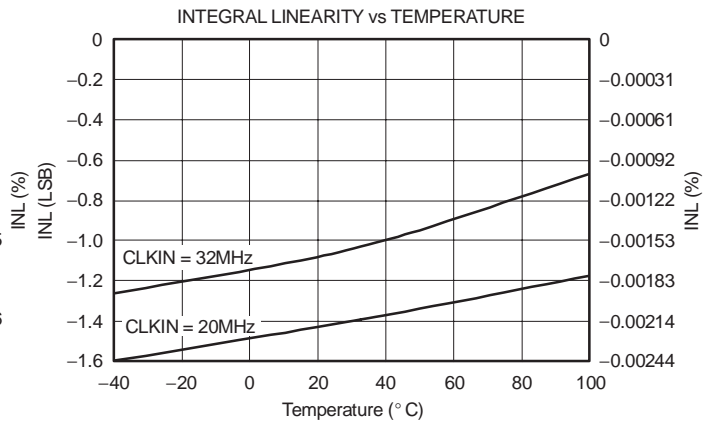

Figure 5

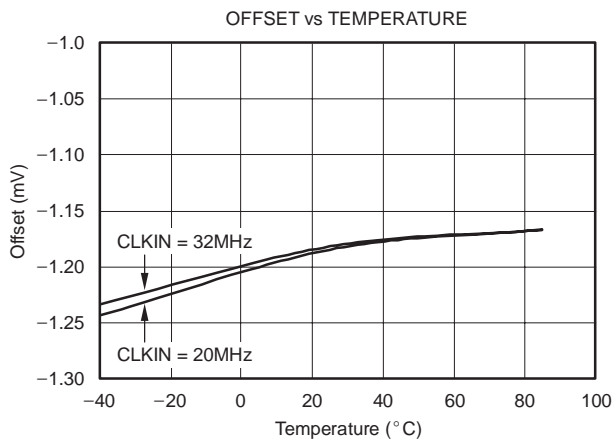

Figure 6

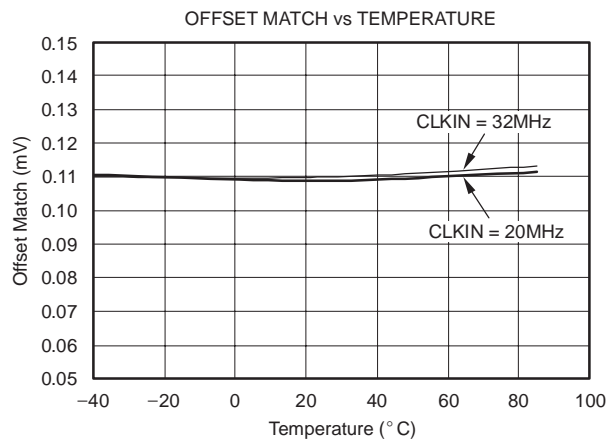

Figure 7

TYPICAL CHARACTERISTICS (continued)

$AV_{DD} = 5V$, $BV_{DD} = 3V$, $CH_{x+} = 0.5V$ to $4.5V$, $CH_{x-} = 2.5V$, $REF_{IN} = REF_{OUT} = \text{internal } +2.5V$, $CLK_{IN} = 20MHz$, and 16-bit Sinc³ filter with decimation by 256, unless otherwise noted.

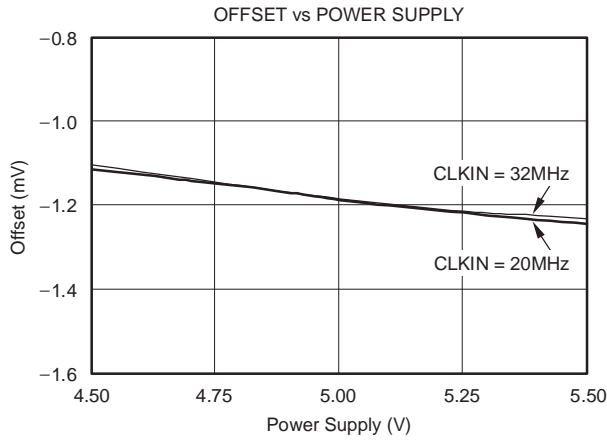

Figure 8

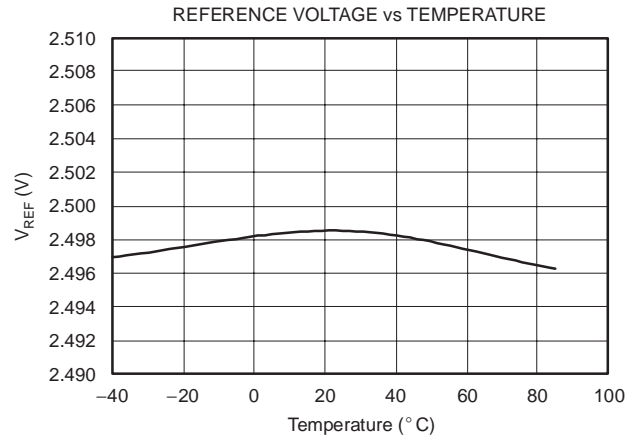

Figure 9

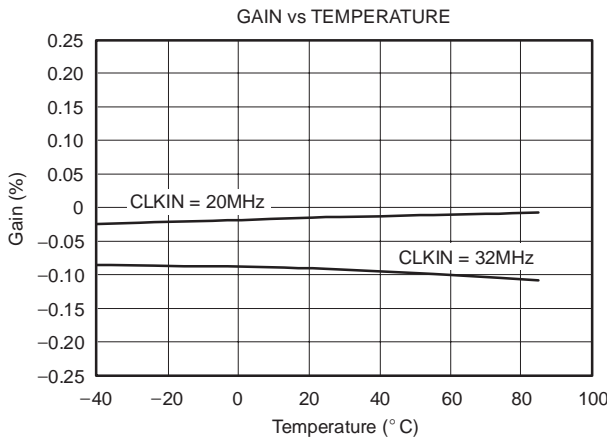

Figure 10

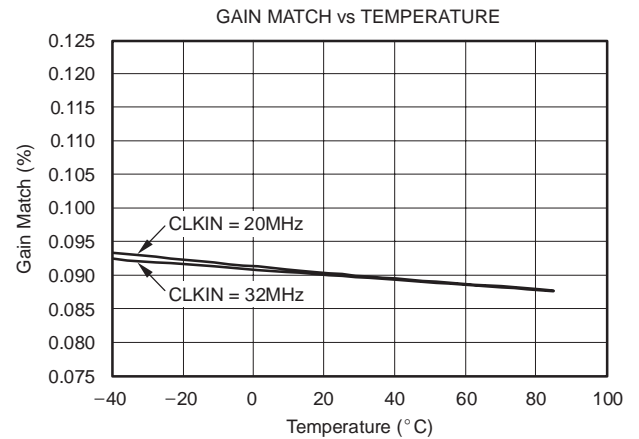

Figure 11

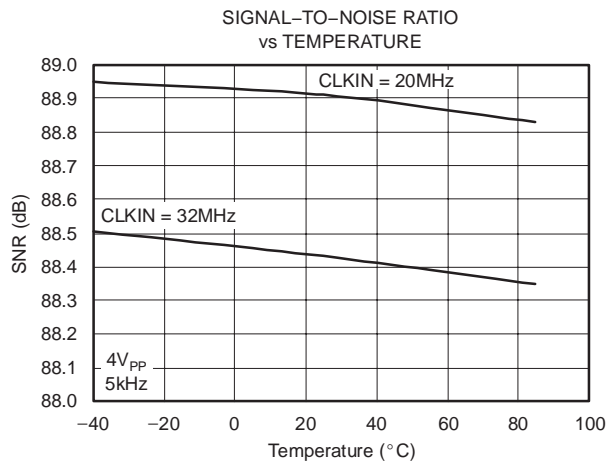

Figure 12

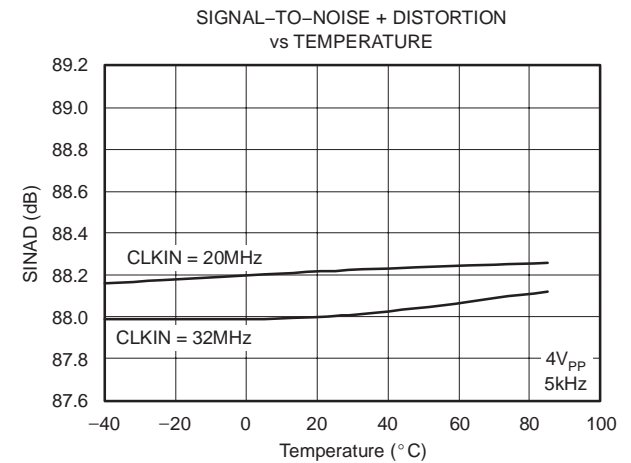

Figure 13

TYPICAL CHARACTERISTICS (continued)

$V_{DD} = 5V$, $BV_{DD} = 3V$, $CH_{x+} = 0.5V$ to $4.5V$, $CH_{x-} = 2.5V$, $REF_{IN} = REF_{OUT} = \text{internal } +2.5V$, $CL_{KIN} = 20MHz$, and 16-bit Sinc³ filter with decimation by 256, unless otherwise noted.

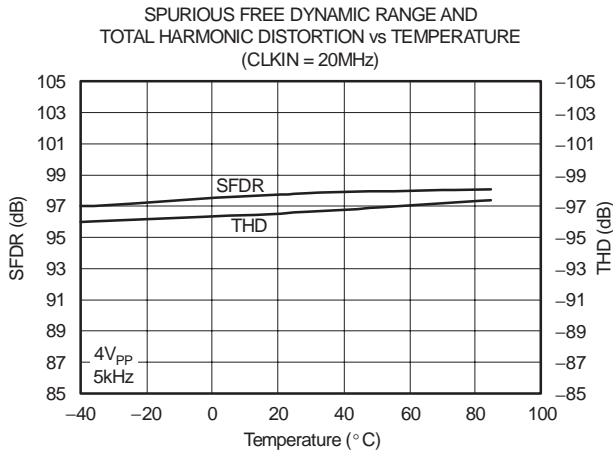

Figure 14

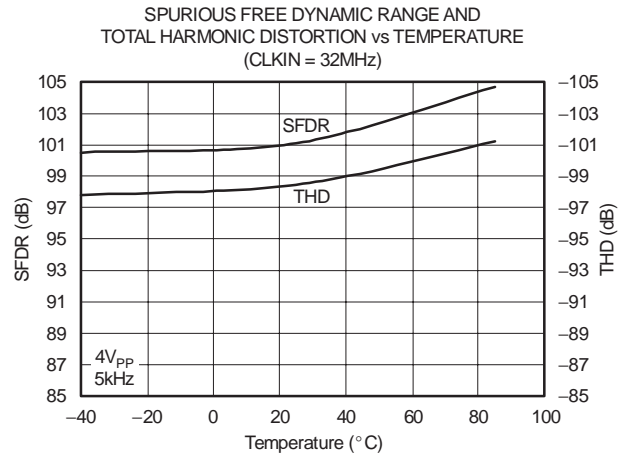

Figure 15

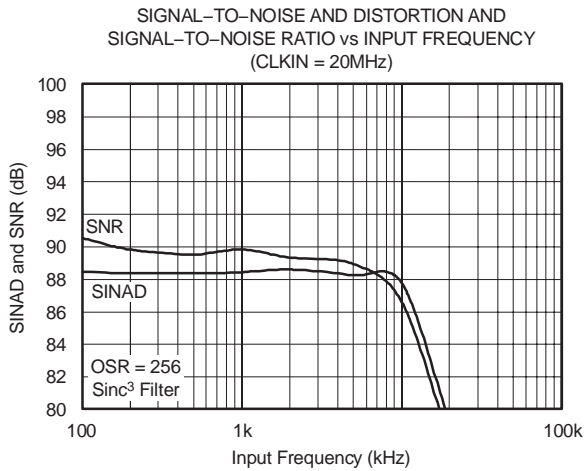

Figure 16

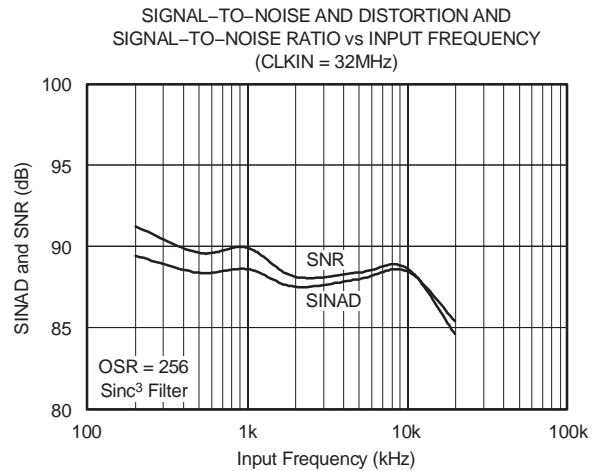

Figure 17

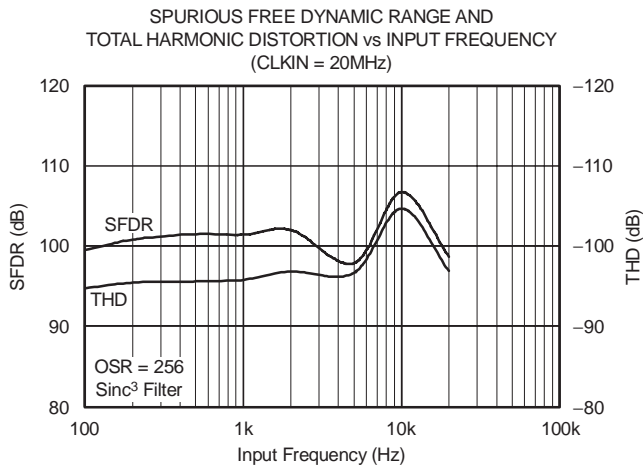

Figure 18

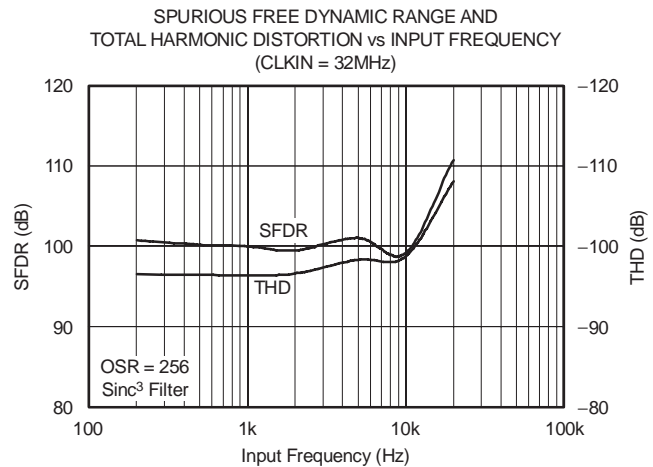
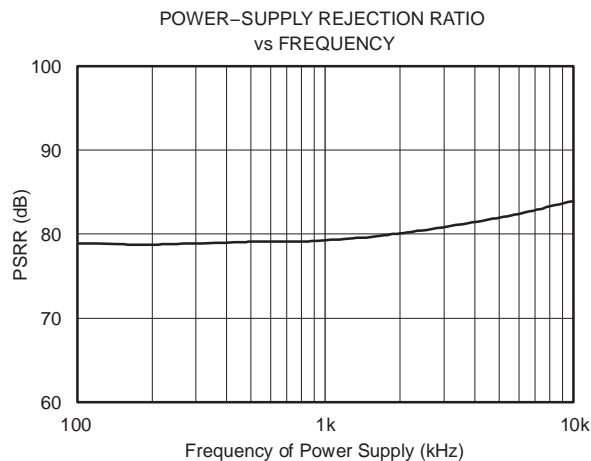
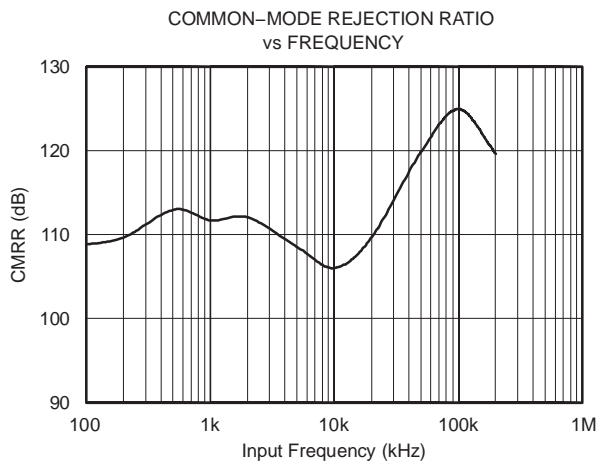
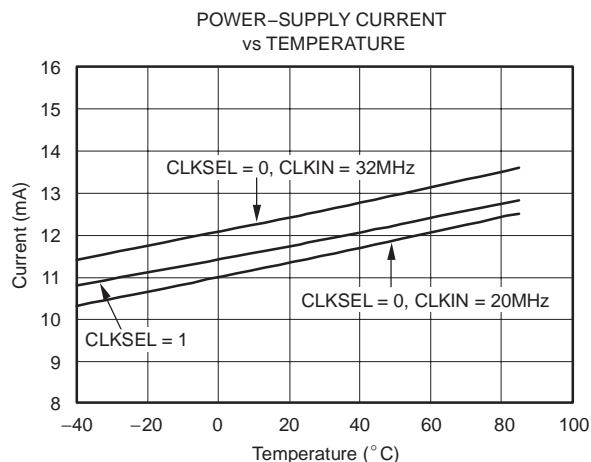
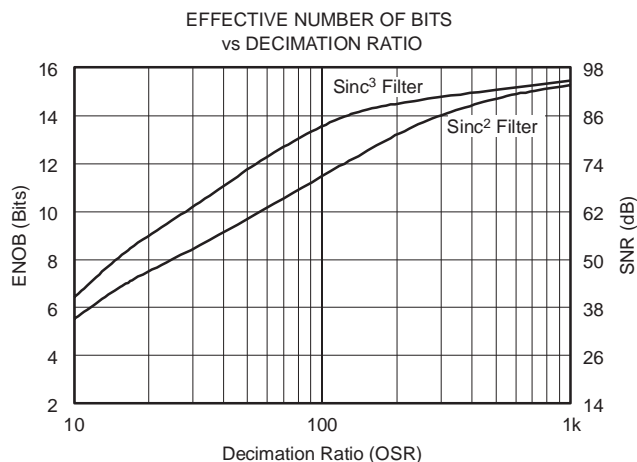
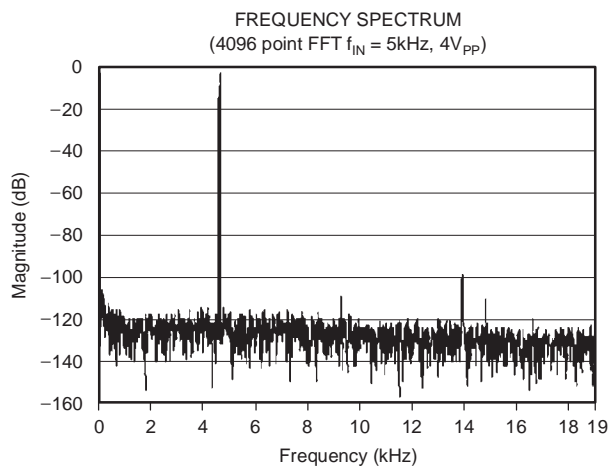
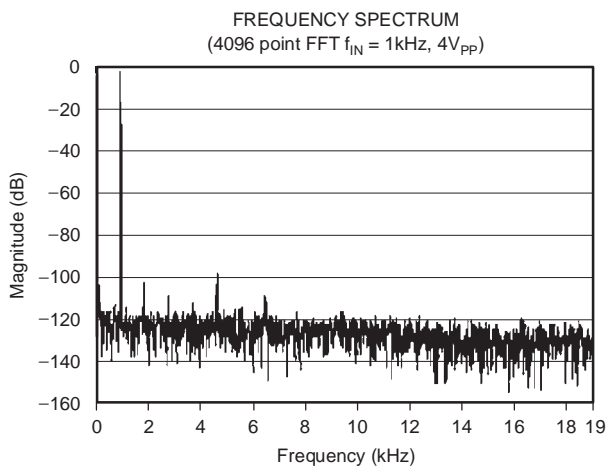

Figure 19

TYPICAL CHARACTERISTICS (continued)

$V_{DD} = 5V$, $BV_{DD} = 3V$, $CH_{x+} = 0.5V$ to $4.5V$, $CH_{x-} = 2.5V$, $REF_{IN} = REF_{OUT} = \text{internal } +2.5V$, $CLK_{IN} = 20MHz$, and 16-bit Sinc³ filter with decimation by 256, unless otherwise noted.



TYPICAL CHARACTERISTICS (continued)

$A_{VDD} = 5V$, $B_{VDD} = 3V$, CH x+ = 0.5V to 4.5V, CH x- = 2.5V, REFIN = REFOUT = internal +2.5V, CLKIN = 20MHz, and 16-bit Sinc³ filter with decimation by 256, unless otherwise noted.

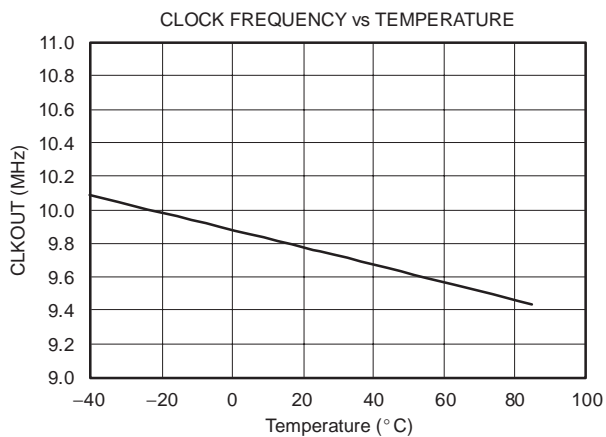

Figure 26

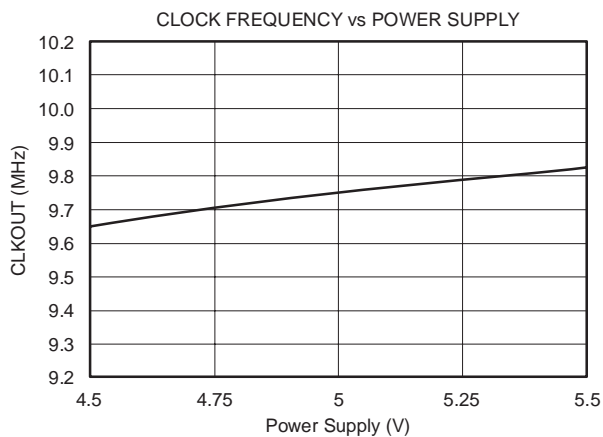

Figure 27

GENERAL DESCRIPTION

The ADS1205 is a two-channel, 2nd-order, CMOS device with two delta-sigma modulators, designed for medium- to high-resolution A/D signal conversions from DC to 39kHz (filter response -3dB) if an oversampling ratio (OSR) of 64 is chosen. The output of the converter (OUT_X) provides a stream of digital ones and zeros. The time average of this serial output is proportional to the analog input voltage.

The modulator shifts the quantization noise to high frequencies. A low-pass digital filter should be used at the output of the delta-sigma modulator. The filter serves two functions. First, it filters out high-frequency noise. Second, the filter converts the 1-bit data stream at a high sampling rate into a higher-bit data word at a lower rate (decimation).

An application-specific integrated circuit (ASIC) or field-programmable gate array (FPGA) could be used to implement the digital filter. Figure 28 and Figure 29 show typical application circuits with the ADS1205 connected to an FPGA or ASIC.

The overall performance (that is, speed and accuracy) depends on the selection of an appropriate OSR and filter type. A higher OSR produces greater output accuracy while operating at a lower refresh rate. Alternatively, a lower OSR produces lower output accuracy, but operates at a higher refresh rate. This system allows flexibility with the digital filter design and is capable of A/D conversion results that have a dynamic range exceeding 98dB with an OSR = 256.

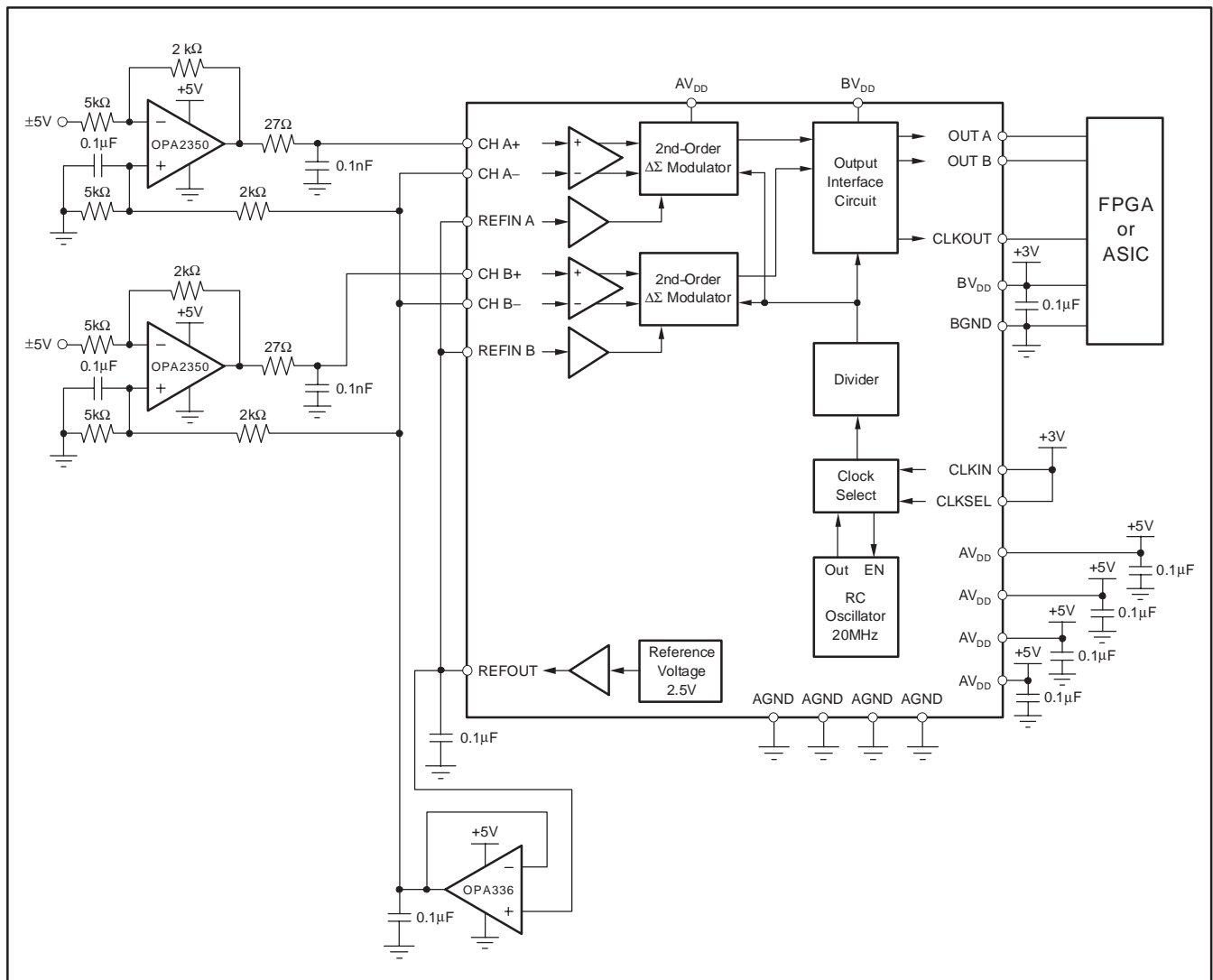

Figure 28. Single-Ended Connection Diagram for the ADS1205 Delta-Sigma Modulator

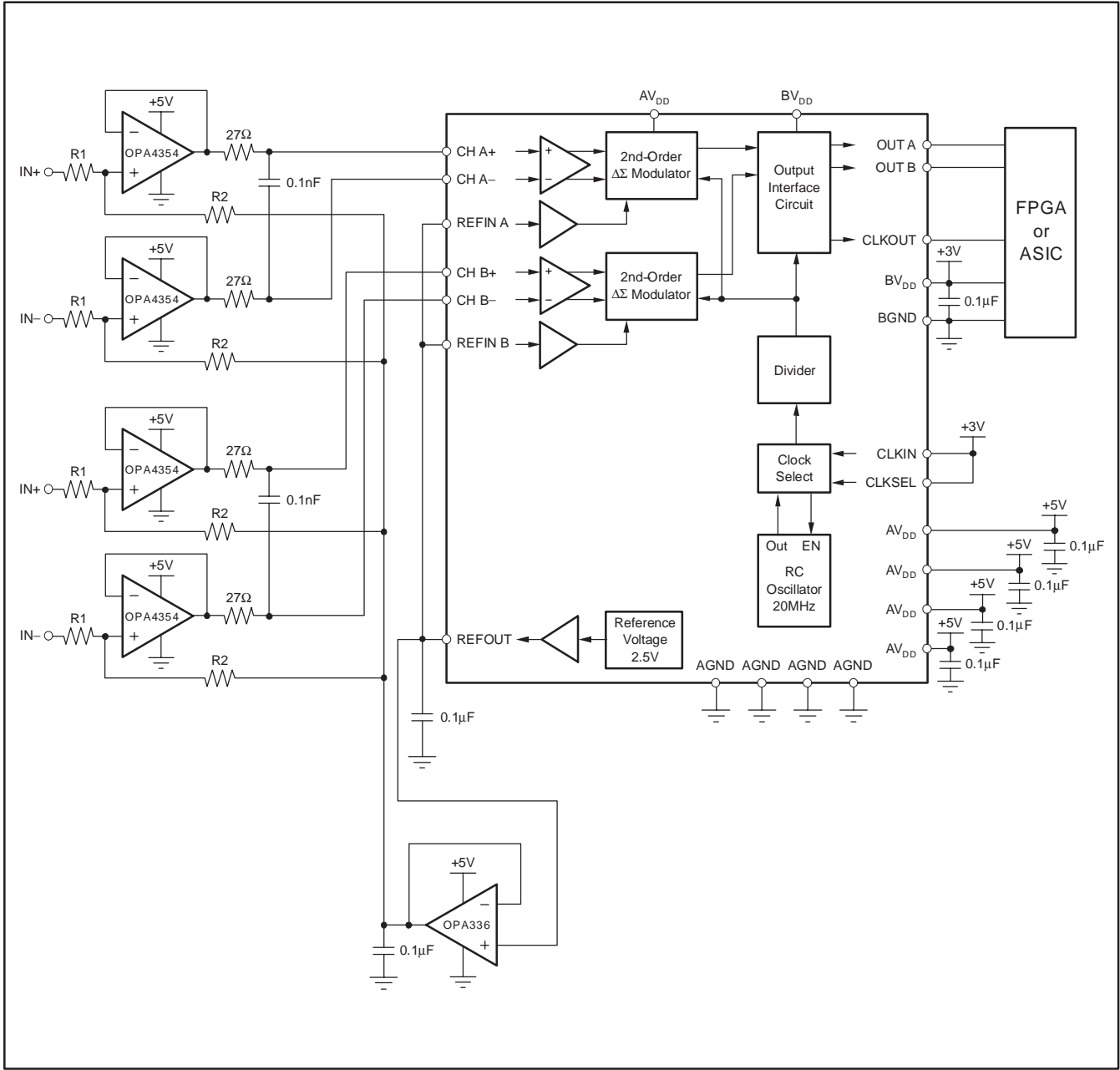

Figure 29. Differential Connection Diagram for the ADS1205 Delta-Sigma Modulator

THEORY OF OPERATION

The differential analog input of the ADS1205 is implemented with a switched-capacitor circuit. This circuit implements a 2nd-order modulator stage, which digitizes the analog input signal into a 1-bit output stream. The clock source can be internal as well as external. Different frequencies for this clock allow for a variety of solutions and signal bandwidths. Every analog input signal is continuously sampled by the modulator and compared to a reference voltage that is applied to the REFINx pin. A digital stream, which accurately represents the analog input voltage over time, appears at the output of the corresponding converter.

ANALOG INPUT STAGE

Analog Input

The topology of the analog inputs of ADS1205 is based on a fully differential switched-capacitor architecture. This input stage provides the mechanism to achieve low system noise, high common-mode rejection (108dB), and excellent power-supply rejection.

The input impedance of the analog input is dependent on the modulator clock frequency (f_{CLK}), which is also the sampling frequency of the modulator. Figure 30 shows the basic input structure of one channel of the ADS1205. The relationship between the input impedance of the ADS1205 and the modulator clock frequency is:

$$Z_{IN} = \frac{100k\Omega}{f_{MOD}/10MHz} \quad (1)$$

The input impedance becomes a consideration in designs where the source impedance of the input signal is high. This high impedance may cause degradation in gain, linearity, and THD. The importance of this effect depends on the desired system performance. There are two

restrictions on the analog input signals, CH x+ and CH x-. If the input voltage exceeds the range ($GND - 0.3V$) to ($V_{DD} + 0.3V$), the input current must be limited to 10mA because the input protection diodes on the front end of the converter will begin to turn on. In addition, the linearity and the noise performance of the device are ensured only when the differential analog voltage resides within $\pm 2V$ (with V_{REF} as a midpoint); however, the FSR input voltage is $\pm 2.5V$.

Modulator

The ADS1205 can be operated in two modes. When $CKLSEL = 1$, the two modulators operate using the internal clock, which is fixed at 20MHz. When $CKLSEL = 0$, the modulators operate using an external clock. In both modes, the clock is divided by two internally and functions as the modulator clock. The frequency of the external clock can vary from 1MHz to 33MHz to adjust for the clock requirements of the application.

The modulator topology is fundamentally a 2nd-order, switched-capacitor, delta-sigma modulator, such as the one conceptualized in Figure 31. The analog input voltage and the output of the 1-bit digital-to-analog converter (DAC) are differentiated, providing analog voltages at X2 and X3. The voltages at X2 and X3 are presented to their individual integrators. The output of these integrators progresses in a negative or positive direction. When the value of the signal at X4 equals the comparator reference voltage, the output of the comparator switches from negative to positive, or positive to negative, depending on its original state. When the output value of the comparator switches from high to low or vice versa, the 1-bit DAC responds on the next clock pulse by changing its analog output voltage at X6, causing the integrators to progress in the opposite direction. The feedback of the modulator to the front end of the integrators forces the value of the integrator output to track the average of the input.

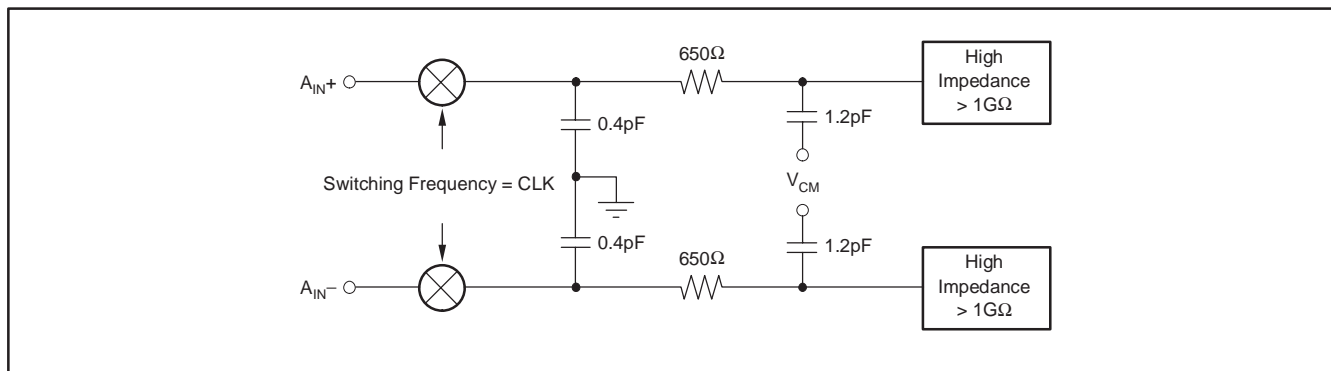

Figure 30. Input Impedance of the ADS1205

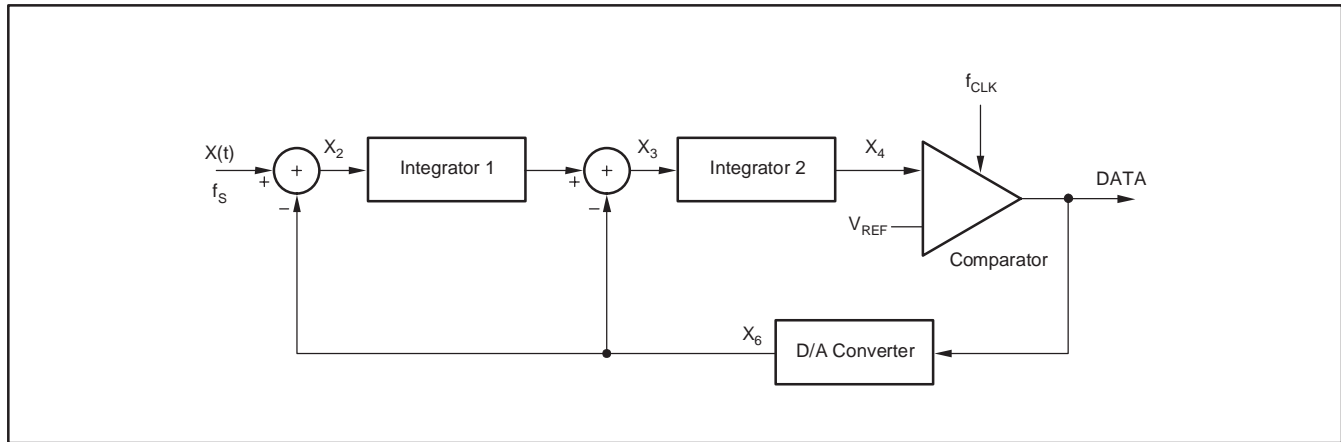

Figure 31. Block Diagram of the 2nd-Order Modulator

DIGITAL OUTPUT

A differential input signal of 0V will ideally produce a stream of ones and zeros that are high 50% of the time and low 50% of the time. A differential input of +2V produces a stream of ones and zeros that are high 80% of the time. A differential input of -2V produces a stream of ones and zeros that are high 20% of the time. The input voltage versus the output modulator signal is shown in Figure 32.

DIGITAL INTERFACE

INTRODUCTION

The analog signal connected to the input of the delta-sigma modulator is converted using the clock signal applied to the modulator. The result of the conversion, or modulation, is generated and sent to the OUTx pin from the delta-sigma modulator. In most applications where a direct connection is realized between the delta-sigma modulator

and an ASIC or FPGA (each with an implemented filter), the two standard signals per modulator (CLKOUT and OUTx) are provided from the modulator. The output clock signal is equal for both modulators. If CLKSEL = 1, CLKIN must always be set either high or low.

MODES OF OPERATION

The system clock of the ADS1205 is 20MHz by default. The system clock can be provided either from the internal 20MHz RC oscillator or from an external clock source. For this purpose, the CLKIN pin is provided; it is controlled by the mode setting, CLKSEL.

The system clock is divided by two for the modulator clock. Therefore, the default clock frequency of the modulator is 10MHz. With a possible external clock range of 1MHz to 33MHz, the modulator operates between 500kHz and 16.5MHz.

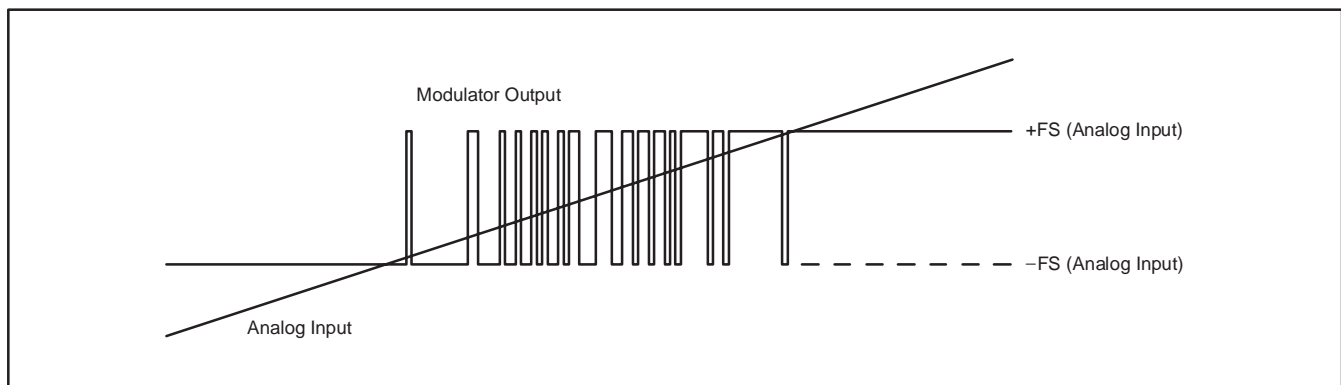

Figure 32. Analog Input vs Modulator Output of the ADS1205

FILTER USAGE

The modulator generates only a bitstream, which does not output a digital word like an A/D converter. In order to output a digital word equivalent to the analog input voltage, the bitstream must be processed by a digital filter.

A very simple filter, built with minimal effort and hardware, is the Sinc³ filter:

$$H(z) = \left(\frac{1 - z^{-OSR}}{1 - z^{-1}} \right)^3 \quad (2)$$

This filter provides the best output performance at the lowest hardware size (for example, a count of digital gates). For oversampling ratios in the range of 16 to 256, this is a good choice. All the characterizations in the data sheet are also done using a Sinc³ filter with an oversampling ratio of OSR = 256 and an output word length of 16 bits.

In a Sinc³ filter response (shown in Figure 33 and Figure 34), the location of the first notch occurs at the frequency of output data rate $f_{DATA} = f_{CLK}/OSR$. The -3dB point is located at half the Nyquist frequency or $f_{DATA}/4$. For some applications, it may be necessary to use another filter type for better frequency response.

This performance can be improved, for example, by a cascaded filter structure. The first decimation stage can be a Sinc³ filter with a low OSR and the second stage a high-order filter.

For more information, see application note SBAA094, *Combining the ADS1202 with an FPGA Digital Filter for Current Measurement in Motor Control Applications*, available for download at www.ti.com.

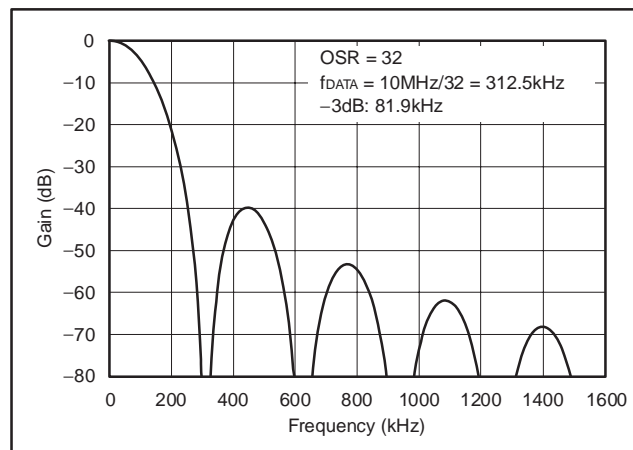

Figure 33. Frequency Response of Sinc³ Filter

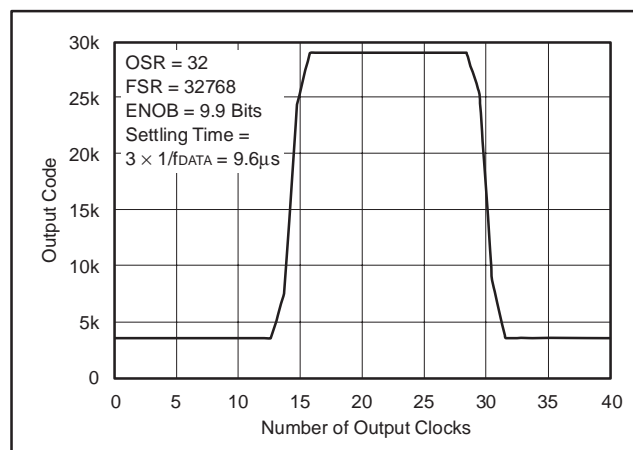

Figure 34. Pulse Response of Sinc³ Filter ($f_{MOD} = 10\text{MHz}$)

The effective number of bits (ENOB) can be used to compare the performance of ADCs and delta-sigma modulators. Figure 35 shows the ENOB of the ADS1205 with different filter types. In this data sheet, the ENOB is calculated from the SNR:

$$\text{SNR} = 1.76\text{dB} + 6.02\text{dB} \times \text{ENOB} \tag{3}$$

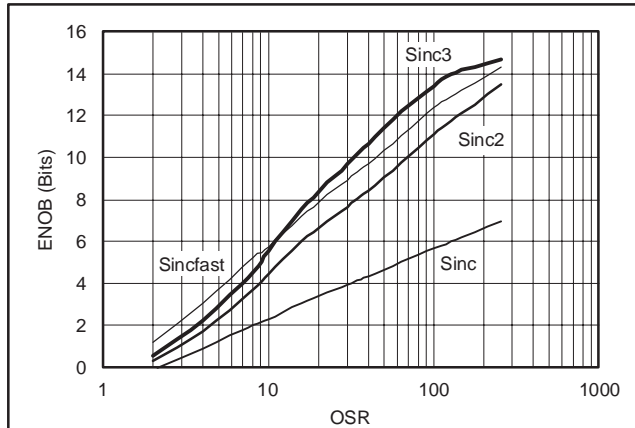

Figure 35. Measured ENOB vs OSR

In motor control applications, a very fast response time for overcurrent detection is required. There is a constraint between 1µs and 5µs with 3 bits to 7 bits resolution. The time for full settling is dependent on the filter order. Therefore, the full settling of the Sinc³ filter needs three data clocks and the Sinc² filter needs two data clocks. The data clock is equal to the modulator clock divided by the OSR. For overcurrent protection,

filter types other than Sinc³ might be a better choice. A simple example is a Sinc² filter. The Sincfast is a modified Sinc² filter:

$$H(z) = \left(\frac{1 - z^{-\text{OSR}}}{1 - z^{-1}} \right)^2 (1 + z^{-2 \times \text{OSR}}) \tag{4}$$

Figure 36 compares the settling time of different filter types operating with a 10MHz modulator clock.

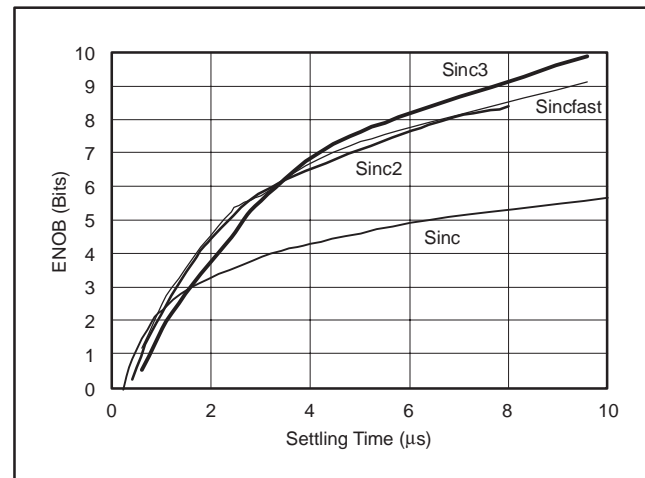

Figure 36. Measured ENOB vs Settling Time

For more information, see application note SBAA094, *Combining the ADS1202 with an FPGA Digital Filter for Current Measurement in Motor Control Applications*, available for download at www.ti.com.

LAYOUT CONSIDERATIONS

POWER SUPPLIES

An applied external digital filter rejects high-frequency noise. PSRR and CMRR improve at higher frequencies because the digital filter suppresses high-frequency noise. However, the suppression of the filter is not infinite, so high-frequency noise still influences the conversion result.

Inputs to the ADS1205, such as CH x+, CH x–, and CLKIN, should not be present before the power supply is on. Violating this condition could cause latch-up. If these signals are present before the supply is on, series resistors should be used to limit the input current to a maximum of 10mA. Experimentation may be the best way to determine the appropriate connection between the ADS1205 and different power supplies.

GROUNDING

Analog and digital sections of the design must be carefully and cleanly partitioned. Each section should have its own ground plane with no overlap between them. Do not join the ground planes; instead, connect the two with a moderate signal trace underneath the converter. However, for different applications with DSPs and switching power supplies, this process might be different.

For multiple converters, connect the two ground planes as close as possible to one central location for all of the converters. In some cases, experimentation may be required to find the best point to connect the two planes together.

DECOUPLING

Good decoupling practices must be used for the ADS1205 and for all components in the design. All decoupling capacitors, specifically the 0.1 μ F ceramic capacitors, must be placed as close as possible to the pin being decoupled. A 1 μ F and 10 μ F capacitor, in parallel with the 0.1 μ F ceramic capacitor, can be used to decouple AV_{DD} to AGND as well as BV_{DD} to BGND. At least one 0.1 μ F ceramic capacitor must be used to decouple every AV_{DD} to AGND and BV_{DD} to BGND, as well as for the digital supply on each digital component.

The digital supply sets the I/O voltage for the interface and can be set within a range of 2.7V to 5.5V.

In cases where both the analog and digital I/O supplies share the same supply source, an RC filter of 10 Ω and 0.1 μ F can be used to help reduce the noise in the analog supply.

Revision History

DATE	REV	PAGE	SECTION	DESCRIPTION
8/06	B	6	Pin Assignment	Added Note 1 to QFN package.

NOTE: Page numbers for previous revisions may differ from page numbers in the current version.

PACKAGING INFORMATION

Orderable Device	Status ⁽¹⁾	Package Type	Package Drawing	Pins	Package Qty	Eco Plan ⁽²⁾	Lead/Ball Finish	MSL Peak Temp ⁽³⁾
ADS1205IRGER	ACTIVE	QFN	RGE	24	3000	Green (RoHS & no Sb/Br)	CU NIPDAU	Level-2-260C-1 YEAR
ADS1205IRGERG4	ACTIVE	QFN	RGE	24	3000	Green (RoHS & no Sb/Br)	CU NIPDAU	Level-2-260C-1 YEAR
ADS1205IRGET	ACTIVE	QFN	RGE	24	250	Green (RoHS & no Sb/Br)	CU NIPDAU	Level-2-260C-1 YEAR
ADS1205IRGETG4	ACTIVE	QFN	RGE	24	250	Green (RoHS & no Sb/Br)	CU NIPDAU	Level-2-260C-1 YEAR

⁽¹⁾ The marketing status values are defined as follows:

ACTIVE: Product device recommended for new designs.

LIFEBUY: TI has announced that the device will be discontinued, and a lifetime-buy period is in effect.

NRND: Not recommended for new designs. Device is in production to support existing customers, but TI does not recommend using this part in a new design.

PREVIEW: Device has been announced but is not in production. Samples may or may not be available.

OBSOLETE: TI has discontinued the production of the device.

⁽²⁾ Eco Plan - The planned eco-friendly classification: Pb-Free (RoHS), Pb-Free (RoHS Exempt), or Green (RoHS & no Sb/Br) - please check <http://www.ti.com/productcontent> for the latest availability information and additional product content details.

TBD: The Pb-Free/Green conversion plan has not been defined.

Pb-Free (RoHS): TI's terms "Lead-Free" or "Pb-Free" mean semiconductor products that are compatible with the current RoHS requirements for all 6 substances, including the requirement that lead not exceed 0.1% by weight in homogeneous materials. Where designed to be soldered at high temperatures, TI Pb-Free products are suitable for use in specified lead-free processes.

Pb-Free (RoHS Exempt): This component has a RoHS exemption for either 1) lead-based flip-chip solder bumps used between the die and package, or 2) lead-based die adhesive used between the die and leadframe. The component is otherwise considered Pb-Free (RoHS compatible) as defined above.

Green (RoHS & no Sb/Br): TI defines "Green" to mean Pb-Free (RoHS compatible), and free of Bromine (Br) and Antimony (Sb) based flame retardants (Br or Sb do not exceed 0.1% by weight in homogeneous material)

⁽³⁾ MSL, Peak Temp. -- The Moisture Sensitivity Level rating according to the JEDEC industry standard classifications, and peak solder temperature.

Important Information and Disclaimer:The information provided on this page represents TI's knowledge and belief as of the date that it is provided. TI bases its knowledge and belief on information provided by third parties, and makes no representation or warranty as to the accuracy of such information. Efforts are underway to better integrate information from third parties. TI has taken and continues to take reasonable steps to provide representative and accurate information but may not have conducted destructive testing or chemical analysis on incoming materials and chemicals. TI and TI suppliers consider certain information to be proprietary, and thus CAS numbers and other limited information may not be available for release.

In no event shall TI's liability arising out of such information exceed the total purchase price of the TI part(s) at issue in this document sold by TI to Customer on an annual basis.

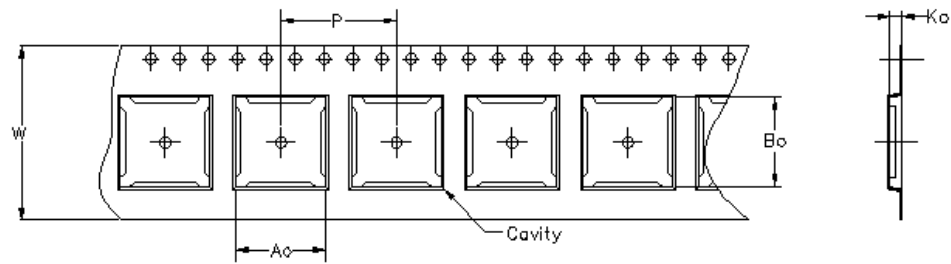

Carrier tape design is defined largely by the component length, width, and thickness.

A_o = Dimension designed to accommodate the component width.
B_o = Dimension designed to accommodate the component length.
K_o = Dimension designed to accommodate the component thickness.
W = Overall width of the carrier tape.
P = Pitch between successive cavity centers.

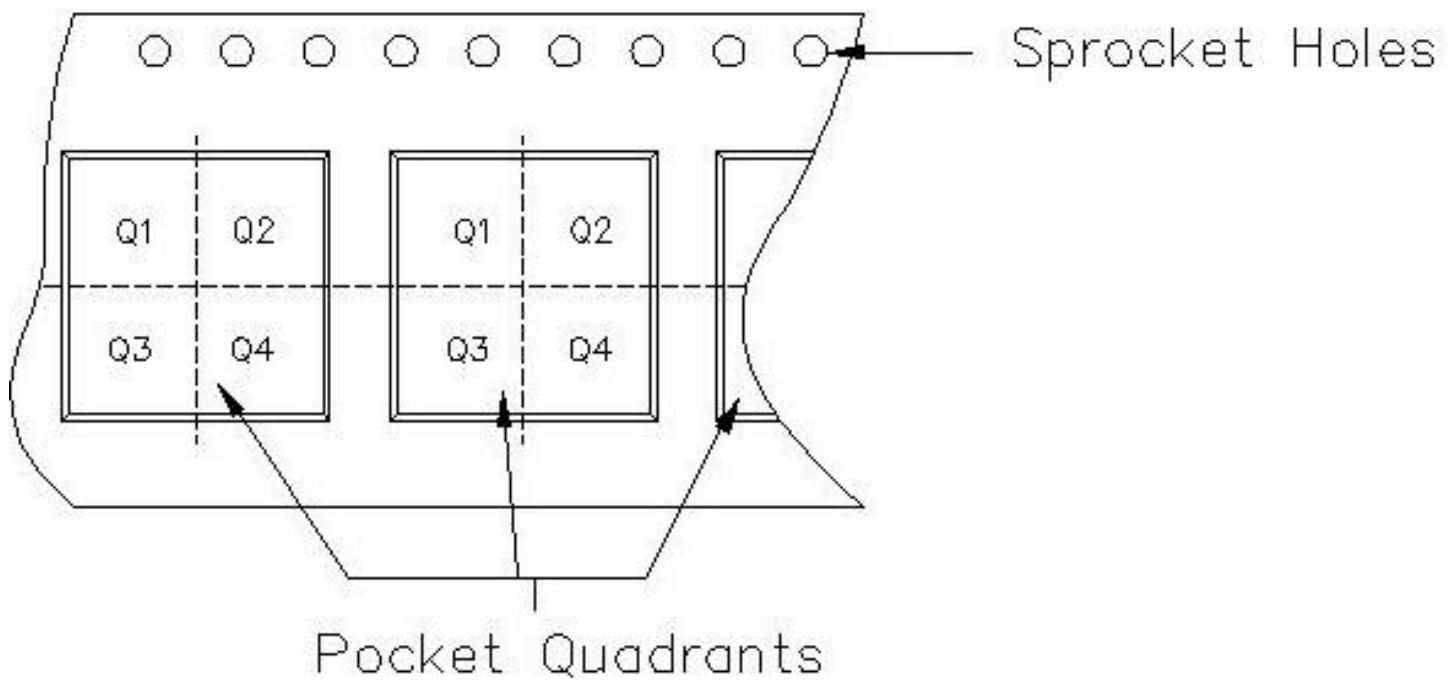

TAPE AND REEL INFORMATION

Device	Package	Pins	Site	Reel Diameter (mm)	Reel Width (mm)	A0 (mm)	B0 (mm)	K0 (mm)	P1 (mm)	W (mm)	Pin1 Quadrant
ADS1205IRGER	RGE	24	TAI	330	12	4.3	4.3	1.5	8	12	Q2
ADS1205IRGET	RGE	24	TAI	330	12	4.3	4.3	1.5	8	12	Q2

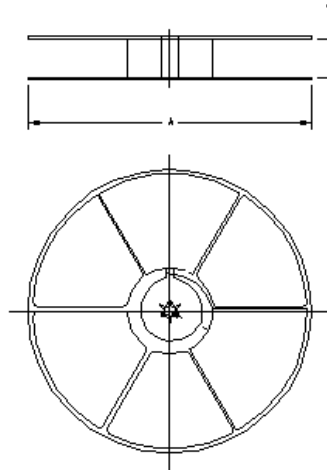

TAPE AND REEL BOX INFORMATION

Device	Package	Pins	Site	Length (mm)	Width (mm)	Height (mm)
ADS1205IRGER	RGE	24	TAI	407.0	336.6	97.0
ADS1205IRGET	RGE	24	TAI	407.0	336.6	97.0

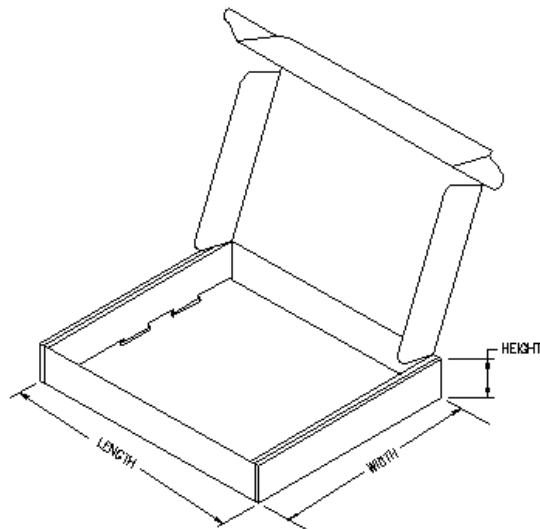

RGE (S-PQFP-N24) PIN 1 OPTION PLASTIC QUAD FLATPACK

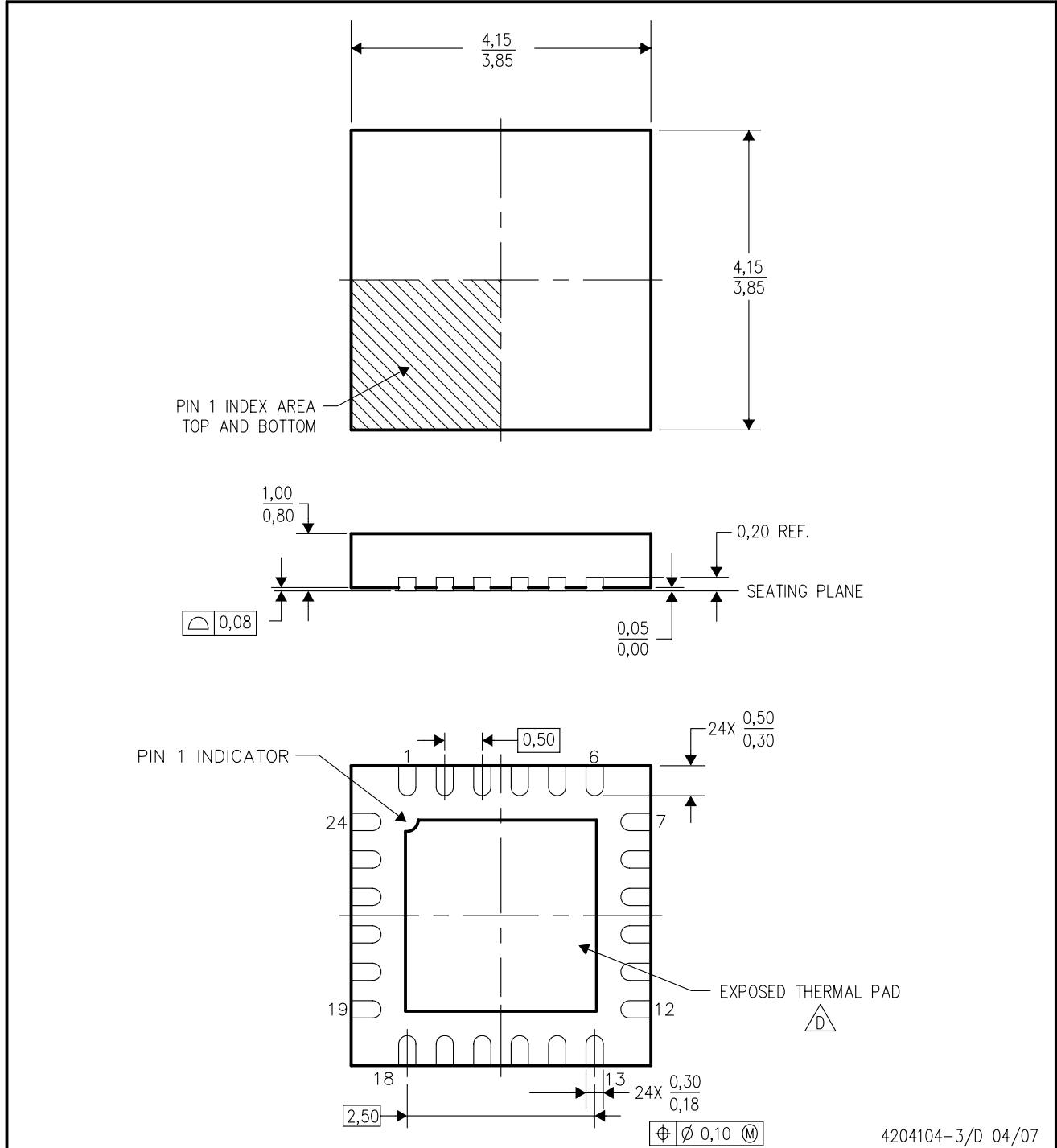

- NOTES:
- A. All linear dimensions are in millimeters. Dimensioning and tolerancing per ASME Y14.5M-1994.
 - B. This drawing is subject to change without notice.
 - C. Quad Flatpack, No-Leads (QFN) package configuration.
 - D. The package thermal pad must be soldered to the board for thermal and mechanical performance. See the Product Data Sheet for details regarding the exposed thermal pad dimensions.
 - E. Falls within JEDEC MO-220.

THERMAL INFORMATION

This package incorporates an exposed thermal pad that is designed to be attached directly to an external heatsink. The thermal pad must be soldered directly to the printed circuit board (PCB). After soldering, the PCB can be used as a heatsink. In addition, through the use of thermal vias, the thermal pad can be attached directly to the appropriate copper plane shown in the electrical schematic for the device, or alternatively, can be attached to a special heatsink structure designed into the PCB. This design optimizes the heat transfer from the integrated circuit (IC).

For information on the Quad Flatpack No-Lead (QFN) package and its advantages, refer to Application Report, Quad Flatpack No-Lead Logic Packages, Texas Instruments Literature No. SCBA017. This document is available at www.ti.com.

The exposed thermal pad dimensions for this package are shown in the following illustration.

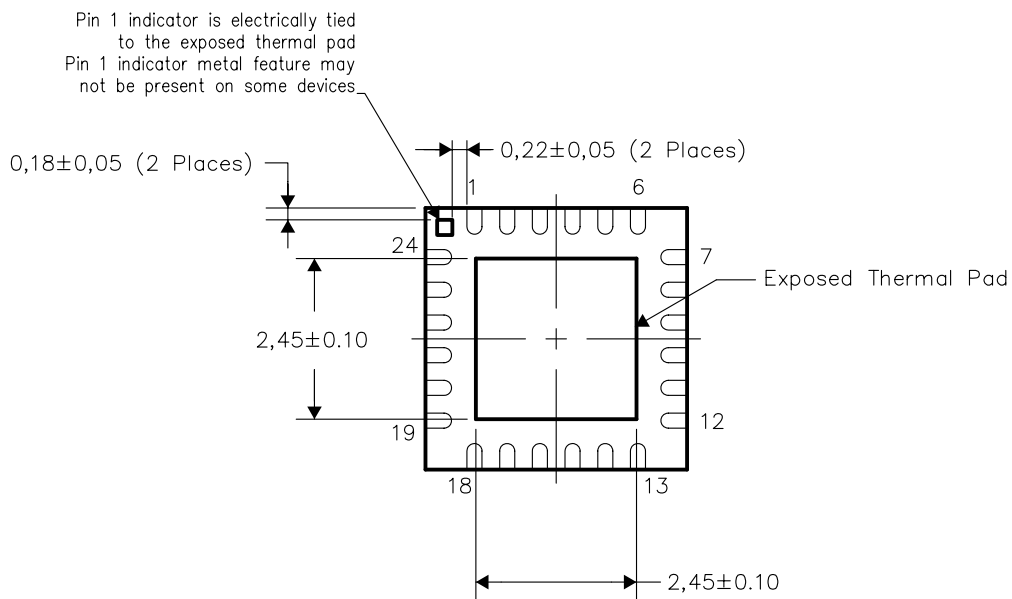

Bottom View

NOTE: All linear dimensions are in millimeters

Exposed Thermal Pad Dimensions

RGE (S-PQFP-N24)

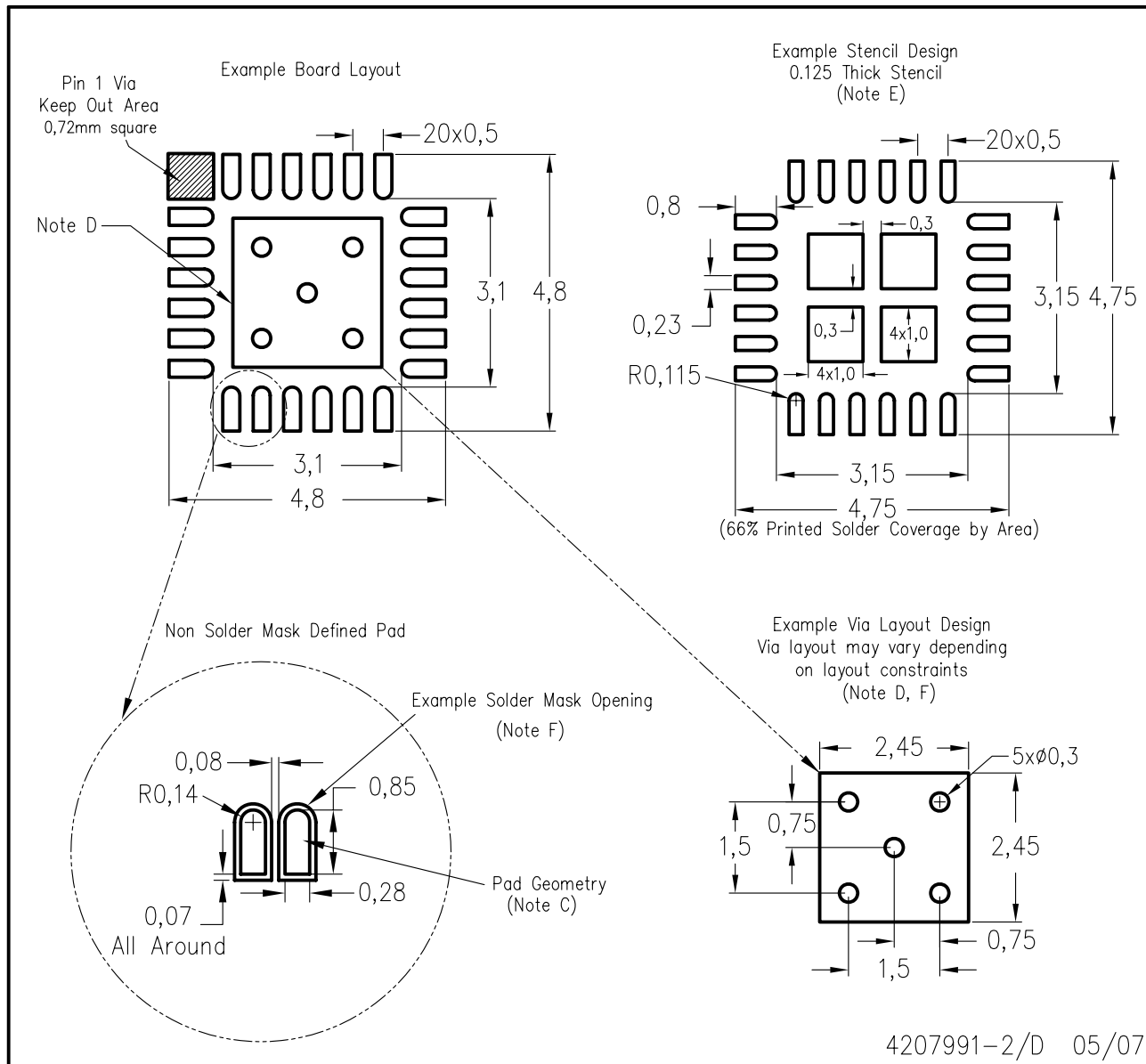

- NOTES:
- A. All linear dimensions are in millimeters.
 - B. This drawing is subject to change without notice.
 - C. Publication IPC-7351 is recommended for alternate designs.
 - D. This package is designed to be soldered to a thermal pad on the board. Refer to Application Note, Quad Flat-Pack Packages, Texas Instruments Literature No. SCBA017, SLUA271, and also the Product Data Sheets for specific thermal information, via requirements, and recommended board layout. These documents are available at www.ti.com <<http://www.ti.com>>.
 - E. Laser cutting apertures with trapezoidal walls and also rounding corners will offer better paste release. Customers should contact their board assembly site for stencil design recommendations. Refer to IPC 7525 for stencil design considerations.
 - F. Customers should contact their board fabrication site for recommended solder mask tolerances and via tenting recommendations for vias placed in the thermal pad.

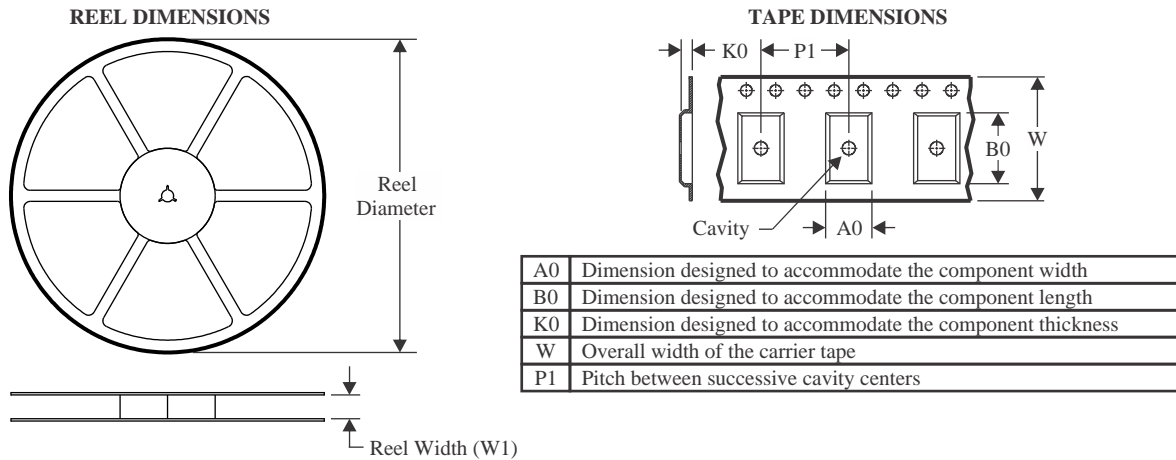
TAPE AND REEL INFORMATION

QUADRANT ASSIGNMENTS FOR PIN 1 ORIENTATION IN TAPE

*All dimensions are nominal

Device	Package Type	Package Drawing	Pins	SPQ	Reel Diameter (mm)	Reel Width W1 (mm)	A0 (mm)	B0 (mm)	K0 (mm)	P1 (mm)	W (mm)	Pin1 Quadrant
ADS1205IRGER	VQFN	RGE	24	3000	330.0	12.4	4.3	4.3	1.5	8.0	12.0	Q2
ADS1205IRGET	VQFN	RGE	24	250	180.0	12.4	4.3	4.3	1.5	8.0	12.0	Q2

TAPE AND REEL BOX DIMENSIONS

*All dimensions are nominal

Device	Package Type	Package Drawing	Pins	SPQ	Length (mm)	Width (mm)	Height (mm)
ADS1205IRGER	VQFN	RGE	24	3000	350.0	350.0	43.0
ADS1205IRGET	VQFN	RGE	24	250	210.0	185.0	35.0

IMPORTANT NOTICE AND DISCLAIMER

TI PROVIDES TECHNICAL AND RELIABILITY DATA (INCLUDING DATASHEETS), DESIGN RESOURCES (INCLUDING REFERENCE DESIGNS), APPLICATION OR OTHER DESIGN ADVICE, WEB TOOLS, SAFETY INFORMATION, AND OTHER RESOURCES "AS IS" AND WITH ALL FAULTS, AND DISCLAIMS ALL WARRANTIES, EXPRESS AND IMPLIED, INCLUDING WITHOUT LIMITATION ANY IMPLIED WARRANTIES OF MERCHANTABILITY, FITNESS FOR A PARTICULAR PURPOSE OR NON-INFRINGEMENT OF THIRD PARTY INTELLECTUAL PROPERTY RIGHTS.

These resources are intended for skilled developers designing with TI products. You are solely responsible for (1) selecting the appropriate TI products for your application, (2) designing, validating and testing your application, and (3) ensuring your application meets applicable standards, and any other safety, security, regulatory or other requirements.

These resources are subject to change without notice. TI grants you permission to use these resources only for development of an application that uses the TI products described in the resource. Other reproduction and display of these resources is prohibited. No license is granted to any other TI intellectual property right or to any third party intellectual property right. TI disclaims responsibility for, and you fully indemnify TI and its representatives against any claims, damages, costs, losses, and liabilities arising out of your use of these resources.

TI's products are provided subject to [TI's Terms of Sale](#), [TI's General Quality Guidelines](#), or other applicable terms available either on ti.com or provided in conjunction with such TI products. TI's provision of these resources does not expand or otherwise alter TI's applicable warranties or warranty disclaimers for TI products. Unless TI explicitly designates a product as custom or customer-specified, TI products are standard, catalog, general purpose devices.

TI objects to and rejects any additional or different terms you may propose.

Copyright © 2026, Texas Instruments Incorporated

Last updated 10/2025