

## ATL43x 2.5V Low Iq Adjustable Precision Shunt Regulator

### 1 Features

- Adjustable Regulated Output of 2.5V to 36V
- Very-Low Operating Current
  - $I_{KA(min)} = 35\mu A$  (Maximum)
  - $I_{REF} = 150nA$  (Maximum)
- Internally Compensated for Stability
  - Stable With No Capacitive Load
- Reference Voltage Tolerances at 25°C
  - 0.5% for B Grade
  - 1% for A Grade
- Typical Temperature Drift
  - 5mV (–40°C to +85°C); I Version
  - 6mV (–40°C to +125°C); Q Version
- Extended Cathode Current Range  
35μA to 100mA
- Low Output Impedance of 0.3Ω (Maximum)

### 2 Applications

- Secondary Side Regulation in Flyback SMPSs
- Industrial, Computing, Consumer, and Portables
- Adjustable Voltage and Current Referencing
- Power Management
- Power Isolation
- Zener Replacement

### 3 Description

The ATL431 and ATL432 are three-terminal adjustable shunt regulators, with specified thermal stability over applicable automotive, commercial, and industrial temperature ranges. The output voltage can be set to any value between  $V_{ref}$  (approximately 2.5V) and 36V, with two external resistors. These devices have a typical output impedance of 0.05Ω. Active output circuitry provides a very sharp turn-on characteristic, making these devices excellent replacements for Zener diodes in many applications, such as onboard regulation, adjustable power supplies, and switching power supplies.

The ATL43x has > 20x improvement cathode current range over its TL43x predecessor. It also is stable with a wider range of load capacitance types and values.

ATL431 and ATL432 are the exact same parts but with different pinouts and order numbers. The ATL43x is offered in two grades, with initial tolerances (at 25°C) of 0.5%, 1%, for the B and A grade, respectively. In addition, low output drift vs temperature ensures consistent voltage regulation over the entire temperature range.

The ATL43xxI devices are characterized for operation from –40°C to +85°C, and the ATL43xxQ devices are characterized for operation from –40°C to +125°C.

#### Device Information

PART NUMBER	PACKAGE <sup>(1)</sup>	BODY SIZE (NOM) <sup>(2)</sup>
ATL431	SOT (3)	2.90mm × 1.60mm
ATL432		

- For all available packages, see the orderable addendum at the end of the data sheet.
- The package size (length × width) is a nominal value and includes pins, where applicable.

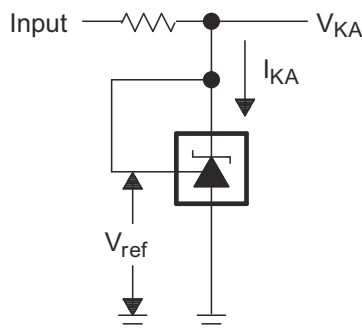

Copyright © 2017, Texas Instruments Incorporated

Simplified Schematic

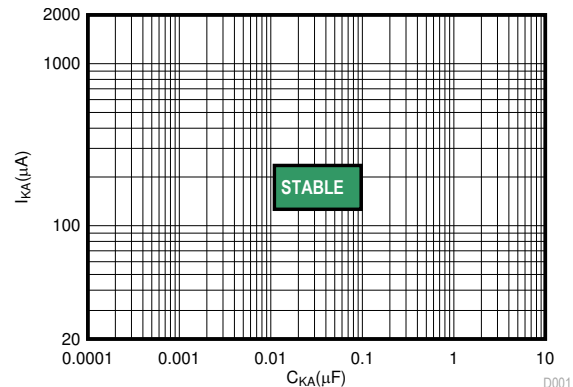

Stability Region for  $V_{KA} = 15V$



## Table of Contents

<b>1 Features</b> .....	1	7.4 Device Functional Modes.....	12
<b>2 Applications</b> .....	1	<b>8 Application and Implementation</b> .....	13
<b>3 Description</b> .....	1	8.1 Application Information.....	13
<b>4 Pin Configuration and Functions</b> .....	3	8.2 Typical Applications.....	14
<b>5 Specifications</b> .....	3	<b>9 Power Supply Recommendations</b> .....	19
5.1 Absolute Maximum Ratings.....	3	<b>10 Layout</b> .....	19
5.2 ESD Ratings.....	3	10.1 Layout Guidelines.....	19
5.3 Recommended Operating Conditions.....	3	10.2 Layout Example.....	19
5.4 Thermal Information.....	4	<b>11 Device and Documentation Support</b> .....	20
5.5 Electrical Characteristics, ATL431Ax, ATL432Ax.....	4	11.1 Receiving Notification of Documentation Updates..	20
5.6 Electrical Characteristics, ATL431Bx, ATL432Bx.....	4	11.2 Support Resources.....	20
5.7 Typical Characteristics.....	5	11.3 Trademarks.....	20
<b>6 Parameter Measurement Information</b> .....	9	11.4 Electrostatic Discharge Caution.....	20
<b>7 Detailed Description</b> .....	11	11.5 Glossary.....	20
7.1 Overview.....	11	<b>12 Revision History</b> .....	21
7.2 Functional Block Diagram.....	11	<b>13 Mechanical, Packaging, and Orderable Information</b> .....	21
7.3 Feature Description.....	11		

## 4 Pin Configuration and Functions

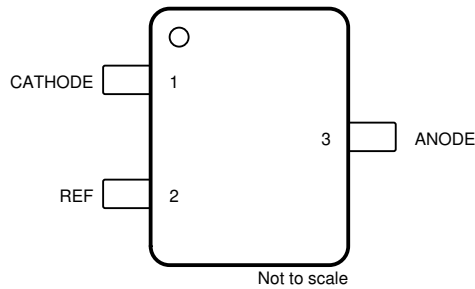

**Figure 4-1. ATL431 DBZ Package  
3-Pin SOT-23  
Top View**

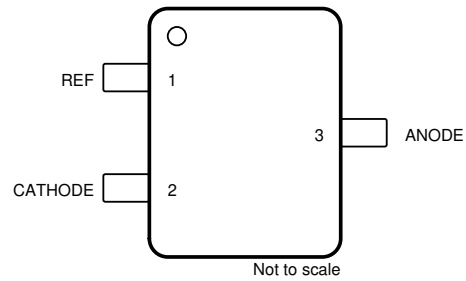

**Figure 4-2. ATL432 DBZ Package  
3-Pin SOT-23  
Top View**

**Table 4-1. Pin Functions**

NAME	PIN		I/O	DESCRIPTION
	NO.			
	ATL431x	ATL432x		
CATHODE	1	2	I/O	Shunt Current/Voltage input
REF	2	1	I	Threshold relative to common anode
ANODE	3	3	O	Common pin, normally connected to ground

## 5 Specifications

### 5.1 Absolute Maximum Ratings

over operating free-air temperature range (unless otherwise noted)<sup>(1)</sup>

		MIN	MAX	UNIT
$V_{KA}$	Cathode voltage <sup>(2)</sup>		40	V
$I_{KA}$	Continuous cathode current	-100	150	mA
$I_{I(ref)}$	Reference input current	-0.05	10	mA
$T_J$	Operating virtual junction temperature	-40	150	°C
$T_{stg}$	Storage temperature	-65	150	°C

- (1) Stresses beyond those listed under *Absolute Maximum Ratings* may cause permanent damage to the device. These are stress ratings only, and functional operation of the device at these or any other conditions beyond those indicated under *Recommended Operating Conditions* is not implied. Exposure to absolute-maximum-rated conditions for extended periods may affect device reliability.
- (2) All voltage values are with respect to ANODE, unless otherwise noted.

### 5.2 ESD Ratings

		VALUE	UNIT
$V_{(ESD)}$	Electrostatic discharge	Human-body model (HBM), per ANSI/ESDA/JEDEC JS-001 <sup>(1)</sup>	±2000
		Charged-device model (CDM), per JEDEC specification JESD22-C101 <sup>(2)</sup>	±1000

- (1) JEDEC document JEP155 states that 500V HBM allows safe manufacturing with a standard ESD control process.
- (2) JEDEC document JEP157 states that 250V CDM allows safe manufacturing with a standard ESD control process.

### 5.3 Recommended Operating Conditions

		MIN	MAX	UNIT
$V_{KA}$	Cathode voltage	$V_{ref}$	36	V
$I_{KA}$	Cathode current	.035	100	mA
$T_A$	Operating free-air temperature	I Grade	-40	85
		Q Grade	-40	125

## 5.4 Thermal Information

THERMAL METRIC <sup>(1)</sup>		ATL43x	UNIT
		DBZ (SOT-23)	
		3 PINS	
R <sub>θJA</sub>	Junction-to-ambient thermal resistance	331.8	°C/W
R <sub>θJC(top)</sub>	Junction-to-case (top) thermal resistance	106.5	°C/W
R <sub>θJB</sub>	Junction-to-board thermal resistance	64.6	°C/W
ψ <sub>JT</sub>	Junction-to-top characterization parameter	4.9	°C/W
ψ <sub>JB</sub>	Junction-to-board characterization parameter	62.9	°C/W

(1) For more information about traditional and new thermal metrics, see the [Semiconductor and IC Package Thermal Metrics](#) application report.

## 5.5 Electrical Characteristics, ATL431Ax, ATL432Ax

over recommended operating conditions, T<sub>A</sub> = 25°C (unless otherwise noted)

PARAMETER	TEST CIRCUIT	TEST CONDITIONS	MIN	TYP	MAX	UNIT
V <sub>ref</sub>	Reference voltage	Figure 6-1 V <sub>KA</sub> = V <sub>ref</sub> , I <sub>KA</sub> = 1mA	2475	2500	2525	mV
V <sub>I(dev)</sub>	Deviation of reference input voltage over full temperature range, see section	Figure 6-1 V <sub>KA</sub> = V <sub>ref</sub> , I <sub>KA</sub> = 1mA,		5	15	mV
				6	34	
ΔV <sub>ref</sub> / ΔV <sub>KA</sub>	Ratio of change in reference voltage to the change in cathode voltage	Figure 6-2 I <sub>KA</sub> = 1mA		-0.4	-2.7	mV/V
				-0.1	-2	
I <sub>ref</sub>	Reference input current	Figure 6-2 I <sub>KA</sub> = 1mA, R1 = 10kΩ, R2 = ∞		30	150	nA
I <sub>I(dev)</sub>	Deviation of reference input current over full temperature range, see section	Figure 6-2 I <sub>KA</sub> = 1mA, R1 = 10kΩ, R2 = ∞		20	50	nA
I <sub>min</sub>	Minimum cathode current for regulation	Figure 6-1 Figure 5-5 V <sub>KA</sub> = V <sub>ref</sub>		20	35	μA
I <sub>off</sub>	Off-state cathode current	Figure 6-3 V <sub>KA</sub> = 36V, V <sub>ref</sub> = 0		0.05	0.2	μA
z <sub>KA</sub>	Dynamic impedance, see section	Figure 6-1 V <sub>KA</sub> = V <sub>ref</sub> , f ≤ 1 kHz, I <sub>KA</sub> = 1 mA to 100 mA		0.05	0.3	Ω

## 5.6 Electrical Characteristics, ATL431Bx, ATL432Bx

over recommended operating conditions, T<sub>A</sub> = 25°C (unless otherwise noted)

PARAMETER	TEST CIRCUIT	TEST CONDITIONS	MIN	TYP	MAX	UNIT
V <sub>ref</sub>	Reference voltage	Figure 6-1 V <sub>KA</sub> = V <sub>ref</sub> , I <sub>KA</sub> = 1mA	2487	2500	2512	mV
V <sub>I(dev)</sub>	Deviation of reference input voltage over full temperature range, see section	Figure 6-1 V <sub>KA</sub> = V <sub>ref</sub> , I <sub>KA</sub> = 1mA		5	15	mV
				6	34	
ΔV <sub>ref</sub> / ΔV <sub>KA</sub>	Ratio of change in reference voltage to the change in cathode voltage	Figure 6-2 I <sub>KA</sub> = 1mA		-0.4	-2.7	mV/V
				-0.1	-2	
I <sub>ref</sub>	Reference input current	Figure 6-2 I <sub>KA</sub> = 1mA, R1 = 10kΩ, R2 = ∞		30	150	nA
I <sub>I(dev)</sub>	Deviation of reference input current over full temperature range, see section	Figure 6-2 I <sub>KA</sub> = 1mA, R1 = 10kΩ, R2 = ∞		20	50	nA
I <sub>min</sub>	Minimum cathode current for regulation	Figure 6-1 Figure 5-5 V <sub>KA</sub> = V <sub>ref</sub>		20	35	μA
I <sub>off</sub>	Off-state cathode current	Figure 6-3 V <sub>KA</sub> = 36V, V <sub>ref</sub> = 0		0.05	0.2	μA
z <sub>KA</sub>	Dynamic impedance, see section	Figure 6-1 V <sub>KA</sub> = V <sub>ref</sub> , f ≤ 1 kHz, I <sub>KA</sub> = 1 mA to 100 mA		0.05	0.3	Ω

### 5.7 Typical Characteristics

Data at high and low temperatures are applicable only within the recommended operating free-air temperature ranges of the various devices.

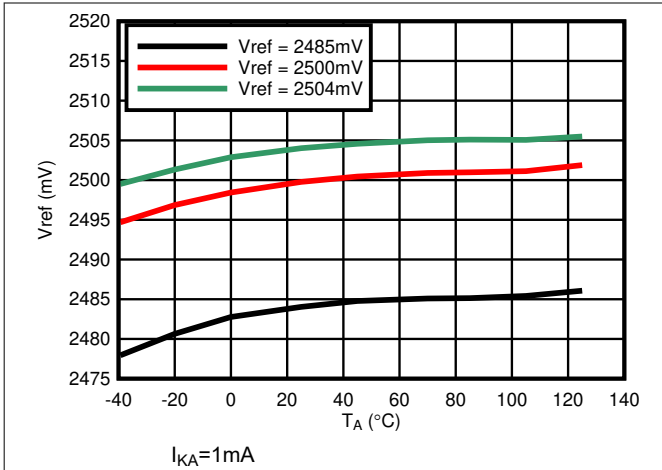

Figure 5-1. Reference Voltage vs Free-Air Temperature

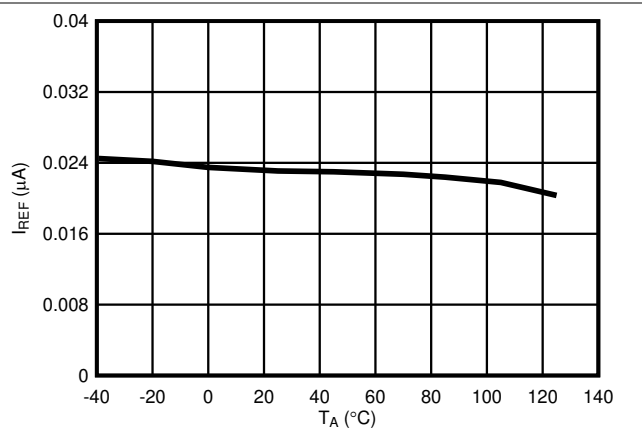

Figure 5-2. Reference Current vs Free-Air Temperature

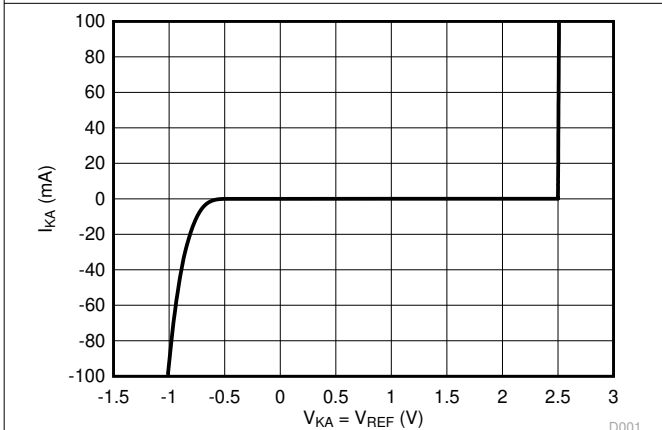

Figure 5-3. Cathode Current vs Cathode Voltage

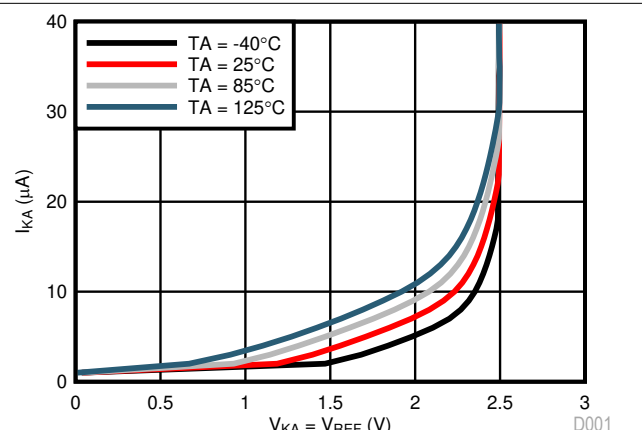

Figure 5-4. Cathode Current vs Cathode Voltage

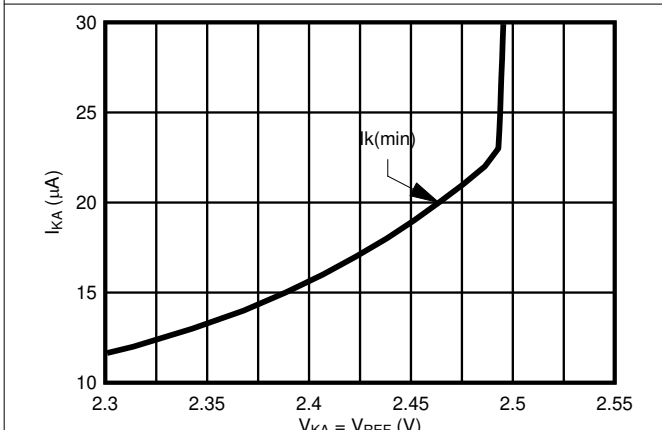

Figure 5-5. Cathode Current vs Cathode Voltage

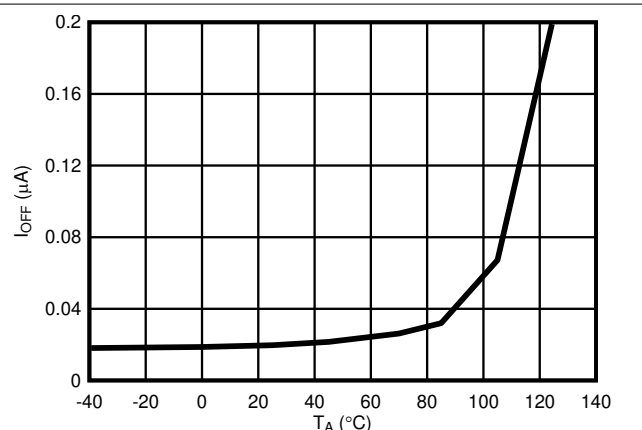

Figure 5-6. Off-State Cathode Current vs Free-Air Temperature

### 5.7 Typical Characteristics (continued)

Data at high and low temperatures are applicable only within the recommended operating free-air temperature ranges of the various devices.

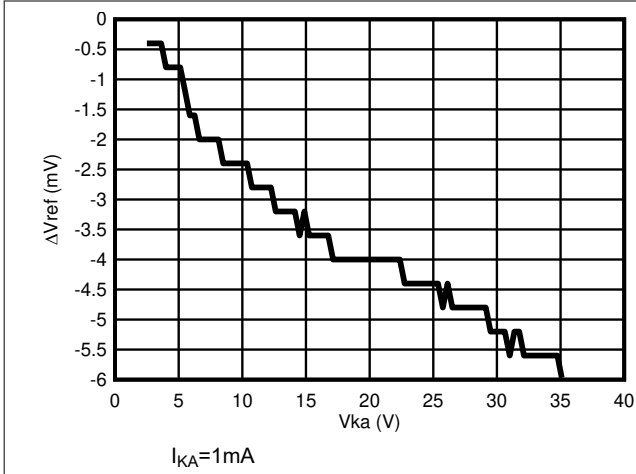

Figure 5-7. Delta Reference Voltage vs Cathode Voltage

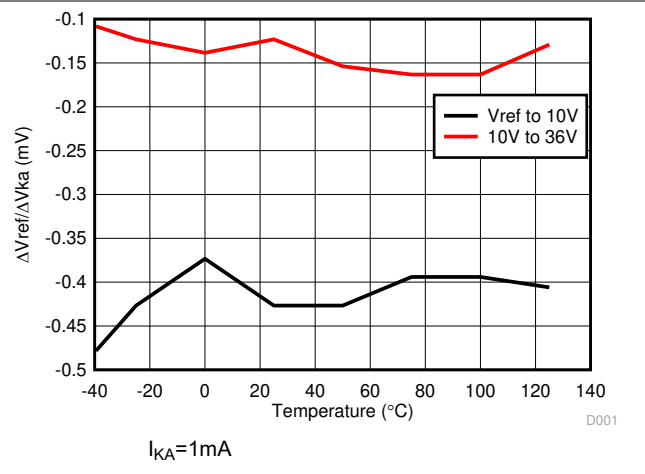

Figure 5-8. Delta Reference Voltage vs Cathode Voltage

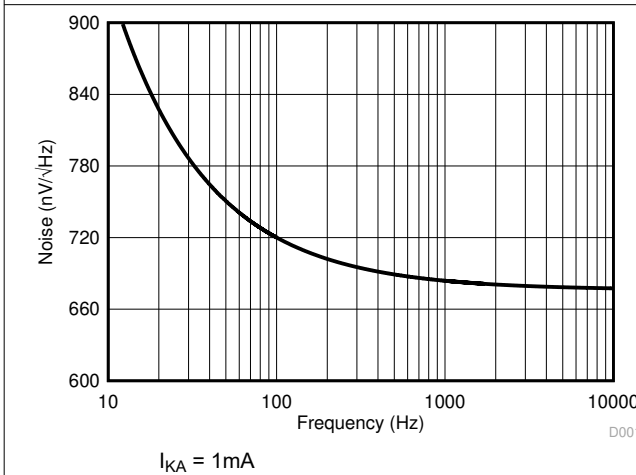

Figure 5-9. Noise Voltage

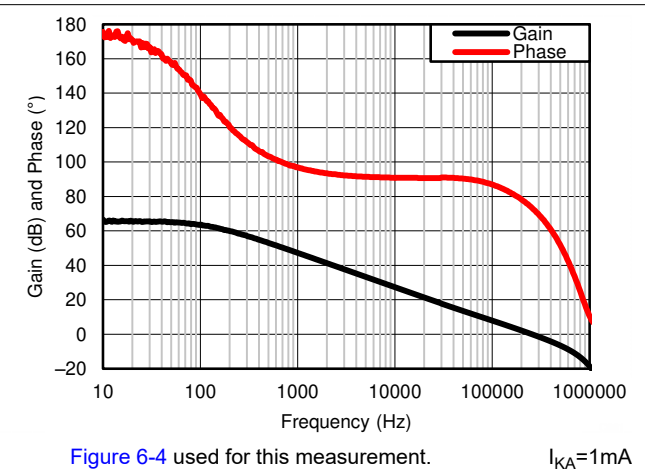

Figure 5-10. Small-Signal Voltage Amplification vs Frequency

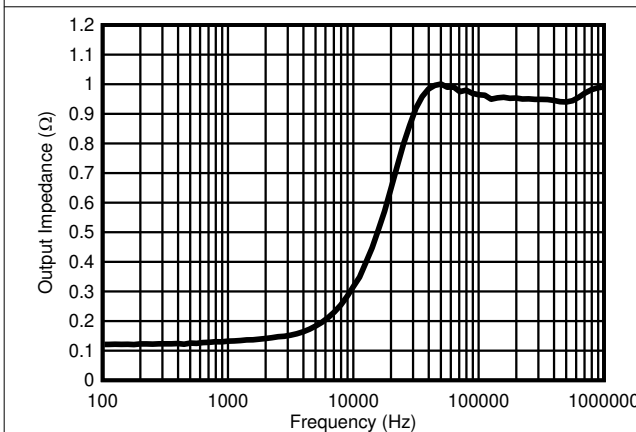

Figure 5-11. Output Impedance vs Frequency

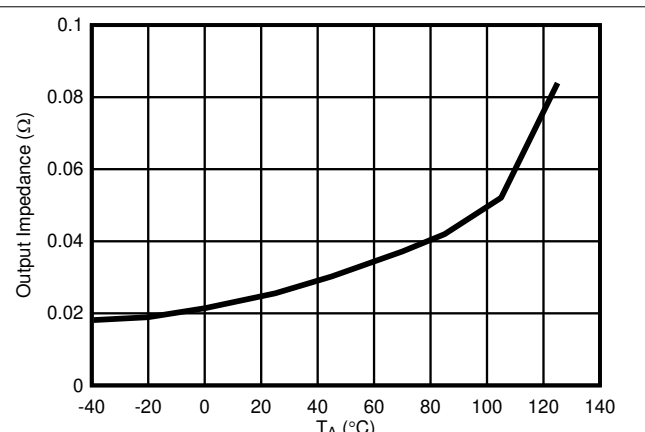
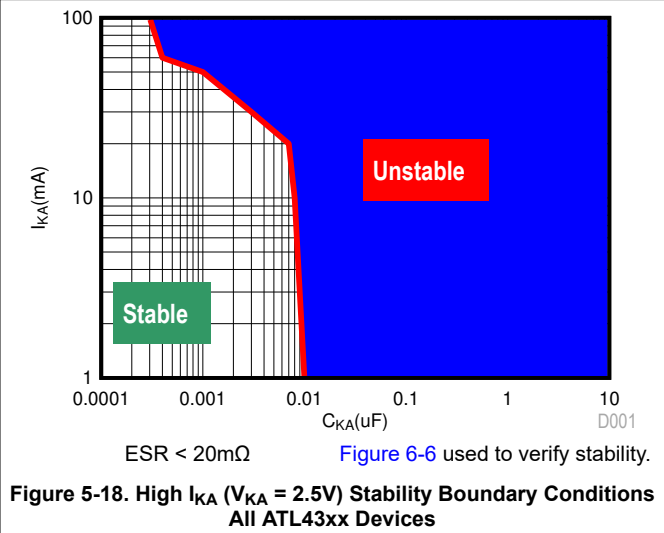
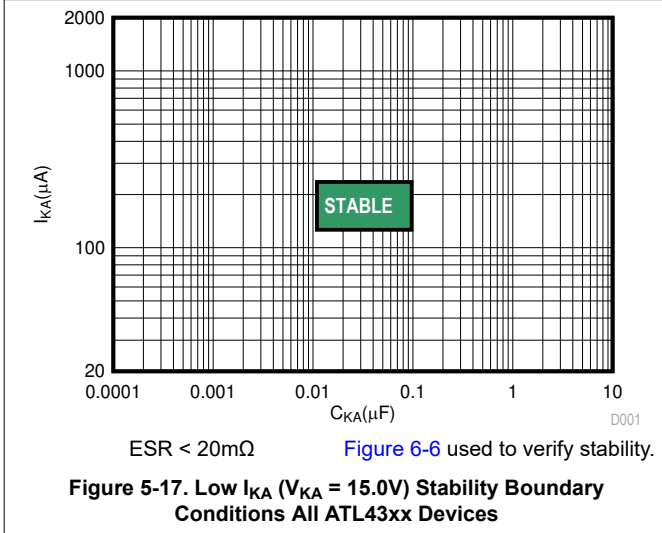
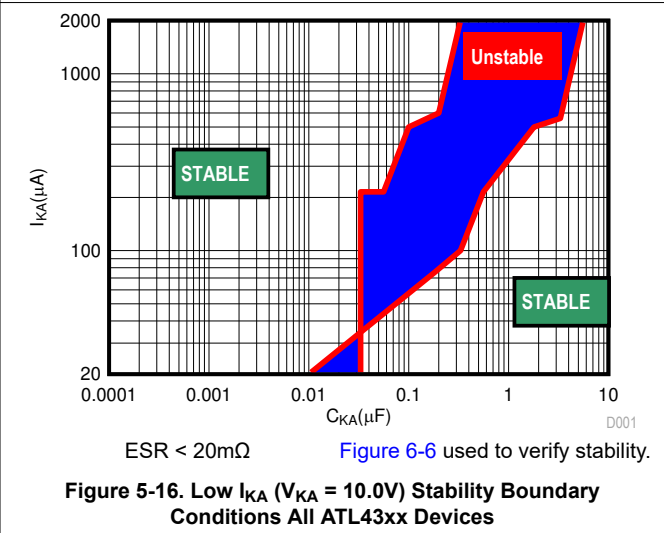
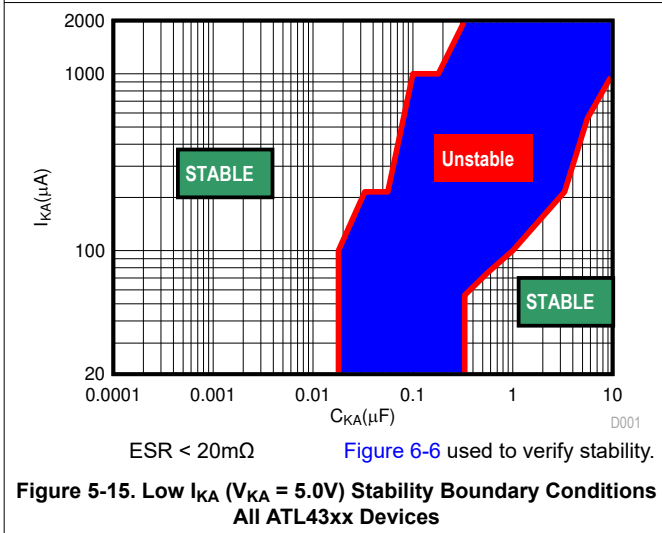
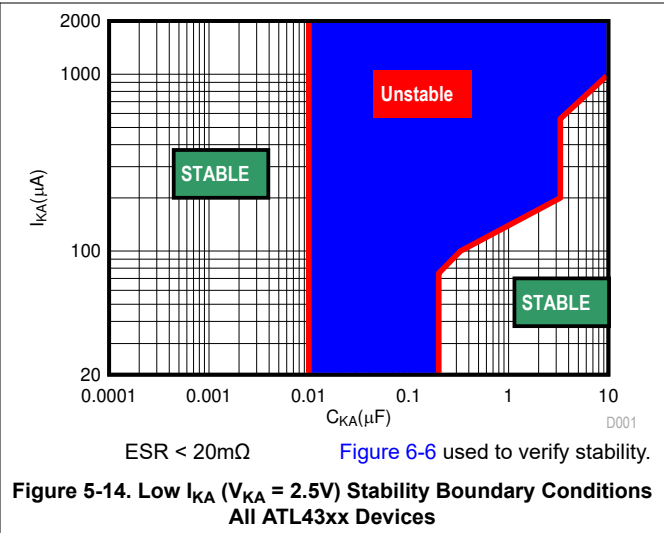
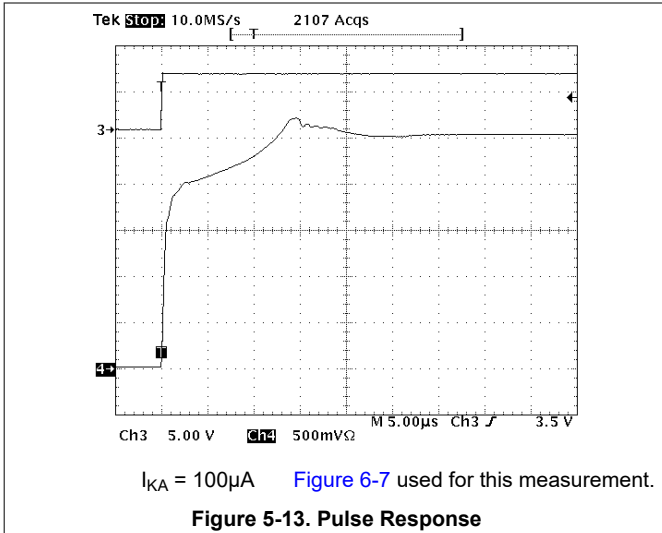

Figure 5-12. DC Output Impedance vs Temperature

### 5.7 Typical Characteristics (continued)

Data at high and low temperatures are applicable only within the recommended operating free-air temperature ranges of the various devices.



### 5.7 Typical Characteristics (continued)

Data at high and low temperatures are applicable only within the recommended operating free-air temperature ranges of the various devices.

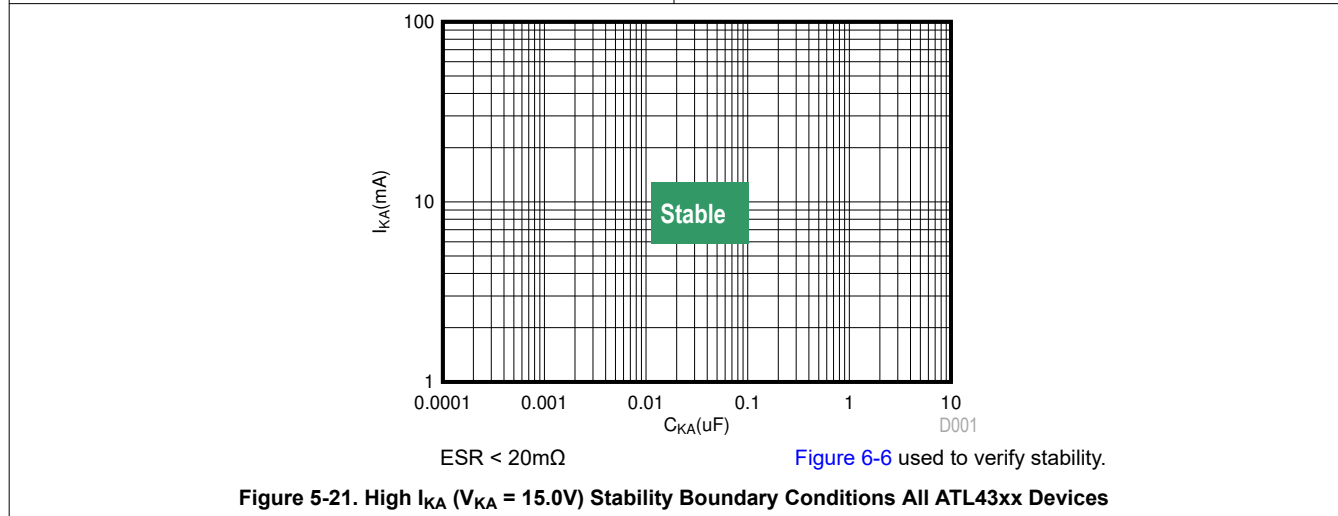
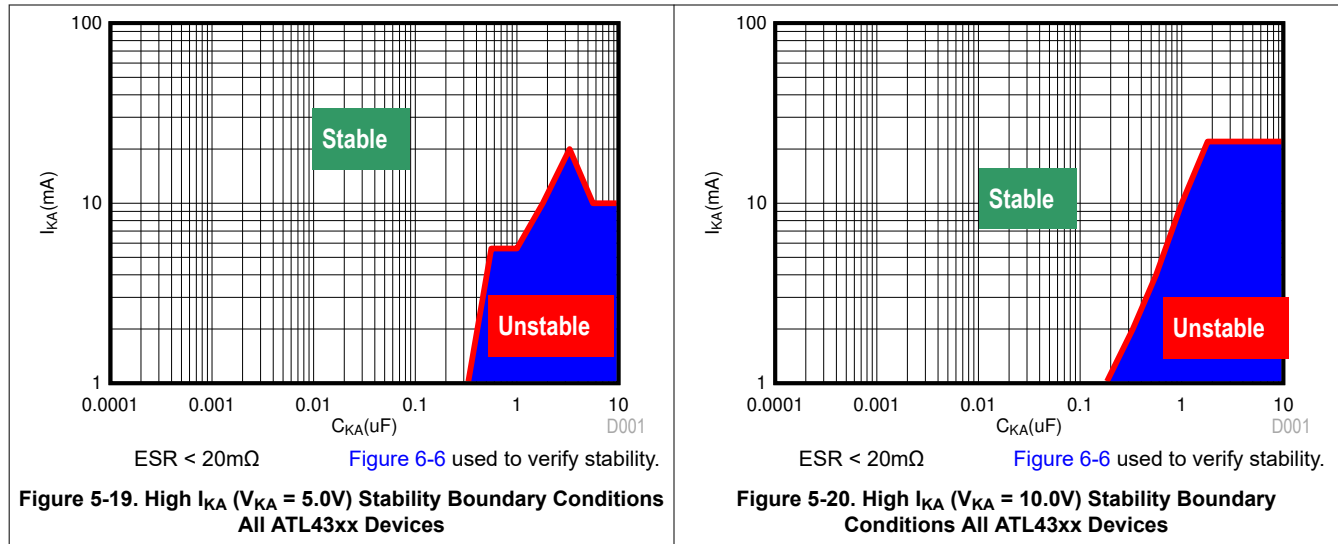

## 6 Parameter Measurement Information

The deviation parameters  $V_{ref(dev)}$  and  $I_{ref(dev)}$  are defined as the differences between the maximum and minimum values obtained over the rated temperature range. The average full-range temperature coefficient of the reference input voltage  $\alpha_{Vref}$  is defined as:

$$|\alpha_{Vref}| \left( \frac{ppm}{^{\circ}C} \right) = \frac{\left( \frac{V_{I(dev)}}{V_{ref \text{ at } 25^{\circ}C}} \right) \times 10^6}{\Delta T_A}$$

where:

$\Delta T_A$  is the rated operating temperature range of the device.

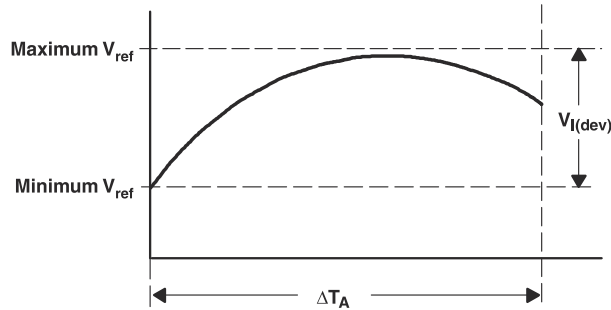

$\alpha_{Vref}$  is positive or negative, depending on whether minimum  $V_{ref}$  or maximum  $V_{ref}$ , respectively, occurs at the lower temperature.

The dynamic impedance is defined as:  $|z_{KA}| = \frac{\Delta V_{KA}}{\Delta I_{KA}}$

When the device is operating with two external resistors (see Figure 6-2), the total dynamic impedance of the circuit is given by:  $|z'| = \frac{\Delta V}{\Delta I}$  which is approximately equal to  $|z_{KA}| \left( 1 + \frac{R1}{R2} \right)$

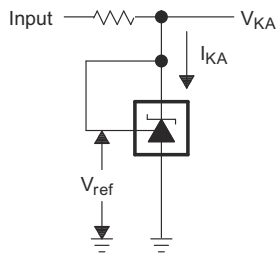

Figure 6-1. Test Circuit for  $V_{KA} = V_{ref}$

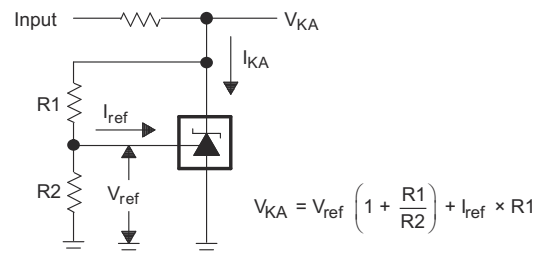

Figure 6-2. Test Circuit for  $V_{KA} > V_{ref}$

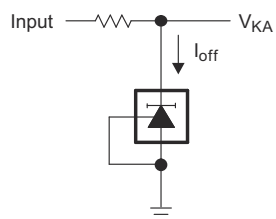

Figure 6-3. Test Circuit for  $I_{off}$

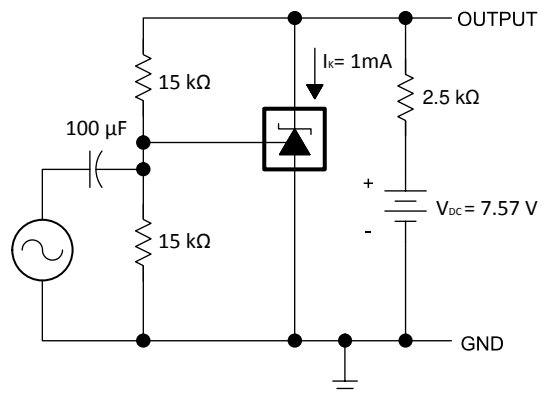
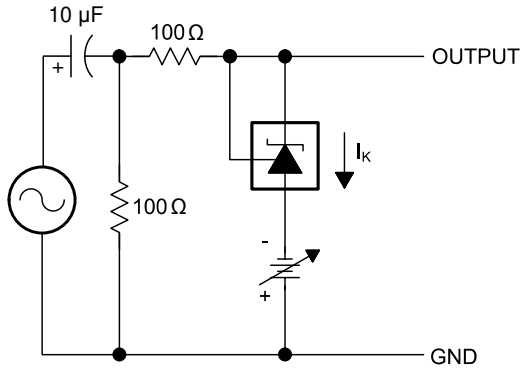
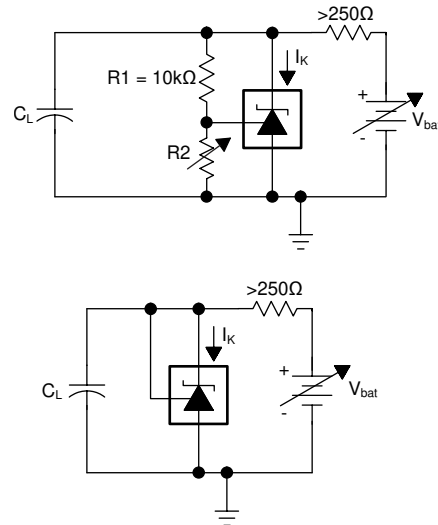

Figure 6-4. Test Circuit for Phase and Gain Measurement



**Figure 6-5. Test Circuit for Reference Impedance ( $Z_{KA}$ )**



**Figure 6-6. Test Circuit for Stability Boundary Conditions**

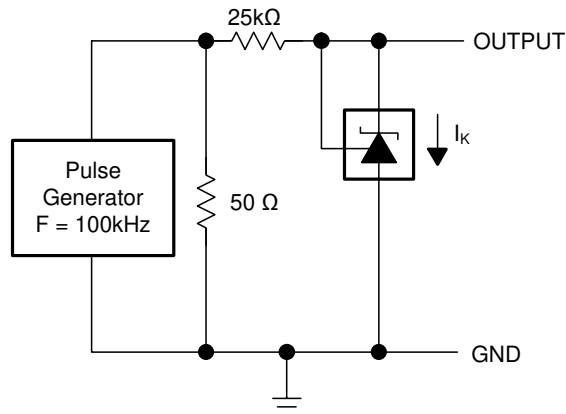

**Figure 6-7. Test Circuit for Pulse Response**

## 7 Detailed Description

### 7.1 Overview

The ATL43x is a low power counterpart to TL431 and TLV431, having lower minimum cathode current ( $I_{k(\min)} = 35\mu\text{A}$ ). Like the TL431, the ATL43x is used in conjunction with its key components to behave as a single voltage reference, error amplifier, voltage clamp, or comparator with integrated reference.

The ATL43x can be operated and adjusted to cathode voltages from 2.5V to 36V, this part is an excellent choice for a wide range of end equipments in industrial, auto, telecom and computing. For this device to behave as a shunt regulator or error amplifier,  $> 35\mu\text{A}$  ( $I_{\min(\max)}$ ) must be supplied in to the cathode pin. Under this condition, feedback can be applied from the Cathode and Ref pins to create a replica of the internal reference voltage.

Various reference voltage options can be purchased with initial tolerances (at 25°C) of 0.5% and 1.0%. These reference options are denoted by B (0.5%) and A (1.0%) after the ATL43x.

The ATL43xxl devices are characterized for operation from  $-40^{\circ}\text{C}$  to  $+85^{\circ}\text{C}$ , and the ATL43xxQ devices are characterized for operation from  $-40^{\circ}\text{C}$  to  $+125^{\circ}\text{C}$ .

### 7.2 Functional Block Diagram

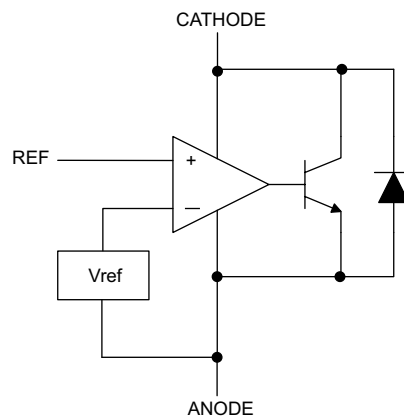

Copyright © 2017, Texas Instruments Incorporated

### 7.3 Feature Description

ATL43x consists of an internal reference and amplifier that outputs a sink current based on the difference between the reference pin and the virtual internal pin. The sink current is produced by an internal Darlington pair.

When operated with enough voltage headroom ( $\geq 2.5\text{V}$ ) and cathode current ( $I_{KA}$ ), ATL43x forces the reference pin to 2.5V. However, the reference pin can not be left floating, as it needs  $I_{\text{ref}} \geq 0.1\mu\text{A}$  (please see the [Functional Block Diagram](#)). This is because the reference pin is driven into an NPN, which needs base current in order to operate properly.

When feedback is applied from the Cathode and Reference pins, ATL43x behaves as a Zener diode, regulating to a constant voltage dependent on current being supplied into the cathode. This is due to the internal amplifier and reference entering the proper operating regions. The same amount of current required in the above feedback situation must be applied to this device in open-loop, servo, or error amplifying implementations for the current to be in the proper linear region to give the ATL43x enough gain.

Unlike many linear regulators, ATL43x is internally compensated to be stable without an output capacitor between the cathode and anode; however, if it is desired to use an output capacitor, [Figure 5-14](#) through [Figure 5-21](#) can be used as a guide to assist in choosing the correct capacitor to maintain stability.

## 7.4 Device Functional Modes

### 7.4.1 Open Loop (Comparator)

When the cathode/output voltage or current of ATL43x is not being fed back to the reference/input pin in any form, this device is operating in open loop. With such high gain in this configuration, the ATL43x is typically used as a comparator. Due to the integrated reference, the ATL43x allows users to monitor a certain level of a single signal.

### 7.4.2 Closed Loop

When the cathode/output voltage or current of ATL43x is being fed back to the reference/input pin in any form, this device is operating in closed loop. The majority of applications involving the ATL43x use it in this manner to regulate a fixed voltage or current. The feedback enables this device to behave as an error amplifier, computing a portion of the output voltage and adjusting it to maintain the desired regulation. This is done by relating the output voltage back to the reference pin in a manner to make it equal to the internal reference voltage, which can be accomplished via resistive or direct feedback.

## 8 Application and Implementation

### Note

Information in the following applications sections is not part of the TI component specification, and TI does not warrant its accuracy or completeness. TI's customers are responsible for determining suitability of components for their purposes, as well as validating and testing their design implementation to confirm system functionality.

### 8.1 Application Information

Figure 8-1 shows the ATL43x used in a 24-V isolated flyback supply. The output of the regulator, plus the forward voltage drop of the optocoupler LED ( $2.5 + 0.7 = 3.2\text{V}$ ), determine the minimum voltage that can be regulated in an isolated supply configuration. Regulated voltage as low as 5.0Vdc is possible in the topology shown in Figure 8-1.

The 431 family of devices are prevalent in these applications, being designers go-to choice for secondary side regulation. Due to this prevalence, this section will further go on to explain operation and design in both states of the ATL43x that this application sees: open-loop (Comparator +  $V_{ref}$ ) and closed-loop (Shunt Regulator).

The key benefit in isolated supplies for the ATL43x is the no load power savings gained by the  $> 20\text{x}$  decrease in  $I_{Kmin}$  from TL431. More information about this and other benefits can be found in [Designing with the "Advanced" TL431, ATL431](#) (SLVA685). Further information about system stability and using a ATL43x device for compensation can be found in [Compensation Design With TL431 for UCC28600](#) (SLUA671).

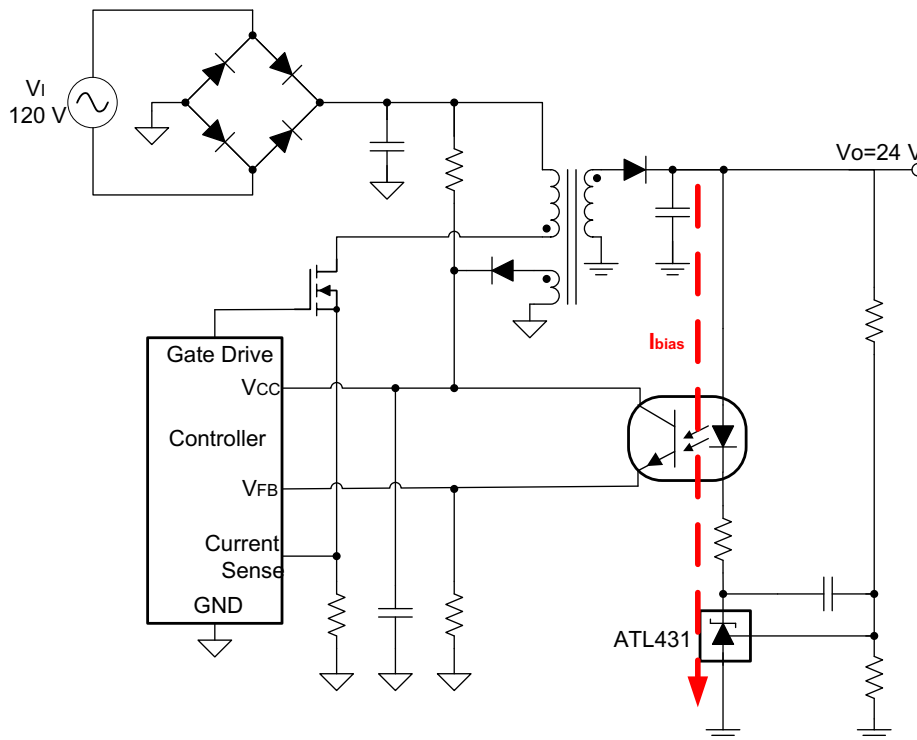

Copyright © 2017, Texas Instruments Incorporated

**Figure 8-1. Flyback With Isolation Using ATL43x as Voltage Reference and Error Amplifier**

It is important to consider the cathode voltage ramp rate when using ATL431 or ATL432 in overvoltage protection or other voltage monitoring applications, in optocoupler configurations, or any configuration where a power supply may ramp the cathode voltage quickly while ATL431 or ATL432 is meant to be in operation. For fast cathode current ramp rates, inaccurate responses may occur which can trip voltage monitoring circuits when

an overvoltage or undervoltage condition has not actually been met. When designing with ATL431 or ATL432, it is recommended that the ramp rate of the cathode voltage remain below 0.0125V/μs to mitigate potential inaccuracies.

For voltage monitoring or other applications where a ramp rate faster than 0.0125 V/μs is required, please consider other high-performance, pin-to-pin devices from TI: ATL431LI, TLA431, or TL431.

## 8.2 Typical Applications

### 8.2.1 Comparator With Integrated Reference (Open-Loop)

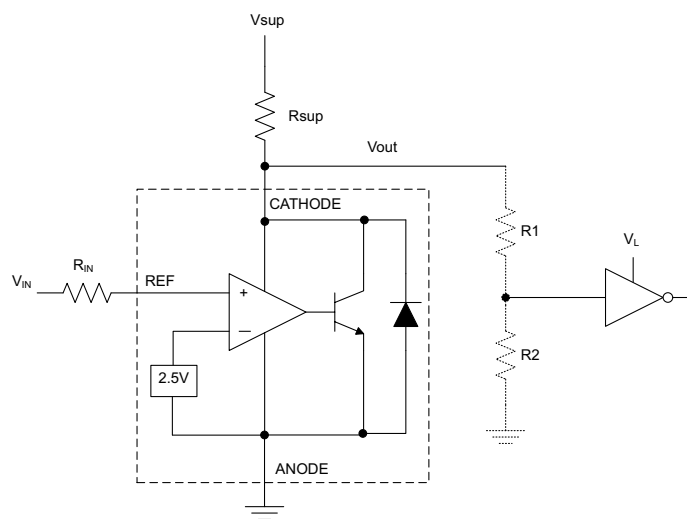

Copyright © 2017, Texas Instruments Incorporated

**Figure 8-2. Comparator Application Schematic**

#### 8.2.1.1 Design Requirements

For this design example, use the parameters listed in [Table 8-1](#) as the input parameters.

**Table 8-1. Design Parameters**

DESIGN PARAMETER	EXAMPLE VALUE
Input voltage range	0V to 3.3V
Input resistance	100kΩ
Supply voltage	5V
Cathode current ( $I_K$ )	50μA
High output voltage level ( $V_{in} < 2.5V$ )	$V_{sup}$
Low output voltage ( $V_{in} > 2.5V$ )	~2V

#### 8.2.1.2 Detailed Design Procedure

When using the ATL43x as a comparator with reference, determine the following:

- Input voltage range
- Reference voltage accuracy
- Output logic input high and low level thresholds
- Current source resistance

##### 8.2.1.2.1 Basic Operation

In the configuration shown in [Figure 8-2](#), the ATL43x behaves as a comparator, comparing the  $V_{ref}$  pin voltage to the internal virtual reference voltage. When provided a proper cathode current ( $I_K$ ), ATL43x have enough

open-loop gain to provide a quick response. With the maximum operating current ( $I_{\min}$ ) of ATL43x being 35 $\mu$ A, operation below that can result in low gain; leading to a slow response.

#### 8.2.1.2.2 Overdrive

Slow or inaccurate responses can also occur when the reference pin is not provided enough overdrive voltage. This is the amount of voltage that is higher than the internal virtual reference. The internal virtual reference voltage will be within the range of 2.5V  $\pm$  (0.5% or 1.0%) depending on which version is being used.

The more overdrive voltage provided, the faster the ATL43x responds.

For applications where ATL43x is being used as a comparator, it is best to set the trip point to greater than the positive expected error (that is, +1.0% for the A version). For fast response, setting the trip point to > 10% of the internal  $V_{\text{ref}}$  should suffice. [Figure 8-3](#) shows the transition from  $V_{\text{OH}}$  to  $V_{\text{OL}}$  based on the input voltage and can be used as a guide for selecting the overdrive voltage.

For minimal voltage drop or difference from  $V_{\text{in}}$  to the ref pin, TI recommends using an input resistor < 1M $\Omega$  to provide  $I_{\text{ref}}$ .

#### 8.2.1.2.3 Output Voltage and Logic Input Level

In order for ATL43x to properly be used as a comparator, the logic output must be readable by the receiving logic device. This is accomplished by knowing the input high and low level threshold voltage levels, typically denoted by  $V_{\text{IH}}$  and  $V_{\text{IL}}$ .

As seen in [Figure 8-3](#), the output low level voltage for ATL43x in open-loop/comparator mode is ~2V, which is sufficient for some  $\geq$  5-V supplied logic. However, would not work for 3.3-V and 1.8-V supplied logic. To accommodate this, a resistive divider can be tied to the output to attenuate the output voltage to a voltage legible to the receiving low voltage logic device.

The output high voltage for ATL43x is approximately  $V_{\text{sup}}$  due to ATL43x being open-collector. If  $V_{\text{sup}}$  is much higher than the receiving maximum input voltage tolerance of the logic, the output must be attenuated to accommodate the reliability of the outgoing logic.

When using a resistive divider on the output, ensure that the sum of the resistive divider ( $R_1$  and  $R_2$  in [Figure 8-2](#)) is much greater than  $R_{\text{sup}}$  so that the resistive divider does not interfere with the ability of the ATL43x to pull close to  $V_{\text{sup}}$  when turning off.

#### 8.2.1.2.3.1 Input Resistance

ATL43x requires an input resistance in this application in order to source the reference current ( $I_{\text{ref}}$ ) needed from this device to be in the proper operating regions while turning on. The actual voltage seen at the ref pin will be:

$$V_{\text{ref}} = V_{\text{in}} - I_{\text{ref}} \times R_{\text{in}} \quad (1)$$

Because  $I_{\text{ref}}$  can be as high as 0.15 $\mu$ A, TI recommends using a resistance small enough that will mitigate the error that  $I_{\text{ref}}$  creates from  $V_{\text{in}}$ . Also, the input resistance must be set high enough as to not surpass the absolute maximum of 10mA.

### 8.2.1.3 Application Curve

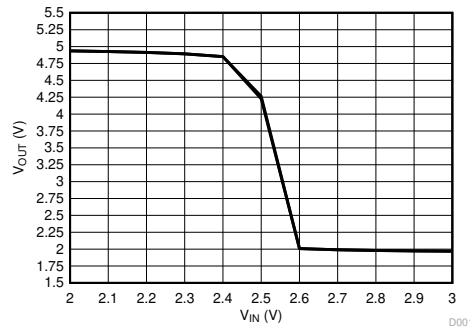

$R_{IN} = 100k\Omega$

$V_{SUP} = 5.0V$

$R_{SUP} = 10k\Omega$

**Figure 8-3. Open-Loop (Comparator Mode)  $V_{OUT}$  vs  $V_{IN}$**

### 8.2.2 Shunt Regulator/Reference

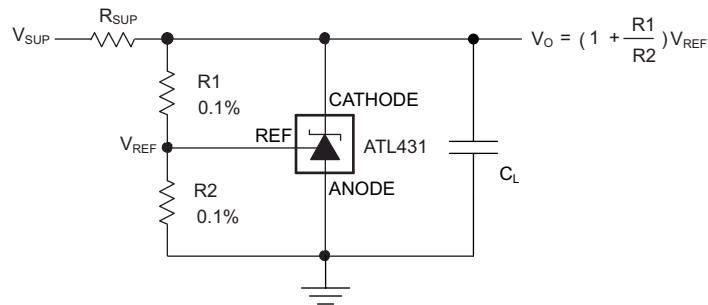

Copyright © 2017, Texas Instruments Incorporated

**Figure 8-4. Shunt Regulator Schematic**

#### 8.2.2.1 Design Requirements

For this design example, use the parameters listed in [Table 8-2](#) as the input parameters.

**Table 8-2. Design Parameters**

DESIGN PARAMETER	EXAMPLE VALUE
Reference initial accuracy	1.0%
Supply voltage	48V
Cathode current ( $I_K$ )	50 $\mu$ A
Output voltage level	2.5V to 36V
Load capacitance	1nF
Feedback resistor values ( $R_1$ and $R_2$ )	10k $\Omega$

#### 8.2.2.2 Detailed Design Procedure

When using the ATL43x as a Shunt Regulator, determine the following:

- Input voltage range
- Temperature range
- Total accuracy
- Cathode current
- Reference initial accuracy
- Output capacitance

### 8.2.2.2.1 Programming Output/Cathode Voltage

To program the cathode voltage to a regulated voltage a resistive bridge must be shunted between the cathode and anode pins with the mid point tied to the reference pin. This can be seen in [Figure 8-4](#), with R1 and R2 being the resistive bridge. The cathode/output voltage in the shunt regulator configuration can be approximated by the equation shown in [Figure 8-4](#). The cathode voltage can be more accurately determined by taking in to account the cathode current:

$$V_O = (1 + R1 / R2) \times V_{ref} - I_{ref} \times R1 \quad (2)$$

For this equation to be valid, the ATL43x must be fully biased so that it has enough open-loop gain to mitigate any gain error. This can be done by meeting the  $I_{min}$  spec denoted in [Electrical Characteristics, ATL431Ax, ATL432Ax](#) table.

### 8.2.2.2.2 Total Accuracy

When programming the output above unity gain ( $V_{KA} = V_{ref}$ ), ATL43x is susceptible to other errors that may effect the overall accuracy beyond  $V_{ref}$ . These errors include:

- R1 and R2 accuracies
- $V_{I(dev)}$  – Change in reference voltage over temperature
- $\Delta V_{ref} / \Delta V_{KA}$  – Change in reference voltage to the change in cathode voltage
- $|z_{KA}|$  – Dynamic impedance, causing a change in cathode voltage with cathode current

Worst case cathode voltage can be determined taking all of the variables in to account. [Setting the Shunt Voltage on an Adjustable Shunt](#) (SLVA445), assists designers in setting the shunt voltage to achieve optimum accuracy for this device.

### 8.2.2.2.3 Stability

Though the ATL43x is stable with no capacitive load, the device that receives the output voltage of the shunt regulator could present a capacitive load that is within the ATL43x region of stability, shown in [Figure 5-14](#) through [Figure 5-21](#). Also, designers can use capacitive loads to improve the transient response or for power supply decoupling.

[Figure 5-14](#) through [Figure 5-21](#) should be used as a guide for capacitor selection and compensation. It is characterized using ceramic capacitors with very-low ESR. When it is desirable to use a capacitor within the unstable region, higher ESR capacitors can be used to stabilize ATL43x or an external series resistance can be added. For more information and guidance on ESR values, see [Designing with the "Advanced" TL431, ATL431](#) (SLVA685).

Unlike the TL431, the stability boundary is characterized and determined with resistors 250 $\Omega$  and greater. Which is designed for low cathode current applications.

### 8.2.2.3 Application Curves

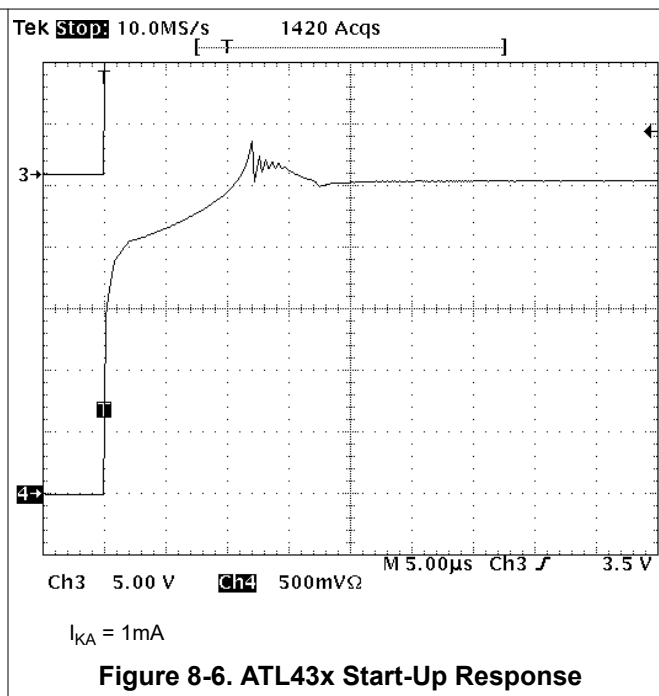
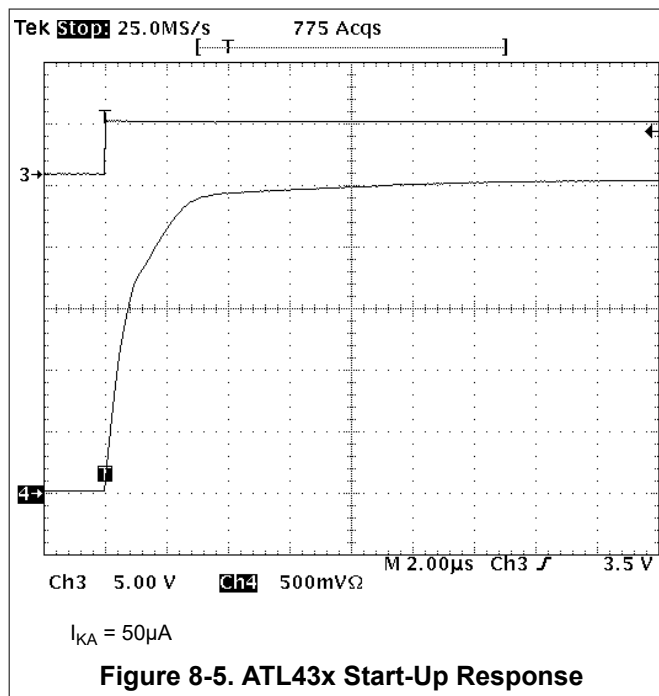

## 9 Power Supply Recommendations

When using the ATL43x in a flyback supply (see [Figure 8-1](#)), it is often common for designers to place the bias resistor between the Anode of the Opto-Coupler and the output voltage ( $V_O = 24V$ ). However, this makes the ATL43x more susceptible to EOS/ESD damage. Therefore, TI recommends placing the bias resistor between the Cathodes of the Opto-Coupler and the ATL43x, as shown in [Figure 8-1](#). For further explanation, see [Designing with the "Advanced" TL431, ATL431](#) (SLVA685).

When using the ATL43x as a Linear Regulator to supply a load, designers will typically use a bypass capacitor on the output/cathode pin. Be sure that the capacitance is within the stability criteria shown in [Figure 5-14](#) through [Figure 5-21](#).

To not exceed the maximum cathode current, be sure that the supply voltage is current limited. Also, be sure to limit the current being driven into the Ref pin, as not to exceed the absolute maximum rating.

For applications shunting high currents, pay attention to the cathode and anode trace lengths, adjusting the width of the traces to have the proper current density.

## 10 Layout

### 10.1 Layout Guidelines

Place decoupling capacitors as close to the device as possible. Use appropriate widths for traces when shunting high currents to avoid excessive voltage drops.

### 10.2 Layout Example

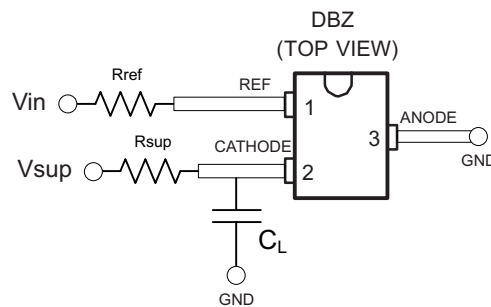

**Figure 10-1. DBZ Layout Example**

## 11 Device and Documentation Support

### 11.1 Receiving Notification of Documentation Updates

To receive notification of documentation updates, navigate to the device product folder on [ti.com](http://ti.com). Click on *Notifications* to register and receive a weekly digest of any product information that has changed. For change details, review the revision history included in any revised document.

### 11.2 Support Resources

[TI E2E™ support forums](#) are an engineer's go-to source for fast, verified answers and design help — straight from the experts. Search existing answers or ask your own question to get the quick design help you need.

Linked content is provided "AS IS" by the respective contributors. They do not constitute TI specifications and do not necessarily reflect TI's views; see TI's [Terms of Use](#).

### 11.3 Trademarks

TI E2E™ is a trademark of Texas Instruments.

All trademarks are the property of their respective owners.

### 11.4 Electrostatic Discharge Caution



This integrated circuit can be damaged by ESD. Texas Instruments recommends that all integrated circuits be handled with appropriate precautions. Failure to observe proper handling and installation procedures can cause damage.

ESD damage can range from subtle performance degradation to complete device failure. Precision integrated circuits may be more susceptible to damage because very small parametric changes could cause the device not to meet its published specifications.

### 11.5 Glossary

[TI Glossary](#) This glossary lists and explains terms, acronyms, and definitions.

## 12 Revision History

NOTE: Page numbers for previous revisions may differ from page numbers in the current version.

### Changes from Revision D (October 2016) to Revision E (December 2024) Page

- Updated the numbering format for tables, figures, and cross-references throughout the document..... 1
- Updated Application Information ..... 13

### Changes from Revision C (September 2015) to Revision D (October 2016) Page

- Changed *Small-Signal Voltage Amplification vs Frequency* with an updated graph to provide additional data. 5
- Changed *Test Circuit for Phase and Gain Measurement* with an updated schematic..... 9
- Updated Comparator Mode specifications in *Design Parameters* ..... 14
- Added *Receiving Notification of Documentation Updates* section.....20

### Changes from Revision B (May 2015) to Revision C (September 2015) Page

- Changed ATL432xx status from PREVIEW to PRODUCTION.....1

### Changes from Revision A (April 2015) to Revision B (May 2015) Page

- Changed ATL431AQ, ATL431BI and ATL431BQ status from PREVIEW to PRODUCTION.....1
- Changed flyback schematic to represent a more robust design ..... 13
- Added flyback supply reliability recommendation..... 19

### Changes from Revision \* (March 2013) to Revision A (April 2015) Page

- Initial release of full version..... 1

## 13 Mechanical, Packaging, and Orderable Information

The following pages include mechanical, packaging, and orderable information. This information is the most current data available for the designated devices. This data is subject to change without notice and revision of this document. For browser-based versions of this data sheet, refer to the left-hand navigation.

**PACKAGING INFORMATION**

Orderable part number	Status (1)	Material type (2)	Package   Pins	Package qty   Carrier	RoHS (3)	Lead finish/ Ball material (4)	MSL rating/ Peak reflow (5)	Op temp (°C)	Part marking (6)
<a href="#">ATL431AIDBZR</a>	Active	Production	SOT-23 (DBZ)   3	3000   LARGE T&R	Yes	NIPDAU   NIPDAUAG	Level-1-260C-UNLIM	-40 to 85	(ZCKS, ZCR3)
ATL431AIDBZR.A	Active	Production	SOT-23 (DBZ)   3	3000   LARGE T&R	Yes	NIPDAU	Level-1-260C-UNLIM	-40 to 85	(ZCKS, ZCR3)
<a href="#">ATL431AQDBZR</a>	Active	Production	SOT-23 (DBZ)   3	3000   LARGE T&R	Yes	NIPDAU   NIPDAUAG	Level-1-260C-UNLIM	-40 to 125	(ZCLS, ZCS3)
ATL431AQDBZR.A	Active	Production	SOT-23 (DBZ)   3	3000   LARGE T&R	Yes	NIPDAU	Level-1-260C-UNLIM	-40 to 125	(ZCLS, ZCS3)
<a href="#">ATL431BIDBZR</a>	Active	Production	SOT-23 (DBZ)   3	3000   LARGE T&R	Yes	NIPDAU   NIPDAUAG	Level-1-260C-UNLIM	-40 to 85	(ZCMS, ZCT3)
ATL431BIDBZR.A	Active	Production	SOT-23 (DBZ)   3	3000   LARGE T&R	Yes	NIPDAU	Level-1-260C-UNLIM	-40 to 85	(ZCMS, ZCT3)
<a href="#">ATL431BQDBZR</a>	Active	Production	SOT-23 (DBZ)   3	3000   LARGE T&R	Yes	NIPDAU   NIPDAUAG	Level-1-260C-UNLIM	-40 to 125	(ZCJS, ZCU3)
ATL431BQDBZR.A	Active	Production	SOT-23 (DBZ)   3	3000   LARGE T&R	Yes	NIPDAU	Level-1-260C-UNLIM	-40 to 125	(ZCJS, ZCU3)
<a href="#">ATL432AIDBZR</a>	Active	Production	SOT-23 (DBZ)   3	3000   LARGE T&R	Yes	NIPDAU   NIPDAUAG	Level-1-260C-UNLIM	-40 to 85	(ZCNS, ZCV3)
ATL432AIDBZR.A	Active	Production	SOT-23 (DBZ)   3	3000   LARGE T&R	Yes	NIPDAU	Level-1-260C-UNLIM	-40 to 85	(ZCNS, ZCV3)
<a href="#">ATL432AQDBZR</a>	Active	Production	SOT-23 (DBZ)   3	3000   LARGE T&R	Yes	NIPDAU   NIPDAUAG	Level-1-260C-UNLIM	-40 to 125	(ZCOS, ZCW3)
ATL432AQDBZR.A	Active	Production	SOT-23 (DBZ)   3	3000   LARGE T&R	Yes	NIPDAU	Level-1-260C-UNLIM	-40 to 125	(ZCOS, ZCW3)
<a href="#">ATL432BIDBZR</a>	Active	Production	SOT-23 (DBZ)   3	3000   LARGE T&R	Yes	NIPDAU   NIPDAUAG	Level-1-260C-UNLIM	-40 to 85	(ZCPS, ZCX3)
ATL432BIDBZR.A	Active	Production	SOT-23 (DBZ)   3	3000   LARGE T&R	Yes	NIPDAU	Level-1-260C-UNLIM	-40 to 85	(ZCPS, ZCX3)
<a href="#">ATL432BQDBZR</a>	Active	Production	SOT-23 (DBZ)   3	3000   LARGE T&R	Yes	NIPDAU   NIPDAUAG	Level-1-260C-UNLIM	-40 to 125	(ZCQS, ZCY3)
ATL432BQDBZR.A	Active	Production	SOT-23 (DBZ)   3	3000   LARGE T&R	Yes	NIPDAU	Level-1-260C-UNLIM	-40 to 125	(ZCQS, ZCY3)

(1) **Status:** For more details on status, see our [product life cycle](#).

(2) **Material type:** When designated, preproduction parts are prototypes/experimental devices, and are not yet approved or released for full production. Testing and final process, including without limitation quality assurance, reliability performance testing, and/or process qualification, may not yet be complete, and this item is subject to further changes or possible discontinuation. If available for ordering, purchases will be subject to an additional waiver at checkout, and are intended for early internal evaluation purposes only. These items are sold without warranties of any kind.

(3) **RoHS values:** Yes, No, RoHS Exempt. See the [TI RoHS Statement](#) for additional information and value definition.

(4) **Lead finish/Ball material:** Parts may have multiple material finish options. Finish options are separated by a vertical ruled line. Lead finish/Ball material values may wrap to two lines if the finish value exceeds the maximum column width.

(5) **MSL rating/Peak reflow:** The moisture sensitivity level ratings and peak solder (reflow) temperatures. In the event that a part has multiple moisture sensitivity ratings, only the lowest level per JEDEC standards is shown. Refer to the shipping label for the actual reflow temperature that will be used to mount the part to the printed circuit board.

**(6) Part marking:** There may be an additional marking, which relates to the logo, the lot trace code information, or the environmental category of the part.

Multiple part markings will be inside parentheses. Only one part marking contained in parentheses and separated by a "-" will appear on a part. If a line is indented then it is a continuation of the previous line and the two combined represent the entire part marking for that device.

**Important Information and Disclaimer:**The information provided on this page represents TI's knowledge and belief as of the date that it is provided. TI bases its knowledge and belief on information provided by third parties, and makes no representation or warranty as to the accuracy of such information. Efforts are underway to better integrate information from third parties. TI has taken and continues to take reasonable steps to provide representative and accurate information but may not have conducted destructive testing or chemical analysis on incoming materials and chemicals. TI and TI suppliers consider certain information to be proprietary, and thus CAS numbers and other limited information may not be available for release.

In no event shall TI's liability arising out of such information exceed the total purchase price of the TI part(s) at issue in this document sold by TI to Customer on an annual basis.

**TAPE AND REEL INFORMATION**

**QUADRANT ASSIGNMENTS FOR PIN 1 ORIENTATION IN TAPE**

\*All dimensions are nominal

Device	Package Type	Package Drawing	Pins	SPQ	Reel Diameter (mm)	Reel Width W1 (mm)	A0 (mm)	B0 (mm)	K0 (mm)	P1 (mm)	W (mm)	Pin1 Quadrant
ATL431AIDBZR	SOT-23	DBZ	3	3000	180.0	8.4	2.9	3.35	1.35	4.0	8.0	Q3
ATL431AQDBZR	SOT-23	DBZ	3	3000	180.0	8.4	2.9	3.35	1.35	4.0	8.0	Q3
ATL431AQDBZR	SOT-23	DBZ	3	3000	180.0	8.4	3.15	2.77	1.22	4.0	8.0	Q3
ATL431BIDBZR	SOT-23	DBZ	3	3000	180.0	8.4	3.15	2.77	1.22	4.0	8.0	Q3
ATL431BIDBZR	SOT-23	DBZ	3	3000	180.0	8.4	2.9	3.35	1.35	4.0	8.0	Q3
ATL431BQDBZR	SOT-23	DBZ	3	3000	180.0	8.4	2.9	3.35	1.35	4.0	8.0	Q3
ATL432AIDBZR	SOT-23	DBZ	3	3000	180.0	8.4	2.9	3.35	1.35	4.0	8.0	Q3
ATL432AQDBZR	SOT-23	DBZ	3	3000	180.0	8.4	3.15	2.77	1.22	4.0	8.0	Q3
ATL432AQDBZR	SOT-23	DBZ	3	3000	180.0	8.4	2.9	3.35	1.35	4.0	8.0	Q3
ATL432BIDBZR	SOT-23	DBZ	3	3000	180.0	8.4	2.9	3.35	1.35	4.0	8.0	Q3
ATL432BQDBZR	SOT-23	DBZ	3	3000	180.0	8.4	2.9	3.35	1.35	4.0	8.0	Q3

**TAPE AND REEL BOX DIMENSIONS**

\*All dimensions are nominal

Device	Package Type	Package Drawing	Pins	SPQ	Length (mm)	Width (mm)	Height (mm)
ATL431AIDBZR	SOT-23	DBZ	3	3000	210.0	185.0	35.0
ATL431AQDBZR	SOT-23	DBZ	3	3000	210.0	185.0	35.0
ATL431AQDBZR	SOT-23	DBZ	3	3000	183.0	183.0	20.0
ATL431BIDBZR	SOT-23	DBZ	3	3000	183.0	183.0	20.0
ATL431BIDBZR	SOT-23	DBZ	3	3000	210.0	185.0	35.0
ATL431BQDBZR	SOT-23	DBZ	3	3000	210.0	185.0	35.0
ATL432AIDBZR	SOT-23	DBZ	3	3000	210.0	185.0	35.0
ATL432AQDBZR	SOT-23	DBZ	3	3000	183.0	183.0	20.0
ATL432AQDBZR	SOT-23	DBZ	3	3000	210.0	185.0	35.0
ATL432BIDBZR	SOT-23	DBZ	3	3000	210.0	185.0	35.0
ATL432BQDBZR	SOT-23	DBZ	3	3000	210.0	185.0	35.0

# DBZ0003A



# PACKAGE OUTLINE

## SOT-23 - 1.12 mm max height

SMALL OUTLINE TRANSISTOR

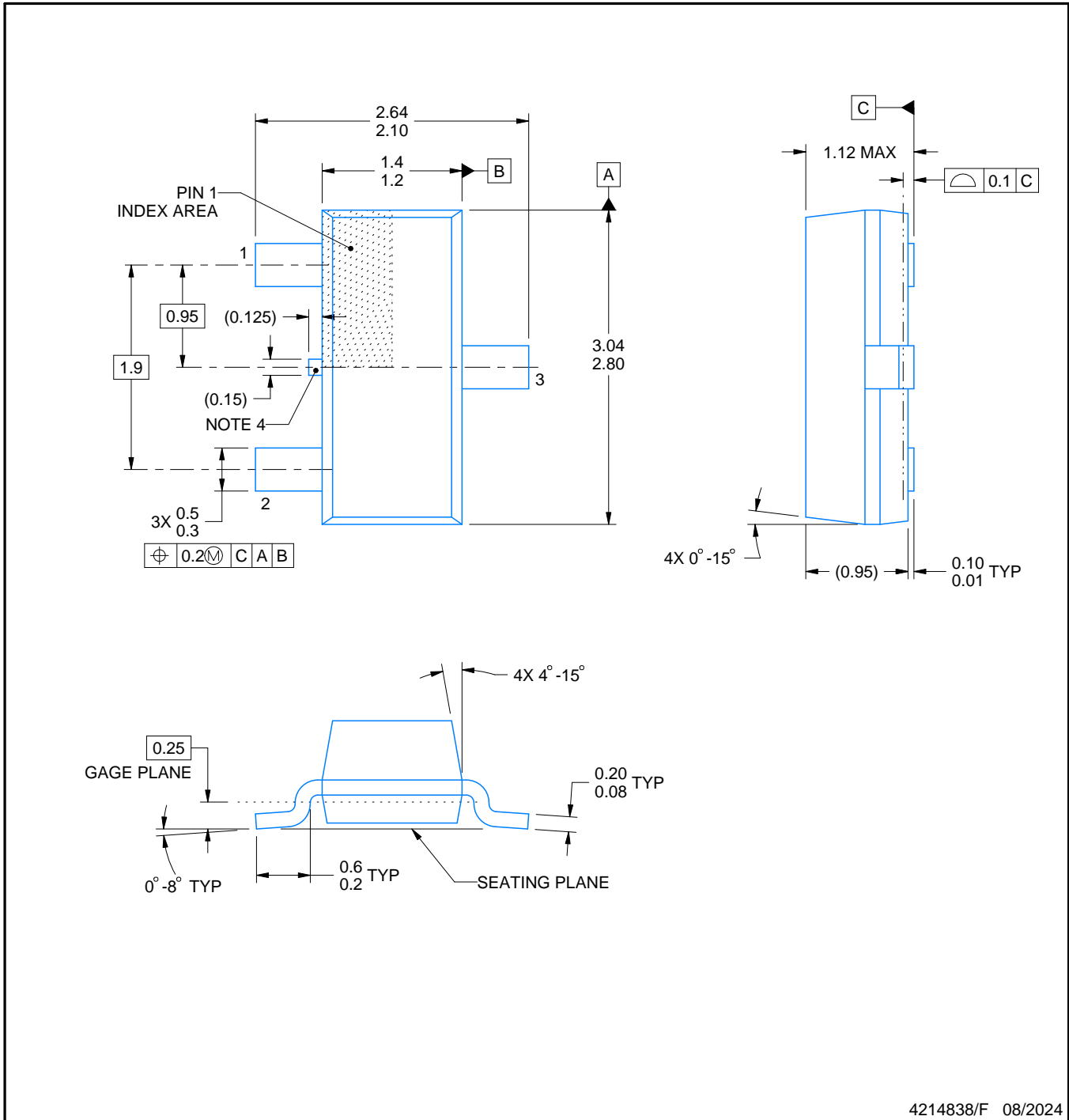

4214838/F 08/2024

### NOTES:

1. All linear dimensions are in millimeters. Any dimensions in parenthesis are for reference only. Dimensioning and tolerancing per ASME Y14.5M.
2. This drawing is subject to change without notice.
3. Reference JEDEC registration TO-236, except minimum foot length.
4. Support pin may differ or may not be present.
5. Body dimensions do not include mold flash, protrusions, or gate burrs. Mold flash, protrusions, or gate burrs shall not exceed 0.25mm per side

# EXAMPLE BOARD LAYOUT

DBZ0003A

SOT-23 - 1.12 mm max height

SMALL OUTLINE TRANSISTOR

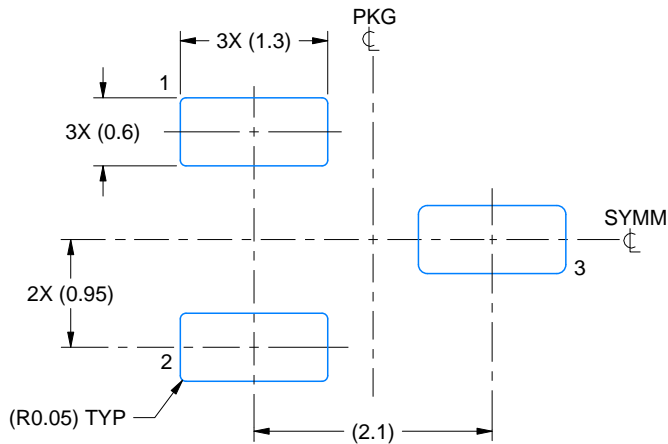

LAND PATTERN EXAMPLE  
SCALE:15X

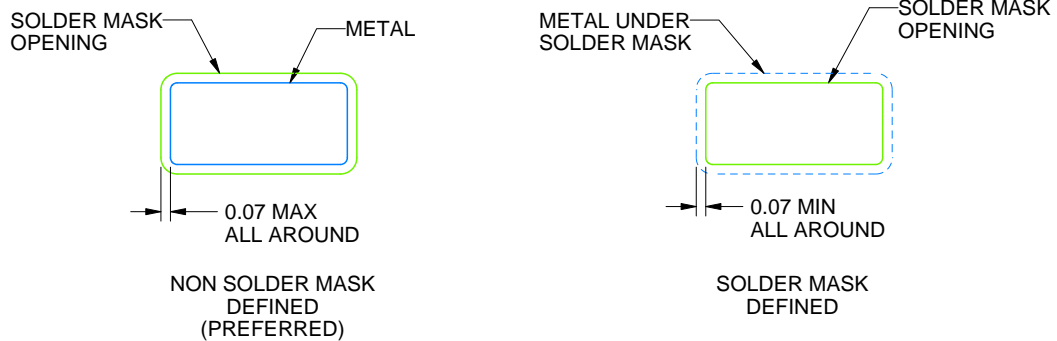

SOLDER MASK DETAILS

4214838/F 08/2024

NOTES: (continued)

5. Publication IPC-7351 may have alternate designs.
6. Solder mask tolerances between and around signal pads can vary based on board fabrication site.

# EXAMPLE STENCIL DESIGN

DBZ0003A

SOT-23 - 1.12 mm max height

SMALL OUTLINE TRANSISTOR

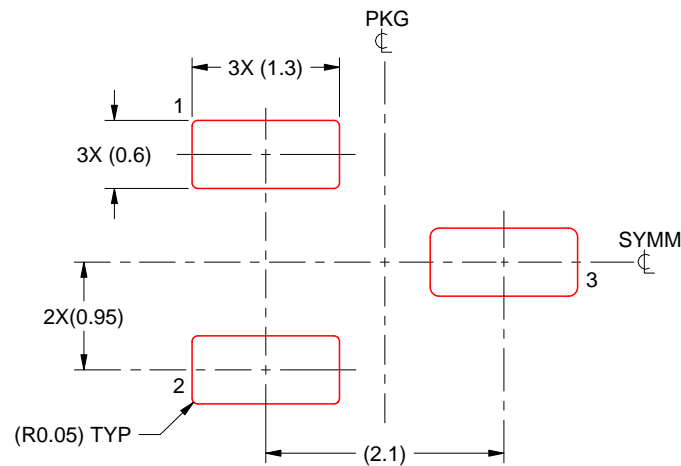

SOLDER PASTE EXAMPLE  
BASED ON 0.125 THICK STENCIL  
SCALE:15X

4214838/F 08/2024

NOTES: (continued)

7. Laser cutting apertures with trapezoidal walls and rounded corners may offer better paste release. IPC-7525 may have alternate design recommendations.
8. Board assembly site may have different recommendations for stencil design.

## IMPORTANT NOTICE AND DISCLAIMER

TI PROVIDES TECHNICAL AND RELIABILITY DATA (INCLUDING DATASHEETS), DESIGN RESOURCES (INCLUDING REFERENCE DESIGNS), APPLICATION OR OTHER DESIGN ADVICE, WEB TOOLS, SAFETY INFORMATION, AND OTHER RESOURCES "AS IS" AND WITH ALL FAULTS, AND DISCLAIMS ALL WARRANTIES, EXPRESS AND IMPLIED, INCLUDING WITHOUT LIMITATION ANY IMPLIED WARRANTIES OF MERCHANTABILITY, FITNESS FOR A PARTICULAR PURPOSE OR NON-INFRINGEMENT OF THIRD PARTY INTELLECTUAL PROPERTY RIGHTS.

These resources are intended for skilled developers designing with TI products. You are solely responsible for (1) selecting the appropriate TI products for your application, (2) designing, validating and testing your application, and (3) ensuring your application meets applicable standards, and any other safety, security, regulatory or other requirements.

These resources are subject to change without notice. TI grants you permission to use these resources only for development of an application that uses the TI products described in the resource. Other reproduction and display of these resources is prohibited. No license is granted to any other TI intellectual property right or to any third party intellectual property right. TI disclaims responsibility for, and you fully indemnify TI and its representatives against any claims, damages, costs, losses, and liabilities arising out of your use of these resources.

TI's products are provided subject to [TI's Terms of Sale](#), [TI's General Quality Guidelines](#), or other applicable terms available either on [ti.com](http://ti.com) or provided in conjunction with such TI products. TI's provision of these resources does not expand or otherwise alter TI's applicable warranties or warranty disclaimers for TI products. Unless TI explicitly designates a product as custom or customer-specified, TI products are standard, catalog, general purpose devices.

TI objects to and rejects any additional or different terms you may propose.

Copyright © 2026, Texas Instruments Incorporated

Last updated 10/2025