

BQ27Z855 Dynamic Z-Track™ Gauge with Integrated Protection, Current Limiter, and Authentication for 1 Cell Battery Packs

1 Features

- Fully integrated battery gas gauge, protector, current limiter, and authenticator
- Ultra-low power 32-bit RISC processor
- Battery chemistries supported include Li-ion with LCO, NMC, or LFP cathodes and with graphite or Si-anodes
- High-accuracy analog front end with two independent ADCs:
 - 18-bit low offset delta-sigma ADC for Coulomb counting with $\pm 100\text{mV}$ input range
 - 16-bit delta-sigma ADC for cell voltage and internal and external temperature sensors
 - Support for simultaneous current and voltage sampling
- High-side or low-side current sensing for system flexibility
- Battery fuel gauging based on patented Dynamic Z-Track™ technology
 - Models battery impedance for accurate time-to-empty predictions for static and dynamic loads
 - Automatically adjusts for aging, temperature, and rate-induced effects on the battery
- Programmable safety and protection:
 - Hardware- and firmware-level OVP, UVP, OCC, OCD, SCD protections
 - Overtemperature (OT) and undertemperature (UT) protections
- Integrated high efficiency high-side NMOS protection FET drivers
 - Current limiter with programmable CC-CV profile during charge mode
 - Ideal diode controller during discharge mode
- Up to 1MHz I²C bus communications interface with 1.2V- and 1.8V-level support
- ECC ECDSA and SHA-256 authentication support with secure memory
- Ultra-compact, 15-ball DSBGA package (YAH)

2 Applications

- Any end equipment with 1-series rechargeable batteries:
 - Smartphones and foldable smartphones
 - Tablets
 - VR headsets
 - Personal electronics
 - Hearables
 - Portable wearables/medical

3 Description

The Texas Instruments BQ27Z855 Dynamic Z-Track™ gas gauge solution is a fully integrated, accurate 1-series cell gas gauge, protection, current limiter, and authentication solution.

The BQ27Z855 device provides a fully integrated pack-based solution with a flash programmable reduced instruction-set CPU (RISC), safety protection, current limiter, ideal diode controller, and authentication for 1-series cell Li-ion and Li-polymer battery packs.

The BQ27Z855 gas gauge communicates through an I²C compatible interface and combines an ultra-low power RISC processor, high accuracy analog measurement capabilities, integrated flash memory, high-side NMOS FET drivers, and ECC ECDSA and SHA-2 authentication to provide a complete, high-performance battery management solution.

Package Information

PART NUMBER	PACKAGE ⁽¹⁾	PACKAGE SIZE ⁽²⁾
BQ27Z855	DSBGA (YAH, 15)	1.51mm × 2.55mm

- For all available packages, see the orderable addendum at the end of the data sheet.
- The package size (length × width) is a nominal value and includes pins, where applicable.

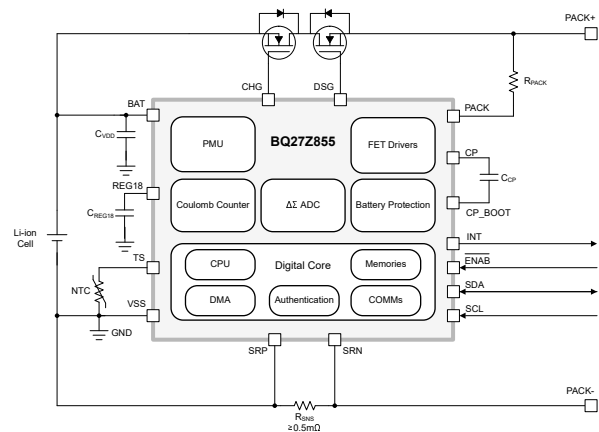

BQ27Z855 Simplified Schematic

Table of Contents

1 Features	1	5.21 Zero-volt Charging (ZVCHG).....	11
2 Applications	1	5.22 General Purpose Input-Outputs (INT).....	12
3 Description	1	5.23 I ² C Interface I/O (SDA, SCL).....	12
4 Pin Configurations and Functions	3	5.24 I ² C Interface Timing.....	12
5 Specifications	4	6 Detailed Description	15
5.1 Absolute Maximum Ratings.....	4	6.1 Overview.....	15
5.2 ESD Ratings.....	4	6.2 Functional Block Diagram.....	16
5.3 Recommended Operating Conditions.....	4	6.3 Feature Description.....	17
5.4 Supply Current.....	5	6.4 Device Functional Modes.....	34
5.5 1.8V LDO Regulator (REG18).....	5	7 Application and Implementation	35
5.6 Low Frequency Oscillator (LFO).....	6	7.1 Application Information.....	35
5.7 High Frequency Oscillator (HFO).....	6	7.2 Typical Application Schematics.....	35
5.8 PACK Clamp (PACK_CLAMP).....	6	8 Power Supply Recommendations	53
5.9 Analog-to-Digital Converter (VADC).....	7	9 Layout	53
5.10 Coulomb Counter (CCADC).....	7	9.1 Layout Guidelines.....	53
5.11 Coulomb Counter Digital Filter (CC1).....	7	10 Device and Documentation Support	54
5.12 Current Measurement Digital Filter (CC2).....	8	10.1 Third-Party Products Disclaimer.....	54
5.13 Charge Current Measurement Digital Filter (CC3).....	8	10.2 Documentation Support.....	54
5.14 Wake-up Comparator (I-WAKE).....	8	10.3 Trademarks.....	54
5.15 Internal Temperature Sensor (INT_TEMP).....	8	10.4 Electrostatic Discharge Caution.....	54
5.16 Thermistor Measurement Support.....	9	10.5 Glossary.....	54
5.17 Hardware-based Protection (SCOMP)		11 Revision History	54
Thresholds (OVP, UVP, OCC, OCD, SCD).....	9	12 Mechanical, Packaging, and Orderable	
5.18 Hardware-based Protections (SCOMP) Timing		Information	55
(OVP, UVP, OCC, OCD, SCD).....	10	12.1 Tape and Reel Information.....	57
5.19 Current Limiter.....	10	12.2 Mechanical Data.....	59
5.20 CHG, DSG NFET Drivers.....	11		

4 Pin Configurations and Functions

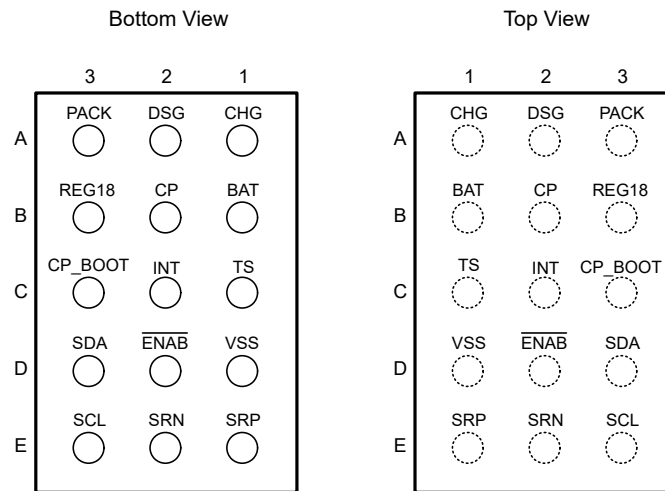

Table 4-1. Pin Functions

PIN			DESCRIPTION
NAME	NO.	TYPE ⁽¹⁾	
CHG	A1	AO	High-side NMOS charge FET driver output
DSG	A2	AO	High-side NMOS discharge FET driver output
PACK	A3	AI	Pack input voltage sensing pin and path for zero-volt charge (ZVCHG) current to flow within the device from PACK to BAT. Connect a series 1kΩ typical resistor (R_{PACK}) between the PACK pin and the PACK+ positive terminal.
BAT	B1	P, AI	LDO regulator input and battery voltage measurement sense input. Connect a capacitor (C_{BAT}) with the recommended typical capacitance of 1μF between BAT and VSS. Place the capacitor close to the gauge.
CP	B2	AO	Internal charge pump connection to the top of an external bypass capacitor (C_{CP}) with the recommended typical capacitance of 1μF. Connect the capacitor between CP and CP_BOOT. Place the capacitor close to the gauge.
REG18	B3	P	Internal regulator output. Requires a capacitor (C_{REG18}) with the recommended typical capacitance of 1.5μF connected between REG18 and VSS. Place the capacitor close to the gauge.
TS	C1	AI	Thermistor input to VADC with internal 18 kΩ pull-up resistor. If not used, connect directly to VSS or leave floating and configure data flash accordingly.
INT	C2	I/O	Programmable output interrupt to host. Can also be configured as a programmable push-pull GPIO via device firmware. If not used, leave floating and configure data flash accordingly.
CP_BOOT	C3	AO	Internal charge pump connection to the bottom of an external bypass capacitor (C_{CP}) with the recommended typical capacitance of 1μF. Connect the capacitor between CP and CP_BOOT. Place the capacitor close to the gauge.
VSS	D1	P	Device ground
ENAB	D2	I	Active low digital input with weak internal pull-up to BAT. Driving this signal to the PACK- battery pack terminal while the device is in a SHELF or SHUTDOWN mode will enable the device to wake up.
SDA	D3	I/O	Digital input, open drain output for I ² C serial data
SRP	E1	AI	Analog input pin connected to the internal Coulomb counter peripheral for integrating a small voltage between SRP and SRN, where SRP is the top of the sense resistor. A charging current generates a positive voltage at SRP relative to SRN.
SRN	E2	AI	Analog input pin connected to the internal Coulomb counter peripheral for integrating a small voltage between SRP and SRN, where SRN is the bottom of the sense resistor. A charging current generates a positive voltage at SRP relative to SRN.
SCL	E3	I/O	Digital input, open drain output for I ² C serial clock

(1) I/O = Digital Input/Output, AI = Analog Input, AO = Analog Output, P = Power

5 Specifications

5.1 Absolute Maximum Ratings

Over operating free-air temperature range (unless otherwise noted)⁽¹⁾

		MIN	MAX	UNIT
Supply voltage range, V_{CC}	BAT	-0.3	6	V
Input voltage range, V_{IN}	BAT	-0.3	6	V
	PACK (no R_{PACK})	-0.3	7	
	PACK+ external battery pack input terminal with 1k Ω resistor in series to device PACK input pin	-0.3	24	
	ENAB	-0.3	6	
	SDA, SCL	-0.3	6	
	INT, TS	-0.3	6	
	SRP, SRN	-0.3	$V_{BAT} + 0.3$	
Output voltage range, V_{OUT}	CHG, DSG	-0.3	8.5	V
	CP	-0.3	8.5	
	CP_BOOT	-0.3	2.1	
Output voltage range, V_{REG18}	REG18	-0.3	2	V
Junction temperature, T_J			105	°C
Storage temperature, T_{stg}		-65	150	°C

- (1) Stresses beyond those listed under Absolute Maximum Ratings may cause permanent damage to the device. These are stress ratings only, which do not imply functional operation of the device at these or any other conditions beyond those indicated under Recommended Operating Conditions. Exposure to absolute-maximum-rated conditions for extended periods may affect device reliability.

5.2 ESD Ratings

		VALUE	UNIT
V_{ESD}	Electrostatic discharge	Human body model (HBM), per ANSI/ESDA/JEDEC JS-001 ⁽¹⁾	±1500
		Charged device model (CDM), per ANSI/ESDA/JEDEC JS-002 ⁽²⁾	±500

- (1) JEDEC document JEP155 states that 500V HBM allows safe manufacturing with a standard ESD control process.

- (2) JEDEC document JEP157 states that 250V CDM allows safe manufacturing with a standard ESD control process.

5.3 Recommended Operating Conditions

Typical values stated where $T_A = 25^\circ\text{C}$ and $V_{BAT} = 3.8\text{V}$, MIN/MAX values stated where $T_A = -40^\circ\text{C}$ to 85°C and $V_{BAT} = 2.0\text{V}$ to 5.0V (unless otherwise noted)

		TEST CONDITIONS	MIN	NOM	MAX	UNIT
V_{CC}	Supply voltage range	BAT	2.0		5.5	V
V_{IN}	Input voltage range	BAT	1.5		5.5	V
		PACK (with 1k Ω R_{PACK} current limit)	0		6	
		PACK (no R_{PACK} current limit)	0		5.5	
		ENAB	-0.3		BAT	
		SDA, SCL	-0.3		3.6	
		TS	V_{SS}		V_{REG18}	
		SRP, SRN	V_{CCADC_CM} -0.1		V_{CCADC_CM} +0.1	

Typical values stated where $T_A = 25^\circ\text{C}$ and $V_{BAT} = 3.8\text{V}$, MIN/MAX values stated where $T_A = -40^\circ\text{C}$ to 85°C and $V_{BAT} = 2.0\text{V}$ to 5.0V (unless otherwise noted)

		TEST CONDITIONS	MIN	NOM	MAX	UNIT
V_{OUT}	Output voltage range	INT	0		V_{REG18}	V
		CHG, DSG	V_{SS}		$V_{FET_ON(MAX)}$	
C_{BAT} (1)	External decoupling capacitor on BAT pin	Derated capacitance	0.5	1		μF
C_{REG18} (1)	External decoupling capacitor on REG18 pin	Derated capacitance	1	1.5	2	μF
C_{TS} (1)	External decoupling capacitor on TS pin	Derated capacitance			0.01	μF
C_{CP} (1)	External bypass capacitor between CP and CP_BOOT pins	Derated capacitance	0.5	1	2	μF
R_{PACK} (1)	External resistor from PACK+ terminal to device PACK pin	Nominal resistance, MIN/MAX is $\pm 5\%$ tolerance of nominal	0.95		3.15	k Ω
R_{SENSE} (1)	External sense resistor between SRP and SRN pins		0.5			m Ω
T_A	Operating temperature	Operating ambient tempeprature	-40		85	$^\circ\text{C}$

(1) Specified by Design. Not production tested.

5.4 Supply Current

Typical values stated where $T_A = 25^\circ\text{C}$ and $V_{BAT} = 3.8\text{V}$, MIN/MAX values stated where $T_A = -40^\circ\text{C}$ to 85°C and $V_{BAT} = 2.0\text{V}$ to 5.0V (unless otherwise noted)

PARAMETER		TEST CONDITIONS	MIN	TYP	MAX	UNIT
I_{ACTIVE} (1) (2)	ACTIVE mode	$V_{BAT} = 4\text{V}$, CHG ON, DSG ON, No I ² C communication		40		μA
I_{SLEEP} (1) (2)	SLEEP mode	Measured Current \leq Sleep Current (3), $V_{BAT} = 4\text{V}$, CHG ON, DSG ON, No I ² C communication		30		μA
$I_{DEEP\ SLEEP}$ (1) (2)	DEEP SLEEP mode	Measured Current \leq Deep Sleep Current (3), $V_{BAT} = 4\text{V}$, CHG ON, DSG ON, No I ² C communication		20		μA
I_{SHELF1} (1) (2)	SHELF1 mode	SHELF1 mode enabled, $V_{BAT} = 4\text{V}$, CHG OFF, DSG OFF		4		μA
I_{SHELF2} (1) (2)	SHELF2 mode	SHELF2 mode enabled, $V_{BAT} = 4\text{V}$, CHG OFF, DSG OFF, LFO ON for timekeeping, Wakeup via PACK detection and ENAB pin enabled		2		μA
$I_{SHUTDOWN}$ (1)	SHUTDOWN mode	SHUTDOWN mode enabled or $V_{BAT} <$ Shutdown Voltage (3), Wakeup via PACK detection and ENAB pin enabled		0.2		μA

(1) Specified by Bench Evaluation with device firmware. Not production tested.

(2) Average current over 60s with default firmware settings. Device power consumption dependent on firmware configuration.

(3) Firmware-based parameter. The data flash configuration value can be changed in FULL ACCESS mode and is locked in SEALED mode. Refer to the BQ27Z855 Technical Reference Manual.

5.5 1.8V LDO Regulator (REG18)

Typical values stated where $T_A = 25^\circ\text{C}$ and $V_{BAT} = 3.8\text{V}$, MIN/MAX values stated where $T_A = -40^\circ\text{C}$ to 85°C and $V_{BAT} = 2.0\text{V}$ to 5.0V (unless otherwise noted)

PARAMETER		TEST CONDITIONS	MIN	TYP	MAX	UNIT
V_{REG18}	Regulator output voltage	During device power-up	1.6	1.8	2.0	V
		After device power-up	1.74	1.8	1.86	

Typical values stated where $T_A = 25^\circ\text{C}$ and $V_{BAT} = 3.8\text{V}$, MIN/MAX values stated where $T_A = -40^\circ\text{C}$ to 85°C and $V_{BAT} = 2.0\text{V}$ to 5.0V (unless otherwise noted)

PARAMETER		TEST CONDITIONS	MIN	TYP	MAX	UNIT
$\Delta V_{REG18TEMP}^{(2)}$	Regulator output change with temperature, $\Delta V_{REG18}/V_{REG18}$	$I_{REG18} = 1\text{mA}$	-1.7		1.1	%
$\Delta V_{REG18LINE}$	Line regulation, $\Delta V_{REG18}/\Delta V_{BAT}$	$I_{REG18} = 1\text{mA}$	-0.25		0.25	%
$\Delta V_{REG18LOAD}$	Load regulation, $\Delta V_{REG18}/\Delta I_{REG18}$	$I_{REG18} = 1$ to 16mA	-1.5		1.0	%
I_{REG18_SHORT}	Short circuit current limit	$V_{REG18} = 0\text{V}$	16		65	mA
V_{POR_TH}	POR threshold	Rising threshold	1.55	1.75	1.90	V
V_{POR_HYS}	POR hysteresis		105	115	125	mV
$V_{ENAB}^{(1)}$	\overline{ENAB} pin voltage for device wake-up from SHELFB1, SHELFB2, or SHUTDOWN state	Active low falling threshold			0.65	V
$R_{ENAB}^{(1)}$	\overline{ENAB} pin pull-up resistance			1		M Ω
$V_{STARTUP}^{(1)}$	Minimum PACK pin voltage for device wake-up from SHELFB1, SHELFB2, or SHUTDOWN state			2.0		V

- (1) Specified by Design. Not production tested.
 (2) Specified by Characterization. Not production tested.

5.6 Low Frequency Oscillator (LFO)

Typical values stated where $T_A = 25^\circ\text{C}$ and $V_{BAT} = 3.8\text{V}$, MIN/MAX values stated where $T_A = -40^\circ\text{C}$ to 85°C and $V_{BAT} = 2.0\text{V}$ to 5.0V (unless otherwise noted)

PARAMETER		TEST CONDITIONS	MIN	TYP	MAX	UNIT
F_{LFO}	Operating frequency			65.536		kHz
$F_{LFO_DRIFT}^{(1)(2)}$	Frequency drift		-2.5		2.5	%

- (1) Specified by Characterization. Not production tested.
 (2) The frequency drift is included and measured from the trimmed frequency at $T_A = 25^\circ\text{C}$, with the minimum and maximum based on characterization, actual value stored in OTP

5.7 High Frequency Oscillator (HFO)

Typical values stated where $T_A = 25^\circ\text{C}$ and $V_{BAT} = 3.8\text{V}$, MIN/MAX values stated where $T_A = -40^\circ\text{C}$ to 85°C and $V_{BAT} = 2.0\text{V}$ to 5.0V (unless otherwise noted)

PARAMETER		TEST CONDITIONS	MIN	TYP	MAX	UNIT
F_{HFO}	Operating frequency			16.384		MHz
$F_{HFO_DRIFT}^{(1)(2)}$	Frequency drift	$T_A = -25^\circ\text{C}$ to 65°C	-2		2	%
		$T_A = -40^\circ\text{C}$ to 85°C	-3.5		3.5	

- (1) Specified by Characterization. Not production tested.
 (2) The frequency drift is included and measured from the trimmed frequency at $T_A = 25^\circ\text{C}$, with the minimum and maximum based on characterization, actual value stored in OTP

5.8 PACK Clamp (PACK_CLAMP)

Typical values stated where $T_A = 25^\circ\text{C}$ and $V_{BAT} = 3.8\text{V}$, MIN/MAX values stated where $T_A = -40^\circ\text{C}$ to 85°C and $V_{BAT} = 2.0\text{V}$ to 5.0V (unless otherwise noted)

PARAMETER		TEST CONDITIONS	MIN	TYP	MAX	UNIT
V_{PACK_CLAMP}	Rising voltage on PACK when clamp is active	$I_{PACK_CLAMP} < 1\text{mA}$, $R_{PACK} = 1\text{k}\Omega$	5.5		7	V
$I_{PACK_CLAMP_PEAK}^{(2)}$	Peak clamp current when clamp fully active	For a time $< 2.5\text{ms}$, $R_{PACK} = 1\text{k}\Omega$			22	mA

Typical values stated where $T_A = 25^\circ\text{C}$ and $V_{\text{BAT}} = 3.8\text{V}$, MIN/MAX values stated where $T_A = -40^\circ\text{C}$ to 85°C and $V_{\text{BAT}} = 2.0\text{V}$ to 5.0V (unless otherwise noted)

PARAMETER		TEST CONDITIONS	MIN	TYP	MAX	UNIT
$I_{\text{PACK_CLAMP_ON}}$ (1)	Clamp current when clamp fully active	$R_{\text{PACK}} = 1\text{k}\Omega$		18	19	mA

- (1) Specified by Characterization. Not production tested.
(2) Specified by Bench Evaluation. Not production tested.

5.9 Analog-to-Digital Converter (VADC)

Typical values stated where $T_A = 25^\circ\text{C}$ and $V_{\text{BAT}} = 3.8\text{V}$, MIN/MAX values stated where $T_A = -40^\circ\text{C}$ to 85°C and $V_{\text{BAT}} = 2.0\text{V}$ to 5.0V (unless otherwise noted)

PARAMETER		TEST CONDITIONS	MIN	TYP	MAX	UNIT
$V_{\text{BAT_FS}}$	Battery voltage measurement full scale range	$V_{\text{IN}} = V_{\text{BAT}}$	-0.2		5.5	V
$V_{\text{BAT_ERR}}$	Battery voltage measurement error	$V_{\text{IN}} = V_{\text{BAT}}$, $T_A = 25^\circ\text{C}$, $V_{\text{BAT}} = 2.5$ to 5.0V , Post-Calibration	-4	± 2	4	mV
$V_{\text{TS_FS}}$	External thermistor voltage measurement full scale range	$V_{\text{IN}} = V_{\text{TS}}$	-0.2		V_{REG18}	V
$t_{\text{ADC_CONV}}$ (4)	Conversion time	Single conversion		11.72		ms
$B_{\text{ADC_ER}}$ (2) (3)	Effective resolution	Single conversion	14	15		bits
$R_{\text{VADC_IN}}$ (1)	Effective input resistance			8		$\text{M}\Omega$

- (1) Specified by Design. Not production tested.
(2) Specified by Characterization. Not production tested.
(3) Effective Resolution is defined as the resolution such that the data exhibits 1-sigma variation within ± 1 -LSB.
(4) Timing accuracy is relative to F_{LFO} accuracy

5.10 Coulomb Counter (CCADC)

Typical values stated where $T_A = 25^\circ\text{C}$ and $V_{\text{BAT}} = 3.8\text{V}$, MIN/MAX values stated where $T_A = -40^\circ\text{C}$ to 85°C and $V_{\text{BAT}} = 2.0\text{V}$ to 5.0V (unless otherwise noted)

PARAMETER		TEST CONDITIONS	MIN	TYP	MAX	UNIT
$V_{\text{CCADC_IN}}$ (3)	Input voltage range		-100		100	mV
$V_{\text{CCADC_CM}}$	Common mode voltage range	$V_{\text{SS}} = 0\text{V}$, $2\text{V} \leq V_{\text{BAT}} \leq 5\text{V}$	V_{SS}		V_{BAT}	V
$V_{\text{CCADC_IN}}$	Input voltage range with common mode voltage range		$V_{\text{CCADC_CM}} - 0.1$		$V_{\text{CCADC_CM}} + 0.1$	V
$V_{\text{CCADC_OFF}}$ (2)	Offset error	18-bit, $T_A = 25^\circ\text{C}$, Post-Calibration	-2		2	LSB(3)
$R_{\text{CCADC_IN}}$ (1)	Effective input resistance			1.5		$\text{M}\Omega$

- (1) Specified by Design. Not production tested.
(2) Specified by Characterization. Not production tested.
(3) The LSB size for an 18-bit, 1000ms CCADC result is 923nV

5.11 Coulomb Counter Digital Filter (CC1)

Typical values stated where $T_A = 25^\circ\text{C}$ and $V_{\text{BAT}} = 3.8\text{V}$, MIN/MAX values stated where $T_A = -40^\circ\text{C}$ to 85°C and $V_{\text{BAT}} = 2.0\text{V}$ to 5.0V (unless otherwise noted)

PARAMETER		TEST CONDITIONS	MIN	TYP	MAX	UNIT
$t_{\text{CC1_CONV}}$ (4)	Conversion time	Single conversion		1000		ms
$B_{\text{CC1_ER}}$ (1) (2) (3)	Effective resolution	Single conversion		18		bits

- (1) Specified by Characterization. Not production tested.
(2) Effective Resolution is defined as the resolution such that the data exhibits 1-sigma variation within ± 1 -LSB.
(3) Input signal DC = $\pm 1\text{mV}$, Harmonic Free Full Scale

(4) Timing accuracy is relative to F_{LFO} accuracy

5.12 Current Measurement Digital Filter (CC2)

Typical values stated where $T_A = 25^\circ\text{C}$ and $V_{BAT} = 3.8\text{V}$, MIN/MAX values stated where $T_A = -40^\circ\text{C}$ to 85°C and $V_{BAT} = 2.0\text{V}$ to 5.0V (unless otherwise noted)

PARAMETER		TEST CONDITIONS	MIN	TYP	MAX	UNIT
t_{CC2_CONV} (4)	Conversion time	Single conversion		11.72		ms
B_{CC2_ER} (1) (2) (3)	Effective resolution	Single conversion	14	15		bits

- (1) Specified by Characterization. Not production tested.
- (2) Effective Resolution is defined as the resolution such that the data exhibits 1-sigma variation within $\pm 1\text{-LSB}$.
- (3) Input signal DC = $\pm 1\text{mV}$, Harmonic Free Full Scale
- (4) Timing accuracy is relative to F_{LFO} accuracy

5.13 Charge Current Measurement Digital Filter (CC3)

Typical values stated where $T_A = 25^\circ\text{C}$ and $V_{BAT} = 3.8\text{V}$, MIN/MAX values stated where $T_A = -40^\circ\text{C}$ to 85°C and $V_{BAT} = 2.0\text{V}$ to 5.0V (unless otherwise noted)

PARAMETER		TEST CONDITIONS	MIN	TYP	MAX	UNIT
t_{CC3_CONV} (4)	Conversion time	Single conversion		11.72		ms
B_{CC3_ER} (1) (2) (3)	Effective resolution	Single conversion	14	15		bits

- (1) Specified by Characterization. Not production tested.
- (2) Effective Resolution is defined as the resolution such that the data exhibits 1-sigma variation within $\pm 1\text{-LSB}$.
- (3) Input signal DC = $\pm 1\text{mV}$, Harmonic Free Full Scale
- (4) Timing accuracy is relative to F_{LFO} accuracy

5.14 Wake-up Comparator (I-WAKE)

Typical values stated where $T_A = 25^\circ\text{C}$ and $V_{BAT} = 3.8\text{V}$, MIN/MAX values stated where $T_A = -40^\circ\text{C}$ to 85°C and $V_{BAT} = 2.0\text{V}$ to 5.0V (unless otherwise noted)

PARAMETER		TEST CONDITIONS	MIN	TYP	MAX	UNIT
V_{WAKE_THR} (1) (3)	Wake-up voltage threshold range	Nominal settings, threshold based on $V_{SRP} - V_{SRN}$, 0.5mV steps, typical value is default threshold	-7.5	± 4.5	7.5	mV
$V_{WAKE_THR_ERR}$ (2)	Wake-up voltage threshold error	All V_{WAKE_THR} settings, $V_{WAKE} = V_{SRP} - V_{SRN}$	-250		250	μV

- (1) Specified by Design. Not production tested.
- (2) Specified by Characterization. Not production tested.
- (3) Specified typical value is the factory default setting. The setting in data flash can be changed in FULL ACCESS mode and is locked in SEALED mode. Refer to the BQ27Z855 Technical Reference Manual.

5.15 Internal Temperature Sensor (INT_TEMP)

Typical values stated where $T_A = 25^\circ\text{C}$ and $V_{BAT} = 3.8\text{V}$, MIN/MAX values stated where $T_A = -40^\circ\text{C}$ to 85°C and $V_{BAT} = 2.0\text{V}$ to 5.0V (unless otherwise noted)

PARAMETER		TEST CONDITIONS	MIN	TYP	MAX	UNIT
V_{INT_TEMP} (1)	Internal temperature sensor voltage drift	V_{INT_TEMP}	-1.88	-1.83	-1.74	$\text{mV}/^\circ\text{C}$

- (1) Specified by Characterization. Not production tested.

5.16 Thermistor Measurement Support

Typical values stated where $T_A = 25^\circ\text{C}$ and $V_{BAT} = 3.8\text{V}$, MIN/MAX values stated where $T_A = -40^\circ\text{C}$ to 85°C and $V_{BAT} = 2.0\text{V}$ to 5.0V (unless otherwise noted)

PARAMETER		TEST CONDITIONS	MIN	TYP	MAX	UNIT
R_{TS_PU}	Internal pull-up resistance	Setting for nominal 18k Ω	14.4	18	21.6	k Ω
$R_{TS_PU_DRIFT}$ (1)	Resistance drift over temperature	Change over -40°C to $+85^\circ\text{C}$ vs value at 25°C for nominal 18-k Ω	-200		200	Ω

(1) Specified by Characterization. Not production tested.

5.17 Hardware-based Protection (SCOMP) Thresholds (OVP, UVP, OCC, OCD, SCD)

Typical values stated where $T_A = 25^\circ\text{C}$ and $V_{BAT} = 3.8\text{V}$, MIN/MAX values stated where $T_A = -40^\circ\text{C}$ to 85°C and $V_{BAT} = 2.0\text{V}$ to 5.0V (unless otherwise noted)

PARAMETER		TEST CONDITIONS	MIN	TYP	MAX	UNIT
V_{OVP} (1) (4)	Hardware overvoltage protection (OVP) detection range	$V_{IN} = V_{BAT}$, threshold range, 50mV steps, typical value is default	3500	4300	5000	mV
V_{OVP_ACC} (2) (3)	Hardware OVP detection accuracy	$V_{IN} = V_{BAT}$, $T_A = 0^\circ\text{C}$ to 60°C , C_{LOAD} at CHG/DSG < 1 μA	-25		25	mV
		$V_{IN} = V_{BAT}$, $T_A = -40^\circ\text{C}$ to 85°C , C_{LOAD} at CHG/DSG < 1 μA	-50		50	mV
V_{UVP} (1) (4)	Hardware undervoltage protection (UVP) detection range	$V_{IN} = V_{BAT}$, threshold range, 50mV steps, typical value is default	2000	2300	4000	mV
V_{UVP_ACC} (2) (3)	Hardware UVP detection accuracy	$V_{IN} = V_{BAT}$, $T_A = 0^\circ\text{C}$ to 60°C , C_{LOAD} at CHG/DSG < 1 μA	-30		30	mV
		$V_{IN} = V_{BAT}$, $T_A = -40^\circ\text{C}$ to 85°C , C_{LOAD} at CHG/DSG < 1 μA	-50		50	mV
R_{PACK_VSS}	Resistance between PACK and VSS	SHELF2 and SHUTDOWN modes only	100	300	550	k Ω
V_{OCC} (1) (4)	Hardware overcurrent in charge (OCC) detection range	$V_{IN} = V_{SRP} - V_{SRN}$, threshold range, 1mV steps, typical value is default	4	14	100	mV
V_{OCD} (1) (4)	Hardware overcurrent in discharge (OCD) detection range	$V_{IN} = V_{SRP} - V_{SRN}$, threshold range, 1mV steps, typical value is default	-4	-16	-100	mV
V_{SCD} (1) (4)	Hardware short circuit current in discharge (SCD) detection range	$V_{IN} = V_{SRP} - V_{SRN}$, threshold range, 1mV steps, typical value is default	-5	-20	-120	mV
V_{OCC_ACC} (2)	Overcurrent (OCC, OCD, SCD) detection accuracy	$V_{IN} = V_{SRP} - V_{SRN}$, Setting < 20mV, $T_A = -25^\circ\text{C}$ to 65°C	-2.1		2.1	mV
		$V_{IN} = V_{SRP} - V_{SRN}$, Setting < 20mV	-2.1		2.1	mV
		$V_{IN} = V_{SRP} - V_{SRN}$, Setting = 20 to 55mV	-3		3	mV
		$V_{IN} = V_{SRP} - V_{SRN}$, Setting = 56 to 100mV	-5		5	mV
		$V_{IN} = V_{SRP} - V_{SRN}$, Setting > 100mV	-12		12	mV

(1) Specified by Design. Not production tested.

(2) Specified by Characterization. Not production tested.

(3) Accuracy assured by specified default threshold.

(4) Specified typical value is the factory default setting. The setting in data flash can be changed in FULL ACCESS mode and is locked in SEALED mode. Refer to the BQ27Z855 Technical Reference Manual.

5.18 Hardware-based Protections (SCOMP) Timing (OVP, UVP, OCC, OCD, SCD)

Typical values stated where $T_A = 25^\circ\text{C}$ and $V_{\text{BAT}} = 3.8\text{V}$, MIN/MAX values stated where $T_A = -40^\circ\text{C}$ to 85°C and $V_{\text{BAT}} = 2.0\text{V}$ to 5.0V (unless otherwise noted)

PARAMETER	TEST CONDITIONS	MIN	TYP	MAX	UNIT	
t_{OVP} (1) (2) (3)	OVP detection delay options	Configurable with 8191 delay options in 854 μs steps. Factory default = 1171 counts = 1s typical	0.854	1000	6999	ms
t_{UVP} (1) (2) (3)	UVP detection delay options	Configurable with 255 delay options in 854 μs steps. Factory default = 117 counts = 100ms typical	0.854	100	218	ms
t_{OCC} (1) (2) (3)	OCC detection delay options	Configurable with 127 delay options in 854 μs steps. Factory default = 10 counts = 8.5ms typical	0.854	8.5	109	ms
t_{OCD} (1) (2) (3)	OCD detection delay options	Configurable with 127 delay options in 854 μs steps. Factory default = 18 counts = 15.4ms typical	0.854	15.4	109	ms
t_{SCD} (1) (2) (3)	SCD detection delay options	Configurable with 7 delay options in 122 μs steps. Factory default = 1 counts = 122 μs typical	0	122	732	μs
$t_{\text{WAKE_CC}}$ (1) (2) (3)	Current wake in charge detection delay options	Configurable with 31 delay options in 854 μs steps. Factory default = 7 counts = 6.0ms typical	0.854	6.0	26.5	ms
$t_{\text{WAKE_CD}}$ (1) (2) (3)	Current wake in discharge detection delay options	Configurable with 31 delay options in 854 μs steps. Factory default = 14 counts = 12.0ms typical	0.854	12.0	26.5	ms

(1) Specified by Bench Evaluation. Not production tested.

(2) Specified typical value is the factory default setting. The setting in data flash can be changed in FULL ACCESS mode and is locked in SEALED mode. Refer to the BQ27Z855 Technical Reference Manual.

(3) Not including LFO Frequency Error

5.19 Current Limiter

Typical values stated where $T_A = 25^\circ\text{C}$ and $V_{\text{BAT}} = 3.8\text{V}$, MIN/MAX values stated where $T_A = -40^\circ\text{C}$ to 85°C and $V_{\text{BAT}} = 2.0\text{V}$ to 5.0V (unless otherwise noted)

PARAMETER	TEST CONDITIONS	MIN	TYP	MAX	UNIT	
Constant Voltage (CV) Regulation						
$V_{\text{BAT_REG_RN}}^{\text{G}}$ (1) (4)	BAT charge voltage regulation range	Firmware programmable range, 10mV steps	3500	4200	4650	mV
$V_{\text{BAT_REG_ACC}}$ (2)	BAT charge voltage accuracy	All $V_{\text{BAT_REG}}$ settings, typical measurement at $V_{\text{BAT_REG}} = 4200\text{mV}$	-0.5		0.5	%
Constant Current (CC) Regulation						
$I_{\text{CHG_RNG}}$ (1) (3) (4)	Charge current regulation range	Firmware programmable range	5		2000	mA
$I_{\text{CHG_ACC}}$ (2)	Charge current accuracy	$V_{\text{SRP}} - V_{\text{SRN}}$, $I_{\text{CHG}} = 50\text{mA}$, $R_{\text{SENSE}} = 10\text{m}\Omega$, Post-Calibration	45	50	55	mA
$I_{\text{CHG_ACC}}$ (2)	Charge current accuracy	$V_{\text{SRP}} - V_{\text{SRN}}$, $I_{\text{CHG}} = 150\text{mA}$, $R_{\text{SENSE}} = 10\text{m}\Omega$, Post-Calibration	135	150	165	mA
$I_{\text{CHG_ACC}}$ (2)	Charge current accuracy	$V_{\text{SRP}} - V_{\text{SRN}}$, $I_{\text{CHG}} = 800\text{mA}$, $R_{\text{SENSE}} = 10\text{m}\Omega$, Post-Calibration	720	800	880	mA
$I_{\text{TERM_RNG}}$ (1) (4)	Termination current regulation range	Firmware programmable range	1		400	mA
$I_{\text{TERM_ACC}}$ (2)	Termination current accuracy	$V_{\text{SRP}} - V_{\text{SRN}}$, $T_A = 25^\circ\text{C}$, $V_{\text{BAT_REG}} = 4.2\text{V}$, $I_{\text{TERM}} = 5\text{mA}$, $R_{\text{SENSE}} = 10\text{m}\Omega$, Post-Calibration	4.5	5	5.5	mA
Linear and MINSYS Modes						

Typical values stated where $T_A = 25^\circ\text{C}$ and $V_{BAT} = 3.8\text{V}$, MIN/MAX values stated where $T_A = -40^\circ\text{C}$ to 85°C and $V_{BAT} = 2.0\text{V}$ to 5.0V (unless otherwise noted)

PARAMETER		TEST CONDITIONS	MIN	TYP	MAX	UNIT
V_{LIN_RNG}	Linear mode operating voltage range	Linear mode starts (V_{LIN_START}) at $V_{BAT} = 2.4\text{V}$ with V_{BAT} rising after firmware-based exit from ZVCHG	2.05		5.0	V
$V_{MINSYS}^{(1)(4)}$	PACK voltage threshold when charge current is reduced	Firmware programmable range, 25mV steps	2750	3800	4500	mV
V_{MINSYS_ACC}	V_{MINSYS} accuracy	DC accuracy	-200		200	mV
Supplement Mode and Ideal Diode (ID) Modes						
V_{TH_ON}	Supplement Mode or ID_ON entry threshold	$V_{BAT} = 3.6\text{V}$, $V_{BAT} > V_{UVP}$, $V_{PACK}^{(5)} - V_{BAT}$, $R_{PACK} = 1\text{k}\Omega$	-25	-20	-15	mV
V_{TH_OFF}	Supplement mode exit threshold	$V_{BAT} = 3.6\text{V}$, $V_{BAT} > V_{UVP}$, $V_{PACK}^{(5)} - V_{BAT}$, $R_{PACK} = 1\text{k}\Omega$	-7.5	-5	-2.5	mV
	ID_OFF entry threshold	$V_{BAT} = 3.6\text{V}$, $V_{BAT} > V_{UVP}$, $V_{PACK}^{(5)} - V_{BAT}$, $R_{PACK} = 1\text{k}\Omega$	2.5	5	7.5	
$V_{TH_OFF_FINE}$	Supplement or ID charge current detection threshold	$V_{SRP} - V_{SRN}$		450		μV

- (1) Specified by Design. Not production tested.
- (2) Specified by Bench Evaluation. Not production tested.
- (3) Includes precharge (PCHG) and fast charge current settings
- (4) Specified typical value is the factory default setting. The setting in data flash can be changed in FULL ACCESS mode and is locked in SEALED mode. Refer to the BQ27Z855 Technical Reference Manual.
- (5) Including R_{PACK} error

5.20 CHG, DSG NFET Drivers

Typical values stated where $T_A = 25^\circ\text{C}$ and $V_{BAT} = 3.8\text{V}$, MIN/MAX values stated where $T_A = -40^\circ\text{C}$ to 85°C and $V_{BAT} = 2.0\text{V}$ to 5.0V (unless otherwise noted)

PARAMETER		TEST CONDITIONS	MIN	TYP	MAX	UNIT
V_{DSG_ON}	DSG FET driver ON output voltage	$C_{LOAD} = 10\text{nF}$, $V_{BAT} \geq 4\text{V}$	7.9	8.0	8.3	V
		$C_{LOAD} = 10\text{nF}$, $V_{BAT} < 4\text{V}$	$1.95 \times V_{BAT}$	$2 \times V_{BAT}$	$2.1 \times V_{BAT}$	
V_{CHG_ON}	CHG FET driver ON output voltage	$C_{LOAD} = 10\text{nF}$, $V_{BAT} \geq 4\text{V}$	7.9	8.0	8.3	V
		$C_{LOAD} = 10\text{nF}$, $V_{BAT} < 4\text{V}$	$1.95 \times V_{BAT}$	$2 \times V_{BAT}$	$2.1 \times V_{BAT}$	
V_{DSG_OFF}	DSG FET driver OFF output voltage	$C_{LOAD} = 10\text{nF}$, $V_{DSG_OFF} = V_{DSG} - V_{SS}$			0.1	V
V_{CHG_OFF}	CHG FET driver OFF output voltage	$C_{LOAD} = 10\text{nF}$, $V_{CHG_OFF} = V_{CHG} - V_{SS}$			0.1	V
$t_{DSG_RISE}^{(1)}$	DSG FET driver rise time	$C_{LOAD} = 10\text{nF}$, V_{DSG_ON} changes from 10% to 90% of V_{BAT} to $V_{DSG_ON(TYP)}$		400	800	μs
$t_{CHG_RISE}^{(1)}$	CHG FET driver rise time without CP capacitor	$C_{LOAD} = 10\text{nF}$, V_{CHG_ON} changes from 10% to 90% of V_{BAT} to $V_{CHG_ON(TYP)}$		400	800	μs
$t_{FET_FALL}^{(1)}$	DSG and CHG FET driver fall time	$C_{LOAD} = 10\text{nF}$, V_{FET} changes from $V_{FET_ON(TYP)}$ to V_{FET_OFF}		50	200	μs

- (1) Specified by Bench Evaluation. Not production tested.

5.21 Zero-volt Charging (ZVCHG)

Typical values stated where $T_A = 25^\circ\text{C}$ and $V_{BAT} = 3.8\text{V}$, MIN/MAX values stated where $T_A = -40^\circ\text{C}$ to 85°C and $V_{BAT} = 2.0\text{V}$ to 5.0V (unless otherwise noted)

PARAMETER		TEST CONDITIONS	MIN	TYP	MAX	UNIT
I_{ZVCHG}	Zero-volt charging current	$V_{PACK+} = 5\text{V}$, $V_{BAT} = 0\text{V}$, $R_{PACK} = 1\text{k}\Omega$			5	mA

5.22 General Purpose Input-Outputs (INT)

Typical values stated where $T_A = 25^\circ\text{C}$ and $V_{BAT} = 3.8\text{V}$, MIN/MAX values stated where $T_A = -40^\circ\text{C}$ to 85°C and $V_{BAT} = 2.0\text{V}$ to 5.0V (unless otherwise noted)

PARAMETER		TEST CONDITIONS	MIN	TYP	MAX	UNIT
V_{IH}	High-level input voltage	INT	$0.7 \times V_R$ EG18			V
V_{IL}	Low-level input voltage	INT			$0.3 \times V_{REG1}$ 8	V
V_{OH}	Output voltage high	INT, $I_{OH} = -450\mu\text{A}$	$0.85 \times V_{REG1}$ 8			V
V_{OL}	Output voltage low	INT, $I_{OL} = 1\text{mA}$			0.35	V
R_{PD}	Internal pull-down resistance	INT	80	100	120	k Ω
R_{PU}	Internal pull-up resistance	INT	80	100	120	k Ω
$C_{IN}^{(1)}$	Input capacitance	INT		1.5		pF
$I_{LKG}^{(1)}$	Input leakage current	INT		1		μA

(1) Specified by Design. Not production tested.

5.23 I²C Interface I/O (SDA, SCL)

Typical values stated where $T_A = 25^\circ\text{C}$ and $V_{BAT} = 3.8\text{V}$, MIN/MAX values stated where $T_A = -40^\circ\text{C}$ to 85°C and $V_{BAT} = 2.0\text{V}$ to 5.0V (unless otherwise noted)

PARAMETER		TEST CONDITIONS	MIN	TYP	MAX	UNIT
V_{DDIO}	External I/O supply voltage		1.1		3.6	V
V_{IH}	Input voltage high	SDA, SCL	$0.7 \times V_{DDIO}$			V
V_{IL}	Input voltage low	SDA, SCL			$0.3 \times V_{DDIO}$	V
V_{OL}	Output low voltage	SDA, SCL, $I_{OL} = -3\text{mA}$			0.4	V
$C_{IN}^{(1)}$	Input capacitance	SDA, SCL			10	pF
$I_{LKG}^{(1)}$	Input leakage current	SDA, SCL		0.5		μA

(1) Specified by Design. Not production tested.

5.24 I²C Interface Timing

Typical values stated where $T_A = 25^\circ\text{C}$ and $V_{BAT} = 3.8\text{V}$, MIN/MAX values stated where $T_A = -40^\circ\text{C}$ to 85°C and $V_{BAT} = 2.0\text{V}$ to 5.0V (unless otherwise noted)

PARAMETER		TEST CONDITIONS	MIN	NOM	MAX	UNIT
I²C 100kHz						
$f_{SCL}^{(1)}$	Clock frequency				100	kHz
$t_{HD:STA}^{(1)}$	START condition hold time		4			μs
$t_{LOW}^{(1)}$	Low period of SCL clock		4.7			μs
$t_{HIGH}^{(1)}$	High period of SCL clock		4			μs
$t_{SU:STA}^{(1)}$	Setup time for repeated START		4.7			μs
$t_{HD:DAT}^{(1)}$	Data in hold time		0			μs
$t_{SU:DAT}^{(1)}$	Data in setup time		250			ns
	Data out setup time		250			
$t_r^{(1)(2)}$	SDA and SCL rise time	30% to 70% of V_{DDIO}			1000	ns
$t_f^{(1)(2)}$	SDA and SCL fall time	30% to 70% of V_{DDIO}			300	ns
$t_{SU:STO}^{(1)}$	STOP condition setup time		4			μs

Typical values stated where $T_A = 25^\circ\text{C}$ and $V_{\text{BAT}} = 3.8\text{V}$, MIN/MAX values stated where $T_A = -40^\circ\text{C}$ to 85°C and $V_{\text{BAT}} = 2.0\text{V}$ to 5.0V (unless otherwise noted)

PARAMETER		TEST CONDITIONS	MIN	NOM	MAX	UNIT
$t_{\text{BUF}}^{(1)}$	Bus free time between STOP and START		4.7			μs
C_D	Capacitive load for each bus line				400	pF
I²C 400kHz						
$f_{\text{SCL}}^{(1)}$	Clock frequency				400	kHz
$t_{\text{HD:STA}}^{(1)}$	START condition hold time		0.6			μs
$t_{\text{LOW}}^{(1)}$	Low period of SCL clock		1.3			μs
$t_{\text{HIGH}}^{(1)}$	High period of SCL clock		0.6			μs
$t_{\text{SU:STA}}^{(1)}$	Setup time for repeated START		0.6			μs
$t_{\text{HD:DAT}}^{(1)}$	Data in hold time		0			μs
$t_{\text{SU:DAT}}^{(1)}$	Data in setup time		100			ns
	Data out setup time		100			
$t_r^{(1)(2)}$	SDA and SCL rise time	30% to 70% of V_{DDIO}	20		300	ns
$t_f^{(1)(2)}$	SDA and SCL fall time	30% to 70% of V_{DDIO}	$20 \times (V_{\text{DDIO}}/5.5)$		300	ns
$t_{\text{SU:STO}}^{(1)}$	STOP condition setup time		0.6			μs
$t_{\text{BUF}}^{(1)}$	Bus free time between STOP and START		1.3			μs
C_D	Capacitive load for each bus line				400	pF
I²C 1MHz						
$f_{\text{SCL}}^{(1)}$	Clock frequency				1000	kHz
$t_{\text{HD:STA}}^{(1)}$	START condition hold time		0.26			μs
$t_{\text{LOW}}^{(1)}$	Low period of SCL clock		0.5			μs
$t_{\text{HIGH}}^{(1)}$	High period of SCL clock		0.26			μs
$t_{\text{SU:STA}}^{(1)}$	Setup time for repeated START		0.26			μs
$t_{\text{HD:DAT}}^{(1)}$	Data in hold time		0			μs
$t_{\text{SU:DAT}}^{(1)}$	Data in setup time		50			ns
	Data out setup time		50			
$t_r^{(1)(2)}$	SDA and SCL rise time	30% to 70% of V_{DDIO}			120	ns
$t_f^{(1)(2)}$	SDA and SCL fall time	30% to 70% of V_{DDIO}	$20 \times (V_{\text{DDIO}}/5.5)$		120	ns
$t_{\text{SU:STO}}^{(1)}$	STOP condition setup time		0.26			μs
$t_{\text{BUF}}^{(1)}$	Bus free time between STOP and START		0.5			μs
C_D	Capacitive load for each bus line				100	pF

(1) Specified by Characterization. Not production tested.

(2) $V_{\text{DDIO}} = 1.2\text{V}$

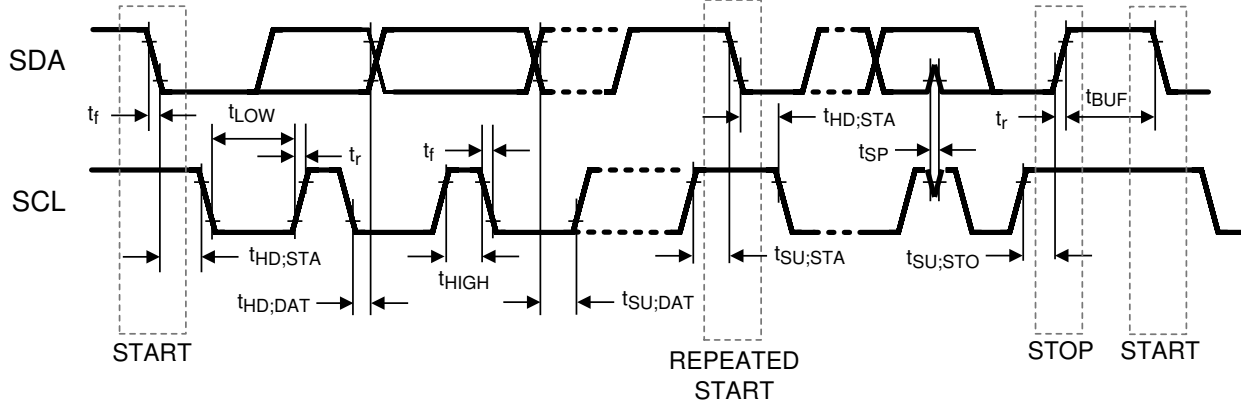

Figure 5-1. I²C Timing Diagram

ADVANCE INFORMATION

6 Detailed Description

6.1 Overview

The BQ27Z855 Single Cell Battery Fuel Gauge is a fully integrated battery management solution that employs integrated flash-based firmware, hardware- and firmware-based protections, and ECC ECDSA and SHA-2 authentication to provide a complete solution for single-cell battery architectures. The BQ27Z855 device also incorporates an integrated current limiter and ideal diode detector that can perform linear charging tasks such as constant current-constant voltage (CC-CV) charge profile control and dynamic power path management with MINSYS and battery supplement modes. The BQ27Z855 interfaces with a host system via an I²C interface and processes instructions and data using a state-of-the-art, ultra-low-power 32-bit RISC processor. High-performance, integrated analog peripherals allow support for a sense resistor down to 0.5mΩ and simultaneous current and voltage data conversion for instant power calculations. The following sections detail the overall block diagram and major component blocks included as part of the BQ27Z855 Single Cell Battery Fuel Gauge.

6.2 Functional Block Diagram

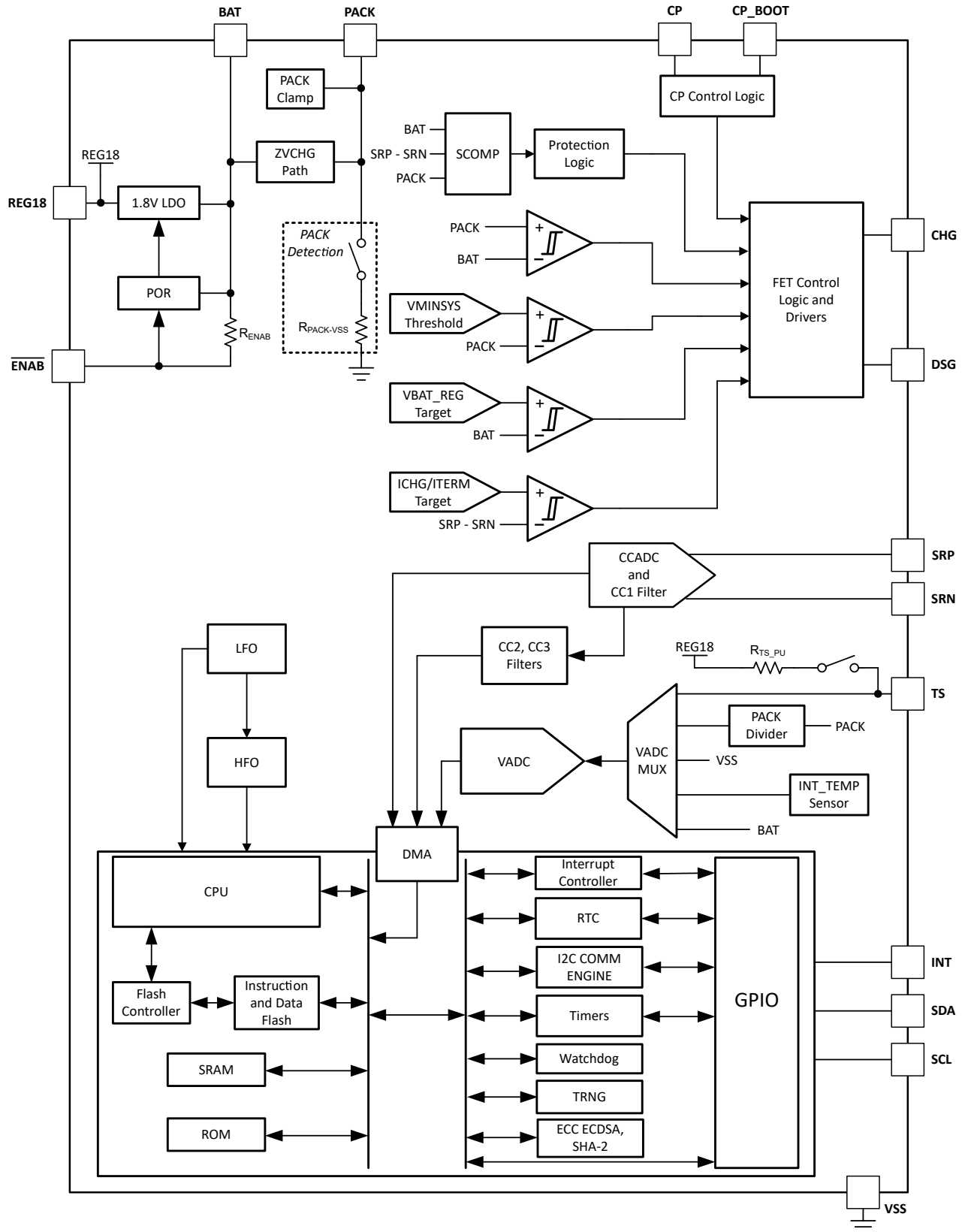

ADVANCE INFORMATION

6.3 Feature Description

6.3.1 BQ27Z855 Processor

The BQ27Z855 processor incorporates a 32-bit RISC Arm M0+ processor, a single-cycle 32-bit multiplier, 24-bit SysTick timer, and a nested vector interrupt controller (NVIC). All are all integrated in the processor.

6.3.2 Battery Parameter Measurements

The BQ27Z855 device measures cell voltage and current simultaneously using two independent ADCs and also measures temperature to calculate the information related to remaining capacity, full charge capacity, state-of-health, and other gauging parameters.

6.3.2.1 Analog-to-Digital Converter (VADC)

The first ADC is a 16-bit delta-sigma converter designed for general-purpose voltage measurements. The VADC automatically scales the input voltage range during sampling based on channel selection. The converter resolution is a function of its full-scale range and number of bits yielding a 38 μ V resolution.

6.3.2.2 VADC Multiplexer

The VADC multiplexer provides selectable connections to the device's external BAT, PACK, and TS pins as well as the internal temperature sensor (INT_TEMP). In addition, the multiplexer can independently enable the TS input connection to the internal biasing circuitry for an external thermistor and enables the user to short the multiplexer inputs for test and calibration purposes.

6.3.2.3 Coulomb Counter (CCADC) and Digital Filter (CC1)

The second ADC is an integrating analog-to-digital converter designed specifically for tracking charge and discharge activity, or Coulomb counting, of a rechargeable battery. It features a single-channel differential input that converts the voltage difference across a sense resistor between the SRP and SRN terminals with a resolution of 923nV. The differential input common mode voltage range is from V_{SS} to V_{BAT} and supports a 1-series cell high-side or low-side sensing option with a ± 100 mV input range.

The CC1 digital filter generates an 18-bit conversion value from the delta-sigma CCADC front-end. New conversions are available every 1s.

6.3.2.4 Internal Temperature Sensor (INT_TEMP)

An internal temperature sensor is available on the BQ27Z855 device to reduce the cost, power, and size of the external components necessary to measure temperature. It is measured by the VADC using the multiplexer and is ideal for quickly determining pack temperature under a variety of operating conditions.

The internal temperature sensor reports the measured temperature in terms of voltage and device firmware converts this voltage to temperature in units of $^{\circ}$ C to be reported for gauging and protection tasks. As an example, a difference in 0.05mV/ $^{\circ}$ C between the $V_{INT_TEMP(TYP)}$ value as stated in the [Internal Temperature Sensor \(INT_TEMP\) Specifications table](#) and the actual voltage drift value reported by the internal temperature sensor approximately equates to a temperature error of $\pm 1^{\circ}$ C.

6.3.2.5 External Temperature Sensor Support

The TS input is enabled with an internal 18k Ω (TYP) linearization pull-up resistor to support the use of a 10k Ω (25 $^{\circ}$ C) NTC external thermistor, such as the Semitec 103AT-2. The NTC thermistor should be connected between VSS and the individual TS pin. The analog measurement is then taken by the VADC through its input multiplexer.

If a different thermistor type is required, then changes to configurations in the device firmware may be required.

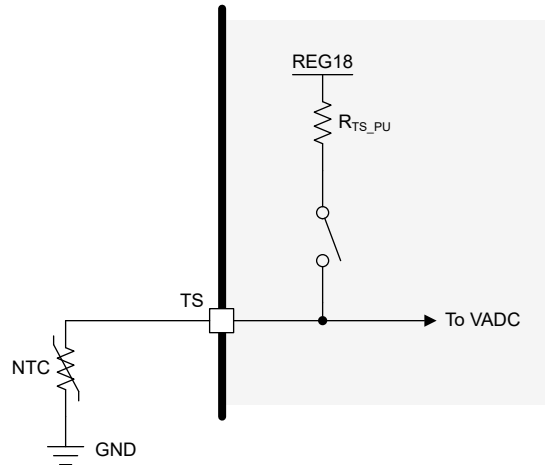

Figure 6-1. External Thermistor Biasing

6.3.3 Power Supply Control

The BQ27Z855 device uses the BAT pin as its power source. BAT powers the internal voltage sources and 1.8V LDO that supply references for the device.

6.3.4 $\overline{\text{ENAB}}$ Pin

The BQ27Z855 device can use the active low digital input $\overline{\text{ENAB}}$ pin to exit the device's SHELFB1, SHELFB2, and SHUTDOWN power modes. The digital input is connected to a weak internal pullup to BAT. A push-button can be connected to the $\overline{\text{ENAB}}$ pin to drive the pin to a low state for the device to exit SHELFB1, SHELFB2, or SHUTDOWN mode.

If the $\overline{\text{ENAB}}$ pin is connected directly to the device's GND reference (VSS), the BQ27Z855 device will not be able to enter SHELFB1, SHELFB2, or SHUTDOWN mode.

The $\overline{\text{ENAB}}$ pin can be left floating if using a push-button to exit SHELFB1, SHELFB2, or SHUTDOWN mode is not needed. The $\overline{\text{ENAB}}$ pin can also be left floating if the device needs the capability to enter SHELFB1, SHELFB2, or SHUTDOWN mode.

6.3.5 I²C Bus Communication Interface

The BQ27Z855 device has an I²C bus communication interface capable of supporting as low as 1.2V-level logic and up to a 1MHz I²C clock frequency.

6.3.6 Low Frequency Oscillator (LFO)

The BQ27Z855 device includes a low frequency oscillator (LFO) running at 65.536kHz.

6.3.7 High Frequency Oscillator (HFO)

The BQ27Z855 includes a high frequency oscillator (HFO) running at 16.384MHz.

The HFO is frequency locked to the LFO output.

6.3.8 Real Time Clock (RTC)

The BQ27Z855 includes a real time clock (RTC) that can provide the following information:

- Calendar
 - 4-digit year with automatic leap-year adjustment
 - Month
 - Day of the month
 - Day of the week
- Time of Day
 - Hours (24-hour format with optional daylight savings adjustment)

- Minutes
- Seconds

The RTC is sourced from the integrated LFO and can be enabled in all power modes except SHUTDOWN.

6.3.9 1.8V Low Dropout Regulator (REG18)

The BQ27Z855 device contains an integrated 1.8V LDO (REG18) that provides regulated supply voltage for the device CPU and internal digital logic.

This LDO requires a capacitor (C_{REG18}) with the recommended typical capacitance of 1.5 μ F connected between the device's REG18 and VSS pins. The capacitor must be placed as close as possible to the device.

6.3.10 FET Drivers (CHG, DSG)

The BQ27Z855 gas gauge includes two high-side NMOS FET drivers for charge (CHG) and discharge (DSG) control to disconnect the cell from the system and to control the flow of charge and discharge current. The device controls two external N-Channel MOSFETs in a back-to-back configuration for battery protection. The CHG and DSG FETs are automatically disabled if a protection fault is detected and can be re-enabled if the recovery conditions programmed in the device firmware are met.

6.3.10.1 Charge (CHG) FET Driver

The device's charge (CHG) FET driver allows for independent control of the CHG FET. The CHG FET is disabled automatically if a charge-related protection fault is detected, such as battery overvoltage (OVP) and overcurrent in charge (OCC). The CHG FET can be re-enabled if the recovery conditions programmed in the device firmware are met.

Additionally, the BQ27Z855 device's CHG FET can be enabled to be controlled in a linear operating mode to function as a current limiter and control the CC-CV charge profile of the battery. This also allows the CHG FET to be able to operate in an Ideal Diode mode where the CHG FET can be enabled to allow discharge current to flow through the CHG FET instead of the body diode and can be disabled if charge current is detected by the device's integrated ideal diode controller.

Refer to [Section 6.3.15](#) and [Section 6.3.16](#) for more information on the device's current limiter and ideal diode detector respectively.

6.3.10.2 Discharge (DSG) FET Driver

The device's discharge (DSG) FET driver allows for independent control of the DSG FET. The DSG FET is disabled automatically if a discharge-related protection fault is detected, such as battery undervoltage (UVP), overcurrent in discharge (OCD), and short circuit in discharge (SCD). The DSG FET can be re-enabled if the recovery conditions programmed in the device firmware are met.

6.3.11 Zero-volt Charging (ZVCHG)

ZVCHG (0-V charging) is a special function that allows charging a severely depleted battery. The BQ27Z855 device has ZVCHG enabled with no inhibit. This means a severely depleted battery with a voltage as low as 0V can be charged.

With a voltage applied at the PACK+ terminal of the battery pack, the BQ27Z855 device conducts ZVCHG current within the device via an internal path from the PACK pin to the BAT pin. The resistor between the PACK+ terminal of the battery pack and the PACK pin of the device current limits the ZVCHG current (I_{ZVCHG}) through the device effectively setting what ZVCHG current the battery charges at or is used to wake a secondary protector. I_{ZVCHG} is limited to $I_{ZVCHG(MAX)}$ as stated in the [Zero-volt Charging Specifications table](#).

If V_{BAT} is below the entry threshold set by device firmware to qualify the battery as being in a ZVCHG state, the BQ27Z855 device disables both the CHG and DSG FET and can start zero-volt charging once a voltage is applied at the PACK+ terminal of the battery pack. Once the battery is charged enough and V_{BAT} reaches the exit threshold programmed in device firmware, the device stops conducting zero-volt charging and assesses if the FETs can be turned ON.

Both the CHG and DSG FETs are disabled while the device is in a ZVCHG state.

The ZVCHG path through the device is enabled when V_{BAT} is below the device POR threshold ($V_{POR_TH} - V_{POR_HYS}$) or the device is in SHUTDOWN mode.

If the ZVCHG function is unused, a larger resistance value of R_{PACK} can be used.

CAUTION

Some battery providers do not recommend charging a depleted (self-discharged) battery. Consult the battery supplier to determine whether to have the ZVCHG battery charger function.

For safety purposes, the BQ27Z855 is specifically designed to be used in battery systems with at least 1 additional protector unit with an inhibited zero-volt charging feature. This prevents unwanted battery self-discharge to severely low voltage levels or initiating charging at very low battery voltages that can cause irreversible damage to the battery.

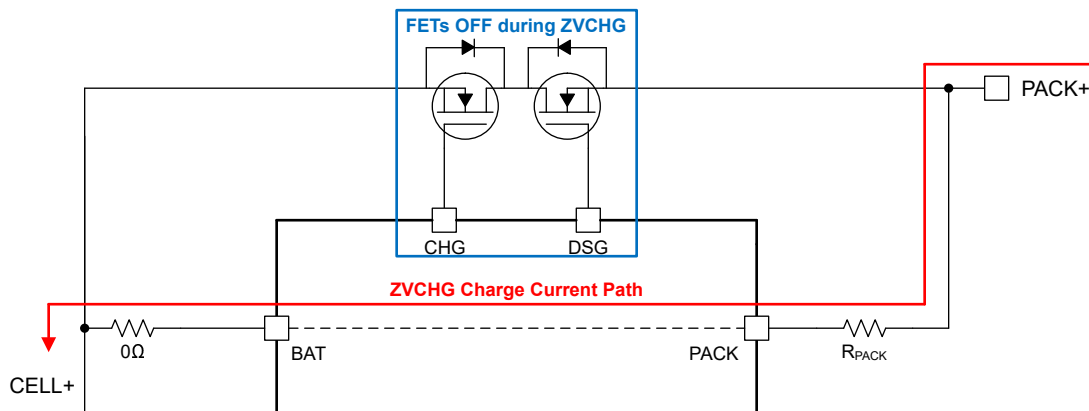

Figure 6-2. Zero-volt Charging Path

6.3.12 Integrated Protections

The BQ27Z855 gas gauge supports a wide range of hardware- and firmware-based protections for battery and system protection that can be easily configured using device firmware.

6.3.12.1 Hardware-based Protections

The BQ27Z855 device includes a module for hardware fault detection using a shared comparator (SCOMP) utilized for multiple voltage and current condition detections and can turn the CHG or DSG FET OFF if an abnormal voltage or current condition is detected. These detections include:

- Overvoltage Protection
- Undervoltage Protection
- Overcurrent in Charge Protection
- Overcurrent in Discharge Protection
- Short Circuit Current in Discharge Protection

6.3.12.1.1 Overvoltage Protection (OVP)

The overvoltage (OVP or HCOV) function detects abnormally high battery voltage. The OVP threshold and delay time are configurable through the device firmware. The detection circuit incorporates the delay setting before disabling the CHG FET. When an OVP event occurs, the **Safety Status** flag bit is set to 1 and is latched until it is cleared and the fault condition is removed.

6.3.12.1.2 Undervoltage Protection (UVP)

The undervoltage (UVP or HCUV) function detects abnormally low battery voltage. The UVP threshold and delay time are configurable through the device firmware. The detection circuit incorporates the delay setting before

disabling the DSG FET. When an UVP event occurs, the **Safety Status** flag bit is set to 1 and is latched until it is cleared and the fault condition is removed.

6.3.12.1.3 Overcurrent in Charge Protection (OCC)

The overcurrent in charge (OCC or HOCC) function detects abnormally high current in the charge direction. The OCC threshold and delay time are configurable through the device firmware. The detection circuit incorporates the delay setting before disabling the CHG FET. When an OCC event occurs, the **Safety Status** flag bit is set to 1 and is latched until it is cleared and the fault condition is removed.

6.3.12.1.4 Overcurrent in Discharge Protection (OCD)

The overcurrent in discharge (OCD or HOCD) function detects abnormally high current in the discharge direction. The OCD threshold and delay time are configurable through the device firmware. The detection circuit incorporates the delay setting before disabling the DSG FET. When an OCD event occurs, the **Safety Status** flag is set to 1 and is latched until it is cleared and the fault condition his removed.

6.3.12.1.5 Short Circuit Current in Discharge Protection (SCD)

The short circuit current in discharge (SCD or HSCD) function detects catastrophic current conditions in the discharge direction. The SCD thresholds and delay times are configurable through the device firmware. The detection circuit incorporates the delay setting before disabling the DSG FET. When an SCD event occurs, the **Safety Status** flag bit is set to 1 and is latched until it is cleared and the fault condition is removed.

6.3.12.1.6 Wake-up Comparator (I-WAKE)

The BQ27Z855 device has the ability to wake from SLEEP and DEEP SLEEP mode if substantial charge or discharge current is detected flowing across the external sense resistor. The device has two independent current wake thresholds for detecting charge current (WAKE_CC) and discharge current (WAKE_CD) that are configurable through device firmware.

6.3.12.2 Firmware-based Protections

In addition to hardware-based protections, the BQ27Z855 device includes a large suite of firmware-based protections to detect multiple voltage and current conditions and turn the CHG or DSG FET OFF if an abnormal voltage or current condition is detected. These firmware-based protections are divided into primary and secondary level protections.

6.3.12.2.1 Primary Level Protection Features

Primary level protections are protection features that can disable the CHG or DSG FET when an abnormal voltage or current condition is detected and the device can recover from to turn the appropriate FET back ON when the abnormal condition is removed.

The BQ27Z855 gas gauge supports the following primary level protection features for battery and system protection, which can be configured using device firmware:

- Cell Undervoltage Protection (CUV)
- Cell Overvoltage Protection (COV)
- Overcurrent in CHARGE (OCC)
- Overcurrent in DISCHARGE (OCD)
- Overtemperature in CHARGE (OTC)
- Overtemperature in DISCHARGE (OTD)
- Undertemperature in CHARGE (UTC)
- Undertemperature in DISCHARGE (UTD)
- Precharge Timeout (PTO)
- Fast Charge Timeout (CTO)

6.3.12.2.2 Secondary Level Protection Features

Secondary level protections are protection features that can be used to indicate more serious faults and permanently disable the use of the battery pack.

The BQ27Z855 gas gauge supports the following secondary level protection features for battery and system protection, which can be configured using device firmware:

- Safety Cell Undervoltage (SUV)
- Safety Cell Overvoltage (SOV)
- CHG FET Failure (CFETF)
- DSG FET Failure (DFETF)

6.3.13 Gas Gauging

The BQ27Z855 uses the Dynamic Z-Track™ algorithm to measure and calculate the available capacity in battery cells. The BQ27Z855 accumulates a measure of charge and discharge currents and compensates the charge current measurement for the temperature, state-of-charge, and relaxation time constants of the battery. The BQ27Z855 estimates self-discharge of the battery and also adjusts the self-discharge estimation based on temperature.

For more information on the theory and implementation of the Dynamic Z-Track™ algorithm, refer to the following Application Note on Dynamic Z-Track™: [Dynamic Z-Track™ Technology: An Advanced Battery Gauging Algorithm for Dynamic Load Applications](#).

6.3.14 Advanced Battery Algorithms

In addition to gas gauging via the Dynamic Z-Track™ algorithm, the BQ27Z855 device includes a suite of advanced battery algorithms to support Li-ion cell chemistries with Si-anodes and to provide an extra layer of battery monitoring and additional information to the system host device.

For more details on each individual algorithm, refer to their respective sections in the BQ27Z855 Technical Reference Manual.

6.3.14.1 Si-anode Chemistry Support

Li-ion batteries with silicon-based anodes offer unique advantages compared to Li-ion batteries with graphite-based anodes. The primary advantage is Li-ion cells with Si-anodes tend to have a higher energy density than Li-ion cells with graphite anodes. However, the silicon degrades faster than graphite in the anode of Li-ion cells causing the Si-anode cell's open circuit voltage (OCV) curve to shift over time with cell aging. This OCV curve shift is especially prevalent in batteries containing a small amount of silicon (up to 20%).

Through device firmware, the BQ27Z855 device enables support for gauging Si-anode cells accurately on both small and dominant silicon type batteries by tracking the OCV curve shift using the predictive modeling of the Dynamic Z-Track™ technology.

6.3.14.2 Internal Short Indication (ISI)

Li-ion cells typically have a very low level of self-discharge or leakage current indicating the cell is healthy. However, abnormally high leakage current, usually due to a build-up of copper dendrites in Li-ion cells, can indicate serious safety concerns with the cell.

The BQ27Z855 device can be enabled via firmware to determine if a battery has an internal short via measuring the leakage current of the battery cell and alert the system host if the leakage current exceeds a programmed threshold for the host to intervene and take any appropriate action.

6.3.14.3 Battery Swelling Detection (BSD)

Over the lifetime use of a Li-ion cell, particularly pouch cells, a battery can grow or inflate typically due to gas buildup in the cell during use. This battery swelling is correlated to the change in battery impedance.

The BQ27Z855 can be enabled via firmware to track the impedance of the battery and alert the system host if the tracked change in battery impedance indicates potential battery swelling. The host can then intervene and take any appropriate action.

6.3.15 Integrated Current Limiter and Charge Control Features

The BQ27Z855 device supports charge control features using the device's integrated current limiter or when using a smart charger with the BQ27Z855 device in a system.

The device can be configured via firmware to charge a battery or interact with a smart charger in a system. In both configurations, the charging current and charging voltage for the device's integrated current limiter or a smart charger to regulate at are programmable within data flash.

6.3.15.1 Integrated Current Limiter

The BQ27Z855 has an integrated current limiter feature to control the CHG FET in a linear operating mode to function as a linear charger. This linear charger function allows the BQ27Z855 device to directly and autonomously control battery charging with a large suite of firmware programmable settings and controls.

These battery charging features and controls include:

- Regulates charging current and charging voltage based on programmable charge profile thresholds and settings in device data flash
- Supports charging a battery using a step-charging profile with up to 5 programmable constant current and constant voltage steps
- Adjusts charging voltage and charging current for a constant current – constant voltage (CC–CV) charging profile based on the active temperature range—JEITA temperature ranges T1, T2, T3, T4, T5, and T6
- Provides more complex charging profiles, including sub-ranges within a standard temperature range
- Provides precharging and zero-volt charging
- Supports dynamic power path management with MINSYS and battery supplement modes
- Disables charge when certain safety conditions such as hardware- or firmware-based protections are detected
- Employs charge inhibit and charge suspend if battery temperature is out of programmed range
- Activates charge and discharge alarms to report charging faults and to indicate charge status
- Reports the charging current and charging voltage to a system-side host using the I²C bus communication interface
- Reduces charging current and charging voltage to account for cell aging

6.3.15.1.1 CHG FET State Machine

The BQ27Z855 CHG FET output is controlled by CHG FET FSM logic, which can be manipulated by device firmware and several system parameters.

There are 4 distinct modes device firmware transitions between depending on programmable settings in device data flash and system parameters: OFF, ON, Linear, and Ideal Diode. Depending on the current mode the device is operating in, the device can operate in a particular state and make hardware-based transitions between states within modes.

Device firmware determines the mode the device operates in while device digital hardware determines the state within a mode the device operates in.

The CHG FET FSM logic is detailed in [Figure 6-3](#).

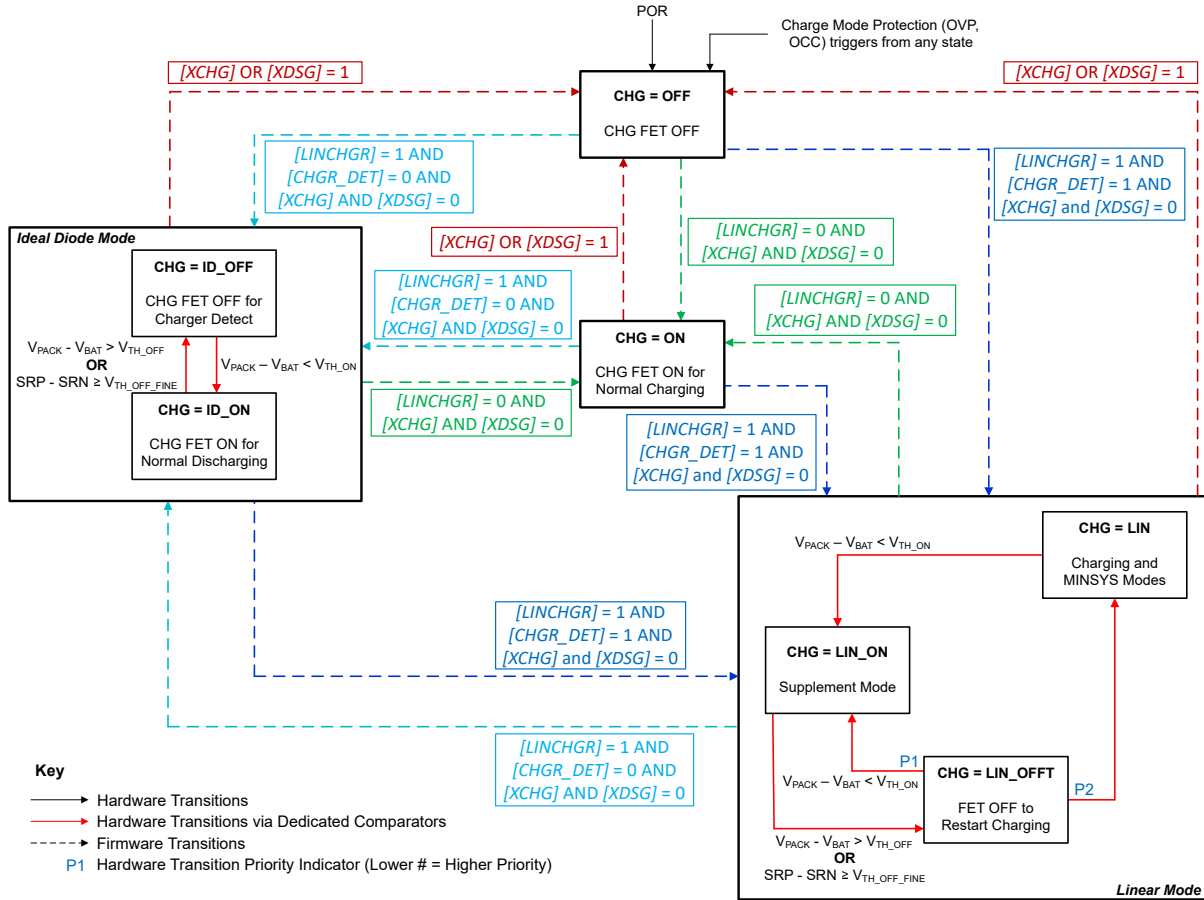

Figure 6-3. CHG FET State Diagram

The CHG FET FSM logic controls the state of the CHG FET with the following key considerations:

1. Firmware transitions override hardware transitions and takes highest priority after hardware-based protection circuits
2. Available hardware transitions in Linear and Ideal Diode modes check several system parameters to ensure proper device and system operation:
 - a. A dedicated voltage comparator (DCOMP) between the PACK and BAT pin voltages detects when $V_{PACK} - V_{BAT} < V_{TH_ON}$ to turn the CHG FET ON and $V_{PACK} - V_{BAT} > V_{TH_OFF}$ to turn the CHG FET OFF
 - b. A Coulomb counter-based charge current measurement digital filter (CC3) detects when $V_{SRP} - V_{SRN} \geq V_{TH_OFF_FINE}$ to turn the CHG FET OFF
3. State exit transition priorities are indicated as P1, P2, and so on where P1 is the highest priority transition
4. The HFO is automatically enabled when the device is in all states except OFF, ON, and ID_ON to reduce device power consumption.

Table 6-1. CHG FET FSM Modes and States

Modes	States	Charger Function
OFF	OFF	ZVCHG, Charging Disabled
ON	ON	Normal Charging or Discharging
Linear	LIN	PCHG, CC, CV, MINSYS
	LIN_ON	Supplement
	LIN_OFFT	

Table 6-1. CHG FET FSM Modes and States (continued)

Modes	States	Charger Function
Ideal Diode	ID_OFF	Charger Detect, VCT
	ID_ON	Normal Discharging, Charger Removed

6.3.15.1.2 Linear Mode

During Linear mode, the BQ27Z855 device controls the external CHG FET in a linear operating mode to regulate charging current, charging voltage, and the CHG FET state.

There are several control loops that influence the charge current and charge voltage:

- Constant Current loop (CC)
- Constant Voltage loop (CV)
- MINSYS loop
- Battery supplement loop

During battery charging, all control loops are enabled and the dominant loop takes control over the other loops.

The device supports several different battery chemistries and system requirements for single-cell applications through programmable battery charge profile parameters such as charge voltage regulation (V_{BAT_REG}), charge current regulation (I_{CHG}), and PACK voltage threshold to reduce charge current (V_{MINSYS}) in device firmware. Refer to the BQ27Z855 Technical Reference Manual for a list of all programmable battery charge profile parameters in device data flash.

6.3.15.1.2.1 Battery Charging Process

When the device detects a valid input voltage source is connected to the PACK+ terminal of the battery pack and the device's integrated current limiter function is enabled, the state of the $[CHGR_DET]$ bit determines if battery charging is initiated. If the $[CHGR_DET]$ bit goes high and battery charging can be initiated, the device transitions to Linear mode. During battery charging, the CHG FET is in the CHG = LIN state within Linear mode.

Battery charging is disabled via turning the CHG FET OFF. The CHG FET can turn OFF and transition to the CHG = ID_OFF state if the $[XCHG]$ bit is set, such as when a hardware- or firmware-based charge mode protection like OVP or OCC trips, or the $[LINCHGR]$ bit is cleared. If the device's current limiter is disabled, the CHG FET will instead transition to the CHG = OFF state.

Figure 6-4 illustrates a typical CC-CV battery charge profile.

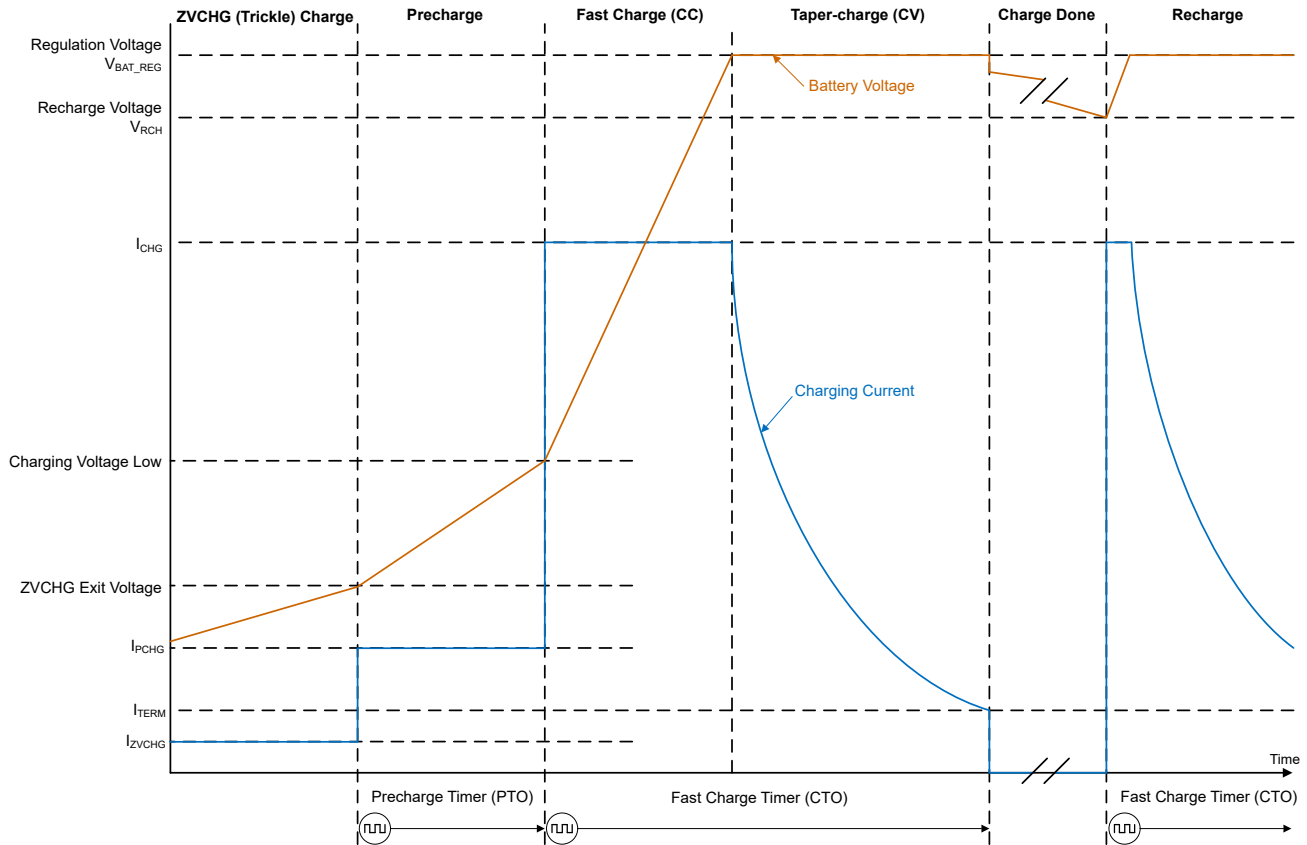

Figure 6-4. Typical CC-CV Battery Charge Profile

Figure 6-5 illustrates a CC-CV battery charge cycle the BQ27Z855 device steps through and tracks via a state machine regardless of the state of the `[CHGR_DET]` bit. The device controls what charge profile state the battery is currently operating in in parallel to controlling what state the CHG FET is in via the CHG FET FSM.

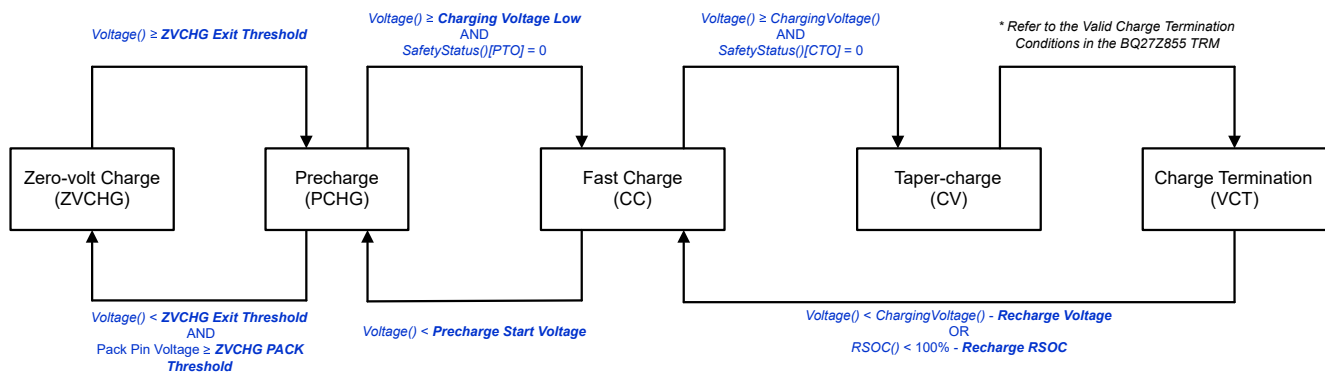

Figure 6-5. Linear Charge Profile State Machine

6.3.15.1.2.2 Zero-volt Charge (ZVCHG)

The BQ27Z855 device supports charging severely depleted batteries using a zero-volt charge (ZVCHG) or trickle charge feature. In order to prevent damage to the battery, the device will charge the battery at a very low current level (I_{ZVCHG}) when the battery is below the programmable **ZVCHG Exit Threshold** data flash parameter and a valid input voltage source at PACK+ is present.

During ZVCHG mode, the device disables both the CHG and DSG FETs, so the CHG FET is in the CHG = OFF state.

For a more detailed description on the BQ27Z855 device's ZVCHG feature, refer to [Section 6.3.11](#).

6.3.15.1.2.3 Precharge (PCHG)

When the battery voltage rises to or above the programmed **ZVCHG Exit Threshold** value, the device transitions to Linear mode with the CHG FET now in the CHG = LIN state to operate in Precharge mode. In Precharge mode, the device charges the battery via the Constant Current (CC) loop at the charge current regulation level I_{CHG} . The device regulates I_{CHG} according to the programmed **Pre-Charging:Current** value in device data flash. Once the battery reaches the programmed **Charging Voltage Low** value, the device will then operate in Fast Charge mode and charge the battery according to the programmed I_{CHG} value.

If enabled, the Precharge Timeout Protection (PTO) safety timer counts the time the device spends in Precharge mode and can disable charging if the accumulated time exceeds the **PTO:Delay** threshold.

6.3.15.1.2.4 Fast Charge (CC)

The BQ27Z855 device has two main loops to control battery charging when the battery voltage reaches the programmed **Charging Voltage Low** value: the Constant Current (CC) and Constant Voltage (CV) loops.

When the device is in Fast Charge (CC) mode, the CC loop is dominant and the battery is charged at the charge current regulation level I_{CHG} based on the temperature range and battery voltage range the device is presently operating in. The different I_{CHG} settings the CC loop can regulate charging current at is configurable within device data flash (Refer to the Charging Current section of the BQ27Z855 Technical Reference Manual). The CC loop regulates charging current at the appropriate I_{CHG} setting unless charging is disabled due to a hardware- or firmware-based protection tripping (including JEITA temperature-related protections) or the MINSYS loop is active.

If enabled, the Fast Charge Timeout Protection (CTO) safety timer counts the time the device spends in Fast Charge and Taper-charge modes and can disable charging if the accumulated time exceeds the **CTO:Delay** threshold.

6.3.15.1.2.5 Taper-charge (CV)

Once the battery voltage reaches the charge voltage regulation target (V_{BAT_REG}), the device operates in Taper-charge mode. The CV loop becomes dominant and the charging current begins to naturally taper off. The different V_{BAT_REG} settings the CV loop can regulate charging voltage at based on the present temperature range is configurable within device data flash (Refer to the Charging Voltage section of the BQ27Z855 Technical Reference Manual). Once the charging current reaches the termination current target (I_{TERM}) programmed by the **Charge Term Taper Current** data flash parameter and all Valid Charge Termination conditions stated in the BQ27Z855 Technical Reference Manual are met, battery charging is done and the device sets the **[VCT]** bit.

6.3.15.1.2.6 Charge Termination (VCT)

The device will automatically terminate charging once the charge current reaches the programmable I_{TERM} value and all Valid Charge Termination conditions stated in the BQ27Z855 Technical Reference Manual are met. After termination, the device operates in Charge Termination mode and disables the CHG FET to disconnect the battery to the system load. The device disables the CHG FET by transitioning the CHG FET to Ideal Diode mode to set CHG = ID_OFF. Power is still provided to the system load as long as the input voltage source is connected.

Termination is only enabled when the CV loop is active and dominant during taper-charge operation. Termination is disabled if the charge current reaches I_{TERM} while the MINSYS loop or battery supplement is active. The device's current limiter will only terminate charging when the current drops to I_{TERM} due to the battery reaching the target CV voltage and not due to charge current limitations imposed by the previously mentioned control loops.

After termination, the CHG FET is disabled and the battery voltage is monitored to check if it has dropped to the programmable Recharge Voltage (V_{RCH}) threshold. If it does, a new charge cycle is established. The safety timers are reset. During charging or even when termination is reached, the device will still support the higher system loads using battery supplement mode.

6.3.15.1.2.7 Step-charging Profile Support

In addition to a CC-CV battery charging profile, the BQ27Z855 supports a step-charging battery charge profile with up to 5 configurable CC-CV steps using device firmware. The device uses the same control loops as during a CC-CV battery charging profile.

Figure 6-6 illustrates an example step-charging battery charge profile with 5 CC-CV steps.

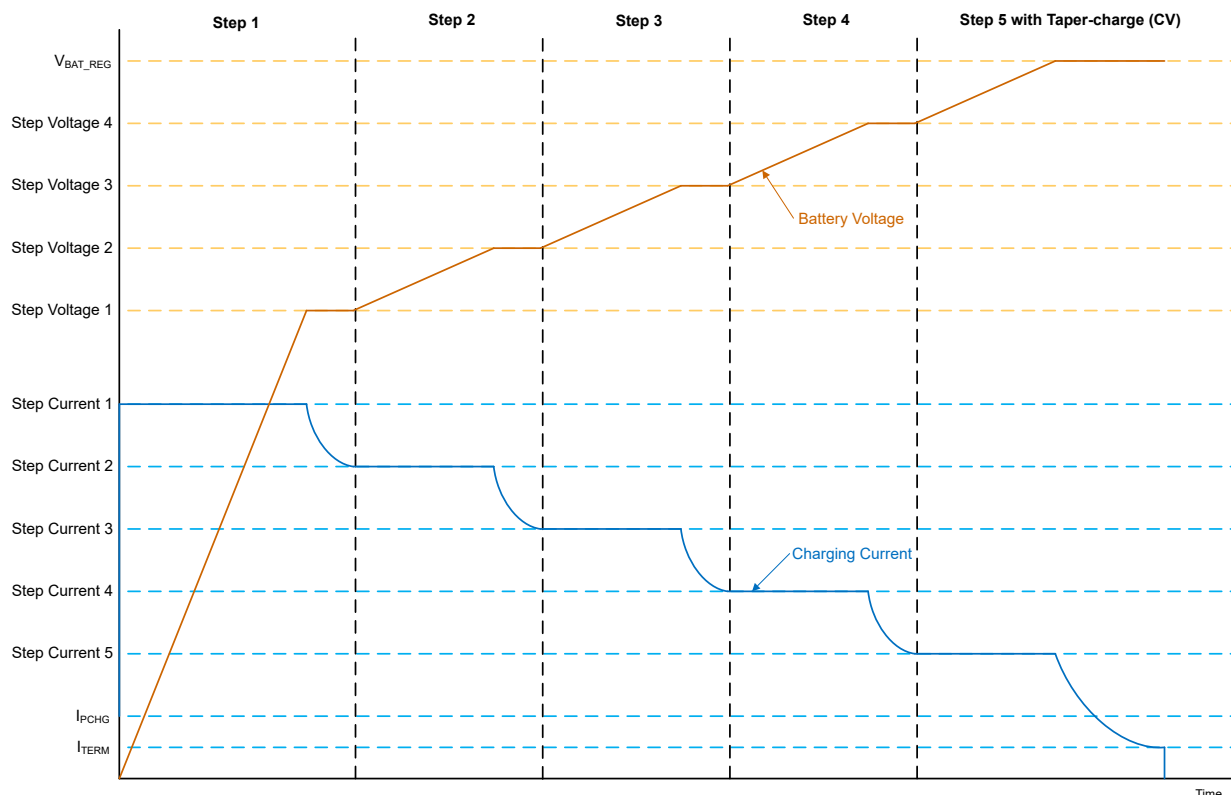

Figure 6-6. Example Step-charging Battery Charge Profile with 5 CC-CV Steps

Device firmware also includes a configurable option to disable the CV regulation portions within individual CC-CV steps. If the CV regulation portions are disabled, the device conducts step-charging with only CC steps.

Figure 6-7 illustrates an example step-charging battery charge profile with 5 CC steps.

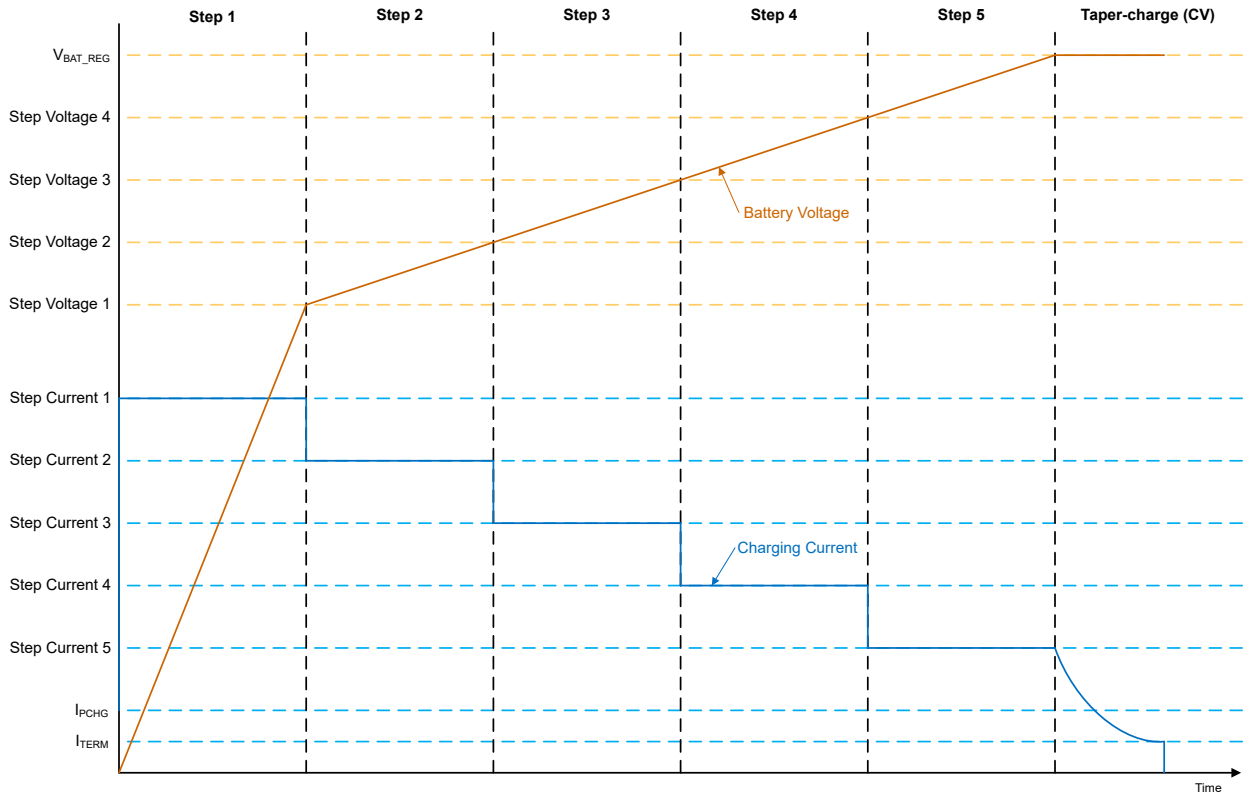

Figure 6-7. Example Step-charging Battery Charge Profile with 5 CC Steps

Figure 6-8 illustrates an N-step step-charging battery charge cycle the BQ27Z855 device steps through and tracks via a state machine regardless of the state of the $[CHGR_DET]$ bit. The device controls what charge profile state and CC-CV or CC step the battery is currently operating at in parallel to controlling what state the CHG FET is in via the CHG FET FSM.

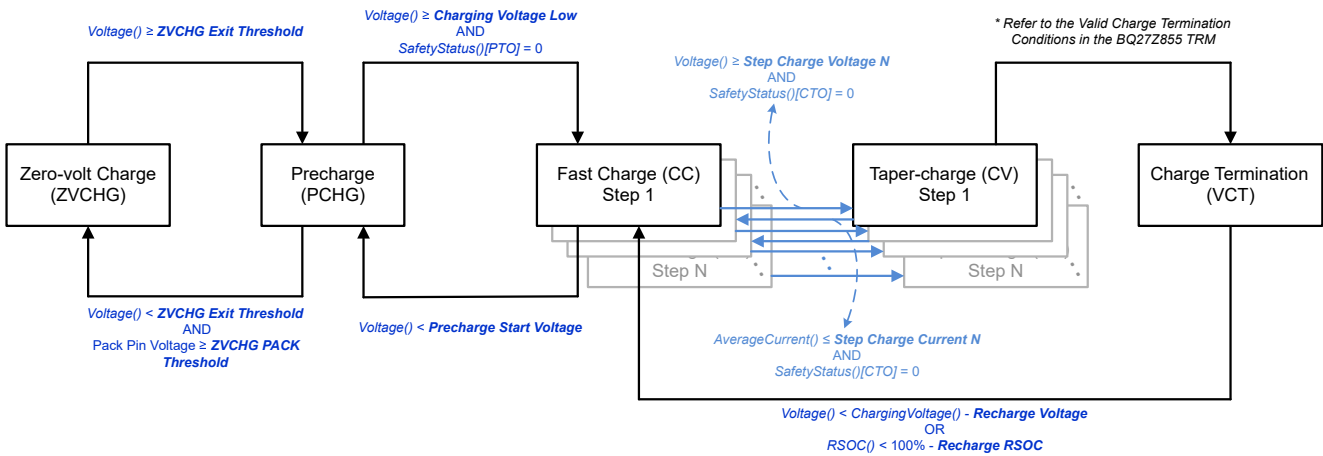

Figure 6-8. Step-charging Charge Profile State Machine

6.3.15.1.3 MINSYS Mode

When the device is in Linear Mode in the CHG = LIN state, the MINSYS regulation loop can be active. With a valid input power source connected at the PACK+ node of the system, the current into the PACK+ node is shared between charging the battery and powering the system load. If the sum of the battery charging current and load current exceeds the output current limit of the input power source, the MINSYS loop activates to reduce battery charging current and prioritize the system load.

During MINSYS mode, the device will increase or decrease the CHG FET gate drive voltage to reduce charging current and maintain the PACK voltage at or above V_{MINSYS} . The V_{MINSYS} threshold setting is programmable using device firmware.

PACK voltage is maintained above battery voltage when the MINSYS loop is active. If PACK voltage falls below the supplement mode threshold (V_{TH_ON}), the device will enter supplement mode (CHG = LIN_ON).

Battery termination is disabled when the MINSYS loop is active.

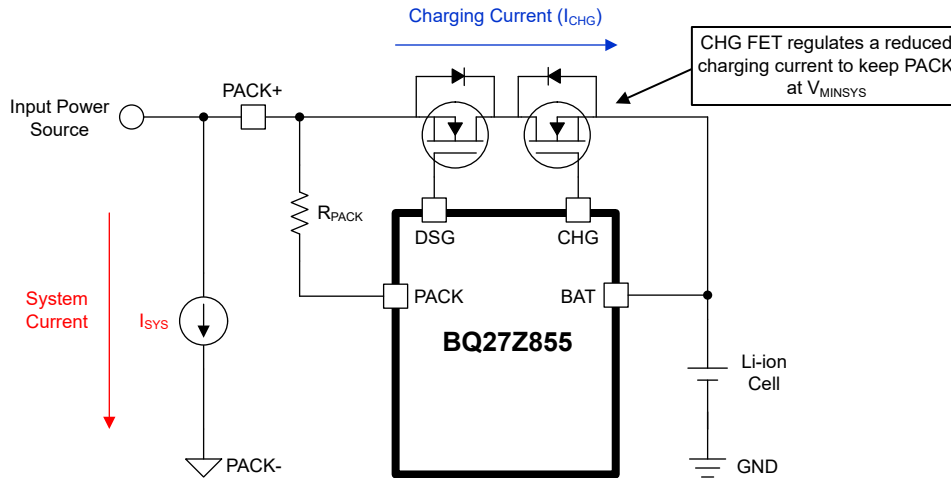

Figure 6-9. MINSYS Mode Operation

6.3.15.1.4 Battery Supplement Mode

While in MINSYS mode (CHG = LIN), if the charging current falls to zero and the system load current increases beyond the output current limit of the input power source connected at PACK+, the voltage at PACK reduces further. When the PACK voltage drops below the battery voltage to V_{TH_ON} , the battery supplements the system load and the device enters the CHG = LIN_ON state. The battery stops supplementing the system load when either the voltage on the PACK pin rises within the battery voltage to V_{TH_OFF} or sufficient positive or charging current flows through the sense resistor to produce a differential voltage that reaches or exceeds $V_{TH_OFF_FINE}$. The device then transitions to the CHG = LIN_OFFFT state.

If the voltage at PACK falls below the battery voltage to V_{TH_ON} while in the CHG = LIN_OFFFT state, the device enters the CHG = LIN_ON state. If the voltage at PACK stays above the V_{TH_OFF} threshold while in the CHG = LIN_OFFFT state, the device will return to the CHG = LIN state to resume linear charging. Entry into CHG = LIN_ON from CHG = LIN_OFFFT is always prioritized over entry to CHG = LIN to support the current load needed by the system.

The device uses the following hardware-based modules to transition in and out of supplement mode based on several system parameters:

- A dedicated voltage comparator (DCOMP) between the device's BAT and PACK pins to assess if the differential voltage between the BAT and PACK reaches the V_{TH_ON} and V_{TH_OFF} thresholds
- A Coulomb counter-based charge current measurement digital filter (CC3) to assess if the current flowing across the sense resistor produces a differential voltage that reaches or exceeds the $V_{TH_OFF_FINE}$ threshold

To support supplement mode and consecutive high system load pulses, the device turns the CHG FET ON using an external capacitor (C_{CP}) connected between the device's CP and CP_BOOT pins. This capacitor is discharged to the device's CHG pin when the device enters the CHG = LIN_ON state and is recharged immediately after the CHG FET turns ON. Additionally if the device's current limiter is enabled, the external CP capacitor is charged during device operation regardless of whether the device is actively charging a battery.

During supplement mode, the battery supplement current is not regulated. However, the device's hardware-based and firmware-based OCD and SCD protections are active if enabled.

Battery termination is disabled while the device is in supplement mode.

Battery voltage must be higher than the hardware-based undervoltage protection (V_{UVP}) in order for the device to support supplement mode.

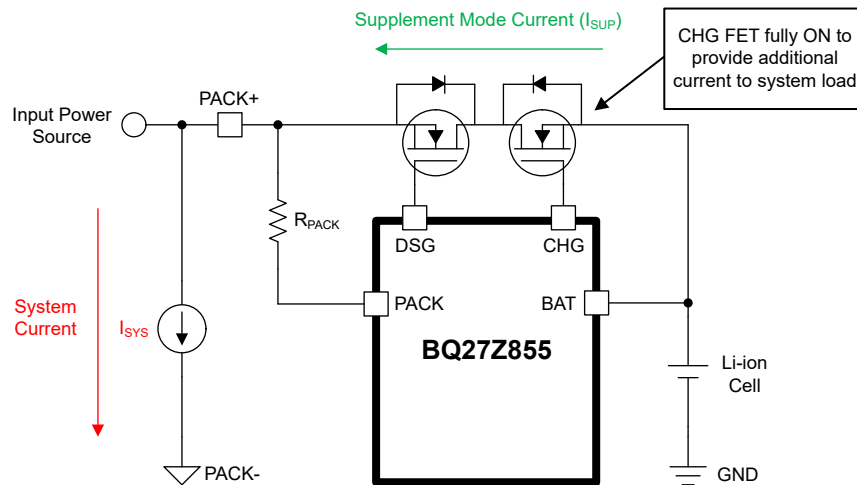

Figure 6-10. Supplement Mode Operation

6.3.15.2 Interaction with a Smart Charger

When the BQ27Z855 device's integrated current limiter is not enabled, the device can interact with a smart charger in a system to support charge control features.

These charge control features include:

- Reports charging voltage and charging current based on the active temperature range—JEITA temperature ranges T1, T2, T3, T4, T5, and T6
- Provides more complex charging profiles, including sub-ranges within a standard temperature range
- Reports the appropriate charging current and charging voltage needed for constant current – constant voltage (CC–CV) charging profile to the smart charger using the I²C bus communication interface
- Provides pre-charging and zero-volt charging
- Employs charge inhibit and charge suspend if battery pack temperature is out of programmed range
- Activates charge and discharge alarms to report charging faults and to indicate charge status
- Request reduced charging current and charging voltage from the smart charger to account for cell aging

Refer to the Advanced Charge Algorithm chapter of the BQ27Z855 Technical Reference Manual for more information on the device's suite of charge control features.

6.3.16 Ideal Diode Mode

The BQ27Z855 device can control the CHG FET to function as an ideal diode to block charging current when the device detects a valid input voltage source is present.

When the device is in Ideal Diode mode during battery discharging, the device enters the CHG = ID_ON state and the CHG FET is enabled to allow discharge current to flow through the FET instead of the CHG FET's body diode. However when the device is in the CHG = ID_ON state and PACK voltage exceeds the battery voltage or charging current is detected, then the CHG FET transitions to the CHG = ID_OFF state to turn the FET OFF.

The device uses the following hardware-based modules to control the FET state within Ideal Diode mode based on several system parameters:

- A dedicated voltage comparator (DCOMP) between the device's BAT and PACK pins to assess if the differential voltage between the BAT and PACK reaches the V_{TH_ON} and V_{TH_OFF} thresholds
- A Coulomb counter-based charge current measurement digital filter (CC3) to assess if the current flowing across the sense resistor produces a differential voltage that reaches or exceeds the $V_{TH_OFF_FINE}$ threshold

Additionally, the device is in Ideal Diode mode after battery charging termination. After termination, the device operates in Charge Termination mode and disables the CHG FET to disconnect the battery from the system load. The device disables the CHG FET by transitioning the CHG FET to Ideal Diode mode to set CHG = ID_OFF. Power is still provided to the system load as long as the input voltage source is connected. The device will still support any high system loads that may occur with the input voltage source still connected using battery supplement mode via transitioning the CHG FET to the CHG = ID_ON state.

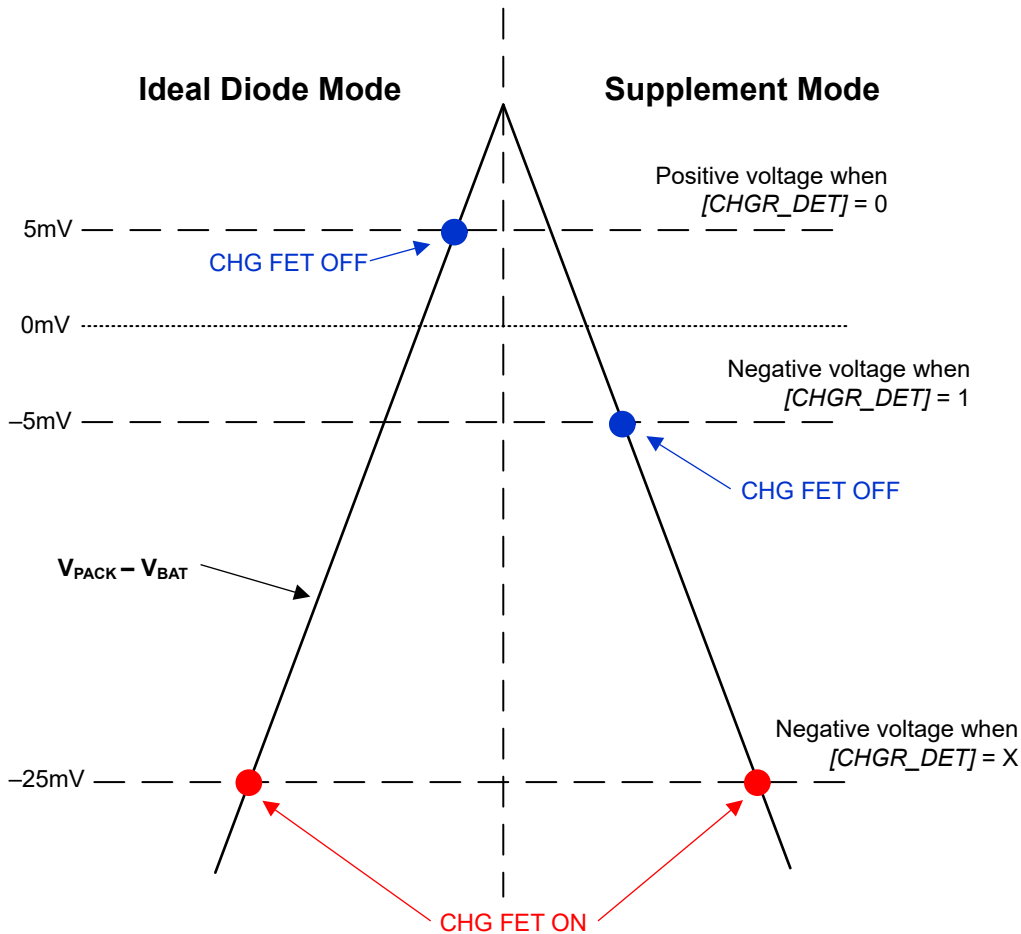

Figure 6-11. DCOMP-based Detection Thresholds in Ideal Diode and Supplement Modes

6.3.17 Lifetime Data Logging Features

The device supports data logging of several key parameters for warranty and analysis:

- Maximum and Minimum Cell Voltages
- Maximum Charge Current
- Maximum Discharge Current
- Maximum Average Discharge Current
- Maximum Average Discharge Power
- Maximum and Minimum Cell Temperature
- Maximum and Minimum Internal Temperature Sensor Temperature
- Number of Safety Events Occurrences and the Last Cycle of the Occurrence
- Number of Valid Charge Termination and the Last Cycle of the Valid Charge Termination
- Number of Qmax and Ra Updates and the Last Cycle of the Qmax and Ra Updates
- Number of Shutdown Events
- Total FW Runtime and Time Spent in Each Temperature Range (This data is updated every 2 hours if a difference is detected.)

Refer to the Lifetime Data Collection chapter of the BQ27Z855 Technical Reference Manual for more information on the device's lifetime data logging features.

6.3.18 Authentication

The BQ27Z855 device supports authentication by the host using Elliptic Curve Cryptography (ECC) or SHA-256.

6.3.18.1 ECC ECDSA Authentication

The BQ27Z855 device supports authentication by the host using ECC, which uses a 256-bit key system for the authentication process. The BQ27Z855 device employs the ECDSA variant of ECC authentication. Additionally, the ECC private key is required to be stored only in the battery pack, which makes ECC-based key management more simple and secure. The signing time would be less than 200ms and the overall hardware and firmware architecture to support this response time enables an additional level of protection.

For additional information on ECC authentication on the TI gas gauges, refer to the following Application Note: [Implementation of Elliptic Curve Cryptography Authentication on TI Battery Fuel Gauges](#).

6.3.18.2 SHA-256 Authentication

The device supports authentication by the host using SHA-256.

The gas gauge can be configured to require SHA-256 authentication before the device can be unsealed or allow full access.

6.3.19 Over the Air (OTA) Field Updater

The BQ27Z855 device incorporates the ability to update device firmware remotely in the field using over the air (OTA) updates. These OTA updates to device firmware can be made to update device firmware version, upgrade firmware-based features and algorithms, and modify ChemID parameters.

All [hardware-based protections](#) are still enabled while OTA updates occur. It is not recommended to change the threshold and delay settings of the hardware-based protections when the device is operating in the field.

Device firmware is updated in small portions allowing corrupt portions to be re-written.

For more details on OTA updates on the BQ27Z855 device, refer to the BQ27Z855 Technical Reference Manual.

6.3.20 Configuration

The device supports accurate data measurements and data logging of several key parameters.

6.3.20.1 Cell Voltage Measurements

The BQ27Z855 gas gauge measures the cell voltage at 1s intervals using the VADC. This measured value is internally scaled for the VADC and is calibrated to reduce any errors due to offsets. This data is also used for calculating the impedance of the cell for Dynamic Z-Track™ gas gauging.

6.3.20.2 Coulomb Counting

The device uses an integrating delta-sigma analog-to-digital converter (CCADC) for current measurement. The CCADC measures charge and discharge flow of the battery by measuring the voltage drop across a very small external sense resistor. The CCADC measures a bipolar signal from a range of -100mV to 100mV where a positive value of $V_{\text{SRP}} - V_{\text{SRN}}$ indicates charge current and a negative value indicates discharge current.

The external sense resistor can be as low as $0.5\text{m}\Omega$ and the polarity of the differential voltage determines if the cell is in the CHARGE or DISCHARGE mode.

6.3.20.3 Temperature Measurements

The BQ27Z855 device has an internal temperature sensor (INT_TEMP) for on-die temperature measurements and the ability to support an external temperature measurement using an external NTC connected to the TS pin. These two measurements can be individually enabled and configured via device firmware.

6.4 Device Functional Modes

The BQ27Z855 device supports multiple power modes to accommodate different modes the battery pack can be in and reduce device power consumption:

- In ACTIVE mode, the BQ27Z855 performs measurements, calculations, protection decisions, and data updates in 1s intervals. Between these intervals, the BQ27Z855 is in a reduced power stage to minimize device power consumption. Battery protections are continuously monitored in this mode.
- In SLEEP mode, the BQ27Z855 performs measurements, calculations, protection decisions, and data updates in adjustable time intervals. Between these intervals, the BQ27Z855 is in a reduced power stage. While in SLEEP mode, the device's Coulomb counter is continuously integrating. Battery protections are continuously monitored in this mode. The BQ27Z855 has a wake function that enables exit from SLEEP mode when current flow, a battery protection event, or a failure is detected.
- In DEEP SLEEP mode, the BQ27Z855 performs measurements, calculations, protection decisions, and data updates in adjustable time intervals. Between these intervals, the BQ27Z855 is in a further reduced power stage. While in DEEP SLEEP mode, the device's Coulomb counter turns ON at adjustable time intervals to read current and is OFF in between these measurements. Battery protections are continuously monitored in this mode. The BQ27Z855 has a wake function that enables exit from DEEP SLEEP mode when current flow, a battery protection event, or a failure is detected.
- In SHELF1 mode, the BQ27Z855 is placed in a very low power state for shipping or shelf life purposes. The device measures voltage and temperature very infrequently and at shorter ADC conversion times, and current is not measured or Coulomb counted. Additionally, the CHG and DSG FETs and all hardware-based protections are OFF. Due to this, no external power is available to the system when the gauge is in SHELF1 mode. Current is assumed to be and reported as 0mA. Therefore, the device tracks the battery's state-of-charge from cell voltage or OCV measurements. The measurements performed each interval are cell voltage, temperature, and PACK voltage (every fourth interval). Processing is minimized by reducing the number of calculations. Some calculations are performed less frequently and only after voltage and temperature are measured. These less frequent calculations include updating firmware-based protections, lifetime data, and the voltage and temperature ranges of the Advanced Charge Algorithm. Other calculations, such as updating *RemainingCapacity()* and *FullChargeCapacity()*, are not performed at all with the assumption the system is OFF and cannot communicate with the gauge.
- In SHELF2 mode, the BQ27Z855 is placed in an even lower power state than SHELF1 mode for shipping or shelf life purposes. The device wakes up at an adjustable time interval to perform measurements, calculations, and, if needed, data updates then immediately enters a SHUTDOWN-like state to be in during these intervals where only the minimum number of blocks are ON. The device uses the LFO for timekeeping to determine when the next wake interval is reached and how long the device has been in SHELF2 mode. Current is assumed to be and reported as 0mA. Therefore, the device tracks the battery's state-of-charge from cell voltage or OCV measurements. Gauging calculations, such as updating *RemainingCapacity()* and *FullChargeCapacity()*, are not performed at all with the assumption the system is OFF and cannot communicate with the gauge.
- In SHUTDOWN mode, the BQ27Z855 is completely disabled.

7 Application and Implementation

Note

Information in the following applications sections is not part of the TI component specification, and TI does not warrant its accuracy or completeness. TI's customers are responsible for determining suitability of components for their purposes. Customers should validate and test their design implementation to confirm system functionality.

7.1 Application Information

The BQ27Z855 can be used with a 1-series Li-ion or Li-polymer battery pack. To implement and design a comprehensive set of parameters for a specific battery pack, the user needs Battery Management Studio ([BQStudio](#)), which is a graphical user-interface tool installed on a PC during development, and a USB-based PC interface board such as the EV2500 or EV2400 to program and communicate with the gauge. The firmware installed in the product has default values, which are summarized in the associated BQ27Z855 Technical Reference Manual. Using the BQStudio tool, these default values can be changed to cater to specific application requirements during development once the system parameters, such as enable or disable certain features for operation, cell configuration, chemistry that best matches the cell used, and more. The final flash image, which is extracted once configuration and testing are complete, is used for mass production and is referred to as the "golden image."

7.2 Typical Application Schematics

The following are example BQ27Z855 application schematics for a single-cell battery pack.

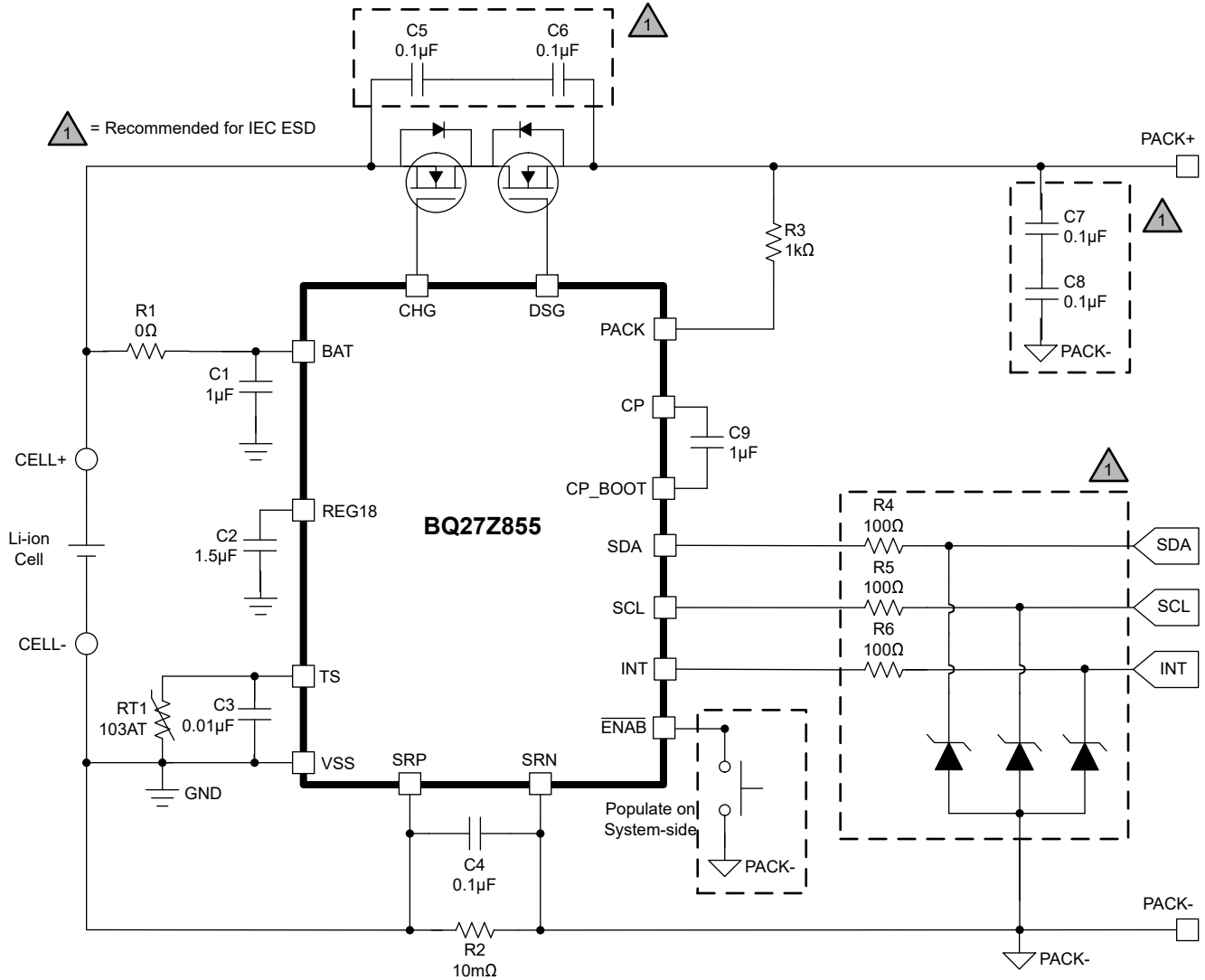

Figure 7-1. BQ27Z855 Typical Application Schematic with Low Side Current Sensing

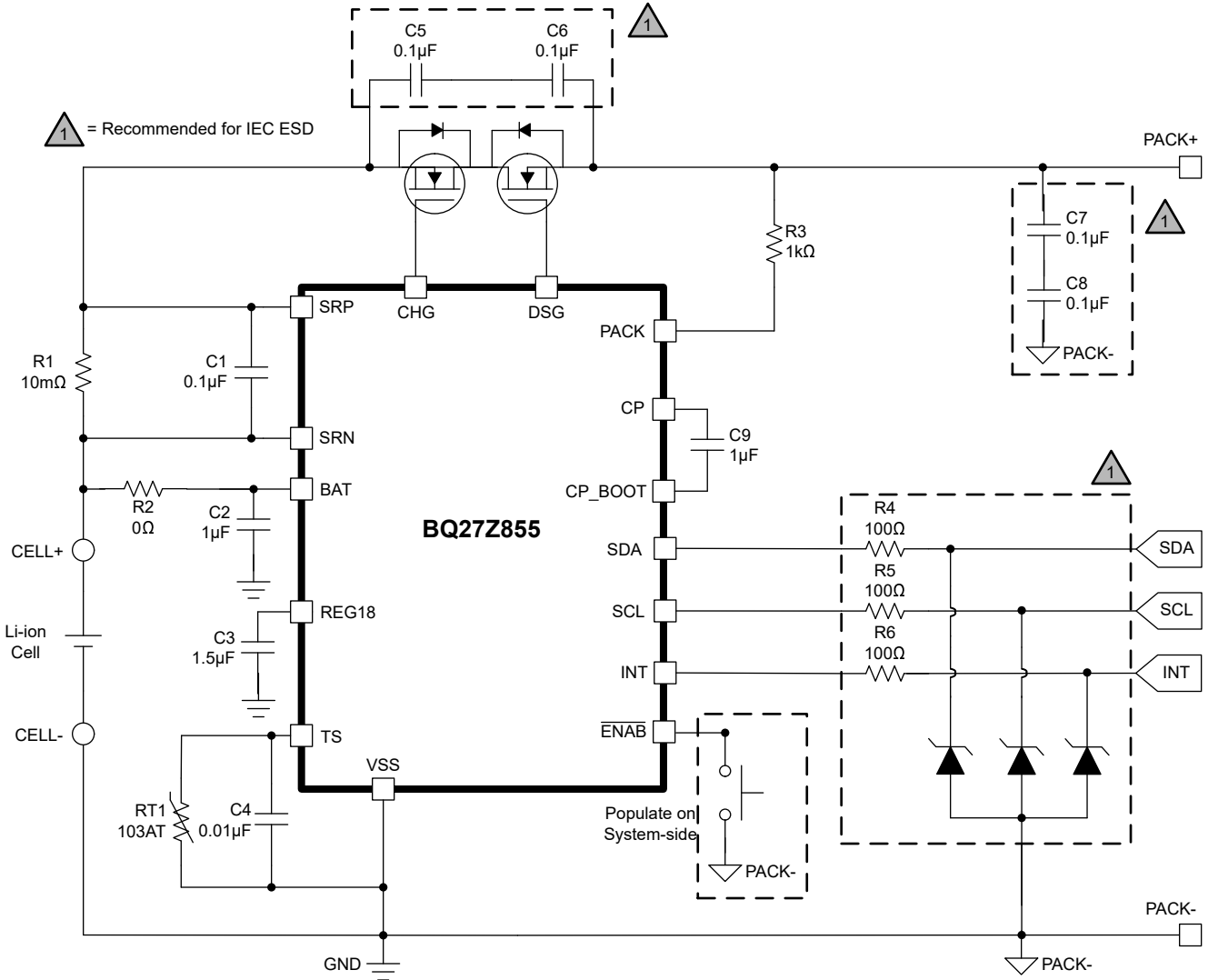

Figure 7-2. BQ27Z855 Typical Application Schematic with High Side Current Sensing

7.2.1 Design Requirements

Table 7-1 shows the default settings for the main parameters. Use the bqStudio tool to update the settings to meet the specific application or battery pack configuration requirements.

The device should be calibrated before any gauging test. Follow the bqStudio **Calibration** page to calibrate the device, and use the bqStudio **Chemistry** page to update the chemistry profile on the device.

Table 7-1. Example Design Parameters

Design Parameter	Example
Cell Configuration	1S1P: 1 series with 1 parallel
Design Capacity	250mAh
Device Chemistry	Li-Ion
Cell Undervoltage	2500mV
Cell Overvoltage at Standard Temperature	4400mV
Shutdown Voltage	2300mV
Overcurrent in CHARGE Threshold	1000mA
Overcurrent in DISCHARGE Threshold	-1000mA

Table 7-1. Example Design Parameters (continued)

Design Parameter	Example
Short Circuit in DISCHARGE Threshold	-1500mA
Internal and External Temperature Sensor	Only External Temperature Sensor used
Undertemperature in CHARGE Threshold	0°C
Undertemperature in DISCHARGE Threshold	0°C
Zero-volt Charge Exit Threshold	2400mV
Zero-volt PACK Threshold	1500mV
Precharge Current	50mA
Charging Voltage Low	2900mV
Falling Precharge Entry Voltage	2500mV
Charging Current at Standard Temperature	250mA
Charging Voltage at Standard Temperature	4200mV
Termination Current	25mA
Recharge Voltage	100mV
MINSYS Voltage Threshold	3800mV
BROADCAST Mode	Disabled

The design parameters needed to fit the design requirements can be adjusted in the device firmware. For more information on particular design parameters, refer to the BQ27Z855 Technical Reference Manual.

7.2.2 Detailed Design Procedure

7.2.2.1 High-Current Path

The high-current path begins at the PACK+ terminal of the battery pack. As charge current travels from the PACK+ terminal, it finds its way through protection FETs, the battery cell and cell connections, the sense resistor, and then returns to the PACK– terminal. In addition, some components are placed across the PACK+ and PACK– terminals to reduce effects from electrostatic discharge.

7.2.2.1.1 Protection FETs

The BQ27Z855 device supports driving external N-channel protection FETs using integrated NFET drivers. Select the N-channel CHG and DSG FETs for a given application.

If the device's current limiter is enabled, select the N-channel CHG and DSG FETs based on the FET parameter guidelines outlined in [Section 7.2.2.3.1](#) to ensure proper linear charging functionality.

The gates of the CHG and DSG protection FETs are pulled to the device GND reference (VSS) to ensure the FETs are turned off if the gate drive is open.

Capacitors C5 and C6 help protect the FETs during an ESD event. Using two devices ensures normal operation if one capacitor becomes shorted. For more robust ESD performance, the copper trace inductance of the capacitor leads must be designed to be as short and wide as possible. Ensure that the voltage rating of both C5 and C6 are adequate to hold off the applied voltage if one of the capacitors becomes shorted.

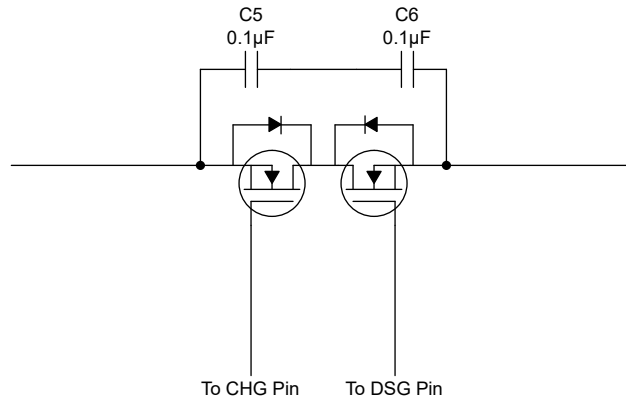

Figure 7-3. Protection FETs

7.2.2.1.2 Battery Cell Connections

The high current flows through the top and bottom connections of the battery cell. Therefore, the voltage sense leads at these points must be made with a Kelvin connection to avoid any errors due to a voltage drop caused by the copper trace. The location marked 1P in Figure 7-4 indicates the Kelvin connection at the positive terminal of the cell. This Kelvin connection to the device's BAT pin also reduces the trace resistance between the connection point and the input power supply of the device.

The Kelvin connection at 1N to the low-current ground is needed to avoid an undesired voltage drop through long traces while the gas gauge is measuring the cell voltage.

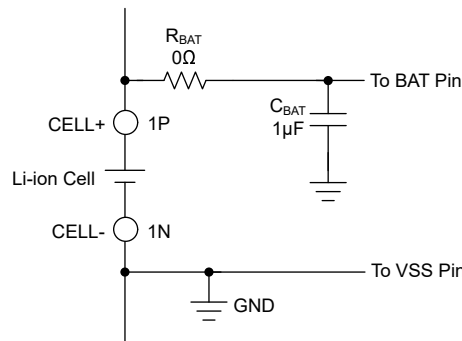

Figure 7-4. Battery Cell Connections

7.2.2.1.3 Sense Resistor

As with the cell connections, the quality of the Kelvin connections at the sense resistor is critical. The sense resistor must have a temperature coefficient no greater than 50ppm in order to minimize current measurement drift with temperature. Choose the value of the sense resistor to correspond to the available overcurrent and short circuit protection ranges and desired protection threshold setting of the BQ27Z855. It is recommended to select the smallest value possible for a given application to minimize the negative voltage generated on the BQ27Z855 V_{SS} node during a short circuit in discharge event. This pin has an absolute minimum voltage of $-0.3V$.

Parallel resistors can be used as long as good Kelvin sensing is ensured. The device is designed to support a minimum sense resistor value of $0.5m\Omega$.

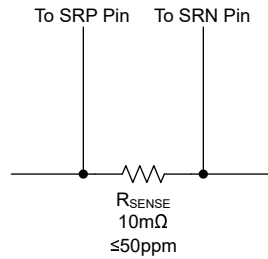

Figure 7-5. Sense Resistor

7.2.2.1.4 ESD Mitigation

A pair of series 0.1 μF ceramic capacitors (C7 and C8) is placed across the PACK+ and PACK– terminals to help in the mitigation of external system-level electrostatic discharges. The two devices in series ensure continued operation of the battery pack if one of the capacitors becomes shorted.

7.2.2.2 Gas Gauge Circuit

The gas gauge circuit includes the BQ27Z855 and its peripheral components. These components are divided into the following groups:

- Cell voltage measurement interface
- Coulomb counter interface
- Temperature measurement
- 1.8V LDO (REG18)
- I²C communication
- Interrupt to host interface via the INT pin

7.2.2.2.1 Cell Voltage Measurement Interface

The cell input is conditioned with a bypass capacitor (C_{BAT}) with a recommended typical value of 1 μF connected between the device's BAT pin and GND reference (VSS). This capacitor acts to filter unwanted voltage transients and provides some ESD protection during cell connect. The BQ27Z855 device uses the BAT pin as the device's power source, so this bypass capacitor connected between the device's BAT pin and V_{SS} also acts to filter unwanted voltage ripples at the input of the device's internal 1.8V LDO.

A 0 Ω resistor (R_{BAT}) can be placed between the positive terminal of the cell and device BAT pin if needed to split the net names, but a higher resistor value is not recommended to ensure the proper linear charger functionality and entry in and out of supplement mode. See [Section 7.2.2.3.2](#) and [Section 7.2.2.3.3](#) for more details.

Also, as described in [Figure 7-4](#), the top node of the cell must be sensed at the battery connections with a Kelvin connection to prevent voltage sensing errors caused by a voltage drop from the PCB copper trace.

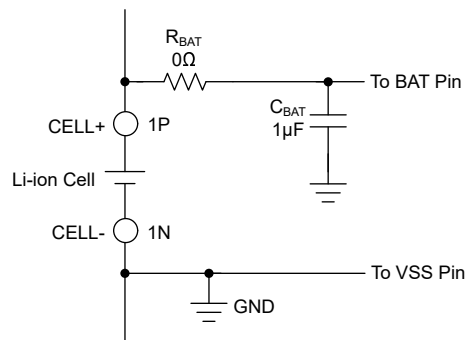

Figure 7-6. Cell Voltage Measurement Input

7.2.2.2.2 Coulomb Counter Interface

The BQ27Z855 uses an integrating delta-sigma ADC, or Coulomb counter, for current measurements. For more robust noise immunity, a capacitor can be added between the device's SRP and SRN pins to provide some low-pass filtering. Place a 0.1µF (C_{CCADC}) filter capacitor across the SRP and SRN inputs.

One key item to consider when choosing a sense resistor value is the tradeoff between the sense resistor value and the current resolution the device's Coulomb counter will report for gauging calculations. This tradeoff is detailed as follows:

- A higher sense resistor value yields a lower current resolution and can be more appropriate for applications using lower battery capacities and or lower currents
- A lower sense resistor value yields a higher current resolution and can be more appropriate for applications using higher battery capacities and or higher currents

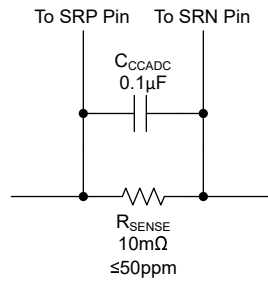

Figure 7-7. Coulomb Counter Interface

7.2.2.2.3 Temperature Measurement

For the BQ27Z855 device, the TS pin provides an internal thermistor bias network under firmware control in order to measure cell temperature using an external NTC thermistor. The TS pin can be enabled with an integrated 18kΩ (TYP) linearization pull-up resistor to support the use of a 10kΩ at 25°C NTC external thermistor such as a Semitec 103AT-2. The BQ27Z855 device supports one external thermistor.

Optionally, a small 0.01µF capacitor (C_{TS}) can be connected in parallel to the external NTC thermistor for more robust noise immunity during temperature measurement and ESD performance.

The BQ27Z855 device also includes an internal temperature sensor that can be used in place of or in addition to an external thermistor. This internal temperature sensor can be enabled and disabled via device firmware.

Temperature-based protection settings can be configured via device firmware. Refer to the BQ27Z855 Technical Reference Manual for more details.

If the TS pin is unused, connect the pin to VSS or leave floating and configure data flash accordingly to disable measuring temperature on the unused TS pin. If the internal temperature sensor is unused, configure data flash accordingly to disable the sensor.

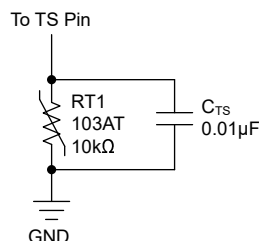

Figure 7-8. External NTC Thermistor Support

7.2.2.2.4 1.8V Low Dropout Regulator (REG18)

The BQ27Z855 includes a 1.8V low dropout regulator to support the device and provide regulated supply voltage for the device CPU and internal digital logic.

A capacitor (C_{REG18}) with the recommended typical capacitance of $1.5\mu\text{F}$ is required to be connected as close to the REG18 pin as possible for optimal operation.

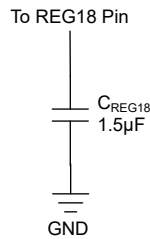

Figure 7-9. REG18 External Capacitor

7.2.2.2.5 I²C Communication (SDA, SCL)

The device's I²C clock and data pins have an absolute maximum voltage rating of 6V and have integrated high-voltage ESD protection circuits. However, adding a Zener diode or ESD TVS diode and 100Ω series resistors can provide more robust ESD performance.

The SDA and SCL pins have internal pull-down resistors. When the gas gauge senses that both lines are low (such as during removal of the battery pack), the device goes into SLEEP mode to conserve power.

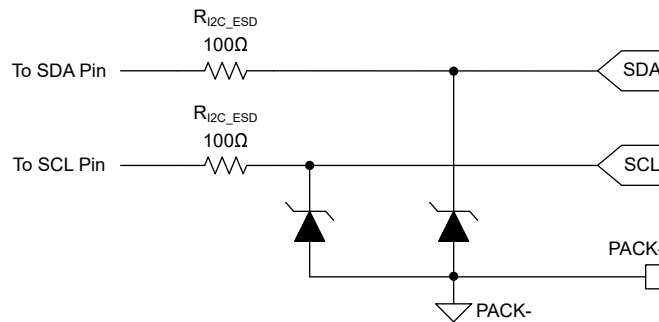

Figure 7-10. ESD Protection for I²C Communication

7.2.2.2.6 Interrupt to Host Interface (INT)

The device's INT pin also has an absolute maximum voltage rating of 6V and integrated high-voltage ESD protection circuits. Similar to the I²C pins, a Zener diode or ESD TVS diode and a 100Ω series resistor can be added for more robust ESD performance.

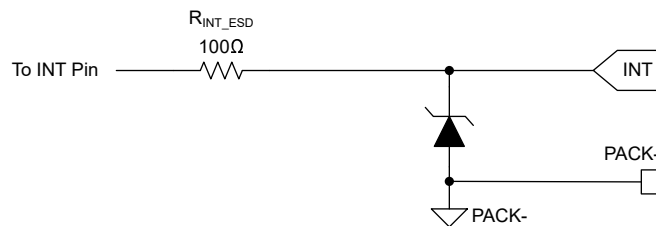

Figure 7-11. ESD Protection for INT Output to System-side Host

7.2.2.3 Current Limiter Circuit

The current limiter circuit includes the BQ27Z855 and its peripheral components. These components are divided into the following groups:

- Protection FETs
- CP control logic and capacitor
- Voltage-based feedback interface

- Current-based feedback interface
- BAT-PACK dedicated voltage comparator (DCOMP)

7.2.2.3.1 Protection FETs and Compatibility with BQ27Z855

The BQ27Z855 device supports driving external N-channel protection FETs using integrated NFET drivers. When the device's current limiter feature is enabled, the device controls the CHG FET in a linear operating mode to function as a linear charger. To ensure proper charging functionality by the device's current limiter, select the N-channel CHG and DSG FETs for a given application based on the following NFET parameters typically specified in the FET datasheet:

1. The gate resistance (R_G) of the CHG FET
2. The input capacitance (C_{ISS}) of the CHG FET

For the selected NFETs to be compatible with the BQ27Z855 device, the product of R_G and C_{ISS} must be less than $7\mu\Omega \times F$. In other words:

$$R_G \times C_{ISS} < 7\mu\Omega \times F = R_G \times (C_{GS} + C_{GD}) < 7\mu\Omega \times F \quad (1)$$

For example, if the FET's maximum $R_G = 700\Omega$, the FET's maximum C_{ISS} value cannot exceed 10nF.

Following this criteria ensures the device's CC and CV loops remain stable and no unwanted oscillations occur during charging.

Additionally, the thermal performance of the FETs should also be carefully considered based on the battery charging parameters for a particular application.

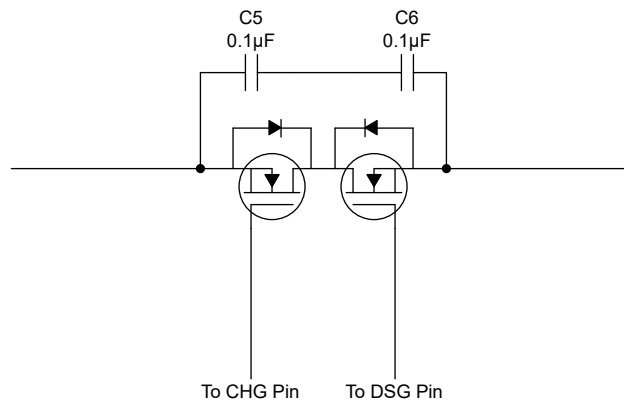

Figure 7-12. Protection FETs for Current Limiting

7.2.2.3.2 CP Control Logic and Capacitor

To support supplement mode and consecutive high system load pulses, the device turns the CHG FET ON using internal control logic and an external capacitor (C_{CP}) connected between the device's CP and CP_BOOT pins. This capacitor is discharged to the device's CHG pin when the device enters the CHG = LIN_ON state and is recharged immediately after the CHG FET turns ON. Additionally if the device's current limiter is enabled, the external C_{CP} capacitor is charged during device operation regardless of whether the device is actively charging a battery.

When the external CP capacitor charges, the capacitor charges using the available battery voltage. To ensure the device properly enters and exits supplement mode, additional resistance between the positive terminal of the cell (CELL+) and the device's BAT pin is not recommended. This prevents unintended device brownouts when the CP capacitor must be recharged in between high system load pulses to support the next entry into supplement mode. The total resistance between CELL+ and the device BAT pin is not recommended to exceed 110mΩ.

Place the external CP capacitor with the recommended typical capacitance of 1μF connected between the CP and CP_BOOT pins as close to the device as possible.

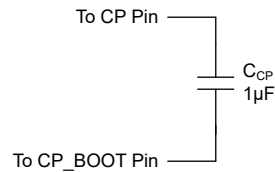

Figure 7-13. CP Capacitor

7.2.2.3.3 Voltage-based Feedback Interface

As stated in [Section 7.2.2.2.1](#), the device measures cell voltage using the device's BAT pin. The measured cell voltage value provides the feedback needed for the device's current limiter to properly regulate charging current and charging voltage.

There are no additional external components required at the device's BAT pin to support the current limiter functionality besides the required components stated in [Section 7.2.2.2.1](#).

In addition to the recommendation on the total resistance between CELL+ and the device BAT pin stated in [Section 7.2.2.3.2](#), the following resistances should also be carefully considered to ensure proper charging and supplement mode behavior:

- The parasitic resistance between the BAT capacitor (C_{BAT}) and device BAT pin is not recommended to exceed 60mΩ
- The connection resistance between CELL+ and the C_{BAT} capacitor is not recommended to exceed 140mΩ

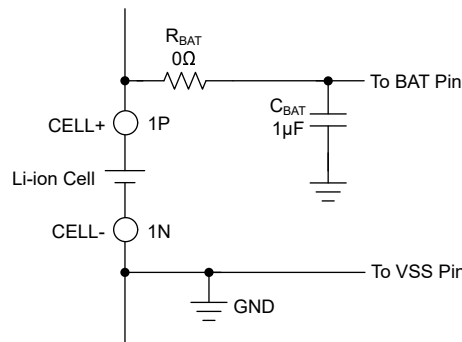

Figure 7-14. Voltage-based Feedback Interface

7.2.2.3.4 Current-based Feedback Interface

As stated in [Section 7.2.2.2.2](#), the device uses an integrating delta-sigma ADC, or Coulomb counter, for current measurements by converting the voltage difference across a sense resistor between the SRP and SRN terminals. The measured current value provides the feedback needed for the device's current limiter to properly regulate charging current and charging voltage.

There are no additional external components required at the device's SRP and SRN pins to support the current limiter functionality besides the required components stated in [Section 7.2.2.2.2](#).

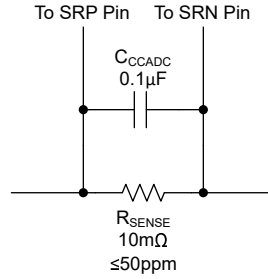

Figure 7-15. Current-based Feedback Interface

7.2.2.3.4.1 Sense Resistor Impact on Current-based Feedback

As stated in [Section 7.2.2.2.2](#), choosing a sense resistor (R_{SENSE}) value presents a tradeoff between the sense resistor value and the current resolution reported by the device's Coulomb counter for gauging calculations. This tradeoff is also present when the device's current limiter is enabled and impacts the current resolution the device senses and regulates charging current at.

This tradeoff is detailed as follows:

- A higher sense resistor value yields a lower current resolution and can be more appropriate for applications using lower battery capacities and or lower charging currents
- A lower sense resistor value yields a higher current resolution and can be more appropriate for applications using higher battery capacities and or higher charging currents

Using a combination of a particular sense resistor value and particular charging currents impacts the charging current resolution of the device since the device's battery charging functionality scales based on the sense resistor value.

In addition to the resolution, the sense resistor value also impacts the minimum charging current setting to achieve particular charging current accuracy. As a general guideline to achieve charging current accuracy of $\pm 10\%$, the charging current settings programmed in device data flash is not recommended to be below the minimum values given in [Table 7-2](#). Charging current settings below the recommended range when using a particular sense resistor value can still be programmed, but charging current regulated by the device may not be as accurate as $\pm 10\%$. The charging current programmed in device data flash should also not exceed $I_{CHG(MAX)}$ as specified in the [Current Limiter Specifications table](#). The combination of sense resistor value and charging current settings should be considered carefully then.

The sense resistor value's impact on charging current resolution and accuracy should be considered when programming the fast charge and precharge current settings in device data flash.

[Table 7-2](#) provides guidance on how the sense resistor value impacts the charging current (I_{CHG}) resolution and recommended range of the device:

Table 7-2. I_{CHG} Resolution and Accuracy Versus R_{SENSE}

	0.5mΩ	1mΩ	2mΩ	5mΩ	10mΩ	20mΩ	50mΩ	100mΩ
I_{CHG} Resolution (mA)	29.30	14.65	7.32	2.93	1.46	0.73	0.29	0.15
Minimum I_{CHG} Setting (mA) ⁽¹⁾	925	463	231	93	46	23	9	5

(1) General guideline on minimum I_{CHG} setting to achieve $\pm 10\%$ I_{CHG} accuracy. Programming lower currents in device data flash may not be as accurate.

A lower termination current (I_{TERM}) setting below the recommended I_{CHG} range is allowed, but should not exceed $I_{TERM(MAX)}$ as specified in the [Current Limiter Specifications table](#). Similar to the above general guideline to achieve $\pm 10\%$ I_{CHG} accuracy, the I_{TERM} setting programmed in device data flash is not recommended to

be below the minimum values given in [Table 7-3](#) to achieve $\pm 10\%$ I_{TERM} accuracy. I_{TERM} settings below the recommended range when using a particular sense resistor value can still be programmed, but the I_{TERM} value detected by the device may not be as accurate as $\pm 10\%$.

[Table 7-3](#) provides guidance on how the sense resistor value impacts the I_{TERM} resolution and recommended range of the device:

Table 7-3. I_{TERM} Resolution and Accuracy Versus R_{SENSE}

	0.5m Ω	1m Ω	2m Ω	5m Ω	10m Ω	20m Ω	50m Ω	100m Ω
I_{TERM} Resolution (mA)	1.85	0.92	0.46	0.18	0.09	0.05	0.02	0.01
Minimum I_{TERM} Setting (mA) ⁽¹⁾	55	28	14	6	3	1	1 ⁽²⁾	1 ⁽²⁾

- (1) General guideline on minimum I_{TERM} setting to achieve $\pm 10\%$ I_{TERM} accuracy. Programming lower currents in device data flash may not be as accurate.
- (2) There is no recommended minimum I_{TERM} value to consider with this R_{SENSE} to achieve $\pm 10\%$ I_{TERM} accuracy. The programmable step size and minimum nonzero setting for **Charge Term Taper Current** in device data flash is 1mA.

7.2.2.3.4.2 Sense Resistor Impact on CHG FET State Transitions

The value of the sense resistor also impacts when the device can trigger a CHG FET state transition in Linear or Ideal Diode mode. The device uses a Coulomb counter-based charge current measurement digital filter (CC3) to detect when $V_{SRP} - V_{SRN} \geq V_{TH_OFF_FINE}$ to turn the CHG FET OFF. Since any positive or charging current flowing through the sense resistor creates a differential voltage across the sense resistor, the CC3 digital filter effectively triggers a CHG FET state transition at higher or lower detected charging current based on the value of R_{SENSE} .

This tradeoff in the "detected charging current threshold" caused by the value of R_{SENSE} is detailed as follows:

- A higher R_{SENSE} value yields a lower detected charging current threshold
- A lower R_{SENSE} value yields a higher detected charging current threshold

For example, with a combination of $V_{TH_OFF_FINE} = 450\mu V$ and $R_{SENSE} = 20m\Omega$ the device's CC3 digital filter can detect charging currents as low as 22.5mA to turn the CHG FET OFF (CHG = LIN_OFFFT in Linear mode or CHG = ID_OFF in Ideal Diode mode). Using $R_{SENSE} = 1m\Omega$ increases this "detected charging current threshold" to 450mA.

This consideration is particularly crucial for Ideal Diode mode if the device needs to detect smaller charge currents to turn the CHG FET OFF when a valid input voltage source is connected at PACK+.

7.2.2.3.5 BAT-PACK Dedicated Voltage Comparator (DCOMP)

The BQ27Z855 device uses an integrated dedicated voltage comparator (DCOMP) to assess the difference in voltage between V_{BAT} and V_{PACK} . This DCOMP is used to control the state of the CHG FET depending on several system parameters when the device is in Linear mode and Ideal Diode mode.

The differential voltage DCOMP senses and compares the voltage thresholds (V_{TH_ON} and V_{TH_OFF}) to transition between CHG FET states is based on the voltage from node A to node B as seen in [Figure 7-16](#).

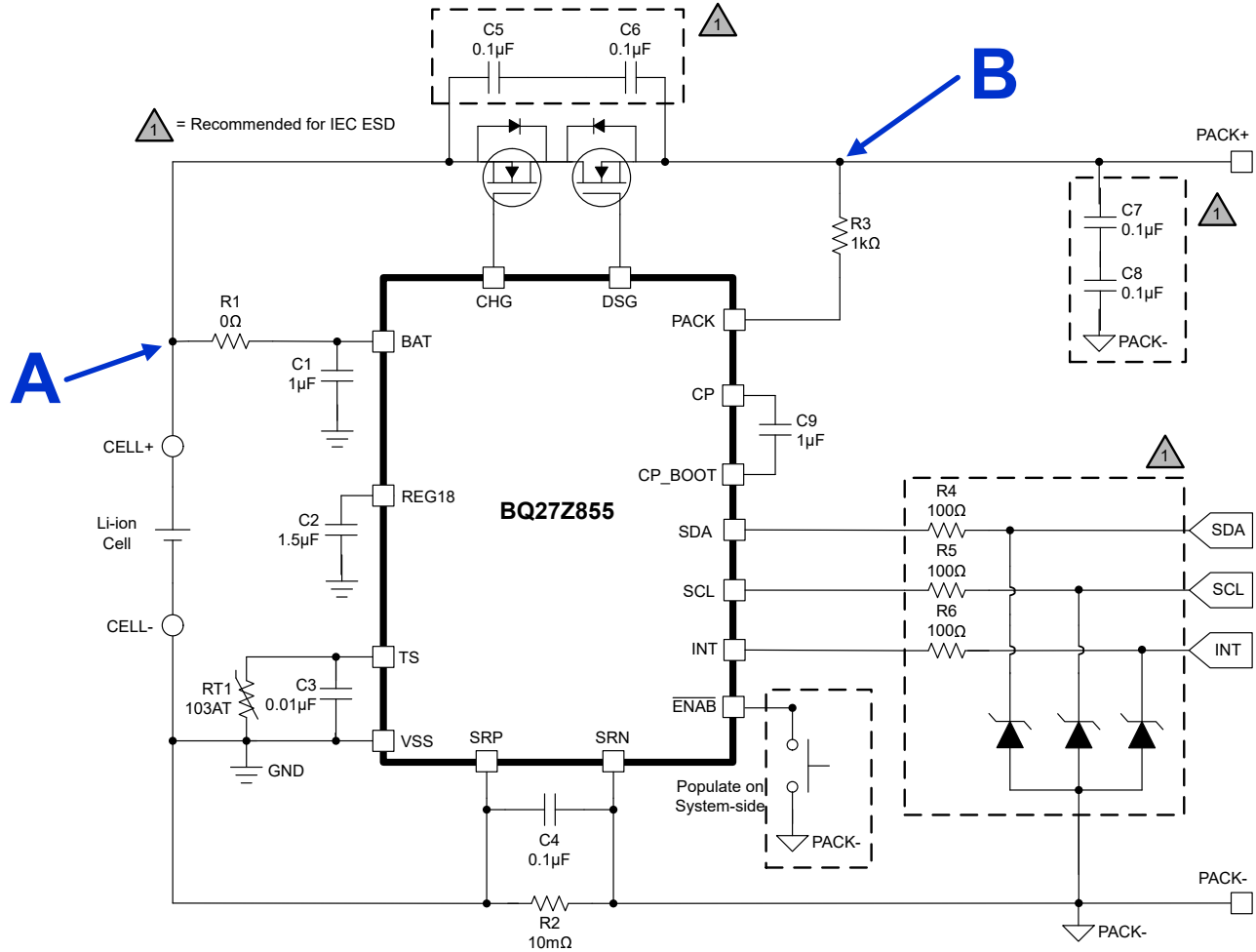

Figure 7-16. DCMP Sense Points

To ensure optimal DCMP sensing performance, the total external resistance (including parasitic resistance) and parasitic capacitance between node B and the device PACK pin is not recommended to exceed a time constant value of 20ns.

The resistor divider network or total resistance between the DCMP sense points at node A and node B (designated in red in Figure 7-17) determines the actual voltage sensed by the device's DCMP input.

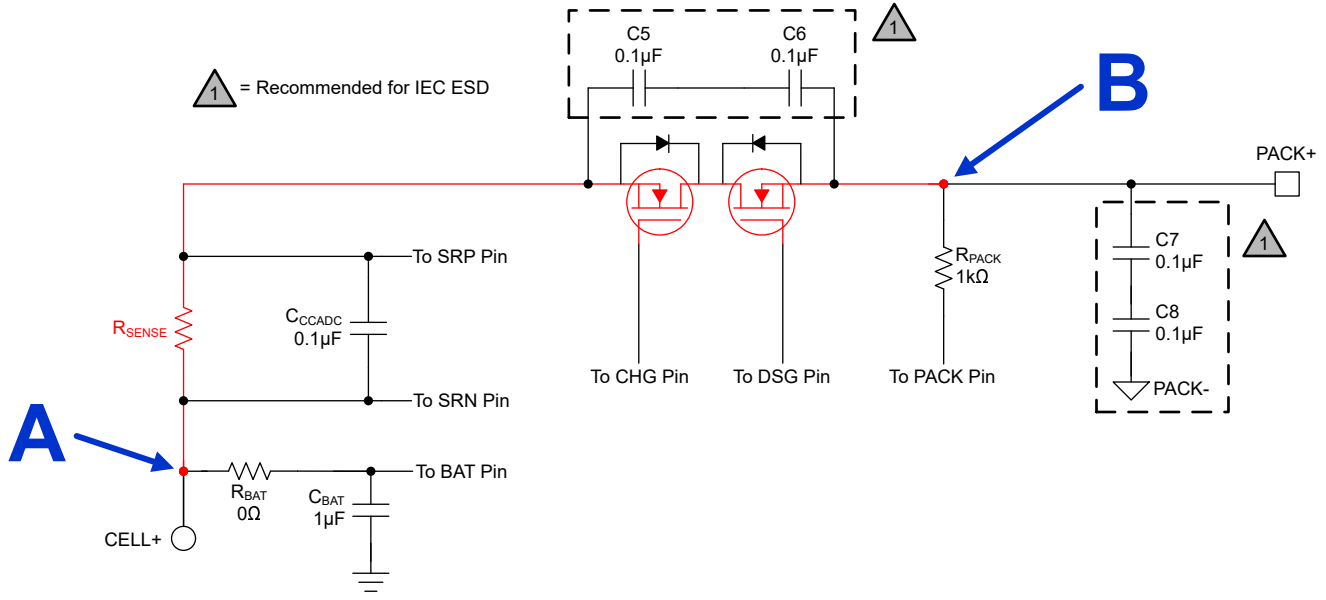

Figure 7-17. DCOMP Sense Resistances

In other words, for the device to transition between CHG FET states within Linear and Ideal Diode modes, DCOMP effectively triggers a CHG FET state transition based on the current flowing from PACK+ to CELL+ or vice versa. This "effective current threshold" (or " $I_{TRIGGER}$ ") is determined based on the following:

1. Voltages at the sense points of node A (device BAT pin) to node B (device PACK pin)
2. Total resistance between the BAT and PACK sense points, including all parasitic resistances ($R_{PACK-TO-BAT}$)

At what current DCOMP can trigger the CHG FET to turn ON or OFF is then determined by:

$$I_{TRIGGER} \geq \frac{V_{TH_X}}{R_{PACK-TO-BAT}} \quad (2)$$

Where:

V_{TH_X} can be either V_{TH_ON} or V_{TH_OFF} depending on if the device is in Linear or Ideal Diode mode as stated in the [Current Limiter Specifications table](#).

7.2.3.5.1 Impact of Sense Resistor Configuration on DCOMP Sensing

When using the current limiter function of the BQ27Z855 device, a key aspect to consider is whether to configure the external sense resistor between the SRP and SRN terminals for low-side or high-side current sensing. The location of the sense resistor presents a tradeoff of at what "effective current threshold" ($I_{TRIGGER}$) the device's DCOMP will trigger CHG FET state transitions. This is because the location of the sense resistor impacts the total resistance between the BAT and PACK sense points ($R_{PACK-TO-BAT}$) of the DCOMP.

If the sense resistor is configured as high-side, the sense resistor value contributes to the $R_{PACK-TO-BAT}$ value. This results in a decreased $I_{TRIGGER}$ threshold at which the DCOMP turns the CHG FET ON or OFF.

For example as seen in the below [Figure 7-18](#) diagram, the sense resistor is included within the total $R_{PACK-TO-BAT}$ designated in red. If the device is in Ideal Diode mode and currently in the CHG = ID_ON state, then the voltage threshold for DCOMP to transition the CHG FET state from CHG = ID_ON to CHG = ID_OFF is $V_{TH_OFF} = 5mV$. In this example, if the sense resistor value is $20m\Omega$ and the combined source-to-source On resistance of the protection FETs and all parasitic resistance between the BAT and PACK sense points is $5m\Omega$, $I_{TRIGGER}$ is then the following:

$$I_{TRIGGER} \geq \frac{V_{TH_X}}{R_{PACK-TO-BAT}} = \frac{V_{TH_OFF}}{R_{SENSE} + R_{SS(ON)} + R_{PARASITIC}} \quad (3)$$

$$I_{\text{TRIGGER}} \geq \frac{5\text{mV}}{20\text{m}\Omega + 5\text{m}\Omega} \quad (4)$$

$$I_{\text{TRIGGER}} \geq 200\text{mA} \quad (5)$$

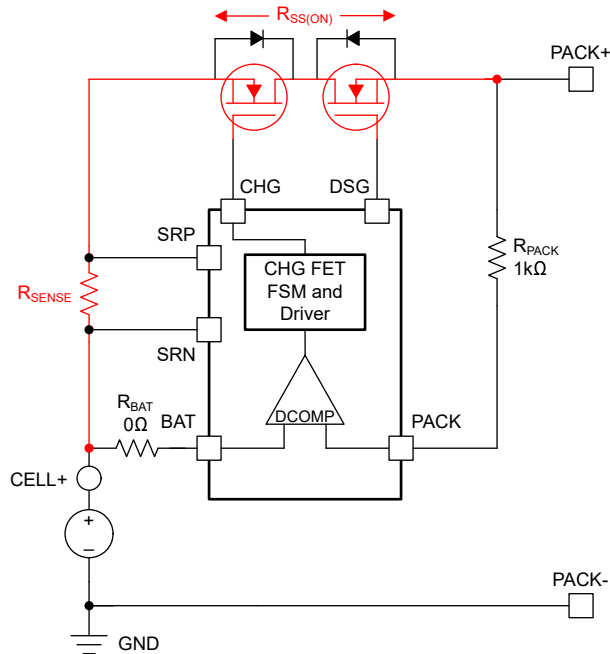

Figure 7-18. DCOMP Sense Resistances with High-side Current Sensing

If the sense resistor is configured as low-side, the sense resistor value does not contribute to the $R_{\text{PACK-TO-BAT}}$ value. This results in an increased I_{TRIGGER} threshold at which the DCOMP turns the CHG FET ON or OFF.

For example as seen in the below Figure 7-19 diagram, the sense resistor is not included within the total $R_{\text{PACK-TO-BAT}}$ designated in red. Using the same example scenario and parameter values described above in the high-side sense resistor case, the total $R_{\text{PACK-TO-BAT}}$ value would now decrease by the example $R_{\text{SENSE}} = 20\text{m}\Omega$ in this low-side sense resistor case. The I_{TRIGGER} threshold then becomes the following:

$$I_{\text{TRIGGER}} \geq \frac{V_{\text{TH_X}}}{R_{\text{PACK-TO-BAT}}} = \frac{V_{\text{TH_OFF}}}{R_{\text{SS(ON)}} + R_{\text{PARASITIC}}} \quad (6)$$

$$I_{\text{TRIGGER}} \geq \frac{5\text{mV}}{5\text{m}\Omega} \quad (7)$$

$$I_{\text{TRIGGER}} \geq 1\text{A} \quad (8)$$

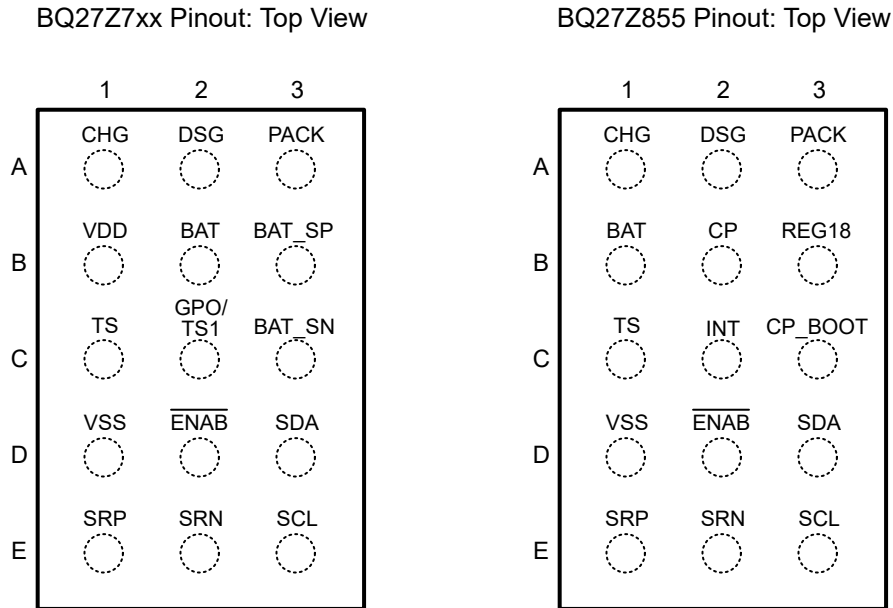

Figure 7-20. BQ27Z7xx v. BQ27Z855 Pinouts

Table 7-4. BQ27Z7xx v. BQ27Z855 Equivalent Pin Map

PIN NO.	BQ27Z7xx Pin	Equivalent Pin on BQ27Z855
A1	CHG	CHG
A2	DSG	DSG
A3	PACK	PACK
B1	VDD	BAT
B2	BAT	BAT
B3	BAT_SP	N/A
C1	TS	TS
C2	GPO/TS1	INT: No extra TS1 function
C3	BAT_SN	N/A
D1	VSS	VSS
D2	ENAB	ENAB
D3	SDA	SDA
E1	SRP	SRP
E2	SRN	SRN
E3	SCL	SCL

7.2.2.4.2 Co-layout Example

Figure 7-21 illustrates an example co-layout between the BQ27Z855 device and the BQ27Z7xx family of TI gas gauge devices that can accommodate both devices so one device can be a drop-in replacement for the other. This example co-layout uses the pinout of the BQ27Z855 and low side current sensing configuration.

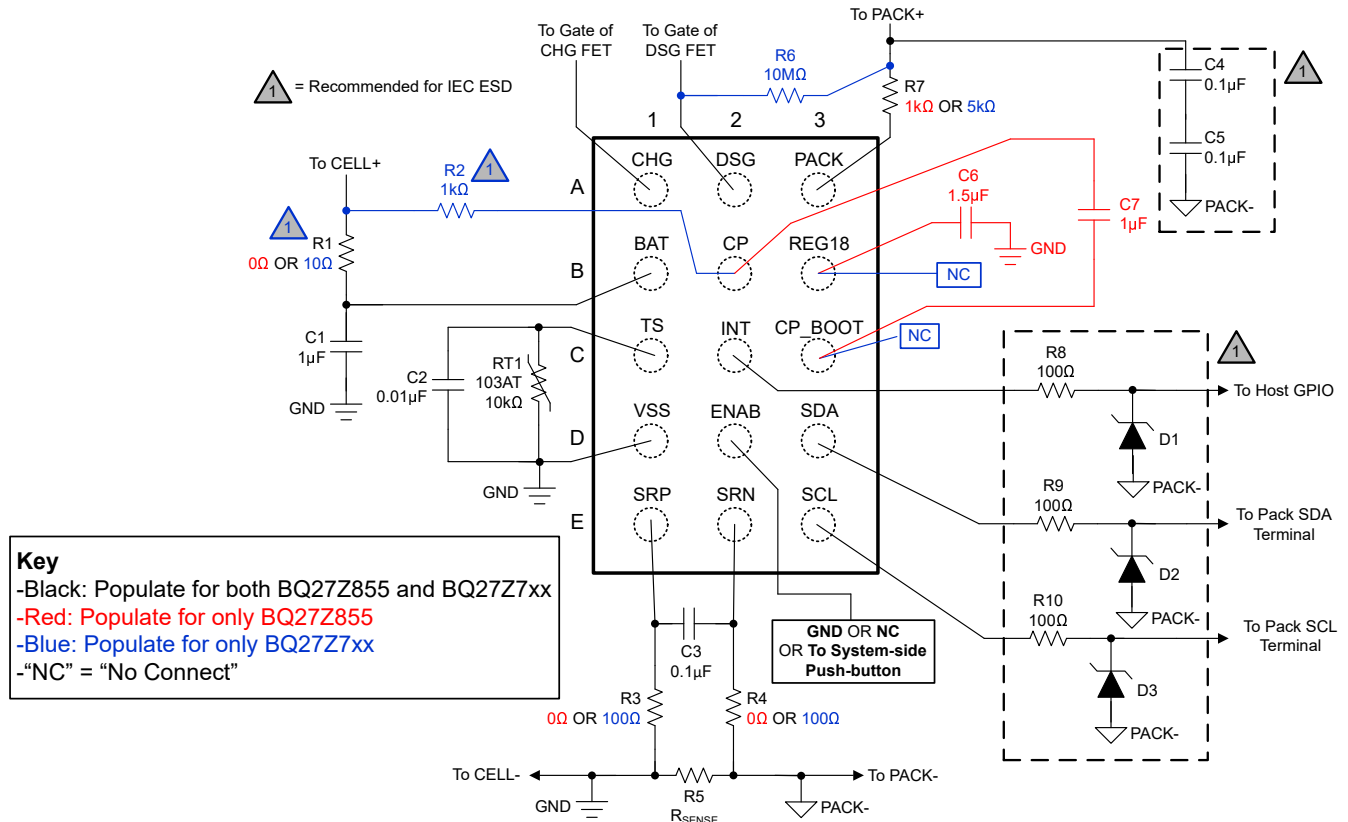

Figure 7-21. BQ27Z855 and BQ27Z7xx Co-layout Example

Table 7-5 details the differences in external components between the BQ27Z855 device and the BQ27Z7xx family of devices.

Table 7-5. BQ27Z855 v. BQ27Z7xx External Components

Component	TYP Value for BQ27Z855	TYP Value for BQ27Z7xx
R1 ⁽¹⁾	0Ω	10Ω
R2 ⁽¹⁾	DNP	1kΩ
R3	0Ω	100Ω
R4	0Ω	100Ω
R5	R _{SENSE}	R _{SENSE}
R6	DNP	10MΩ
R7	1kΩ	5kΩ
R8 ⁽¹⁾	100Ω	100Ω
R9 ⁽¹⁾	100Ω	100Ω
R10 ⁽¹⁾	100Ω	100Ω
C1	1μF	1μF
C2	0.01μF	0.01μF
C3	0.1μF	0.1μF
C4 ⁽¹⁾	0.1μF	0.1μF
C5 ⁽¹⁾	0.1μF	0.1μF
C6	1.5μF	DNP
C7	1μF	DNP
RT1	10kΩ	10kΩ
D1 ⁽¹⁾	-	-

Table 7-5. BQ27Z855 v. BQ27Z7xx External Components (continued)

Component	TYP Value for BQ27Z855	TYP Value for BQ27Z7xx
D2 ⁽¹⁾	-	-
D3 ⁽¹⁾	-	-

(1) Recommended for IEC ESD

8 Power Supply Recommendations

The BQ27Z855 device uses the BAT pin as its power source. The BAT pin powers the internal voltage sources and 1.8V LDO that supply references for the device.

A capacitor (C_{BAT}) with the recommended typical capacitance of 1 μ F connected between the BAT and VSS pins is recommended and must be placed as close to the BAT pin as possible.

9 Layout

9.1 Layout Guidelines

- The quality of the Kelvin connections at the sense resistor is critical. The sense resistor must have a temperature coefficient no greater than 50ppm to minimize current measurement drift with temperature. Choose the value of the sense resistor to correspond to the available overcurrent and short circuit protection ranges and desired protection threshold setting of the BQ27Z855. Select the smallest sense resistor value possible to minimize thermal dissipation and still maintain required measurement accuracy. The value of the sense resistor impacts the differential voltage generated across the BQ27Z855 SRP and SRN nodes during a short circuit. These pins have a differential voltage and should not exceed V_{CCADC_IN} of $\pm 0.1V$ for normal operation. Parallel sense resistors can be used as long as good Kelvin sensing is maintained. The device is designed to support a minimum sense resistor value of 0.5m Ω .
- The BAT pin should be tied directly to the positive terminal of the battery cell. The quality of the Kelvin connection to the battery cell is critical. The Kelvin connection at the positive terminal of the cell (CELL+) avoids any errors due to a voltage drop or impact on the input power supply of the device caused by the copper trace. The Kelvin connection to the low-current ground is needed to avoid an undesired voltage drop through long traces while the gas gauge is measuring the cell voltage.
- In reference to the gas gauge circuit, the following features require attention for component placement and layout:
 - BAT decoupling capacitor:** Place a capacitor (C_{BAT}) with the recommended typical capacitance of 1 μ F connected between the BAT and VSS pins as close to the BAT pin as possible.
 - Coulomb counter interface at the SRP and SRN pins:** The BQ27Z855 gas gauge uses an integrating delta-sigma ADC for current measurements. Place a 0.1 μ F filter capacitor across the SRP and SRN pins. Place the capacitor as close as possible to the device. Route the traces from the sense resistor as differential pairs to the filter capacitor and SRP and SRN pins. Adding a ground plane around the filter network can provide additional noise immunity.
 - REG18 decoupling capacitor:** The device's internal 1.8V LDO requires an external decoupling capacitor to support proper device operation. Place a capacitor (C_{REG18}) with the recommended typical capacitance of 1.5 μ F connected between the REG18 and VSS pins as close to the REG18 pin as possible.
 - I²C communication and INT pin ESD external protection:** The I²C clock and data pins and INT pin have integrated high-voltage ESD protection circuits. However, adding a Zener diode and series resistor provides more robust ESD performance. The I²C clock and data lines have internal pull-down resistors. When the gas gauge senses that both lines are low (such as during removal of the pack), the device goes into SLEEP mode to conserve power.
- In reference to the current limiter circuit, the following features require attention for component placement and layout:
 - CP capacitor:** Place a capacitor (C_{CP}) with the recommended typical capacitance of 1 μ F connected between the CP and CP_BOOT pins as close to the device as possible. Any trace resistance between the CELL+ terminal of the battery cell and the device BAT pin must be carefully considered as the total resistance between CELL+ and the device BAT pin is not recommended to exceed 110m Ω to prevent unintended device brownouts during charging.

- **Voltage-based Feedback Interface:** Follow the same layout guidelines stated above for the BAT decoupling capacitor in addition to carefully consideration of the total resistance between the BAT capacitor (C_{BAT}) and device BAT pin and between CELL+ and the C_{BAT} capacitor to ensure proper charging and supplement mode behavior. The parasitic resistance between the C_{BAT} capacitor and device BAT pin is not recommended to exceed 60m Ω . The connection resistance between CELL+ and the C_{BAT} capacitor is not recommended to exceed 140m Ω .
- **Current-based Feedback Interface:** Follow the same layout guidelines stated above for the Coulomb counter interface at the SRP and SRN pins.
- **BAT-PACK DCOMP:** To ensure optimal DCOMP sensing performance, the total external resistance (including parasitic resistance) and parasitic capacitance between the PACK+ node (node B in [Figure 7-16](#)) and the device PACK pin is not recommended to exceed a time constant value of 20ns. Additionally, any parasitic trace resistance between the BAT and PACK sense points of the device must be carefully considered as the parasitic trace resistance impacts at what current the device's DCOMP will trigger a CHG FET state transition.

10 Device and Documentation Support

10.1 Third-Party Products Disclaimer

TI'S PUBLICATION OF INFORMATION REGARDING THIRD-PARTY PRODUCTS OR SERVICES DOES NOT CONSTITUTE AN ENDORSEMENT REGARDING THE SUITABILITY OF SUCH PRODUCTS OR SERVICES OR A WARRANTY, REPRESENTATION OR ENDORSEMENT OF SUCH PRODUCTS OR SERVICES, EITHER ALONE OR IN COMBINATION WITH ANY TI PRODUCT OR SERVICE.

10.2 Documentation Support

10.2.1 Related Documentation

For related documentation, see the following:

- [BQ27Z855 Technical Reference Manual](#)
- [Dynamic Z-Track™ Technology: An Advanced Battery Gauging Algorithm for Dynamic Load Applications](#)
- [Implementation of Elliptic Curve Cryptography Authentication on TI Battery Fuel Gauges](#)
- [IC Package Thermal Metrics \(SPRA953\)](#)

10.3 Trademarks

™ is a trademark of Ti.

All trademarks are the property of their respective owners.

10.4 Electrostatic Discharge Caution



This integrated circuit can be damaged by ESD. Texas Instruments recommends that all integrated circuits be handled with appropriate precautions. Failure to observe proper handling and installation procedures can cause damage.

ESD damage can range from subtle performance degradation to complete device failure. Precision integrated circuits may be more susceptible to damage because very small parametric changes could cause the device not to meet its published specifications.

10.5 Glossary

[TI Glossary](#) This glossary lists and explains terms, acronyms, and definitions.

11 Revision History

DATE	REVISION	NOTES
February 2026	*	Initial Release

12 Mechanical, Packaging, and Orderable Information

The following pages include mechanical, packaging, and orderable information. This information is the most current data available for the designated devices. This data is subject to change without notice and revision of this document. For browser-based versions of this data sheet, refer to the left-hand navigation.

PACKAGE OPTION ADDENDUM
PACKAGING INFORMATION

Orderable part number	Status	Material type	Package Pins	Package qty Carrier	RoHS	Lead finish/Ball material	MSL rating/Peak reflow	Op temp (°C)	Part marking
BQ27Z855YAHR	Active	Preproduction	DSBGA (YAH) 15	3000 LARGE T&R	Y	SAC396	Level-1-260C-UNLIM	-40 to 85	BQ27Z855

Important Information and Disclaimer: The information provided on this page represents TI's knowledge and belief as of the date that it is provided. TI bases its knowledge and belief on information provided by third parties, and makes no representation or warranty as to the accuracy of such information. Efforts are underway to better integrate information from third parties. TI has taken and continues to take reasonable steps to provide representative and accurate information but may not have conducted destructive testing or chemical analysis on incoming materials and chemicals. TI and TI suppliers consider certain information to be proprietary, and thus CAS numbers and other limited information may not be available for release.

In no event shall TI's liability arising out of such information exceed the total purchase price of the TI part(s) at issue in this document sold by TI to Customer on an annual basis.

ADVANCE INFORMATION

12.1 Tape and Reel Information

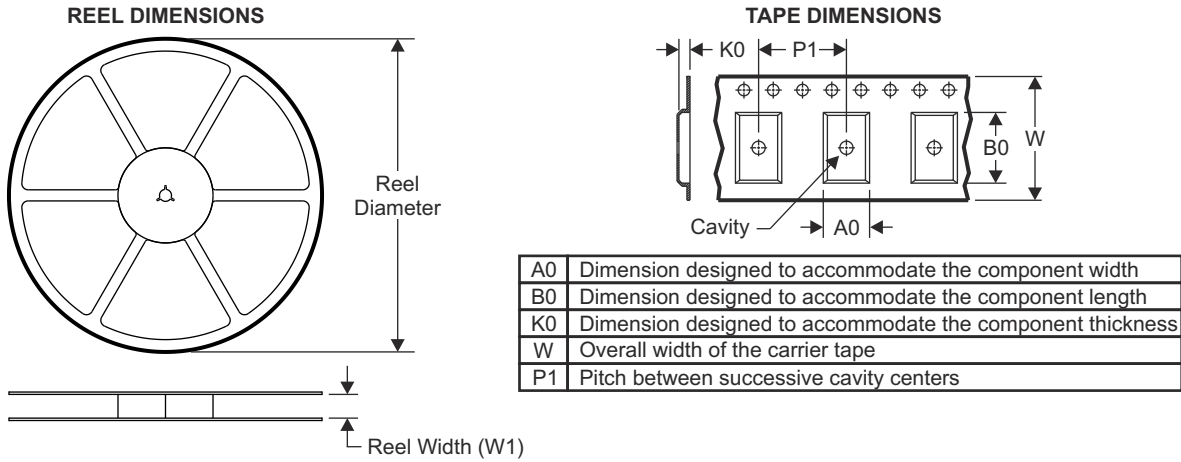

QUADRANT ASSIGNMENTS FOR PIN 1 ORIENTATION IN TAPE

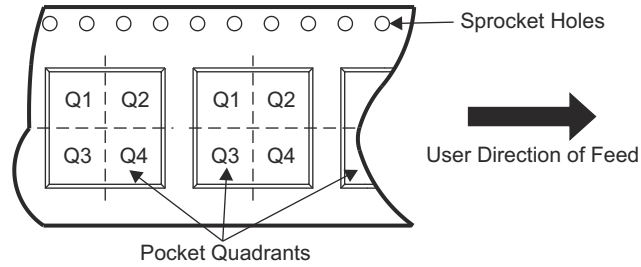

Device	Package Type	Package Drawing	Pins	SPQ	Reel Diameter (mm)	Reel Width W1 (mm)	A0 (mm)	B0 (mm)	K0 (mm)	P1 (mm)	W (mm)	Pin1 Quadrant
BQ27Z855YAHR	DSBGA	YAH	15	3000	180.0	12.4	1.88	2.76	0.55	4.0	12.0	Q1

ADVANCE INFORMATION

TAPE AND REEL BOX DIMENSIONS

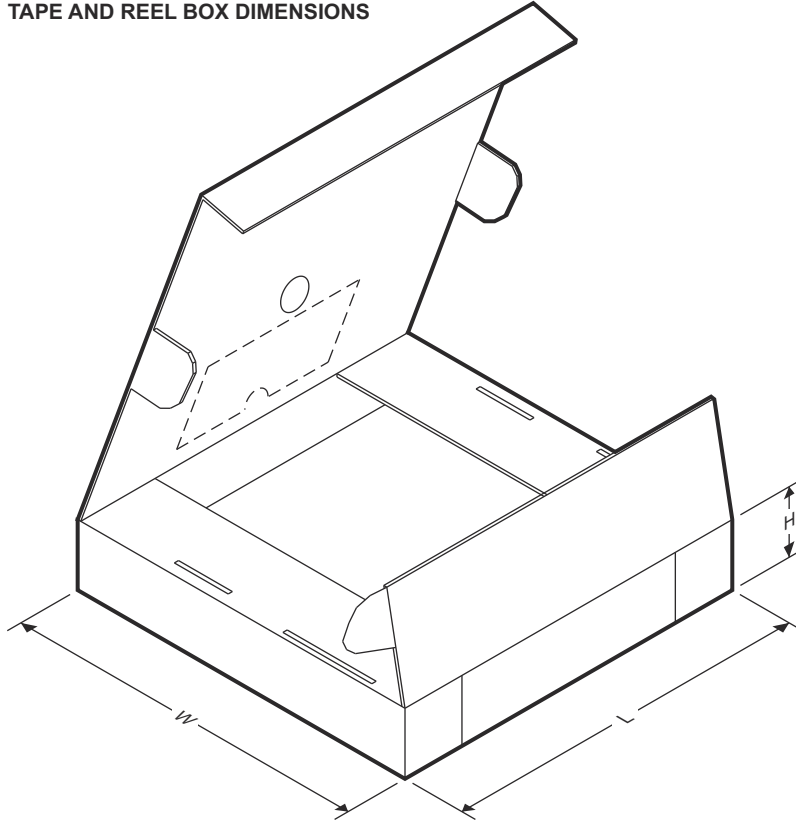

ADVANCE INFORMATION

Device	Package Type	Package Drawing	Pins	SPQ	Length (mm)	Width (mm)	Height (mm)
BQ27Z855YAHR	DSBGA	YAH	15	3000	182.0	182.0	20.0

12.2 Mechanical Data

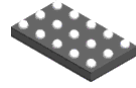

YAH0015

PACKAGE OUTLINE

DSBGA - 0.4 mm max height

DIE SIZE BALL GRID ARRAY

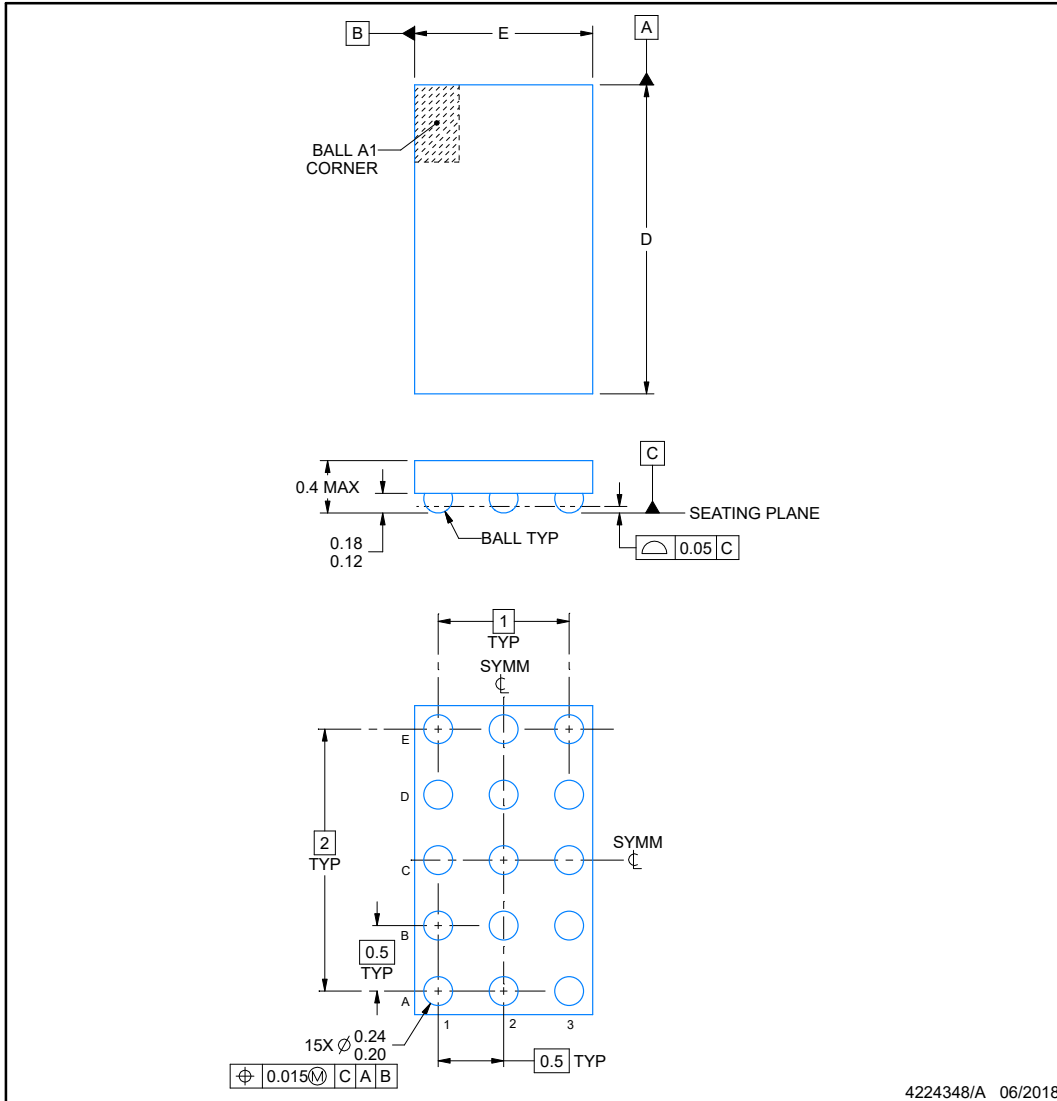

NOTES:

1. All linear dimensions are in millimeters. Any dimensions in parenthesis are for reference only. Dimensioning and tolerancing per ASME Y14.5M.
2. This drawing is subject to change without notice.

ADVANCE INFORMATION

EXAMPLE BOARD LAYOUT

YAH0015

DSBGA - 0.4 mm max height

DIE SIZE BALL GRID ARRAY

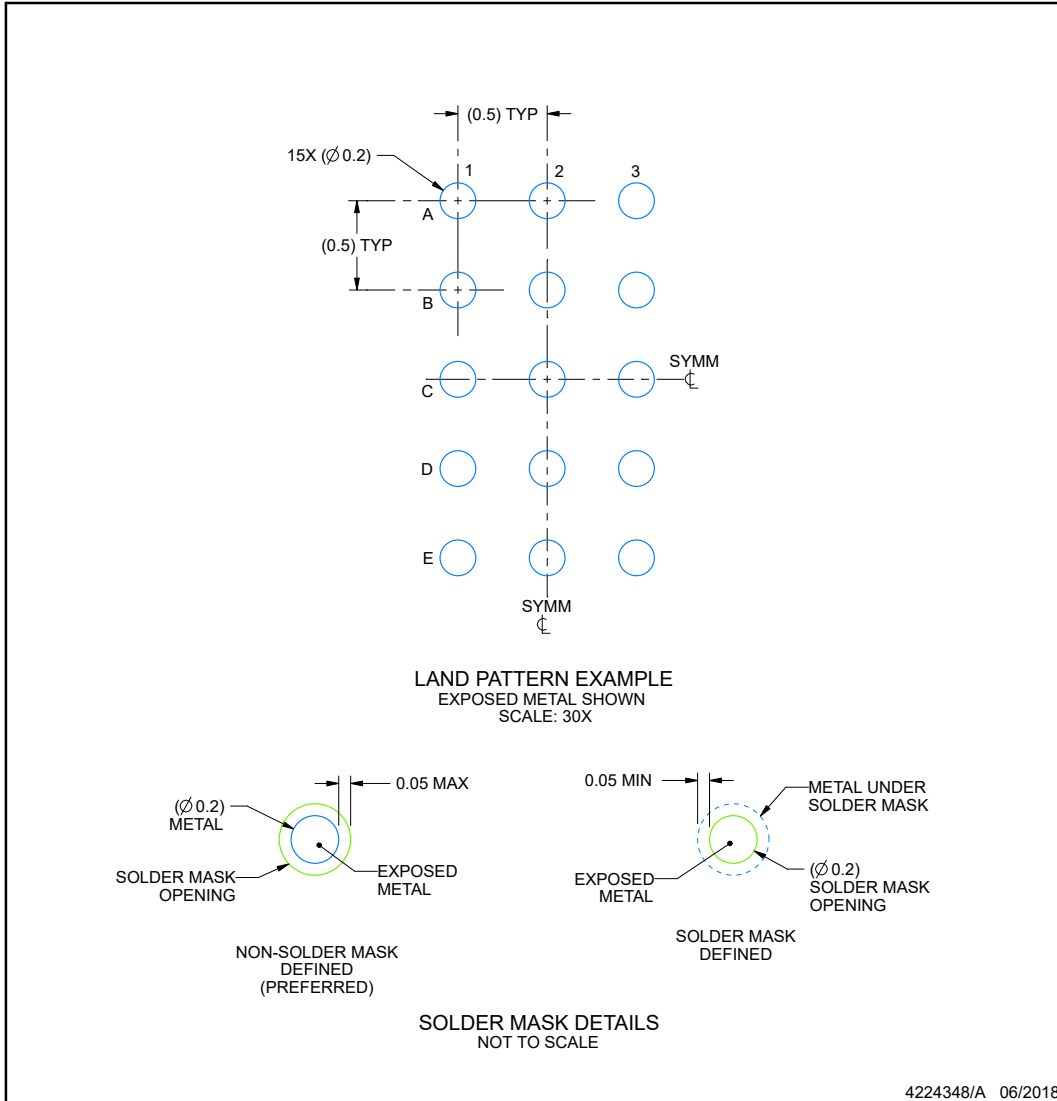

NOTES: (continued)

- Final dimensions may vary due to manufacturing tolerance considerations and also routing constraints. See Texas Instruments Literature No. SNVA009 (www.ti.com/lit/snva009).

EXAMPLE STENCIL DESIGN

YAH0015

DSBGA - 0.4 mm max height

DIE SIZE BALL GRID ARRAY

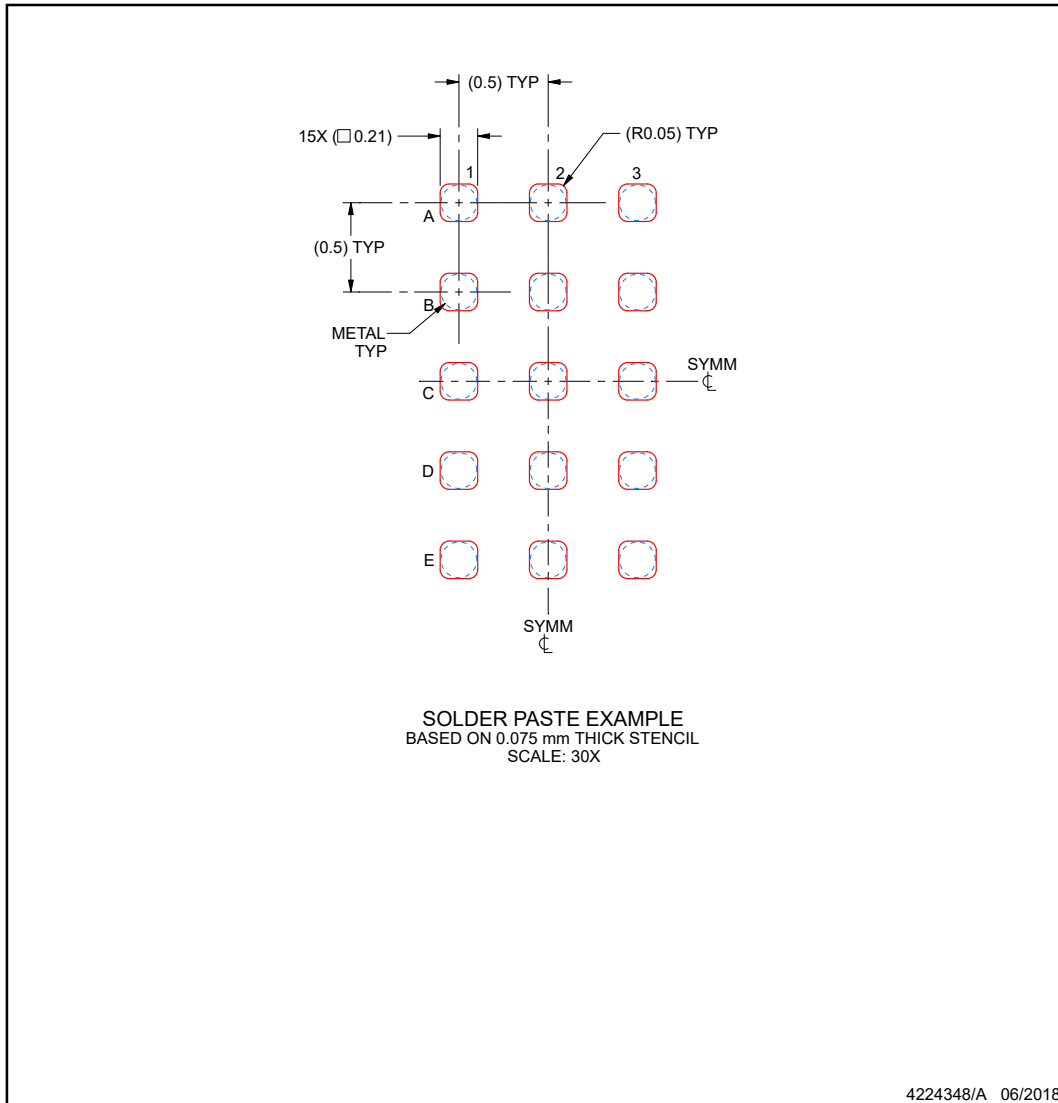

NOTES: (continued)

4. Laser cutting apertures with trapezoidal walls and rounded corners may offer better paste release.

ADVANCE INFORMATION

PACKAGING INFORMATION

Orderable part number	Status (1)	Material type (2)	Package Pins	Package qty Carrier	RoHS (3)	Lead finish/ Ball material (4)	MSL rating/ Peak reflow (5)	Op temp (°C)	Part marking (6)
PQ27Z855Yahr	Active	Preproduction	DSBGA (YAH) 15	3000 LARGE T&R	-	Call TI	Call TI	-40 to 85	

(1) **Status:** For more details on status, see our [product life cycle](#).

(2) **Material type:** When designated, preproduction parts are prototypes/experimental devices, and are not yet approved or released for full production. Testing and final process, including without limitation quality assurance, reliability performance testing, and/or process qualification, may not yet be complete, and this item is subject to further changes or possible discontinuation. If available for ordering, purchases will be subject to an additional waiver at checkout, and are intended for early internal evaluation purposes only. These items are sold without warranties of any kind.

(3) **RoHS values:** Yes, No, RoHS Exempt. See the [TI RoHS Statement](#) for additional information and value definition.

(4) **Lead finish/Ball material:** Parts may have multiple material finish options. Finish options are separated by a vertical ruled line. Lead finish/Ball material values may wrap to two lines if the finish value exceeds the maximum column width.

(5) **MSL rating/Peak reflow:** The moisture sensitivity level ratings and peak solder (reflow) temperatures. In the event that a part has multiple moisture sensitivity ratings, only the lowest level per JEDEC standards is shown. Refer to the shipping label for the actual reflow temperature that will be used to mount the part to the printed circuit board.

(6) **Part marking:** There may be an additional marking, which relates to the logo, the lot trace code information, or the environmental category of the part.

Multiple part markings will be inside parentheses. Only one part marking contained in parentheses and separated by a "-" will appear on a part. If a line is indented then it is a continuation of the previous line and the two combined represent the entire part marking for that device.

Important Information and Disclaimer: The information provided on this page represents TI's knowledge and belief as of the date that it is provided. TI bases its knowledge and belief on information provided by third parties, and makes no representation or warranty as to the accuracy of such information. Efforts are underway to better integrate information from third parties. TI has taken and continues to take reasonable steps to provide representative and accurate information but may not have conducted destructive testing or chemical analysis on incoming materials and chemicals. TI and TI suppliers consider certain information to be proprietary, and thus CAS numbers and other limited information may not be available for release.

In no event shall TI's liability arising out of such information exceed the total purchase price of the TI part(s) at issue in this document sold by TI to Customer on an annual basis.

IMPORTANT NOTICE AND DISCLAIMER

TI PROVIDES TECHNICAL AND RELIABILITY DATA (INCLUDING DATASHEETS), DESIGN RESOURCES (INCLUDING REFERENCE DESIGNS), APPLICATION OR OTHER DESIGN ADVICE, WEB TOOLS, SAFETY INFORMATION, AND OTHER RESOURCES "AS IS" AND WITH ALL FAULTS, AND DISCLAIMS ALL WARRANTIES, EXPRESS AND IMPLIED, INCLUDING WITHOUT LIMITATION ANY IMPLIED WARRANTIES OF MERCHANTABILITY, FITNESS FOR A PARTICULAR PURPOSE OR NON-INFRINGEMENT OF THIRD PARTY INTELLECTUAL PROPERTY RIGHTS.

These resources are intended for skilled developers designing with TI products. You are solely responsible for (1) selecting the appropriate TI products for your application, (2) designing, validating and testing your application, and (3) ensuring your application meets applicable standards, and any other safety, security, regulatory or other requirements.

These resources are subject to change without notice. TI grants you permission to use these resources only for development of an application that uses the TI products described in the resource. Other reproduction and display of these resources is prohibited. No license is granted to any other TI intellectual property right or to any third party intellectual property right. TI disclaims responsibility for, and you fully indemnify TI and its representatives against any claims, damages, costs, losses, and liabilities arising out of your use of these resources.

TI's products are provided subject to [TI's Terms of Sale](#), [TI's General Quality Guidelines](#), or other applicable terms available either on ti.com or provided in conjunction with such TI products. TI's provision of these resources does not expand or otherwise alter TI's applicable warranties or warranty disclaimers for TI products. Unless TI explicitly designates a product as custom or customer-specified, TI products are standard, catalog, general purpose devices.

TI objects to and rejects any additional or different terms you may propose.

Copyright © 2026, Texas Instruments Incorporated

Last updated 10/2025