

CD54ACT161, CD74ACT161 4-BIT SYNCHRONOUS BINARY COUNTERS

SCHS298B – APRIL 2000 – REVISED MARCH 2003

- Inputs Are TTL-Voltage Compatible
- Internal Look-Ahead for Fast Counting
- Carry Output for n-Bit Cascading
- Synchronous Counting
- Synchronously Programmable
- SCR-Latchup-Resistant CMOS Process and Circuit Design
- Exceeds 2-kV ESD Protection per MIL-STD-883, Method 3015

CD54ACT161 . . . F PACKAGE
CD74ACT161 . . . E OR M PACKAGE
(TOP VIEW)

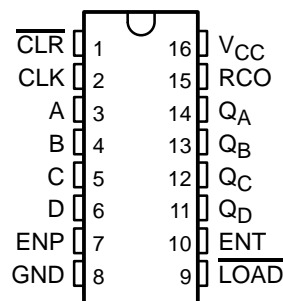

description/ordering information

The 'ACT161 devices are 4-bit binary counters. These synchronous, presettable counters feature an internal carry look-ahead for application in high-speed counting designs. Synchronous operation is provided by having all flip-flops clocked simultaneously so that the outputs change coincident with each other when so instructed by the count-enable (ENP, ENT) inputs and internal gating. This mode of operation eliminates the output counting spikes that normally are associated with synchronous (ripple-clock) counters. A buffered clock (CLK) input triggers the four flip-flops on the rising (positive-going) edge of the clock waveform.

These devices are fully programmable; that is, they can be preset to any number between 0 and 9 or 15. Presetting is synchronous; therefore, setting up a low level at the load input disables the counter and causes the outputs to agree with the setup data after the next clock pulse, regardless of the levels of the enable inputs.

The clear function is asynchronous. A low level at the clear ($\overline{\text{CLR}}$) input sets all four of the flip-flop outputs low, regardless of the levels of the CLK, load ($\overline{\text{LOAD}}$), or enable inputs.

The carry look-ahead circuitry provides for cascading counters for n-bit synchronous applications without additional gating. Instrumental in accomplishing this function are ENP, ENT, and a ripple-carry output (RCO). Both ENP and ENT must be high to count, and ENT is fed forward to enable RCO. Enabling RCO produces a high-level pulse while the count is maximum (9 or 15, with Q_A high). This high-level overflow ripple-carry pulse can be used to enable successive cascaded stages. Transitions at ENP or ENT are allowed, regardless of the level of CLK.

The counters feature a fully independent clock circuit. Changes at control inputs (ENP, ENT, or $\overline{\text{LOAD}}$) that modify the operating mode have no effect on the contents of the counter until clocking occurs. The function of the counter (whether enabled, disabled, loading, or counting) is dictated solely by the conditions meeting the stable setup and hold times.

ORDERING INFORMATION

TA	PACKAGE†		ORDERABLE PART NUMBER	TOP-SIDE MARKING
-55°C to 125°C	PDIP – E	Tube	CD74ACT161E	CD74ACT161E
	SOIC – M	Tube	CD74ACT161M	ACT161M
		Tape and reel	CD74ACT161M96	
	CDIP – F	Tube	CD54ACT161F3A	CD54ACT161F3A



Please be aware that an important notice concerning availability, standard warranty, and use in critical applications of Texas Instruments semiconductor products and disclaimers thereto appears at the end of this data sheet.

PRODUCTION DATA information is current as of publication date. Products conform to specifications per the terms of Texas Instruments standard warranty. Production processing does not necessarily include testing of all parameters.

 **TEXAS
INSTRUMENTS**

POST OFFICE BOX 655303 • DALLAS, TEXAS 75265

Copyright © 2003, Texas Instruments Incorporated
On products compliant to MIL-PRF-38535, all parameters are tested unless otherwise noted. On all other products, production processing does not necessarily include testing of all parameters.

CD54ACT161, CD74ACT161 4-BIT SYNCHRONOUS BINARY COUNTERS

SCHS298B – APRIL 2000 – REVISED MARCH 2003

FUNCTION TABLE

INPUTS						OUTPUTS		FUNCTION
CLR	CLK	ENP	ENT	LOAD	A,B,C,D	Q _n	RCO	
L	X	X	X	X	X	L	L	Reset (clear)
H	↑	X	X	l	l	L	L	Parallel load
H	↑	X	X	l	h	H	Note 1	
H	↑	h	h	h	X	Count	Note 1	Count
H	X	l	X	h	X	q _n	Note 1	Inhibit
H	X	X	l	h	X	q _n	L	

H = high level, L = low level, X = don't care, h = high level one setup time prior to the CLK low-to-high transition, l = low level one setup time prior to the CLK low-to-high transition, q = the state of the referenced output prior to the CLK low-to-high transition, and ↑ = CLK low-to-high transition.

NOTE 1: The RCO output is high when ENT is high and the counter is at terminal count (HHHH).



CD54ACT161, CD74ACT161 4-BIT SYNCHRONOUS BINARY COUNTERS

SCHS298B – APRIL 2000 – REVISED MARCH 2003

logic diagram (positive logic)

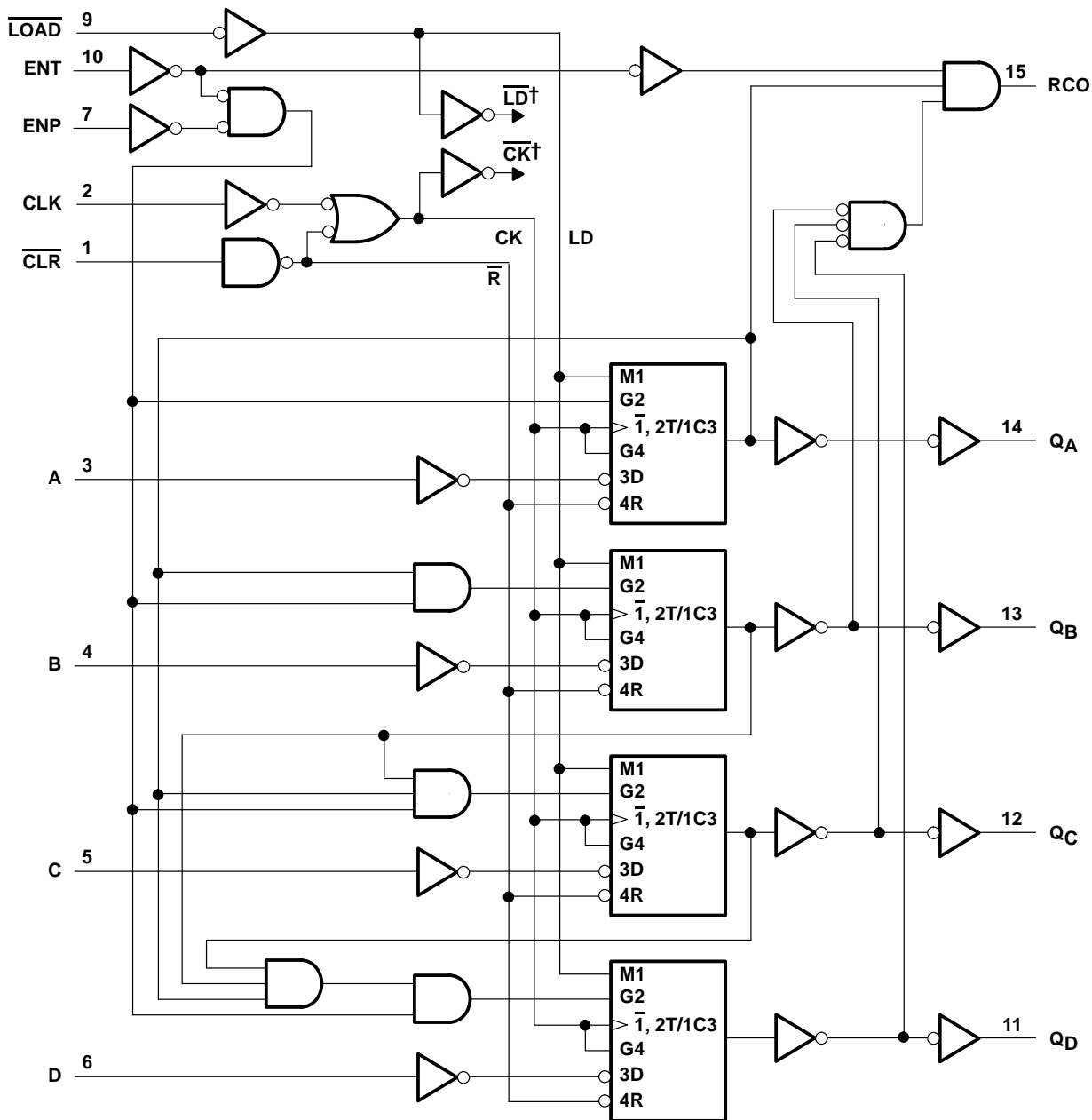

† For simplicity, routing of complementary signals $\overline{\text{LD}}$ and $\overline{\text{CK}}$ is not shown on this overall logic diagram. The uses of these signals are shown on the logic diagram of the D/T flip-flops.

CD54ACT161, CD74ACT161 4-BIT SYNCHRONOUS BINARY COUNTERS

SCHS298B – APRIL 2000 – REVISED MARCH 2003

logic symbol, each D/T flip-flop

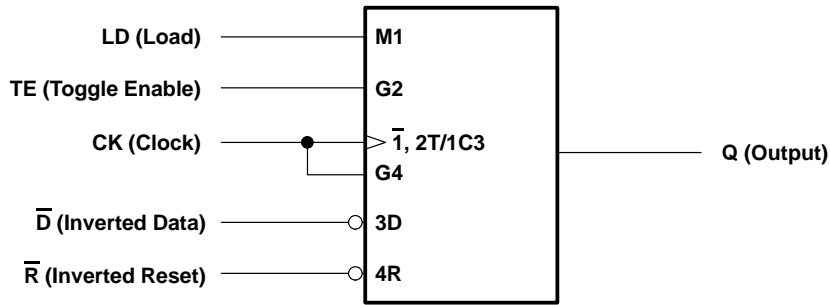

logic diagram, each D/T flip-flop (positive logic)

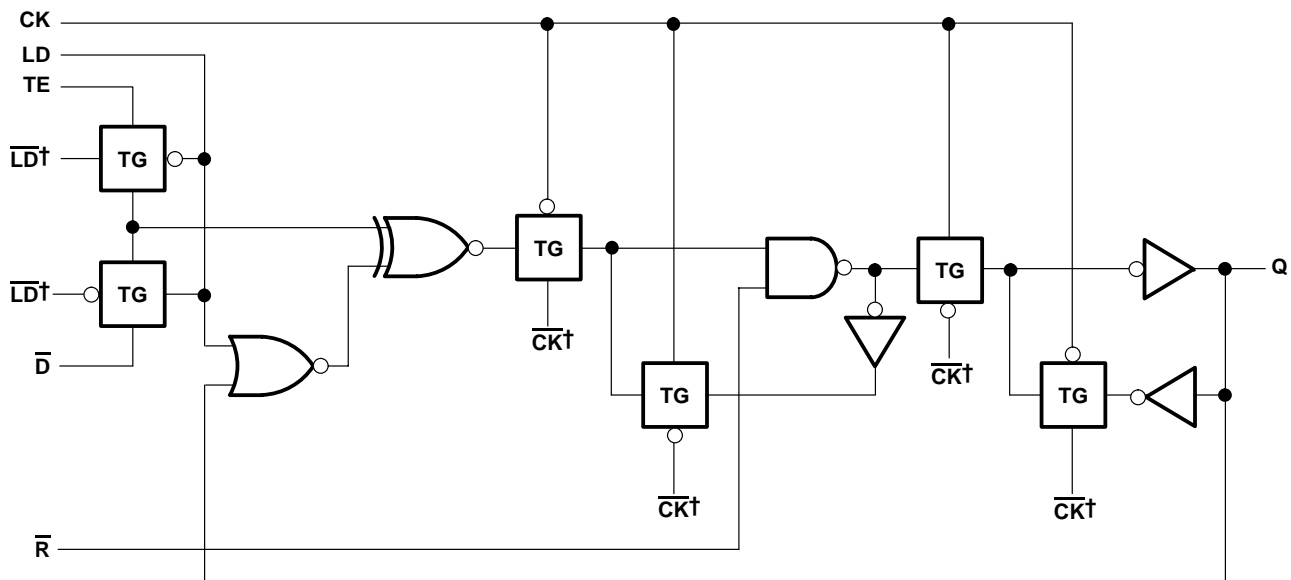

† The origins of \overline{LD} and \overline{CK} are shown in the logic diagram of the overall device.

typical clear, preset, count, and inhibit sequence

The following sequence is illustrated below:

1. Clear outputs to zero (asynchronous)
2. Preset to binary 12
3. Count to 13, 14, 15, 0, 1, and 2
4. Inhibit

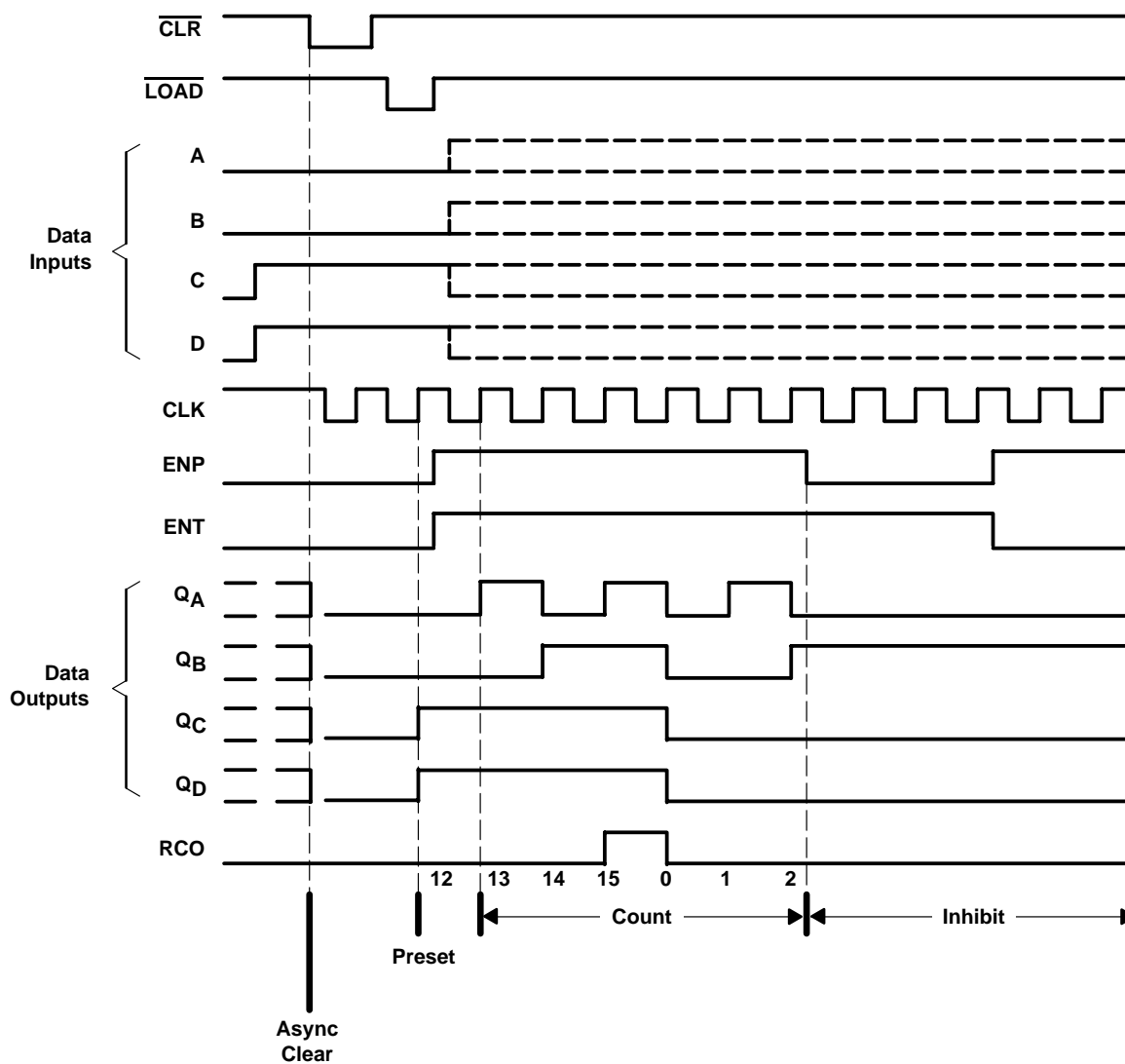

CD54ACT161, CD74ACT161 4-BIT SYNCHRONOUS BINARY COUNTERS

SCHS298B – APRIL 2000 – REVISED MARCH 2003

absolute maximum ratings over operating free-air temperature range (unless otherwise noted)†

Supply voltage range, V_{CC}	-0.5 V to 6 V
Input clamp current, I_{IK} ($V_I < 0$ V or $V_I > V_{CC}$) (see Note 2)	± 20 mA
Output clamp current, I_{OK} ($V_O < 0$ V or $V_O > V_{CC}$) (see Note 2)	± 50 mA
Continuous output current, I_O ($V_O > 0$ V or $V_O < V_{CC}$)	± 50 mA
Continuous current through V_{CC} or GND	± 100 mA
Package thermal impedance, θ_{JA} (see Note 3): E package	67°C/W
M package	73°C/W
Storage temperature range, T_{stg}	-65°C to 150°C

† Stresses beyond those listed under “absolute maximum ratings” may cause permanent damage to the device. These are stress ratings only, and functional operation of the device at these or any other conditions beyond those indicated under “recommended operating conditions” is not implied. Exposure to absolute-maximum-rated conditions for extended periods may affect device reliability.

- NOTES: 2. The input and output voltage ratings may be exceeded if the input and output current ratings are observed.
3. The package thermal impedance is calculated in accordance with JESD 51-7.

recommended operating conditions (see Note 4)

	$T_A = 25^\circ\text{C}$		$-55^\circ\text{C to } 125^\circ\text{C}$		$-40^\circ\text{C to } 85^\circ\text{C}$		UNIT
	MIN	MAX	MIN	MAX	MIN	MAX	
V_{CC} Supply voltage	4.5	5.5	4.5	5.5	4.5	5.5	V
V_{IH} High-level input voltage	2		2		2		V
V_{IL} Low-level input voltage		0.8		0.8		0.8	V
V_I Input voltage	0	V_{CC}	0	V_{CC}	0	V_{CC}	V
V_O Output voltage	0	V_{CC}	0	V_{CC}	0	V_{CC}	V
I_{OH} High-level output current		-24		-24		-24	mA
I_{OL} Low-level output current		24		24		24	mA
$\Delta t/\Delta v$ Input transition rise or fall rate		10		10		10	ns

NOTE 4: All unused inputs of the device must be held at V_{CC} or GND to ensure proper device operation. Refer to the TI application report, *Implications of Slow or Floating CMOS Inputs*, literature number SCBA004.



CD54ACT161, CD74ACT161 4-BIT SYNCHRONOUS BINARY COUNTERS

SCHS298B – APRIL 2000 – REVISED MARCH 2003

electrical characteristics over recommended operating free-air temperature range (unless otherwise noted)

PARAMETER	TEST CONDITIONS	V _{CC}	T _A = 25°C		–55°C to 125°C		–40°C to 85°C		UNIT
			MIN	MAX	MIN	MAX	MIN	MAX	
V _{OH}	V _I = V _{IH} or V _{IL}	I _{OH} = –50 μA	4.5 V	4.4	4.4	4.4			V
		I _{OH} = –24 mA	4.5 V	3.94	3.7	3.8			
		I _{OH} = –50 mA [†]	5.5 V	–	3.85	–			
		I _{OH} = –75 mA [†]	5.5 V				3.85		
V _{OL}	V _I = V _{IH} or V _{IL}	I _{OL} = 50 μA	4.5 V	0.1	0.1	0.1			V
		I _{OL} = 24 mA	4.5 V	0.36	0.5	0.44			
		I _{OL} = 50 mA [†]	5.5 V	–	1.65	–			
		I _{OL} = 75 mA [†]	5.5 V	–	–	1.65			
I _I	V _I = V _{CC} or GND	5.5 V	±0.1	±1	±1			μA	
I _{CC}	V _I = V _{CC} or GND, I _O = 0	5.5 V	8	160	80			μA	
ΔI _{CC} [‡]	V _I = V _{CC} – 2.1 V	4.5 V to 5.5 V	2.4	3	2.8			mA	
C _i			10	10	10			pF	

[†] Test one output at a time, not exceeding 1-second duration. Measurement is made by forcing indicated current and measuring voltage to minimize power dissipation. Test verifies a minimum 50-Ω transmission-line drive capability at 85°C and 75-Ω transmission-line drive capability at 125°C.

[‡] Additional quiescent supply current per input pin, TTL inputs high, 1 unit load

ACT INPUT LOAD TABLE

INPUT	UNIT LOAD
A, B, C, or D	0.13
CLK	1
CLR, ENT	0.83
LOAD	0.67
ENP	0.5

Unit Load is ΔI_{CC} limit specified in electrical characteristics table (e.g., 2.4 mA at 25°C).

timing requirements over recommended operating conditions (unless otherwise noted)

		–55°C to 125°C		–40°C to 85°C		UNIT
		MIN	MAX	MIN	MAX	
f _{clock}	Clock frequency		80		91	MHz
t _w	Pulse duration	CLK high or low	6.2	5.4		ns
		CLR low	6	5.3		
t _{su}	Setup time, before CLK [↑]	A, B, C, or D	5	4.4		ns
		LOAD	6	5.3		
t _h	Hold time, after CLK [↑]	A, B, C, or D	0	0		ns
		ENP or ENT	0	0		
t _{rec}	Recovery time, $\overline{\text{CLR}}$ [↑] before CLK [↑]		6		5.3	ns



CD54ACT161, CD74ACT161 4-BIT SYNCHRONOUS BINARY COUNTERS

SCHS298B – APRIL 2000 – REVISED MARCH 2003

switching characteristics over recommended operating conditions, $C_L = 50$ pF (unless otherwise noted) (see Figure 1)

PARAMETER	FROM (INPUT)	TO (OUTPUT)	-55°C to 125°C		-40°C to 85°C		UNIT
			MIN	MAX	MIN	MAX	
f_{max}			80		91		MHz
t_{pd}	CLK	RCO	4.2	16.7	4.3	15.2	ns
		Any Q	4.1	16.5	4.2	15	
	ENT	RCO	2.7	10.8	2.8	9.8	
	\overline{CLR}	Any Q	4.1	16.5	4.2	15	
		RCO	4.1	16.5	4.2	15	

operating characteristics, $T_A = 25^\circ\text{C}$

PARAMETER	TEST CONDITIONS	TYP	UNIT
C_{pd} Power dissipation capacitance	No load	66	pF



PARAMETER MEASUREMENT INFORMATION

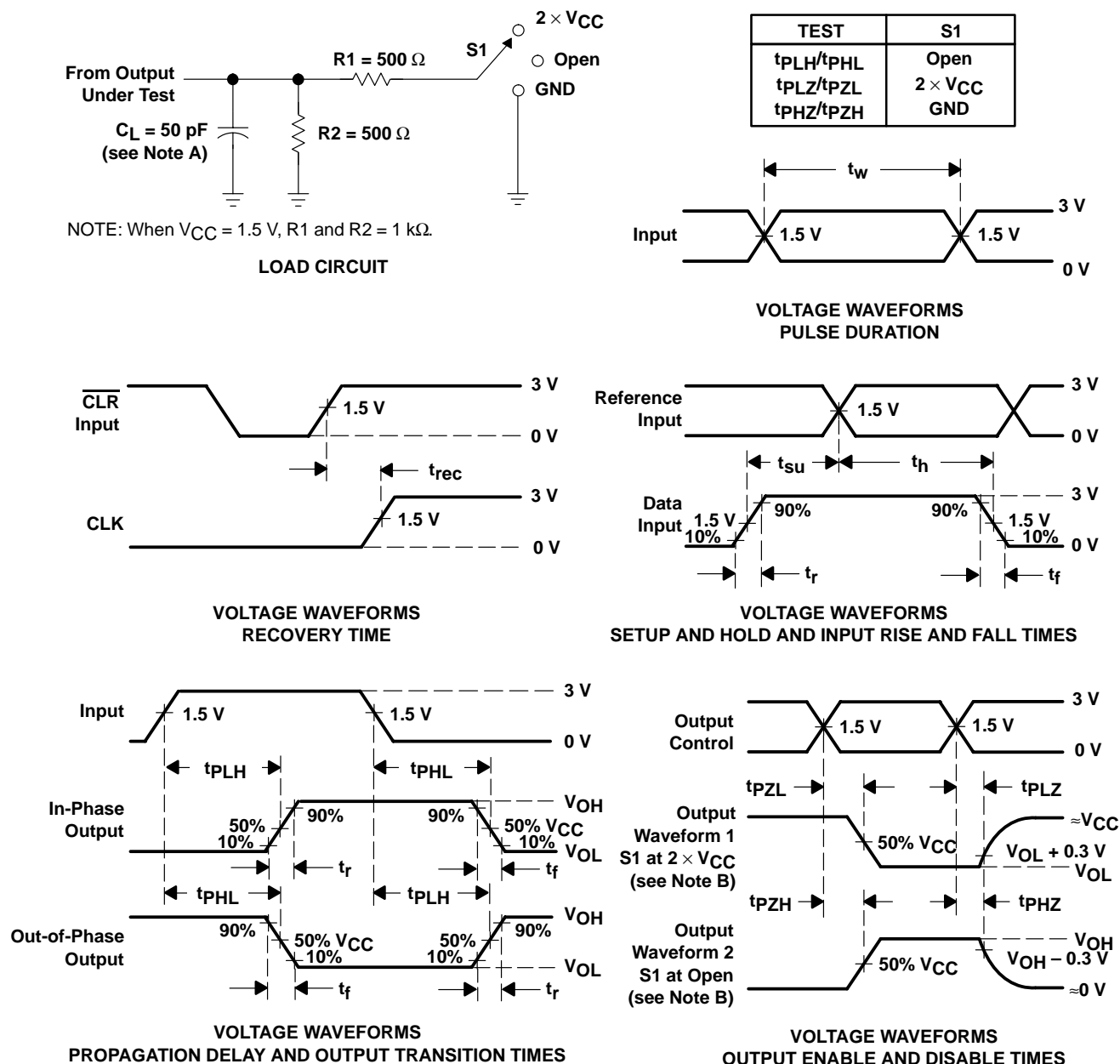

- NOTES:
- A. C_L includes probe and test-fixture capacitance.
 - B. Waveform 1 is for an output with internal conditions such that the output is low except when disabled by the output control. Waveform 2 is for an output with internal conditions such that the output is high except when disabled by the output control.
 - C. All input pulses are supplied by generators having the following characteristics: $PRR \leq 1\text{ MHz}$, $Z_O = 50\ \Omega$, $t_r = 3\text{ ns}$, $t_f = 3\text{ ns}$. Phase relationships between waveforms are arbitrary.
 - D. For clock inputs, f_{max} is measured with the input duty cycle at 50%.
 - E. The outputs are measured one at a time with one input transition per measurement.
 - F. t_{PLH} and t_{PHL} are the same as t_{pd} .
 - G. t_{PZL} and t_{PZH} are the same as t_{en} .
 - H. t_{PLZ} and t_{PHZ} are the same as t_{dis} .
 - I. All parameters and waveforms are not applicable to all devices.

Figure 1. Load Circuit and Voltage Waveforms

PACKAGING INFORMATION

Orderable part number	Status (1)	Material type (2)	Package Pins	Package qty Carrier	RoHS (3)	Lead finish/ Ball material (4)	MSL rating/ Peak reflow (5)	Op temp (°C)	Part marking (6)
CD54ACT161F3A	Active	Production	CDIP (J) 16	25 TUBE	No	SNPB	N/A for Pkg Type	-55 to 125	CD54ACT161F3A
CD54ACT161F3A.A	Active	Production	CDIP (J) 16	25 TUBE	No	SNPB	N/A for Pkg Type	-55 to 125	CD54ACT161F3A
CD74ACT161E	NRND	Production	PDIP (N) 16	25 TUBE	Yes	NIPDAU	N/A for Pkg Type	-55 to 125	CD74ACT161E
CD74ACT161E.A	NRND	Production	PDIP (N) 16	25 TUBE	Yes	NIPDAU	N/A for Pkg Type	-55 to 125	CD74ACT161E
CD74ACT161M	Obsolete	Production	SOIC (D) 16	-	-	Call TI	Call TI	-55 to 125	ACT161M
CD74ACT161M96	Active	Production	SOIC (D) 16	2500 LARGE T&R	Yes	NIPDAU	Level-1-260C-UNLIM	-55 to 125	ACT161M
CD74ACT161M96.A	Active	Production	SOIC (D) 16	2500 LARGE T&R	Yes	NIPDAU	Level-1-260C-UNLIM	-55 to 125	ACT161M

(1) **Status:** For more details on status, see our [product life cycle](#).

(2) **Material type:** When designated, preproduction parts are prototypes/experimental devices, and are not yet approved or released for full production. Testing and final process, including without limitation quality assurance, reliability performance testing, and/or process qualification, may not yet be complete, and this item is subject to further changes or possible discontinuation. If available for ordering, purchases will be subject to an additional waiver at checkout, and are intended for early internal evaluation purposes only. These items are sold without warranties of any kind.

(3) **RoHS values:** Yes, No, RoHS Exempt. See the [TI RoHS Statement](#) for additional information and value definition.

(4) **Lead finish/Ball material:** Parts may have multiple material finish options. Finish options are separated by a vertical ruled line. Lead finish/Ball material values may wrap to two lines if the finish value exceeds the maximum column width.

(5) **MSL rating/Peak reflow:** The moisture sensitivity level ratings and peak solder (reflow) temperatures. In the event that a part has multiple moisture sensitivity ratings, only the lowest level per JEDEC standards is shown. Refer to the shipping label for the actual reflow temperature that will be used to mount the part to the printed circuit board.

(6) **Part marking:** There may be an additional marking, which relates to the logo, the lot trace code information, or the environmental category of the part.

Multiple part markings will be inside parentheses. Only one part marking contained in parentheses and separated by a "-" will appear on a part. If a line is indented then it is a continuation of the previous line and the two combined represent the entire part marking for that device.

Important Information and Disclaimer: The information provided on this page represents TI's knowledge and belief as of the date that it is provided. TI bases its knowledge and belief on information provided by third parties, and makes no representation or warranty as to the accuracy of such information. Efforts are underway to better integrate information from third parties. TI has taken and continues to take reasonable steps to provide representative and accurate information but may not have conducted destructive testing or chemical analysis on incoming materials and chemicals. TI and TI suppliers consider certain information to be proprietary, and thus CAS numbers and other limited information may not be available for release.

In no event shall TI's liability arising out of such information exceed the total purchase price of the TI part(s) at issue in this document sold by TI to Customer on an annual basis.

OTHER QUALIFIED VERSIONS OF CD54ACT161, CD74ACT161 :

- Catalog : [CD74ACT161](#)
- Military : [CD54ACT161](#)

NOTE: Qualified Version Definitions:

- Catalog - TI's standard catalog product
- Military - QML certified for Military and Defense Applications

TAPE AND REEL INFORMATION

QUADRANT ASSIGNMENTS FOR PIN 1 ORIENTATION IN TAPE

*All dimensions are nominal

Device	Package Type	Package Drawing	Pins	SPQ	Reel Diameter (mm)	Reel Width W1 (mm)	A0 (mm)	B0 (mm)	K0 (mm)	P1 (mm)	W (mm)	Pin1 Quadrant
CD74ACT161M96	SOIC	D	16	2500	330.0	16.4	6.5	10.3	2.1	8.0	16.0	Q1

TAPE AND REEL BOX DIMENSIONS

*All dimensions are nominal

Device	Package Type	Package Drawing	Pins	SPQ	Length (mm)	Width (mm)	Height (mm)
CD74ACT161M96	SOIC	D	16	2500	340.5	336.1	32.0

TUBE

*All dimensions are nominal

Device	Package Name	Package Type	Pins	SPQ	L (mm)	W (mm)	T (μm)	B (mm)
CD74ACT161E	N	PDIP	16	25	506	13.97	11230	4.32
CD74ACT161E	N	PDIP	16	25	506	13.97	11230	4.32
CD74ACT161E.A	N	PDIP	16	25	506	13.97	11230	4.32
CD74ACT161E.A	N	PDIP	16	25	506	13.97	11230	4.32

D (R-PDSO-G16)

PLASTIC SMALL OUTLINE



4040047-6/M 06/11

- NOTES:
- A. All linear dimensions are in inches (millimeters).
 - B. This drawing is subject to change without notice.
 -  C. Body length does not include mold flash, protrusions, or gate burrs. Mold flash, protrusions, or gate burrs shall not exceed 0.006 (0,15) each side.
 -  D. Body width does not include interlead flash. Interlead flash shall not exceed 0.017 (0,43) each side.
 - E. Reference JEDEC MS-012 variation AC.

J (R-GDIP-T**)

14 LEADS SHOWN

CERAMIC DUAL IN-LINE PACKAGE



DIM \ PINS **	14	16	18	20
A	0.300 (7,62) BSC	0.300 (7,62) BSC	0.300 (7,62) BSC	0.300 (7,62) BSC
B MAX	0.785 (19,94)	.840 (21,34)	0.960 (24,38)	1.060 (26,92)
B MIN	—	—	—	—
C MAX	0.300 (7,62)	0.300 (7,62)	0.310 (7,87)	0.300 (7,62)
C MIN	0.245 (6,22)	0.245 (6,22)	0.220 (5,59)	0.245 (6,22)



4040083/F 03/03

- NOTES:
- All linear dimensions are in inches (millimeters).
 - This drawing is subject to change without notice.
 - This package is hermetically sealed with a ceramic lid using glass frit.
 - Index point is provided on cap for terminal identification only on press ceramic glass frit seal only.
 - Falls within MIL STD 1835 GDIP1-T14, GDIP1-T16, GDIP1-T18 and GDIP1-T20.

N (R-PDIP-T**)

PLASTIC DUAL-IN-LINE PACKAGE

16 PINS SHOWN



- NOTES:
- A. All linear dimensions are in inches (millimeters).
 - B. This drawing is subject to change without notice.
 - $\triangle C$ Falls within JEDEC MS-001, except 18 and 20 pin minimum body length (Dim A).
 - $\triangle D$ The 20 pin end lead shoulder width is a vendor option, either half or full width.

IMPORTANT NOTICE AND DISCLAIMER

TI PROVIDES TECHNICAL AND RELIABILITY DATA (INCLUDING DATASHEETS), DESIGN RESOURCES (INCLUDING REFERENCE DESIGNS), APPLICATION OR OTHER DESIGN ADVICE, WEB TOOLS, SAFETY INFORMATION, AND OTHER RESOURCES "AS IS" AND WITH ALL FAULTS, AND DISCLAIMS ALL WARRANTIES, EXPRESS AND IMPLIED, INCLUDING WITHOUT LIMITATION ANY IMPLIED WARRANTIES OF MERCHANTABILITY, FITNESS FOR A PARTICULAR PURPOSE OR NON-INFRINGEMENT OF THIRD PARTY INTELLECTUAL PROPERTY RIGHTS.

These resources are intended for skilled developers designing with TI products. You are solely responsible for (1) selecting the appropriate TI products for your application, (2) designing, validating and testing your application, and (3) ensuring your application meets applicable standards, and any other safety, security, regulatory or other requirements.

These resources are subject to change without notice. TI grants you permission to use these resources only for development of an application that uses the TI products described in the resource. Other reproduction and display of these resources is prohibited. No license is granted to any other TI intellectual property right or to any third party intellectual property right. TI disclaims responsibility for, and you fully indemnify TI and its representatives against any claims, damages, costs, losses, and liabilities arising out of your use of these resources.

TI's products are provided subject to [TI's Terms of Sale](#), [TI's General Quality Guidelines](#), or other applicable terms available either on [ti.com](#) or provided in conjunction with such TI products. TI's provision of these resources does not expand or otherwise alter TI's applicable warranties or warranty disclaimers for TI products. Unless TI explicitly designates a product as custom or customer-specified, TI products are standard, catalog, general purpose devices.

TI objects to and rejects any additional or different terms you may propose.

Copyright © 2026, Texas Instruments Incorporated

Last updated 10/2025