

CD74HCT4051-Q1 Automotive High-Speed CMOS Logic

Analog Multiplexers and Demultiplexers

1 Features

- Wide analog input voltage range: $\pm 5V$ maximum
- Low ON-resistance:
 - 70 Ω typical ($V_{CC} - V_{EE} = 4.5V$)
 - 40 Ω typical ($V_{CC} - V_{EE} = 9V$)
- Low crosstalk between switches
- Fast switching and propagation speeds
- Break-before-make switching
- Wide operating temperature range: $-40^{\circ}C$ to $+125^{\circ}C$
- Operation control voltage: 4.5V to 5.5V
- Switch voltage: 0V to 10V
- Direct LSTTL input logic compatibility
 $V_{IL} = 0.8V$ maximum, $V_{IH} = 2V$ minimum
- CMOS input compatibility
 $I_I \leq 1\mu A$ at V_{OL} , V_{OH}

2 Applications

- [Digital radio](#)
- [Signal gating](#)
- [Factory automation](#)
- [Televisions](#)
- [Appliances](#)
- [Programmable logic circuits](#)
- [Sensors](#)

3 Description

The CD74HCT4051-Q1 device is a digitally controlled analog switch that uses silicon gate CMOS technology to achieve operating speeds similar to LSTTL with the low-power consumption of standard CMOS integrated circuits.

This analog multiplexer and demultiplexer controls analog voltages that may vary across the voltage supply range (for example, V_{CC} to V_{EE}). It is a bidirectional switch that allows any analog input to be used as an output and vice versa. The switch has low ON resistance and low OFF leakages. In addition, this device has an enable control that, when high, disables all switches to their OFF state.

Package Information

PART NUMBER	PACKAGE ⁽¹⁾	PACKAGE SIZE ⁽²⁾
CD74HCT4051-Q1	D (SOIC, 16)	9.9mm × 3.9mm

(1) For more information, see [Section 9](#).

(2) The package size (length × width) is a nominal value and includes pins, where applicable.



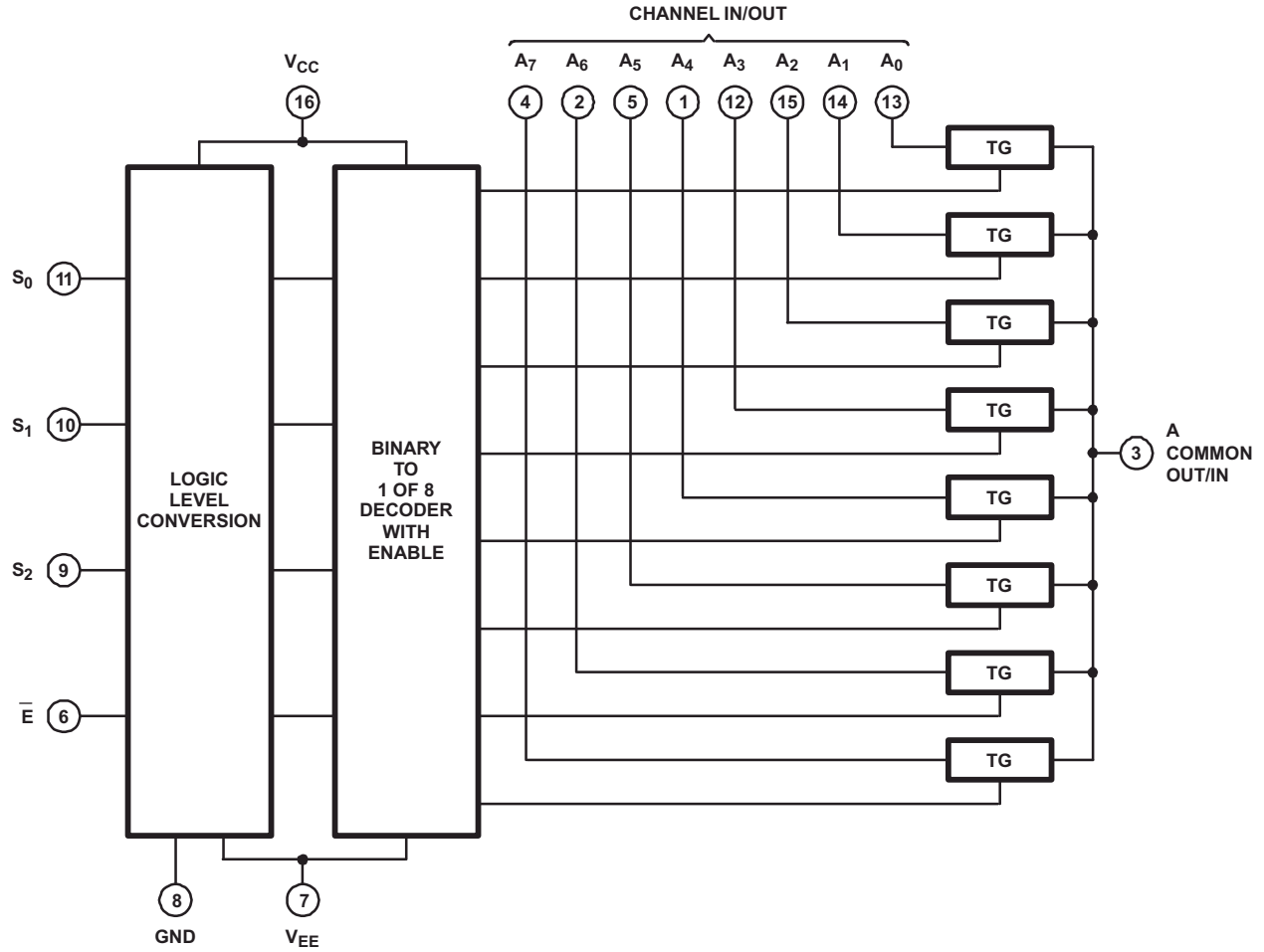

Functional Diagram of HCT4051

Table of Contents

1 Features	1	6 Parameter Measurement Information	8
2 Applications	1	7 Device and Documentation Support	11
3 Description	1	7.1 Documentation Support.....	11
4 Pin Configuration and Functions	3	7.2 Receiving Notification of Documentation Updates....	11
5 Specifications	4	7.3 Support Resources.....	11
5.1 Absolute Maximum Ratings.....	4	7.4 Trademarks.....	11
5.2 Recommended Operating Conditions.....	4	7.5 Electrostatic Discharge Caution.....	11
5.3 Electrical Characteristics: HCT Devices.....	5	7.6 Glossary.....	11
5.4 Switching Characteristics.....	5	8 Revision History	11
5.5 Analog Channel Specifications.....	6	9 Mechanical, Packaging, and Orderable Information..	11
5.6 Typical Characteristics.....	7		

4 Pin Configuration and Functions

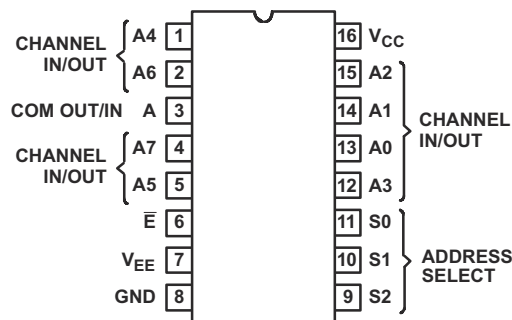

Figure 4-1. D Package, 16-Pin SOIC (Top View)

INPUTS				ON CHANNELS
ENABLE	S2	S1	S0	
L	L	L	L	A0
L	L	L	H	A1
L	L	H	L	A2
L	L	H	H	A3
L	H	L	L	A4
L	H	L	H	A5
L	H	H	L	A6
L	H	H	H	A7
H	X	X	X	None

5 Specifications

5.1 Absolute Maximum Ratings

over operating free-air temperature range (unless otherwise noted)^{(1) (2)}

			MIN	MAX	UNIT
$V_{CC} - V_{EE}$ ⁽²⁾			-0.5	10.5	V
V_{CC}	DC Supply voltage		-0.5	7	V
V_{EE}			0.5	-7	V
I_{IK}	DC input diode current	$V_I < -0.5V$ or $V_I > V_{CC} + 0.5V$	-20	20	mA
I_{OK}	DC switch diode current	$V_I < V_{EE} - 0.5V$ or $V_I > V_{CC} + 0.5V$	-20	20	mA
	DC switch current	$V_I < V_{EE} - 0.5V$ or $V_I > V_{CC} + 0.5V$	-25	25	mA
I_{CC}	DC V_{CC} or ground current		-50	50	mA
I_{EE}	DC V_{EE} current		-20		mA
$R_{\theta JA}$	Package thermal impedance ⁽³⁾			91.6	°C/W
T_{JMAX}	Maximum junction temperature			150	°C
T_{LMAX}	Maximum lead temperature	Soldering 10 s		300	°C
T_{stg}	Storage temperature		-65	150	°C

- (1) Stresses beyond those listed under *Absolute Maximum Rating* may cause permanent damage to the device. These are stress ratings only, which do not imply functional operation of the device at these or any other conditions beyond those indicated under *Recommended Operating Condition*. Exposure to absolute-maximum-rated conditions for extended periods may affect device reliability.
- (2) All voltages are with respect to ground, unless otherwise specified.
- (3) The package thermal impedance is calculated in accordance with JESD 51-7

5.2 Recommended Operating Conditions

over operating free-air temperature range (unless otherwise noted)⁽¹⁾

			MIN	NOM	MAX	UNIT
V_{CC}	Supply voltage range (T_A = full package temperature range) ⁽²⁾		4.5		5.5	V
$V_{CC} - V_{EE}$	Supply voltage range (T_A = full package temperature range) ⁽²⁾		2		10	V
V_{EE} ⁽²⁾	Supply voltage range (T_A = full package temperature range) ⁽³⁾		0		-6	V
V_{IH}	High-level input voltage		2			V
V_{IL}	Low-level input voltage				0.8	V
V_I	DC input control voltage		0		V_{CC}	V
V_{IS}	Analog switch I/O voltage		V_{EE}		V_{CC}	V
t_r, t_f	Input rise and fall times	$V_{CC} = 4.5V$	0		500	ns
T_A	Ambient temperature		-40		125	°C

- (1) All unused inputs of the device must be held at V_{CC} or GND to ensure proper device operation. Refer to the TI application report, *Implications of Slow or Floating CMOS Inputs*, Literature number SCBA004.
- (2) In certain applications, the external load resistor current may include both V_{CC} and signal-line components. To avoid drawing V_{CC} current when switch current flows into the transmission gate inputs, the voltage drop across the bidirectional switch must not exceed 0.6V (calculated from r_{on} values shown in electrical characteristics tables). No V_{CC} current flows through R_L if the switch current flows into the COM OUT/IN A terminal.

5.3 Electrical Characteristics: HCT Devices

Over operating free-air temperature range, $V_{SUPPLY} = \pm 5V$, and $R_L = 100\Omega$, (unless otherwise noted)⁽¹⁾

PARAMETER	TEST CONDITIONS				MIN	TYP	MAX	UNIT
CD74HCT4051-Q1								
r_{ON} ON resistance	$I_O = 1mA$ $V_I = V_{IH}$ or V_{IL}	$V_{IS} = V_{CC}$ or V_{EE}	0	4.5	25°C	70	160	Ω
					-40°C to +125°C	240		
			-4.5	4.5	25°C	40	120	
		$V_{IS} = V_{CC}$ to V_{EE}	0	4.5	25°C	90	180	
					-40°C to +125°C	270		
			-4.5	4.5	25°C	45	130	
Δr_{ON} Maximum ON resistance between any two channels	Between any two channels		0	4.5	25°C	10		Ω
			-4.5	4.5	25°C	5		
I_{IZ} Switch ON/OFF leakage current	For switch OFF: When $V_{IS} = V_{CC}$, $V_{OS} = V_{EE}$; When $V_{IS} = V_{EE}$, $V_{OS} = V_{CC}$, For switch ON: All applicable combinations of V_{IS} and V_{OS} voltage levels $V_I = V_{IH}$ or V_{IL}		0	6	25°C	± 0.2		μA
					-40°C to 125°C		± 2	
-5			5	25°C	± 0.4			
				-40°C to 125°C		± 4		
I_{IL} Control input leakage current	$V_I = V_{CC}$ or GND			5.5	25°C	± 0.1		μA
					-40°C to 125°C		± 1	
Quiescent Device Current, I_{CC} Max	$I_O = 0$ $V_{IS} = V_{CC}$ or GND	When $V_{IS} = V_{EE}$, $V_{OS} = V_{CC}$	0	6	25°C	12		μA
					-40°C to 125°C		160	
		When $V_{IS} = V_{CC}$, $V_{OS} = V_{EE}$	-5	5	25°C	32		
					-40°C to 125°C		320	
Quiescent Device Current, ΔI_{CC} Max ⁽¹⁾	Per input pin: 1 unit load, $V_{IN} = V_{CC} - 2.1V$			4.5V to 5.5V	25°C	100	360	μA
					-40°C to 125°C		490	

(1) For dual-supply systems, theoretical worst case ($V_I = 2.4V$, $V_{CC} = 5.5V$) specification is 1.8mA.

5.4 Switching Characteristics

over operating free-air temperature range (unless otherwise noted)

Parameter	Test Conditions			MIN	NOM	MAX	UNIT
t_{PD}	Switch IN to OUT	$C_L = 15pF$	$V_{CC} = 5V$	25°C	4		ns
			$C_L = 50pF$	$V_{CC} = 4.5V$	25°C	12	
		-40°C to +125°C			18		
		$V_{CC} = 4.5V$, $V_{EE} = -4.5V$		25°C	8		ns
				-40°C to +125°C		12	

5.4 Switching Characteristics (continued)

over operating free-air temperature range (unless otherwise noted)

Parameter		Test Conditions			MIN	NOM	MAX	UNIT
t_{en}	ADDRESS SEL or \bar{E} to OUT	$C_L = 15\text{pF}$	$V_{CC} = 5\text{V}$	25°C	23		ns	
				25°C	55		ns	
		$C_L = 50\text{pF}$	$V_{CC} = 4.5\text{V}$	-40°C to +125°C	83		ns	
				25°C	48		ns	
t_{dis}	ADDRESS SEL or \bar{E} to OUT	$C_L = 15\text{pF}$	$V_{CC} = 5\text{V}$	25°C	35		ns	
				25°C	50		ns	
		$C_L = 50\text{pF}$	$V_{CC} = 4.5\text{V}$	-40°C to +125°C	68		ns	
				25°C	44		ns	
$C_L = 50\text{pF}$	$V_{CC} = 4.5\text{V}, V_{EE} = -4.5\text{V}$	-40°C to +125°C	55		ns			
		-40°C to +125°C	10		pF			
C_i	Control							
C_{PD}	Power dissipation capacitance ⁽¹⁾				52		pF	

(1) Cpd is used to determine the dynamic power consumption, per package.

$$PD = C_{pd} V_{CC2} f_I + \sum (C_L + C_S) V_{CC2} f_O$$

f_O = output frequency

f_I = input frequency

C_L = output load capacitance

C_S = switch capacitance

V_{CC} = supply voltage

5.5 Analog Channel Specifications

over operating free-air temperature range (unless otherwise noted)

Parameter	Test Conditions	V_{EE} (V)	V_{CC} (V)	MIN	NOM	MAX	UNIT
C_i Switch input capacitance				5			pF
C_{COM} Common output capacitance				25			pF
f_{MAX} ⁽²⁾ Minimum switch frequency response at -3 dB ⁽¹⁾		-2.25	2.25	145			MHz
		-4.5	4.5	180			
THD Sine-wave distortion		-2.25	2.25	0.035			%
		-4.5	4.5	0.018			
Switch OFF signal ⁽²⁾ feedthrough ⁽³⁾		-2.25	2.25	-73			dB
		-4.5	4.5	-75			

(1) Adjust input voltage to obtain 0 dBm at VOS for f_{IN} = 1 MHz.

(2) VIS is centered at $(V_{CC} - V_{EE})/2$.

(3) Adjust input for 0 dBm.

5.6 Typical Characteristics

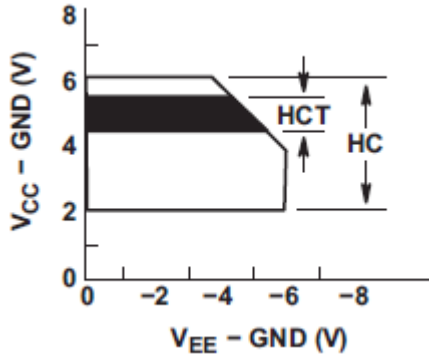

Figure 5-1. Recommended Operating Area as a Function of ($V_{CC} - V_{EE}$)

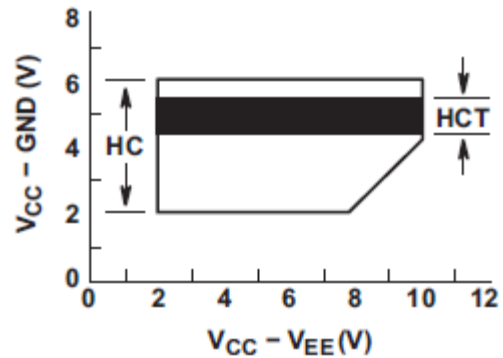

Figure 5-2. Recommended Operating Area as a Function of ($V_{CC} - GND$)

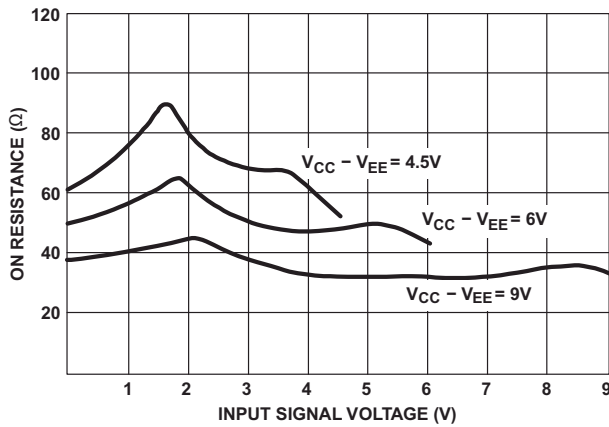

Figure 5-3. Typical ON Resistance vs Input Signal Voltage

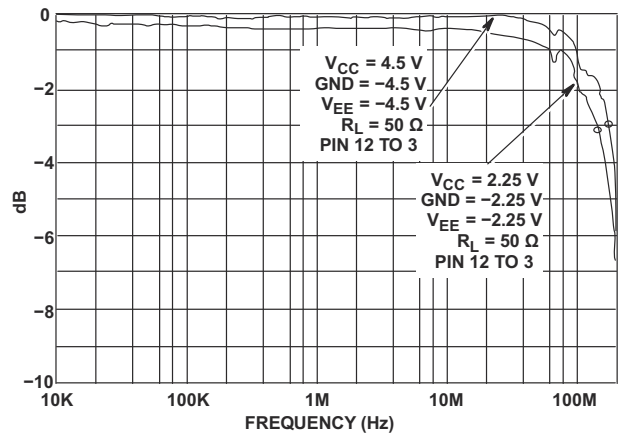

Figure 5-4. Channel ON Bandwidth (HC and HCT4051)

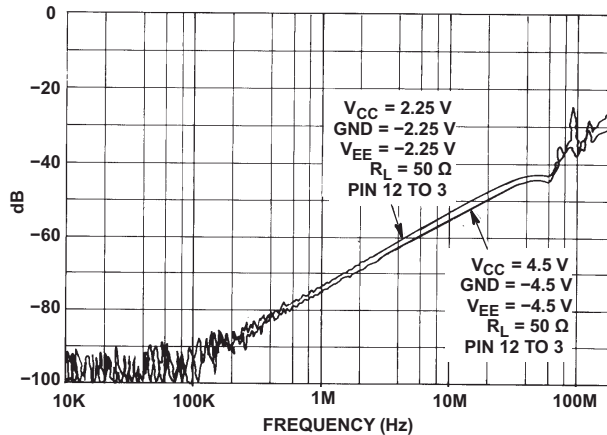
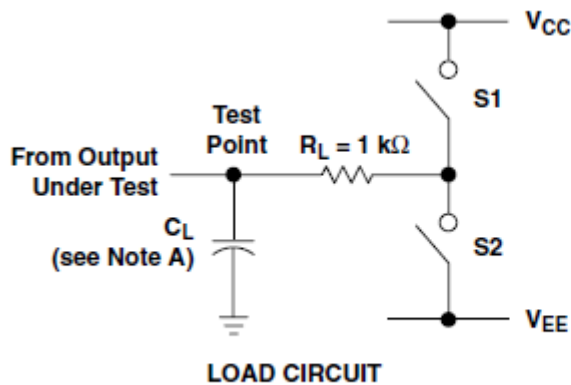

Figure 5-5. Channel OFF Feedthrough (HC and HCT4051)

6 Parameter Measurement Information



PARAMETER		S1	S2
t_{en}	t_{PZH}	Open	Closed
	t_{PZL}	Closed	Open
t_{dis}	t_{PHZ}	Open	Closed
	t_{PLZ}	Closed	Open
t_{pd}		Open	Open

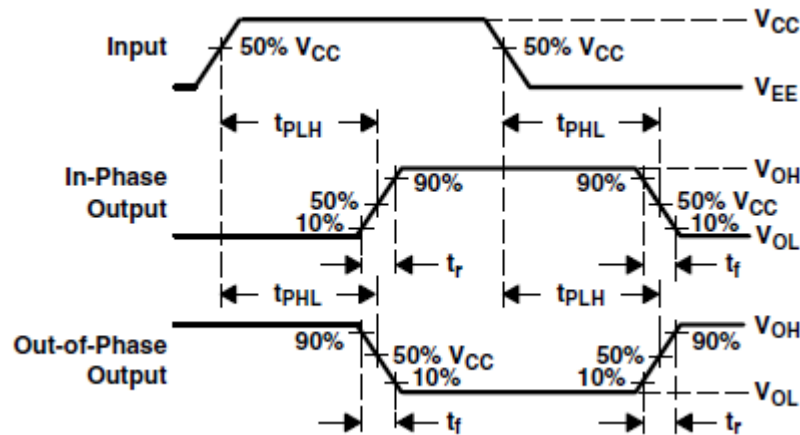

Figure 6-1. Propagation delay and output transition times. Waveform 1

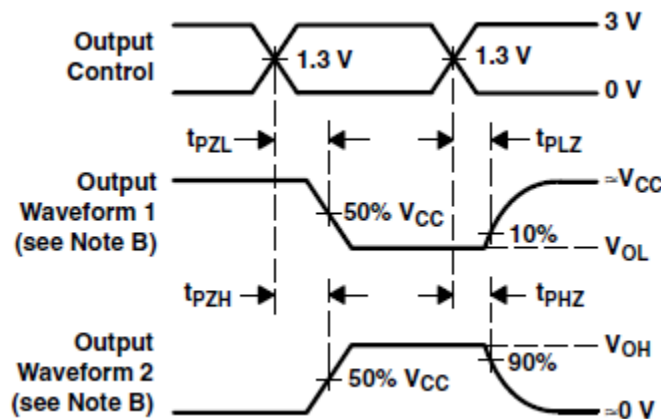

Figure 6-2. Output enable and disable times. Waveform 2

- A. C_L includes probe and test-fixture capacitance.
- B. Waveform 1 is for an output with internal conditions such that the output is low, except when disabled by the output control.

Waveform 2 is for an output with internal conditions such that the output is high, except when disabled by the output control.

- C. Phase relationships between waveforms were chosen arbitrarily. All input pulses are supplied by generators having the following characteristics: $PRR \leq 1\text{MHz}$, $Z_O = 50\Omega$, $t_r = 6\text{ns}$, $t_f = 6\text{ns}$.
- D. For clock inputs, f_{MAX} is measured with the input duty cycle at 50%.
- E. The outputs are measured one at a time, with one input transition per measurement.
- F. t_{PLZ} and t_{PHZ} are the same as t_{dis} .
- G. t_{PZL} AND t_{PZH} are the same as t_{en} .
- H. t_{PLH} and t_{PHL} are the same as t_{pd} .

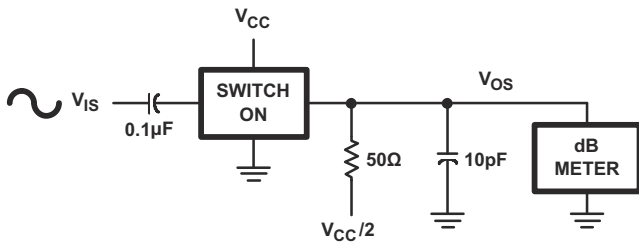

Figure 6-3. Frequency Response Test Circuit

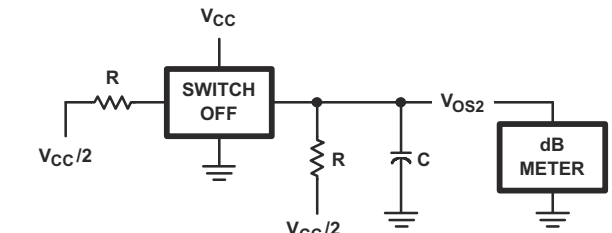
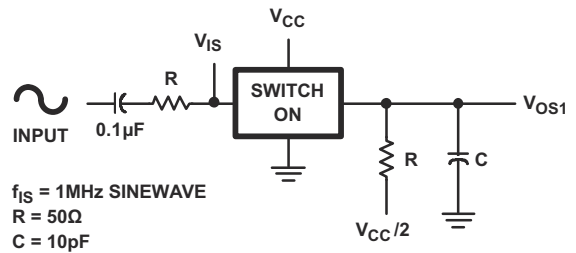

Figure 6-4. Crosstalk Between Two Switches Test Circuit

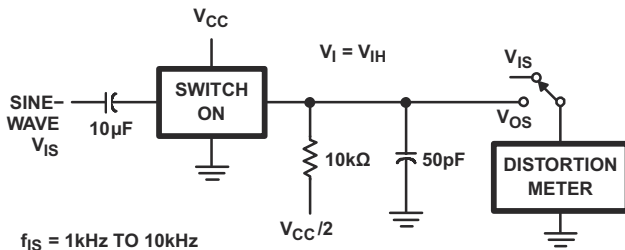

Figure 6-5. 1/4 Sine-Wave Distortion Test Circuit

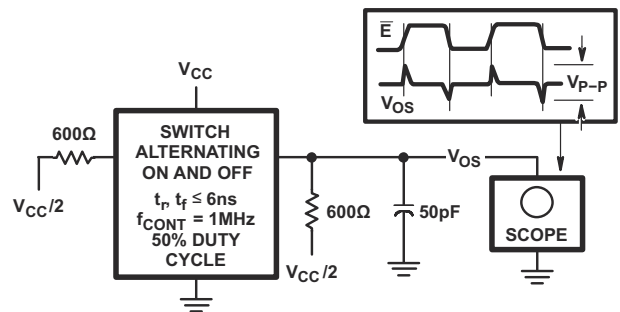

Figure 6-6. Control to Switch Feedthrough Noise Test Circuit

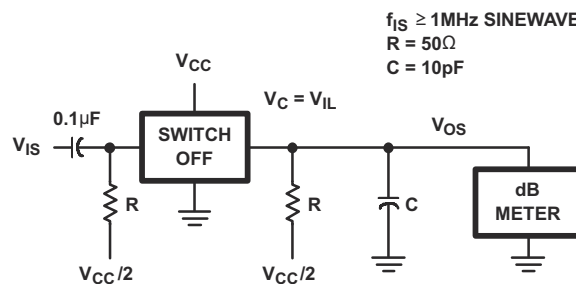

Figure 6-7. Switch OFF Signal Feedthrough

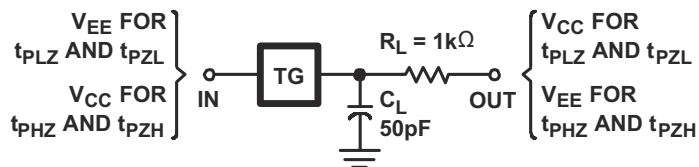

Figure 6-8. Switch ON/OFF Propagation Delay Test Circuit

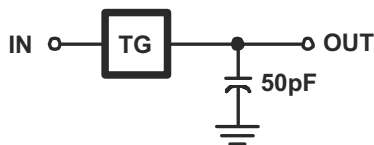

Figure 6-9. Switch In to Switch Out Propagation Delay Test Circuit

7 Device and Documentation Support

7.1 Documentation Support

7.1.1 Related Documentation

For related documentation, see the following:

- Texas Instruments, [Implications of Slow or Floating CMOS Inputs](#)

7.2 Receiving Notification of Documentation Updates

To receive notification of documentation updates, navigate to the device product folder on ti.com. Click on *Notifications* to register and receive a weekly digest of any product information that has changed. For change details, review the revision history included in any revised document.

7.3 Support Resources

[TI E2E™ support forums](#) are an engineer's go-to source for fast, verified answers and design help — straight from the experts. Search existing answers or ask your own question to get the quick design help you need.

Linked content is provided "AS IS" by the respective contributors. They do not constitute TI specifications and do not necessarily reflect TI's views; see TI's [Terms of Use](#).

7.4 Trademarks

TI E2E™ is a trademark of Texas Instruments.
All trademarks are the property of their respective owners.

7.5 Electrostatic Discharge Caution



This integrated circuit can be damaged by ESD. Texas Instruments recommends that all integrated circuits be handled with appropriate precautions. Failure to observe proper handling and installation procedures can cause damage.

ESD damage can range from subtle performance degradation to complete device failure. Precision integrated circuits may be more susceptible to damage because very small parametric changes could cause the device not to meet its published specifications.

7.6 Glossary

[TI Glossary](#) This glossary lists and explains terms, acronyms, and definitions.

8 Revision History

NOTE: Page numbers for previous revisions may differ from page numbers in the current version.

Changes from Revision B (April 2008) to Revision C (April 2024)	Page
• Changed HCT ICC at 25°C single/dual supply.....	5
• Changed t_{en} ADDRESS SEL or \bar{E} to OUT.....	5
• Changed t_{dis} ADDRESS SEL or \bar{E} to OUT.....	5

9 Mechanical, Packaging, and Orderable Information

The following pages include mechanical, packaging, and orderable information. This information is the most current data available for the designated devices. This data is subject to change without notice and revision of this document. For browser-based versions of this data sheet, refer to the left-hand navigation.

PACKAGING INFORMATION

Orderable Device	Status (1)	Package Type	Package Drawing	Pins	Package Qty	Eco Plan (2)	Lead finish/ Ball material (6)	MSL Peak Temp (3)	Op Temp (°C)	Device Marking (4/5)	Samples
CD74HCT4051QM96Q1	ACTIVE	SOIC	D	16	2500	RoHS & Green	NIPDAU	Level-1-260C-UNLIM	-40 to 125	HCT4051Q	Samples
D24051QM96G4Q1	OBSOLETE	SOIC	D	16		TBD	Call TI	Call TI	-40 to 125	HCT4051Q	

(1) The marketing status values are defined as follows:

ACTIVE: Product device recommended for new designs.

LIFEBUY: TI has announced that the device will be discontinued, and a lifetime-buy period is in effect.

NRND: Not recommended for new designs. Device is in production to support existing customers, but TI does not recommend using this part in a new design.

PREVIEW: Device has been announced but is not in production. Samples may or may not be available.

OBSOLETE: TI has discontinued the production of the device.

(2) **RoHS:** TI defines "RoHS" to mean semiconductor products that are compliant with the current EU RoHS requirements for all 10 RoHS substances, including the requirement that RoHS substance do not exceed 0.1% by weight in homogeneous materials. Where designed to be soldered at high temperatures, "RoHS" products are suitable for use in specified lead-free processes. TI may reference these types of products as "Pb-Free".

RoHS Exempt: TI defines "RoHS Exempt" to mean products that contain lead but are compliant with EU RoHS pursuant to a specific EU RoHS exemption.

Green: TI defines "Green" to mean the content of Chlorine (Cl) and Bromine (Br) based flame retardants meet JS709B low halogen requirements of <=1000ppm threshold. Antimony trioxide based flame retardants must also meet the <=1000ppm threshold requirement.

(3) MSL, Peak Temp. - The Moisture Sensitivity Level rating according to the JEDEC industry standard classifications, and peak solder temperature.

(4) There may be additional marking, which relates to the logo, the lot trace code information, or the environmental category on the device.

(5) Multiple Device Markings will be inside parentheses. Only one Device Marking contained in parentheses and separated by a "~" will appear on a device. If a line is indented then it is a continuation of the previous line and the two combined represent the entire Device Marking for that device.

(6) Lead finish/Ball material - Orderable Devices may have multiple material finish options. Finish options are separated by a vertical ruled line. Lead finish/Ball material values may wrap to two lines if the finish value exceeds the maximum column width.

Important Information and Disclaimer: The information provided on this page represents TI's knowledge and belief as of the date that it is provided. TI bases its knowledge and belief on information provided by third parties, and makes no representation or warranty as to the accuracy of such information. Efforts are underway to better integrate information from third parties. TI has taken and continues to take reasonable steps to provide representative and accurate information but may not have conducted destructive testing or chemical analysis on incoming materials and chemicals. TI and TI suppliers consider certain information to be proprietary, and thus CAS numbers and other limited information may not be available for release.

In no event shall TI's liability arising out of such information exceed the total purchase price of the TI part(s) at issue in this document sold by TI to Customer on an annual basis.

OTHER QUALIFIED VERSIONS OF CD74HCT4051-Q1 :

- Catalog : [CD74HCT4051](#)
- Military : [CD54HCT4051](#)

NOTE: Qualified Version Definitions:



- Catalog - TI's standard catalog product
- Military - QML certified for Military and Defense Applications

D (R-PDSO-G16)

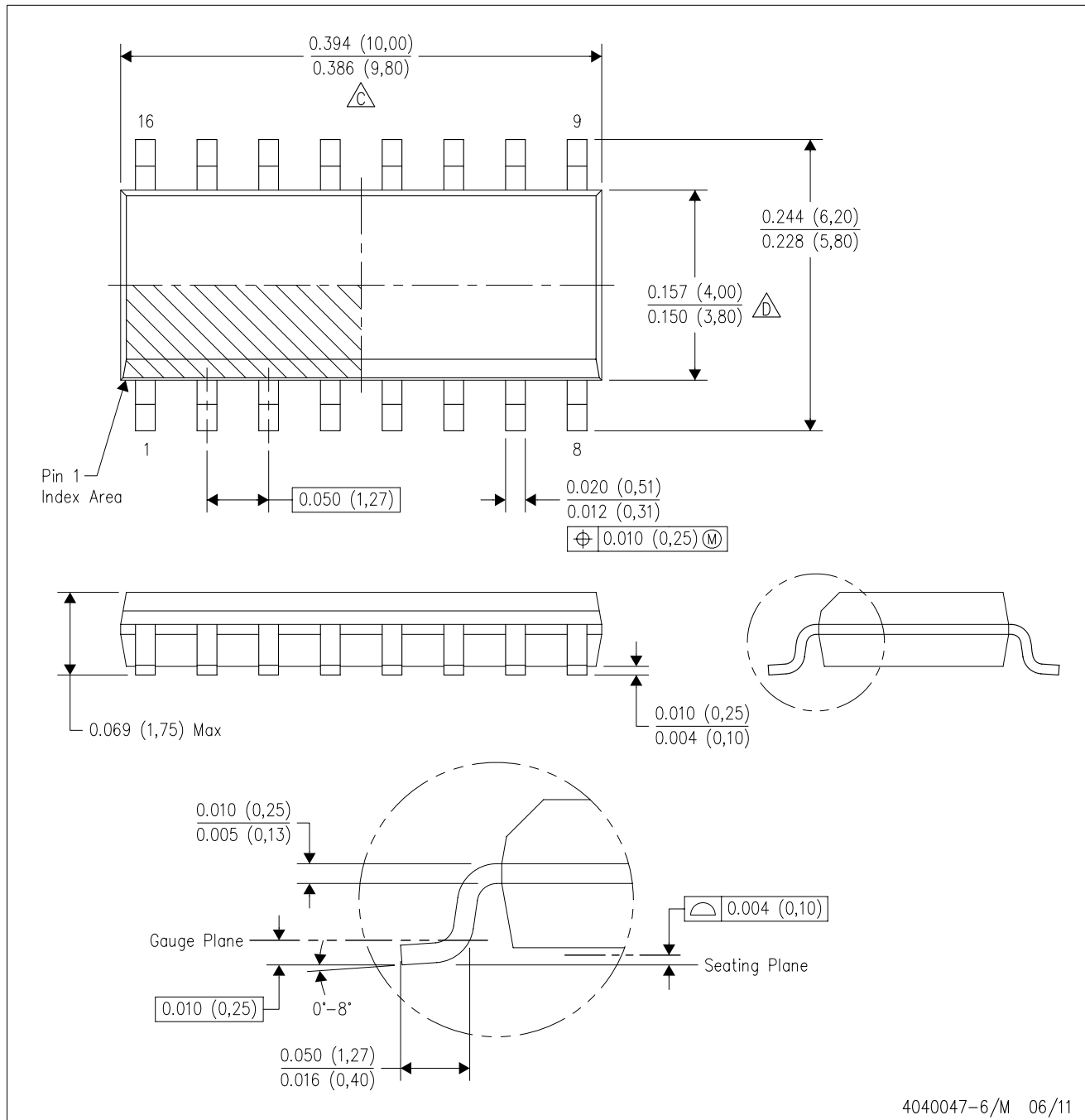
PLASTIC SMALL OUTLINE



4040047-6/M 06/11

- NOTES:
- A. All linear dimensions are in inches (millimeters).
 - B. This drawing is subject to change without notice.
 -  C. Body length does not include mold flash, protrusions, or gate burrs. Mold flash, protrusions, or gate burrs shall not exceed 0.006 (0,15) each side.
 -  D. Body width does not include interlead flash. Interlead flash shall not exceed 0.017 (0,43) each side.
 - E. Reference JEDEC MS-012 variation AC.

IMPORTANT NOTICE AND DISCLAIMER

TI PROVIDES TECHNICAL AND RELIABILITY DATA (INCLUDING DATA SHEETS), DESIGN RESOURCES (INCLUDING REFERENCE DESIGNS), APPLICATION OR OTHER DESIGN ADVICE, WEB TOOLS, SAFETY INFORMATION, AND OTHER RESOURCES "AS IS" AND WITH ALL FAULTS, AND DISCLAIMS ALL WARRANTIES, EXPRESS AND IMPLIED, INCLUDING WITHOUT LIMITATION ANY IMPLIED WARRANTIES OF MERCHANTABILITY, FITNESS FOR A PARTICULAR PURPOSE OR NON-INFRINGEMENT OF THIRD PARTY INTELLECTUAL PROPERTY RIGHTS.

These resources are intended for skilled developers designing with TI products. You are solely responsible for (1) selecting the appropriate TI products for your application, (2) designing, validating and testing your application, and (3) ensuring your application meets applicable standards, and any other safety, security, regulatory or other requirements.

These resources are subject to change without notice. TI grants you permission to use these resources only for development of an application that uses the TI products described in the resource. Other reproduction and display of these resources is prohibited. No license is granted to any other TI intellectual property right or to any third party intellectual property right. TI disclaims responsibility for, and you will fully indemnify TI and its representatives against, any claims, damages, costs, losses, and liabilities arising out of your use of these resources.

TI's products are provided subject to [TI's Terms of Sale](#) or other applicable terms available either on [ti.com](https://www.ti.com) or provided in conjunction with such TI products. TI's provision of these resources does not expand or otherwise alter TI's applicable warranties or warranty disclaimers for TI products.

TI objects to and rejects any additional or different terms you may have proposed.

Mailing Address: Texas Instruments, Post Office Box 655303, Dallas, Texas 75265
Copyright © 2024, Texas Instruments Incorporated