

DRV84x2 Dual Full-Bridge PWM Motor Driver

1 Features

- High-efficiency power stage (up to 97%) with low $R_{DS(on)}$ MOSFETs (110mΩ at $T_J = 25^\circ\text{C}$)
- Operating supply voltage up to 52V
- DRV8412 (Power pad down): up to $2 \times 3\text{A}$ continuous output current ($2 \times 6\text{A}$ peak) in dual full-bridge mode or 6A continuous current in parallel mode (12A peak)
- DRV8432 (Power pad up): up to $2 \times 7\text{A}$ continuous output current ($2 \times 12\text{A}$ peak) in dual full-bridge mode or 14A continuous current in parallel mode (24A peak)
- PWM operating frequency up to 500kHz
- Integrated self-protection circuits including undervoltage, overtemperature, overload, and short circuit
- Programmable cycle-by-cycle current limit protection
- Independent supply and ground pins for each half bridge
- Intelligent gate drive and cross conduction prevention
- No external snubber or schottky diode is required

2 Applications

- Brushed DC and stepper motors
- Three-phase permanent magnet synchronous motors
- Robotic and Haptic control system
- Actuators and pumps
- Precision instruments
- TEC drivers
- LED lighting drivers

3 Description

The DRV841x2 are high-performance, integrated dual full-bridge motor driver with an advanced protection system.

Because of the low $R_{DS(on)}$ of the H-Bridge MOSFETs and intelligent gate drive design, the efficiency of these motor drivers can be up to 97%. This high efficiency enables the use of smaller power supplies and heatsinks, and the devices are good candidates for energy-efficient applications.

The DRV841x2 requires two power supplies, one at 12V for GVDD and VDD, and another up to 50 V for PVDD. The DRV841x2 can operate at up to 500kHz switching frequency while still maintaining precise control and high efficiency. The devices also have an innovative protection system safeguarding the device against a wide range of fault conditions that could damage the system. These safeguards are short-circuit protection, overcurrent protection, undervoltage protection, and two-stage thermal protection. The DRV841x2 has a current-limiting circuit that prevents device shutdown during load transients such as motor start-up. A programmable overcurrent detector allows adjustable current limit and protection level to meet different motor requirements.

The DRV841x2 has unique independent supply and ground pins for each half-bridge. These pins make it possible to provide current measurement through external shunt resistor and support multiple motors with different power supply voltage requirements.

Package Information

PART NUMBER	PACKAGE ⁽¹⁾	PACKAGE SIZE ⁽²⁾
DRV8412	HTSSOP (44)	14 mm x 8.1mm
DRV8432	HSSOP (36)	15.9mm x 14.2mm

(1) For more information, see [Section 9](#).

(2) The package size (length × width) is a nominal value and includes pins, where applicable.

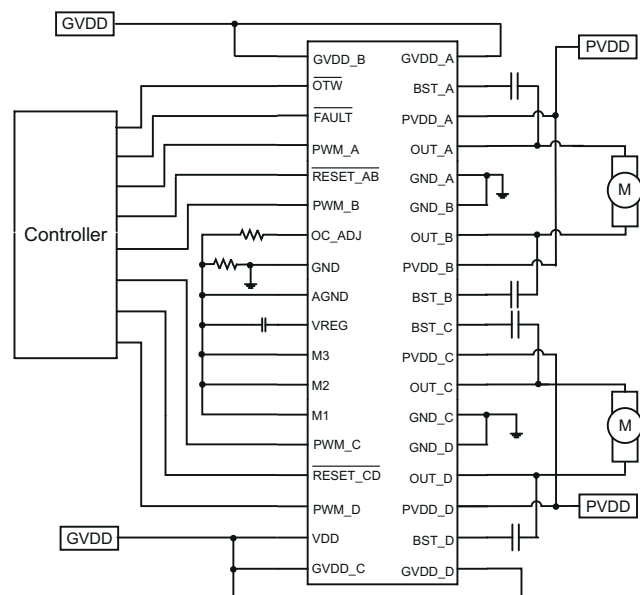

Simplified Application Diagram



Table of Contents

1 Features	1	6 Detailed Description	9
2 Applications	1	6.1 Overview.....	9
3 Description	1	6.2 Functional Block Diagram.....	10
4 Pin Configuration and Functions	3	6.3 Feature Description.....	11
5 Specifications	5	6.4 Device Functional Modes.....	14
5.1 Absolute Maximum Ratings.....	5	7 Device and Documentation Support	29
5.2 ESD Ratings.....	5	7.1 Receiving Notification of Documentation Updates...	29
5.3 Recommended Operating Conditions.....	5	7.2 Support Resources.....	29
5.4 Thermal Information.....	6	7.3 Trademarks.....	29
5.5 Package Heat Dissipation Ratings.....	6	7.4 Electrostatic Discharge Caution.....	29
5.6 Package Power Deratings (DRV8412) ⁽¹⁾	6	7.5 Glossary.....	29
5.7 Electrical Characteristics.....	7	8 Revision History	29
5.8 Typical Characteristics.....	8	9 Mechanical, Packaging, and Orderable Information ..	30

4 Pin Configuration and Functions

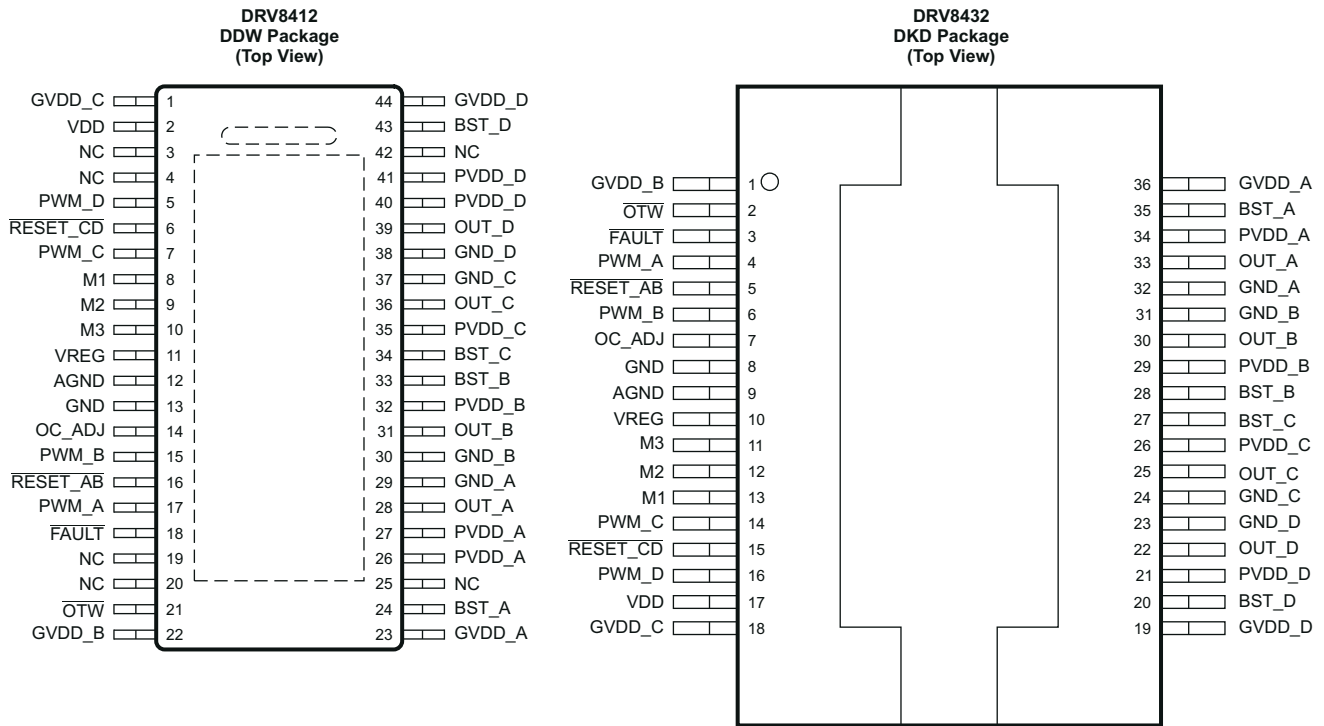

Table 4-1. Pin Functions

NAME	PIN		I/O TYPE ⁽¹⁾	DESCRIPTION
	DRV8412	DRV8432		
AGND	12	9	P	Analog ground
BST_A	24	35	P	High side bootstrap supply (BST), external capacitor to OUT_A required
BST_B	33	28	P	High side bootstrap supply (BST), external capacitor to OUT_B required
BST_C	34	27	P	High side bootstrap supply (BST), external capacitor to OUT_C required
BST_D	43	20	P	High side bootstrap supply (BST), external capacitor to OUT_D required
GND	13	8	P	Ground
GND_A	29	32	P	Power ground for half-bridge A
GND_B	30	31	P	Power ground for half-bridge B
GND_C	37	24	P	Power ground for half-bridge C
GND_D	38	23	P	Power ground for half-bridge D
GVDD_A	23	36	P	Gate-drive voltage supply
GVDD_B	22	1	P	Gate-drive voltage supply
GVDD_C	1	18	P	Gate-drive voltage supply
GVDD_D	44	19	P	Gate-drive voltage supply
M1	8	13	I	Mode selection pin
M2	9	12	I	Mode selection pin
M3	10	11	I	Reserved mode selection pin, AGND connection is recommended
NC	3, 4, 19, 20, 25, 42	—	—	No connection pin. Ground connection is recommended
OC_ADJ	14	7	O	Analog overcurrent programming pin, requires resistor to AGND
OTW	21	2	O	Overtemperature warning signal, open-drain, active-low. An internal pullup resistor to VREG (3.3 V) is provided on output. Level compliance for 5-V logic can be obtained by adding external pullup resistor to 5 V
OUT_A	28	33	O	Output, half-bridge A
OUT_B	31	30	O	Output, half-bridge B
OUT_C	36	25	O	Output, half-bridge C

Table 4-1. Pin Functions (continued)

NAME	PIN		I/O TYPE ⁽¹⁾	DESCRIPTION
	DRV8412	DRV8432		
OUT_D	39	22	O	Output, half-bridge D
PVDD_A	26, 27	34	P	Power supply input for half-bridge A requires close decoupling capacitor to ground.
PVDD_B	32	29	P	Power supply input for half-bridge B requires close decoupling capacitor to ground.
PVDD_C	35	26	P	Power supply input for half-bridge C requires close decoupling capacitor to ground.
PVDD_D	40, 41	21	P	Power supply input for half-bridge D requires close decoupling capacitor to ground.
PWM_A	17	4	I	Input signal for half-bridge A
PWM_B	15	6	I	Input signal for half-bridge B
PWM_C	7	14	I	Input signal for half-bridge C
PWM_D	5	16	I	Input signal for half-bridge D
RESET_AB	16	5	I	Reset signal for half-bridge A and half-bridge B, active-low
RESET_CD	6	15	I	Reset signal for half-bridge C and half-bridge D, active-low
FAULT	18	3	O	Fault signal, open-drain, active-low. An internal pullup resistor to VREG (3.3 V) is provided on output. Level compliance for 5-V logic can be obtained by adding external pullup resistor to 5 V
VDD	2	17	P	Power supply for digital voltage regulator requires capacitor to ground for decoupling.
VREG	11	10	P	Digital regulator supply filter pin requires 0.1-µF capacitor to AGND.
THERMAL PAD	—	N/A	T	Solder the exposed thermal pad to the landing pad on the pcb. Connect landing pad to bottom side of pcb through via for better thermal dissipation. This pad should be connected to GND.
HEAT SLUG	N/A	—	T	Mount heat sink with thermal interface on top of the heat slug for best thermal performance.

(1) I = input, O = output, P = power, T = thermal

Table 4-2. Mode Selection Pins

MODE PINS			OUTPUT CONFIGURATION	DESCRIPTION
M3	M2	M1		
0	0	0	2 FB or 4 HB	Dual full bridges (two PWM inputs each full bridge) or four half bridges with cycle-by-cycle current limit
0	0	1	2 FB or 4 HB	Dual full bridges (two PWM inputs each full bridge) or four half bridges with OC latching shutdown (no cycle-by-cycle current limit)
0	1	0	1 PFB	Parallel full bridge with cycle-by-cycle current limit
0	1	1	2 FB	Dual full bridges (one PWM input each full bridge with complementary PWM on second half bridge) with cycle-by-cycle current limit
1	x	x	Reserved	

5 Specifications

5.1 Absolute Maximum Ratings

over operating free-air temperature range (unless otherwise noted)⁽¹⁾

	MIN	MAX	UNIT
VDD to GND	-0.3	13.2	V
GVDD_X to GND	-0.3	13.2	V
PVDD_X to GND_X ⁽²⁾	-0.3	70	V
OUT_X to GND_X ⁽²⁾	-0.3	70	V
BST_X to GND_X ⁽²⁾	-0.3	80	V
Transient peak output current (per pin), pulse width limited by internal overcurrent protection circuit		16	A
Transient peak output current for latch shut down (per pin)		20	A
VREG to AGND	-0.3	4.2	V
GND_X to GND	-0.3	0.3	V
GND to AGND	-0.3	0.3	V
PWM_X to GND	-0.3	V _{REG} + 0.5	V
OC_ADJ, M1, M2, M3 to AGND	-0.3	4.2	V
RESET_X, FAULT, OTW to GND	-0.3	7	V
Continuous sink current ($\overline{\text{FAULT}}$, $\overline{\text{OTW}}$)		9	mA
Operating junction temperature, T _J	-40	150	°C
Storage temperature, T _{stg}	-55	150	

- (1) Stresses beyond those listed under *Absolute Maximum Ratings* may cause permanent damage to the device. These are stress ratings only, which do not imply functional operation of the device at these or any other conditions beyond those indicated under [Section 5.3](#). Exposure to absolute-maximum-rated conditions for extended periods may affect device reliability.
- (2) These are the maximum allowed voltages for transient spikes. Absolute maximum DC voltages are lower.

5.2 ESD Ratings

	VALUE	UNIT
V _(ESD) Electrostatic discharge	Charged device model (CDM), per JEDEC specification JESD22-C101, all pins ⁽¹⁾	±1500 V

- (1) JEDEC document JEP157 states that 250-V CDM allows safe manufacturing with a standard ESD control process.

5.3 Recommended Operating Conditions

over operating free-air temperature range (unless otherwise noted)

	MIN	NOM	MAX	UNIT
PVDD_X Half bridge X (A, B, C, or D) DC supply voltage	0	50	52.5	V
GVDD_X Supply for logic regulators and gate-drive circuitry	10.8	12	13.2	
VDD Digital regulator supply voltage	10.8	12	13.2	
I _{O_PULSE} Pulsed peak current per output pin (could be limited by thermal)			15	A
I _O Continuous current per output pin (DRV8432)			9	mA
F _{SW} PWM switching frequency			500	kHz
R _{OCP_OBC} OC programming resistor range in cycle-by-cycle current limit modes	24		200	kΩ
R _{OCP_OCL} OC programming resistor range in OC latching shutdown modes	22		200	
C _{BST} Bootstrap capacitor range	33		220	nF
t _{ON_MIN} Minimum PWM pulse duration, low side, for charging the Bootstrap capacitor		50		ns
T _A Operating ambient temperature	-40		85	°C

5.4 Thermal Information

THERMAL METRIC ⁽¹⁾		DRV8412	DRV8432	UNIT
		DDW PACKAGE	DKD PACKAGE	
		44 PINS	36 PINS	
R _{θJA}	Junction-to-ambient thermal resistance	24.5	13.3 (with heat sink)	°C/W
R _{θJC(top)}	Junction-to-case (top) thermal resistance	7.8	0.4	
R _{θJB}	Junction-to-board thermal resistance	5.5	13.3	
ψ _{JT}	Junction-to-top characterization parameter	0.1	0.4	
ψ _{JB}	Junction-to-board characterization parameter	5.4	13.3	
R _{θJC(bot)}	Junction-to-case (bottom) thermal resistance	0.2	N/A	

(1) for more information about traditional and new thermal metrics, see the *IC Package Thermal Metrics* application report, [SPRA953](#).

5.5 Package Heat Dissipation Ratings

PARAMETER	DRV8412	DRV8432
R _{θJC} , junction-to-case (power pad / heat slug) thermal resistance	1.1 °C/W	0.9 °C/W
R _{θJA} , junction-to-ambient thermal resistance	25 °C/W	This device is not intended to be used without a heatsink. Therefore, R _{θJA} is not specified. See the <i>Thermal Information</i> section.
Exposed power pad / heat slug area	34 mm ²	80 mm ²

5.6 Package Power Deratings (DRV8412)⁽¹⁾

PACKAGE	T _A = 25°C POWER RATING	DERATING FACTOR ABOVE T _A = 25°C	T _A = 70°C POWER RATING	T _A = 85°C POWER RATING	T _A = 125°C POWER RATING
44-PIN TSSOP (DDW)	5.0 W	40.0 mW/°C	3.2 W	2.6 W	1.0 W

(1) Based on EVM board layout

5.7 Electrical Characteristics

$T_A = 25^\circ\text{C}$, $PVDD = 50\text{V}$, $GVDD = VDD = 12\text{V}$, $f_{\text{SW}} = 400\text{kHz}$, unless otherwise noted. All performance is in accordance with recommended operating conditions unless otherwise specified.

PARAMETER		TEST CONDITIONS	MIN	TYP	MAX	UNIT
INTERNAL VOLTAGE REGULATOR AND CURRENT CONSUMPTION						
V_{REG}	Voltage regulator, only used as a reference node	$VDD = 12\text{V}$	2.95	3.3	3.65	V
I_{VDD}	VDD supply current	Idle, reset mode		9	12	mA
		Operating, 50% duty cycle		10.5		
I_{GVDD_X}	Gate supply current per half-bridge	Reset mode		1.7	2.5	mA
		Operating, 50% duty cycle		8		
I_{PVDD_X}	Half-bridge X (A, B, C, or D) idle current	Reset mode		0.7	1	mA
OUTPUT STAGE						
$R_{\text{DS(on)}}$	MOSFET drain-to-source resistance, low side (LS)	$T_J = 25^\circ\text{C}$, $GVDD = 12\text{V}$, Includes metallization bond wire and pin resistance		110		m Ω
	MOSFET drain-to-source resistance, high side (HS)	$T_J = 25^\circ\text{C}$, $GVDD = 12\text{V}$, Includes metallization bond wire and pin resistance		110		
V_F	Diode forward voltage drop	$T_J = 25^\circ\text{C} - 125^\circ\text{C}$, $I_O = 5\text{A}$		1		V
t_R	Output rise time	Resistive load, $I_O = 5\text{A}$		14		ns
t_F	Output fall time	Resistive load, $I_O = 5\text{A}$		14		
$t_{\text{PD_ON}}$	Propagation delay when FET is on	Resistive load, $I_O = 5\text{A}$		38		
$t_{\text{PD_OFF}}$	Propagation delay when FET is off	Resistive load, $I_O = 5\text{A}$		38		
t_{DT}	Dead time between HS and LS FETs	Resistive load, $I_O = 5\text{A}$		5.5		
I/O PROTECTION						
$V_{\text{uvp,G}}$	Gate supply voltage $GVDD_X$ undervoltage protection threshold			8.5		V
$V_{\text{uvp,hyst}}^{(1)}$	Hysteresis for gate supply undervoltage event			0.8		
$OTW^{(1)}$	Overtemperature warning		115	125	135	$^\circ\text{C}$
$OTW_{\text{hyst}}^{(1)}$	Hysteresis temperature to reset OTW event			25		
$OTSD^{(1)}$	Overtemperature shut down			150		
$OTE-OTW_{\text{differential}}^{(1)}$	OTE- OTW overtemperature detect temperature difference			25		
$OTSD_{\text{HYST}}^{(1)}$	Hysteresis temperature for $\overline{\text{FAULT}}$ to be released following an $OTSD$ event			25		
I_{OC}	Overcurrent limit protection	Resistor—programmable, nominal, $R_{\text{OCP}} = 27\text{ k}\Omega$		9.7		A
I_{OCT}	Overcurrent response time	Time from application of short condition to Hi-Z of affected FET(s)		250		ns
R_{PD}	Internal pulldown resistor at the output of each half-bridge	Connected when $\overline{\text{RESET_AB}}$ or $\overline{\text{RESET_CD}}$ is active to provide bootstrap capacitor charge		1		k Ω
STATIC DIGITAL SPECIFICATIONS						
V_{IH}	High-level input voltage	PWM_A, PWM_B, PWM_C, PWM_D, M1, M2, M3	2		3.6	V
V_{IH}	High-level input voltage	$\overline{\text{RESET_AB}}$, $\overline{\text{RESET_CD}}$	2		5.5	
V_{IL}	Low-level input voltage	PWM_A, PWM_B, PWM_C, PWM_D, M1, M2, M3, $\overline{\text{RESET_AB}}$, $\overline{\text{RESET_CD}}$			0.8	
I_{Ikg}	Input leakage current		-100		100	μA
OTW / FAULT						
$R_{\text{INT_PU}}$	Internal pullup resistance, $\overline{\text{OTW}}$ to V_{REG} , $\overline{\text{FAULT}}$ to V_{REG}		20	26	35	k Ω
V_{OH}	High-level output voltage	Internal pullup resistor only	2.95	3.3	3.65	V
		External pullup of 4.7 k Ω to 5 V	4.5		5	
V_{OL}	Low-level output voltage	$I_O = 4\text{ mA}$		0.2	0.4	

(1) Specified by design

5.8 Typical Characteristics

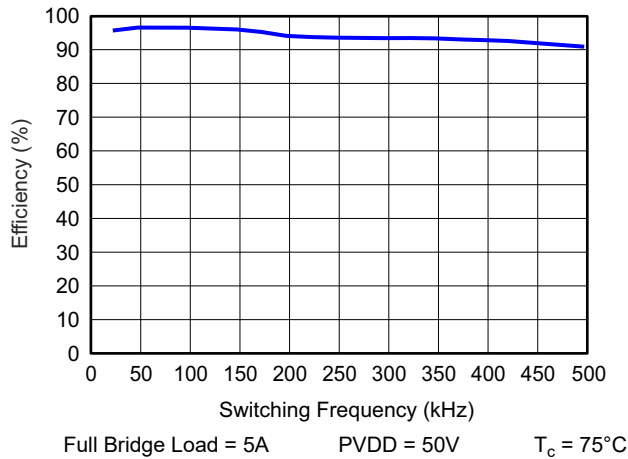

Figure 5-1. Efficiency vs Switching Frequency (DRV8432)

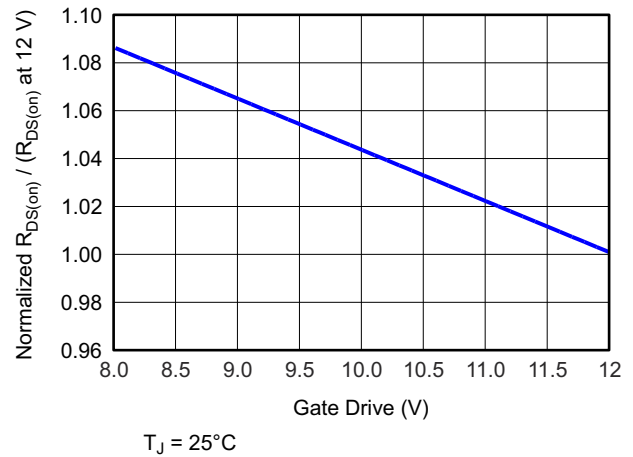

Figure 5-2. Normalized RDS(On) vs Gate Drive

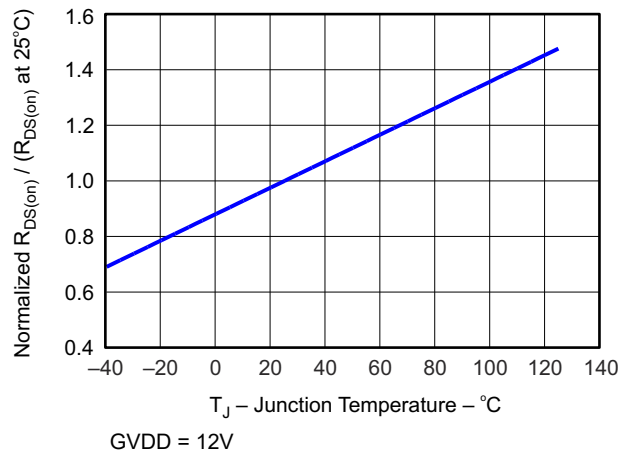

Figure 5-3. Normalized Rds(On) vs Junction Temperature

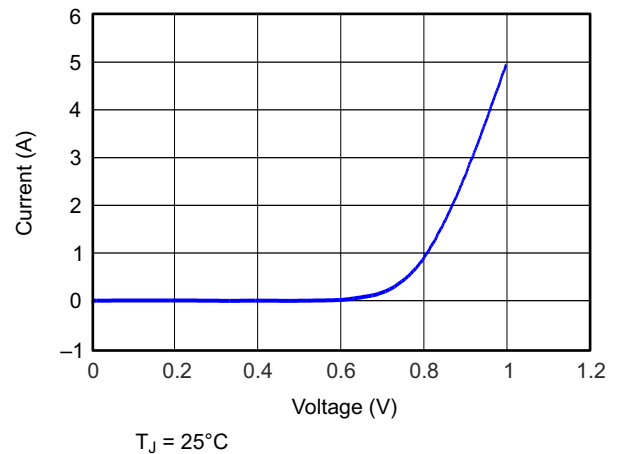

Figure 5-4. Drain To Source Diode Forward On Characteristics

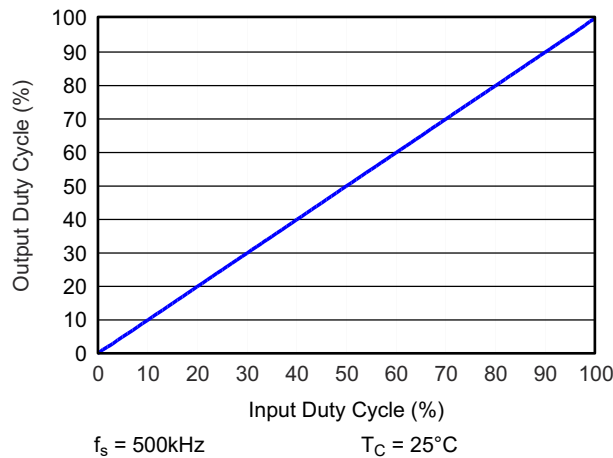

Figure 5-5. Output Duty Cycle vs Input Duty Cycle

6 Detailed Description

6.1 Overview

The DRV841x2 is a high performance, integrated dual full bridge motor driver with an advanced protection system.

Because of the low $R_{DS(on)}$ of the H-Bridge MOSFETs and intelligent gate drive design, the efficiency of these motor drivers can be up to 97%, which enables the use of smaller power supplies and heatsinks, and are good candidates for energy efficient applications.

6.2 Functional Block Diagram

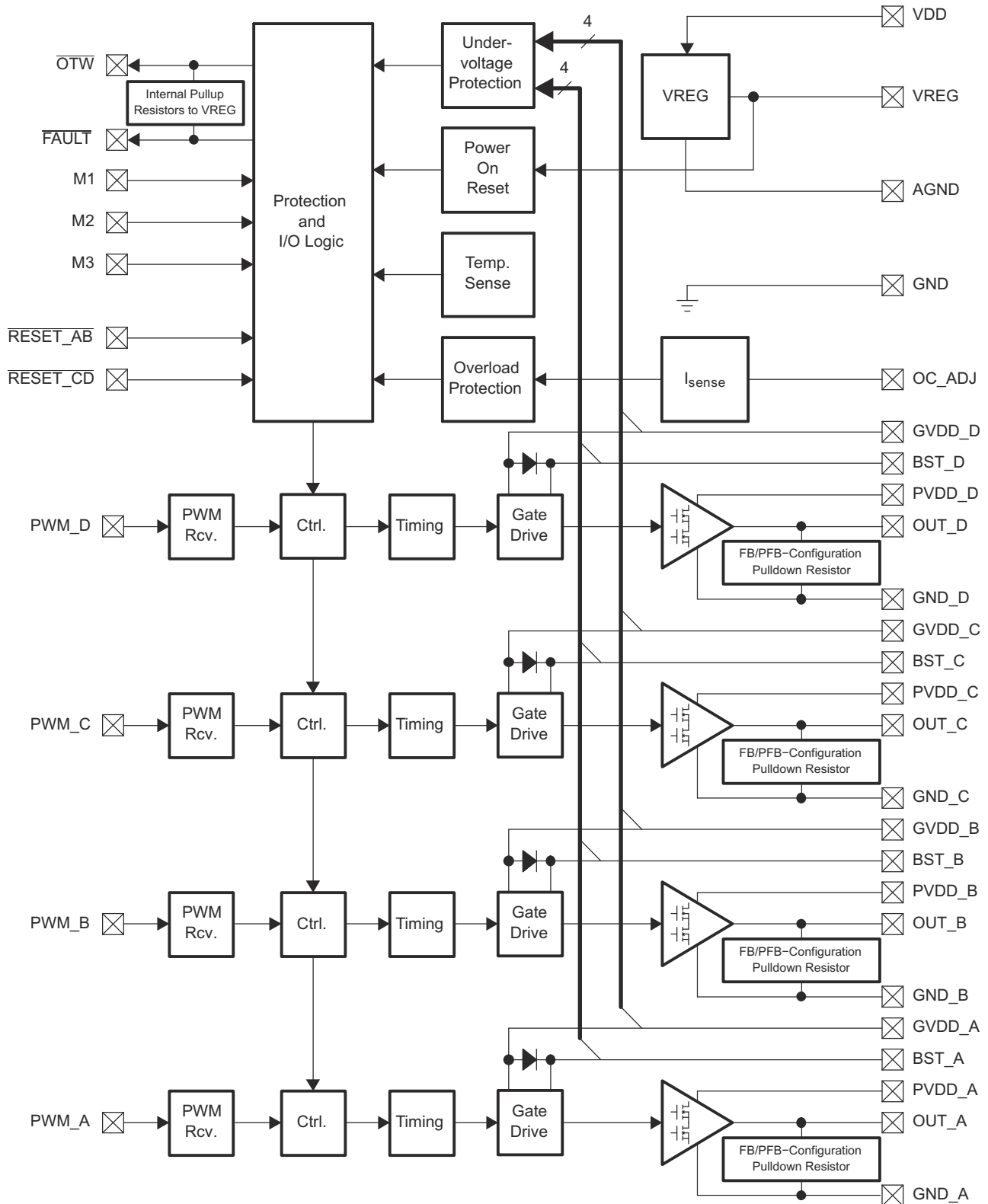

6.3 Feature Description

6.3.1 Error Reporting

The $\overline{\text{FAULT}}$ and $\overline{\text{OTW}}$ pins are both active-low, open-drain outputs. Their function is for protection-mode signaling to a PWM controller or other system-control device.

Any fault resulting in device shutdown, such as overtemperature shutdown, overcurrent shutdown, or undervoltage protection, is signaled by the $\overline{\text{FAULT}}$ pin going low. Also, $\overline{\text{OTW}}$ goes low when the device junction temperature exceeds 125°C (see Table 6-1).

Table 6-1. Protection Mode Signal Descriptions

FAULT	OTW	DESCRIPTION
0	0	Overtemperature warning and (overtemperature shut-down or overcurrent shut-down or undervoltage protection) occurred
0	1	Overcurrent shut-down or GVDD undervoltage protection occurred
1	0	Overtemperature warning
1	1	Device under normal operation

TI recommends monitoring the $\overline{\text{OTW}}$ signal using the system microcontroller and responding to an $\overline{\text{OTW}}$ signal by reducing the load current to prevent further heating of the device resulting in device overtemperature shutdown (OTSD).

To reduce external component count, an internal pullup resistor to VREG (3.3V) is provided on both $\overline{\text{FAULT}}$ and $\overline{\text{OTW}}$ outputs. Level compliance for 5V logic can be obtained by adding external pullup resistors to 5V (see the *Electrical Characteristics* section of this data sheet for further specifications).

6.3.2 Device Protection System

The DRV841x2 contains advanced protection circuitry carefully designed to facilitate system integration and ease of use, as well as to safeguard the device from permanent failure due to a wide range of fault conditions such as short circuits, overcurrent, overtemperature, and undervoltage. The DRV841x2 responds to a fault by immediately setting the half bridge outputs in a high-impedance (Hi-Z) state and asserting the $\overline{\text{FAULT}}$ pin low. In situations other than overcurrent or overtemperature, the device automatically recovers when the fault condition has been removed or the gate supply voltage has increased. For highest possible reliability, reset the device externally no sooner than 1 second after the shutdown when recovering from an overcurrent shut down (OCSD) or OTSD fault.

6.3.2.1 Bootstrap Capacitor Undervoltage Protection

When the device runs at a low switching frequency (for example, less than 10 kHz with a 100-nF bootstrap capacitor), the bootstrap capacitor voltage might not be able to maintain a proper voltage level for the high-side gate driver. A bootstrap capacitor undervoltage protection circuit (BST_UVP) prevents potential failure of the high-side MOSFET. When the voltage on the bootstrap capacitors is less than the required value for safe operation, the DRV841x2 initiates bootstrap capacitor recharge sequences (turn off high side FET for a short period) until the bootstrap capacitors are properly charged for safe operation. This function may also be activated when PWM duty cycle is too high (for example, less than 20ns off time at 10kHz). Note that bootstrap capacitor might not be able to be charged if no load or extremely light load is presented at output during BST_UVP operation, so it is recommended to turn on the low side FET for at least 50 ns for each PWM cycle to avoid BST_UVP operation if possible.

For applications with lower than 10-kHz switching frequency and not to trigger BST_UVP protection, a larger bootstrap capacitor can be used (for example, 1- μ F capacitor for 800-Hz operation). When using a bootstrap cap larger than 220 nF, it is recommended to add 5- Ω resistors between 12-V GVDD power supply and GVDD_X pins to limit the inrush current on the internal bootstrap circuitry.

6.3.2.2 Overcurrent (OC) Protection

The DRV841x2 has independent, fast-reacting current detectors with programmable trip threshold (OC threshold) on all high-side and low-side power-stage FETs. There are two settings for OC protection through mode selection pins: cycle-by-cycle (CBC) current limiting mode and OC latching (OCL) shut down mode.

In CBC current limiting mode, the detector outputs are monitored by two protection systems. The first protection system controls the power stage to prevent the output current from further increasing, that is, performing as a CBC current-limiting function rather than prematurely shutting down the device. This feature could effectively limit the inrush current during motor start-up or transient without damaging the device. During short to power and short to ground conditions, the current limit circuitry might not be able to control the current to a proper level, a second protection system triggers a latching shutdown, resulting in the related half bridge being set in the high-impedance (Hi-Z) state. Current limiting and overcurrent protection are independent for half-bridges A, B, C, and, D, respectively.

Figure 6-1 illustrates cycle-by-cycle operation with high side OC event and Figure 6-2 shows cycle-by-cycle operation with low side OC. Dashed lines are the operation waveforms when no CBC event is triggered and solid lines show the waveforms when CBC event is triggered. In CBC current limiting mode, when low side FET OC is detected, the device turns off the affected low side FET and keep the high side FET at the same half bridge off until the next PWM cycle. When high side FET OC is detected, the device turns off the affected high side FET and turn on the low side FET at the half bridge until next PWM cycle.

It is important to note that if the input to a half bridge is held to a constant value when an over current event occurs in CBC, then the associated half bridge will be in a HI-Z state upon the over current event ending. Cycling IN_X allows OUT_X to resume normal operation.

In OC latching shut down mode, the CBC current limit and error recovery circuits are disabled and an overcurrent condition will cause the device to shutdown immediately. After shutdown, RESET_AB and/or RESET_CD must be asserted to restore normal operation after the overcurrent condition is removed.

For added flexibility, the OC threshold is programmable using a single external resistor connected between the OC_ADJ pin and GND pin. See Table 6-2 for information on the correlation between programming-resistor value and the OC threshold. The values in Table 6-2 show typical OC thresholds for a given resistor. Assuming a fixed resistance on the OC_ADJ pin across multiple devices, a 20% device-to-device variation in OC threshold measurements is possible. Therefore, this feature is designed for system protection and not for precise current control. Note that a properly functioning overcurrent detector assumes the presence of a proper inductor or power ferrite bead at the power-stage output. Short-circuit protection is not guaranteed with direct short at the output pins of the power stage.

For normal operation, inductance in motor (assume larger than 10 μ H) is sufficient to provide low di/dt output (for example, for EMI) and proper protection during overload condition (CBC current limiting feature). So no additional output inductors are needed during normal operation.

However, during a short condition, the motor (or other load) is shorted, so the load inductance is not present in the system anymore; the current in the device can reach such a high level that may exceed the abs max current rating due to extremely low impedance in the short circuit path and high di/dt before oc detection circuit kicks in. So, a ferrite bead or inductor is recommended to use the short-circuit protection feature in DRV841x2. With an external inductance or ferrite bead, the current rises at a much slower rate and reach a lower current level before oc protection starts. The device then either operates CBC current limit or OC shut down automatically (when current is well above the current limit threshold) to protect the system.

For a system that has limited space, a power ferrite bead can be used instead of an inductor. The current rating of ferrite bead has to be higher than the RMS current of the system at normal operation. A ferrite bead designed for very high frequency is NOT recommended. A minimum impedance of 10 Ω or higher is recommended at 10MHz or lower frequency to effectively limit the current rising rate during short circuit condition.

The TDK MPZ2012S300A (with size of 0805 inch type) have been tested in our system to meet a short circuit condition in the DRV8412. But other ferrite beads that have similar frequency characteristics can be used as well.

For higher power applications, such as in the DRV8432, there might be limited options to select suitable ferrite bead with high current rating. If an adequate ferrite bead cannot be found, an inductor can be used.

The inductance can be calculated as:

$$L_{oc_min} = \frac{PVDD \cdot T_{oc_delay}}{I_{peak} - I_{ave}} \quad (1)$$

where

- $T_{oc_delay} = 250\text{nS}$
- $I_{peak} = 15\text{A}$ (below abs max rating)

Because an inductor usually saturates after reaching the current rating, the recommendation is to use an inductor with a doubled value or an inductor with a current rating well above the operating condition.

Table 6-2. Programming-Resistor Values and OC Threshold

OC-ADJUST RESISTOR VALUES (kΩ)	MAXIMUM CURRENT BEFORE OC OCCURS (A)
22 ⁽¹⁾	11.6
24	10.7
27	9.7
30	8.8
36	7.4

(1) Recommended to use in OC Latching Mode Only

6.3.2.3 Overtemperature Protection

The DRV841x2 has a two-level temperature-protection system that asserts an active-low warning signal (\overline{OTW}) when the device junction temperature exceeds 125°C (nominal) and, if the device junction temperature exceeds 150°C (nominal), the device is put into thermal shutdown, resulting in all half-bridge outputs being set in the high-impedance (Hi-Z) state and \overline{FAULT} being asserted low. OTSD is latched in this case and $\overline{RESET_AB}$ and $\overline{RESET_CD}$ must be asserted low to clear the latch.

6.3.2.4 Undervoltage Protection (UVP) and Power-On Reset (POR)

The UVP and POR circuits of the DRV841x2 fully protect the device in any power-up/down and brownout situation. While powering up, the POR circuit resets the overcurrent circuit and ensures that all circuits are fully operational when the GVDD_X and VDD supply voltages reach 9.8 V (typical). Although GVDD_X and VDD are independently monitored, a supply voltage drop below the UVP threshold on any VDD or GVDD_X pin results in all half-bridge outputs immediately being set in the high-impedance (Hi-Z) state and \overline{FAULT} being asserted low. The device automatically resumes operation when all supply voltage on the bootstrap capacitors have increased above the UVP threshold.

6.3.3 Device Reset

Two reset pins are provided for independent control of half-bridges A/B and C/D. When $\overline{RESET_AB}$ is asserted low, all four power-stage FETs in half-bridges A and B are forced into a high-impedance (Hi-Z) state. Likewise, asserting $\overline{RESET_CD}$ low forces all four power-stage FETs in half-bridges C and D into a high-impedance state. To accommodate bootstrap charging prior to switching start, asserting the reset inputs low enables weak pull-down of the half-bridge outputs.

A rising-edge transition on reset input allows the device to resume operation after a shut-down fault. For example, when either or both half-bridge A and B have OC shutdown, a low to high transition of $\overline{RESET_AB}$ pin clears the fault and \overline{FAULT} pin; when either or both half-bridge C and D have OC shutdown, a low to high transition of $\overline{RESET_CD}$ pin will clear the fault and \overline{FAULT} pin as well. When an OTSD occurs, both $\overline{RESET_AB}$ and $\overline{RESET_CD}$ need to have a low to high transition to clear the fault and \overline{FAULT} signal.

6.4 Device Functional Modes

The DRV841x2 supports four different modes of operation:

1. Dual full bridges (FB) (two PWM inputs each full bridge) or four half bridges (HB) with CBC current limit
2. Dual full bridges (two PWM inputs each full bridge) or four half bridges with OC latching shutdown (no CBC current limit)
3. Parallel full bridge (PFB) with CBC current limit
4. Dual full bridges (one PWM input each full bridge) with CBC current limit

In mode 1 and 2, PWM_A controls half bridge A, PWM_B controls half bridge B, and so forth [Figure 7-1](#) shows an application example for full bridge mode operation.

In parallel full bridge mode (mode 3), PWM_A controls both half bridges A and B, and PWM_B controls both half bridges C and D, while PWM_C and PWM_D pins are not used (recommended to connect to ground). Bridges A and B are synchronized internally (even during CBC), and so are bridges C and D. OUT_A and OUT_B should be connected together and OUT_C and OUT_D should be connected together after the output inductor or ferrite bead. If RESET_AB or RESET_CD are low, all four outputs become high-impedance. [Figure 7-8](#) shows an example of parallel full bridge mode connection.

In mode 4, one PWM signal controls one full bridge to relieve some I/O resource from MCU, that is, PWM_A controls half bridges A and B and PWM_C controls half bridges C and D. In this mode, the operation of half bridge B is complementary to half bridge A, and the operation of half bridge D is complementary to half bridge C. For example, when PWM_A is high, high side FET in half bridge A and low side FET in half bridge B will be on and low side FET in half bridge A and high side FET in half bridge B will be off. Since PWM_B and PWM_D pins are not used in this mode, it is recommended to connect them to ground.

In operation modes 1, 2, and 4 (CBC current limit is used), once the CBC current limit is hit, the driver will be deactivated until the next PWM cycle starts. However, in order for the output to be recovered, the PWM input corresponding to that driver in CBC must be toggled. Because of this, CBC mode does not support operation when one half-bridge PWM input is tied to dc logic level.

Because each half bridge has independent supply and ground pins, a shunt sensing resistor can be inserted between PVDD to PVDD_X or GND_X to GND (ground plane). A high side shunt resistor between PVDD and PVDD_X is recommended for differential current sensing because a high bias voltage on the low side sensing could affect device operation. If low side sensing has to be used, a shunt resistor value of 10 mΩ or less or sense voltage 100mV or less is recommended.

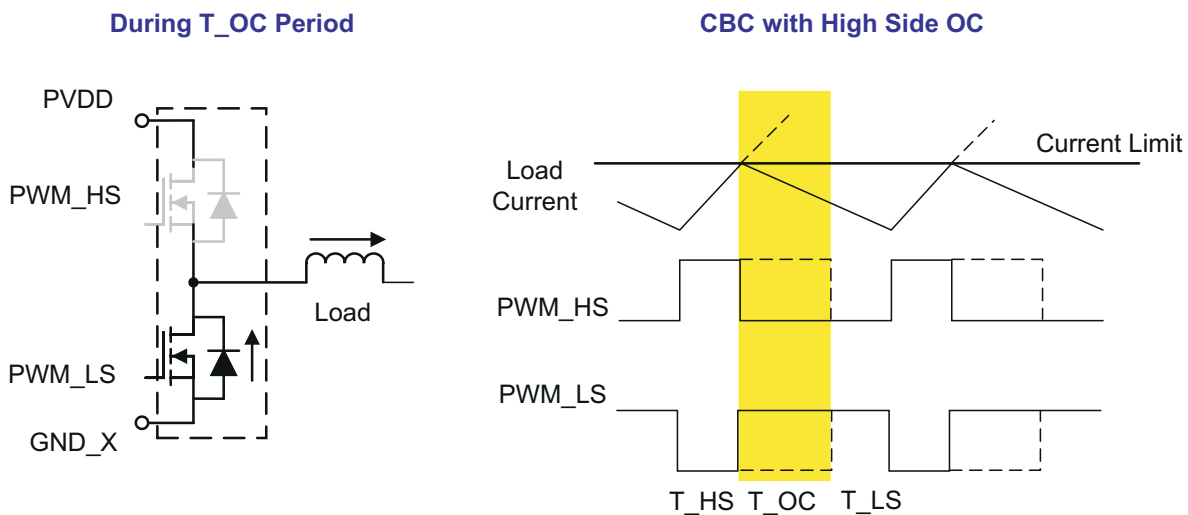

Dashed line: normal operation; solid line: CBC event

Figure 6-1. Cycle-by-Cycle Operation With High-Side OC

During T_{OC} Period

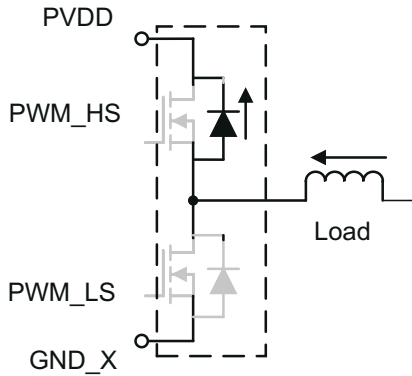

CBC with Low Side OC

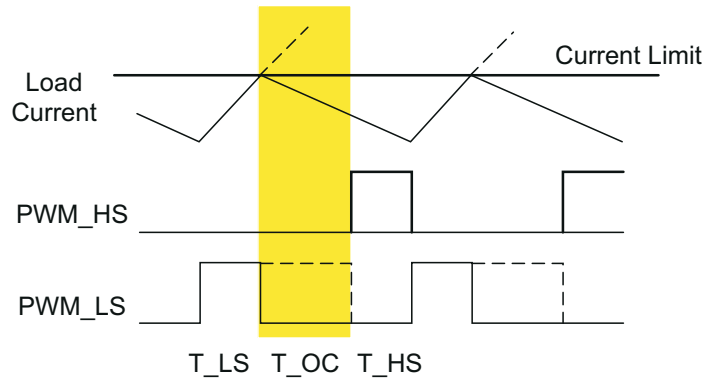

Dashed line: normal operation; solid line: CBC event

Figure 6-2. Cycle-by-Cycle Operation With Low-Side OC

Application and Implementation

Note

Information in the following applications sections is not part of the TI component specification, and TI does not warrant its accuracy or completeness. TI's customers are responsible for determining suitability of components for their purposes. Customers should validate and test their design implementation to confirm system functionality.

1 Application Information

The DRV841x2 devices are typically used to drive 2 brushed DC or 1 stepper motor.

The DRV841x2 can be used for stepper motor applications as illustrated in [Figure 7-9](#); the devices can be also used in three phase permanent magnet synchronous motor (PMSM) and sinewave brushless DC motor applications.

[Figure 7-10](#) shows an example of a TEC driver application. The same configuration can also be used for DC output applications.

2 Typical Applications

2.1 Full Bridge Mode Operation

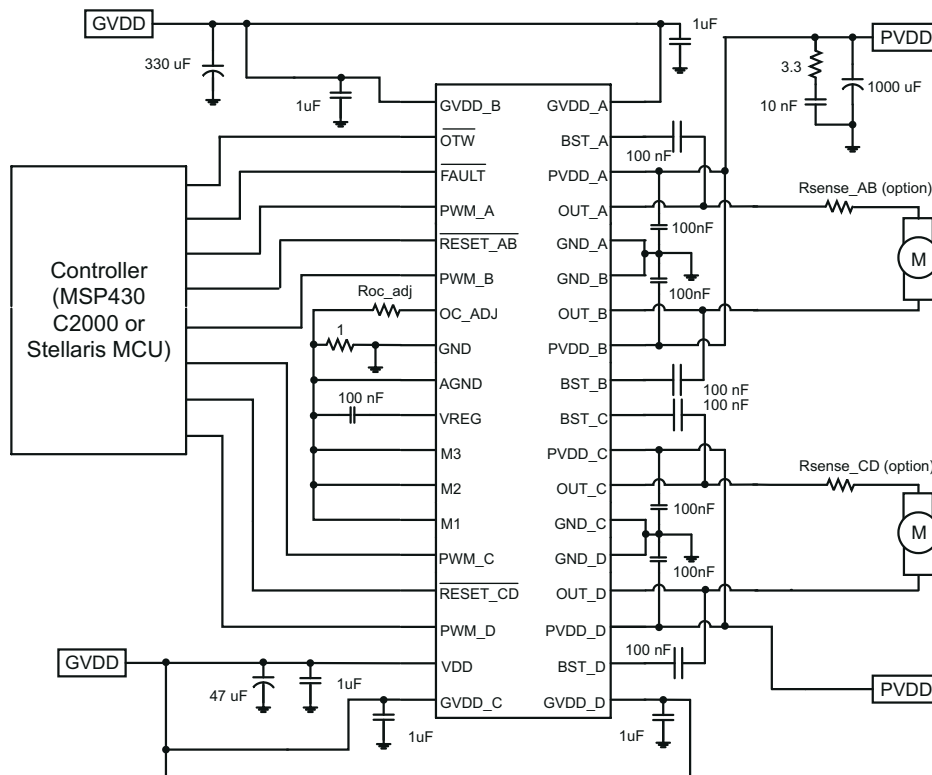

Figure 7-1. Application Diagram Example for Full Bridge Mode Operation Schematic

2.1.1 Design Requirements

This section describes design considerations.

Table 7-1. Design Parameters

DESIGN PARAMETER	REFERENCE	EXAMPLE VALUE
Motor voltage	PVDD_x	24V
Motor current (peak and RMS)	I _{PVDD}	6A peak, 3A RMS
Overcurrent threshold	OC _{TH}	OC_ADJ = 27kΩ, 9.7A
Bridge mode	M1M2	Parallel full bridge

2.1.2 Detailed Design Procedure

2.1.2.1 Motor Voltage

Higher voltages generally have the advantage of causing current to change faster through the inductive windings, which allows for higher RPMs. Lower voltages allow for more accurate control of phase currents.

2.1.2.2 Current Requirement of 12V Power Supply

The DRV83x2 requires a 12V power supply for GVDD and VDD pins. The total supply current is relatively low at room temperature (less than 50mA), but the current could increase significantly when the device temperature goes too high (for example, above 125°C), especially at heavy load conditions due to substrate current collection by 12V guard rings. TI recommends designing the 12V power supply with a current capability at least 5-10% of the load current, and no less than 100mA for the device performance across all temperature ranges.

2.1.2.3 Voltage of Decoupling Capacitor

The voltage of the decoupling capacitors should be selected in accordance with good design practices. Temperature, ripple current, and voltage overshoot must be considered. The high frequency decoupling capacitor should use ceramic capacitor with X5R or better rating. For a 50V application, a minimum voltage rating of 63V is recommended.

2.1.2.4 Overcurrent Threshold

When choosing the resistor value for OC_ADJ, consider the peak current allowed under normal system behavior, the resistor tolerance, and that [Table 6-2](#) currents have a ±10% tolerance. For example, if 6A is the highest system current allowed across all normal behavior, a 27kΩ OC_ADJ resistor with 10% tolerance is a reasonable choice, as it would set the OC_{TH} to approximately 8A to 12A.

2.1.2.5 Sense Resistor

For optimal performance, the sense resistor must be:

- Surface-mount
- Low inductance
- Rated for high enough power
- Placed closely to the motor driver

The power dissipated by the sense resistor equals $I_{RMS}^2 \times R$. For example, if peak motor current is 3A, RMS motor current is 2A, and a 0.05Ω sense resistor is used, the resistor will dissipate $2A^2 \times 0.05\Omega = 0.2W$. The power increases quickly with higher current levels.

Resistors typically have a rated power within some ambient temperature range, along with a de-rated power curve for high ambient temperatures. When a PCB is shared with other components generating heat, margin should be added. Always measure the actual sense resistor temperature in a final system, along with the power MOSFETs, as those are often the hottest components.

Because power resistors are larger and more expensive than standard resistors, use multiple standard resistors in parallel, between the sense node and ground. This distributes the current and heat dissipation.

2.1.3 Application Curves

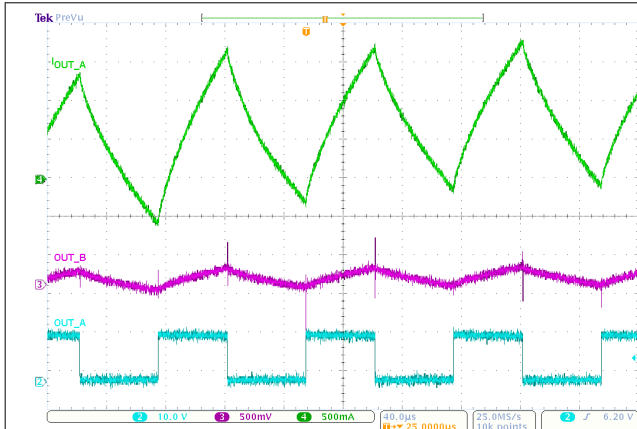

Figure 7-2. Brushed DC Driving

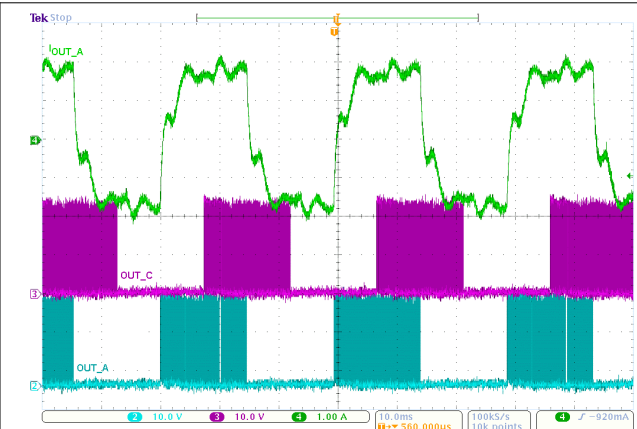

Figure 7-3. Stepper Control, Full Stepping, 24V

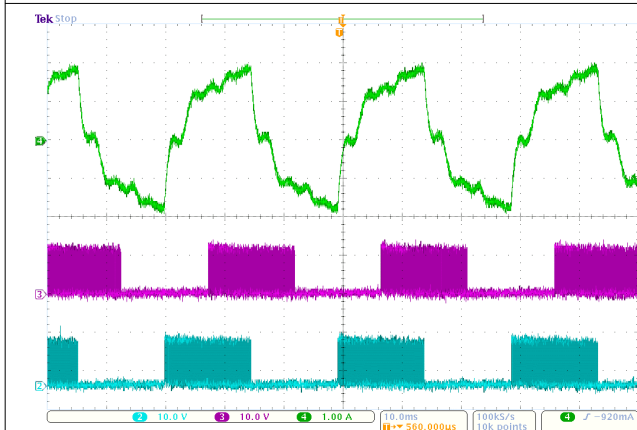

Figure 7-4. Stepper Control, Full Stepping, 12V

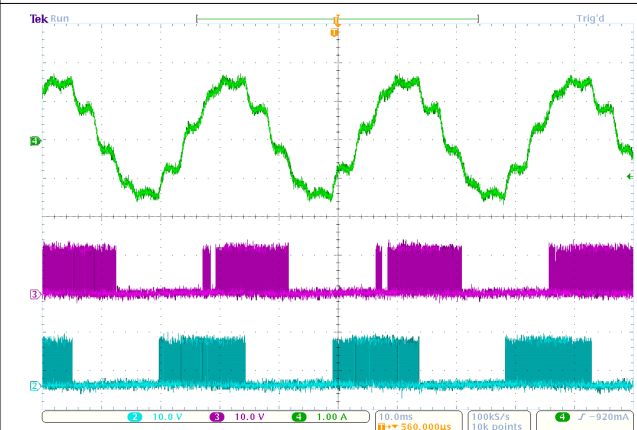

Figure 7-5. Stepper Control, Half Stepping, 12V

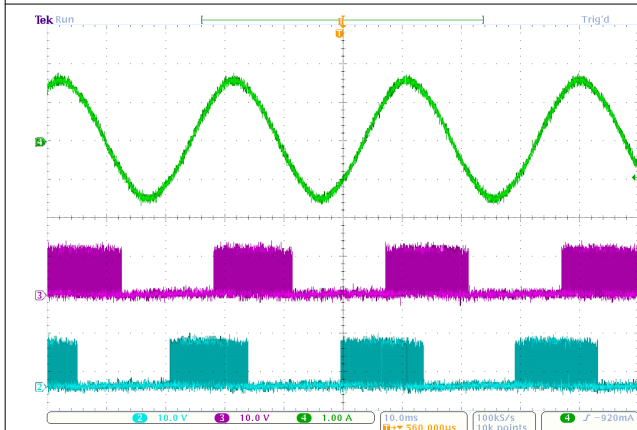

Figure 7-6. Stepper Control, 128 Microstepping, 12V

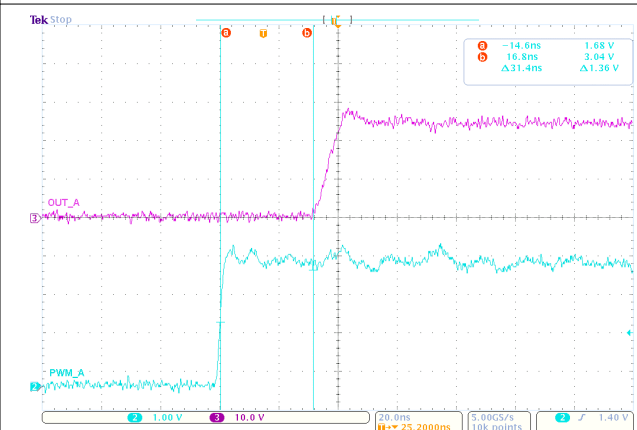
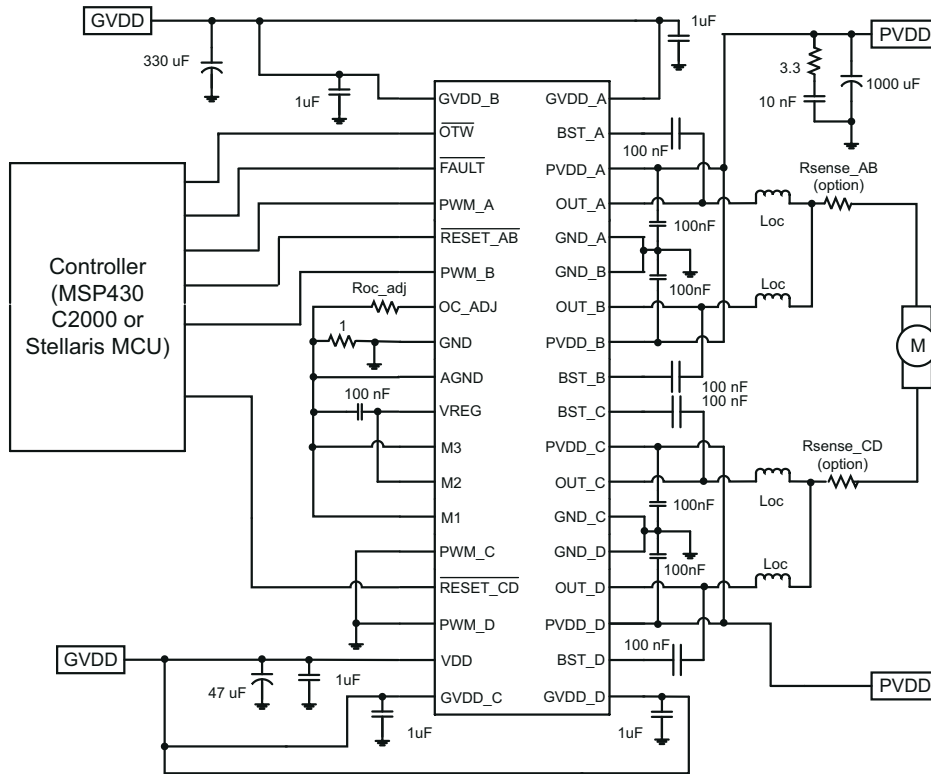

Figure 7-7. PWM_A to OUT_A

2.2 Parallel Full Bridge Mode Operation



PWM_A controls OUT_A and OUT_B; PWM_B controls OUT_C and OUT_D.

Figure 7-8. Application Diagram Example for Parallel Full Bridge Mode Operation Schematic

2.3 Stepper Motor Operation

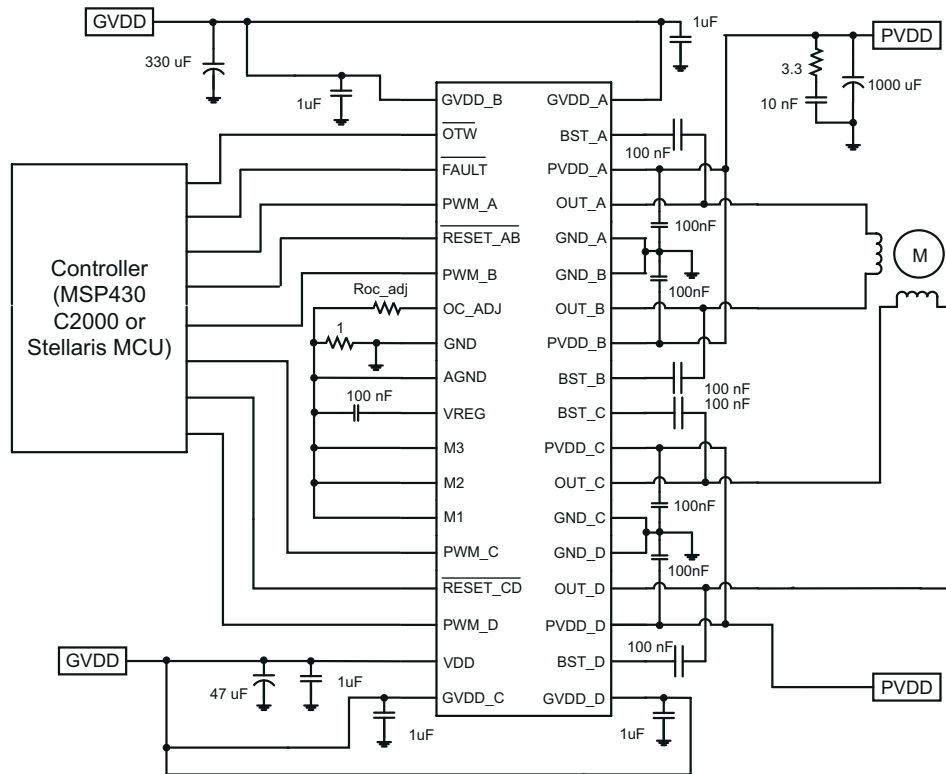

Figure 7-9. Application Diagram Example for Stepper Motor Operation Schematic

2.4 TEC Driver

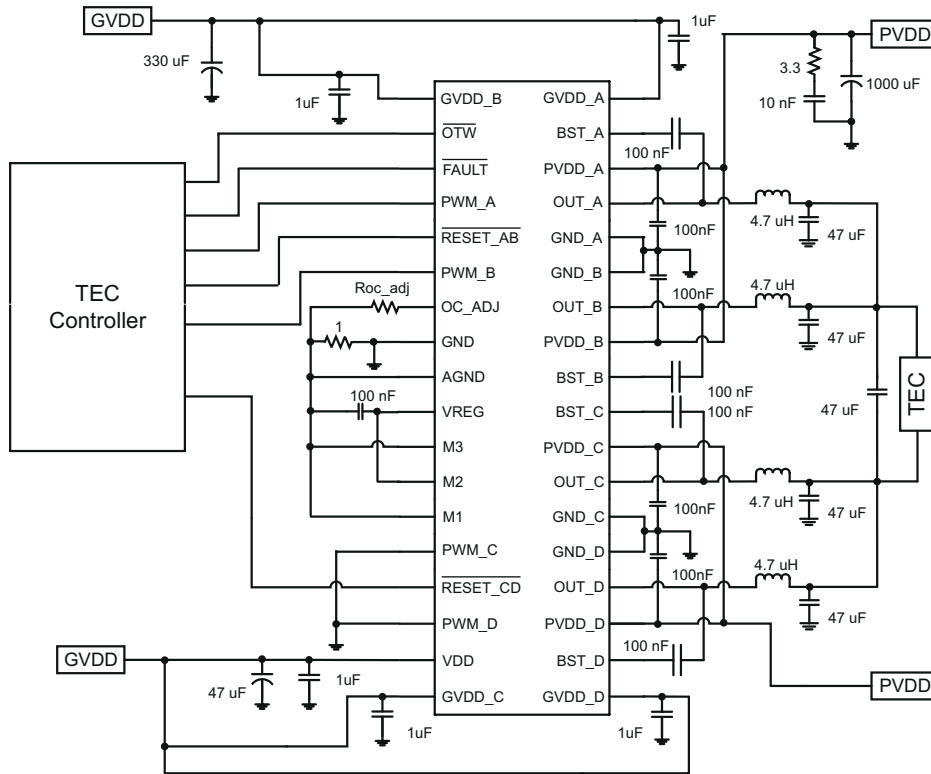

Figure 7-10. Application Diagram Example for TEC Driver Schematic

2.5 LED Lighting Driver

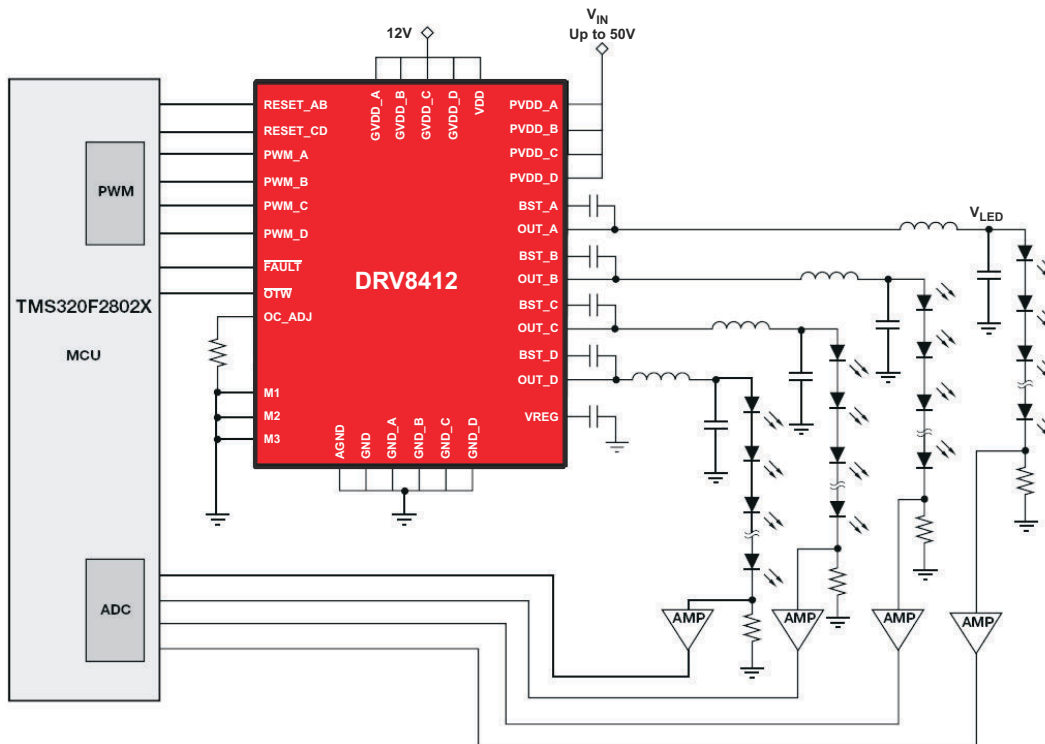

Figure 7-11. Application Diagram Example for LED Lighting Driver Schematic

3 Power Supply Recommendations

3.1 Bulk Capacitance

Having an appropriate local bulk capacitance is an important factor in motor drive system design. It is generally beneficial to have more bulk capacitance, while the disadvantages are increased cost and physical size.

The amount of local capacitance needed depends on a variety of factors, including:

- The highest current required by the motor system
- The power supply capacitance and ability to source current
- The amount of parasitic inductance between the power supply and motor system
- The acceptable voltage ripple
- The type of motor used (Brushed DC, Brushless DC, Stepper)
- The motor braking method

The inductance between the power supply and the motor drive system limits the rate current can change from the power supply. If the local bulk capacitance is too small, the system responds to excessive current demands or dumps from the motor with a change in voltage. When adequate bulk capacitance is used, the motor voltage remains stable and high current can be quickly supplied.

The data sheet provides a recommended value, but system-level testing is required to determine the appropriate sized bulk capacitor.

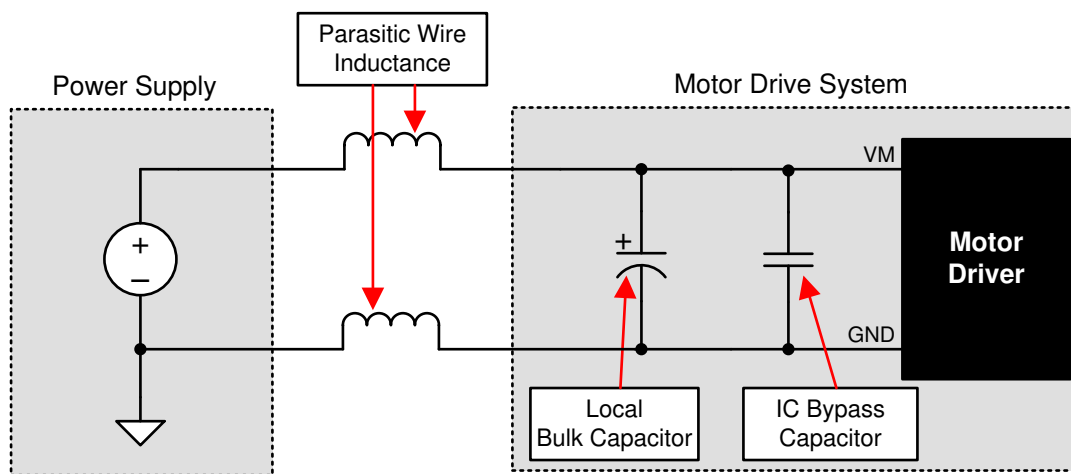

Figure 7-12. Example Setup of Motor Drive System With External Power Supply

The voltage rating for bulk capacitors should be higher than the operating voltage, to provide margin for cases when the motor transfers energy to the supply.

3.2 Power Supplies

To facilitate system design, the DRV841x2 needs only a 12V supply in addition to H-Bridge power supply (PVDD). An internal voltage regulator provides suitable voltage levels for the digital and low-voltage analog circuitry. Additionally, the high-side gate drive requires a floating voltage supply, which is accommodated by built-in bootstrap circuitry requiring external bootstrap capacitor.

To provide symmetrical electrical characteristics, the PWM signal path, including gate drive and output stage, is designed as identical, independent half-bridges. For this reason, each half-bridge has a separate gate drive supply (GVDD_X), a bootstrap pin (BST_X), and a power-stage supply pin (PVDD_X). Furthermore, an additional pin (VDD) is provided as supply for all common circuits. Special attention should be paid to place all decoupling capacitors as close to their associated pins as possible. In general, inductance between the power supply pins and decoupling capacitors must be avoided. Furthermore, decoupling capacitors need a short ground path back to the device.

For a properly functioning bootstrap circuit, a small ceramic capacitor (an X5R or better) must be connected from each bootstrap pin (BST_X) to the power-stage output pin (OUT_X). When the power-stage output is low, the bootstrap capacitor is charged through an internal diode connected between the gate-drive power-supply pin (GVDD_X) and the bootstrap pin. When the power-stage output is high, the bootstrap capacitor potential is shifted above the output potential and thus provides a suitable voltage supply for the high-side gate driver. In an application with PWM switching frequencies in the range from 10kHz to 500kHz, the use of 100-nF ceramic capacitors (X5R or better), size 0603 or 0805, is recommended for the bootstrap supply. These 100nF capacitors ensure sufficient energy storage, even during minimal PWM duty cycles, to keep the high-side power stage FET fully turned on during the remaining part of the PWM cycle. In an application running at a switching frequency lower than 10 kHz, the bootstrap capacitor might need to be increased in value.

Special attention should be paid to the power-stage power supply; this includes component selection, PCB placement, and routing. As indicated, each half-bridge has independent power-stage supply pin (PVDD_X). For optimal electrical performance, EMI compliance, and system reliability, it is important that each PVDD_X pin is decoupled with a ceramic capacitor (X5R or better) placed as close as possible to each supply pin. It is recommended to follow the PCB layout of the DRV841x2 EVM board.

The 12V supply should be from a low-noise, low-output-impedance voltage regulator. Likewise, the 50V power-stage supply is assumed to have low output impedance and low noise. The power-supply sequence is not critical as facilitated by the internal power-on-reset circuit. Moreover, the DRV841x2 is fully protected against erroneous power-stage turn-on due to parasitic gate charging. Thus, voltage-supply ramp rates (dv/dt) are non-critical within the specified voltage range (see [Section 5.3](#) of this data sheet).

3.3 System Power-Up and Power-Down Sequence

3.3.1 Powering Up

The DRV841x2 does not require a power-up sequence. The outputs of the H-bridges remain in a high impedance state until the gate-drive supply voltage GVDD_X and VDD voltage are above the undervoltage protection (UVP) voltage threshold (see the *Electrical Characteristics* section of this data sheet). Although not specifically required, holding $\overline{\text{RESET_AB}}$ and $\overline{\text{RESET_CD}}$ in a low state while powering up the device is recommended. This allows an internal circuit to charge the external bootstrap capacitors by enabling a weak pulldown of the half-bridge output.

3.3.2 Powering Down

The DRV841x2 does not require a power-down sequence. The device remains fully operational as long as the gate-drive supply (GVDD_X) voltage and VDD voltage are above the UVP voltage threshold (see the *Electrical Characteristics* section of this data sheet). Although not specifically required, it is a good practice to hold $\overline{\text{RESET_AB}}$ and $\overline{\text{RESET_CD}}$ low during power down to prevent any unknown state during this transition.

3.4 System Design Recommendations

3.4.1 VREG Pin

The VREG pin is used for internal logic and not recommended to be used as a voltage source for external circuitry.

3.4.2 VDD Pin

The transient current in VDD pin could be significantly higher than average current through that pin. A low resistive path to GVDD should be used. A 22 μ F to 47 μ F capacitor should be placed on VDD pin beside the 100nF to 1 μ F decoupling capacitor to provide a constant voltage during transient.

3.4.3 OTW Pin

$\overline{\text{OTW}}$ reporting indicates the device approaching high junction temperature. This signal can be used with MCU to decrease system power when $\overline{\text{OTW}}$ is low in order to prevent OT shut down at a higher temperature.

3.4.4 Mode Select Pin

Mode select pins (M1, M2, and M3) should be connected to either VREG (for logic high) or AGND for logic low. The recommendation is to not connect mode pins to board ground if 1 Ω resistor is used between AGND and GND.

3.4.5 Parallel Mode Operation

For a device operated in parallel mode, a minimum of 30 nH to 100 nH inductance or a ferrite bead is required after the output pins (for example, OUT_A and OUT_B) before connecting the two channels together. This helps to prevent any shoot through between two paralleled channels during switching transient due to mismatch of paralleled channels (for example, processor variation, unsymmetrical PCB layout, and so on).

3.4.6 TEC Driver Application

For TEC driver or other non-motor related applications (for example, resistive load or dc output), a low-pass LC filter can be used to meet the requirement.

4 Layout

4.1 Layout Guidelines

4.1.1 PCB Material Recommendation

FR-4 Glass Epoxy material with 2oz. copper on both top and bottom layer is recommended for improved thermal performance (better heat sinking) and less noise susceptibility (lower PCB trace inductance).

4.1.2 Ground Plane

Because of the power level of these devices, it is recommended to use a big unbroken single ground plane for the whole system / board. The ground plane can be easily made at bottom PCB layer. In order to minimize the impedance and inductance of ground traces, the traces from ground pins should keep as short and wide as possible before connected to bottom ground plane through vias. Multiple vias are suggested to reduce the impedance of vias. Try to clear the space around the device as much as possible especially at bottom PCB side to improve the heat spreading.

4.1.3 Decoupling Capacitor

High frequency decoupling capacitors (100 nF) on PVDD_X pins should be placed close to these pins and with a short ground return path to minimize the inductance on the PCB trace.

4.1.4 AGND

AGND is a localized internal ground for logic signals. A 1 Ω resistor is recommended to be connected between GND and AGND to isolate the noise from board ground to AGND. There are other two components are connected to this local ground: 0.1 μ F capacitor between VREG to AGND and Roc_adj resistor between OC_ADJ and AGND. Capacitor for VREG should be placed close to VREG and AGND pin and connected without vias.

4.2 Layout Example

4.2.1 Current Shunt Resistor

If current shunt resistor is connected between GND_X to GND or PVDD_X to PVDD, make sure there is only one single path to connect each GND_X or PVDD_X pin to shunt resistor, and the path is short and symmetrical on each sense path to minimize the measurement error due to additional resistance on the trace.

An example of the schematic and PCB layout of DRV8412 are shown in [Figure 7-13](#), [Figure 7-14](#), and [Figure 7-15](#).

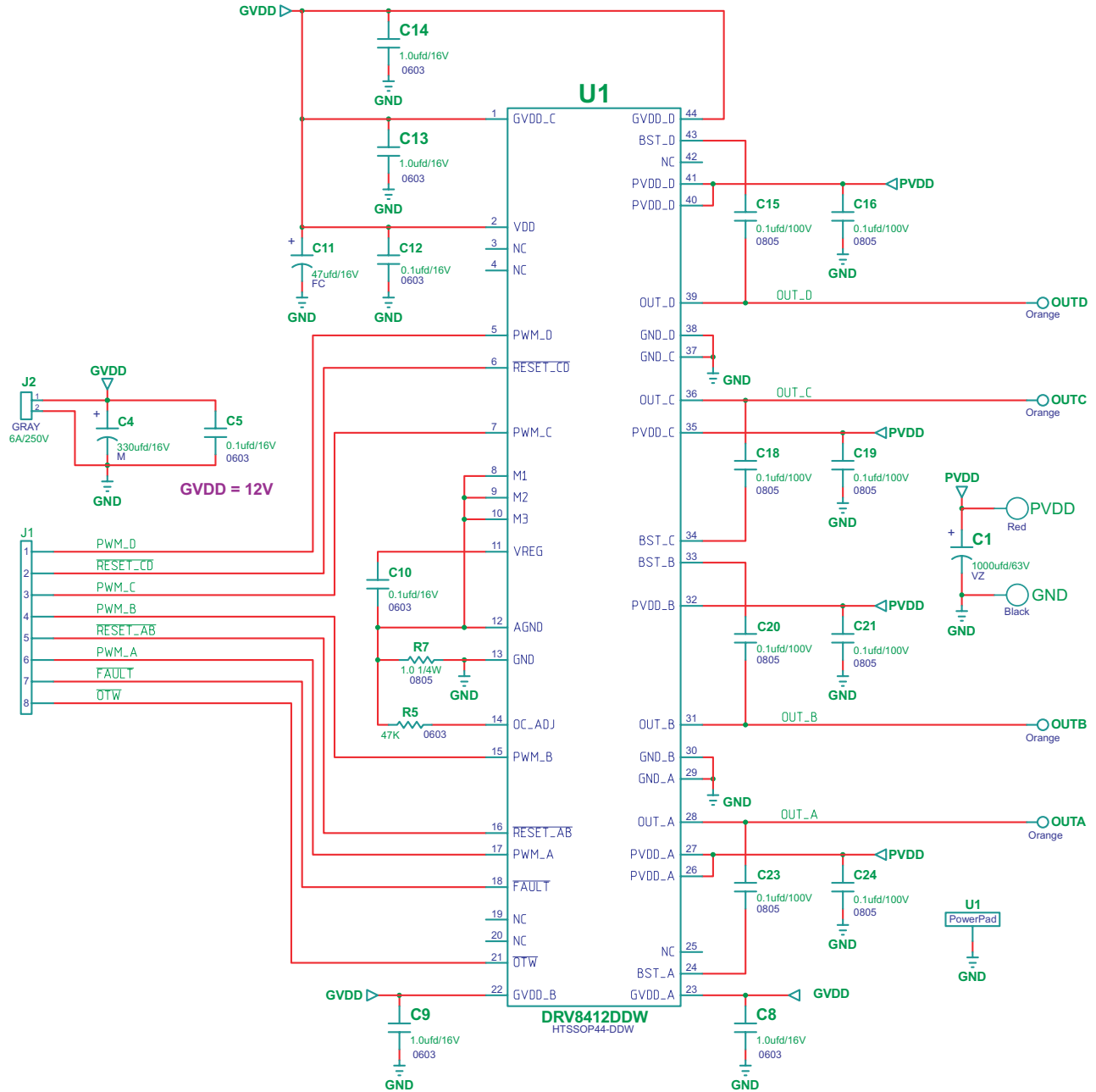
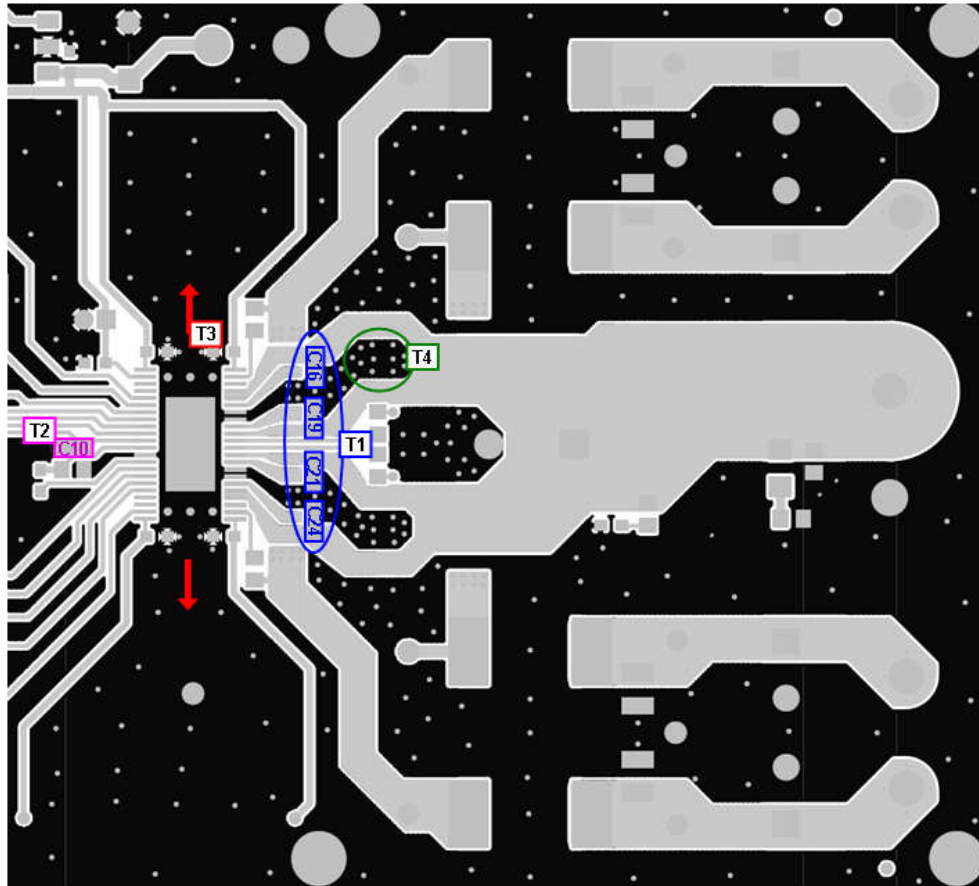

Figure 7-13. DRV8412 Schematic Example



T1: PVDD decoupling capacitors C16, C19, C21, and C24 should be placed very close to PVDD_X pins and ground return path.

T2: VREG decoupling capacitor C10 should be placed very close to VREG and AGND pins.

T3: Clear the space above and below the device as much as possible to improve the thermal spreading.

T4: Add many vias to reduce the impedance of ground path through top to bottom side. Make traces as wide as possible for ground path such as GND_X path.

Figure 7-14. Printed Circuit Board – Top Layer

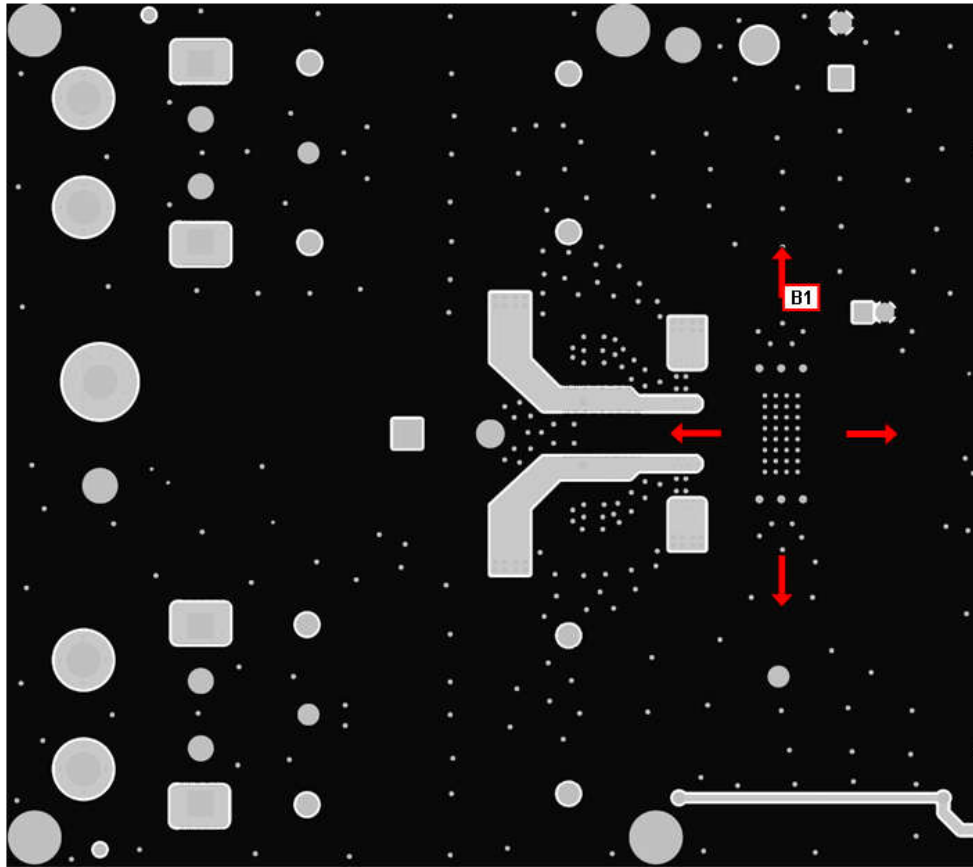

B1: Do not block the heat transfer path at bottom side. Clear as much space as possible for better heat spreading.

Figure 7-15. Printed Circuit Board – Bottom Layer

4.3 Thermal Considerations

The thermally enhanced package provided with the DRV8432 is designed to interface directly to heat sink using a thermal interface compound, (for example, Ceramique from Arctic Silver, TIMTronics 413, and so on). The heat sink then absorbs heat from the ICs and couples to the local air. A good practice is to connect the heatsink to system ground on the PCB board to reduce the ground noise.

$R_{\theta JA}$ is a system thermal resistance from junction to ambient air. The system parameters have the following components:

- $R_{\theta JC}$ (the thermal resistance from junction to case, or in this example the power pad or heat slug)
- Thermal grease thermal resistance
- Heat sink thermal resistance

The thermal grease thermal resistance can be calculated from the exposed power pad or heat slug area and the thermal grease manufacturer's area thermal resistance (expressed in °C-in²/W or °C-mm²/W). The approximate exposed heat slug size is as follows:

- DRV8432, 36-pin PSOP3 0.124 in² (80mm²)

The thermal resistance of thermal pads is considered higher than a thin thermal grease layer and is not recommended. Thermal tape has an even higher thermal resistance and should not be used at all. Heat sink thermal resistance is predicted by the heat sink vendor, modeled using a continuous flow dynamics (CFD) model, or measured.

Thus the system $R_{\theta JA} = R_{\theta JC} + \text{thermal grease resistance} + \text{heat sink resistance}$.

See the TI application report, *IC Package Thermal Metrics* (SPRA953), for more thermal information.

4.3.1 DRV8412 Thermal Via Design Recommendation

Thermal pad of the DRV8412 is attached at bottom of device to improve the thermal capability of the device. The thermal pad has to be soldered with a very good coverage on PCB to deliver the power specified in the data sheet. Figure 7-16 shows the recommended thermal via and land pattern design for the DRV8412. For additional information, see TI application report, PowerPad™ Made Easy (SLMA004) and PowerPad Layout Guidelines (SOLA120).

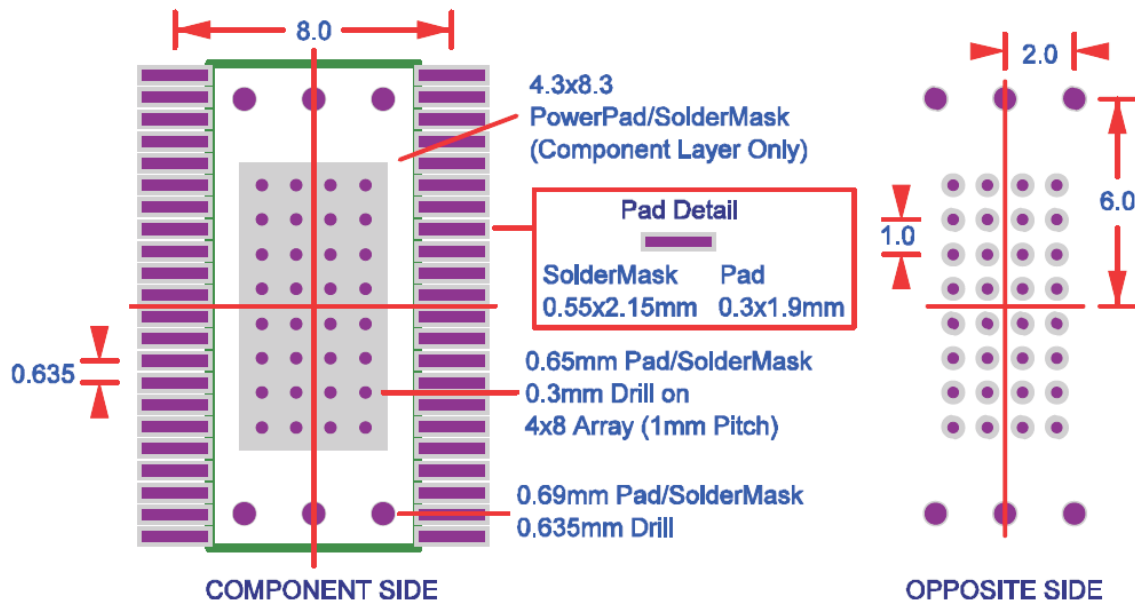

Figure 7-16. DRV8412 Thermal Via Footprint

7 Device and Documentation Support

7.1 Receiving Notification of Documentation Updates

To receive notification of documentation updates, navigate to the device product folder on ti.com. Click on *Notifications* to register and receive a weekly digest of any product information that has changed. For change details, review the revision history included in any revised document.

7.2 Support Resources

[TI E2E™ support forums](#) are an engineer's go-to source for fast, verified answers and design help — straight from the experts. Search existing answers or ask your own question to get the quick design help you need.

Linked content is provided "AS IS" by the respective contributors. They do not constitute TI specifications and do not necessarily reflect TI's views; see TI's [Terms of Use](#).

7.3 Trademarks

PowerPad™ and TI E2E™ are trademarks of Texas Instruments. All trademarks are the property of their respective owners.

7.4 Electrostatic Discharge Caution



This integrated circuit can be damaged by ESD. Texas Instruments recommends that all integrated circuits be handled with appropriate precautions. Failure to observe proper handling and installation procedures can cause damage.

ESD damage can range from subtle performance degradation to complete device failure. Precision integrated circuits may be more susceptible to damage because very small parametric changes could cause the device not to meet its published specifications.

7.5 Glossary

[TI Glossary](#) This glossary lists and explains terms, acronyms, and definitions.

8 Revision History

NOTE: Page numbers for previous revisions may differ from page numbers in the current version.

Changes from Revision G (July 2014) to Revision H (July 2024)	Page
• Changed the Device Information table to the <i>Package Information</i> table.....	1
• Deleted values in 39 to 200 in Table 6-2	12

Changes from Revision F (January 2014) to Revision G (July 2014)	Page
• Added <i>ESD Rating</i> table, <i>Feature Description</i> section, <i>Device Functional Modes, Application and Implementation</i> section, <i>Power Supply Recommendations</i> section, <i>Layout</i> section, <i>Device and Documentation Support</i> section, and <i>Mechanical, Packaging, and Orderable Information</i> section	1

Changes from Revision E (October 2013) to Revision F (January 2014)	Page
• Changed GND_A, GND_B, GND_C, and GND_D pins description to remove text "requires close decoupling capacitor to ground".....	3
• Changed the t _{ON_MIN} description to include "for charging the Bootstrap capacitor".....	5
• Added text to the Overcurrent (OC) Protection section - "It is important to note..."	12

Changes from Revision D (July 2011) to Revision E (October 2013)	Page
• Added last sentence in description of Thermal Pad in Pin Functions table.....	3
• Added THERMAL INFORMATION table.....	6

- Added a new paragraph in DIFFERENT OPERATIONAL MODES section: In operation modes.....DC logic level..... 14

Changes from Revision C (May 2010) to Revision D (July 2011) Page

- Changed from 80mΩ to 110mΩ in first Feature..... 1
- Changed from 50V to 52V in second Feature..... 1
- Deleted (70V Absolute Maximum) from second Feature..... 1
- Added LED Lighting Drivers to Applications..... 1
- Added Includes metallization bond wire and pin resistance to R_{DS(on)} test conditions..... 7
- Changed R_{DS(on)} typ from 80 mΩ to 110 mΩ..... 7
- Added text to 5th paragraph of Overcurrent (OC) Protection section..... 12
- Deleted Output Inductor Selection section and moved information into Overcurrent (OC) Protection section..... 12
- Changed [Figure 7-1](#) 16
- Changed [Figure 7-9](#) 20
- Deleted Application Diagram Example for Three Phase PMSM PVDD Sense Operation and Application Diagram Example for Three Phase PMSM GND Sense Operation figures..... 21
- Added [Figure 7-11](#) 21
- Changed [Figure 7-13](#) 24

Changes from Revision B (Jan 2010) to Revision C () Page

- Deleted all DRV8422 related descriptions from this data sheet..... 1
- Changed the DRV8432 pinout..... 3
- Added Thermal Pad and Heat slug rows to end of Pin Functions table. Also added T=thermal in note..... 3
- Added second paragraph to Bootstrap Capacitor....section..... 11
- Deleted or GVDD undervoltage from DEVICE RESET section second paragraph..... 13

Changes from Revision A (December 2009) to Revision B () Page

- Added T_A = 125°C power rating of 1.0 W to package power deratings table..... 6

9 Mechanical, Packaging, and Orderable Information

The following pages include mechanical, packaging, and orderable information. This information is the most current data available for the designated devices. This data is subject to change without notice and revision of this document. For browser-based versions of this data sheet, refer to the left-hand navigation.

PACKAGING INFORMATION

Orderable part number	Status (1)	Material type (2)	Package Pins	Package qty Carrier	RoHS (3)	Lead finish/ Ball material (4)	MSL rating/ Peak reflow (5)	Op temp (°C)	Part marking (6)
DRV8412DDWR	Active	Production	HTSSOP (DDW) 44	2000 LARGE T&R	Yes	NIPDAU	Level-3-260C-168 HR	-40 to 85	DRV8412
DRV8412DDWR.A	Active	Production	HTSSOP (DDW) 44	2000 LARGE T&R	Yes	NIPDAU	Level-3-260C-168 HR	-40 to 85	DRV8412
DRV8412DDWR.B	Active	Production	HTSSOP (DDW) 44	2000 LARGE T&R	Yes	NIPDAU	Level-3-260C-168 HR	-40 to 85	DRV8412
DRV8412DDWRG4	Active	Production	HTSSOP (DDW) 44	2000 LARGE T&R	Yes	NIPDAU	Level-3-260C-168 HR	-40 to 85	DRV8412
DRV8412DDWRG4.A	Active	Production	HTSSOP (DDW) 44	2000 LARGE T&R	Yes	NIPDAU	Level-3-260C-168 HR	-40 to 85	DRV8412
DRV8412DDWRG4.B	Active	Production	HTSSOP (DDW) 44	2000 LARGE T&R	Yes	NIPDAU	Level-3-260C-168 HR	-40 to 85	DRV8412

(1) **Status:** For more details on status, see our [product life cycle](#).

(2) **Material type:** When designated, preproduction parts are prototypes/experimental devices, and are not yet approved or released for full production. Testing and final process, including without limitation quality assurance, reliability performance testing, and/or process qualification, may not yet be complete, and this item is subject to further changes or possible discontinuation. If available for ordering, purchases will be subject to an additional waiver at checkout, and are intended for early internal evaluation purposes only. These items are sold without warranties of any kind.

(3) **RoHS values:** Yes, No, RoHS Exempt. See the [TI RoHS Statement](#) for additional information and value definition.

(4) **Lead finish/Ball material:** Parts may have multiple material finish options. Finish options are separated by a vertical ruled line. Lead finish/Ball material values may wrap to two lines if the finish value exceeds the maximum column width.

(5) **MSL rating/Peak reflow:** The moisture sensitivity level ratings and peak solder (reflow) temperatures. In the event that a part has multiple moisture sensitivity ratings, only the lowest level per JEDEC standards is shown. Refer to the shipping label for the actual reflow temperature that will be used to mount the part to the printed circuit board.

(6) **Part marking:** There may be an additional marking, which relates to the logo, the lot trace code information, or the environmental category of the part.

Multiple part markings will be inside parentheses. Only one part marking contained in parentheses and separated by a "~" will appear on a part. If a line is indented then it is a continuation of the previous line and the two combined represent the entire part marking for that device.

Important Information and Disclaimer: The information provided on this page represents TI's knowledge and belief as of the date that it is provided. TI bases its knowledge and belief on information provided by third parties, and makes no representation or warranty as to the accuracy of such information. Efforts are underway to better integrate information from third parties. TI has taken and continues to take reasonable steps to provide representative and accurate information but may not have conducted destructive testing or chemical analysis on incoming materials and chemicals. TI and TI suppliers consider certain information to be proprietary, and thus CAS numbers and other limited information may not be available for release.

In no event shall TI's liability arising out of such information exceed the total purchase price of the TI part(s) at issue in this document sold by TI to Customer on an annual basis.

TAPE AND REEL INFORMATION

QUADRANT ASSIGNMENTS FOR PIN 1 ORIENTATION IN TAPE

*All dimensions are nominal

Device	Package Type	Package Drawing	Pins	SPQ	Reel Diameter (mm)	Reel Width W1 (mm)	A0 (mm)	B0 (mm)	K0 (mm)	P1 (mm)	W (mm)	Pin1 Quadrant
DRV8412DDWR	HTSSOP	DDW	44	2000	330.0	24.4	8.6	15.6	1.8	12.0	24.0	Q1
DRV8412DDWRG4	HTSSOP	DDW	44	2000	330.0	24.4	8.6	15.6	1.8	12.0	24.0	Q1

TAPE AND REEL BOX DIMENSIONS

*All dimensions are nominal

Device	Package Type	Package Drawing	Pins	SPQ	Length (mm)	Width (mm)	Height (mm)
DRV8412DDWR	HTSSOP	DDW	44	2000	350.0	350.0	43.0
DRV8412DDWRG4	HTSSOP	DDW	44	2000	350.0	350.0	43.0

GENERIC PACKAGE VIEW

DDW 44

PowerPAD TSSOP - 1.2 mm max height

6.1 x 14, 0.635 mm pitch

PLASTIC SMALL OUTLINE

This image is a representation of the package family, actual package may vary.
Refer to the product data sheet for package details.

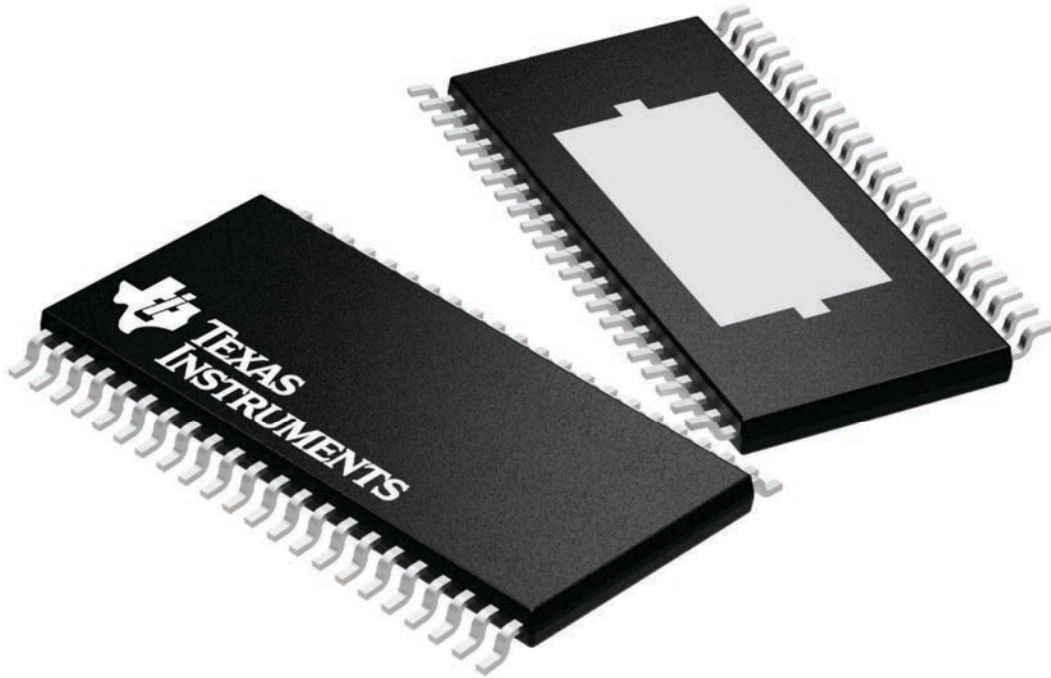

4224876/A

DDW0044B

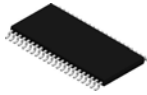

PACKAGE OUTLINE

PowerPAD™ TSSOP - 1.2 mm max height

PLASTIC SMALL OUTLINE

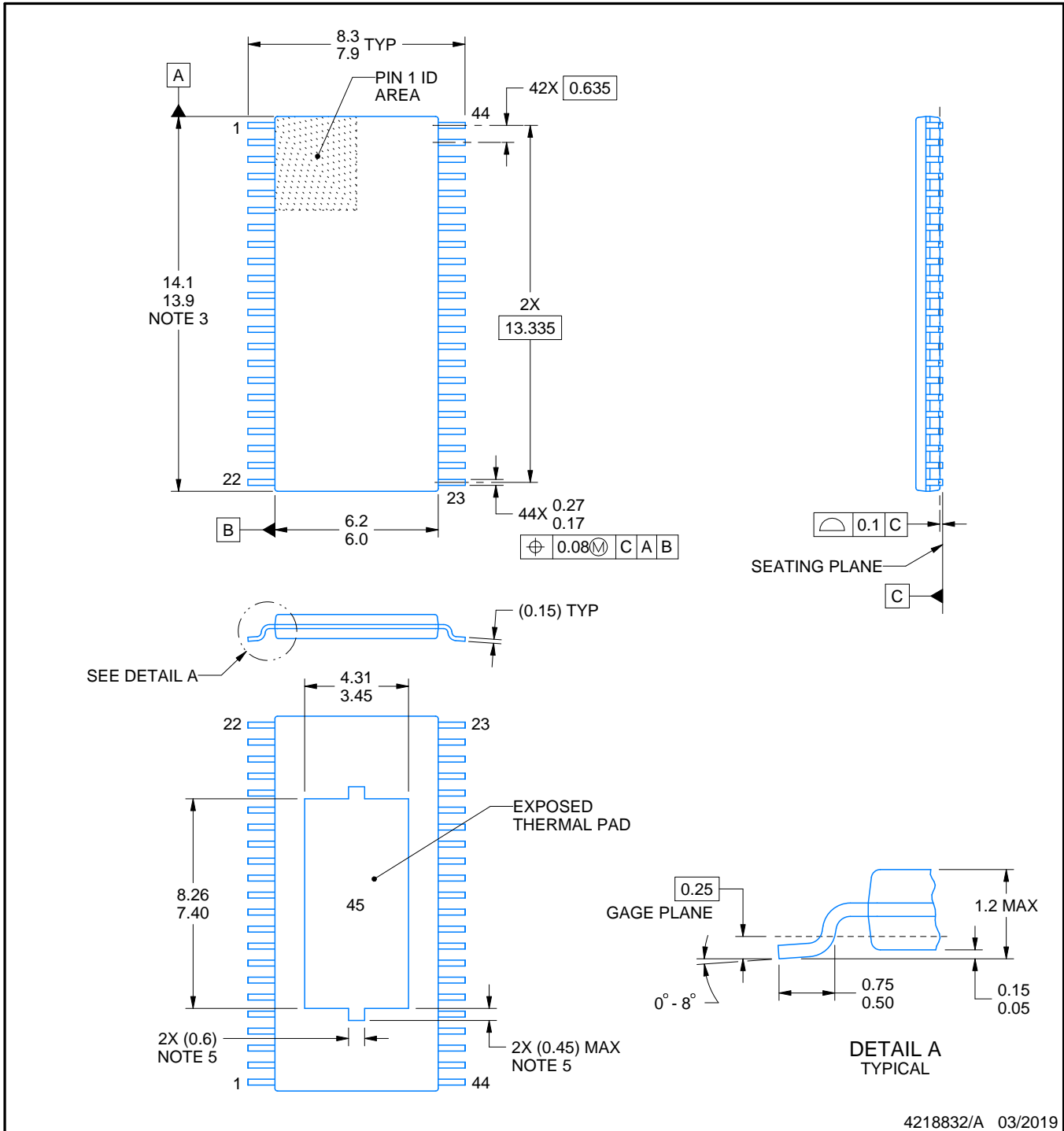

4218832/A 03/2019

NOTES:

PowerPAD is a trademark of Texas Instruments.

1. All linear dimensions are in millimeters. Any dimensions in parenthesis are for reference only. Dimensioning and tolerancing per ASME Y14.5M.
2. This drawing is subject to change without notice.
3. This dimension does not include mold flash, protrusions, or gate burrs. Mold flash, protrusions, or gate burrs shall not exceed 0.15 mm per side.
4. Features may differ or may not be present.

EXAMPLE BOARD LAYOUT

DDW0044B

PowerPAD™ TSSOP - 1.2 mm max height

PLASTIC SMALL OUTLINE

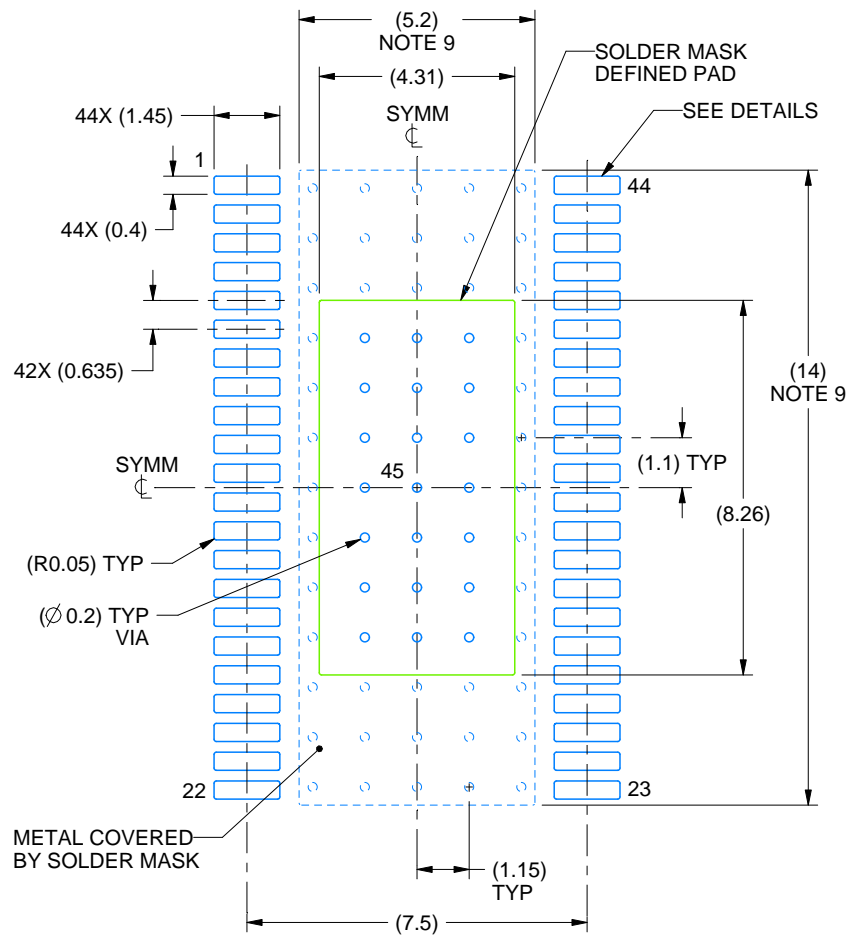

LAND PATTERN EXAMPLE
SCALE:6X

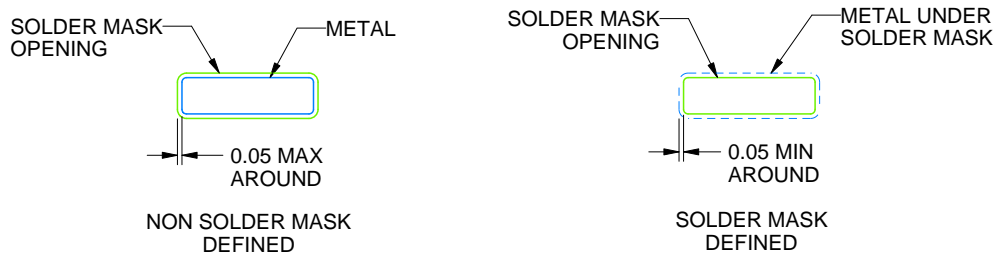

SOLDER MASK DETAILS
NOT TO SCALE

4218832/A 03/2019

NOTES: (continued)

- 5. Publication IPC-7351 may have alternate designs.
- 6. Solder mask tolerances between and around signal pads can vary based on board fabrication site.
- 7. This package is designed to be soldered to a thermal pad on the board. For more information, see Texas Instruments literature numbers SLMA002 (www.ti.com/lit/slma002) and SLMA004 (www.ti.com/lit/slma004).
- 8. Size of metal pad may vary due to creepage requirement.

EXAMPLE STENCIL DESIGN

DDW0044B

PowerPAD™ TSSOP - 1.2 mm max height

PLASTIC SMALL OUTLINE

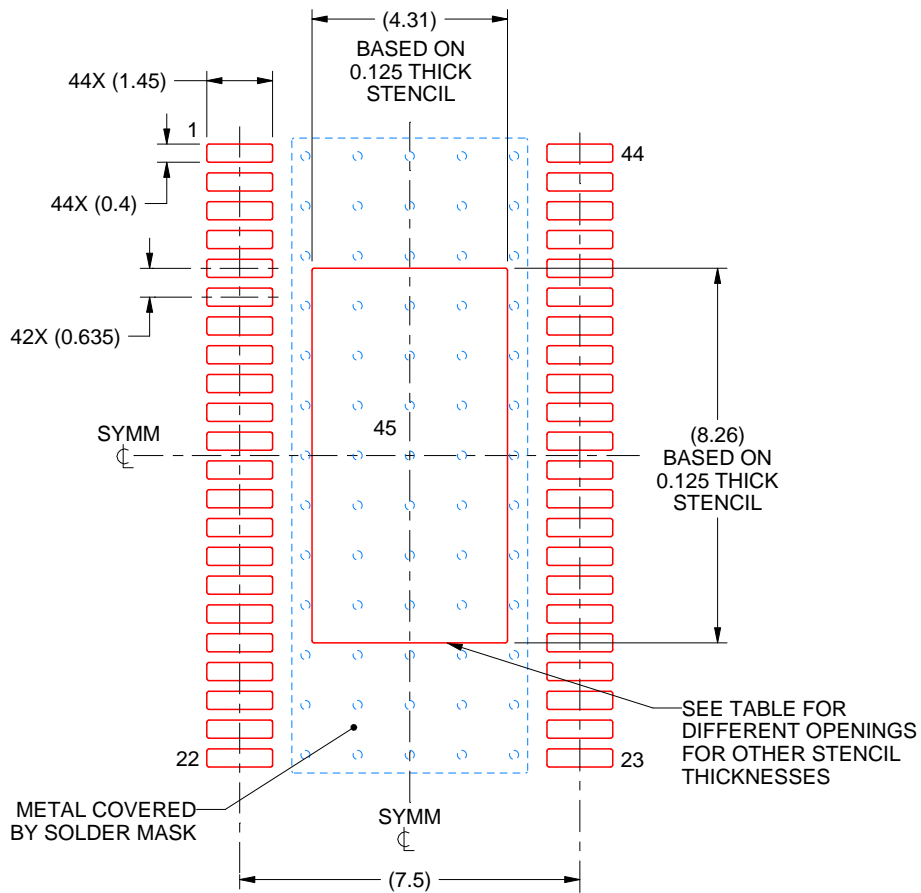

SOLDER PASTE EXAMPLE
 PAD 45:
 100% PRINTED SOLDER COVERAGE BY AREA
 SCALE:6X

STENCIL THICKNESS	SOLDER STENCIL OPENING
0.1	4.82 X 9.23
0.125	4.31 X 8.26 (SHOWN)
0.15	3.93 X 7.54
0.175	3.64 X 6.98

4218832/A 03/2019

NOTES: (continued)

9. Laser cutting apertures with trapezoidal walls and rounded corners may offer better paste release. IPC-7525 may have alternate design recommendations.
10. Board assembly site may have different recommendations for stencil design.

IMPORTANT NOTICE AND DISCLAIMER

TI PROVIDES TECHNICAL AND RELIABILITY DATA (INCLUDING DATASHEETS), DESIGN RESOURCES (INCLUDING REFERENCE DESIGNS), APPLICATION OR OTHER DESIGN ADVICE, WEB TOOLS, SAFETY INFORMATION, AND OTHER RESOURCES "AS IS" AND WITH ALL FAULTS, AND DISCLAIMS ALL WARRANTIES, EXPRESS AND IMPLIED, INCLUDING WITHOUT LIMITATION ANY IMPLIED WARRANTIES OF MERCHANTABILITY, FITNESS FOR A PARTICULAR PURPOSE OR NON-INFRINGEMENT OF THIRD PARTY INTELLECTUAL PROPERTY RIGHTS.

These resources are intended for skilled developers designing with TI products. You are solely responsible for (1) selecting the appropriate TI products for your application, (2) designing, validating and testing your application, and (3) ensuring your application meets applicable standards, and any other safety, security, regulatory or other requirements.

These resources are subject to change without notice. TI grants you permission to use these resources only for development of an application that uses the TI products described in the resource. Other reproduction and display of these resources is prohibited. No license is granted to any other TI intellectual property right or to any third party intellectual property right. TI disclaims responsibility for, and you fully indemnify TI and its representatives against any claims, damages, costs, losses, and liabilities arising out of your use of these resources.

TI's products are provided subject to [TI's Terms of Sale](#), [TI's General Quality Guidelines](#), or other applicable terms available either on [ti.com](#) or provided in conjunction with such TI products. TI's provision of these resources does not expand or otherwise alter TI's applicable warranties or warranty disclaimers for TI products. Unless TI explicitly designates a product as custom or customer-specified, TI products are standard, catalog, general purpose devices.

TI objects to and rejects any additional or different terms you may propose.

Copyright © 2025, Texas Instruments Incorporated

Last updated 10/2025