

DRV8839 Low-Voltage Dual ½-H-Bridge Driver IC

1 Features

- Dual ½-H-Bridge Motor Driver
 - Drives a DC Motor or One Winding of a Stepper Motor, or Other Loads
 - Low MOSFET ON-Resistance: HS + LS 280 mΩ
- 1.8-A Maximum Drive Current
- Separate Motor and Logic Supply Pins:
 - 0-V to 11-V Motor-Operating Supply-Voltage
 - 1.8-V to 7-V Logic Supply-Voltage
- Individual ½-H-Bridge Control Input Interface
- Low-Power Sleep Mode With 120-nA Maximum Combined Supply Current
- 2.00-mm × 3.00-mm 12-Pin WSON Package

2 Applications

- Battery-Powered:
 - DSLR Lenses
 - Consumer Products
 - Toys
 - Robotics
 - Cameras
 - Medical Devices

3 Description

The DRV8839 provides a versatile power driver solution for cameras, consumer products, toys, and other low-voltage or battery-powered applications. The device has two independent ½-H-bridge drivers and can drive one DC motor or one winding of a stepper motor, as well as other devices like solenoids. The output stages use N-channel power MOSFETs configured as ½-H-bridges. An internal charge pump generates needed gate-drive voltages.

The DRV8839 can supply up to 1.8-A of output current. It operates on a motor power supply voltage from 0 V to 11 V and a device power supply voltage of 1.8 V to 7 V.

The DRV8839 has independent input and enable pins for each ½-H-bridge which allow independent control of each output.

Internal shutdown functions are provided for overcurrent protection, short-circuit protection, undervoltage lockout, and overtemperature.

The DRV8839 is packaged in a 12-pin, 2.00-mm × 3.00-mm WSON package (Eco-friendly: RoHS and no Sb/Br).

Device Information⁽¹⁾

| PART NUMBER | PACKAGE | BODY SIZE (NOM) |
|-------------|-----------|-------------------|
| DRV8839 | WSON (12) | 2.00 mm × 3.00 mm |

(1) For all available packages, see the Orderable Addendum at the end of the data sheet.

Simplified Schematic

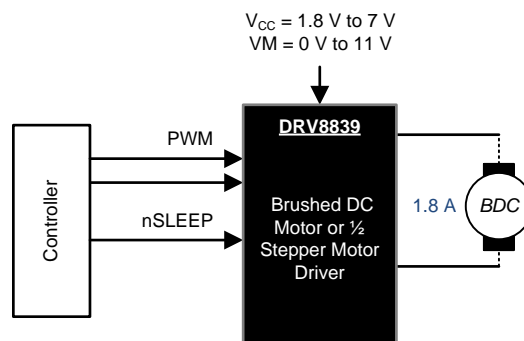

Copyright © 2016, Texas Instruments Incorporated



Table of Contents

| | | | | | |
|----------|--|----------|-----------|---|-----------|
| 1 | Features | 1 | 8 | Application and Implementation | 12 |
| 2 | Applications | 1 | 8.1 | Application Information..... | 12 |
| 3 | Description | 1 | 8.2 | Typical Application | 12 |
| 4 | Revision History | 2 | 9 | Power Supply Recommendations | 14 |
| 5 | Pin Configuration and Functions | 3 | 9.1 | Bulk Capacitance | 14 |
| 6 | Specifications | 4 | 10 | Layout | 15 |
| 6.1 | Absolute Maximum Ratings | 4 | 10.1 | Layout Guidelines | 15 |
| 6.2 | ESD Ratings..... | 4 | 10.2 | Layout Example | 15 |
| 6.3 | Recommended Operating Conditions..... | 4 | 10.3 | Thermal Considerations | 15 |
| 6.4 | Thermal Information | 4 | 11 | Device and Documentation Support | 17 |
| 6.5 | Electrical Characteristics..... | 5 | 11.1 | Documentation Support | 17 |
| 6.6 | Timing Requirements | 5 | 11.2 | Receiving Notification of Documentation Updates | 17 |
| 6.7 | Typical Characteristics | 7 | 11.3 | Community Resources..... | 17 |
| 7 | Detailed Description | 8 | 11.4 | Trademarks | 17 |
| 7.1 | Overview | 8 | 11.5 | Electrostatic Discharge Caution..... | 17 |
| 7.2 | Functional Block Diagram | 8 | 11.6 | Glossary | 17 |
| 7.3 | Feature Description..... | 9 | 12 | Mechanical, Packaging, and Orderable Information | 17 |
| 7.4 | Device Functional Modes..... | 9 | | | |

4 Revision History

NOTE: Page numbers for previous revisions may differ from page numbers in the current version.

| Changes from Revision B (December 2015) to Revision C | Page |
|---|-------------|
| • Deleted nFAULT from the <i>Simplified Schematic</i> | 1 |
| • Deleted the NC pins from the <i>Pin Functions</i> table | 3 |
| • Changed the value of the capacitor on the VM pin from 10 μ F to 0.1 μ F in the <i>Typical Application Schematic</i> | 12 |
| • Changed the <i>Layout Guidelines</i> to clarify the guidelines for the VM pin..... | 15 |
| • Deleted references to TI's PowerPAD package and updated it with thermal pad where applicable | 16 |
| • Added the <i>Receiving Notification of Documentation Updates</i> section | 17 |

| Changes from Revision A (January 2014) to Revision B | Page |
|--|-------------|
| • Added <i>ESD Ratings</i> table, <i>Feature Description</i> section, <i>Device Functional Modes</i> , <i>Application and Implementation</i> section, <i>Power Supply Recommendations</i> section, <i>Layout</i> section, <i>Device and Documentation Support</i> section, and <i>Mechanical, Packaging, and Orderable Information</i> section | 1 |

| Changes from Original (January 2013) to Revision A | Page |
|---|-------------|
| • Changed <i>Features</i> bullet | 1 |
| • Changed motor supply voltage range in <i>Description</i> section | 1 |
| • Changed Motor power supply voltage range in <i>Recommended Operating Conditions</i> | 4 |
| • Added t_{OCR} and t_{DEAD} parameters to <i>Electrical Characteristics</i> | 5 |
| • Added paragraph to <i>Power Supplies</i> and <i>Input Pins</i> section | 14 |

5 Pin Configuration and Functions

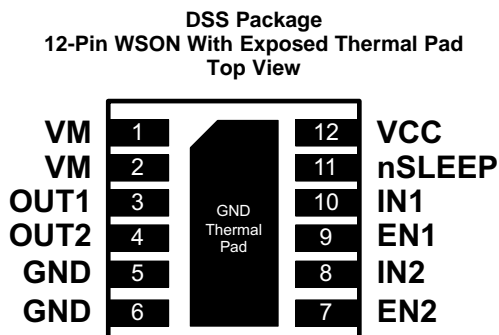

Pin Functions

| PIN | | I/O ⁽¹⁾ | DESCRIPTION | EXTERNAL COMPONENTS OR CONNECTIONS |
|-------------------------|------|--------------------|------------------|--|
| NAME | NO. | | | |
| POWER AND GROUND | | | | |
| GND, Thermal pad | 5, 6 | — | Device ground | |
| VCC | 12 | — | Device supply | Bypass to GND with a 0.1- μ F, 6.3-V ceramic capacitor |
| VM | 1, 2 | — | Motor supply | Bypass to GND with a 0.1- μ F, 16-V ceramic capacitor |
| CONTROL | | | | |
| EN1 | 9 | I | Enable 1 | Logic high enables OUT1 Internal pulldown resistor |
| EN2 | 7 | I | Enable 2 | Logic high enables OUT2 Internal pulldown resistor |
| IN1 | 10 | I | Input 1 | Logic input controls OUT1 Internal pulldown resistor |
| IN2 | 8 | I | Input 2 | Logic input controls OUT2 Internal pulldown resistor |
| nSLEEP | 11 | I | Sleep mode input | Logic low puts device in low-power sleep mode Logic high for normal operation Internal pulldown resistor |
| OUTPUT | | | | |
| OUT1 | 3 | O | Output 1 | Connect to motor winding |
| OUT2 | 4 | O | Output 2 | |

(1) Directions: I = input, O = output, OZ = tri-state output, OD = open-drain output, IO = input/output.

6 Specifications

6.1 Absolute Maximum Ratings

Over operating free-air temperature range (unless otherwise noted)⁽¹⁾⁽²⁾

| | MIN | MAX | UNIT |
|---|--------------------|-----|------|
| Power supply voltage, VM | -0.3 | 12 | V |
| Power supply voltage, VCC | -0.3 | 7 | V |
| Digital input pin voltage | -0.5 | 7 | V |
| Peak motor drive output current | Internally limited | | A |
| T _J Operating junction temperature | -40 | 150 | °C |
| T _{stg} Storage temperature | -60 | 150 | °C |

- (1) Stresses beyond those listed under *Absolute Maximum Ratings* may cause permanent damage to the device. These are stress ratings only, which do not imply functional operation of the device at these or any other conditions beyond those indicated under *Recommended Operating Conditions*. Exposure to absolute-maximum-rated conditions for extended periods may affect device reliability.
- (2) All voltage values are with respect to network ground terminal.

6.2 ESD Ratings

| | | VALUE | UNIT |
|--|--|-------|------|
| V _(ESD) Electrostatic discharge | Human-body model (HBM), per ANSI/ESDA/JEDEC JS-001 ⁽¹⁾ | ±4000 | V |
| | Charged-device model (CDM), per JEDEC specification JESD22-C101 ⁽²⁾ | ±1500 | |

- (1) JEDEC document JEP155 states that 500-V HBM allows safe manufacturing with a standard ESD control process.
- (2) JEDEC document JEP157 states that 250-V CDM allows safe manufacturing with a standard ESD control process.

6.3 Recommended Operating Conditions

T_A = 25°C (unless otherwise noted)

| | MIN | NOM | MAX | UNIT |
|---|-----|-----|-----|------|
| V _{CC} Device power supply voltage | 1.8 | | 7 | V |
| V _M Motor power supply voltage | 0 | | 11 | V |
| V _{IN} Logic level input voltage | 0 | | 5.5 | V |
| I _{OUT} H-bridge output current ⁽¹⁾ | 0 | | 1.8 | A |
| f _{PWM} Externally applied PWM frequency | 0 | | 250 | kHz |

- (1) Power dissipation and thermal limits must be observed.

6.4 Thermal Information

| THERMAL METRIC ⁽¹⁾ | | DRV8839 | UNIT |
|-------------------------------|--|------------|------|
| | | DSS (WSON) | |
| | | 12 PINS | |
| R _{θJA} | Junction-to-ambient thermal resistance | 50.4 | °C/W |
| R _{θJC(top)} | Junction-to-case (top) thermal resistance | 58 | °C/W |
| R _{θJB} | Junction-to-board thermal resistance | 19.9 | °C/W |
| ψ _{JT} | Junction-to-top characterization parameter | 0.9 | °C/W |
| ψ _{JB} | Junction-to-board characterization parameter | 20 | °C/W |
| R _{θJC(bot)} | Junction-to-case (bottom) thermal resistance | 6.9 | °C/W |

- (1) For more information about traditional and new thermal metrics, see the [Semiconductor and IC Package Thermal Metrics](#) application report.

6.5 Electrical Characteristics

 $T_A = 25^\circ\text{C}$, $V_M = 5\text{ V}$, $V_{CC} = 3\text{ V}$ (unless otherwise noted)

| PARAMETER | | TEST CONDITIONS | MIN | TYP | MAX | UNIT |
|----------------------------|-----------------------------------|--|----------------------|----------------------|-----------|------------------|
| POWER SUPPLY | | | | | | |
| I_{VM} | VM operating supply current | No PWM | | 40 | 100 | μA |
| | | 50 kHz PWM | | 0.8 | 1.5 | mA |
| I_{VMQ} | VM sleep mode supply current | nSLEEP = 0 V | | 30 | 95 | nA |
| I_{VCC} | VCC operating supply current | No PWM | | 300 | 500 | μA |
| | | 50 kHz PWM | | 0.7 | 1.5 | mA |
| I_{VCCQ} | VCC sleep mode supply current | nSLEEP = 0 V | | 5 | 25 | nA |
| V_{UVLO} | VCC undervoltage lockout voltage | V_{CC} rising | | | 1.8 | V |
| | | V_{CC} falling | | | 1.7 | V |
| LOGIC-LEVEL INPUTS | | | | | | |
| V_{IL} | Input low voltage | | $0.31 \times V_{CC}$ | $0.34 \times V_{CC}$ | | V |
| V_{IH} | Input high voltage | | $0.39 \times V_{CC}$ | $0.43 \times V_{CC}$ | | V |
| V_{HYS} | Input hysteresis | | $0.08 \times V_{CC}$ | | | V |
| I_{IL} | Input low current | $V_{IN} = 0$ | -5 | | 5 | μA |
| I_{IH} | Input high current | $V_{IN} = 3.3\text{ V}$ | | | 50 | μA |
| R_{PD} | Pulldown resistance | | | 100 | | $\text{k}\Omega$ |
| H-BRIDGE FETS | | | | | | |
| $R_{DS(ON)}$ | HS + LS FET on resistance | $I_O = 800\text{ mA}$, $T_J = 25^\circ\text{C}$ | | 280 | 330 | $\text{m}\Omega$ |
| I_{OFF} | OFF-state leakage current | | | | ± 200 | nA |
| PROTECTION CIRCUITS | | | | | | |
| I_{OCP} | Overcurrent protection trip level | | 1.9 | | 3.5 | A |
| t_{OCR} | Overcurrent protection retry time | | | 1 | | ms |
| t_{DEAD} | Output dead time | | | 100 | | ns |
| t_{TSD} | Thermal shutdown temperature | Die temperature | 150 | 160 | 180 | $^\circ\text{C}$ |

6.6 Timing Requirements ⁽¹⁾

 $T_A = 25^\circ\text{C}$, $V_M = 5\text{ V}$, $V_{CC} = 3\text{ V}$, $R_L = 20\ \Omega$

| | | | MIN | MAX | UNIT |
|---|-------|-----------------------------------|-----|-----|------|
| 1 | t_1 | Output enable time | | 120 | ns |
| 2 | t_2 | Output disable time | | 120 | ns |
| 3 | t_3 | Delay time, INx high to OUTx high | | 120 | ns |
| 4 | t_4 | Delay time, INx low to OUTx low | | 120 | ns |
| 5 | t_5 | Output rise time | 50 | 150 | ns |
| 6 | t_6 | Output fall time | 50 | 150 | ns |

(1) Not production tested – ensured by design

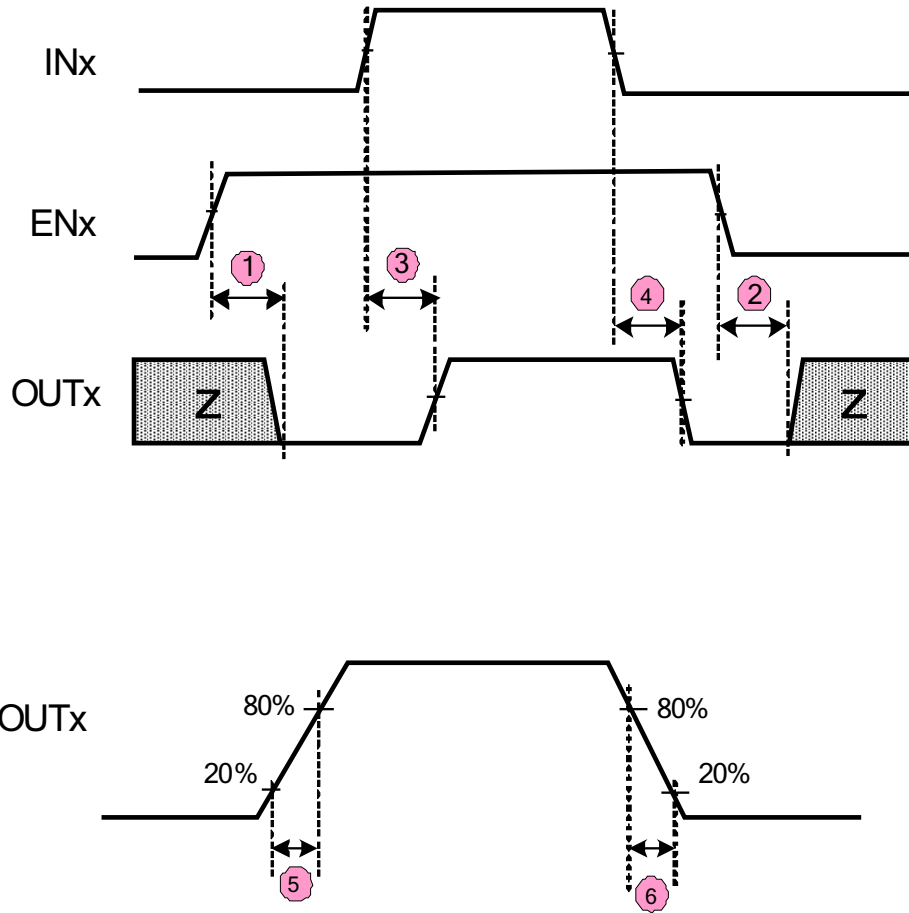
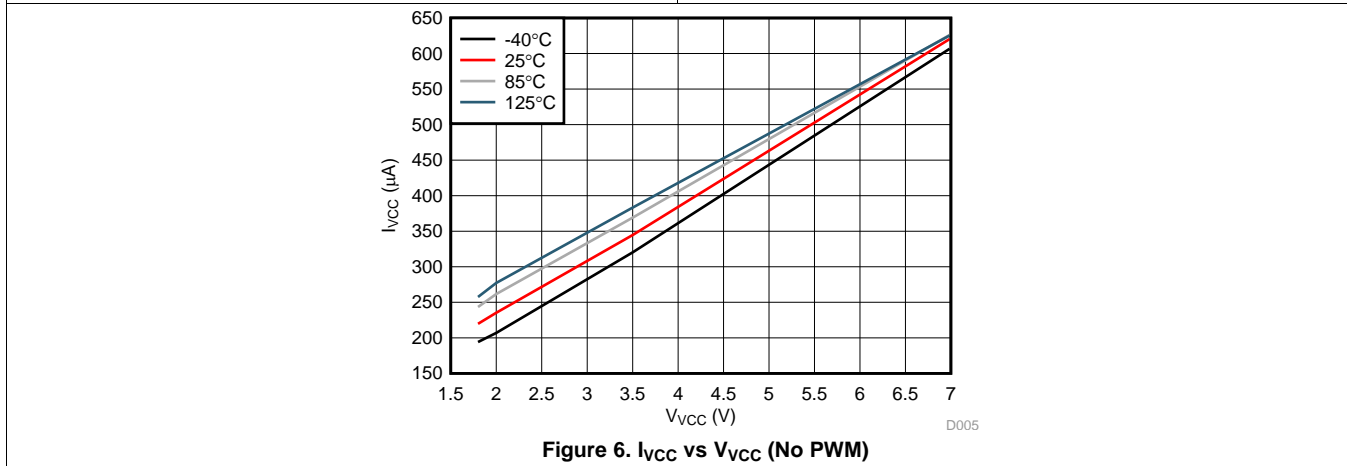
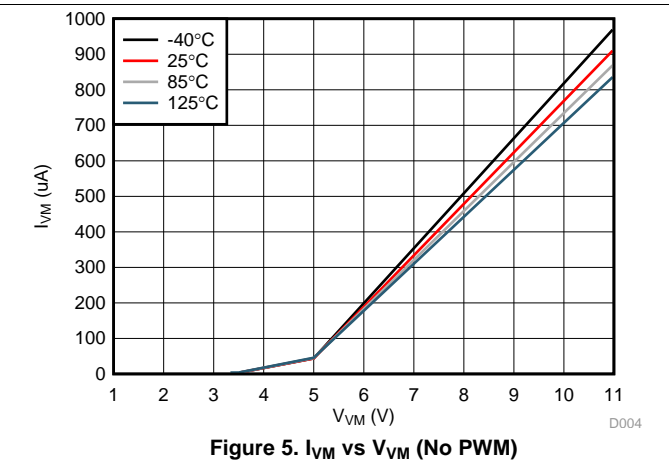
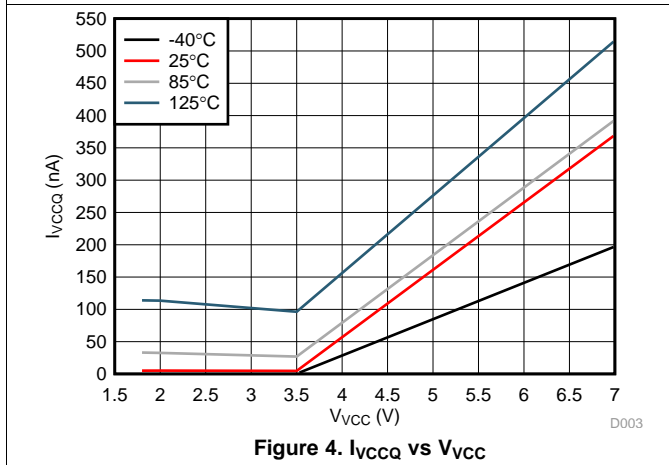
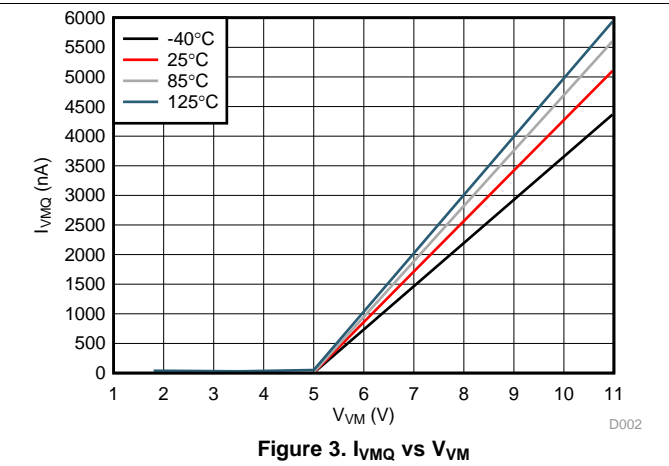
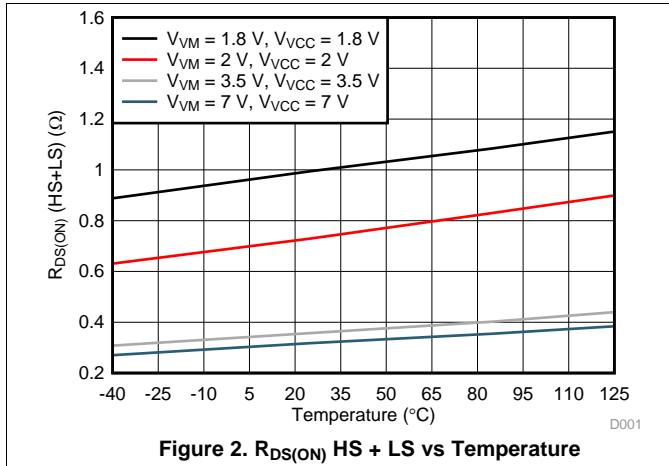

Figure 1. Timing Requirements

6.7 Typical Characteristics



7 Detailed Description

7.1 Overview

The DRV8839 is an integrated motor driver solution used for brushed motor control. The device integrates two independent $\frac{1}{2}$ H-bridge, and can drive one motor in both directions or two motors in one direction. The output driver block for each $\frac{1}{2}$ H-bridge consists of N-channel power MOSFETs. An internal charge pump generates the gate drive voltages. Protection features include overcurrent protection, short-circuit protection, undervoltage lockout, and overtemperature protection.

The DRV8839 allows separation of the motor voltage and logic voltage if desired. If VM and VCC are less than 7 V, the two voltages may be connected.

The control interface of the DRV8839 uses INx and ENx to control each $\frac{1}{2}$ H-bridge separately.

7.2 Functional Block Diagram

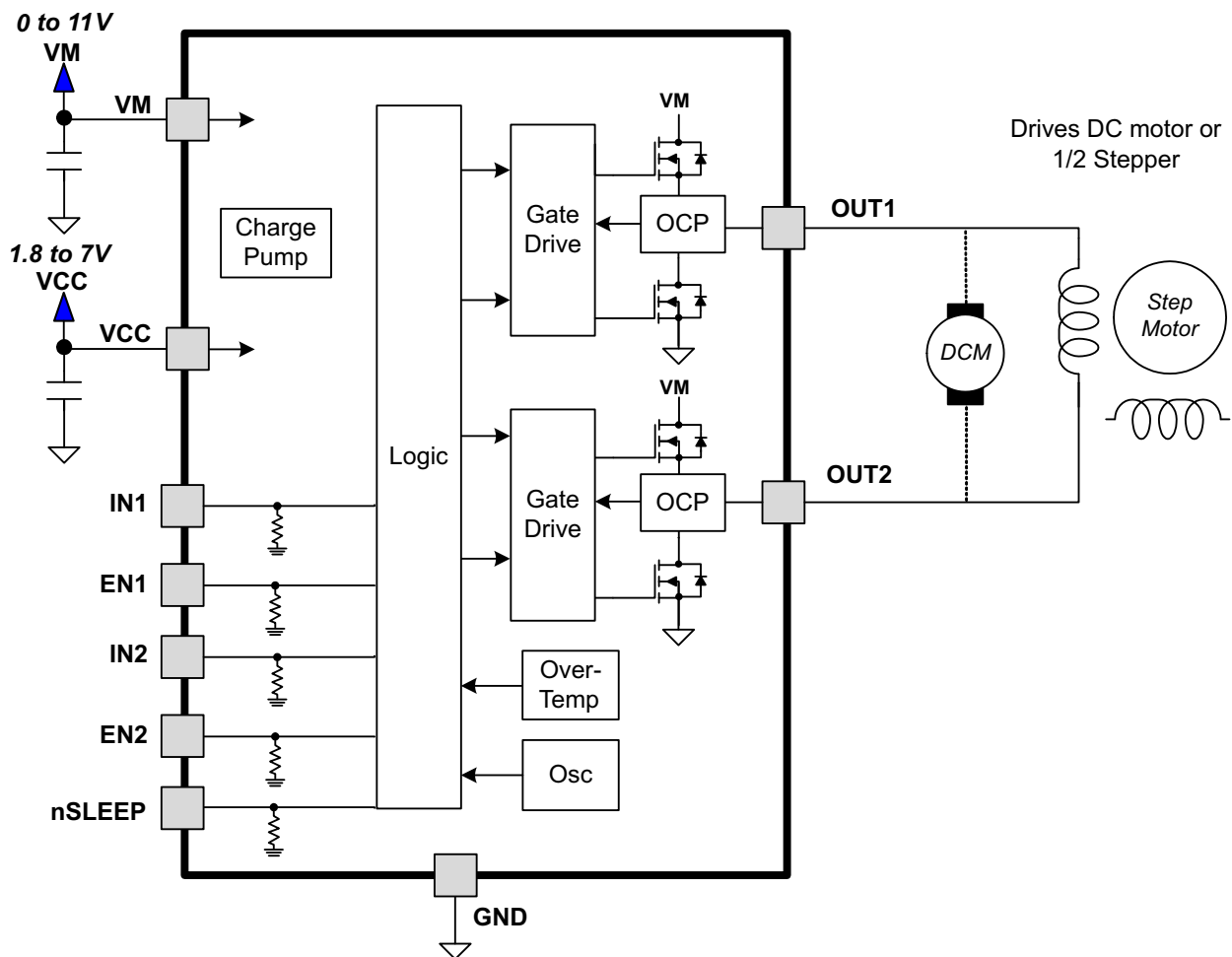

7.3 Feature Description

7.3.1 Protection Circuits

The DRV8839 is fully protected against undervoltage, overcurrent, and overtemperature events.

7.3.1.1 Overcurrent Protection (OCP)

An analog current limit circuit on each FET limits the current through the FET by removing the gate drive. If this analog current limit persists for longer than the OCP time, all FETs in the H-bridge disables. After approximately 1 ms, the bridge will be re-enabled automatically.

Overcurrent conditions on both high-side and low-side devices; a short to ground, supply, or across the motor winding result in an overcurrent shutdown.

7.3.1.2 Thermal Shutdown (TSD)

If the die temperature exceeds safe limits, all FETs in the H-bridge disables. Operation automatically resumes once the die temperature has fallen to a safe level.

7.3.1.3 Undervoltage Lockout (UVLO)

If at any time the voltage on the VCC pin falls below the undervoltage lockout threshold voltage, all circuitry in the device disables and internal logic resets. Operation resumes when VCC rises above the UVLO threshold.

Table 1. Device Protection

| FAULT | CONDITION | ERROR REPORT | H-BRIDGE | INTERNAL CIRCUITS | RECOVERY |
|-------------------------|-------------|--------------|----------|-------------------|------------------|
| VCC undervoltage (UVLO) | VCC < VUVLO | None | Disabled | Disabled | VCC > VUVLO |
| Overcurrent (OCP) | IOUT > IOCP | None | Disabled | Operating | tOCR |
| Thermal shutdown (TSD) | TJ > TTSD | None | Disabled | Operating | TJ < TTSD – THYS |

7.4 Device Functional Modes

The DRV8839 is active when the nSLEEP pin is set to a logic high. When in sleep mode, the ½ H-bridge FETs are disabled (High-Z).

Table 2. Device Operating Modes

| OPERATING MODE | CONDITION | H-BRIDGE | INTERNAL CIRCUITS |
|-------------------|-------------------------|-----------|-----------------------------|
| Operating | nSLEEP high | Operating | Operating |
| Sleep mode | nSLEEP low | Disabled | Disabled |
| Fault encountered | Any fault condition met | Disabled | See Table 1 |

7.4.1 Bridge Control

The DRV8839 is controlled using separate enable and input pins for each ½-H-bridge.

The following table shows the logic for the DRV8839:

Table 3. Bridge Control

| ENx | INx | OUTx |
|-----|-----|------|
| 0 | X | Z |
| 1 | 0 | L |
| 1 | 1 | H |

7.4.2 Sleep Mode

If the nSLEEP pin reaches a logic-low state, the DRV8839 enters a low-power sleep mode. In this state all unnecessary internal circuitry powers down.

7.4.3 Motor Connections

If a single DC motor connects to the DRV8839, it is connected between the OUT1 and OUT2 pins as shown in Figure 7:

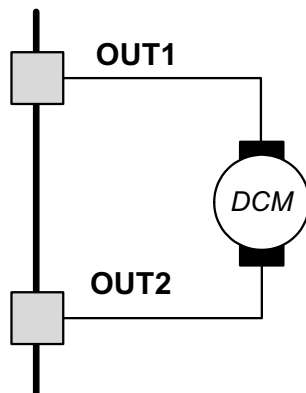

Figure 7. Single DC Motor Connection

Motor operation is controlled as show in Table 4.

Table 4. Single DC Motor Operation

| EN1 | EN2 | IN1 | IN2 | OUT1 | OUT2 | MOTOR OPERATION |
|-----|-----|-----|-----|--------------------|--------------------|-----------------|
| 0 | X | X | X | Z | See ⁽¹⁾ | Off (coast) |
| X | 0 | X | X | See ⁽²⁾ | Z | Off (coast) |
| 1 | 1 | 0 | 0 | L | L | Brake |
| 1 | 1 | 0 | 1 | L | H | Reverse |
| 1 | 1 | 1 | 0 | H | L | Forward |
| 1 | 1 | 1 | 1 | H | H | Brake |

(1) State depends on EN2 and IN2, but does not affect motor operation because OUT1 is tri-stated.

(2) State depends on EN1 and IN1, but does not affect motor operation because OUT2 is tri-stated.

Two DC motors can be connected to the DRV8839. In this mode, it is not possible to reverse the direction of the motors; they turn only in one direction. The connections are shown in [Figure 8](#):

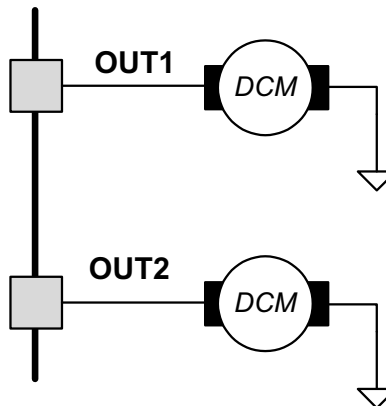

Figure 8. Dual DC Motor Connection

Motor operation is controlled shown in [Table 5](#).

Table 5. Dual DC Motor Operation

| ENx | INx | OUTx | MOTOR OPERATION |
|-----|-----|------|-----------------|
| 0 | X | Z | Off (coast) |
| 1 | 0 | L | Brake |
| 1 | 1 | H | Forward |

8 Application and Implementation

NOTE

Information in the following applications sections is not part of the TI component specification, and TI does not warrant its accuracy or completeness. TI's customers are responsible for determining suitability of components for their purposes. Customers should validate and test their design implementation to confirm system functionality.

8.1 Application Information

The DRV8839 is used in one control applications.

8.2 Typical Application

The following design is a common application of the DRV8839.

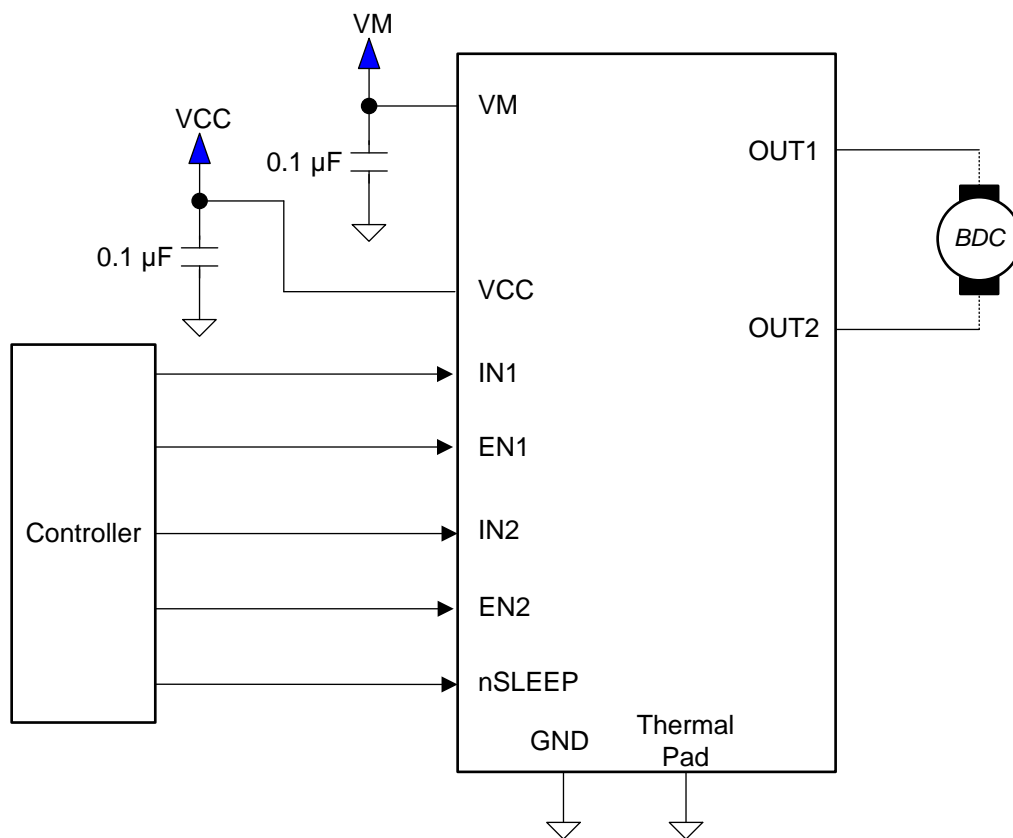

Copyright © 2016, Texas Instruments Incorporated

Figure 9. Typical Application Schematic

8.2.1 Design Requirements

The design requirements are shown in [Table 6](#).

Table 6. Design Requirements

| DESIGN PARAMETER | REFERENCE | EXAMPLE VALUE |
|-----------------------|-----------|---------------|
| Motor voltage | VM | 5 V |
| Motor RMS current | IRMS | 0.3 A |
| Motor startup current | ISTART | 0.6 A |

8.2.2 Detailed Design Procedure

The following design procedure can be used to configure the DRV8839 in a brushed motor application.

8.2.2.1 Motor Voltage

The appropriate motor voltage depends on the ratings of the motor selected and the desired RPM. A higher voltage spins a brushed DC motor faster with the same PWM duty cycle applied to the power FETs. A higher voltage also increases the rate of current change through the inductive motor windings.

8.2.2.2 Low-Power Operation

When entering sleep mode, TI recommends setting all inputs as a logic low to minimize system power.

8.2.2.3 Application Curves

The following scope captures show a typical motor startup and running. Channel 1 is VM, Channel 2 is IN1, Channel 3 is IN2, and Channel 4 is motor current. the motor used is a NMB Technologies, PPN7PA12C1.

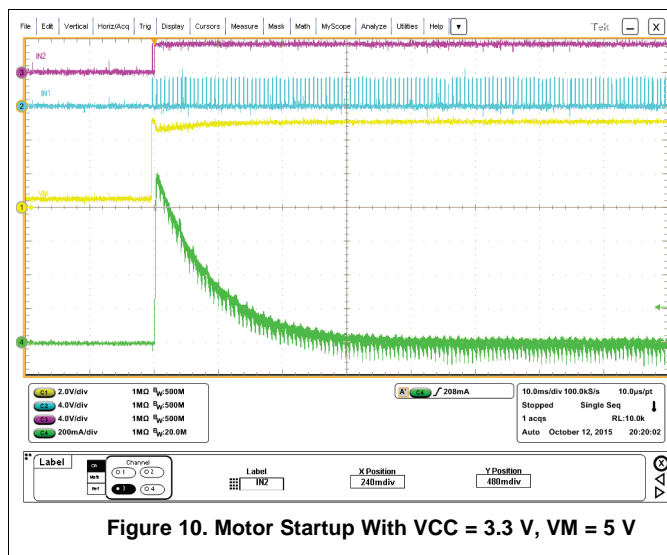

Figure 10. Motor Startup With VCC = 3.3 V, VM = 5 V

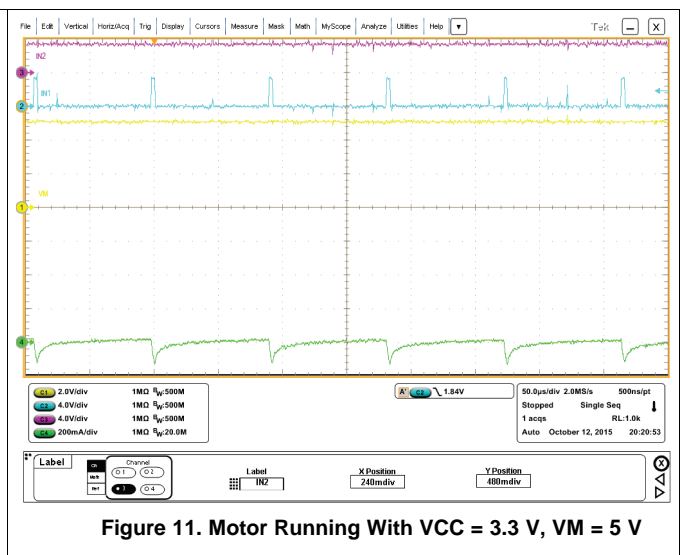

Figure 11. Motor Running With VCC = 3.3 V, VM = 5 V

9 Power Supply Recommendations

The input pins can drive within their recommended operating conditions with or without the VCC and VM power supplies present. No leakage current path exists to the supply. There is a weak pull-down resistor (approximately 100 k Ω) to ground on each input pin.

VCC and VM can be applied and removed in any order. When VCC is removed, the device enters a low-power state and draws very little current from VM. If the supply voltage is between 1.8 V and 7 V, VCC and VM can connect together.

The VM voltage supply does not have any undervoltage lockout protection (UVLO), so as long as VCC > 1.8 V, the internal device logic remains active. This means that the VM pin voltage may drop to 0 V, however, the load may not be sufficiently driven at low VM voltages.

9.1 Bulk Capacitance

Having appropriate local bulk capacitance is an important factor in motor drive system design. It is generally beneficial to have more bulk capacitance, while the disadvantages are increased cost and physical size.

The required amount of local capacitance depends on a variety of factors, including:

- The highest current required by the motor system
- The power supply's capacitance and ability to source current
- The amount of parasitic inductance between the power supply and motor system
- The acceptable voltage ripple
- The type of motor used (brushed DC, brushless DC, stepper)
- The motor braking method

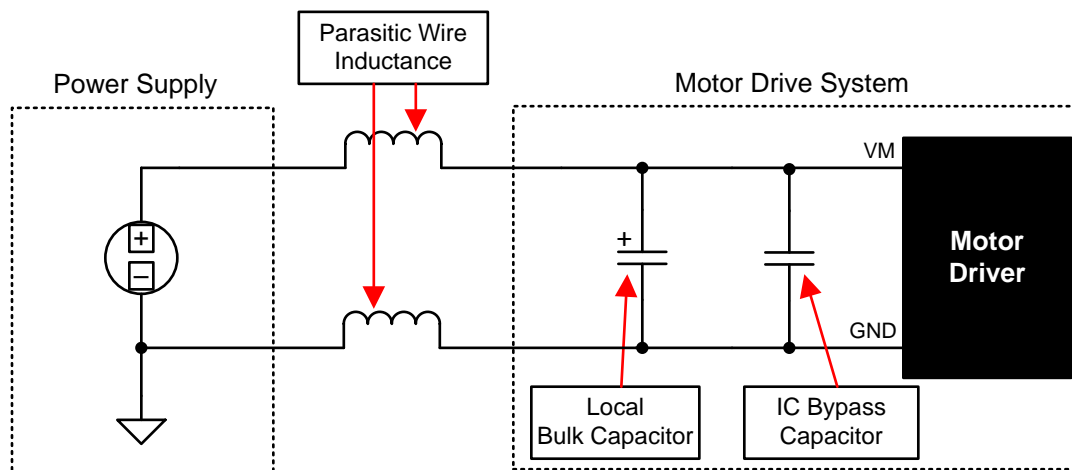

Figure 12. Bulk Capacitance

10 Layout

10.1 Layout Guidelines

The VCC pin should be bypassed to GND using low-ESR ceramic bypass capacitors with a recommended value of 0.1- μ F rated for VCC. This capacitor should be placed as close to the VCC pin as possible with a thick trace.

The VM pin should be bypassed to GND using low-ESR ceramic bypass capacitors with a recommended value of 0.1 μ F rated for VM. This capacitor should be placed as close to the VM pin as possible with a thick trace. The VM pin must bypass to ground using an appropriate bulk capacitor. This component can be an electrolytic and should be located close to the DRV8839 device.

10.2 Layout Example

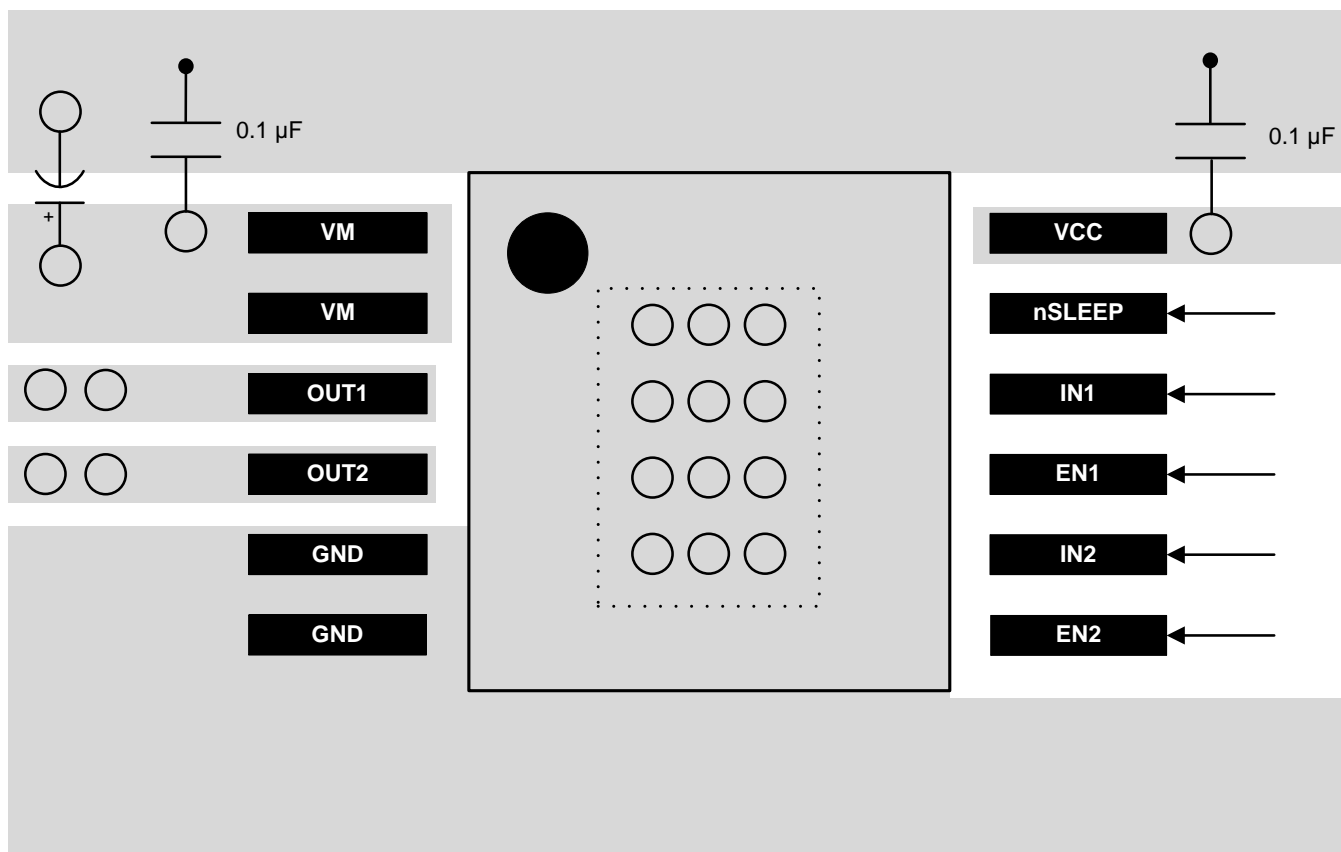

Figure 13. Layout Recommendation

10.3 Thermal Considerations

The DRV8839 has thermal shutdown (TSD) as described above. If the die temperature exceeds approximately 150°C, the device disables until the temperature drops to a safe level.

Any tendency of the device to enter thermal shutdown is an indication of either excessive power dissipation, insufficient heatsinking, or too high an ambient temperature.

10.3.1 Power Dissipation

The power dissipation of the DRV8839 is a function of RMS motor current and the each output's FET resistance ($R_{DS(ON)}$) as seen in [Equation 1](#):

$$\text{Power} \approx I_{RMS}^2 \times (\text{High-Side } R_{DS(ON)} + \text{Low-Side } R_{DS(ON)}) \quad (1)$$

Thermal Considerations (continued)

For this example, $V_{VM} = 1.8\text{ V}$, $V_{VCC} = 1.8\text{ V}$, the ambient temperature is 35°C , and the junction temperature reaches 65°C . At 65°C , the sum of $R_{DS(ON)}$ is about $1\ \Omega$. With an example motor current of 0.8 A , the dissipated power in the form of heat will be $0.8\text{ A}^2 \times 1\ \Omega = 0.64\text{ W}$.

The temperature that the DRV8839 reaches will depend on the thermal resistance to the air and PCB. It is important to solder the device thermal pad to the PCB ground plane, with vias to the top and bottom board layers, in order to dissipate heat into the PCB and reduce the device temperature. In the example used here, the DRV8839 had an effective thermal resistance $R_{\theta JA}$ of 47°C/W , and as shown in [Equation 2](#):

$$T_J = T_A + (P_D \times R_{\theta JA}) = 35^\circ\text{C} + (0.64\text{ W} \times 47^\circ\text{C/W}) = 65^\circ\text{C} \quad (2)$$

11 Device and Documentation Support

11.1 Documentation Support

11.1.1 Related Documentation

For related documentation see the following:

- [AN-1187 Leadless Leadframe Package \(LLP\)](#) (SNOA401)
- [DRV8839 Evaluation Module](#) (SLVU879)
- [QFN/SON PCB Attachment](#) (SLUA271)

11.2 Receiving Notification of Documentation Updates

To receive notification of documentation updates, navigate to the device product folder on ti.com. In the upper right corner, click on *Alert me* to register and receive a weekly digest of any product information that has changed. For change details, review the revision history included in any revised document.

11.3 Community Resources

The following links connect to TI community resources. Linked contents are provided "AS IS" by the respective contributors. They do not constitute TI specifications and do not necessarily reflect TI's views; see TI's [Terms of Use](#).

TI E2E™ Online Community *TI's Engineer-to-Engineer (E2E) Community*. Created to foster collaboration among engineers. At e2e.ti.com, you can ask questions, share knowledge, explore ideas and help solve problems with fellow engineers.

Design Support *TI's Design Support* Quickly find helpful E2E forums along with design support tools and contact information for technical support.

11.4 Trademarks

E2E is a trademark of Texas Instruments.
All other trademarks are the property of their respective owners.

11.5 Electrostatic Discharge Caution



These devices have limited built-in ESD protection. The leads should be shorted together or the device placed in conductive foam during storage or handling to prevent electrostatic damage to the MOS gates.

11.6 Glossary

[SLYZ022](#) — *TI Glossary*.

This glossary lists and explains terms, acronyms, and definitions.

12 Mechanical, Packaging, and Orderable Information

The following pages include mechanical, packaging, and orderable information. This information is the most current data available for the designated devices. This data is subject to change without notice and revision of this document. For browser-based versions of this data sheet, refer to the left-hand navigation.

PACKAGING INFORMATION

| Orderable part number | Status (1) | Material type (2) | Package Pins | Package qty Carrier | RoHS (3) | Lead finish/ Ball material (4) | MSL rating/ Peak reflow (5) | Op temp (°C) | Part marking (6) |
|-----------------------------|---------------|----------------------|-----------------|-----------------------|-------------|--------------------------------------|-----------------------------------|--------------|---------------------|
| DRV8839DSSR | Active | Production | WSON (DSS) 12 | 3000 LARGE T&R | Yes | NIPDAU | Level-1-260C-UNLIM | -40 to 85 | 8839 |
| DRV8839DSSR.B | Active | Production | WSON (DSS) 12 | 3000 LARGE T&R | Yes | NIPDAU | Level-1-260C-UNLIM | -40 to 85 | 8839 |
| DRV8839DSSRG4 | Active | Production | WSON (DSS) 12 | 3000 LARGE T&R | Yes | NIPDAU | Level-1-260C-UNLIM | -40 to 85 | 8839 |
| DRV8839DSSRG4.B | Active | Production | WSON (DSS) 12 | 3000 LARGE T&R | Yes | NIPDAU | Level-1-260C-UNLIM | -40 to 85 | 8839 |

(1) **Status:** For more details on status, see our [product life cycle](#).

(2) **Material type:** When designated, preproduction parts are prototypes/experimental devices, and are not yet approved or released for full production. Testing and final process, including without limitation quality assurance, reliability performance testing, and/or process qualification, may not yet be complete, and this item is subject to further changes or possible discontinuation. If available for ordering, purchases will be subject to an additional waiver at checkout, and are intended for early internal evaluation purposes only. These items are sold without warranties of any kind.

(3) **RoHS values:** Yes, No, RoHS Exempt. See the [TI RoHS Statement](#) for additional information and value definition.

(4) **Lead finish/Ball material:** Parts may have multiple material finish options. Finish options are separated by a vertical ruled line. Lead finish/Ball material values may wrap to two lines if the finish value exceeds the maximum column width.

(5) **MSL rating/Peak reflow:** The moisture sensitivity level ratings and peak solder (reflow) temperatures. In the event that a part has multiple moisture sensitivity ratings, only the lowest level per JEDEC standards is shown. Refer to the shipping label for the actual reflow temperature that will be used to mount the part to the printed circuit board.

(6) **Part marking:** There may be an additional marking, which relates to the logo, the lot trace code information, or the environmental category of the part.

Multiple part markings will be inside parentheses. Only one part marking contained in parentheses and separated by a "~" will appear on a part. If a line is indented then it is a continuation of the previous line and the two combined represent the entire part marking for that device.

Important Information and Disclaimer: The information provided on this page represents TI's knowledge and belief as of the date that it is provided. TI bases its knowledge and belief on information provided by third parties, and makes no representation or warranty as to the accuracy of such information. Efforts are underway to better integrate information from third parties. TI has taken and continues to take reasonable steps to provide representative and accurate information but may not have conducted destructive testing or chemical analysis on incoming materials and chemicals. TI and TI suppliers consider certain information to be proprietary, and thus CAS numbers and other limited information may not be available for release.

In no event shall TI's liability arising out of such information exceed the total purchase price of the TI part(s) at issue in this document sold by TI to Customer on an annual basis.

TAPE AND REEL INFORMATION

QUADRANT ASSIGNMENTS FOR PIN 1 ORIENTATION IN TAPE



*All dimensions are nominal

| Device | Package Type | Package Drawing | Pins | SPQ | Reel Diameter (mm) | Reel Width W1 (mm) | A0 (mm) | B0 (mm) | K0 (mm) | P1 (mm) | W (mm) | Pin1 Quadrant |
|---------------|--------------|-----------------|------|------|--------------------|--------------------|---------|---------|---------|---------|--------|---------------|
| DRV8839DSSR | WSON | DSS | 12 | 3000 | 180.0 | 8.4 | 2.25 | 3.25 | 1.05 | 4.0 | 8.0 | Q1 |
| DRV8839DSSRG4 | WSON | DSS | 12 | 3000 | 180.0 | 8.4 | 2.25 | 3.25 | 1.05 | 4.0 | 8.0 | Q1 |

TAPE AND REEL BOX DIMENSIONS

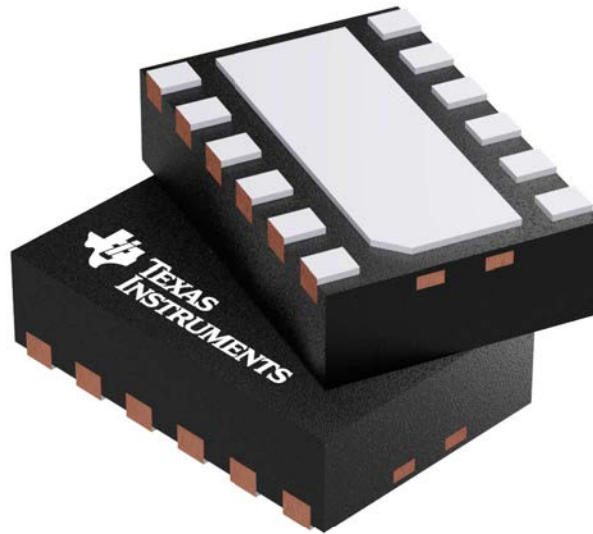

*All dimensions are nominal

| Device | Package Type | Package Drawing | Pins | SPQ | Length (mm) | Width (mm) | Height (mm) |
|---------------|--------------|-----------------|------|------|-------------|------------|-------------|
| DRV8839DSSR | WSON | DSS | 12 | 3000 | 182.0 | 182.0 | 20.0 |
| DRV8839DSSRG4 | WSON | DSS | 12 | 3000 | 182.0 | 182.0 | 20.0 |

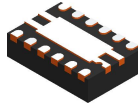

Images above are just a representation of the package family, actual package may vary.
Refer to the product data sheet for package details.

DSS0012A



PACKAGE OUTLINE

WSON - 0.8 mm max height

PLASTIC SMALL OUTLINE - NO LEAD

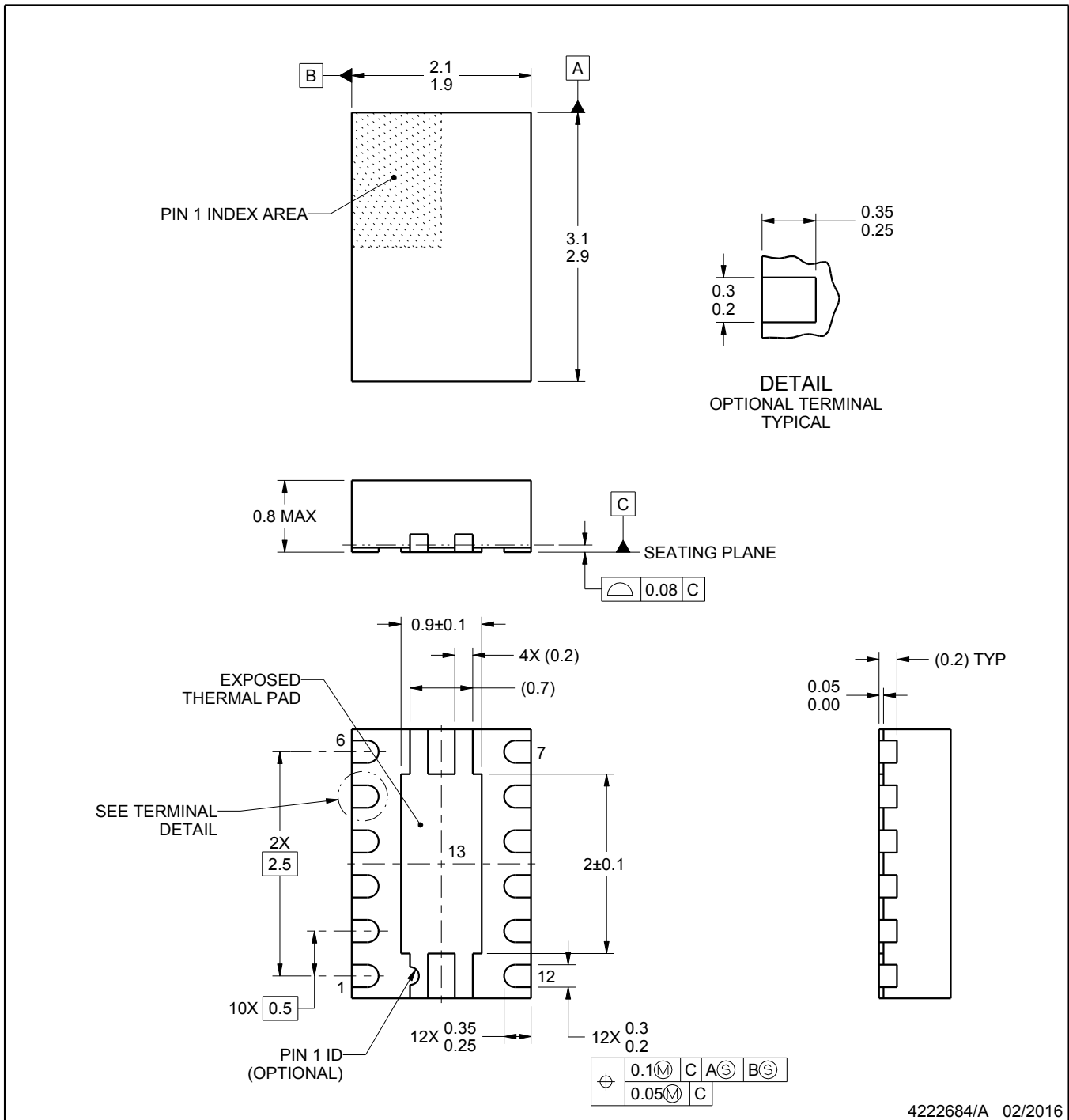

NOTES:

1. All linear dimensions are in millimeters. Any dimensions in parenthesis are for reference only. Dimensioning and tolerancing per ASME Y14.5M.
2. This drawing is subject to change without notice.
3. The package thermal pad must be soldered to the printed circuit board for thermal and mechanical performance.

EXAMPLE BOARD LAYOUT

DSS0012A

WSON - 0.8 mm max height

PLASTIC SMALL OUTLINE - NO LEAD

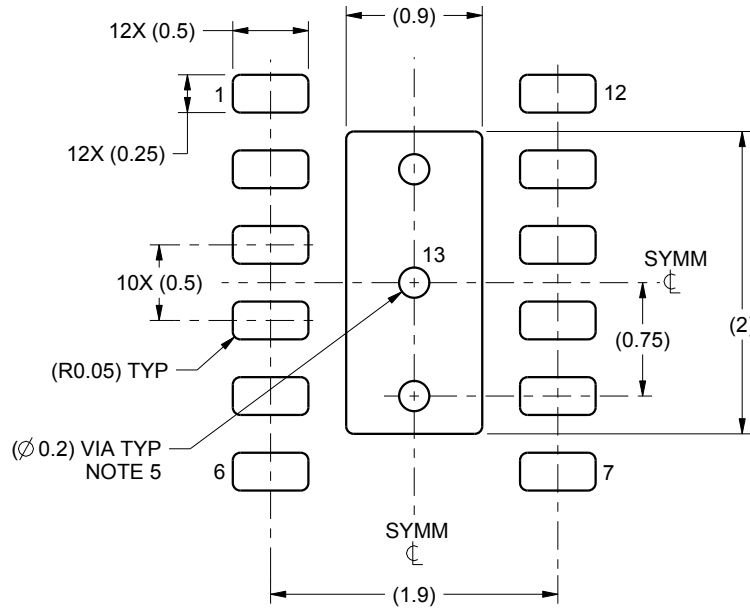

LAND PATTERN EXAMPLE
SCALE:20X

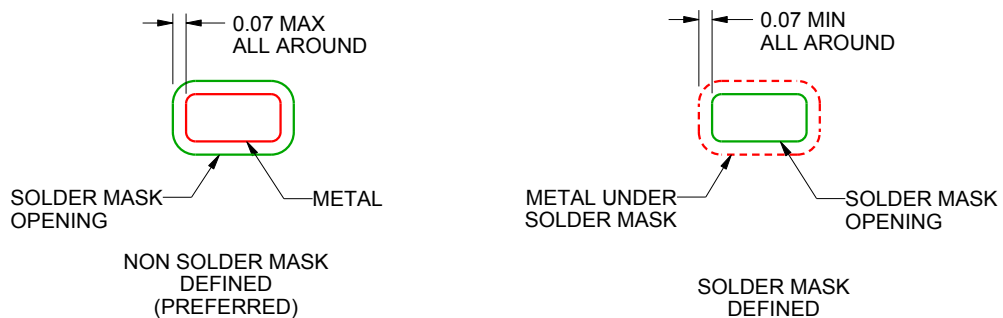

SOLDER MASK DETAILS

4222684/A 02/2016

NOTES: (continued)

4. This package is designed to be soldered to a thermal pad on the board. For more information, see Texas Instruments literature number SLUA271 (www.ti.com/lit/sl原因271).
5. Vias are optional depending on application, refer to device data sheet. If some or all are implemented, recommended via locations are shown. It is recommended that vias located under solder paste be filled, plugged or tented.

EXAMPLE STENCIL DESIGN

DSS0012A

WSON - 0.8 mm max height

PLASTIC SMALL OUTLINE - NO LEAD

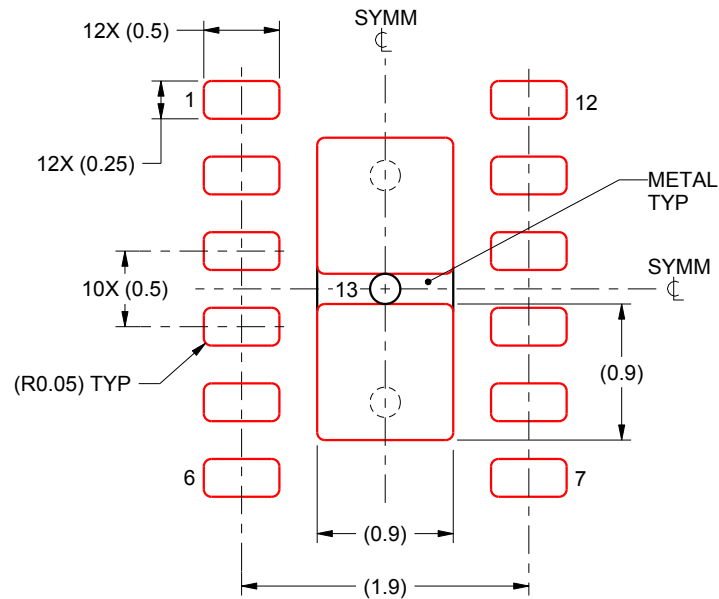

SOLDER PASTE EXAMPLE
BASED ON 0.125 mm THICK STENCIL

EXPOSED PAD 13:
90% PRINTED SOLDER COVERAGE BY AREA UNDER PACKAGE
SCALE:20X

4222684/A 02/2016

NOTES: (continued)

6. Laser cutting apertures with trapezoidal walls and rounded corners may offer better paste release. IPC-7525 may have alternate design recommendations.

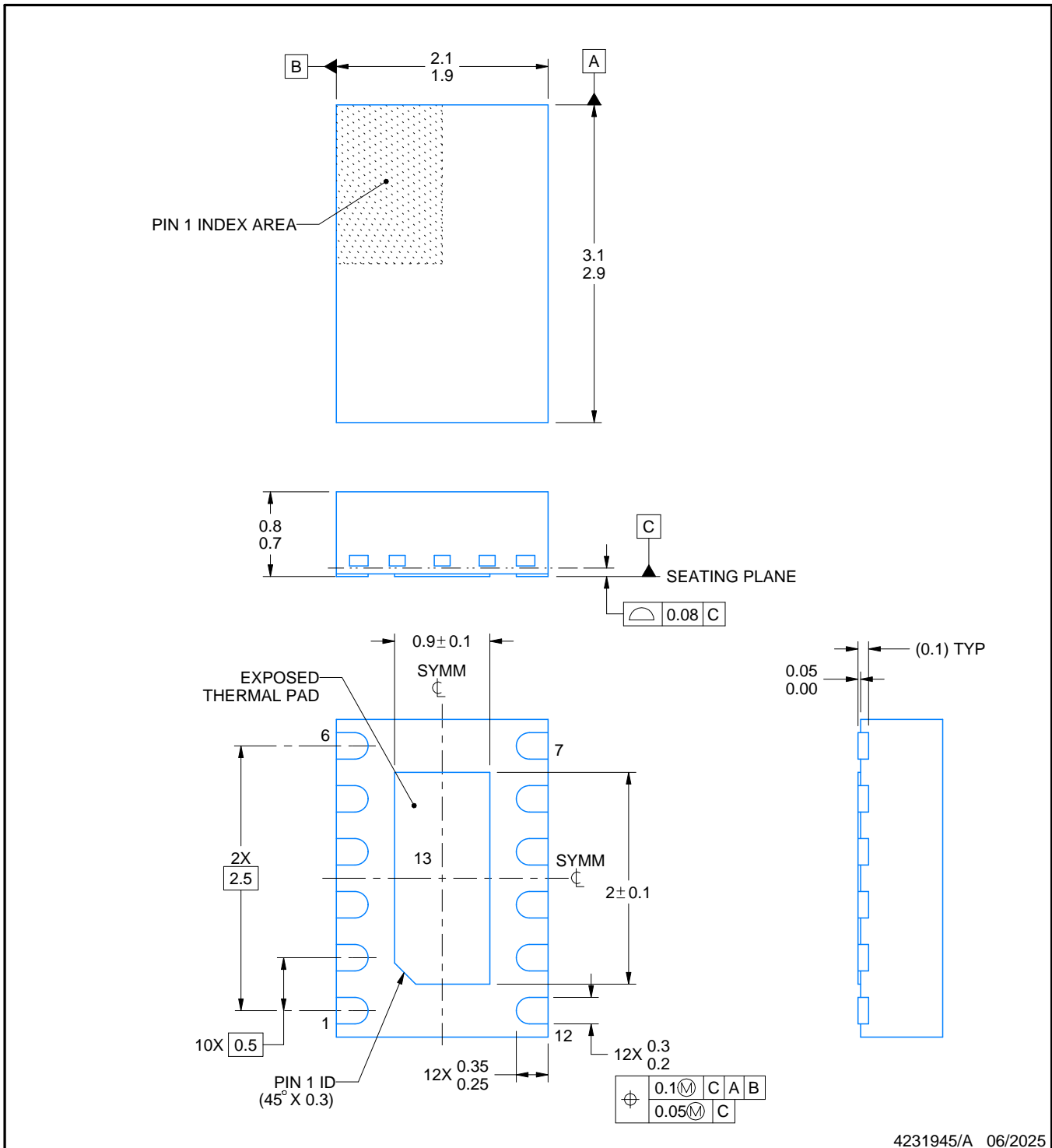
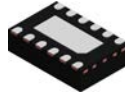

4231945/A 06/2025

NOTES:

1. All linear dimensions are in millimeters. Any dimensions in parenthesis are for reference only. Dimensioning and tolerancing per ASME Y14.5M.
2. This drawing is subject to change without notice.
3. The package thermal pad must be soldered to the printed circuit board for optimal thermal and mechanical performance.

EXAMPLE BOARD LAYOUT

DSS0012D

WSON - 0.8 mm max height

PLASTIC SMALL OUTLINE - NO LEAD

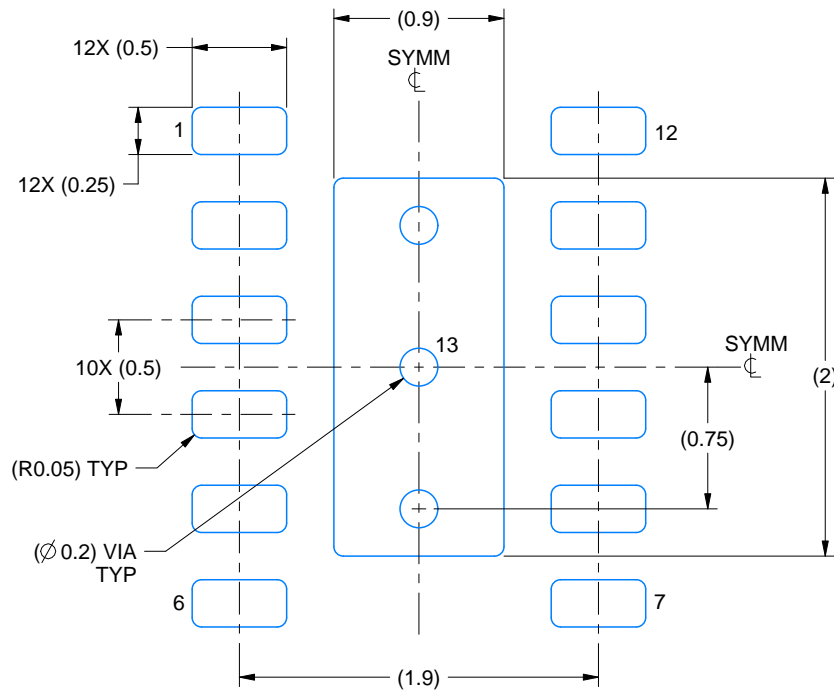

LAND PATTERN EXAMPLE
EXPOSED METAL SHOWN
SCALE:25X

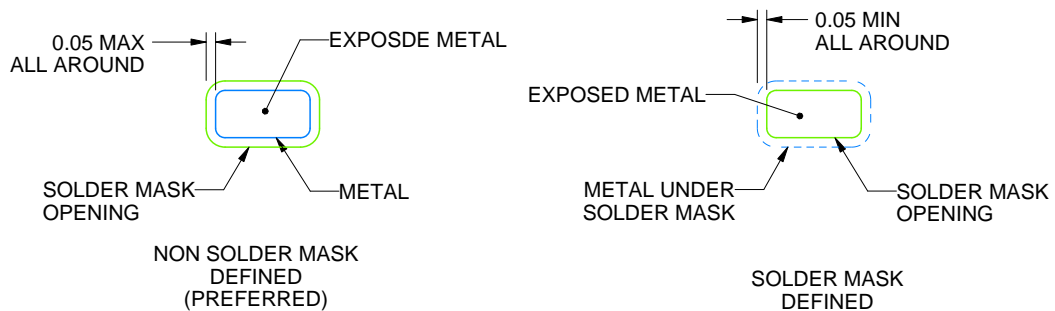

SOLDER MASK DETAILS

4231945/A 06/2025

NOTES: (continued)

4. This package is designed to be soldered to a thermal pad on the board. For more information, see Texas Instruments literature number SLUA271 (www.ti.com/lit/sluea271).
5. Vias are optional depending on application, refer to device data sheet. If any vias are implemented, refer to their locations shown on this view. It is recommended that vias under paste be filled, plugged or tented.

EXAMPLE STENCIL DESIGN

DSS0012D

WSON - 0.8 mm max height

PLASTIC SMALL OUTLINE - NO LEAD

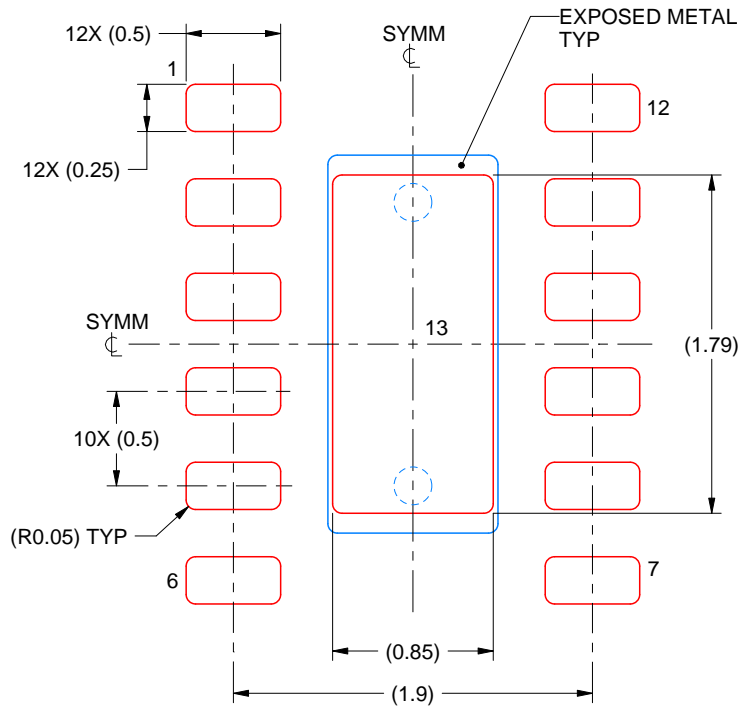

SOLDER PASTE EXAMPLE
BASED ON 0.125 mm THICK STENCIL

EXPOSED PAD 13:
85% PRINTED SOLDER COVERAGE BY AREA UNDER PACKAGE
SCALE:25X

4231945/A 06/2025

NOTES: (continued)

6. Laser cutting apertures with trapezoidal walls and rounded corners may offer better paste release. IPC-7525 may have alternate design recommendations.

IMPORTANT NOTICE AND DISCLAIMER

TI PROVIDES TECHNICAL AND RELIABILITY DATA (INCLUDING DATASHEETS), DESIGN RESOURCES (INCLUDING REFERENCE DESIGNS), APPLICATION OR OTHER DESIGN ADVICE, WEB TOOLS, SAFETY INFORMATION, AND OTHER RESOURCES "AS IS" AND WITH ALL FAULTS, AND DISCLAIMS ALL WARRANTIES, EXPRESS AND IMPLIED, INCLUDING WITHOUT LIMITATION ANY IMPLIED WARRANTIES OF MERCHANTABILITY, FITNESS FOR A PARTICULAR PURPOSE OR NON-INFRINGEMENT OF THIRD PARTY INTELLECTUAL PROPERTY RIGHTS.

These resources are intended for skilled developers designing with TI products. You are solely responsible for (1) selecting the appropriate TI products for your application, (2) designing, validating and testing your application, and (3) ensuring your application meets applicable standards, and any other safety, security, regulatory or other requirements.

These resources are subject to change without notice. TI grants you permission to use these resources only for development of an application that uses the TI products described in the resource. Other reproduction and display of these resources is prohibited. No license is granted to any other TI intellectual property right or to any third party intellectual property right. TI disclaims responsibility for, and you fully indemnify TI and its representatives against any claims, damages, costs, losses, and liabilities arising out of your use of these resources.

TI's products are provided subject to [TI's Terms of Sale](#), [TI's General Quality Guidelines](#), or other applicable terms available either on [ti.com](#) or provided in conjunction with such TI products. TI's provision of these resources does not expand or otherwise alter TI's applicable warranties or warranty disclaimers for TI products. Unless TI explicitly designates a product as custom or customer-specified, TI products are standard, catalog, general purpose devices.

TI objects to and rejects any additional or different terms you may propose.

Copyright © 2026, Texas Instruments Incorporated

Last updated 10/2025