

DS160PT801 PCIe® 4.0, 16 Gbps, 8-Lane (16-Channel) Retimer

1 Features

- 8-lane (16-channel) protocol-aware PCI-express retimer supporting 16.0, 8.0, 5.0, and 2.5 GT/s interfaces
- Inter-chip communication (ICC) enable dual chip link width scaling to form 16-lane Gen-4 retimer
- Supports common clock, separate reference clock with no spread spectrum clocking (SSC), and separate reference clock with SSC
- Supports 2x4 bifurcation
- Adaptive receive CTLE and DFE supporting maximum PCIe Gen-4 channel loss
- Supports equalization training
- Low-latency architecture
- On-chip eye opening monitor (EOM) and PCIe receive margining capability
- Small 8.50-mm × 13.40-mm BGA package
- Flow-through pinout enables signal breakout in two signal layers
- Compatible with standard 1.00-mm BGA PCB manufacturing
- Dual power supply: 1.17 V and 1.8 V
- I2C configuration (up to 1 MHz) through the external EEPROM or I2C controller
- Industrial temperature range: -40°C to 85°C

2 Applications

- [Rack server](#)
- [Microserver and tower server](#)
- [High performance computing](#)
- [Hardware accelerator](#)

3 Description

The DS160PT801 is a high-performance eight-lane (16-channel) PCI-Express protocol-aware retimer supporting all standard PCIe data rates up to 16 GT/s. It is used to extend the reach and robustness of high-speed PCIe serial links, from chip-to-chip motherboard links to more complex multi-connector system topologies.

The DS160PT801 supports both common-clock and independent reference clock architectures, with and without spread-spectrum clocking. This allows for maximum flexibility in defining the system clock architecture.

The eight lanes in the DS160PT801 can be bifurcated into two x4 links to support different system topologies.

A compact yet easy-to-manufacture BGA package provides excellent thermal performance while enabling optimal placement in space-constrained applications like 1RU riser cards. This feature reduces overall solution size, PCB routing complexity, and BOM cost.

Diagnostic capabilities include in-band receiver margining, out-of-band non-destructive horizontal or vertical eye margin monitor, receiver loopback, encoding error detection, and on die temperature sensor. These features help gauge link margin and can be used to monitor system health over time.

The DS160PT801 is configurable through SMBus interface. The Initial configuration can be automatically loaded from external EEPROM.

Device Information⁽¹⁾

PART NUMBER	PACKAGE	BODY SIZE (NOM)
DS160PT801	FCCSP (332)	8.50 mm × 13.40 mm

(1) For all available packages, see the orderable addendum at the end of the data sheet.

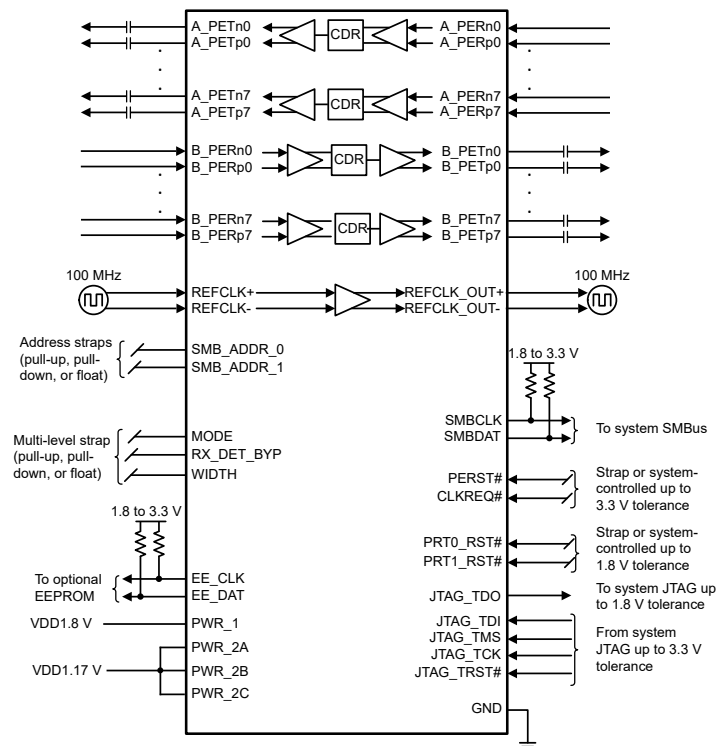

Simplified Schematic

Table of Contents

1 Features	1	6.2 Documentation Support.....	4
2 Applications	1	6.3 Receiving Notification of Documentation Updates.....	4
3 Description	1	6.4 Support Resources.....	4
4 Revision History	2	6.5 Trademarks.....	4
5 Device Comparison	3	6.6 Electrostatic Discharge Caution.....	4
6 Device and Documentation Support	4	6.7 Glossary.....	4
6.1 Device Support.....	4	7 Mechanical, Packaging, and Orderable Information	4

4 Revision History

NOTE: Page numbers for previous revisions may differ from page numbers in the current version.

Changes from Revision * (December 2020) to Revision A (June 2022)	Page
• Changed the status of the data sheet from: <i>Advanced Information</i> to: <i>Production Data</i>	1

5 Device Comparison

PART NUMBER	LINK WIDTH	PCIe GEN	DEVICE TYPE
DS160PT801	x8	4, 3, 2, 1	Retimer

6 Device and Documentation Support

6.1 Device Support

6.1.1 Development Support

- **IBIS-AMI model.** Simulate the DS160PT801's high-speed receiver and transmitter in tools which support IBIS-AMI simulations. Contact your local Texas Instruments sales representative for the latest status of available models.

6.1.2 12.1.2 Device Nomenclature

- **x2** – Two-lane PCI-Express Link, also referred to as by-2.
- **x4** – Four-lane PCI-Express Link, also referred to as by-4.
- **x8** – Eight-lane PCI-Express Link, also referred to as by-8.
- **x16** – Sixteen-lane PCI-Express Link, also referred to as by-16.
- **Bifurcation** – Dividing a by-M PCI-Express Link (for example, x8) into two or more separate by-N Links (for example, two x4), where $N < M$.
- **Stacking** – Combining multiple by-N devices (for example, two x8) to form a by-M interface (for example, x16), where $M > N$.

6.2 Documentation Support

6.2.1 Related Documentation

For related documentation, see the following:

- Texas Instrument, [DS160PT801 Evaluation Board reference design](#)

6.3 Receiving Notification of Documentation Updates

To receive notification of documentation updates, navigate to the device product folder on [ti.com](#). Click on *Subscribe to updates* to register and receive a weekly digest of any product information that has changed. For change details, review the revision history included in any revised document.

6.4 Support Resources

[TI E2E™ support forums](#) are an engineer's go-to source for fast, verified answers and design help — straight from the experts. Search existing answers or ask your own question to get the quick design help you need.

Linked content is provided "AS IS" by the respective contributors. They do not constitute TI specifications and do not necessarily reflect TI's views; see TI's [Terms of Use](#).

6.5 Trademarks

TI E2E™ is a trademark of Texas Instruments.

PCIe® is a registered trademark of PCI-SIG.

All trademarks are the property of their respective owners.

6.6 Electrostatic Discharge Caution



This integrated circuit can be damaged by ESD. Texas Instruments recommends that all integrated circuits be handled with appropriate precautions. Failure to observe proper handling and installation procedures can cause damage.

ESD damage can range from subtle performance degradation to complete device failure. Precision integrated circuits may be more susceptible to damage because very small parametric changes could cause the device not to meet its published specifications.

6.7 Glossary

[TI Glossary](#) This glossary lists and explains terms, acronyms, and definitions.

7 Mechanical, Packaging, and Orderable Information

The following pages include mechanical, packaging, and orderable information. This information is the most current data available for the designated devices. This data is subject to change without notice and revision of this document. For browser-based versions of this data sheet, refer to the left-hand navigation.

PACKAGING INFORMATION

Orderable part number	Status (1)	Material type (2)	Package Pins	Package qty Carrier	RoHS (3)	Lead finish/ Ball material (4)	MSL rating/ Peak reflow (5)	Op temp (°C)	Part marking (6)
DS160PT801ACBR	Active	Production	FCCSP (ACB) 332	2000 LARGE T&R	Yes	SNAGCU	Level-3-260C-168 HR	-40 to 85	D160PT801
DS160PT801ACBR.A	Active	Production	FCCSP (ACB) 332	2000 LARGE T&R	Yes	SNAGCU	Level-3-260C-168 HR	-40 to 85	D160PT801
DS160PT801ACBT	Active	Production	FCCSP (ACB) 332	250 SMALL T&R	Yes	SNAGCU	Level-3-260C-168 HR	-40 to 85	D160PT801
DS160PT801ACBT.A	Active	Production	FCCSP (ACB) 332	250 SMALL T&R	Yes	SNAGCU	Level-3-260C-168 HR	-40 to 85	D160PT801

⁽¹⁾ **Status:** For more details on status, see our [product life cycle](#).

⁽²⁾ **Material type:** When designated, preproduction parts are prototypes/experimental devices, and are not yet approved or released for full production. Testing and final process, including without limitation quality assurance, reliability performance testing, and/or process qualification, may not yet be complete, and this item is subject to further changes or possible discontinuation. If available for ordering, purchases will be subject to an additional waiver at checkout, and are intended for early internal evaluation purposes only. These items are sold without warranties of any kind.

⁽³⁾ **RoHS values:** Yes, No, RoHS Exempt. See the [TI RoHS Statement](#) for additional information and value definition.

⁽⁴⁾ **Lead finish/Ball material:** Parts may have multiple material finish options. Finish options are separated by a vertical ruled line. Lead finish/Ball material values may wrap to two lines if the finish value exceeds the maximum column width.

⁽⁵⁾ **MSL rating/Peak reflow:** The moisture sensitivity level ratings and peak solder (reflow) temperatures. In the event that a part has multiple moisture sensitivity ratings, only the lowest level per JEDEC standards is shown. Refer to the shipping label for the actual reflow temperature that will be used to mount the part to the printed circuit board.

⁽⁶⁾ **Part marking:** There may be an additional marking, which relates to the logo, the lot trace code information, or the environmental category of the part.

Multiple part markings will be inside parentheses. Only one part marking contained in parentheses and separated by a "~" will appear on a part. If a line is indented then it is a continuation of the previous line and the two combined represent the entire part marking for that device.

Important Information and Disclaimer: The information provided on this page represents TI's knowledge and belief as of the date that it is provided. TI bases its knowledge and belief on information provided by third parties, and makes no representation or warranty as to the accuracy of such information. Efforts are underway to better integrate information from third parties. TI has taken and continues to take reasonable steps to provide representative and accurate information but may not have conducted destructive testing or chemical analysis on incoming materials and chemicals. TI and TI suppliers consider certain information to be proprietary, and thus CAS numbers and other limited information may not be available for release.

In no event shall TI's liability arising out of such information exceed the total purchase price of the TI part(s) at issue in this document sold by TI to Customer on an annual basis.

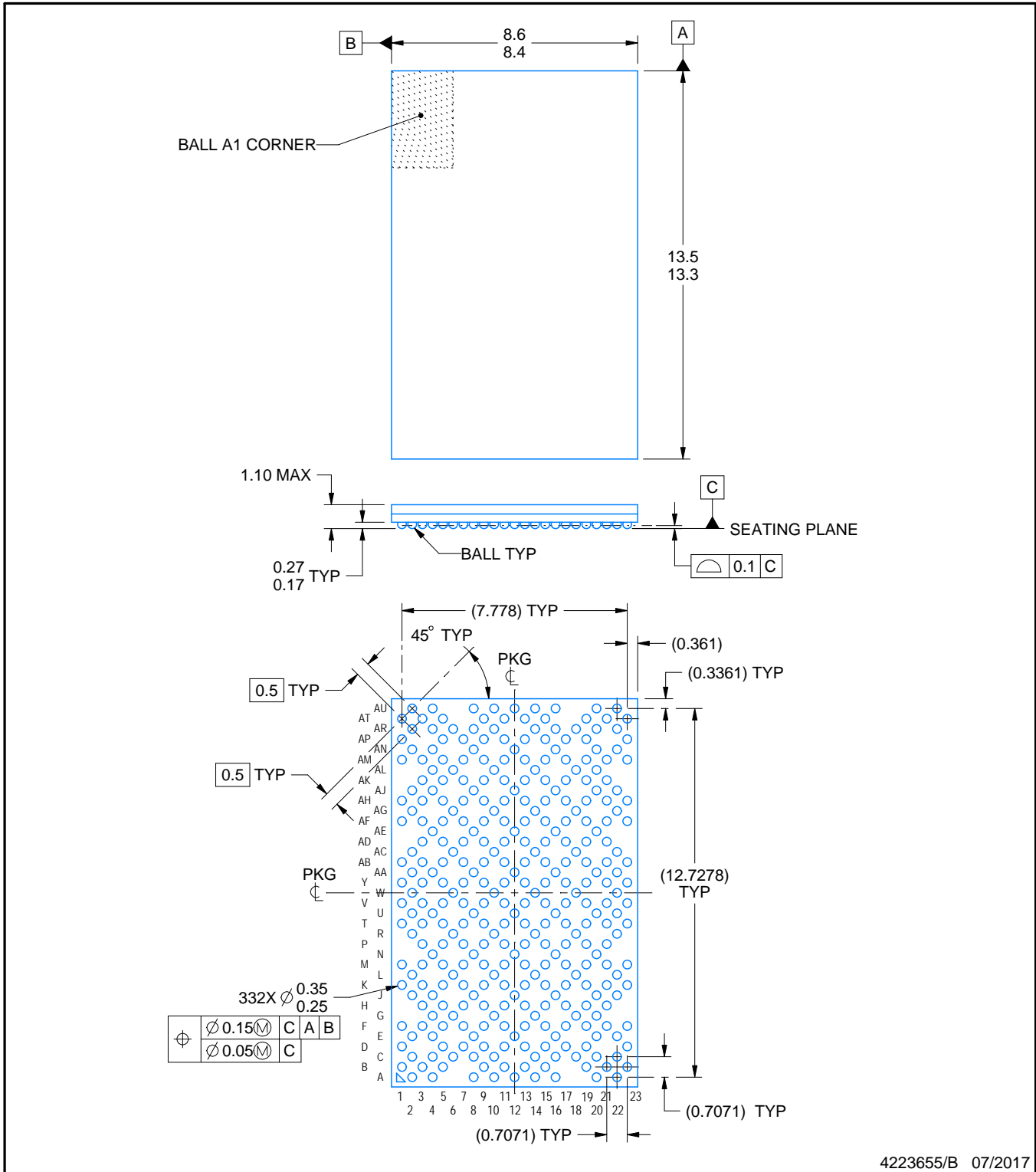

4223655/B 07/2017

NOTES:

1. All linear dimensions are in millimeters. Any dimensions in parenthesis are for reference only. Dimensioning and tolerancing per ASME Y14.5M.
2. This drawing is subject to change without notice.

EXAMPLE BOARD LAYOUT

ACB0332A

FCBGA - 1.10 mm max height

BALL GRID ARRAY

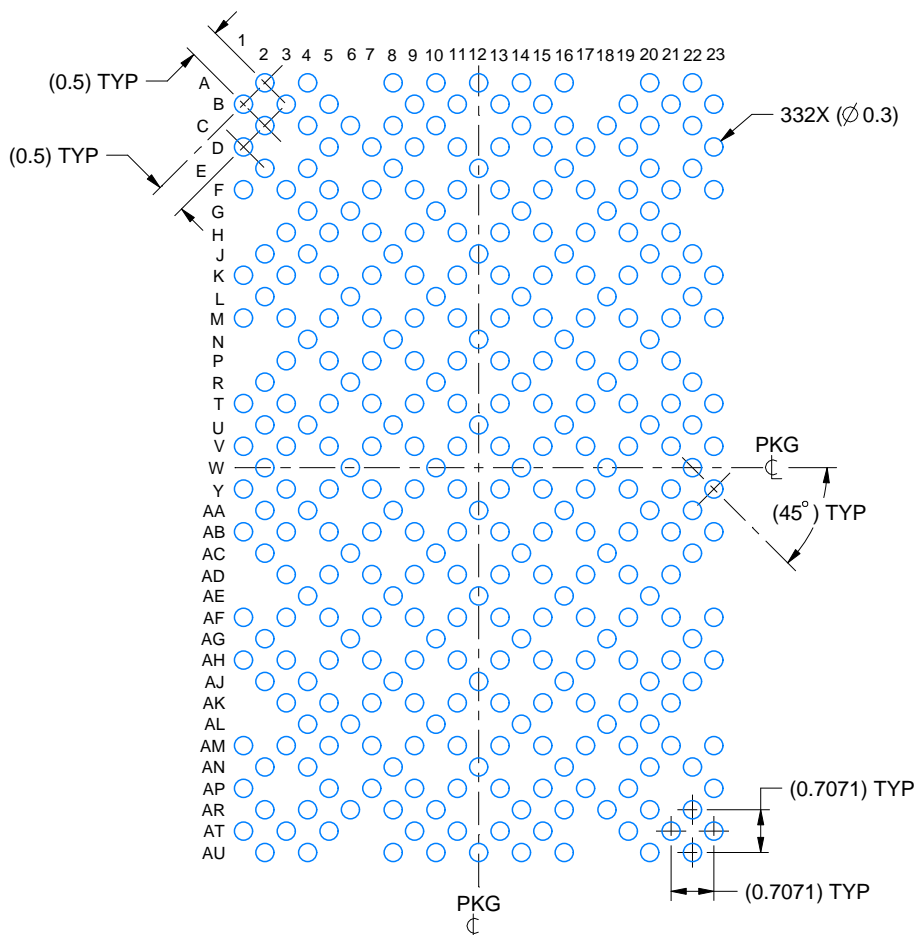

LAND PATTERN EXAMPLE
SCALE:8X

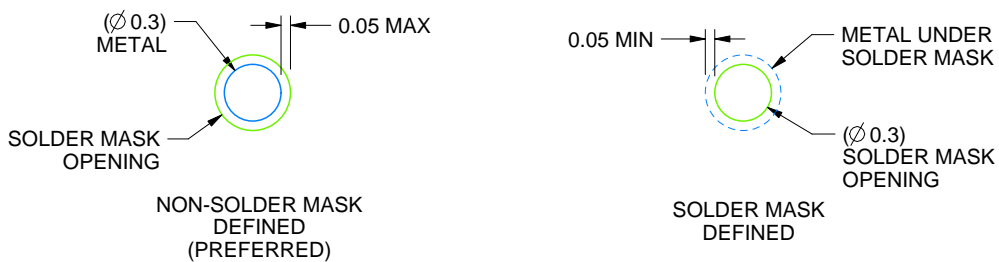

SOLDER MASK DETAILS
NOT TO SCALE

4223655/B 07/2017

NOTES: (continued)

- Final dimensions may vary due to manufacturing tolerance considerations and also routing constraints. For more information, see Texas Instruments literature number SPRU811 (www.ti.com/lit/spru811).

EXAMPLE STENCIL DESIGN

ACB0332A

FCBGA - 1.10 mm max height

BALL GRID ARRAY

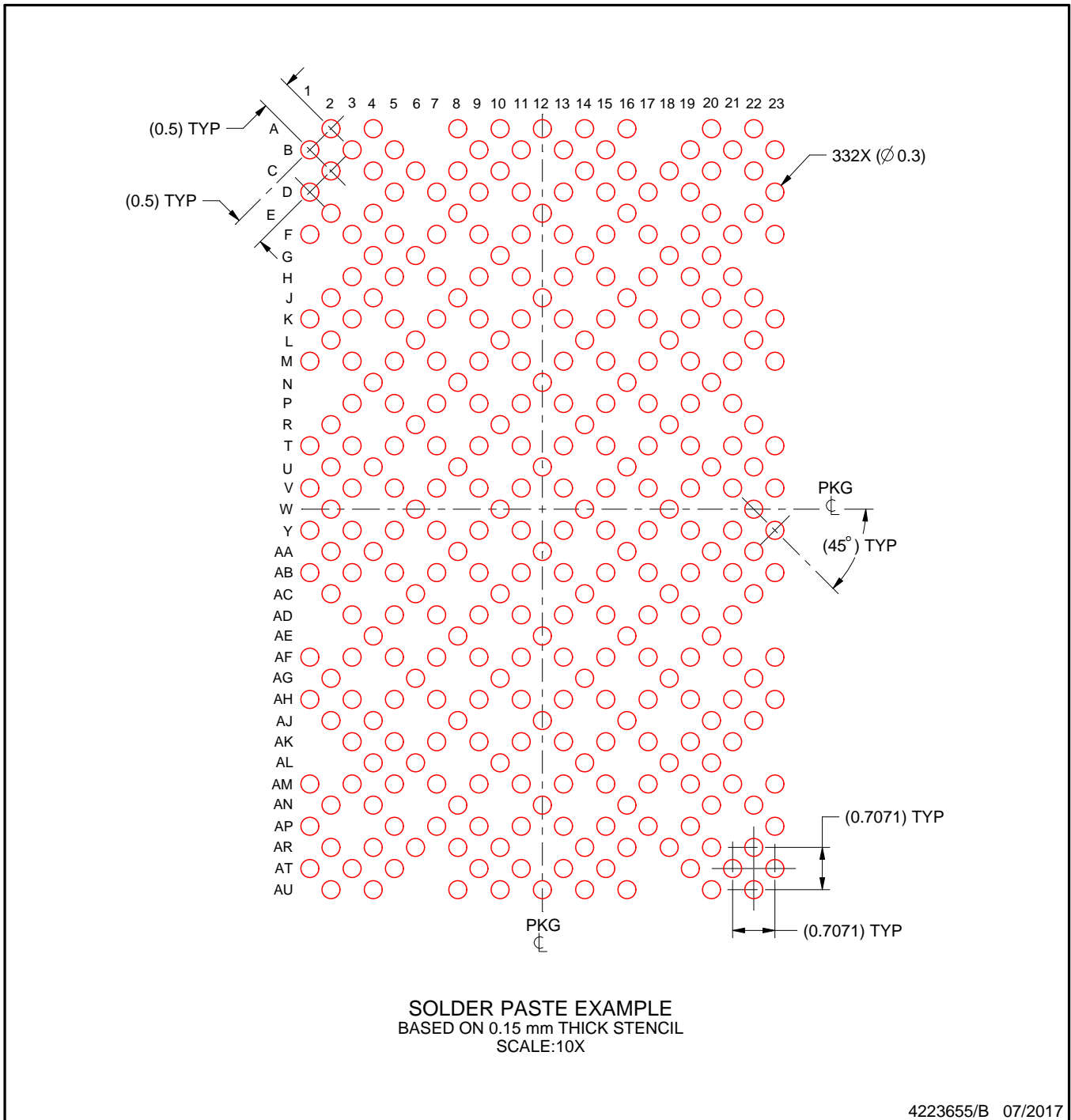

NOTES: (continued)

6. Laser cutting apertures with trapezoidal walls and rounded corners may offer better paste release.

IMPORTANT NOTICE AND DISCLAIMER

TI PROVIDES TECHNICAL AND RELIABILITY DATA (INCLUDING DATASHEETS), DESIGN RESOURCES (INCLUDING REFERENCE DESIGNS), APPLICATION OR OTHER DESIGN ADVICE, WEB TOOLS, SAFETY INFORMATION, AND OTHER RESOURCES "AS IS" AND WITH ALL FAULTS, AND DISCLAIMS ALL WARRANTIES, EXPRESS AND IMPLIED, INCLUDING WITHOUT LIMITATION ANY IMPLIED WARRANTIES OF MERCHANTABILITY, FITNESS FOR A PARTICULAR PURPOSE OR NON-INFRINGEMENT OF THIRD PARTY INTELLECTUAL PROPERTY RIGHTS.

These resources are intended for skilled developers designing with TI products. You are solely responsible for (1) selecting the appropriate TI products for your application, (2) designing, validating and testing your application, and (3) ensuring your application meets applicable standards, and any other safety, security, regulatory or other requirements.

These resources are subject to change without notice. TI grants you permission to use these resources only for development of an application that uses the TI products described in the resource. Other reproduction and display of these resources is prohibited. No license is granted to any other TI intellectual property right or to any third party intellectual property right. TI disclaims responsibility for, and you fully indemnify TI and its representatives against any claims, damages, costs, losses, and liabilities arising out of your use of these resources.

TI's products are provided subject to [TI's Terms of Sale](#), [TI's General Quality Guidelines](#), or other applicable terms available either on ti.com or provided in conjunction with such TI products. TI's provision of these resources does not expand or otherwise alter TI's applicable warranties or warranty disclaimers for TI products. Unless TI explicitly designates a product as custom or customer-specified, TI products are standard, catalog, general purpose devices.

TI objects to and rejects any additional or different terms you may propose.

Copyright © 2026, Texas Instruments Incorporated

Last updated 10/2025