

ESD2CAN36W-Q1 36V, 2-Channel ESD Protection Diode in DFN1110 Industry Standard Package for In-Vehicle Networks

1 Features

- IEC 61000-4-2 level 4 ESD protection:
 - $\pm 20\text{kV}$ contact discharge
 - $\pm 20\text{kV}$ air-gap discharge
- ISO 10605 (330pF, 330 Ω) ESD protection:
 - $\pm 19\text{kV}$ contact discharge
 - $\pm 19\text{kV}$ air-gap discharge
- Tested in compliance to IEC 61000-4-5
- 36V working voltage
- Bidirectional ESD protection
- 2-channel device provides complete ESD protection with single component
- Low clamping voltage protects downstream components
- AEC-Q101 qualified
- I/O capacitance = 3pF (typical)
- DFN1110 (DXA) small, standard, common footprint leadless package with side-wettable flanks for automatic optical inspection (AOI)

2 Applications

- **Automotive in-vehicle networks:**
 - Controller area network (CAN)
 - Controlled area network flexible data-rate (CAN-FD)
 - Low, fault tolerant CAN
 - High-speed CAN
- **Industrial control networks:**
 - DeviceNet IEC 62026-3
 - CANopen – CiA 301/302-2 and EN 50325-4

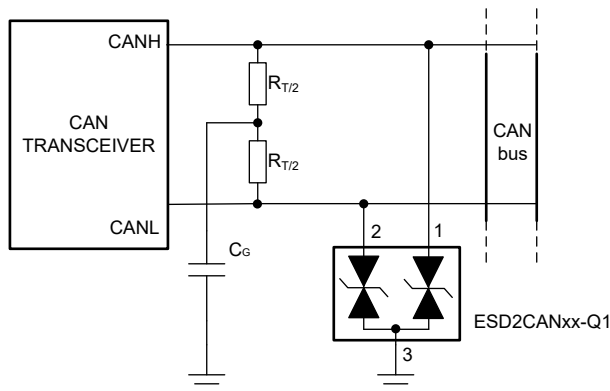

ESD2CAN36W-Q1 Typical Application

3 Description

ESD2CAN36W-Q1 is a bidirectional ESD protection diode for Controller Area Network (CAN) interface protection. ESD2CAN36W-Q1 is rated to dissipate contact ESD strikes specified in the IEC 61000-4-2 standard. The low dynamic resistance and low clamping voltage enables system level protection against transient events. This protection is key as automotive systems require a high level of robustness and reliability for safety applications.

This device features a low IO capacitance per channel and a pin-out to suit two automotive CAN bus lines (CANH and CANL) from the damage caused by ElectroStatic Discharge (ESD) and other transients. Additionally, the 3pF (typical) line capacitance of ESD2CAN36W-Q1 is designed for CAN, CANFD, CAN SiC, and CAN-XL applications that can support data rates up to 20Mbps.

Package Information

PART NUMBER	PACKAGE ⁽¹⁾	BODY SIZE (NOM)
ESD2CAN36W-Q1	DXA (DFN1110, 3)	1.1mm × 1.0mm

- (1) For all available packages, see the orderable addendum at the end of the data sheet.

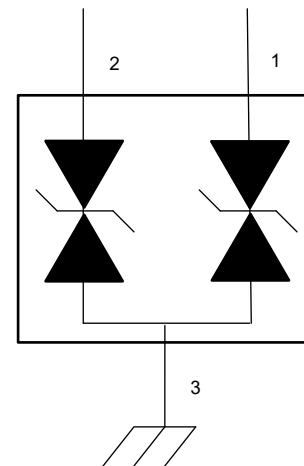

Functional Block Diagram



Table of Contents

1 Features	1	6.2 Typical Application.....	7
2 Applications	1	7 Layout	8
3 Description	1	7.1 Layout Guidelines.....	8
4 Pin Configuration and Functions	3	7.2 Layout Example.....	8
5 Specifications	4	8 Device and Documentation Support	9
5.1 Absolute Maximum Ratings.....	4	8.1 Documentation Support.....	9
5.2 ESD Ratings—AEC Specification.....	4	8.2 Receiving Notification of Documentation Updates.....	9
5.3 ESD Ratings—IEC Specification.....	4	8.3 Support Resources.....	9
5.4 ESD Ratings - ISO Specification.....	4	8.4 Trademarks.....	9
5.5 Recommended Operating Conditions.....	4	8.5 Electrostatic Discharge Caution.....	9
5.6 Thermal Information.....	5	8.6 Glossary.....	9
5.7 Electrical Characteristics.....	5	9 Revision History	9
5.8 Typical Characteristics.....	6	10 Mechanical, Packaging, and Orderable Information	9
6 Application and Implementation	7		
6.1 Application Information.....	7		

4 Pin Configuration and Functions

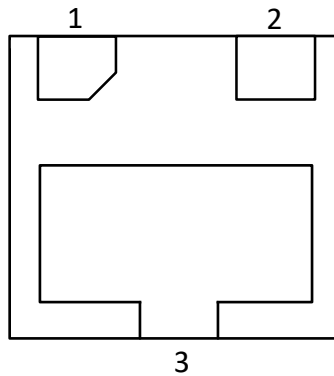

Figure 4-1. DXA Package, 3-Pin DFN1110 (Bottom View)

Pin Functions

PIN		TYPE ⁽¹⁾	DESCRIPTION
NAME	NO.		
IO	1, 2	I/O	ESD protected IO
GND	3	G	Connect to ground.

(1) I = Input, O = Output, I/O = Input or Output, G = Ground, P = Power

5 Specifications

5.1 Absolute Maximum Ratings

over operating free-air temperature range (unless otherwise noted)⁽¹⁾

		MIN	MAX	UNIT
Peak pulse	IEC 61000-4-5 Power ($t_p - 8/20\mu s$) at 25°C		233	W
	IEC 61000-4-5 current ($t_p - 8/20\mu s$) at 25°C		3.8	A
T_A	Operating free-air temperature	-55	150	°C
T_{stg}	Storage temperature	-65	155	°C

- (1) Stresses beyond those listed under *Absolute Maximum Ratings* may cause permanent damage to the device. These are stress ratings only, which do not imply functional operation of the device at these or any other conditions beyond those indicated under *Recommended Operating Conditions*. Exposure to absolute-maximum-rated conditions for extended periods may affect device reliability.

5.2 ESD Ratings—AEC Specification

			VALUE	UNIT
$V_{(ESD)}$	Electrostatic discharge	Human body model (HBM), per AEC Q101-001	± 2500	V
		Charged device model (CDM), per AEC Q101-005	± 1000	

5.3 ESD Ratings—IEC Specification

			VALUE	UNIT
$V_{(ESD)}$	Electrostatic discharge	IEC 61000-4-2 Contact Discharge, all pins	±20000	V
		IEC 61000-4-2 Air-gap Discharge, all pins	±20000	

5.4 ESD Ratings - ISO Specification

				VALUE	UNIT
$V_{(ESD)}$	Electrostatic discharge	ISO 10605, C=150pF, R=330Ω	Contact discharge	± 19000	V
			Air-gap discharge	± 19000	
		ISO 10605, C=330pF, R=330Ω	Contact discharge	± 19000	
			Air-gap discharge	± 19000	

5.5 Recommended Operating Conditions

over operating free-air temperature range (unless otherwise noted)

		MIN	NOM	MAX	UNIT
V_{IN}	Input voltage	-36		36	V
T_A	Operating free-air temperature	-55		150	°C

5.6 Thermal Information

THERMAL METRIC ⁽¹⁾		ESD2CAN36W-Q1	
		DXA (DFN1110-3)	
		3 PINS	
			UNIT
R _{θJA}	Junction-to-ambient thermal resistance	284.2	°C/W
R _{θJC(top)}	Junction-to-case (top) thermal resistance	147.9	°C/W
R _{θJB}	Junction-to-board thermal resistance	127.4	°C/W
Ψ _{JT}	Junction-to-top characterization parameter	12.0	°C/W
Ψ _{JB}	Junction-to-board characterization parameter	126.3	°C/W
R _{θJC(bot)}	Junction-to-case (bottom) thermal resistance	NA	°C/W

(1) For more information about traditional and new thermal metrics, see the [Semiconductor and IC Package Thermal Metrics](#) application note.

5.7 Electrical Characteristics

over T_A = 25°C (unless otherwise noted)

PARAMETER		TEST CONDITIONS	MIN	TYP	MAX	UNIT
V _{RWM}	Reverse stand-off voltage		-36		36	V
V _{BRF}	Breakdown voltage	I _{IO} = 10mA	37.8		44.2	V
V _{BRR}	Breakdown voltage	I _{IO} = -10mA	-44.2		-37.8	V
V _{CLAMP}	Clamping voltage ⁽¹⁾	I _{PP} = 3.8A, t _p = 8/20μs, from IO to GND		66		V
V _{CLAMP}	Clamping voltage ⁽²⁾	I _{PP} = 16A, TLP, from IO to GND, both Positive & Negative		65		V
I _{LEAK}	Leakage current, any IO pin to GND	V _{IO} = ±36V	-50	5	50	nA
R _{DYN}	Dynamic resistance ⁽²⁾	IO to GND		0.65		Ω
		GND to IO		0.65		
C _L	Line capacitance, any IO to GND	V _{IO} = 0V, f = 1MHz, V _{p-p} = 30mV		3	4	pF

(1) Device stressed with 8/20μs exponential decay waveform according to IEC 61000-4-5.

(2) Non-repetitive current pulse, Transmission Line Pulse (TLP); square pulse; ANSI / ESD STM5.5.1-2008

5.8 Typical Characteristics

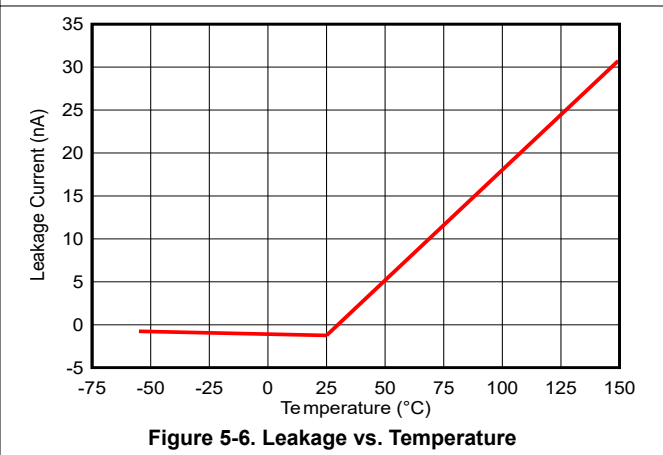
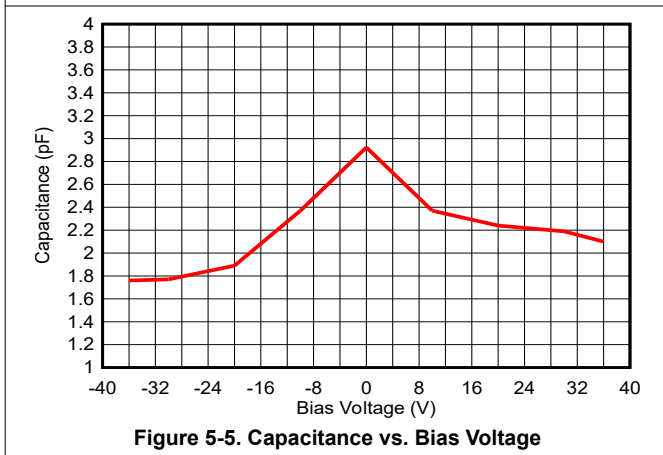
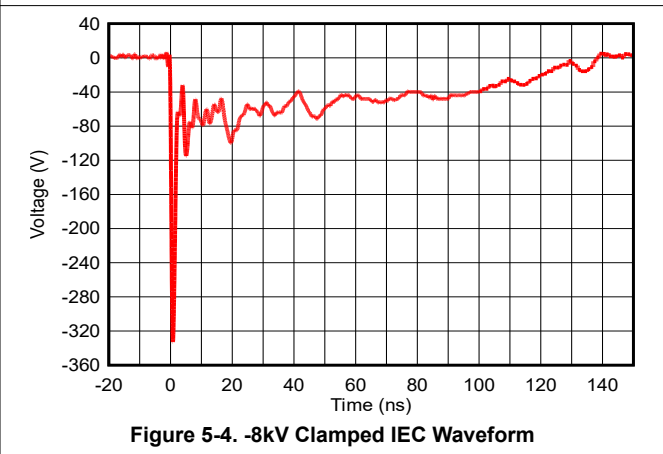
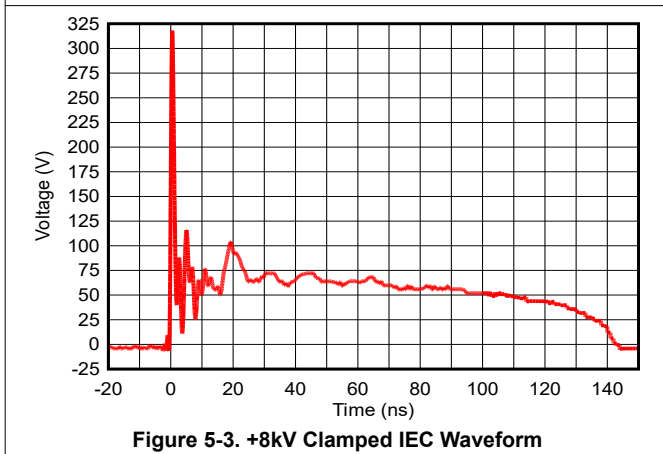
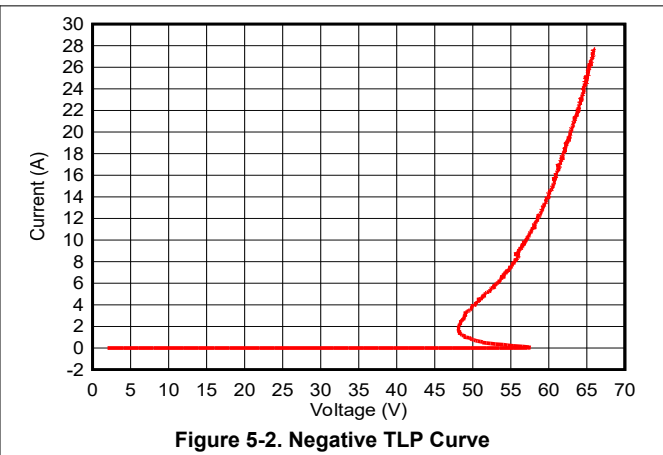
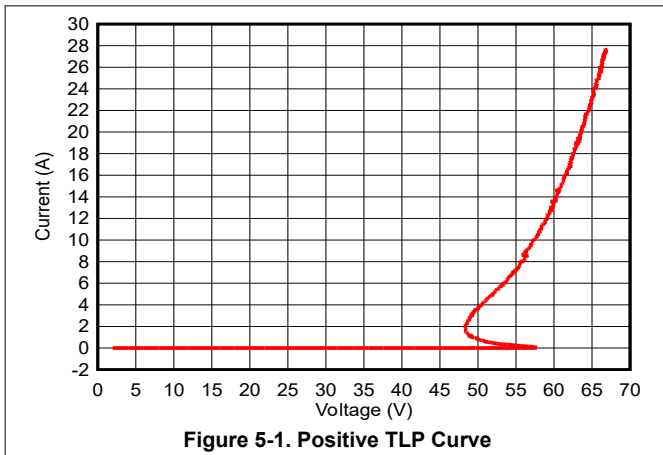

6 Application and Implementation

Note

Information in the following applications sections is not part of the TI component specification, and TI does not warrant its accuracy or completeness. TI's customers are responsible for determining suitability of components for their purposes, as well as validating and testing their design implementation to confirm system functionality.

6.1 Application Information

The ESD2CAN36W-Q1 is a dual channel TVS diode which is used to provide a path to ground for dissipating ESD events on differential CAN signal lines. The CAN signal lines are typically routed throughout the automobile to connect between the different ECUs. As the current from an ESD strike passes through the TVS diode, only a small voltage drop is present across the diode. This is the voltage presented to the protected IC. The low R_{DYN} of the triggered TVS diode holds this voltage, V_{CLAMP} , to a safe level for the protected IC.

6.2 Typical Application

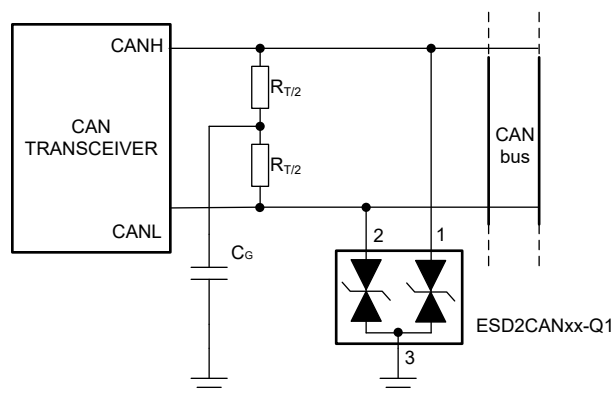

Figure 6-1. ESD2CAN36W-Q1 Typical Application

6.2.1 Detailed Design Procedure

The ESD2CAN36W-Q1 has a V_{RWM} of $\pm 36V$ to protect the diode from being damaged during a short to battery event that can occur by reversing the terminal connections during jumpstart. The bidirectional characteristic enables signal integrity across positive and negative signal inputs, as well as accounts for any line faults or miswiring. The low capacitance of 3pF (typical) enables data rates up to 20Mbps, which allows the designer to meet the requirements for CAN, CANFD, CAN SiC, and CAN-XL. The clamping voltage of this device can protect CAN transceivers with an absolute maximum rating of 70V up to the IEC61000-4-2 Level 4 standard. The 60 Ω split termination improves the electromagnetic emissions behavior of the network by filtering higher-frequency common-mode noise that may be present on the differential signal lines.

For additional information, please see the [CAN Bus ESD Protection Application Note](#).

7 Layout

7.1 Layout Guidelines

- The optimum placement of the device is as close to the connector as possible.
 - EMI during an ESD event can couple from the trace being struck to other nearby unprotected traces, resulting in early system failures.
 - The PCB designer must minimize the possibility of EMI coupling by keeping any unprotected traces away from the protected traces which are between the TVS and the connector.
- Route the protected traces as straight as possible.
- Eliminate any sharp corners on the protected traces between the TVS and the connector by using rounded corners with the largest radii possible.
 - Electric fields tend to build up on corners, increasing EMI coupling.
- If pin 3 is connected to ground, use a thick and short trace for this return path.

7.2 Layout Example

This example is typical of a dual channel differential data pair application, such as CAN.

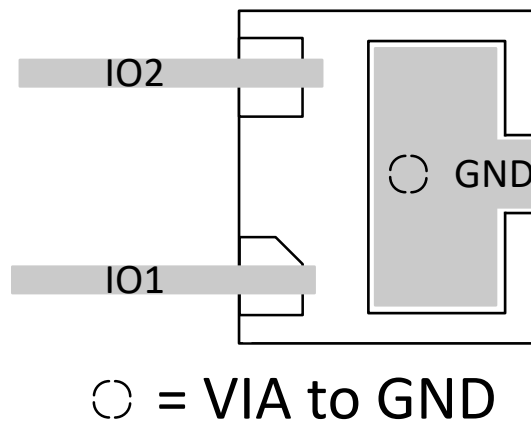

Figure 7-1. Routing with DXA Package

8 Device and Documentation Support

TI offers an extensive line of development tools. Tools and software to evaluate the performance of the device, generate code, and develop solutions are listed below.

8.1 Documentation Support

8.1.1 Related Documentation

For related documentation, see the following:

- Texas Instruments, [Protecting Automotive Can Bus Systems from ESD Overvoltage Events application note](#)
- Texas Instruments, [ESD Layout Guide user's guide](#)
- Texas Instruments, [ESD Protection Diodes EVM user's guide](#)
- Texas Instruments, [Generic ESD Evaluation Module user's guide](#)
- Texas Instruments, [Reading and Understanding an ESD Protection data sheet](#)

8.2 Receiving Notification of Documentation Updates

To receive notification of documentation updates, navigate to the device product folder on ti.com. Click on *Notifications* to register and receive a weekly digest of any product information that has changed. For change details, review the revision history included in any revised document.

8.3 Support Resources

TI E2E™ [support forums](#) are an engineer's go-to source for fast, verified answers and design help — straight from the experts. Search existing answers or ask your own question to get the quick design help you need.

Linked content is provided "AS IS" by the respective contributors. They do not constitute TI specifications and do not necessarily reflect TI's views; see TI's [Terms of Use](#).

8.4 Trademarks

TI E2E™ is a trademark of Texas Instruments.
All trademarks are the property of their respective owners.

8.5 Electrostatic Discharge Caution



This integrated circuit can be damaged by ESD. Texas Instruments recommends that all integrated circuits be handled with appropriate precautions. Failure to observe proper handling and installation procedures can cause damage.

ESD damage can range from subtle performance degradation to complete device failure. Precision integrated circuits may be more susceptible to damage because very small parametric changes could cause the device not to meet its published specifications.

8.6 Glossary

[TI Glossary](#) This glossary lists and explains terms, acronyms, and definitions.

9 Revision History

NOTE: Page numbers for previous revisions may differ from page numbers in the current version.

DATE	REVISION	NOTES
January 2026	*	Initial Release

10 Mechanical, Packaging, and Orderable Information

The following pages include mechanical, packaging, and orderable information. This information is the most current data available for the designated devices. This data is subject to change without notice and revision of this document. For browser-based versions of this data sheet, refer to the left-hand navigation.

PACKAGING INFORMATION

Orderable part number	Status (1)	Material type (2)	Package Pins	Package qty Carrier	RoHS (3)	Lead finish/ Ball material (4)	MSL rating/ Peak reflow (5)	Op temp (°C)	Part marking (6)
ESD2CAN36WDXARQ1	Active	Production	USON (DXA) 3	3000 LARGE T&R	Yes	SN	Level-1-260C-UNLIM	-55 to 150	1WN

(1) **Status:** For more details on status, see our [product life cycle](#).

(2) **Material type:** When designated, preproduction parts are prototypes/experimental devices, and are not yet approved or released for full production. Testing and final process, including without limitation quality assurance, reliability performance testing, and/or process qualification, may not yet be complete, and this item is subject to further changes or possible discontinuation. If available for ordering, purchases will be subject to an additional waiver at checkout, and are intended for early internal evaluation purposes only. These items are sold without warranties of any kind.

(3) **RoHS values:** Yes, No, RoHS Exempt. See the [TI RoHS Statement](#) for additional information and value definition.

(4) **Lead finish/Ball material:** Parts may have multiple material finish options. Finish options are separated by a vertical ruled line. Lead finish/Ball material values may wrap to two lines if the finish value exceeds the maximum column width.

(5) **MSL rating/Peak reflow:** The moisture sensitivity level ratings and peak solder (reflow) temperatures. In the event that a part has multiple moisture sensitivity ratings, only the lowest level per JEDEC standards is shown. Refer to the shipping label for the actual reflow temperature that will be used to mount the part to the printed circuit board.

(6) **Part marking:** There may be an additional marking, which relates to the logo, the lot trace code information, or the environmental category of the part.

Multiple part markings will be inside parentheses. Only one part marking contained in parentheses and separated by a "-" will appear on a part. If a line is indented then it is a continuation of the previous line and the two combined represent the entire part marking for that device.

Important Information and Disclaimer: The information provided on this page represents TI's knowledge and belief as of the date that it is provided. TI bases its knowledge and belief on information provided by third parties, and makes no representation or warranty as to the accuracy of such information. Efforts are underway to better integrate information from third parties. TI has taken and continues to take reasonable steps to provide representative and accurate information but may not have conducted destructive testing or chemical analysis on incoming materials and chemicals. TI and TI suppliers consider certain information to be proprietary, and thus CAS numbers and other limited information may not be available for release.

In no event shall TI's liability arising out of such information exceed the total purchase price of the TI part(s) at issue in this document sold by TI to Customer on an annual basis.

TAPE AND REEL INFORMATION

QUADRANT ASSIGNMENTS FOR PIN 1 ORIENTATION IN TAPE

*All dimensions are nominal

Device	Package Type	Package Drawing	Pins	SPQ	Reel Diameter (mm)	Reel Width W1 (mm)	A0 (mm)	B0 (mm)	K0 (mm)	P1 (mm)	W (mm)	Pin1 Quadrant
ESD2CAN36WDXARQ1	USON	DXA	3	3000	180.0	8.4	1.2	1.3	0.65	4.0	8.0	Q1

TAPE AND REEL BOX DIMENSIONS

*All dimensions are nominal

Device	Package Type	Package Drawing	Pins	SPQ	Length (mm)	Width (mm)	Height (mm)
ESD2CAN36WDXARQ1	USON	DXA	3	3000	210.0	185.0	35.0

DXA0003A



PACKAGE OUTLINE

USON - 0.55 mm max height

PLASTIC QUAD FLATPACK - NO LEAD

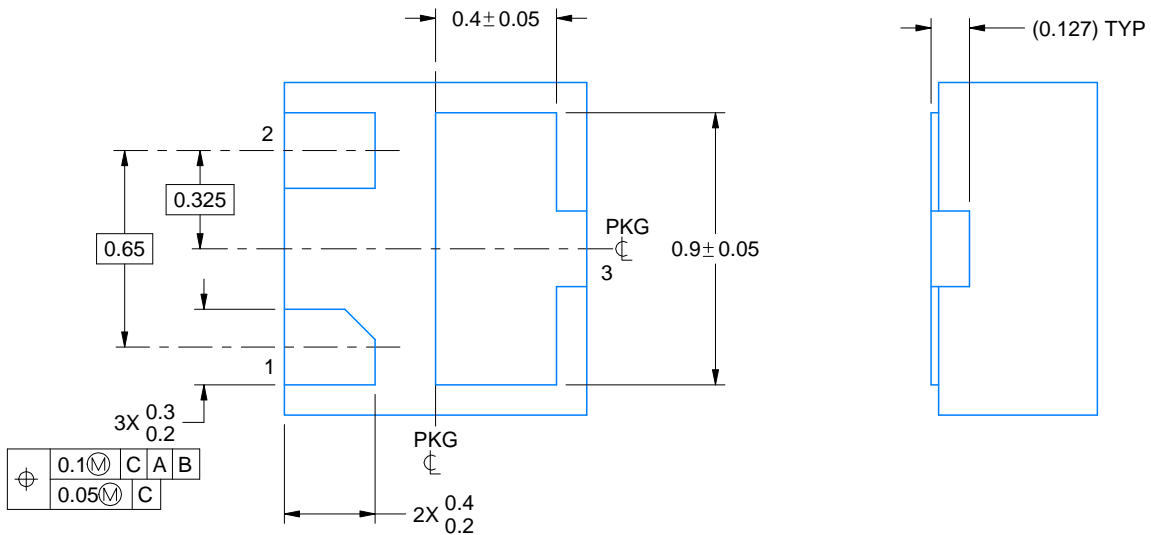
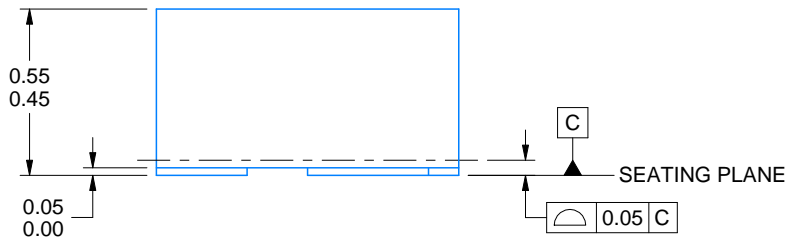
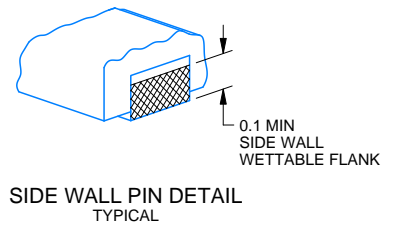
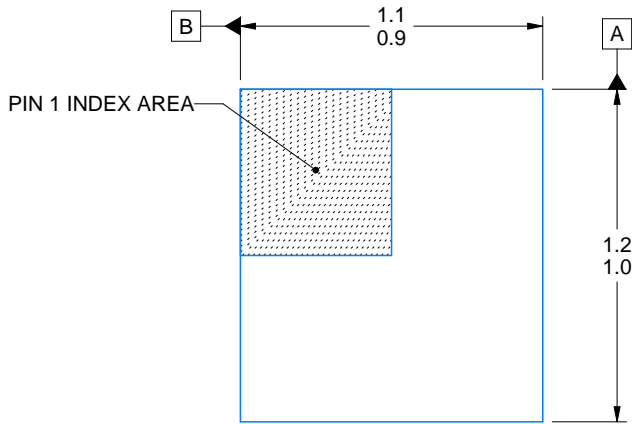

4231399/A 12/2024

NOTES:

1. All linear dimensions are in millimeters. Any dimensions in parenthesis are for reference only. Dimensioning and tolerancing per ASME Y14.5M.
2. This drawing is subject to change without notice.

EXAMPLE BOARD LAYOUT

DXA0003A

USON - 0.55 mm max height

PLASTIC QUAD FLATPACK - NO LEAD

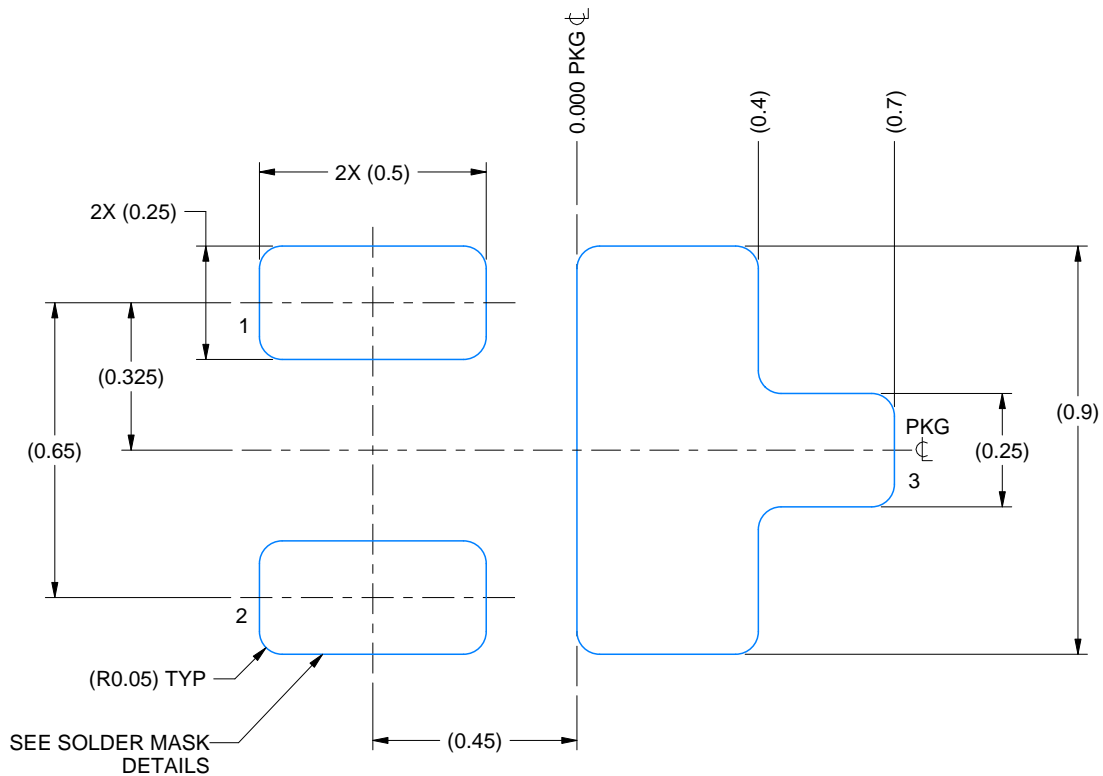

LAND PATTERN EXAMPLE
EXPOSED METAL SHOWN
SCALE: 60X

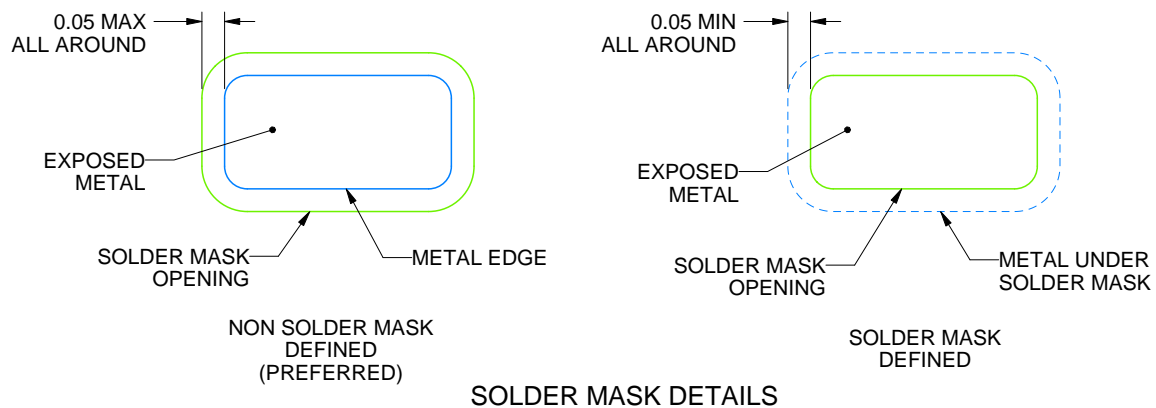

SOLDER MASK DETAILS

4231399/A 12/2024

NOTES: (continued)

3. For more information, see Texas Instruments literature number SLUA271 (www.ti.com/lit/sluea271).

EXAMPLE STENCIL DESIGN

DXA0003A

USON - 0.55 mm max height

PLASTIC QUAD FLATPACK - NO LEAD

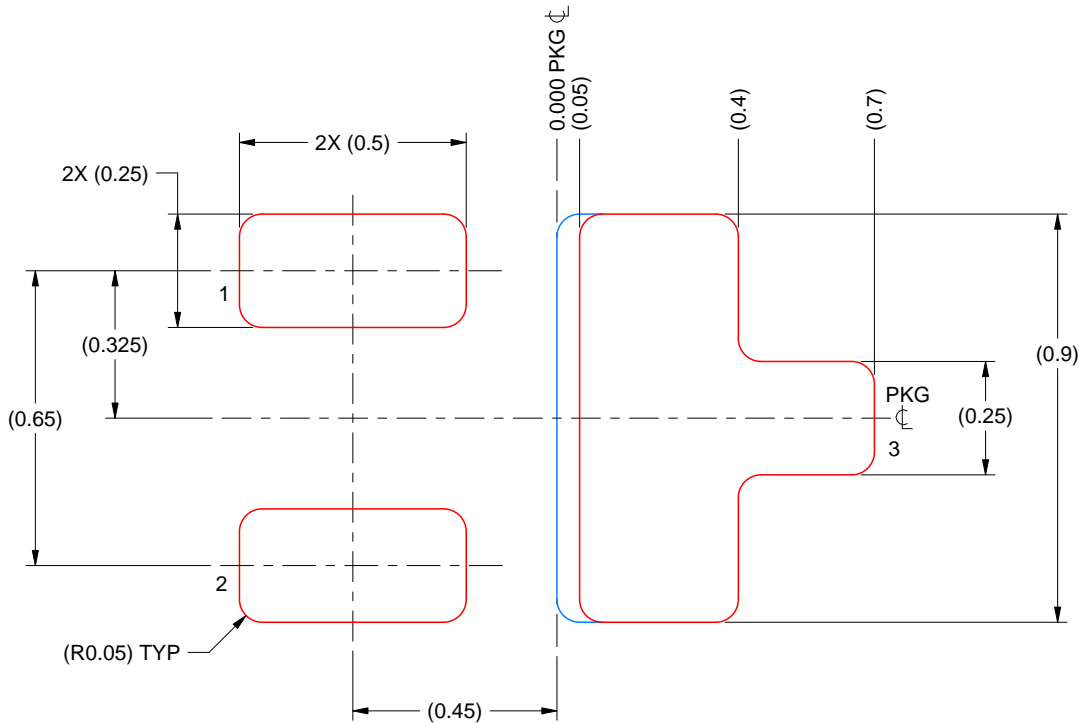

SOLDER PASTE EXAMPLE
BASED ON 0.1 mm THICK STENCIL
SCALE: 60X
EXPOSED PAD 3
90% PRINTED SOLDER COVERAGE BY AREA UNDER PACKAGE

4231399/A 12/2024

NOTES: (continued)

4. Laser cutting apertures with trapezoidal walls and rounded corners may offer better paste release. IPC-7525 may have alternate design recommendations.

IMPORTANT NOTICE AND DISCLAIMER

TI PROVIDES TECHNICAL AND RELIABILITY DATA (INCLUDING DATASHEETS), DESIGN RESOURCES (INCLUDING REFERENCE DESIGNS), APPLICATION OR OTHER DESIGN ADVICE, WEB TOOLS, SAFETY INFORMATION, AND OTHER RESOURCES "AS IS" AND WITH ALL FAULTS, AND DISCLAIMS ALL WARRANTIES, EXPRESS AND IMPLIED, INCLUDING WITHOUT LIMITATION ANY IMPLIED WARRANTIES OF MERCHANTABILITY, FITNESS FOR A PARTICULAR PURPOSE OR NON-INFRINGEMENT OF THIRD PARTY INTELLECTUAL PROPERTY RIGHTS.

These resources are intended for skilled developers designing with TI products. You are solely responsible for (1) selecting the appropriate TI products for your application, (2) designing, validating and testing your application, and (3) ensuring your application meets applicable standards, and any other safety, security, regulatory or other requirements.

These resources are subject to change without notice. TI grants you permission to use these resources only for development of an application that uses the TI products described in the resource. Other reproduction and display of these resources is prohibited. No license is granted to any other TI intellectual property right or to any third party intellectual property right. TI disclaims responsibility for, and you fully indemnify TI and its representatives against any claims, damages, costs, losses, and liabilities arising out of your use of these resources.

TI's products are provided subject to [TI's Terms of Sale](#), [TI's General Quality Guidelines](#), or other applicable terms available either on [ti.com](#) or provided in conjunction with such TI products. TI's provision of these resources does not expand or otherwise alter TI's applicable warranties or warranty disclaimers for TI products. Unless TI explicitly designates a product as custom or customer-specified, TI products are standard, catalog, general purpose devices.

TI objects to and rejects any additional or different terms you may propose.

Copyright © 2026, Texas Instruments Incorporated

Last updated 10/2025