

# INA185-Q1 AEC-Q100, 26V, 350kHz, Bidirectional, High-Precision Current Sense Amplifier

## 1 Features

- AEC-Q100 qualified for automotive applications
  - Temperature grade 1:  $-40^{\circ}\text{C} \leq T_A \leq 125^{\circ}\text{C}$
  - HBM ESD classification level 2
  - CDM ESD classification level C6
- **Functional Safety-Capable**
  - [Documentation available to aid functional safety system design](#)
- Common-mode range ( $V_{CM}$ ):  $-0.2\text{V}$  to  $26\text{V}$
- High bandwidth: 350kHz (A1 devices)
- Offset voltage:
  - $\pm 55\mu\text{V}$  (maximum) at  $V_{CM} = 0\text{V}$
  - $\pm 100\mu\text{V}$  (maximum) at  $V_{CM} = 12\text{V}$  (A4 device)
- Output slew rate:  $2\text{V}/\mu\text{s}$
- Bidirectional current-sensing capability
- Accuracy:
  - Maximum gain error (A1, A2, A3):  $\pm 0.2\%$
  - Maximum offset drift:  $0.5\mu\text{V}/^{\circ}\text{C}$
- Gain options:
  - $20\text{V}/\text{V}$  (A1 devices)
  - $50\text{V}/\text{V}$  (A2 devices)
  - $100\text{V}/\text{V}$  (A3 devices)
  - $200\text{V}/\text{V}$  (A4 devices)
- Quiescent current:  $260\mu\text{A}$  (maximum)

## 2 Applications

- [Body Control Modules](#)
- [Zonal Control Modules](#)
- [ADAS Domain Controllers](#)
- [ADAS Sensor Diagnostics](#)

## 3 Description

The INA185-Q1 current sense amplifier is designed for use in cost-sensitive space constrained applications. This device is a bidirectional, current-sense amplifier (also called a current-shunt monitor) that senses the voltage drop across a current-sense resistor at common-mode voltages from  $-0.2\text{V}$  to  $26\text{V}$ , independent of the supply voltage. The INA185-Q1 integrates a matched resistor gain network in four, fixed-gain device options:  $20\text{V}/\text{V}$ ,  $50\text{V}/\text{V}$ ,  $100\text{V}/\text{V}$ , or  $200\text{V}/\text{V}$ . This matched gain resistor network minimizes gain error and reduces the temperature drift.

The INA185-Q1 operates from a single  $2.7\text{V}$  to  $5.5\text{V}$  power supply. The device draws a maximum supply current of  $260\mu\text{A}$  and features high slew rate and bandwidth making this device an excellent choice for many power-supply and motor-control applications.

The INA185-Q1 is available in an industry standard SC70 package. The device is specified over the extended operating temperature range of  $-40^{\circ}\text{C}$  to  $125^{\circ}\text{C}$ .

### Package Information

PART NUMBER	PACKAGE <sup>(1)</sup>	PACKAGE SIZE <sup>(2)</sup>
INA185-Q1	DCK (SC70, 6)	2.00mm × 2.10mm

- (1) For all available packages, see [Section 10](#).
- (2) The package size (length × width) is a nominal value and includes pins, where applicable.

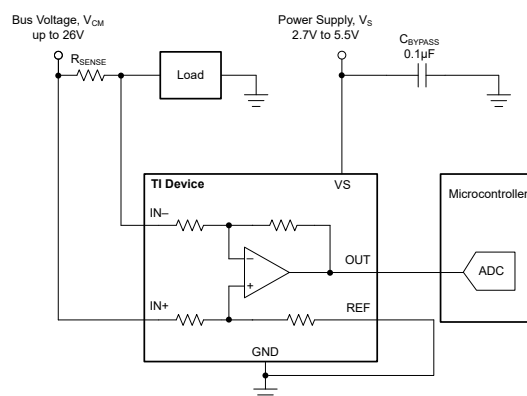

Typical Application Circuit

## Table of Contents

<b>1 Features</b> .....	1	7.1 Application Information.....	11
<b>2 Applications</b> .....	1	7.2 Typical Application.....	15
<b>3 Description</b> .....	1	7.3 Power Supply Recommendations.....	17
<b>4 Pin Configuration and Functions</b> .....	3	7.4 Layout.....	18
<b>5 Specifications</b> .....	4	<b>8 Device and Documentation Support</b> .....	19
5.1 Absolute Maximum Ratings .....	4	8.1 Device Support.....	19
5.2 ESD Ratings.....	4	8.2 Documentation Support.....	19
5.3 Recommended Operating Conditions.....	4	8.3 Receiving Notification of Documentation Updates...	19
5.4 Thermal Information.....	4	8.4 Support Resources.....	19
5.5 Electrical Characteristics.....	5	8.5 Trademarks.....	19
<b>6 Detailed Description</b> .....	6	8.6 Electrostatic Discharge Caution.....	19
6.1 Overview.....	6	8.7 Glossary.....	19
6.2 Functional Block Diagrams.....	6	<b>9 Revision History</b> .....	19
6.3 Feature Description.....	6	<b>10 Mechanical, Packaging, and Orderable</b>	
6.4 Device Functional Modes.....	8	<b>Information</b> .....	19
<b>7 Application and Implementation</b> .....	11		

## 4 Pin Configuration and Functions

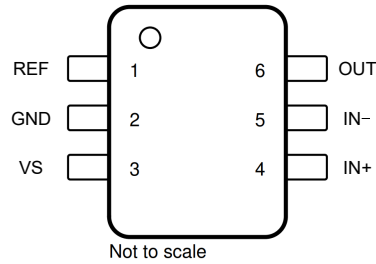

**Figure 4-1. INA185: DCK Package 6-Pin SC70 Top View**

**Table 4-1. Pin Functions**

PIN		TYPE	DESCRIPTION
NAME	SC70		
GND	2	Analog	Ground
IN-	5	Analog input	Current-sense amplifier negative input. For high-side applications, connect to load side of sense resistor. For low-side applications, connect to ground side of sense resistor.
IN+	4	Analog input	Current-sense amplifier positive input. For high-side applications, connect to bus-voltage side of sense resistor. For low-side applications, connect to load side of sense resistor.
OUT	6	Analog output	Output voltage
REF	1	Analog input	Reference input
VS	3	Analog	Power supply, 2.7V to 5.5V

## 5 Specifications

### 5.1 Absolute Maximum Ratings

over operating free-air temperature range (unless otherwise noted)<sup>(1)</sup>

		MIN	MAX	UNIT
V <sub>S</sub>	Supply voltage		6	V
	Analog inputs, IN+, IN- <sup>(2)</sup>	Differential (V <sub>IN+</sub> ) – (V <sub>IN-</sub> )	-28	28
		Common-mode <sup>(3)</sup>	GND – 0.3	28
V <sub>REF</sub>	Reference voltage	GND – 0.3	V <sub>S</sub> + 0.3	V
V <sub>OUT</sub>	Output voltage <sup>(3)</sup>	GND – 0.3	V <sub>S</sub> + 0.3	V
T <sub>A</sub>	Operating temperature	-55	150	°C
T <sub>J</sub>	Junction temperature		150	°C
T <sub>stg</sub>	Storage temperature	-65	150	°C

- (1) Stresses beyond those listed under *Absolute Maximum Ratings* may cause permanent damage to the device. These are stress ratings only, which do not imply functional operation of the device at these or any other conditions beyond those indicated under *Recommended Operating Conditions*. Exposure to absolute-maximum-rated conditions for extended periods may affect device reliability.
- (2) V<sub>IN+</sub> and V<sub>IN-</sub> are the voltages at the IN+ and IN- pins, respectively.
- (3) Input voltage at any pin can exceed the voltage shown if the current at that pin is limited to 5 mA.

### 5.2 ESD Ratings

			VALUE	UNIT
V <sub>(ESD)</sub>	Electrostatic discharge	Human-body model (HBM), per ANSI/ESDA/JEDEC JS-001 <sup>(1)</sup>	±3000	V
		Charged-device model (CDM), per JEDEC specification JESD22-C101 <sup>(2)</sup>	±1000	

- (1) JEDEC document JEP155 states that 500-V HBM allows safe manufacturing with a standard ESD control process.
- (2) JEDEC document JEP157 states that 250-V CDM allows safe manufacturing with a standard ESD control process.

### 5.3 Recommended Operating Conditions

over operating free-air temperature range (unless otherwise noted)

		MIN	NOM	MAX	UNIT
V <sub>CM</sub>	Common-mode input voltage	-0.2	12	26	V
V <sub>S</sub>	Operating supply voltage	2.7	5	5.5	V
T <sub>A</sub>	Operating free-air temperature	-40		125	°C

### 5.4 Thermal Information

THERMAL METRIC <sup>(1)</sup>		INA185-Q1
		DCK (SC70)
		6 PINS
R <sub>θJA</sub>	Junction-to-ambient thermal resistance	188.0
R <sub>θJC(top)</sub>	Junction-to-case (top) thermal resistance	140.8
R <sub>θJB</sub>	Junction-to-board thermal resistance	78.8
ψ <sub>JT</sub>	Junction-to-top characterization parameter	62.1
ψ <sub>JB</sub>	Junction-to-board characterization parameter	78.5
R <sub>θJC(bot)</sub>	Junction-to-case (bottom) thermal resistance	N/A

- (1) For more information about traditional and new thermal metrics, see the [Semiconductor and IC Package Thermal Metrics application report](#).

## 5.5 Electrical Characteristics

at  $T_A = 25^\circ\text{C}$ ,  $V_{\text{SENSE}} = V_{\text{IN}+} - V_{\text{IN}-}$ ,  $V_S = 5\text{V}$ ,  $V_{\text{REF}} = V_S / 2$ , and  $V_{\text{IN}+} = 12\text{V}$  (unless otherwise noted)

PARAMETER		CONDITIONS		MIN	TYP	MAX	UNIT
<b>INPUT</b>							
CMRR	Common-mode rejection ratio, RTI <sup>(1)</sup>	$V_{\text{IN}+} = 0\text{V to } 26\text{V}$ , $V_{\text{SENSE}} = 0\text{mV}$ , $T_A = -40^\circ\text{C to } 125^\circ\text{C}$	A1 device	86	100		dB
			A2, A3 devices	96	100		
			A4 devices	106	120		
V <sub>OS</sub>	Offset voltage, RTI	$V_{\text{SENSE}} = 0\text{mV}$ , $V_{\text{IN}+} = 0\text{V}$	A1 devices		±25	±135	µV
			A2, A3, A4 devices		±5	±55	
			A1 devices		±100	±450	
			A2, A3 devices		±25	±130	
			A4 device		±25	±100	
dV <sub>OS</sub> /dT	Offset drift, RTI	$V_{\text{SENSE}} = 0\text{mV}$ , $T_A = -40^\circ\text{C to } 125^\circ\text{C}$		0.2	0.5	µV/°C	
PSRR	Power supply rejection ratio, RTI	$V_S = 2.7\text{V to } 5.5\text{V}$ , $V_{\text{IN}+} = 12\text{V}$ , $V_{\text{SENSE}} = 0\text{mV}$		±8	±30	µV/V	
I <sub>IB</sub>	Input bias current	$V_{\text{SENSE}} = 0\text{mV}$ , $V_{\text{CM}} = 0\text{V}$			-6		µA
					75		
I <sub>IO</sub>	Input offset current	$V_{\text{SENSE}} = 0\text{mV}$			±0.05		µA
<b>OUTPUT</b>							
G	Gain		A1 devices		20		V/V
			A2 devices		50		
			A3 devices		100		
			A4 devices		200		
E <sub>G</sub>	Gain error	$V_{\text{OUT}} = 0.5\text{V to } V_S - 0.5\text{V}$ , $T_A = -40^\circ\text{C to } 125^\circ\text{C}$	A1, A2, A3 devices		±0.05%	±0.2%	
			A4 device		±0.07%	±0.25%	
	Gain error drift	$T_A = -40^\circ\text{C to } 125^\circ\text{C}$			1.5	8	ppm/°C
	Nonlinearity error	$V_{\text{OUT}} = 0.5\text{V to } V_S - 0.5\text{V}$			±0.01%		
	Maximum capacitive load	No sustained oscillation			1		nF
<b>VOLTAGE OUTPUT <sup>(2)</sup></b>							
V <sub>SP</sub>	Swing to V <sub>S</sub>	$R_L = 10\text{k}\Omega$ to GND, $T_A = -40^\circ\text{C to } 125^\circ\text{C}$			(V+) – 0.02	(V+) – 0.026	V
V <sub>SN</sub>	Swing to GND	$R_L = 10\text{k}\Omega$ to GND, $V_{\text{IN}+} - V_{\text{IN}-} = -10\text{mV}$ , $T_A = -40^\circ\text{C to } 125^\circ\text{C}$			(V <sub>GND</sub> ) + 0.0005	(V <sub>GND</sub> ) + 0.0035	V
V <sub>SG</sub>	Zero current swing to GND	$R_L = \text{Open}$ , $V_{\text{IN}+} - V_{\text{IN}-} = 0\text{mV}$ , $V_{\text{REF}} = 0\text{V}$ , $T_A = -40^\circ\text{C to } 125^\circ\text{C}$	A1 devices		(V <sub>GND</sub> ) + 0.0005	(V <sub>GND</sub> ) + 0.006	V
			A2, A3, A4 devices		(V <sub>GND</sub> ) + 0.0005	(V <sub>GND</sub> ) + 0.012	
<b>FREQUENCY RESPONSE</b>							
BW	Bandwidth	C <sub>LOAD</sub> = 10pF	A1 devices		350		kHz
			A2 devices		210		
			A3 devices		150		
			A4 devices		105		
SR	Slew rate				2		V/µs
<b>NOISE, RTI <sup>(1)</sup></b>							
	Voltage noise density				40		nV/√Hz
<b>POWER SUPPLY</b>							
I <sub>Q</sub>	Quiescent current	$V_{\text{SENSE}} = 0\text{mV}$			200	260	µA
		$V_{\text{SENSE}} = 0\text{mV}$ , $T_A = -40^\circ\text{C to } 125^\circ\text{C}$				300	

(1) RTI = referred-to-input.

(2) See Typical Characteristic curve, *Output Voltage Swing vs Output Current*

## 6 Detailed Description

### 6.1 Overview

The INA185-Q1 is a 26V common-mode current-sensing amplifier used in both low-side and high-side configurations. This specially-designed, current-sensing amplifier accurately measures voltages developed across current-sensing resistors on common-mode voltages that far exceed the supply voltage powering the device. Current can be measured on input voltage rails as high as 26V, and the device can be powered from supply voltages as low as 2.7V.

### 6.2 Functional Block Diagrams

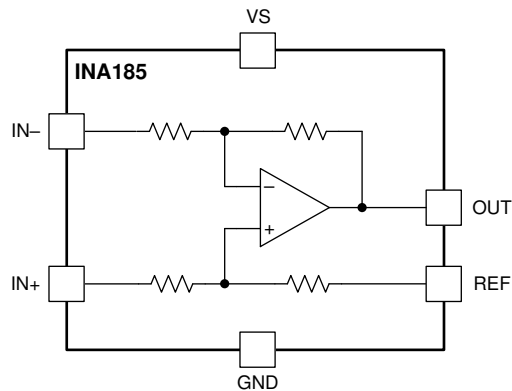

### 6.3 Feature Description

#### 6.3.1 High Bandwidth and Slew Rate

The INA185-Q1 supports small-signal bandwidths as high as 350kHz, and large-signal slew rates of 2V/μs. The ability to detect rapid changes in the sensed current, as well as the ability to quickly slew the output, make the INA185-Q1 a good choice for applications that require a quick response to input current changes. One application that requires high bandwidth and slew rate is low-side motor control, where the ability to follow rapid changing current in the motor allows for more accurate control over a wider operating range. Another application that requires higher bandwidth and slew rates is system fault detection, where the INA185-Q1 is used with an external comparator and a reference to quickly detect when the sensed current is out of range.

#### 6.3.2 Bidirectional Current Monitoring

The INA185-Q1 senses current flow through a sense resistor in both directions. The bidirectional current-sensing capability is achieved by applying a voltage at the REF pin to offset the output voltage. A positive differential voltage sensed at the inputs results in an output voltage that is greater than the applied reference voltage. Likewise, a negative differential voltage at the inputs results in output voltage that is less than the applied reference voltage. Use [Equation 1](#) to calculate the output voltage of the current-sense amplifier.

$$V_{\text{OUT}} = (I_{\text{LOAD}} \times R_{\text{SENSE}} \times \text{GAIN}) + V_{\text{REF}} \quad (1)$$

where

- $I_{\text{LOAD}}$  is the load current to be monitored.
- $R_{\text{SENSE}}$  is the current-sense resistor.
- GAIN is the gain option of the selected device.
- $V_{\text{REF}}$  is the voltage applied to the REF pin.

### 6.3.3 Wide Input Common-Mode Voltage Range

The INA185-Q1 supports input common-mode voltages from  $-0.2\text{V}$  to  $26\text{V}$ . Due to the internal topology, the common-mode range is not restricted by the power-supply voltage ( $V_S$ ) as long as  $V_S$  stays within the operational range of  $2.7\text{V}$  to  $5.5\text{V}$ . The ability to operate with common-mode voltages greater or less than  $V_S$  allows the INA185-Q1 to be used in high-side, as well as low-side, current-sensing applications, as shown in Figure 6-1.

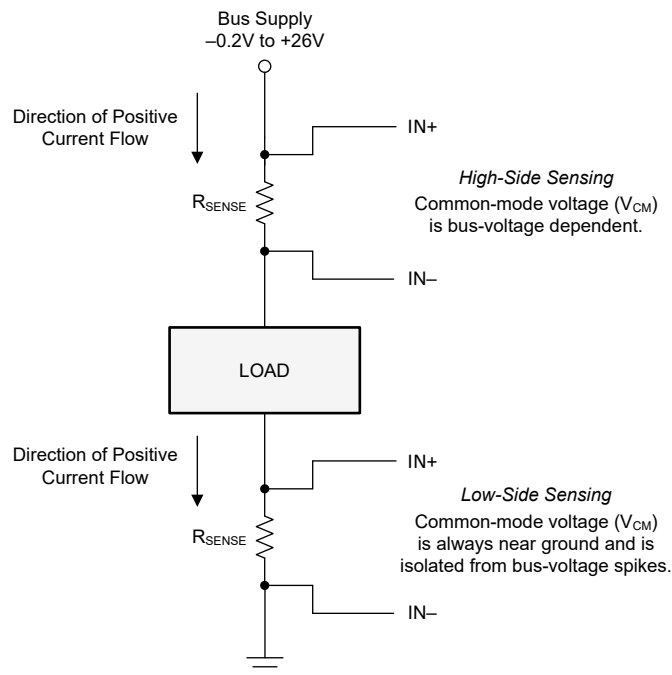

Figure 6-1. High-Side and Low-Side Sensing Connections

### 6.3.4 Precise Low-Side Current Sensing

When used in low-side current sensing applications, the offset voltage of the INA185-Q1 is within  $\pm 55\mu\text{V}$  for A2, A3 and A4 devices. The low offset performance of the INA185-Q1 has two main benefits. First, the low offset allows these devices to be used in applications that must measure current over a wide dynamic range. In this case, the low offset improves the accuracy when the sensed currents are on the low end of the measurement range. The other advantage of low offset is the ability to sense lower voltage drop across the sense resistor accurately, thus allowing a lower-value shunt resistor. Lower-value shunt resistors reduce power loss in the current sense circuit, and help improve the power efficiency of the end application.

The gain error of the INA185-Q1 is specified to be within 0.2% of the actual value for A1, A2, and A3 devices. As the sensed voltage becomes much larger than the offset voltage, this voltage becomes the dominant source of error in the current sense measurement.

### 6.3.5 Rail-to-Rail Output Swing

The INA185-Q1 allows linear current sensing operation with the output close to the supply rail and GND. The maximum specified output swing to the positive rail is  $25\text{mV}$ , and the maximum specified output swing to GND is only  $3.5\text{mV}$ . To compare the output swing of the INA185-Q1 to an equivalent operational amplifier (op amp), the inputs are overdriven to approximate the open-loop condition specified in many operational amplifier data sheets. The current-sense amplifier is a closed-loop system, therefore the output swing to GND can be limited by the offset voltage and amplifier gain during unidirectional operation ( $V_{\text{REF}} = 0\text{V}$ ) when there is zero current flowing through the sense resistor. To define the maximum output voltage under the zero current condition, the INA185-Q1 *Electrical Characteristics* table specifies a maximum output voltage of  $6\text{mV}$  for the A1 device, and  $12\text{mV}$  for all other devices.

## 6.4 Device Functional Modes

### 6.4.1 Normal Mode

The INA185-Q1 is in normal operation when the following conditions are met:

- The power supply voltage ( $V_S$ ) is between 2.7V and 5.5V.
- The common-mode voltage ( $V_{CM}$ ) is within the specified range of  $-0.2V$  to  $26V$ .
- The maximum differential input signal multiplied by the gain plus  $V_{REF}$  is less than  $V_S$  minus the output voltage swing to  $V_S$ .
- The minimum differential input signal multiplied by the gain plus  $V_{REF}$  is greater than the swing to GND (see the [Rail-to-Rail Output Swing](#) section).

During normal operation, these devices produce an output voltage that is the *gained-up* representation of the difference voltage from  $IN+$  to  $IN-$  plus the reference voltage at  $V_{REF}$ .

### 6.4.2 Unidirectional Mode

This device is capable of monitoring current flowing in one direction (unidirectional) or in both directions (bidirectional) depending on how the REF pin is configured. The most common case is unidirectional, where the output is set to ground when no current is flowing by connecting the REF pin to ground, as shown in [Figure 6-2](#). When the current flows from the bus supply to the load, the input signal across  $IN+$  to  $IN-$  increases, and causes the output voltage at the OUT pin to increase.

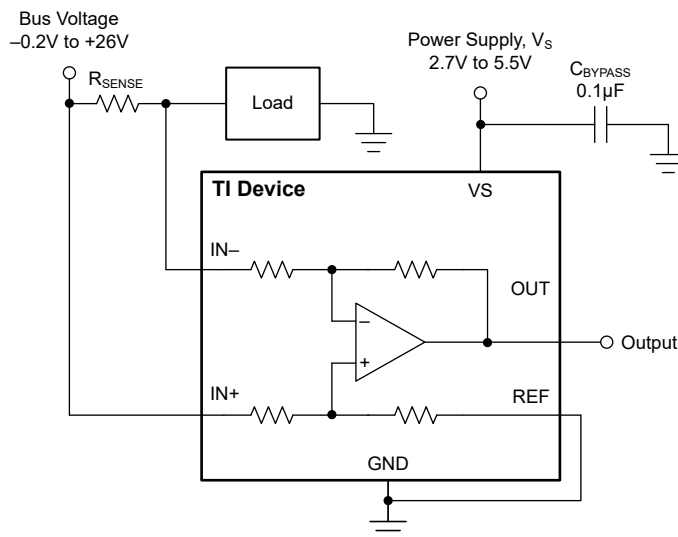

**Figure 6-2. Unidirectional Application**

The linear range of the output stage is limited by how close the output voltage can approach ground under zero input conditions. In unidirectional applications where measuring very low input currents is desirable, bias the REF pin to a convenient value above 50mV to get the output into the linear range of the device. To limit common-mode rejection errors, buffer the reference voltage connected to the REF pin.

A less-frequently used output biasing method is to connect the REF pin to the power-supply voltage,  $V_S$ . This method results in the output voltage saturating at 25mV less than the supply voltage when no differential input signal is present. This method is similar to the output saturated low condition with no input signal when the REF pin is connected to ground. The output voltage in this configuration only responds to negative currents that develop negative differential input voltage relative to the device  $IN-$  pin. Under these conditions, when the differential input signal increases negatively, the output voltage moves downward from the saturated supply voltage. The voltage applied to the REF pin must not exceed  $V_S$ .



### 6.4.3 Bidirectional Mode

The INA185-Q1 is a bidirectional current-sense amplifier capable of measuring currents through a resistive shunt in two directions. This bidirectional monitoring is common in applications that include charging and discharging operations where the current flowing through the resistor can change directions.

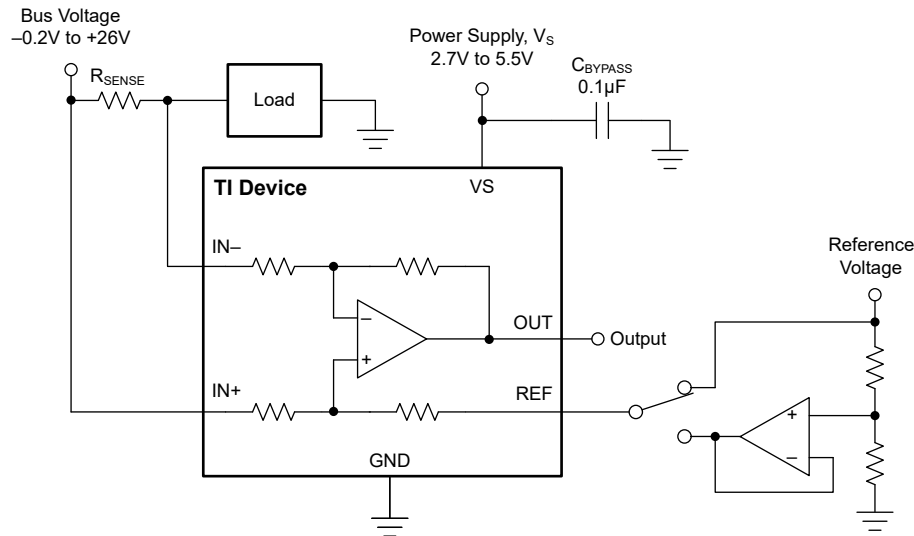

**Figure 6-3. Bidirectional Application**

The ability to measure this current flowing in both directions is enabled by applying a voltage to the REF pin, as shown in [Figure 6-3](#). The voltage applied to REF ( $V_{REF}$ ) sets the output state that corresponds to the zero-input level state. The output then responds by increasing above  $V_{REF}$  for positive differential signals (relative to the IN- pin) and responds by decreasing below  $V_{REF}$  for negative differential signals. This reference voltage applied to the REF pin can be set anywhere between 0V to  $V_S$ . For bidirectional applications,  $V_{REF}$  is typically set at mid-scale for equal signal range in both current directions. In some cases, however,  $V_{REF}$  is set at a voltage other than midscale when the bidirectional current and corresponding output signal do not need to be symmetrical.

### 6.4.4 Input Differential Overload

If the differential input voltage ( $V_{IN+} - V_{IN-}$ ) times gain plus the reference voltage exceeds the voltage swing specification, the INA185-Q1 drives the output as close as possible to the positive supply or ground, and does not provide accurate measurement of the differential input voltage. If this input overload occurs during normal circuit operation, then reduce the value of the shunt resistor or use a lower-gain version with the chosen sense resistor to avoid this mode of operation. If a differential overload occurs in a fault event, then the output of the INA185-Q1 returns to the expected value approximately 20µs after the fault condition is removed.

### 6.4.5 Shutdown Mode

Although the INA185-Q1 does not have a shutdown pin, the low power consumption of these devices allows the output of a logic gate or transistor switch to power the INA185-Q1. This gate or switch turns on and off the INA185-Q1 power-supply quiescent current.

However, in current shunt monitoring applications, the amount of current drained from the shunt circuit in shutdown conditions is also a concern. Evaluating this current drain involves considering the simplified schematic of the INA185-Q1 in shutdown mode, as shown in [Figure 6-4](#).

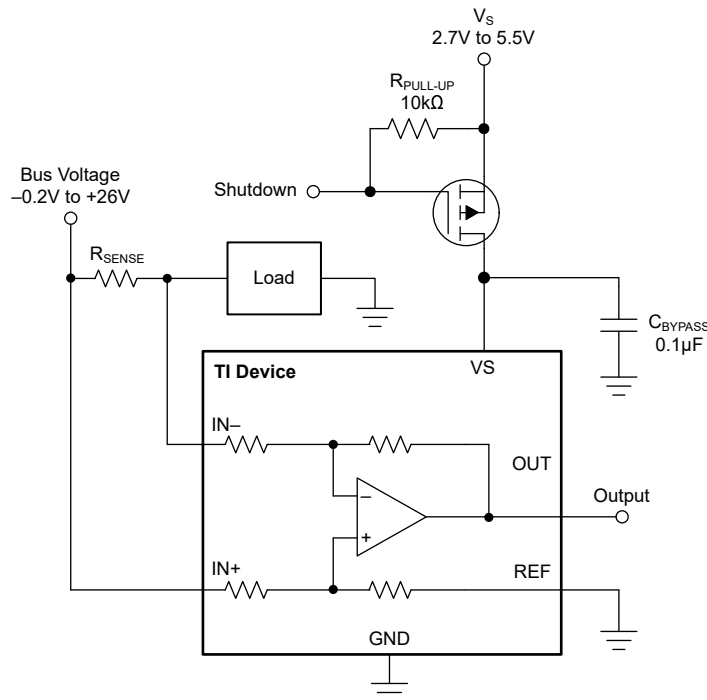

**Figure 6-4. Basic Circuit to Shut Down the INA185-Q1 With a Grounded Reference**

There is typically more than 500kΩ of impedance (from the combination of 500kΩ feedback and input gain set resistors) from each input of the INA185-Q1 to the OUT pin and to the REF pin. The amount of current flowing through these pins depends on the voltage at the connection. For example, if the REF pin is grounded, the calculation of the effect of the 500kΩ impedance from the shunt to ground is straightforward. However, if the reference is powered while the INA185-Q1 is in shutdown mode, the input current is determined by the 500kΩ impedance and the voltage difference between the positive input and the voltage applied to the REF pin.

Regarding the 500kΩ path to the output pin, the output stage of a disabled INA185-Q1 does constitute a good path to ground. Consequently, this current is directly proportional to a shunt common-mode voltage present across a 500kΩ resistor.

As long as the shunt common-mode voltage is greater than  $V_S$  when the device is powered up, there is an additional and well-matched 55μA typical current that flows in each of the inputs. If less than  $V_S$ , the common-mode input currents are negligible, and the only current effects are the result of the 500kΩ resistors.

## 7 Application and Implementation

### Note

Information in the following applications sections is not part of the TI component specification, and TI does not warrant its accuracy or completeness. TI's customers are responsible for determining suitability of components for their purposes, as well as validating and testing their design implementation to confirm system functionality.

### 7.1 Application Information

The INA185-Q1 amplifies the voltage developed across a current-sensing resistor as current flows through the resistor to the load or ground. The ability to drive the reference pin to adjust the functionality of the output signal offers multiple configurations, as discussed in previous sections.

#### 7.1.1 Basic Connections

Figure 7-1 shows the basic connections of the INA185-Q1. Connect the input pins (IN+ and IN-) to the shunt resistor as close as possible to minimize any resistance in series with the shunt resistor.

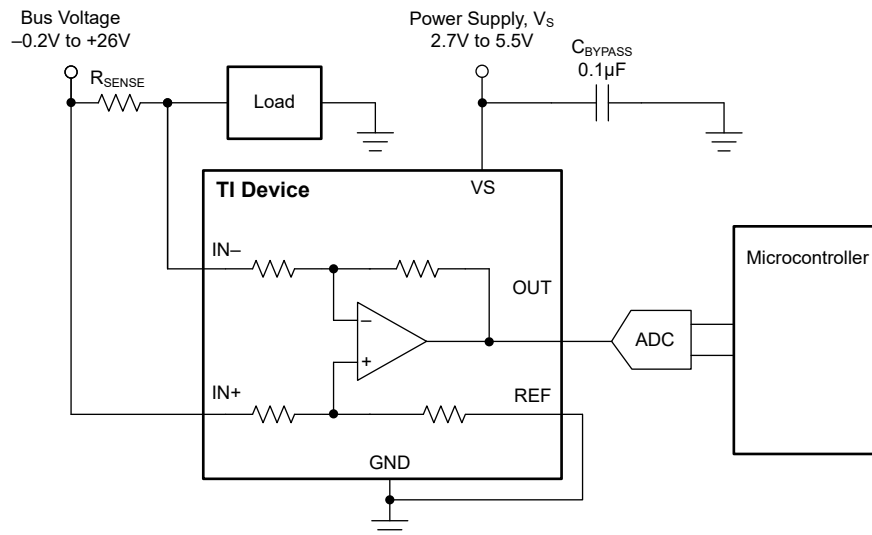

NOTE: To help eliminate ground offset errors between the device and the analog-to-digital converter (ADC), connect the REF pin to the ADC reference input and then to ground. For best performance, use an RC filter between the output of the INA185-Q1 and the ADC.

See the [Closed-Loop Analysis of Load-Induced Amplifier Stability Issues Using ZOUT](#) application note for more details.

**Figure 7-1. Basic Connections for the INA185-Q1**

A power-supply bypass capacitor of at least 0.1µF is required for proper operation. Applications with noisy or high-impedance power supplies can require additional decoupling capacitors to reject power-supply noise. Connect bypass capacitors close to the device pins.

### 7.1.2 R<sub>SENSE</sub> and Device Gain Selection

User can choose a current-sense resistor that is as large as possible to maximize the accuracy of the INA185-Q1. A large sense resistor maximizes the differential input signal for a given amount of current flow and reduces the error contribution of the offset voltage. However, there are practical limits as to how large the current-sense resistor can be in a given application. The INA185-Q1 has a typical input bias current of 75µA for each input when operated at a 12V common-mode voltage input. When large current-sense resistors are used, these bias currents cause increased offset error and reduced common-mode rejection. Therefore, using current-sense resistors larger than a few ohms is generally not recommended for applications that require current-monitoring accuracy. Another common restriction on the value of the current-sense resistor is the maximum allowable power dissipation that is budgeted for the resistor. Equation 2 gives the maximum value for the current sense resistor for a given power dissipation budget:

$$R_{\text{SENSE}} < \frac{PD_{\text{MAX}}}{I_{\text{MAX}}^2} \quad (2)$$

where:

- $PD_{\text{MAX}}$  is the maximum allowable power dissipation in  $R_{\text{SENSE}}$ .
- $I_{\text{MAX}}$  is the maximum current that flows through  $R_{\text{SENSE}}$ .

An additional limitation on the size of the current-sense resistor and device gain is due to the power-supply voltage,  $V_S$ , and device swing-to-rail limitations. To make sure that the current-sense signal is properly passed to the output, both positive and negative output swing limitations must be examined. Equation 3 provides the maximum values of  $R_{\text{SENSE}}$  and GAIN to keep the device from hitting the positive swing limitation.

$$I_{\text{MAX}} \times R_{\text{SENSE}} \times \text{GAIN} < V_{\text{SP}} - V_{\text{REF}} \quad (3)$$

where:

- $I_{\text{MAX}}$  is the maximum current that flows through  $R_{\text{SENSE}}$ .
- GAIN is the gain of the current sense-amplifier.
- $V_{\text{SP}}$  is the positive output swing specified in the data sheet.
- $V_{\text{REF}}$  is the externally applied voltage on the REF pin.

To avoid positive output swing limitations when selecting the value of  $R_{\text{SENSE}}$ , there is always a trade-off between the value of the sense resistor and the gain of the device to consider. If the sense resistor selected for the maximum power dissipation is too large, then selecting a lower-gain device to avoid positive swing limitations is possible.

The negative swing limitation places a limit on how small of a sense resistor can be used in a given application. Equation 4 provides the limit on the minimum size of the sense resistor.

$$I_{\text{MIN}} \times R_{\text{SENSE}} \times \text{GAIN} > V_{\text{SN}} - V_{\text{REF}} \quad (4)$$

where:

- $I_{\text{MIN}}$  is the minimum current that flows through  $R_{\text{SENSE}}$ .
- GAIN is the gain of the current sense amplifier.
- $V_{\text{SN}}$  is the negative output swing of the device (see [Rail-to-Rail Output Swing](#)).
- $V_{\text{REF}}$  is the externally applied voltage on the REF pin.

In addition to adjusting the offset and gain, the voltage applied to the REF pin can be slightly increased to avoid negative swing limitations.

### 7.1.3 Signal Filtering

Provided that the INA185-Q1 output is connected to a high-impedance input, the best location to filter is at the device output using a simple RC network from OUT to GND. Filtering at the output attenuates high-frequency disturbances in the common-mode voltage, differential input signal, and the INA185-Q1 power-supply voltage. If filtering at the output is not possible, or filtering of only the differential input signal is required, then apply a filter at the input pins of the device. Figure 7-2 provides an example of how a filter can be used on the input pins of the device.

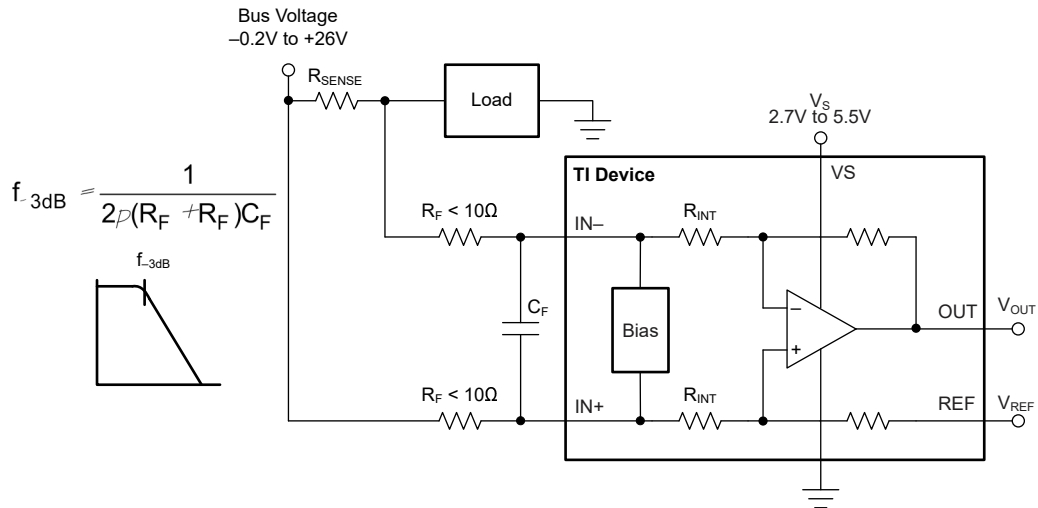

Figure 7-2. Filter at Input Pins

The addition of external series resistance creates an additional error in the measurement, therefore the value of these series resistors must be kept to 10Ω (or less, if possible) to reduce impact to accuracy. The internal bias network (Figure 7-2) present at the input pins creates a mismatch in input bias currents when a differential voltage is applied between the input pins. If additional external series filter resistors are added to the circuit, the mismatch in bias currents results in a mismatch of voltage drops across the filter resistors. This mismatch creates a differential error voltage that subtracts from the voltage developed across the shunt resistor. This error results in a voltage at the device input pins that is different than the voltage developed across the shunt resistor. Without the additional series resistance, the mismatch in input bias currents has little effect on device operation. Use Equation 5 to calculate the gain error factor, then use Equation 6 to calculate the amount of error these external filter resistors add to the measurement.

The amount of variance in the differential voltage present at the device input relative to the voltage developed at the shunt resistor is based both on the external series resistance ( $R_F$ ) value as well as the internal input resistor  $R_{INT}$ , as shown in Figure 7-2. The reduction of the shunt voltage reaching the device input pins appears as a gain error when comparing the output voltage relative to the voltage across the shunt resistor. A factor can be calculated to determine the amount of gain error that is introduced by the addition of external series resistance. Use Equation 5 to calculate the expected deviation from the shunt voltage to what is measured at the device input pins:

$$\text{Gain Error Factor} = \frac{1250 \times R_{INT}}{(1250 \times R_F) + (1250 \times R_{INT}) + (R_F \times R_{INT})} \quad (5)$$

where:

- $R_{INT}$  is the internal input resistor.
- $R_F$  is the external series resistance.

With the adjustment factor from [Equation 5](#), including the device internal input resistance, this factor varies with each gain version, as shown in [Table 7-1](#). Each individual device gain error factor is shown in [Table 7-2](#).

**Table 7-1. Input Resistance**

PRODUCT	GAIN	R <sub>INT</sub> (kΩ)
INA185A1	20	25
INA185A2	50	10
INA185A3	100	5
INA185A4	200	2.5

**Table 7-2. Device Gain Error Factor**

PRODUCT	SIMPLIFIED GAIN ERROR FACTOR
INA185A1	$\frac{25000}{(21 \times R_F) + 25000}$
INA185A2	$\frac{10000}{(9 \times R_F) + 10000}$
INA185A3	$\frac{1000}{R_F + 1000}$
INA185A4	$\frac{2500}{(3 \times R_F) + 2500}$

The gain error that can be expected from the addition of the external series resistors can then be calculated based on [Equation 6](#):

$$\text{Gain Error (\%)} = 100 - (100 \times \text{Gain Error Factor}) \tag{6}$$

For example, using an INA185A2 and the corresponding gain error equation from [Table 7-2](#), a series resistance of 10Ω results in a gain error factor of 0.991. The corresponding gain error is then calculated using [Equation 6](#), resulting in an additional gain error of approximately 0.89% solely because of the external 10Ω series resistors.

## 7.2 Typical Application

One application for the INA185-Q1 is to monitor bidirectional currents. Bidirectional currents are present in systems that have to monitor currents in both directions; common examples are monitoring the charging and discharging of batteries and bidirectional current monitoring in motor control. Figure 7-3 shows the device configuration for bidirectional current monitoring. Applying stable REF pin voltage closer to the middle of device supply voltage allows both positive- and negative-current monitoring, as shown in this configuration. Configure the INA185-Q1 to monitor unidirectional currents by grounding the REF pin.

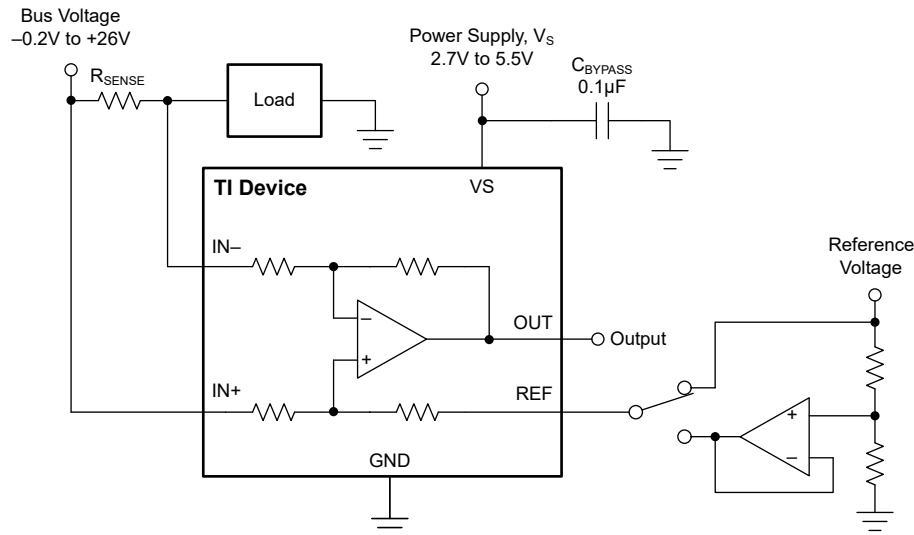

**Figure 7-3. Measuring Bidirectional Current**

### 7.2.1 Design Requirements

The design requirements for the circuit shown in Figure 7-3, are listed in Table 7-3.

**Table 7-3. Design Parameters**

DESIGN PARAMETER	EXAMPLE VALUE
Power-supply voltage, $V_S$	5V
Bus supply rail, $V_{CM}$	12V
$R_{SENSE}$ power loss	< 450mW
Maximum sense current, $I_{MAX}$	$\pm 20A$
Current sensing error	Less than 1% at maximum current, $T_J = 25^\circ C$
Small-signal bandwidth	> 100kHz

### 7.2.2 Detailed Design Procedure

The maximum value of the current sense resistor is calculated based on the maximum power loss requirement. By applying Equation 2, the maximum value of the current-sense resistor is 1.125m $\Omega$ . This is the maximum value for sense resistor  $R_{SENSE}$ ; therefore, set  $R_{SENSE}$  to 1m $\Omega$  as this value is the closest standard resistor value that meets the power-loss requirement.

The next step is to select the appropriate gain and reduce  $R_{SENSE}$ , if needed, to keep the output signal swing within the  $V_S$  range. The design requirements call for bidirectional current monitoring; therefore, a voltage between 0 and  $V_S$  must be applied to the REF pin. The bidirectional currents monitored are symmetric around 0 (that is,  $\pm 20A$ ); therefore, the ideal voltage to apply to  $V_{REF}$  is  $V_S / 2$  or 2.5V. If the positive current is greater than the negative current, using a lower voltage on  $V_{REF}$  has the benefit of maximizing the output swing for the given range of expected currents. Using Equation 3, and given that  $I_{MAX} = 20A$ ,  $R_{SENSE} = 1m\Omega$ , and  $V_{REF} = 2.5V$ , the maximum current-sense gain calculated to avoid the positive swing-to-rail limitations on the output is 122.5V/V. Likewise, using Equation 4 for the negative-swing limitation results in a maximum gain of 124.75V/V. Selecting

the gain-of-100 device maximizes the output range while staying within the output swing range. If the maximum calculated gains are slightly less than 100V/V, the value of the current-sense resistor can be reduced to keep the output from hitting the output-swing limitations.

To calculate the accuracy at peak current, the two factors that must be determined are the gain error and the offset error. The gain error of the INA185A3 is specified to be a maximum of 0.2%. The error due to the offset is constant, and is specified to be 130μV (maximum) for the conditions where  $V_{CM} = 12V$  and  $V_S = 5V$ . Using Equation 7, the percentage error contribution of the offset voltage is calculated to be 0.65%, with total offset error = 130μV,  $R_{SENSE} = 1m\Omega$ , and  $I_{SENSE} = 20A$ .

$$\text{Total Offset Error (\%)} = \frac{\text{Total Offset Error (V)}}{I_{SENSE} \times R_{SENSE}} \times 100\% \quad (7)$$

One method of calculating the total error is to add the gain error to the percentage contribution of the offset error. However, in this case, the gain error and the offset error do not have an influence or correlation to each other. A more statistically-accurate method of calculating the total error is to use the RSS sum of the errors, as shown in Equation 8:

$$\text{Total Error (\%)} = \sqrt{\text{Total Gain Error (\%)}^2 + \text{Total Offset Error (\%)}^2} \quad (8)$$

After applying Equation 8, the total current sense error at maximum current is calculated to be 0.68%, which is less than the design example requirement of 1%.

The INA185A3 (gain = 100V/V) also has a bandwidth of 150kHz that meets the small-signal bandwidth requirement of 100kHz. If higher bandwidth is required, lower-gain devices can be used at the expense of either reduced output voltage range or an increased value of  $R_{SENSE}$ .

### 7.2.3 Application Curve

Figure 7-4 shows an example output response of a bidirectional configuration. With the REF pin connected to a reference voltage (2.5V in this case), the output voltage is biased upwards by this reference level. The output rises above the reference voltage for positive differential input signals, and falls below the reference voltage for negative differential input signals.

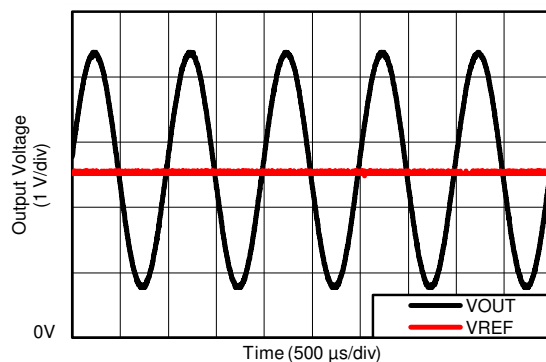

**Figure 7-4. Bidirectional Application Output Response**



## 7.3 Power Supply Recommendations

The input circuitry of the INA185-Q1 allows for accurate measurements beyond the power-supply voltage,  $V_S$ . For example,  $V_S$  can be 5V, whereas the bus supply voltage at IN+ and IN– can be as high as 26V. However, the output voltage range of the OUT pin is limited by the voltages on the VS pin. The INA185-Q1 also withstands the full differential input signal range up to 26V at the IN+ and IN– input pins, regardless of whether or not the device has power applied at the VS pin.

### 7.3.1 Common-Mode Transients Greater Than 26V

With a small amount of additional circuitry, the INA185-Q1 can be used in circuits that are subjected to transients higher than 26V, such as automotive applications. Use only Zener diodes or Zener-type transient absorbers (sometimes referred to as *transorbs*)—any other type of transient absorber has an unacceptable time delay. Start by adding a pair of resistors as a working impedance for the Zener diode. See [Figure 7-5](#). Keep these resistors as small as possible; most often, around 10Ω. Larger values can be used with an effect on gain that is discussed in the [Signal Filtering](#) section. This circuit limits only short-term transients, therefore many applications are satisfied with a 10Ω resistor along with conventional Zener diodes of the lowest acceptable power rating. This combination uses the least amount of board space. These diodes can be found in packages as small as SOT-523 or SOD-523.

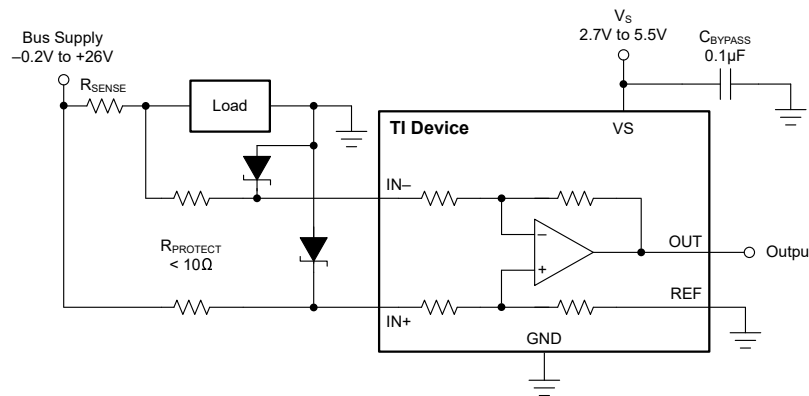

**Figure 7-5. Transient Protection Using Dual Zener Diodes**

In the event that low-power Zener diodes do not have sufficient transient absorption capability, a higher-power transorb must be used. The most package-efficient solution involves using a single transorb and back-to-back diodes between the device inputs, as shown in [Figure 7-6](#). The most space-efficient solutions are dual, series-connected diodes in a single SOT-523 or SOD-523 package. In either of the examples shown in [Figure 7-5](#) and [Figure 7-6](#), the total board area required by the INA185-Q1 with all protective components is less than that of an SO-8 package, and only slightly greater than that of an MSOP-8 package.

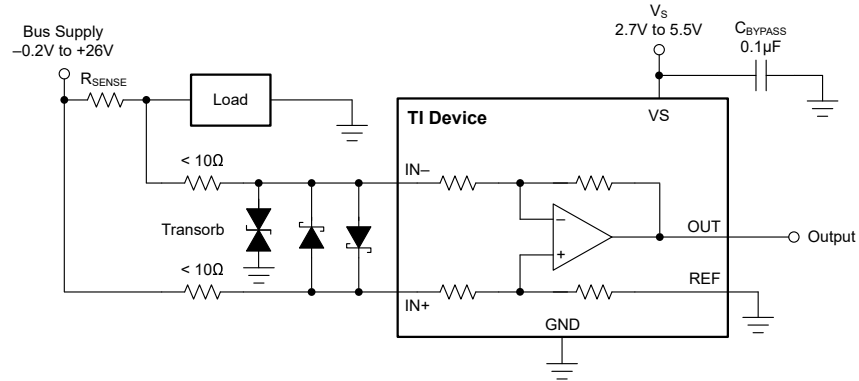

**Figure 7-6. Transient Protection Using a Single Transorb and Input Clamps**

For more information, see the [Current Shunt Monitor With Transient Robustness](#) reference design.

## 7.4 Layout

### 7.4.1 Layout Guidelines

- Connect the input pins to the sensing resistor using a Kelvin or 4-wire connection. This connection technique makes sure that only the current-sensing resistor impedance is detected between the input pins. Poor routing of the current-sensing resistor commonly results in additional resistance present between the input pins. Given the very-low ohmic value of the current resistor, any additional high-current carrying impedance can cause significant measurement errors.
- Place the power-supply bypass capacitor as close as possible to the device power supply and ground pins. The recommended value of this bypass capacitor is 0.1µF. Additional decoupling capacitance can be added to compensate for noisy or high-impedance power supplies.
- When routing the connections from the current sense resistor to the device, keep the trace lengths as close as possible to minimize any impedance mismatch.

### 7.4.2 Layout Example

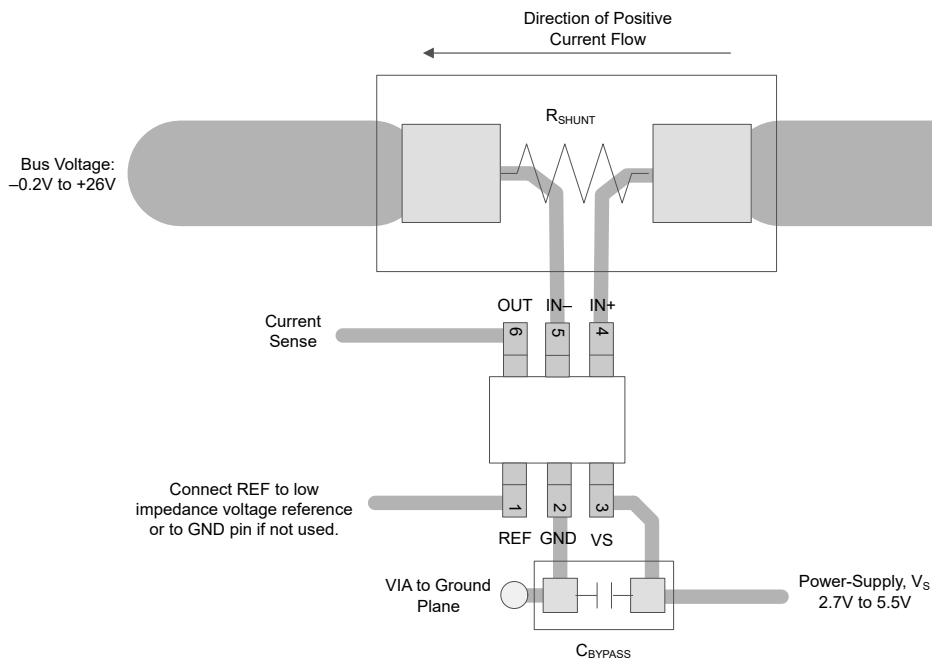

**Figure 7-7. SC70 Recommended Layout**

## 8 Device and Documentation Support

### 8.1 Device Support

#### 8.1.1 Development Support

Texas Instruments, [Current shunt monitor with transient robustness](#), reference design

### 8.2 Documentation Support

#### 8.2.1 Related Documentation

For related documentation see the following:

- Texas Instruments, [INA185EVM User's Guide](#) user's guide

### 8.3 Receiving Notification of Documentation Updates

To receive notification of documentation updates, navigate to the device product folder on [ti.com](#). Click on *Notifications* to register and receive a weekly digest of any product information that has changed. For change details, review the revision history included in any revised document.

### 8.4 Support Resources

[TI E2E™ support forums](#) are an engineer's go-to source for fast, verified answers and design help — straight from the experts. Search existing answers or ask your own question to get the quick design help you need.

Linked content is provided "AS IS" by the respective contributors. They do not constitute TI specifications and do not necessarily reflect TI's views; see TI's [Terms of Use](#).

### 8.5 Trademarks

TI E2E™ is a trademark of Texas Instruments.

All trademarks are the property of their respective owners.

### 8.6 Electrostatic Discharge Caution



This integrated circuit can be damaged by ESD. Texas Instruments recommends that all integrated circuits be handled with appropriate precautions. Failure to observe proper handling and installation procedures can cause damage.

ESD damage can range from subtle performance degradation to complete device failure. Precision integrated circuits may be more susceptible to damage because very small parametric changes could cause the device not to meet its published specifications.

### 8.7 Glossary

[TI Glossary](#) This glossary lists and explains terms, acronyms, and definitions.

## 9 Revision History

NOTE: Page numbers for previous revisions may differ from page numbers in the current version.

DATE	REVISION	NOTES
February 2024	*	Initial Release

## 10 Mechanical, Packaging, and Orderable Information

The following pages include mechanical, packaging, and orderable information. This information is the most current data available for the designated devices. This data is subject to change without notice and revision of this document. For browser-based versions of this data sheet, refer to the left-hand navigation.

**PACKAGING INFORMATION**

Orderable part number	Status (1)	Material type (2)	Package   Pins	Package qty   Carrier	RoHS (3)	Lead finish/ Ball material (4)	MSL rating/ Peak reflow (5)	Op temp (°C)	Part marking (6)
<a href="#">INA185A1QDCKRQ1</a>	Active	Production	SC70 (DCK)   6	3000   LARGE T&R	Yes	NIPDAU	Level-1-260C-UNLIM	-40 to 125	1Q8
INA185A1QDCKRQ1.B	Active	Production	SC70 (DCK)   6	3000   LARGE T&R	Yes	NIPDAU	Level-1-260C-UNLIM	-40 to 125	1Q8
<a href="#">INA185A2QDCKRQ1</a>	Active	Production	SC70 (DCK)   6	3000   LARGE T&R	Yes	NIPDAU	Level-1-260C-UNLIM	-40 to 125	1Q9
INA185A2QDCKRQ1.B	Active	Production	SC70 (DCK)   6	3000   LARGE T&R	Yes	NIPDAU	Level-1-260C-UNLIM	-40 to 125	1Q9
<a href="#">INA185A3QDCKRQ1</a>	Active	Production	SC70 (DCK)   6	3000   LARGE T&R	Yes	NIPDAU	Level-1-260C-UNLIM	-40 to 125	1QA
INA185A3QDCKRQ1.B	Active	Production	SC70 (DCK)   6	3000   LARGE T&R	Yes	NIPDAU	Level-1-260C-UNLIM	-40 to 125	1QA
<a href="#">INA185A4QDCKRQ1</a>	Active	Production	SC70 (DCK)   6	3000   LARGE T&R	Yes	NIPDAU	Level-1-260C-UNLIM	-40 to 125	1QB
INA185A4QDCKRQ1.B	Active	Production	SC70 (DCK)   6	3000   LARGE T&R	Yes	NIPDAU	Level-1-260C-UNLIM	-40 to 125	1QB

(1) **Status:** For more details on status, see our [product life cycle](#).

(2) **Material type:** When designated, preproduction parts are prototypes/experimental devices, and are not yet approved or released for full production. Testing and final process, including without limitation quality assurance, reliability performance testing, and/or process qualification, may not yet be complete, and this item is subject to further changes or possible discontinuation. If available for ordering, purchases will be subject to an additional waiver at checkout, and are intended for early internal evaluation purposes only. These items are sold without warranties of any kind.

(3) **RoHS values:** Yes, No, RoHS Exempt. See the [TI RoHS Statement](#) for additional information and value definition.

(4) **Lead finish/Ball material:** Parts may have multiple material finish options. Finish options are separated by a vertical ruled line. Lead finish/Ball material values may wrap to two lines if the finish value exceeds the maximum column width.

(5) **MSL rating/Peak reflow:** The moisture sensitivity level ratings and peak solder (reflow) temperatures. In the event that a part has multiple moisture sensitivity ratings, only the lowest level per JEDEC standards is shown. Refer to the shipping label for the actual reflow temperature that will be used to mount the part to the printed circuit board.

(6) **Part marking:** There may be an additional marking, which relates to the logo, the lot trace code information, or the environmental category of the part.

Multiple part markings will be inside parentheses. Only one part marking contained in parentheses and separated by a "~" will appear on a part. If a line is indented then it is a continuation of the previous line and the two combined represent the entire part marking for that device.

**Important Information and Disclaimer:** The information provided on this page represents TI's knowledge and belief as of the date that it is provided. TI bases its knowledge and belief on information provided by third parties, and makes no representation or warranty as to the accuracy of such information. Efforts are underway to better integrate information from third parties. TI has taken and continues to take reasonable steps to provide representative and accurate information but may not have conducted destructive testing or chemical analysis on incoming materials and chemicals. TI and TI suppliers consider certain information to be proprietary, and thus CAS numbers and other limited information may not be available for release.

In no event shall TI's liability arising out of such information exceed the total purchase price of the TI part(s) at issue in this document sold by TI to Customer on an annual basis.

**OTHER QUALIFIED VERSIONS OF INA185-Q1 :**

- Catalog : [INA185](#)

NOTE: Qualified Version Definitions:

- Catalog - TI's standard catalog product

**TAPE AND REEL INFORMATION**

**QUADRANT ASSIGNMENTS FOR PIN 1 ORIENTATION IN TAPE**

\*All dimensions are nominal

Device	Package Type	Package Drawing	Pins	SPQ	Reel Diameter (mm)	Reel Width W1 (mm)	A0 (mm)	B0 (mm)	K0 (mm)	P1 (mm)	W (mm)	Pin1 Quadrant
INA185A1QDCKRQ1	SC70	DCK	6	3000	178.0	9.0	2.4	2.5	1.2	4.0	8.0	Q3
INA185A2QDCKRQ1	SC70	DCK	6	3000	178.0	9.0	2.4	2.5	1.2	4.0	8.0	Q3
INA185A3QDCKRQ1	SC70	DCK	6	3000	178.0	9.0	2.4	2.5	1.2	4.0	8.0	Q3
INA185A4QDCKRQ1	SC70	DCK	6	3000	178.0	9.0	2.4	2.5	1.2	4.0	8.0	Q3

## TAPE AND REEL BOX DIMENSIONS



\*All dimensions are nominal

Device	Package Type	Package Drawing	Pins	SPQ	Length (mm)	Width (mm)	Height (mm)
INA185A1QDCKRQ1	SC70	DCK	6	3000	180.0	180.0	18.0
INA185A2QDCKRQ1	SC70	DCK	6	3000	180.0	180.0	18.0
INA185A3QDCKRQ1	SC70	DCK	6	3000	180.0	180.0	18.0
INA185A4QDCKRQ1	SC70	DCK	6	3000	180.0	180.0	18.0

# DCK0006A



# PACKAGE OUTLINE

SOT - 1.1 max height

SMALL OUTLINE TRANSISTOR

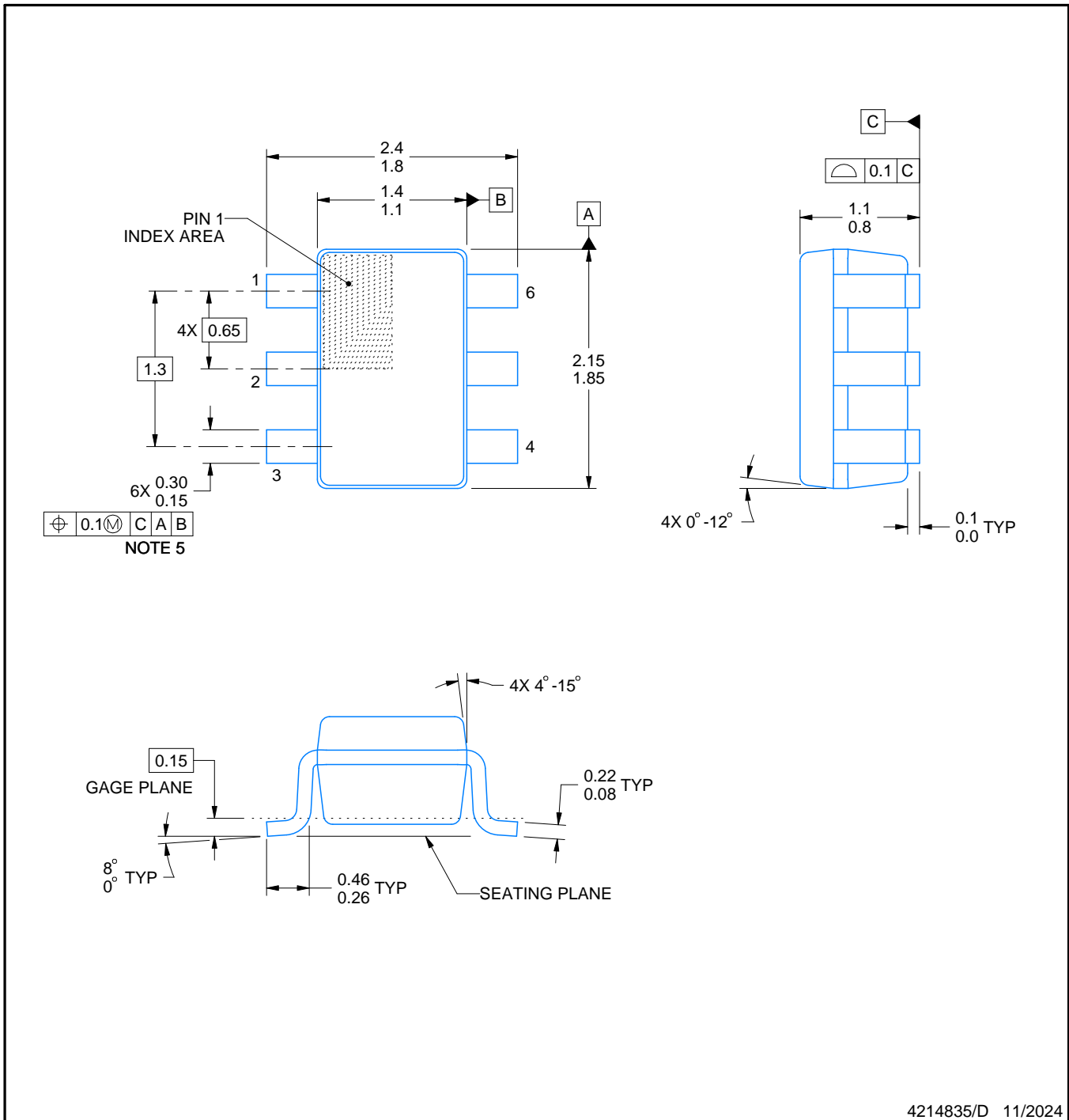

4214835/D 11/2024

## NOTES:

1. All linear dimensions are in millimeters. Any dimensions in parenthesis are for reference only. Dimensioning and tolerancing per ASME Y14.5M.
2. This drawing is subject to change without notice.
3. Body dimensions do not include mold flash or protrusion. Mold flash and protrusion shall not exceed 0.15 per side.
4. Falls within JEDEC MO-203 variation AB.



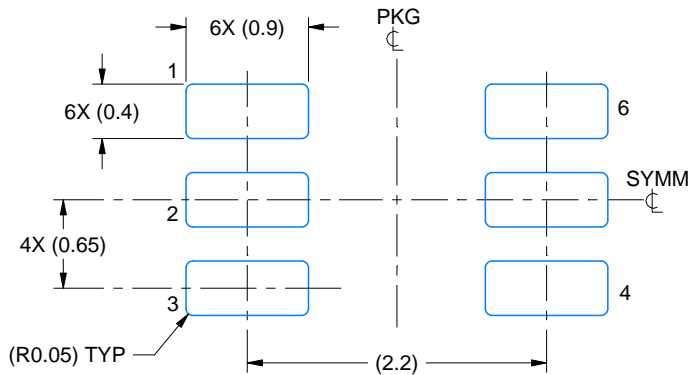

LAND PATTERN EXAMPLE  
EXPOSED METAL SHOWN  
SCALE:18X

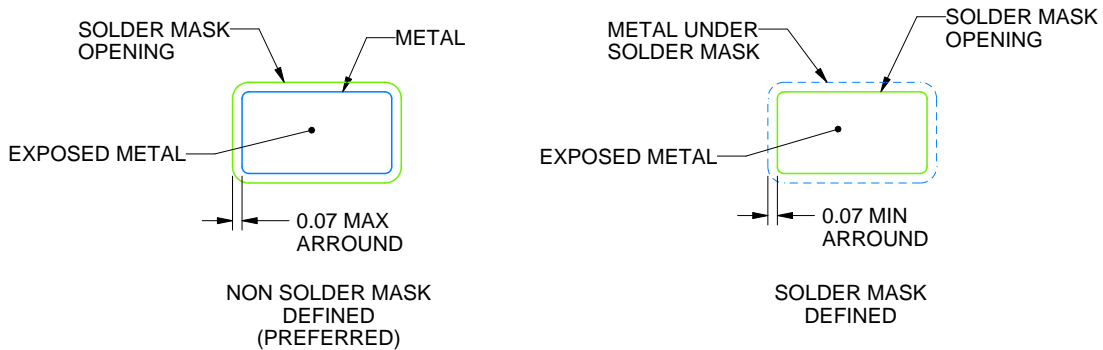

SOLDER MASK DETAILS

4214835/D 11/2024

NOTES: (continued)

5. Publication IPC-7351 may have alternate designs.
6. Solder mask tolerances between and around signal pads can vary based on board fabrication site.

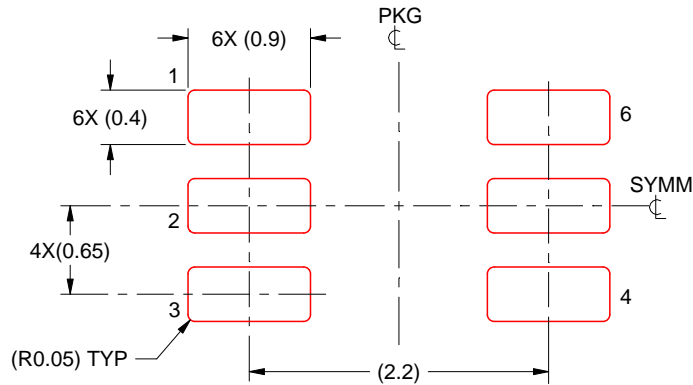

SOLDER PASTE EXAMPLE  
BASED ON 0.125 THICK STENCIL  
SCALE:18X

4214835/D 11/2024

NOTES: (continued)

7. Laser cutting apertures with trapezoidal walls and rounded corners may offer better paste release. IPC-7525 may have alternate design recommendations.
8. Board assembly site may have different recommendations for stencil design.

## IMPORTANT NOTICE AND DISCLAIMER

TI PROVIDES TECHNICAL AND RELIABILITY DATA (INCLUDING DATASHEETS), DESIGN RESOURCES (INCLUDING REFERENCE DESIGNS), APPLICATION OR OTHER DESIGN ADVICE, WEB TOOLS, SAFETY INFORMATION, AND OTHER RESOURCES "AS IS" AND WITH ALL FAULTS, AND DISCLAIMS ALL WARRANTIES, EXPRESS AND IMPLIED, INCLUDING WITHOUT LIMITATION ANY IMPLIED WARRANTIES OF MERCHANTABILITY, FITNESS FOR A PARTICULAR PURPOSE OR NON-INFRINGEMENT OF THIRD PARTY INTELLECTUAL PROPERTY RIGHTS.

These resources are intended for skilled developers designing with TI products. You are solely responsible for (1) selecting the appropriate TI products for your application, (2) designing, validating and testing your application, and (3) ensuring your application meets applicable standards, and any other safety, security, regulatory or other requirements.

These resources are subject to change without notice. TI grants you permission to use these resources only for development of an application that uses the TI products described in the resource. Other reproduction and display of these resources is prohibited. No license is granted to any other TI intellectual property right or to any third party intellectual property right. TI disclaims responsibility for, and you fully indemnify TI and its representatives against any claims, damages, costs, losses, and liabilities arising out of your use of these resources.

TI's products are provided subject to [TI's Terms of Sale](#), [TI's General Quality Guidelines](#), or other applicable terms available either on [ti.com](#) or provided in conjunction with such TI products. TI's provision of these resources does not expand or otherwise alter TI's applicable warranties or warranty disclaimers for TI products. Unless TI explicitly designates a product as custom or customer-specified, TI products are standard, catalog, general purpose devices.

TI objects to and rejects any additional or different terms you may propose.

Copyright © 2025, Texas Instruments Incorporated

Last updated 10/2025