

LM66100 5.5-V, 1.5-A 79-mΩ, Low IQ Ideal Diode With Input Polarity Protection

1 Features

- Wide operating voltage range: 1.5 V – 5.5 V
- Reverse voltage standoff on VIN: –6-V absolute maximum
- Maximum continuous current (I_{MAX}): 1.5 A
- On-Resistance (R_{ON}):
 - 5-V $V_{IN} = 79\text{-m}\Omega$ (typical)
 - 3.6-V $V_{IN} = 91\text{-m}\Omega$ (typical)
 - 1.8-V $V_{IN} = 141\text{-m}\Omega$ (typical)
- Comparator chip enable (\overline{CE})
- Channel status indication (ST)
- Low current consumption:
 - 3.6-V V_{IN} Shutdown current ($I_{SD,VIN}$): 120-nA (typical)
 - 3.6-V V_{IN} Quiescent current ($I_{Q,VIN}$): 150-nA (typical)

2 Applications

- Smart meters
- Building automation
- GPS and tracking
- Primary and backup batteries

3 Description

The LM66100 is a Single-Input, Single-Output (SISO) integrated ideal diode that is well suited for a variety of applications. The device contains a P-channel MOSFET that can operate over an input voltage range of 1.5 V to 5.5 V and can support a maximum continuous current of 1.5 A.

The chip enable works by comparing the \overline{CE} pin voltage to the input voltage. When the \overline{CE} pin voltage is higher than V_{IN} , the device is disabled and the MOSFET is off. When the \overline{CE} pin voltage is lower, the MOSFET is on. The LM66100 also comes with reverse polarity protection (RPP) that can protect the device from a miswired input, such as a reversed battery.

Two LM66100 devices can be used in an ORing configuration similar to a dual diode ORing implementation. In this configuration, the devices pass the highest input voltage to the output while blocking reverse current flow into the input supplies. These devices can compare input and output voltages to make sure that reverse current is blocked through an internal voltage comparator.

The LM66100 is available in a standard SC-70 package characterized for operation over a junction temperature range of -40°C to 125°C .

Device Information⁽¹⁾

PART NUMBER	PACKAGE	BODY SIZE (NOM)
LM66100	SC-70 (6)	2.1 mm x 2.0 mm

(1) For all available packages, see the orderable addendum at the end of the data sheet.

Typical Application

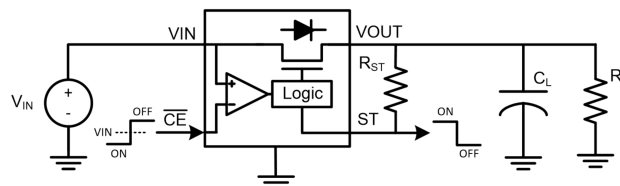

Table of Contents

1 Features	1	8.3 Feature Description.....	9
2 Applications	1	8.4 Device Functional Modes.....	10
3 Description	1	9 Application and Implementation	10
4 Revision History	2	9.1 Application Information.....	10
5 Pin Configuration and Functions	3	9.2 Typical Applications	10
6 Specifications	4	10 Power Supply Recommendations	13
6.1 Absolute Maximum Ratings	4	11 Layout	14
6.2 ESD Ratings.....	4	11.1 Layout Guidelines	14
6.3 Recommended Operating Conditions.....	4	11.2 Layout Example	14
6.4 Thermal Information	4	12 Device and Documentation Support	15
6.5 Electrical Characteristics.....	5	12.1 Receiving Notification of Documentation Updates	15
6.6 Switching Characteristics	5	12.2 Community Resources.....	15
6.7 Typical Characteristics	6	12.3 Trademarks	15
7 Parameter Measurement Information	7	12.4 Electrostatic Discharge Caution.....	15
8 Detailed Description	8	12.5 Glossary	15
8.1 Overview	8	13 Mechanical, Packaging, and Orderable Information	15
8.2 Functional Block Diagram	8		

4 Revision History

Changes from Original (March 2019) to Revision A

Page

• Changed from Advance Information to Production Data	1
---	---

5 Pin Configuration and Functions

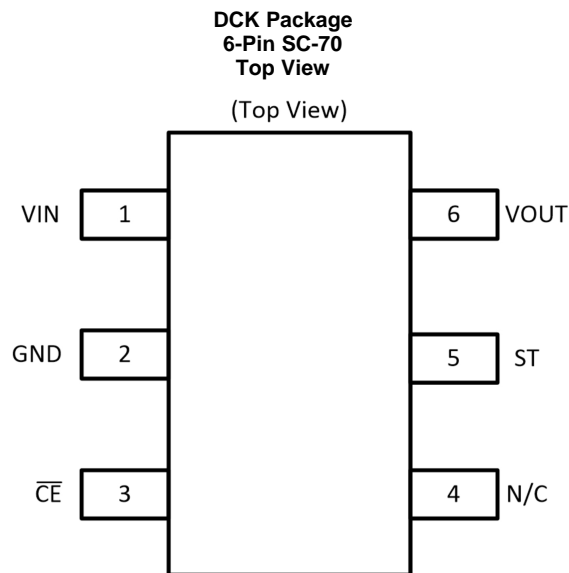

Pin Functions

PIN		I/O	DESCRIPTION
NO.	NAME		
1	VIN	I	Device input
2	GND	-	Device ground
3	\overline{CE}	I	Active-low chip enable. Can be connected to VOUT for reverse current protection. Do not leave floating.
4	N/C	-	Not internally connected, can be tied to GND or left floating.
5	ST	O	Active-low open-drain output, pulled low when the chip is disabled. Hi-Z when the chip is enabled. Connect to GND if not required.
6	VOUT	O	Device output

6 Specifications

6.1 Absolute Maximum Ratings

 over operating free-air temperature range (unless otherwise noted) ⁽¹⁾

		MIN	MAX	UNIT
V _{IN}	Maximum Input Voltage Range	-6	6	V
V _{OUT}	Maximum Output Voltage Range	-0.3	6	V
V _{CE}	Maximum $\overline{\text{CE}}$ Pin Voltage	-0.3	6	V
V _{ST}	Maximum ST Pin Voltage	-0.3	6	V
I _{SW, MAX}	Maximum Continuous Switch Current		1.5	A
I _{SW, PLS}	Maximum Pulsed Switch Current (≤ 120 ms, 2% Duty Cycle)		2.5	A
I _{D, PLS}	Maximum Pulsed Body Diode Current (≤ 0.1 ms, 0.2% Duty Cycle)		2.5	A
I _{CE}	Maximum $\overline{\text{CE}}$ Pin Current	-1		mA
I _{ST}	Maximum ST Pin Current	-1		mA
T _J	Junction temperature	-40	125	°C
T _{STG}	Storage temperature	-65	150	°C
T _{LEAD}	Maximum Lead Temperature (10 s soldering time)		300	°C

(1) Stresses beyond those listed under *Absolute Maximum Rating* may cause permanent damage to the device. These are stress ratings only, which do not imply functional operation of the device at these or any other conditions beyond those indicated under *Recommended Operating Condition*. Exposure to absolute-maximum-rated conditions for extended periods may affect device reliability.

6.2 ESD Ratings

			VALUE	UNIT
V _(ESD)	Electrostatic discharge	Human body model (HBM), per ANSI/ESDA/JEDEC JS-001, allpins ⁽¹⁾	±2000	V
		Charged device model (CDM), per JEDEC specification JESD22-C101, all pins ⁽²⁾	±500	

(1) JEDEC document JEP155 states that 500-V HBM allows safe manufacturing with a standard ESD control process.

(2) JEDEC document JEP157 states that 250-V CDM allows safe manufacturing with a standard ESD control process. Manufacturing with less is possible with the necessary precautions. Pins listed may actually have higher performance.

6.3 Recommended Operating Conditions

over operating free-air temperature range (unless otherwise noted)

		MIN	TYP	MAX	UNIT
V _{IN}	Input Voltage Range	1.5		5.5	V
V _{OUT}	Output Voltage Range	1		5.5	V
V _{CE}	$\overline{\text{CE}}$ Pin Voltage Range	0		5.5	V
V _{ST}	ST Pin Voltage Range	0		5.5	V

6.4 Thermal Information

THERMAL METRIC ⁽¹⁾		LM66100	UNIT
		DCK (SC-70)	
		6 PINS	
R _{θJA}	Junction-to-ambient thermal resistance	192	°C/W
R _{θJC(top)}	Junction-to-case (top) thermal resistance	124	°C/W
R _{θJB}	Junction-to-board thermal resistance	52	°C/W
Ψ _{JT}	Junction-to-top characterization parameter	34	°C/W
Ψ _{JB}	Junction-to-board characterization parameter	52	°C/W

(1) For more information about traditional and new thermal metrics, see the [Semiconductor and IC Package Thermal Metrics](#) application report.

6.5 Electrical Characteristics

Typical values are at 25°C with an input voltage of 3.6V (unless otherwise noted)

PARAMETER		TEST CONDITIONS		MIN	TYP	MAX	UNIT	
Input Supply (VIN)								
$I_{SD,VIN}$	VIN Shutdown Current	VOUT = VIN VCE > VIN + 80mV IOUT = 0 A (VOUT = open)	25°C	0.12	0.3		μA	
			-40°C to 105°C			0.3	μA	
$I_{Q,VIN}$	VIN Quiescent Current	VOUT = VIN VCE < VIN - 250mV IOUT = 0 A (VOUT = open)	25°C	0.15	0.3		μA	
			-40°C to 105°C			0.3	μA	
$I_{OUT, OFF}$	OUT to IN Leakage Current (Current out of VIN)	VOUT - VIN ≤ 5.5 V VCE > VIN + 80mV	25°C	0.2	0.5		μA	
			-40°C to 85°C			2.7	μA	
			-40°C to 105°C			8	μA	
		VOUT - VIN ≤ 4.5 V VCE > VIN + 80mV	-40°C to 85°C			1.7	μA	
			-40°C to 105°C			5.1	μA	
			-40°C to 85°C			0.7	μA	
-40°C to 105°C			2.1	μA				
ON-Resistance (RON)								
R_{ON}	ON-State Resistance	IOUT = -200 mA	VIN = 5 V	25°C	79	95	mΩ	
				-40°C to 85°C				110
				-40°C to 125°C				120
R_{ON}	ON-State Resistance	IOUT = -200 mA	VIN = 3.6 V	25°C	91	110	mΩ	
				-40°C to 85°C				125
				-40°C to 125°C				140
R_{ON}	ON-State Resistance	IOUT = -200 mA	VIN = 1.8 V	25°C	141	180	mΩ	
				-40°C to 85°C				210
				-40°C to 125°C				230
Comparator Chip Enable (CE)								
V_{ON}	Turn ON Threshold	VCE - VIN	-40°C to 125°C	-250	-150	-80	mV	
V_{OFF}	Turn OFF Threshold	VCE - VIN	-40°C to 125°C	0	35	80	mV	
I_{CE}	CE Pin Leakage Current	VCE < VIN - 250mV	-40°C to 125°C	0	160	300	nA	
I_{CE}	CE Pin Leakage Current	VCE > VIN + 80mV	-40°C to 125°C	0	400	610	nA	
Reverse Current Blocking (RCB) and Body Diode Characteristics								
I_{RCB}	Reverse Activation Current	VCE = VOUT	-40°C to 125°C	0.5	1		A	
V_{FWD}	Body Diode Forward Voltage	IOUT = 10 mA VCE > VIN + 80mV	-40°C to 125°C	0.1	0.5	1.1	V	
Status Indication (ST)								
$V_{OL, ST}$	Output Low Voltage	IST = 1 mA	-40°C to 125°C			0.1	V	
t_{ST}	Status Delay Time	VCE transitions from low to high	-40°C to 125°C		1		μs	
I_{ST}	ST Pin Leakage Current	VCE < VIN - 250mV	-40°C to 125°C	-20		20	nA	

6.6 Switching Characteristics

Unless otherwise noted, the typical characteristics in the following table applies over the entire recommended operating voltage at an ambient temperature of 25°C and a load of $C_L = 100$ nF and $R_L = 1$ kΩ

PARAMETER		TEST CONDITIONS		MIN	TYP	MAX	UNIT
t_{ON}	Turn ON Time	VIN = 1.8 V			90		μs
		VIN = 3.6 V			40		μs
		VIN = 5 V			27		μs
t_{OFF}	Turn OFF Time	VIN = 1.8 V			2		μs
		VIN = 3.6 V			2		μs
		VIN = 5 V			2		μs

Switching Characteristics (continued)

Unless otherwise noted, the typical characteristics in the following table applies over the entire recommended operating voltage at an ambient temperature of 25°C and a load of $C_L = 100$ nF and $R_L = 1$ k Ω

PARAMETER		TEST CONDITIONS	MIN	TYP	MAX	UNIT
t_{FALL}	Output Fall Time	VIN = 1.8 V		20		μ s
		VIN = 3.6 V		10		μ s
		VIN = 5 V		7.5		μ s

6.7 Typical Characteristics

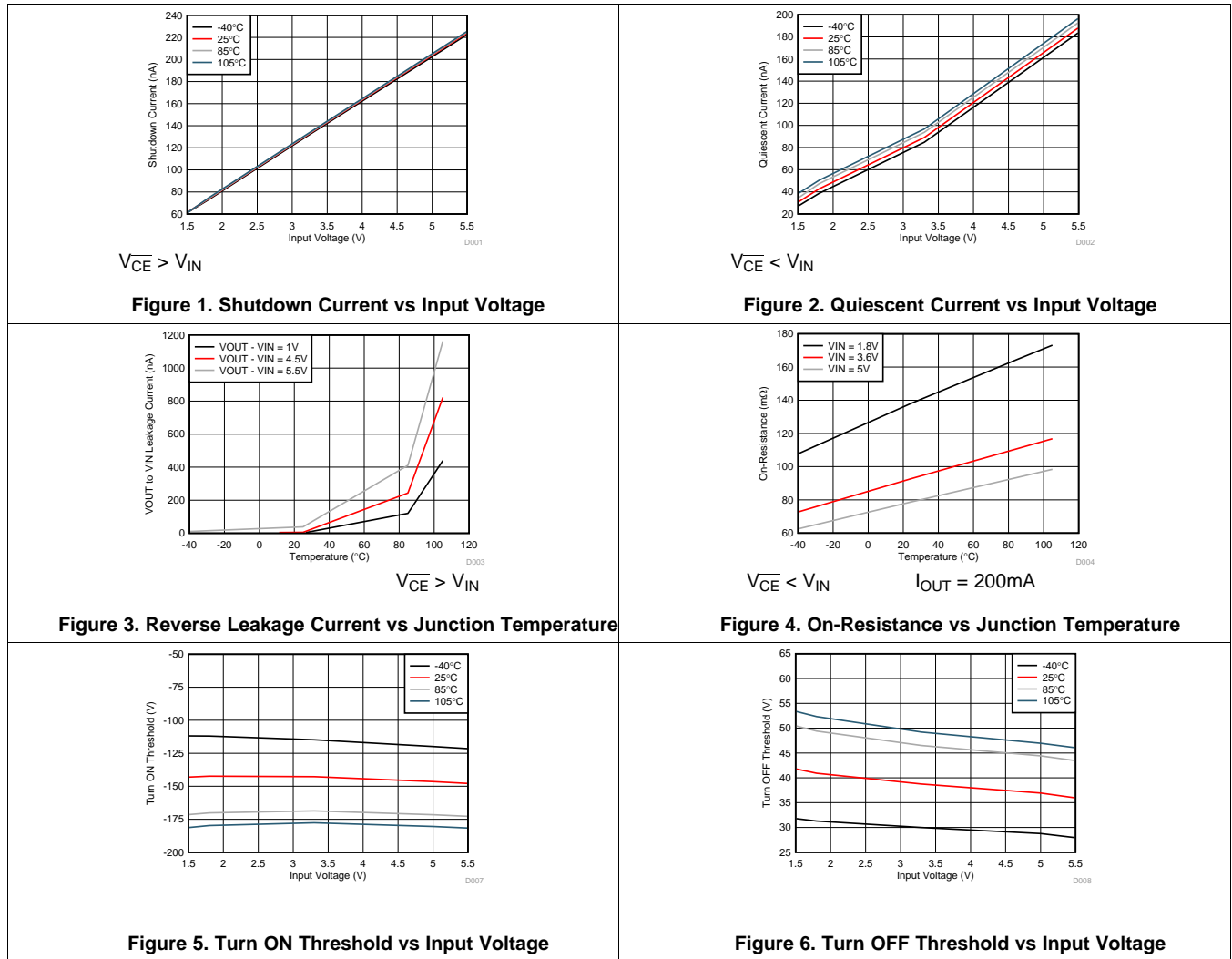

Typical Characteristics (continued)

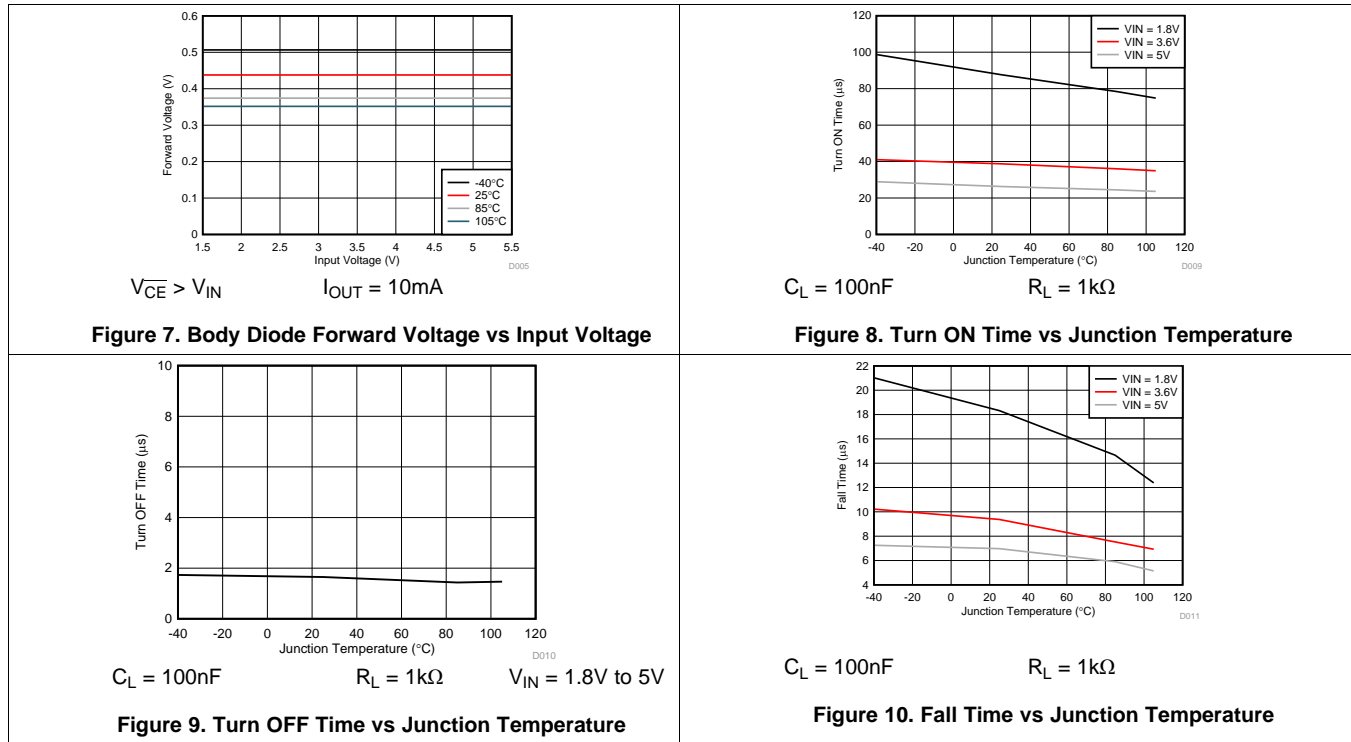

7 Parameter Measurement Information

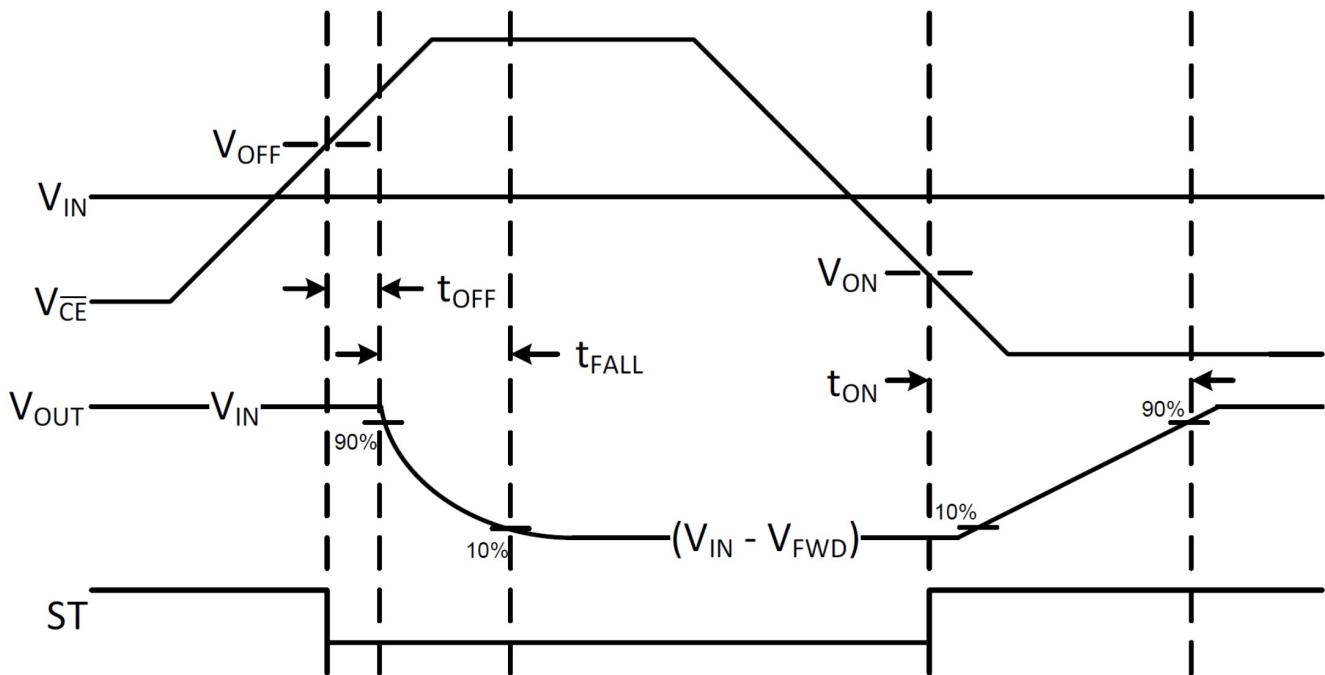

Figure 11. Timing Diagram

8 Detailed Description

8.1 Overview

The LM66100 is a Single-Input, Single-Output (SISO) integrated ideal diode that is well suited for a variety of applications. The device contains a P-channel MOSFET that can operate over an input voltage range of 1.5 V to 5.5 V and can support a maximum continuous current of 1.5 A.

The chip enable works by comparing the \overline{CE} pin voltage to the input voltage. When the \overline{CE} pin voltage is higher than V_{IN} by 80 mV, the device is disabled and the MOSFET is off. When the \overline{CE} pin voltage is lower than V_{IN} by 250 mV, the MOSFET is on. The LM66100 also comes with reverse polarity protection (RPP) that can protect the device from a miswired input, such as a reversed battery.

8.2 Functional Block Diagram

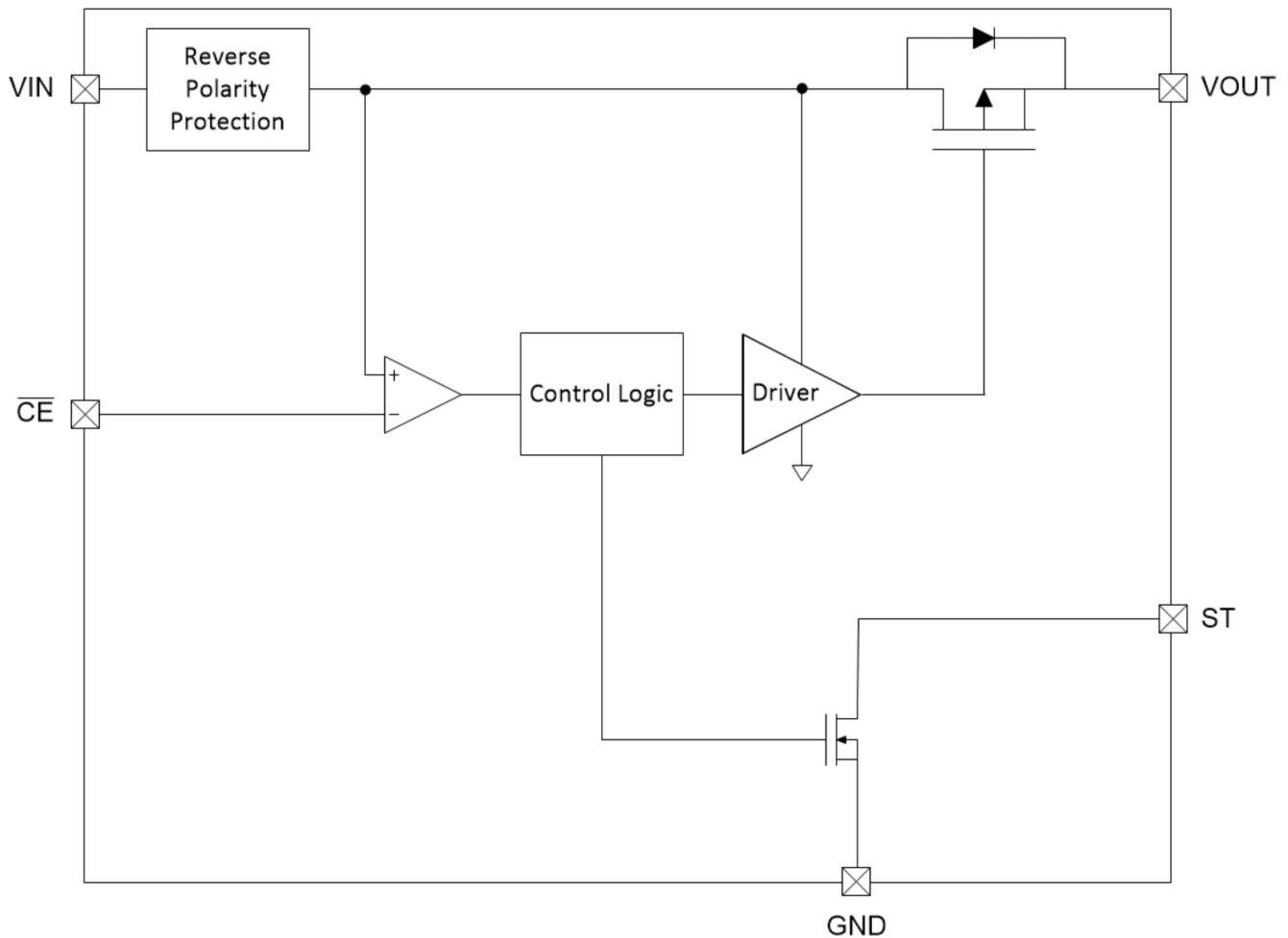

8.3 Feature Description

8.3.1 Reverse Polarity Protection (RPP)

In the event a negative input voltage is applied, the ideal diode will stay off and prevent current flow to protect the system load. For a stand-alone, always on application, \overline{CE} can be tied to GND so it will not go negative with respect to GND see Figure 12.

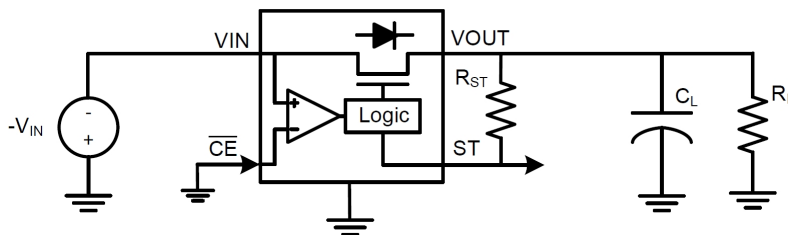

Figure 12. RPP Protection Circuit

8.3.2 Always-ON Reverse Current Blocking (RCB)

By connecting the \overline{CE} pin to VOUT, this allows the comparator to detect reverse current flow through the switch. If the output is forced above the selected input by V_{OFF} , the channel will switch off to stop the reverse current I_{RCB} within t_{OFF} . Once the output falls to below V_{IN} by V_{ON} , the device will turn back on.

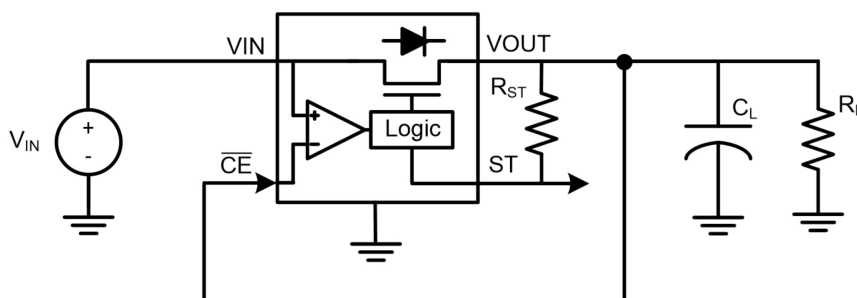

Figure 13. RCB Circuit

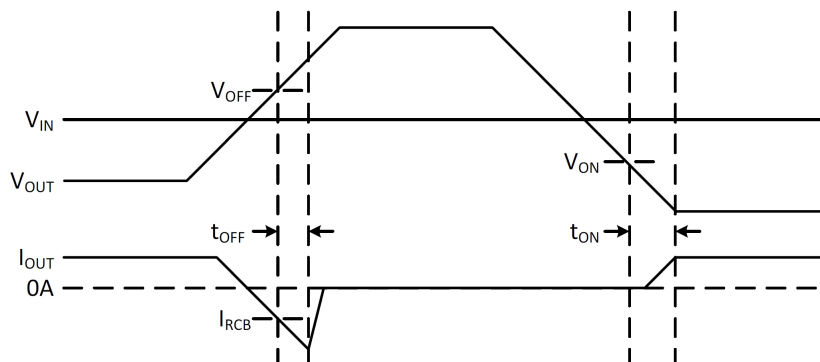

Figure 14. RCB Waveforms

8.4 Device Functional Modes

Table 1 summarizes the Device Functional Modes:

Table 1. Device Functional Modes

State	IN-to-OUT	Power Dissipation	ST State
OFF	Diode	$I_{OUT} \times V_{FWD}$	L
ON	Switch	$I_{OUT}^2 \times R_{ON}$	H

9 Application and Implementation

NOTE

Information in the following applications sections is not part of the TI component specification, and TI does not warrant its accuracy or completeness. TI's customers are responsible for determining suitability of components for their purposes. Customers should validate and test their design implementation to confirm system functionality.

9.1 Application Information

The LM66100 Ideal Diode can be used in a variety of stand-alone and multi-channel applications.

9.2 Typical Applications

9.2.1 Dual Ideal Diode ORing

Two LM66100 Ideal Diodes can be used together for ORing between two power supplies.

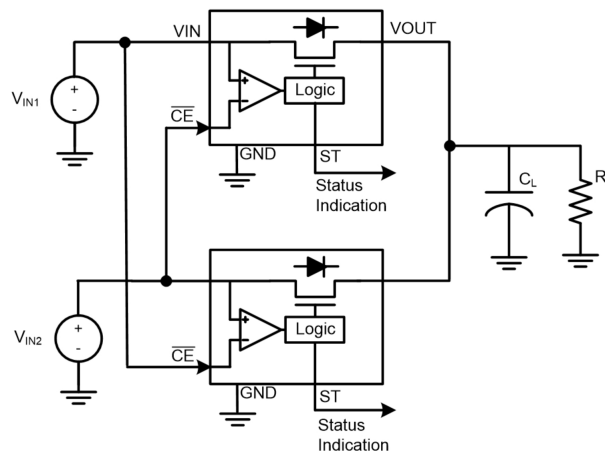

Figure 15. Dual Ideal Diode ORing

9.2.1.1 Design Requirements

Design a circuit that allows the highest input voltage to power a downstream system while providing reverse current protection.

9.2.1.2 Detailed Design Procedure

This circuit ties the \overline{CE} of each device to the opposite power source. In this configuration, the highest supply will always be selected using a make-before-break logic. This prevents any reverse current flow between the supplies and avoids the need of a dedicated reverse current blocking comparator. For ORing applications that need RPP, it is recommended to use a series resistor ($R_{\overline{CE}}$) to limit the current into the \overline{CE} pin during a negative voltage event.

Typical Applications (continued)

9.2.1.3 Application Curves

The below scope shot shows the output voltage (VOUT) being initially powered by VIN1. When VIN2 is applied, it powers VOUT because it is a higher voltage. When VIN2 is removed, VOUT is once again powered by VIN1.

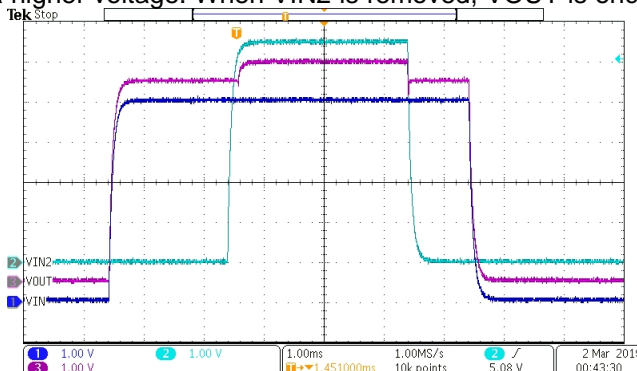

Figure 16. Dual Ideal Diode ORing Behavior

9.2.2 Dual Ideal Diode ORing for Continuous Output Power

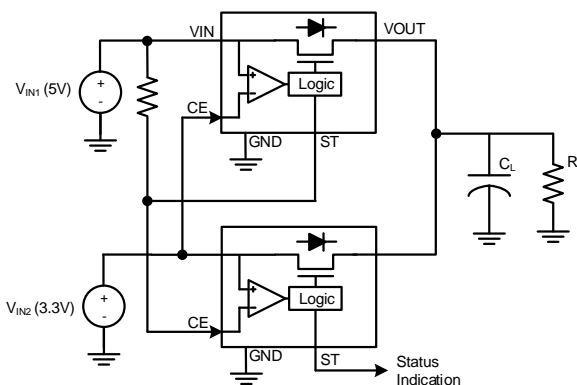

Figure 17. Dual Ideal Diode ORing for Continuous Output Power

9.2.2.1 Design Requirements

The shortcoming of the previous implementation happens when both input voltages are the same for a long period of time, then both devices will completely turn off, powering down the output load. To avoid this case, the status output from the priority supply and a pull up resistor can be used causing both devices to switchover at the same time. For ORing applications that need RPP, it is recommended to use a series resistor (R_{CE}) to limit the current into the CE pin during a negative voltage event.

Typical Applications (continued)

9.2.2.2 Application Curves

The figures below show the switchover performance between VIN1 and VIN2.

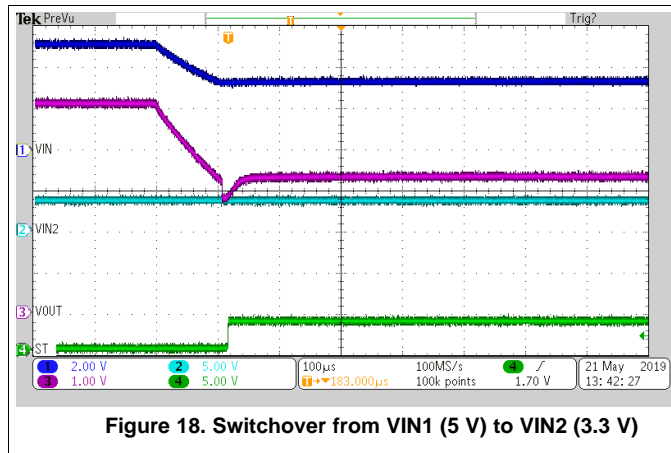

Figure 18. Switchover from VIN1 (5 V) to VIN2 (3.3 V)

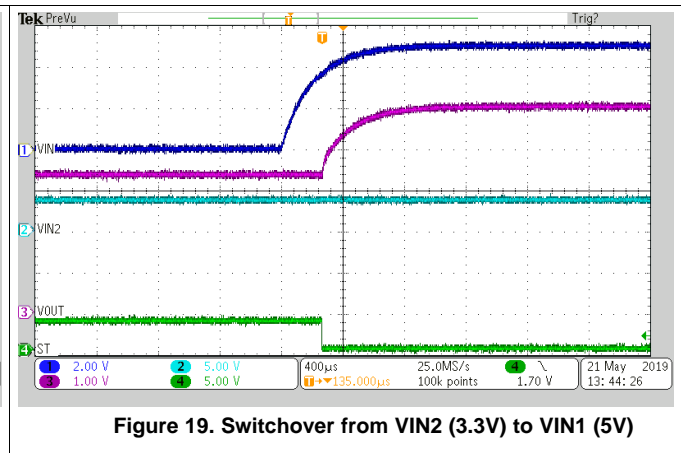

Figure 19. Switchover from VIN2 (3.3V) to VIN1 (5V)

9.2.3 ORing with Discrete MOSFET

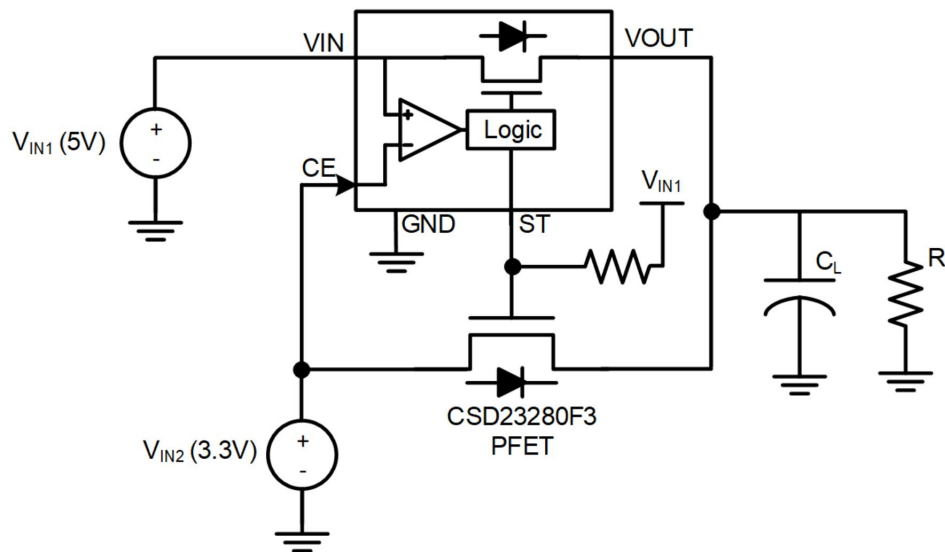

Figure 20. ORing with a Discrete MOSFET

9.2.3.1 Design Requirements

Similar to the Dual Ideal Diode circuit, the Status Output can also be used to control a discrete P-Channel MOSFET. This can be useful in applications that want to minimize the leakage current on the secondary supply, such as battery backup systems. This configuration can also be used on systems that require a lower RON on the secondary rail, useful for higher current applications.

When the Ideal Diode path is enabled, the status will be Hi-Z and pull up the gate of the external PFET to keep it off. When the main supply (VIN1) drops such that backup supply (VIN2) is higher than VIN1, the ideal diode will be disabled and pull the ST pin and the PFET gate low to turn on the discrete MOSFET path.

Typical Applications (continued)

9.2.3.2 Application Curves

The figures below show the switchover performance between VIN1 and VIN2.

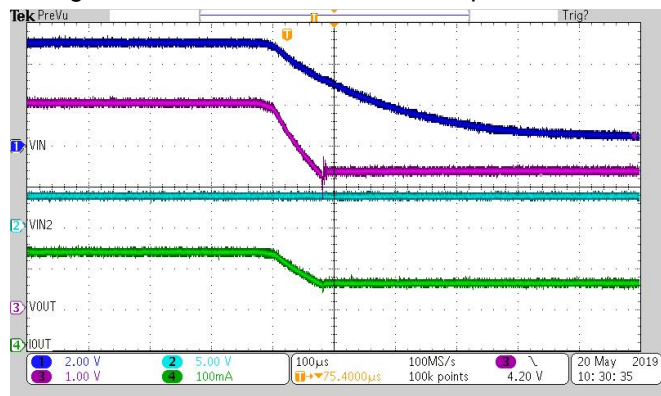

Figure 21. Switchover from VIN1 5 V to VIN2 3.3 V

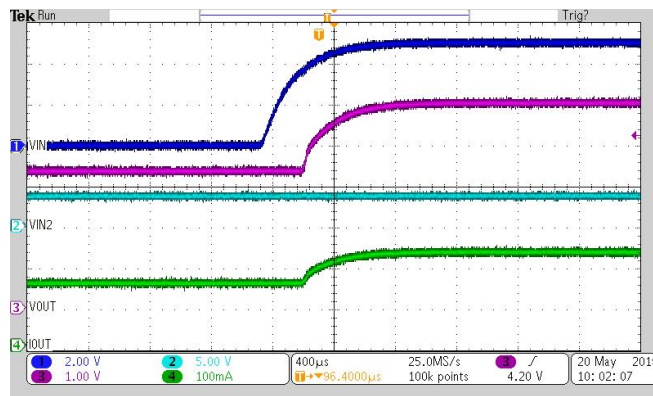

Figure 22. Switchover from VIN2 3.3 V to VIN1 5 V

10 Power Supply Recommendations

The device is designed to operate with a VIN range of 1.5 V to 5.5 V. The VIN power supply must be well regulated and placed as close to the device terminal as possible. The power supply must be able to withstand all transient load current steps. In most situations, using an input capacitance (CIN) of 1 µF is sufficient to prevent the supply voltage from dipping when the switch is turned on. In cases where the power supply is slow to respond to a large transient current or large load current step, additional bulk capacitance may be required on the input.

11 Layout

11.1 Layout Guidelines

For best performance, all traces must be as short as possible. To be most effective, the input and output capacitors must be placed close to the device to minimize the effects that parasitic trace inductances may have on normal operation. Using wide traces for VIN, VOUT and GND helps minimize the parasitic electrical effects.

11.2 Layout Example

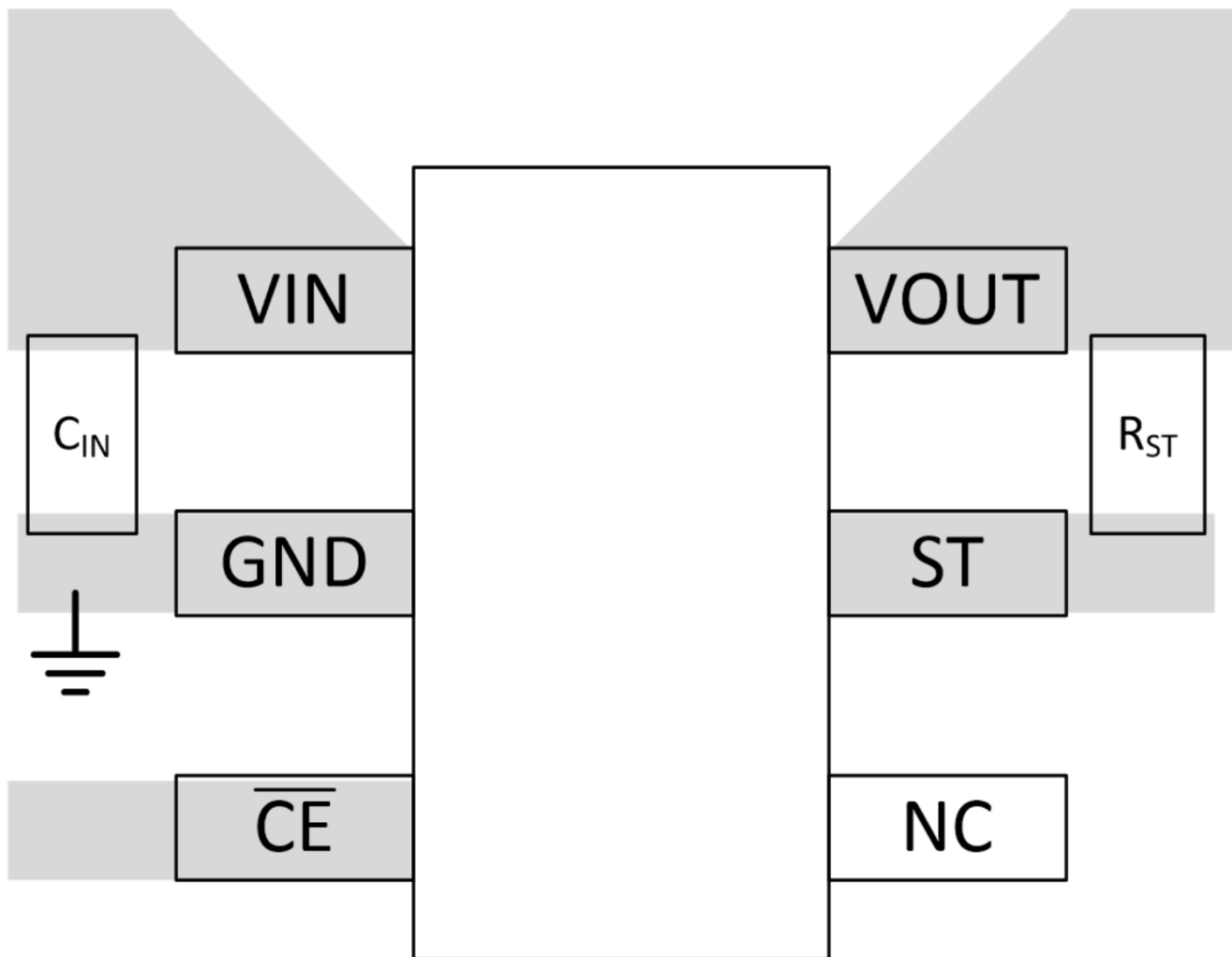

Figure 23. LM66100 Layout Example

12 Device and Documentation Support

12.1 Receiving Notification of Documentation Updates

To receive notification of documentation updates, navigate to the device product folder on ti.com. In the upper right corner, click on *Alert me* to register and receive a weekly digest of any product information that has changed. For change details, review the revision history included in any revised document.

12.2 Community Resources

The following links connect to TI community resources. Linked contents are provided "AS IS" by the respective contributors. They do not constitute TI specifications and do not necessarily reflect TI's views; see TI's [Terms of Use](#).

TI E2E™ Online Community *TI's Engineer-to-Engineer (E2E) Community*. Created to foster collaboration among engineers. At e2e.ti.com, you can ask questions, share knowledge, explore ideas and help solve problems with fellow engineers.

Design Support *TI's Design Support* Quickly find helpful E2E forums along with design support tools and contact information for technical support.

12.3 Trademarks

E2E is a trademark of Texas Instruments.

12.4 Electrostatic Discharge Caution



This integrated circuit can be damaged by ESD. Texas Instruments recommends that all integrated circuits be handled with appropriate precautions. Failure to observe proper handling and installation procedures can cause damage.

ESD damage can range from subtle performance degradation to complete device failure. Precision integrated circuits may be more susceptible to damage because very small parametric changes could cause the device not to meet its published specifications.

12.5 Glossary

[SLYZ022](#) — *TI Glossary*.

This glossary lists and explains terms, acronyms, and definitions.

13 Mechanical, Packaging, and Orderable Information

The following pages include mechanical, packaging, and orderable information. This information is the most current data available for the designated devices. This data is subject to change without notice and revision of this document. For browser-based versions of this data sheet, refer to the left-hand navigation.

PACKAGING INFORMATION

Orderable part number	Status (1)	Material type (2)	Package Pins	Package qty Carrier	RoHS (3)	Lead finish/ Ball material (4)	MSL rating/ Peak reflow (5)	Op temp (°C)	Part marking (6)
LM66100DCKR	Active	Production	SC70 (DCK) 6	3000 LARGE T&R	Yes	SN	Level-1-260C-UNLIM	-40 to 125	1CU
LM66100DCKR.A	Active	Production	SC70 (DCK) 6	3000 LARGE T&R	Yes	SN	Level-1-260C-UNLIM	-40 to 125	1CU
LM66100DCKT	Active	Production	SC70 (DCK) 6	250 SMALL T&R	Yes	SN	Level-1-260C-UNLIM	-40 to 105	1CU
LM66100DCKT.A	Active	Production	SC70 (DCK) 6	250 SMALL T&R	Yes	SN	Level-1-260C-UNLIM	-40 to 105	1CU

(1) **Status:** For more details on status, see our [product life cycle](#).

(2) **Material type:** When designated, preproduction parts are prototypes/experimental devices, and are not yet approved or released for full production. Testing and final process, including without limitation quality assurance, reliability performance testing, and/or process qualification, may not yet be complete, and this item is subject to further changes or possible discontinuation. If available for ordering, purchases will be subject to an additional waiver at checkout, and are intended for early internal evaluation purposes only. These items are sold without warranties of any kind.

(3) **RoHS values:** Yes, No, RoHS Exempt. See the [TI RoHS Statement](#) for additional information and value definition.

(4) **Lead finish/Ball material:** Parts may have multiple material finish options. Finish options are separated by a vertical ruled line. Lead finish/Ball material values may wrap to two lines if the finish value exceeds the maximum column width.

(5) **MSL rating/Peak reflow:** The moisture sensitivity level ratings and peak solder (reflow) temperatures. In the event that a part has multiple moisture sensitivity ratings, only the lowest level per JEDEC standards is shown. Refer to the shipping label for the actual reflow temperature that will be used to mount the part to the printed circuit board.

(6) **Part marking:** There may be an additional marking, which relates to the logo, the lot trace code information, or the environmental category of the part.

Multiple part markings will be inside parentheses. Only one part marking contained in parentheses and separated by a "~" will appear on a part. If a line is indented then it is a continuation of the previous line and the two combined represent the entire part marking for that device.

Important Information and Disclaimer: The information provided on this page represents TI's knowledge and belief as of the date that it is provided. TI bases its knowledge and belief on information provided by third parties, and makes no representation or warranty as to the accuracy of such information. Efforts are underway to better integrate information from third parties. TI has taken and continues to take reasonable steps to provide representative and accurate information but may not have conducted destructive testing or chemical analysis on incoming materials and chemicals. TI and TI suppliers consider certain information to be proprietary, and thus CAS numbers and other limited information may not be available for release.

In no event shall TI's liability arising out of such information exceed the total purchase price of the TI part(s) at issue in this document sold by TI to Customer on an annual basis.

OTHER QUALIFIED VERSIONS OF LM66100 :

- Automotive : [LM66100-Q1](#)

NOTE: Qualified Version Definitions:

- Automotive - Q100 devices qualified for high-reliability automotive applications targeting zero defects

TAPE AND REEL INFORMATION

QUADRANT ASSIGNMENTS FOR PIN 1 ORIENTATION IN TAPE



*All dimensions are nominal

Device	Package Type	Package Drawing	Pins	SPQ	Reel Diameter (mm)	Reel Width W1 (mm)	A0 (mm)	B0 (mm)	K0 (mm)	P1 (mm)	W (mm)	Pin1 Quadrant
LM66100DCKR	SC70	DCK	6	3000	178.0	8.4	2.25	2.45	1.2	4.0	8.0	Q3
LM66100DCKT	SC70	DCK	6	250	178.0	9.0	2.4	2.5	1.2	4.0	8.0	Q3
LM66100DCKT	SC70	DCK	6	250	180.0	8.4	2.3	2.55	1.2	4.0	8.0	Q3

TAPE AND REEL BOX DIMENSIONS

*All dimensions are nominal

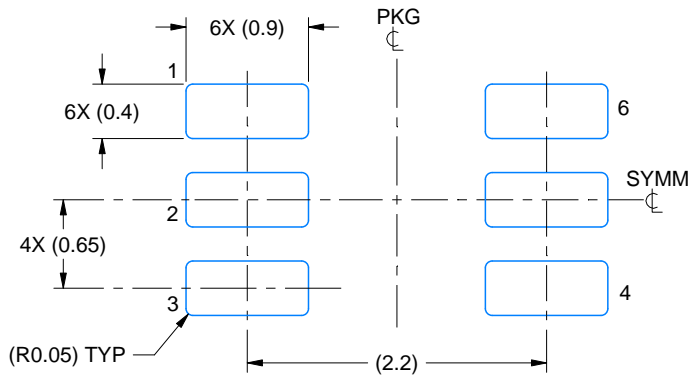
Device	Package Type	Package Drawing	Pins	SPQ	Length (mm)	Width (mm)	Height (mm)
LM66100DCKR	SC70	DCK	6	3000	208.0	191.0	35.0
LM66100DCKT	SC70	DCK	6	250	180.0	180.0	18.0
LM66100DCKT	SC70	DCK	6	250	210.0	185.0	35.0



LAND PATTERN EXAMPLE
EXPOSED METAL SHOWN
SCALE:18X

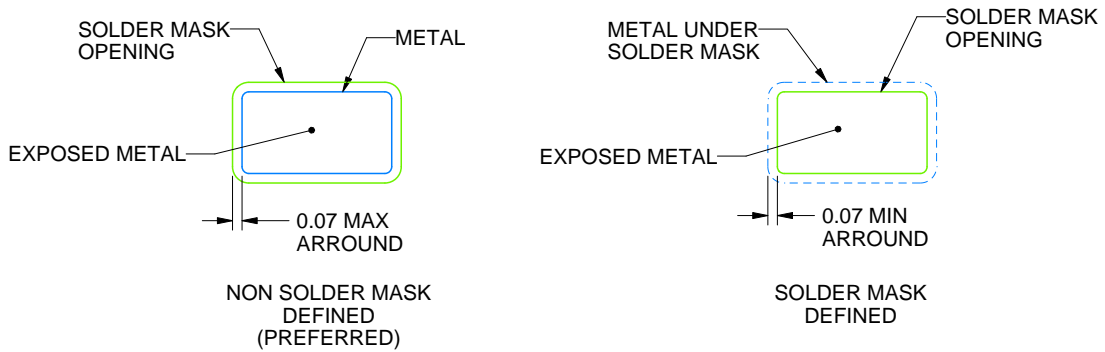

SOLDER MASK DETAILS

4214835/D 11/2024

NOTES: (continued)

- 5. Publication IPC-7351 may have alternate designs.
- 6. Solder mask tolerances between and around signal pads can vary based on board fabrication site.

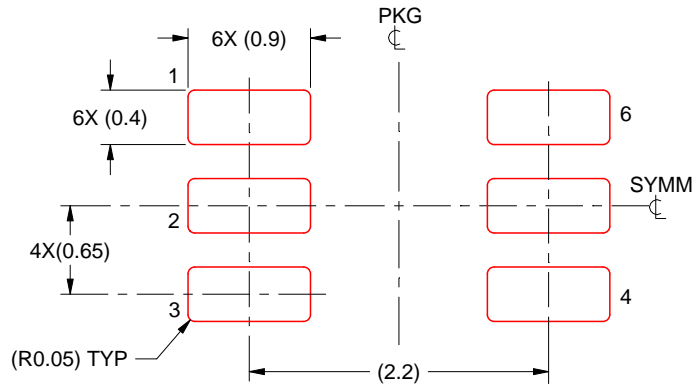

SOLDER PASTE EXAMPLE
BASED ON 0.125 THICK STENCIL
SCALE:18X

4214835/D 11/2024

NOTES: (continued)

7. Laser cutting apertures with trapezoidal walls and rounded corners may offer better paste release. IPC-7525 may have alternate design recommendations.
8. Board assembly site may have different recommendations for stencil design.

IMPORTANT NOTICE AND DISCLAIMER

TI PROVIDES TECHNICAL AND RELIABILITY DATA (INCLUDING DATASHEETS), DESIGN RESOURCES (INCLUDING REFERENCE DESIGNS), APPLICATION OR OTHER DESIGN ADVICE, WEB TOOLS, SAFETY INFORMATION, AND OTHER RESOURCES "AS IS" AND WITH ALL FAULTS, AND DISCLAIMS ALL WARRANTIES, EXPRESS AND IMPLIED, INCLUDING WITHOUT LIMITATION ANY IMPLIED WARRANTIES OF MERCHANTABILITY, FITNESS FOR A PARTICULAR PURPOSE OR NON-INFRINGEMENT OF THIRD PARTY INTELLECTUAL PROPERTY RIGHTS.

These resources are intended for skilled developers designing with TI products. You are solely responsible for (1) selecting the appropriate TI products for your application, (2) designing, validating and testing your application, and (3) ensuring your application meets applicable standards, and any other safety, security, regulatory or other requirements.

These resources are subject to change without notice. TI grants you permission to use these resources only for development of an application that uses the TI products described in the resource. Other reproduction and display of these resources is prohibited. No license is granted to any other TI intellectual property right or to any third party intellectual property right. TI disclaims responsibility for, and you fully indemnify TI and its representatives against any claims, damages, costs, losses, and liabilities arising out of your use of these resources.

TI's products are provided subject to [TI's Terms of Sale](#), [TI's General Quality Guidelines](#), or other applicable terms available either on [ti.com](#) or provided in conjunction with such TI products. TI's provision of these resources does not expand or otherwise alter TI's applicable warranties or warranty disclaimers for TI products. Unless TI explicitly designates a product as custom or customer-specified, TI products are standard, catalog, general purpose devices.

TI objects to and rejects any additional or different terms you may propose.

Copyright © 2026, Texas Instruments Incorporated

Last updated 10/2025