

LM74202-Q1 40-V, 2.2-A Integrated Ideal Diode with Overvoltage and Overcurrent Protection

1 Features

- AEC-Q100 qualified for automotive applications
 - Temperature grade 1: $-40^{\circ}\text{C} \leq T_A \leq +125^{\circ}\text{C}$
 - AEC-Q100-012 short circuit reliability Grade A
 - HBM ESD classification level 2
 - CDM ESD classification level C6
- 4.2-V to 40-V operating voltage, 42-V maximum
- Integrated reverse input polarity protection down to -40 V
- Integrated back-to-back MOSFETs with $150\text{ m}\Omega$ total RON
- Transient immunity up-to 55 V
- 0.1-A to 2.23-A adjustable current limit ($\pm 5\%$ accuracy at 1 A)
- Load protection during ISO7637 and ISO16750-2 testing
- Short to battery and short to ground protection
- Reverse current blocking for protection from output short to battery
- IMON current indicator output ($\pm 8.5\%$ accuracy)
- Low quiescent current ($285\text{ }\mu\text{A}$ in operating, $16\text{ }\mu\text{A}$ in shutdown)
- Adjustable UVLO, OVP cut off, inrush current control
- Selectable current-limiting fault response options (auto-retry, latch off, CB modes)
- Available in easy to use 16-Pin HTSSOP package

2 Applications

- [Front camera, Rear camera](#)
- [Drive assist ECU](#)
- [Telematics control unit](#)
- [Cellular module asset tracking](#)

3 Description

The LM74202-Q1 device is a compact, feature-rich 40-V integrated ideal diode with a full suite of protection features. The wide supply input range allows control of 12-V automotive battery driven applications. The device withstands and protects the loads from positive and negative supply voltages up to $\pm 40\text{ V}$. Load, source and device protection are provided with many programmable features including overcurrent, inrush current control, overvoltage and undervoltage thresholds. The internal robust protection control blocks along with the 40-V rating of the device simplifies the system design for ISO standard pulse testing.

A shutdown pin provides external control for enabling and disabling the internal FETs and places the device in a low current shutdown mode. For system status monitoring and downstream load control, the device provides fault output and precise current monitor output. The MODE pin allows flexibility to configure the device between the three current-limiting fault responses (circuit breaker, latch off, and auto-retry modes). The device monitors $V_{(IN)}$ and $V_{(OUT)}$ to provide reverse current blocking when $V_{(IN)} < (V_{(OUT)} - 10\text{mV})$. This function protects system bus from overvoltages during output short to battery faults and also helps in voltage holdup requirements during power fail and brownout conditions.

The device is available in a $5\text{ mm} \times 4.4\text{ mm}$ 16-pin HTSSOP and is fully specified over a -40°C to $+125^{\circ}\text{C}$ temperature range.

Device Information⁽¹⁾

PART NUMBER	PACKAGE	BODY SIZE (NOM)
LM74202-Q1	HTSSOP (16)	5.00 mm x 4.40 mm

(1) For all available packages, see the orderable addendum at the end of the data sheet.

Simplified Schematic

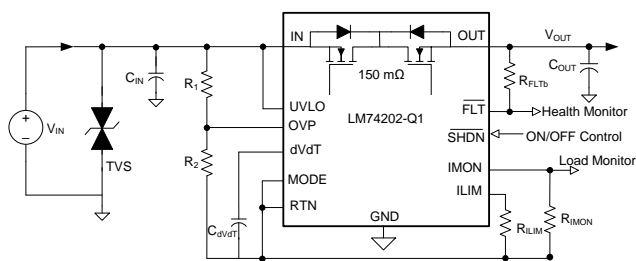

ISO16750-2 Load Dump Pulse 5b Performance at 12 V

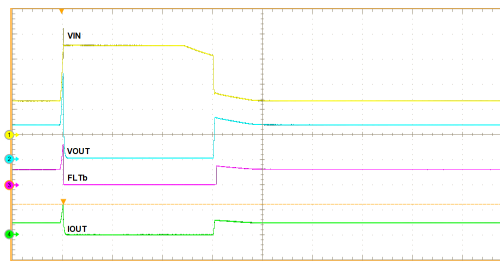

Table of Contents

1 Features	1	8.4 Device Functional Modes.....	24
2 Applications	1	9 Application and Implementation	25
3 Description	1	9.1 Application Information.....	25
4 Revision History	2	9.2 Typical Application	25
5 Pin Configuration and Functions	3	10 Power Supply Recommendations	29
6 Specifications	4	10.1 Transient Protection	29
6.1 Absolute Maximum Ratings	4	11 Layout	30
6.2 ESD Ratings.....	4	11.1 Layout Guidelines	30
6.3 Recommended Operating Conditions.....	4	11.2 Layout Example	31
6.4 Thermal Information	4	12 Device and Documentation Support	32
6.5 Electrical Characteristics.....	5	12.1 Documentation Support	32
6.6 Timing Requirements	6	12.2 Receiving Notification of Documentation Updates	32
6.7 Typical Characteristics	8	12.3 Community Resources.....	32
7 Parameter Measurement Information	11	12.4 Trademarks	32
8 Detailed Description	12	12.5 Electrostatic Discharge Caution.....	32
8.1 Overview	12	12.6 Glossary	32
8.2 Functional Block Diagram	13	13 Mechanical, Packaging, and Orderable	32
8.3 Feature Description.....	14	Information	32

4 Revision History

DATE	REVISION	NOTES
September 2019	*	Initial release

5 Pin Configuration and Functions

PWP Package
16-Pin HTSSOP With Exposed Thermal Pad
Top View

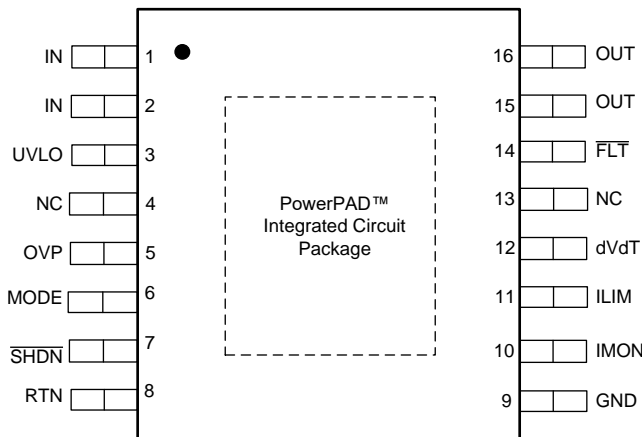

Pin Functions

PIN		TYPE	DESCRIPTION
NO.	NAME		
1, 2	IN	P	Input supply voltage. See IN, OUT, RTN and GND Pins section.
3	UVLO	I	Input for setting the programmable Undervoltage Lockout threshold. An undervoltage event turns off the internal FET and asserts FLT to indicate power failure. If the Undervoltage Lockout function is not needed, the UVLO terminal must be connected to the IN terminal. See Undervoltage Lockout (UVLO) section.
4, 13	NC	—	No internal connection. These pins can be connected to RTN for enhanced thermal performance.
5	OVP	I	Input for setting the programmable Overvoltage Protection threshold. An overvoltage event turns off the internal FET and asserts FLT to indicate the overvoltage fault. See Overvoltage Protection (OVP) section.
6	MODE	I	Mode selection pin for overload fault response. See the Device Functional Modes section.
7	$\overline{\text{SHDN}}$	I	Shutdown pin. Pulling $\overline{\text{SHDN}}$ low enters the device into low-power shutdown mode. Cycling SHDN pin voltage resets the device that has latched off due to a fault condition. See Low Current Shutdown Control (SHDN) section.
8	RTN	—	Reference for device internal control circuits. If reverse input polarity protection is not required, this pin can be connected to GND. See IN, OUT, RTN and GND Pins section.
9	GND	—	Connect GND to system ground. See IN, OUT, RTN and GND Pins section.
10	IMON	O	Analog current monitor output. This pin sources a scaled down ratio of current through the internal FET. A resistor from this pin to RTN converts current to proportional voltage. If pin is unused, leave pin floating. See Current Monitoring section.
11	ILIM	I/O	A resistor from this pin to RTN sets the overload and short-circuit current limit. See the Overload and Short Circuit Protection section.
12	dVdT	I/O	A capacitor from this pin to RTN sets output voltage slew rate. See the Hot Plug-In and In-Rush Current Control section.
14	$\overline{\text{FLT}}$	O	Fault event indicator. Indicator is an open drain output. If indicator is unused, leave indicator floating. See FAULT Response section.
15,16	OUT	P	Power output of the device. See IN, OUT, RTN and GND Pins section.
PowerPAD		—	PowerPAD integrated circuit package must be connected to RTN plane on PCB using multiple vias for enhanced thermal performance. PowerPAD is not internally connected to RTN. Do not use the PowerPAD as the only electrical connection to RTN.

6 Specifications

6.1 Absolute Maximum Ratings

over operating free-air temperature range, all voltages referred to GND (unless otherwise noted)⁽¹⁾

		MIN	MAX	UNIT
IN, IN-OUT		-42	42	V
IN, IN-OUT (350ms transient), T _A = 25°C		-55	55	
[IN, OUT, $\overline{\text{FLT}}$, UVLO, $\overline{\text{SHDN}}$] to RTN		-0.3	42	
[OVP, dVdT, ILIM, IMON, MODE] to RTN		-0.3	5	
RTN		-42	0.3	
I $\overline{\text{FLT}}$, I _{dVdT} , I $\overline{\text{SHDN}}$	Sink current	10		mA
I _{dVdT} , I _{ILIM} , I _{IMON}	Source Current	Internally limited	Internally limited	
T _J	Operating junction temperature	-40	150	°C
	Transient junction temperature	-65	T _(TSD)	°C
T _{stg}	Storage Temperature	-65	150	°C

(1) Stresses beyond those listed under Absolute Maximum Ratings may cause permanent damage to the device. These are stress ratings only, which do not imply functional operation of the device at these or any other conditions beyond those indicated under Recommended Operating Conditions. Exposure to absolute-maximum-rated conditions for extended periods may affect device reliability.

6.2 ESD Ratings

			VALUE	UNIT
V _(ESD)	Electrostatic discharge	Human body model (HBM), per AEC Q100-002 ⁽¹⁾	±2000	V
		Charged device model (CDM), per AEC Q100-011	±1000	
		All pins		

(1) AEC Q100-002 indicates that HBM stressing shall be in accordance with the ANSI/ESDA/JEDEC JS-001 specification.

6.3 Recommended Operating Conditions

over operating free-air temperature range (unless otherwise noted)

		MIN	NOM	MAX	UNIT
IN	Input voltage range	-40		40	V
UVLO, OUT, $\overline{\text{FLT}}$		0		40	
OVP, dVdT, ILIM, IMON, $\overline{\text{SHDN}}$		0		4	
ILIM	Resistance	5.36		120	kΩ
IMON		1			
IN, OUT	External capacitance	0.1	1		μF
dVdT		10			nF
T _J	Operating junction temperature range	-40	25	125	°C

6.4 Thermal Information

THERMAL METRIC ⁽¹⁾		LM74202-Q1	UNIT
		PWP (HTSSOP)	
		16 PINS	
R _{θJA}	Junction-to-ambient thermal resistance	38.6	°C/W
R _{θJC(top)}	Junction-to-case (top) thermal resistance	22.7	°C/W
R _{θJB}	Junction-to-board thermal resistance	18.2	°C/W
Ψ _{JT}	Junction-to-top characterization parameter	0.5	°C/W
Y _{JB}	Junction-to-board characterization parameter	18	°C/W
R _{θJC(bot)}	Junction-to-case (bottom) thermal resistance	1.5	°C/W

(1) For more information about traditional and new thermal metrics, see the [Semiconductor and IC Package Thermal Metrics](#) application report.

6.5 Electrical Characteristics

–40°C ≤ T_A = T_J ≤ +125°C, V_(IN) = 12 V, V_(SHDN) = 2 V, R_(ILIM) = 120 kΩ, IMON = $\overline{\text{FLT}}$ = OPEN, C_(IN) = 0.1 μF, C_(OUT) = 1 μF, C_(dVdT) = OPEN.

(All voltages referenced to GND, (unless otherwise noted))

PARAMETER		TEST CONDITIONS	MIN	TYP	MAX	UNIT
SUPPLY VOLTAGE						
V _(IN)	Operating input voltage		4.2		40	V
V _{PORR}	Internal POR Threshold, Rising		3.89	4	4.14	V
V _{PORHys}	Internal POR Hysteresis		55	275	305	mV
I _{QON}	Supply Current with device enabled	V _{IN} = 12V Enabled: V _(SHDN) = 2 V,		285	390	μA
I _{QOFF}	Supply Current with device disabled	V _{IN} = 12V, V _(SHDN) = 0 V		16	32	μA
I _{VINR}	Reverse Input supply current	V _(IN) = -40 V, V _(OUT) = 0 V			50	μA
UNDERVOLTAGE LOCKOUT (UVLO) INPUT						
V _(UVLOR)	UVLO Threshold Voltage, Rising		1.175	1.19	1.25	V
V _(UVLOR)	UVLO Threshold Voltage, Falling		1.08	1.1	1.126	V
I _(UVLO)	UVLO Input leakage current	0 V ≤ V _(UVLO) ≤ 40 V	-100		100	nA
LOW IQ SHUTDOWN (SHDNb) INPUT						
V _(SHDN)	Output voltage	I _(SHDN) = 0.1μA	2	2.7	3.4	V
V _(SHUTF)	SHDN Threshold Voltage for Low IQ Shutdown, Falling		0.45			V
V _(SHUTFR)	SHDN Threshold, Rising				0.96	V
I _(SHDN)	Input current	V _(SHDN) = 0.4 V	-10			μA
OVER VOLTAGE PROTECTION (OVP) INPUT						
V _(SEL_OVP)	Factory Set OV Clamp Select Threshold		180	200	240	mV
V _(OVPR)	Over-Voltage Threshold Voltage, Rising		1.175	1.19	1.225	V
V _(OVPF)	Over-Voltage Threshold Voltage, Falling		1.085		1.125	
I _(OVP)	OVP Input Leakage Current	0V ≤ V _(OVP) ≤ 4V	-100	0	100	nA
OUTPUT RAMP CONTROL (dVdT)						
I _(dVdT)	dVdT Charging Current	V _(dVdT) = 0 V	4	4.7	5.82	μA
R _(dVdT)	dVdT Discharging Resistance	SHDN = 0 V, with I _(dVdT) = 10mA sinking		28		Ω
GAIN _(dVdT)	dVdT to OUT Gain	$\Delta V_{(OUT)} / \Delta V_{(dVdT)}$	23.75	24.63	25.5	V/V
CURRENT LIMIT PROGRAMMING (ILIM)						
V _(ILIM)	ILIM Bias Voltage			1		V
I _(OL)	Overload Current Limit	R _(ILIM) = 120 kΩ, V _(IN) -V _(OUT) =1V	0.085	0.1	0.115	A
		R _(ILIM) = 12 kΩ, V _(IN) -V _(OUT) =1V	0.95	1	1.05	
		R _(ILIM) = 8 kΩ, V _(IN) -V _(OUT) =1V	1.425	1.5	1.575	
		R _(ILIM) = 5.36 kΩ, V _(IN) -V _(OUT) =1V	2.11	2.23	2.35	
I _(OL_R-OPEN)		R _(ILIM) = OPEN, Open Resistor Current Limit		0.055		
I _(OL_R-SHORT)		R _(ILIM) = SHORT, Shorted Resistor Current Limit		0.095		
I _(CB)	Circuit breaker detection threshold	R _(ILIM) = 120 kΩ, MODE = open	0.045	0.073	0.11	A
I _(CB)	Circuit breaker detection threshold	R _(ILIM) = 5.36 kΩ, MODE = open	2	2.21	2.4	A
I _(SCL)	Short-Circuit Current Limit	R _(ILIM) = 120 kΩ, V _(IN) -V _(OUT) =5V	0.08	0.1	0.12	A
		R _(ILIM) = 8 kΩ, V _(IN) -V _(OUT) =5V	1.425	1.5	1.575	A
		R _(ILIM) = 5.36 kΩ, V _(IN) -V _(OUT) =5V	2.11	2.23	2.35	A

Electrical Characteristics (continued)

$-40^{\circ}\text{C} \leq T_A = T_J \leq +125^{\circ}\text{C}$, $V_{(IN)} = 12\text{ V}$, $V_{(SHDN)} = 2\text{ V}$, $R_{(ILIM)} = 120\text{ k}\Omega$, $IMON = \overline{FLT} = \text{OPEN}$, $C_{(IN)} = 0.1\text{ }\mu\text{F}$, $C_{(OUT)} = 1\text{ }\mu\text{F}$, $C_{(dvdT)} = \text{OPEN}$.

(All voltages referenced to GND, (unless otherwise noted))

PARAMETER		TEST CONDITIONS	MIN	TYP	MAX	UNIT
$I_{(FASTRIIP)}$	Fast-trip comparator threshold			$1.87 \times I_{(OL)} + 0.015$		A
CURRENT MONITOR OUTPUT (IMON)						
$GAIN_{(IMON)}$	Gain Factor $I_{(IMON)}:I_{(OUT)}$	$0.1\text{ A} \leq I_{(OUT)} \leq 2\text{ A}$	72	78.28	85	$\mu\text{A/A}$
PASS FET OUTPUT (OUT)						
R_{ON}	IN to OUT Total ON Resistance	$0.1\text{ A} \leq I_{(OUT)} \leq 2\text{ A}, T_J = 25^{\circ}\text{C}$	130	150	168	m Ω
		$0.1\text{ A} \leq I_{(OUT)} \leq 2\text{ A}, -40^{\circ}\text{C} \leq T_J \leq 85^{\circ}\text{C}$		150	220	
		$0.1\text{ A} \leq I_{(OUT)} \leq 2\text{ A}, -40^{\circ}\text{C} \leq T_J \leq 125^{\circ}\text{C}$	78	150	265	
$I_{(IKG)(OUT)}$	OUT Leakage Current in Off State	$V_{(IN)} = 40\text{ V}$, $V_{(SHDN)} = 0\text{ V}$, $V_{(OUT)} = 0\text{ V}$, Sourcing			12	μA
$I_{(IKG)(OUT)}$	OUT Leakage Current in Off State	$V_{(IN)} = 0\text{ V}$, $V_{(SHDN)} = 0\text{ V}$, $V_{(OUT)} = 24\text{ V}$, Sinking	-11		11	μA
		$V_{(IN)} = -40\text{ V}$, $V_{(SHDN)} = 0\text{ V}$, $V_{(OUT)} = 0\text{ V}$, Sinking	-40	-18	50	
$V_{(REVTH)}$	$V_{(IN)}-V_{(OUT)}$ Threshold for Reverse Protection Comparator, Falling		-16.2	-10	-5	mV
$V_{(FWDTH)}$	$V_{(IN)}-V_{(OUT)}$ Threshold for Reverse Protection Comparator, Rising		85	96	110	mV
FAULT FLAG (FLTb): ACTIVE LOW						
$R_{(FLT)}$	\overline{FLT} Pull-Down Resistance	$V_{(OVP)} = 2\text{ V}$, $I_{(FLT)} = 5\text{ mA}$ sinking		350		Ω
$I_{(FLT)}$	\overline{FLT} Input Leakage Current	$0\text{ V} \leq V_{(FLT)} \leq 40\text{ V}$	-200		200	nA
THERMAL SHUT DOWN (TSD)						
$T_{(TSD)}$	TSD Threshold, rising			157		$^{\circ}\text{C}$
	TSD hysteresis			10.1		$^{\circ}\text{C}$
MODE						
MODE_SEL	Thermal fault mode selection	MODE = 402 k Ω to RTN				Current limiting with latch
		MODE = Open				Circuit breaker mode with auto-retry
		MODE = Short to RTN				Current limiting with auto-retry

6.6 Timing Requirements

$-40^{\circ}\text{C} \leq T_A = T_J \leq +125^{\circ}\text{C}$, $V_{(IN)} = 12\text{ V}$, $V_{(SHDN)} = 2\text{ V}$, $R_{(ILIM)} = 120\text{ k}\Omega$, $IMON = \overline{FLT} = \text{OPEN}$, $C_{(IN)} = 0.1\text{ }\mu\text{F}$, $C_{(OUT)} = 1\text{ }\mu\text{F}$, $C_{(dvdT)} = \text{OPEN}$.

(All voltages referenced to GND, (unless otherwise noted))

PARAMETER		TEST CONDITIONS	MIN	NOM	MAX	UNIT
UVLO INPUT						
UVLO Turn On Delay	$UVLO_t_{ON(dly)}$	$UVLO\uparrow$ (100mV above $V_{(UVLOR)}$) to $V_{(OUT)} = 100\text{ mV}$, $C_{(dvdT)} = \text{Open}$		80		μs
	$UVLO_t_{ON(dly)}$	$UVLO\uparrow$ (100mV above $V_{(UVLOR)}$) to $V_{(OUT)} = 100\text{ mV}$, $C_{(dvdT)} \geq 10\text{ nF}$, [$C_{(dvdT)}$ in nF]		$80+14.5 \times C_{(dvdT)}$		
UVLO Turn-Off delay	$UVLO_t_{off(dly)}$	$UVLO\downarrow$ (100mV below $V_{(UVLOF)}$) to $\overline{FLT}\downarrow$		9		μs
SHUTDOWN INPUT						

Timing Requirements (continued)

$-40^{\circ}\text{C} \leq T_A = T_J \leq +125^{\circ}\text{C}$, $V_{(IN)} = 12\text{ V}$, $V_{(SHDN)} = 2\text{ V}$, $R_{(ILIM)} = 120\text{ k}\Omega$, $IMON = \overline{FLT} = \text{OPEN}$, $C_{(IN)} = 0.1\text{ }\mu\text{F}$, $C_{(OUT)} = 1\text{ }\mu\text{F}$, $C_{(dVdT)} = \text{OPEN}$.

(All voltages referenced to GND, (unless otherwise noted))

PARAMETER		TEST CONDITIONS	MIN	NOM	MAX	UNIT
SHUTDOWN Exit delay	SHDN_t _{on(dly)}	$\overline{SHDN} \uparrow$ (above $V_{(SHUTR)}$ to $V_{(OUT)} = 100\text{mV}$, $C_{(dVdT)} \geq 10\text{ nF}$, [$C_{(dVdT)}$ in nF])		350+14 .5 x $C_{(dVdT)}$		μs
	SHDN_t _{on(dly)}	$\overline{SHDN} \uparrow$ (above $V_{(SHUTR)}$ to $V_{(OUT)} = 100\text{mV}$, $C_{(dVdT)} = \text{Open}$)		355		
SHUTDOWN Entry delay	SHDN_t _{off(dly)}	$\overline{SHDN} \downarrow$ (below $V_{(SHUTF)}$ to $\overline{FLT} \downarrow$)		10		μs
OVP INPUT						
OVP Exit delay	t _{OVP(dly)}	OVP \downarrow (20mV below $V_{(OVPR)}$ to $V_{(OUT)} = 100\text{mV}$)		205		μs
OVP Disable delay	t _{OVP(dly)}	OVP \uparrow (20mV above $V_{(OVPR)}$ to $\overline{FLT} \downarrow$)		2		μs
CURRENT LIMIT						
Fast-Trip Comparator Delay	t _{FASTTRIP(dly)}	$I_{(OUT)} = 1.5 \times I_{(FASTTRIP)}$		170		ns
REVERSE CURRENT BLOCKING COMPARATOR						
RCB comparator delay	t _{REV(dly)}	$(V_{(IN)} - V_{(OUT)}) \downarrow$ (100mV overdrive below $V_{(REVTH)}$) to internal FET OFF		1.29		μs
		$(V_{(IN)} - V_{(OUT)}) \downarrow$ (10mV overdrive below $V_{(REVTH)}$) to $\overline{FLT} \downarrow$		40		μs
	t _{FWD(dly)}	$(V_{(IN)} - V_{(OUT)}) \uparrow$ (10mV overdrive above $V_{(FWDTH)}$) to $\overline{FLT} \uparrow$		60		μs
THERMAL SHUTDOWN						
Retry Delay in TSD	t _{retry}			540		ms
OUTPUT RAMP TIME						
Output Ramp Time	t _{dVdT}	$\overline{SHDN} \uparrow$ to $V_{(OUT)} = V_{(IN)}$		1.6		ms
		$\overline{SHDN} \uparrow$ to $V_{(OUT)} = V_{(IN)}$, with $C_{(dVdT)} = 47\text{nF}$		10		ms
FAULT FLAG						
FLT assertion delay in circuit breaker mode	t _{CB(dly)}	MODE = OPEN, Delay from $I_{(out)} > I_{(lim)}$ to $\overline{FLT} \downarrow$ (and internal FET turned off)		4		ms
Retry Delay in circuit breaker mode	t _{CBretry(dly)}	MODE = OPEN, $C_{(dVdT)} = \text{Open}$. $I_{(out)} > I_{(lim)}$. Delay from $\overline{FLT} \downarrow$ to $V_{(dVdT)} = 50\text{mV}$ (Rising)		540		ms
PGOOD delay time	t _{PGOODR}	Delay for rising \overline{FLT} edge		1.8		ms
	t _{PGOODF}	Delay for falling \overline{FLT} edge		900		μs

6.7 Typical Characteristics

$T_A = 25\text{ }^\circ\text{C}$, $V_{(IN)} = 12\text{ V}$, $V_{(SHDN)} = 2\text{ V}$, $R_{(LIM)} = 120\text{ k}\Omega$, $IMON = \overline{FLT} = OPEN$, $C_{(IN)} = 0.1\text{ }\mu\text{F}$, $C_{(OUT)} = 1\text{ }\mu\text{F}$, $C_{(dVdT)} = OPEN$.
(Unless otherwise noted)

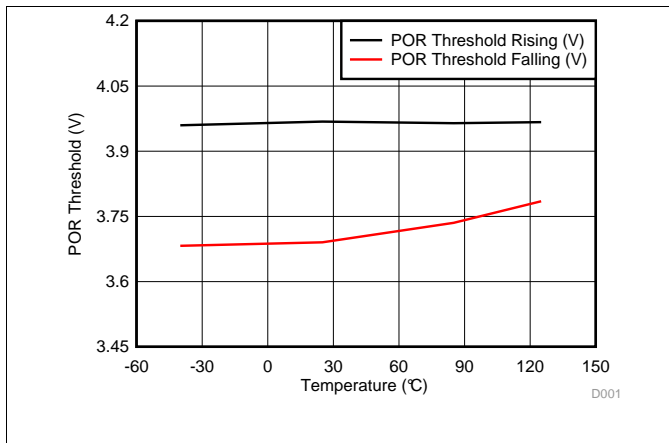

Figure 1. POR Threshold (V_{POR}) vs Temperature

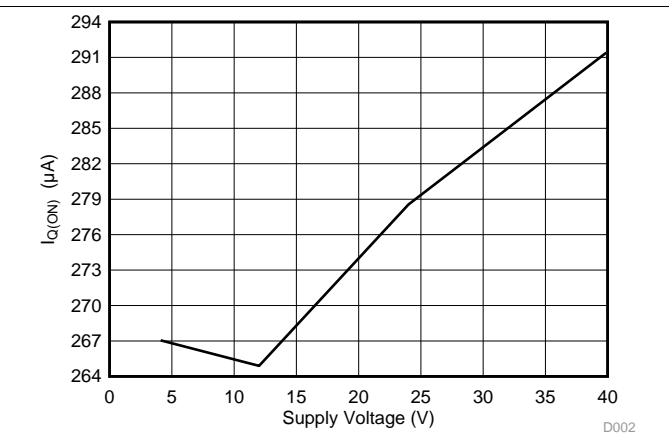

Figure 2. Supply Current ON (I_{QON}) vs Supply Voltage (V_{IN})

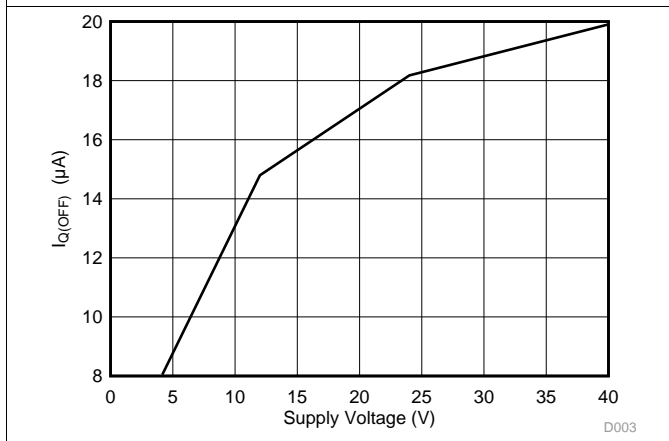

Figure 3. Supply Current OFF (I_{QOFF}) vs Supply Voltage (V_{IN})

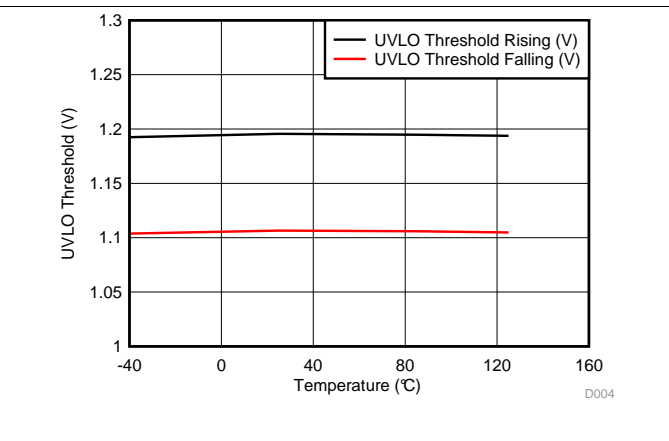

Figure 4. UVLO Thresholds (V_{UVLOR} , V_{UVLOF}) vs Temperature

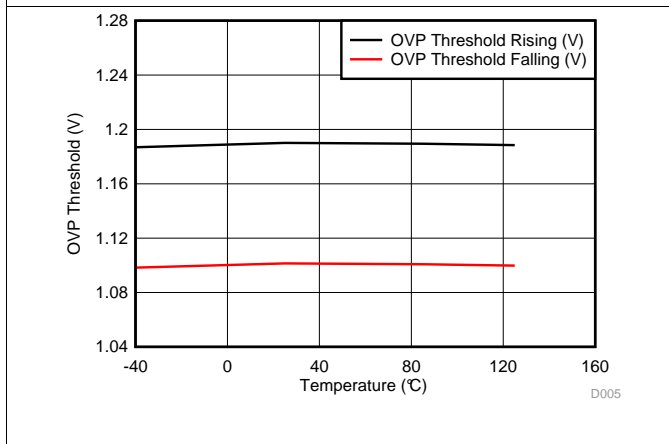

Figure 5. OVP Thresholds (V_{OVPR} , V_{OVPF}) vs Temperature

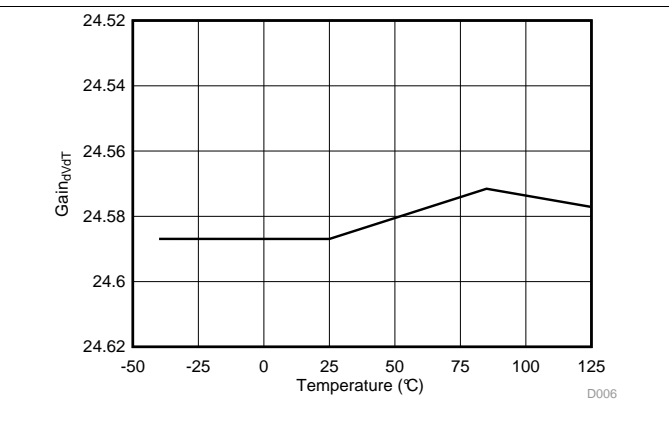

Figure 6. $GAIN_{(dVdT)}$ vs Temperature

Typical Characteristics (continued)

$T_A = 25\text{ }^\circ\text{C}$, $V_{(IN)} = 12\text{ V}$, $V_{(SHDN)} = 2\text{ V}$, $R_{(ILIM)} = 120\text{ k}\Omega$, $IMON = \overline{FLT} = \text{OPEN}$, $C_{(IN)} = 0.1\text{ }\mu\text{F}$, $C_{(OUT)} = 1\text{ }\mu\text{F}$, $C_{(dVdT)} = \text{OPEN}$.
(Unless otherwise noted)

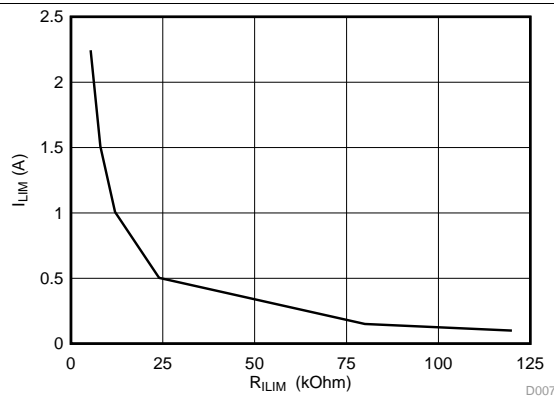

Figure 7. I_{LIM} vs R_{ILIM}

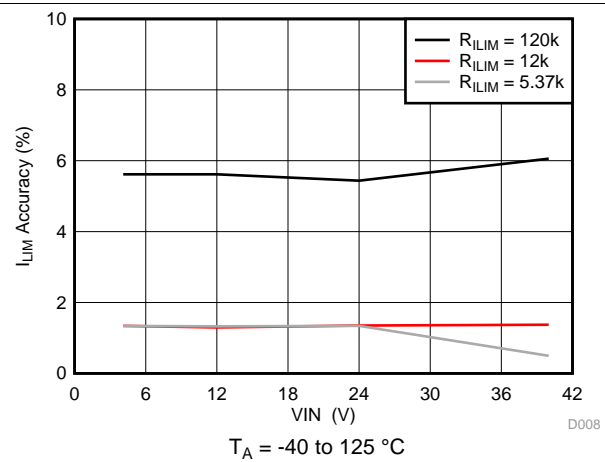

Figure 8. I_{LIM} Accuracy vs Supply Voltage

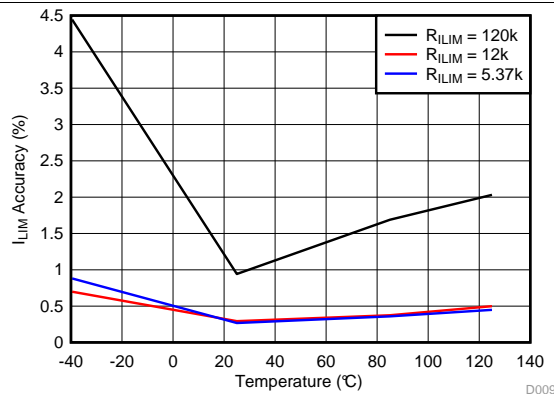

Figure 9. I_{LIM} Accuracy vs Temperature with $V_{IN} = 12\text{ V}$

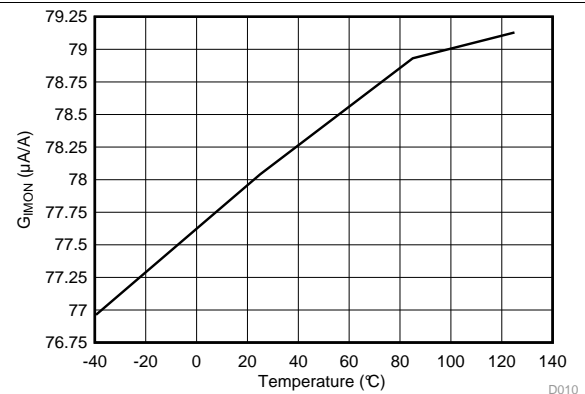

Figure 10. $GAIN_{(IMON)}$ vs Temperature

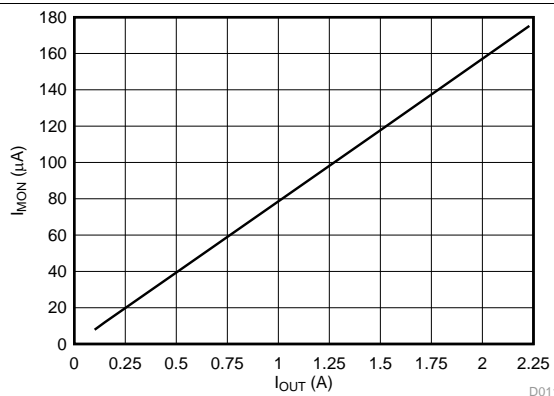

Figure 11. I_{MON} vs I_{OUT}

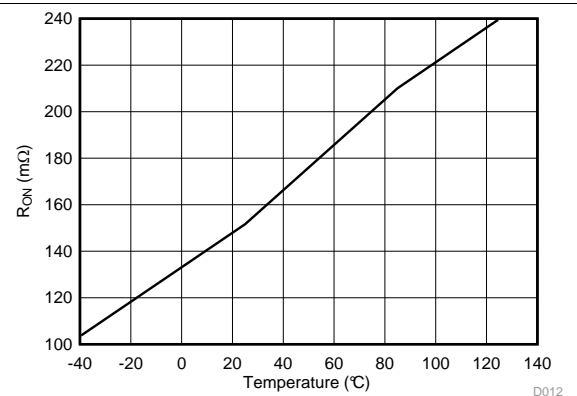
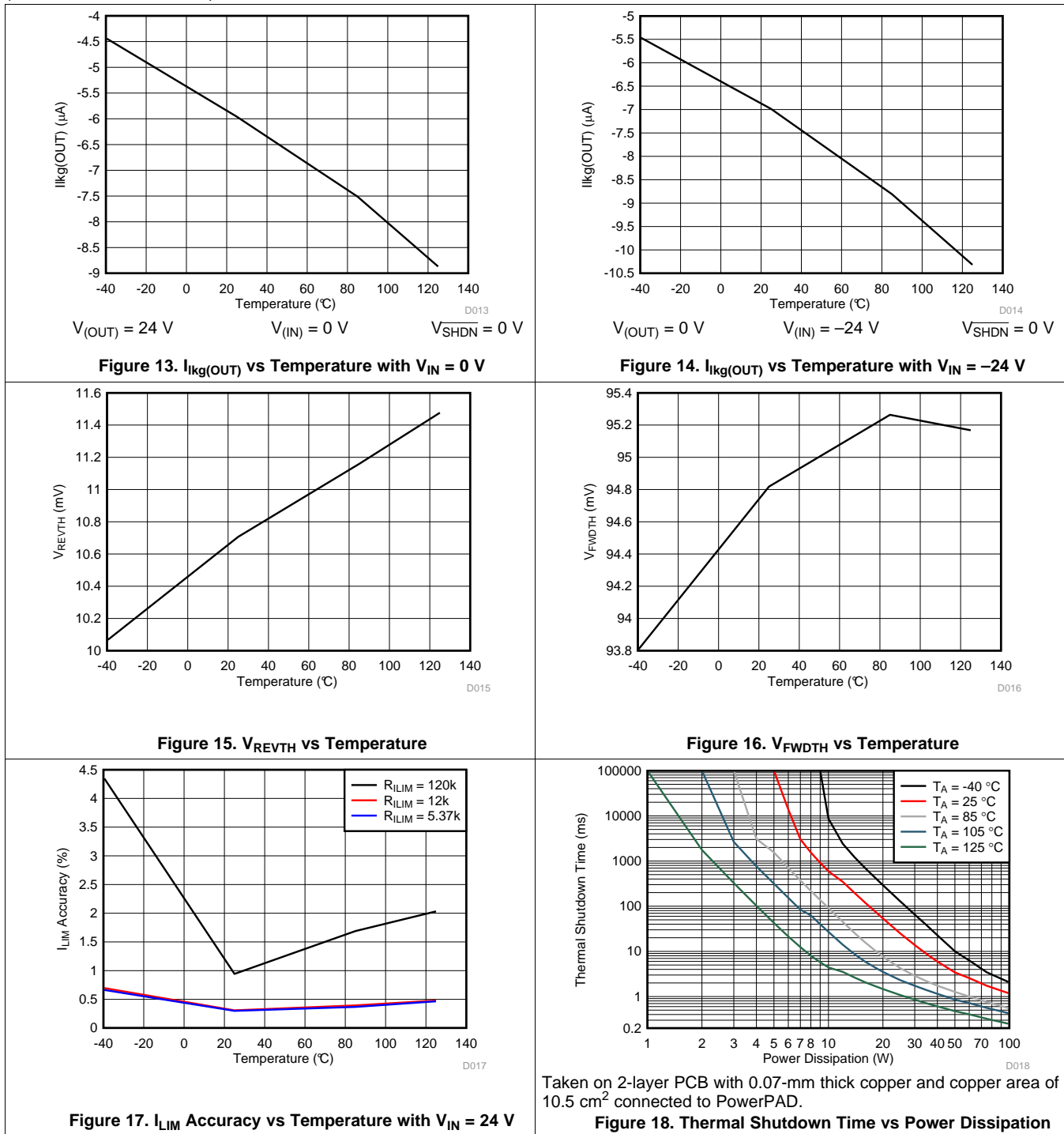

Figure 12. R_{ON} vs Temperature

Typical Characteristics (continued)

$T_A = 25\text{ }^\circ\text{C}$, $V_{(IN)} = 12\text{ V}$, $V_{(SHDN)} = 2\text{ V}$, $R_{(ILIM)} = 120\text{ k}\Omega$, $IMON = \overline{FLT} = \text{OPEN}$, $C_{(IN)} = 0.1\text{ }\mu\text{F}$, $C_{(OUT)} = 1\text{ }\mu\text{F}$, $C_{(dVdT)} = \text{OPEN}$.
(Unless otherwise noted)



7 Parameter Measurement Information

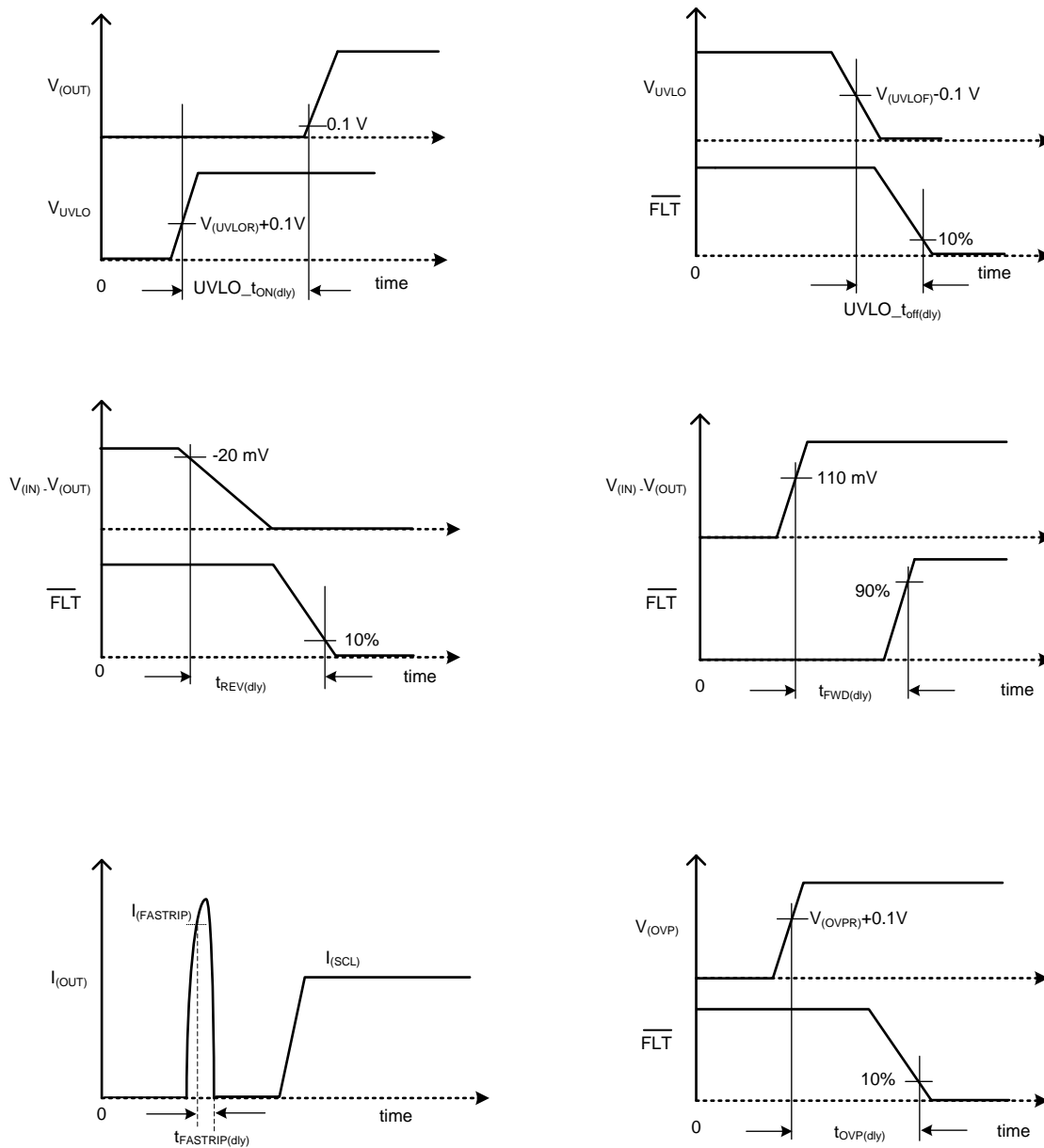

Figure 19. Timing Waveforms

8 Detailed Description

8.1 Overview

LM74202-Q1 is an ideal diode with integrated back-to-back FETs and enhanced built-in protection circuitry. It provides robust protection for all systems and applications powered from 4.2 V to 40 V. The device integrates reverse battery input, reverse current, overvoltage, undervoltage, overcurrent and short circuit protection. The precision overcurrent limit ($\pm 5\%$ at 1A) helps to minimize over design of the input power supply, while the fast response short circuit protection immediately isolates the load from input when a short circuit is detected. The device allows the user to program the overcurrent limit threshold between 0.1 A and 2.23 A with an external resistor. The device monitors the bus voltage for brown-out and overvoltage protection, asserting the FLTB pin to notify downstream systems.

The device is designed to protect systems such as ADAS camera supplies against sudden output short to battery events. The device monitors $V_{(IN)}$ and $V_{(OUT)}$ to provide true reverse blocking from output when output short to battery fault condition or input power fail condition is detected. The internal robust protection control blocks of the LM74202-Q1 device along with its ± 40 V rating helps to simplify the system designs for the various ISO and LV124 compliance ensuring complete protection of the load and the device.

The device monitors $V_{(IN)}$ and $V_{(OUT)}$ to provide true reverse current blocking when a reverse condition or input power failure condition is detected. The LM74202-Q1 device is also designed to control redundant power supply systems.

Additional features of the LM74202-Q1 device include:

- Reverse input battery protection
- Reverse current blocking
- Current monitor output for health monitoring of the system
- Electronic circuit breaker operation with overload timeout using MODE pin
- A choice of latch off or automatic restart mode response during current limit fault using MODE pin
- Over temperature protection to safely shutdown in the event of an overcurrent event
- De-glitched fault reporting for brown-out and overvoltage faults
- Look ahead overload current fault indication (see the [Look Ahead Overload Current Fault Indicator](#) section)

8.2 Functional Block Diagram

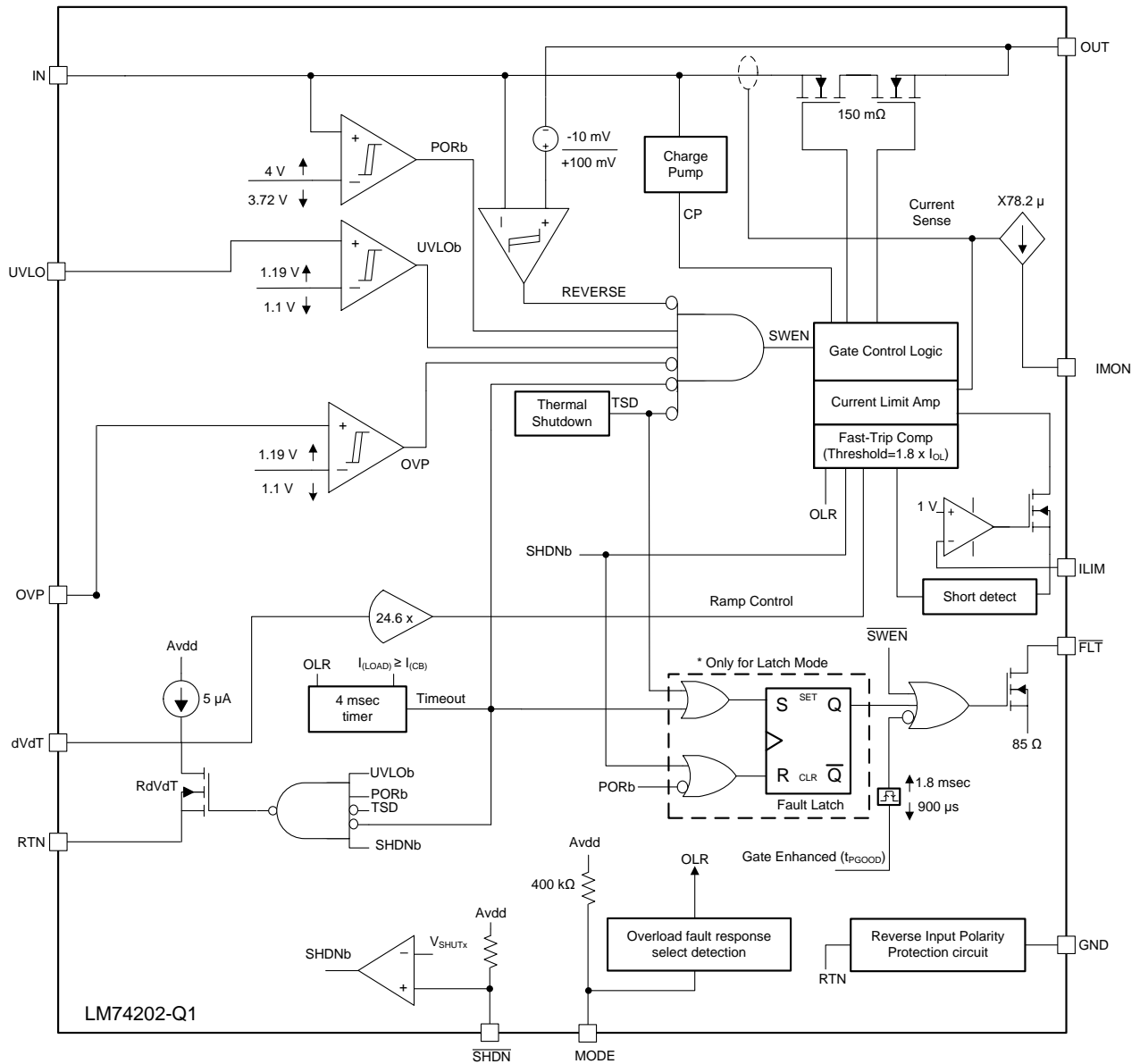

8.3 Feature Description

8.3.1 Undervoltage Lockout (UVLO)

This section describes the undervoltage comparator input. When the voltage at UVLO pin falls below $V_{(UVLOF)}$ during input power fail or input undervoltage fault, the internal FET quickly turns off and \overline{FLT} is asserted. The UVLO comparator has a hysteresis of 90 mV. To set the input UVLO threshold, connect a resistor divider network from IN supply to UVLO terminal to RTN as shown in Figure 20.

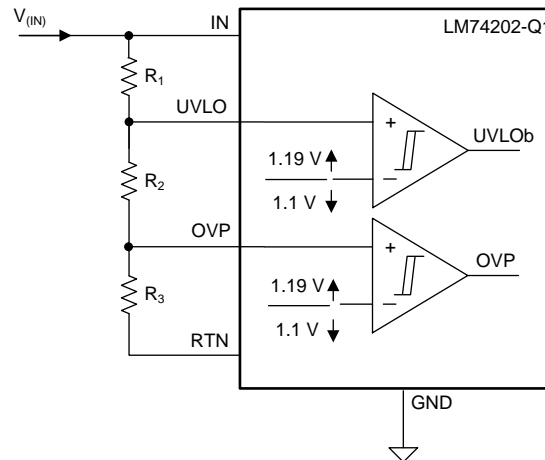

Figure 20. UVLO and OVP Thresholds Set by R_1 , R_2 and R_3

If the undervoltage lockout (UVLO) function is not needed, the UVLO terminal must be connected to the IN terminal. UVLO terminal must not be left floating.

The device also implements an internal power ON reset (POR) function on the IN terminal. The device disables the internal circuitry when the IN terminal voltage falls below internal POR threshold $V_{(PORF)}$. The internal POR threshold has a hysteresis of 275 mV.

8.3.2 Overvoltage Protection (OVP)

The device incorporates circuitry to protect the system during overvoltage conditions. This device features an overvoltage cut off functionality. A voltage more than $V_{(OVPR)}$ on OVP pin turns off the internal FET and protects the downstream load. To program the OVP threshold, connect a resistor divider from IN supply to OVP terminal to RTN as shown in Figure 21. OVP Overvoltage Cut-off response is shown in Figure 22. OVP pin must not be left floating. If OVP pin could be floating due to dry soldering, an additional zener diode at the output will be required for protection from over voltage.

Feature Description (continued)

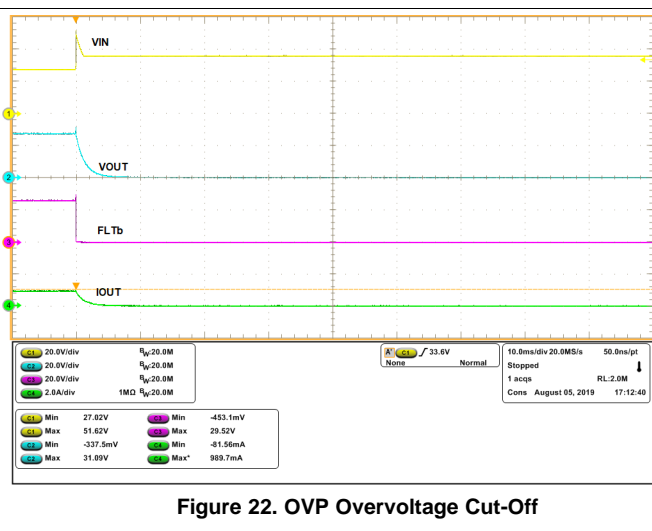
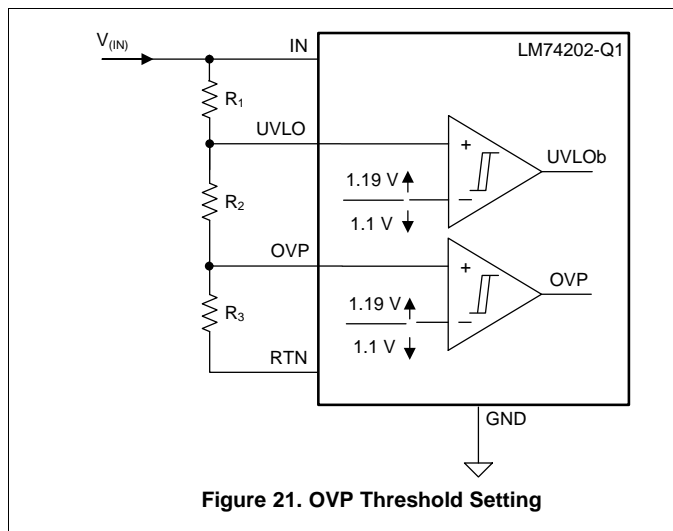

Programmable overvoltage clamp can also be achieved using LM74202-Q1 by connecting the resistor ladder from Vout to OVP to RTN as shown in Figure 23. This results in clamping of output voltage close to OVP set-point by resistors R1 and R2, as shown in Figure 24. This scheme will also help in achieving minimal system Iq during off state. For this OVP configuration, use R1 > 90 kΩ.

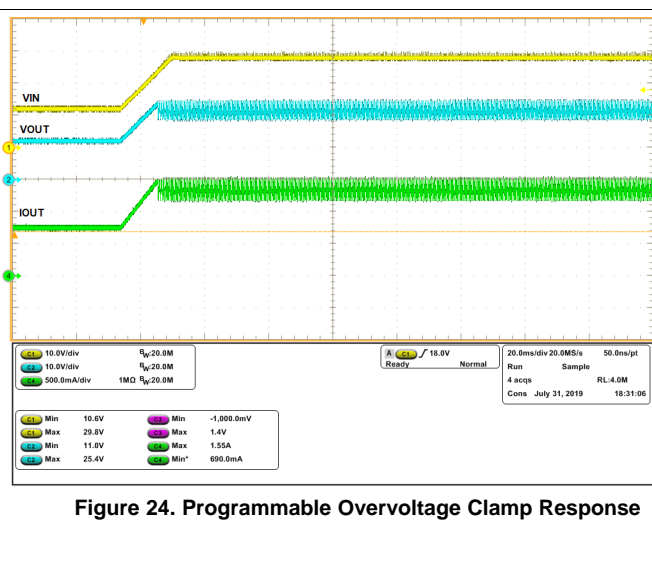
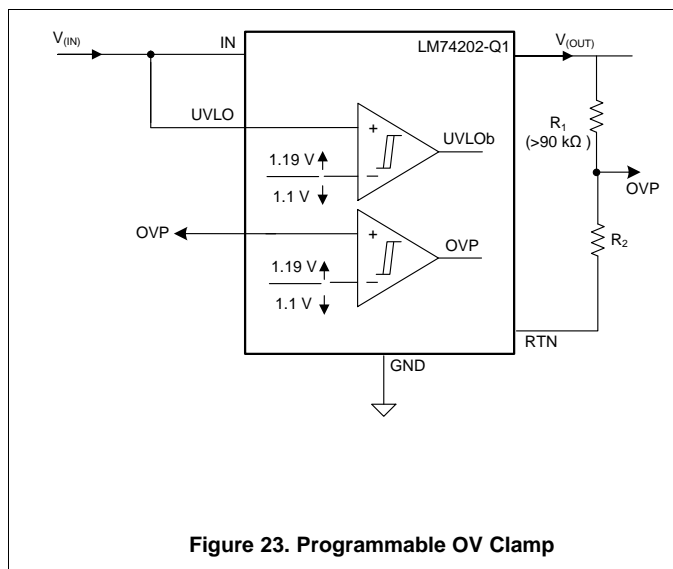

If the OVP pin is connected to GND, the device will clamp the output voltage to 37.5 V (typical).

8.3.3 Reverse Battery Protection

To protect the electronic systems from reverse battery voltage due to miswiring, often a power component like a schottky diode is added in series with the supply line as shown in Figure 25. These additional discretes result in a lossy and bulky protection solution. The LM74202-Q1 devices feature fully integrated reverse input supply protection and does not need an additional diode. These devices can withstand a reverse voltage of -40 V without damage. Figure 26 illustrates the reverse input polarity protection functionality.

Feature Description (continued)

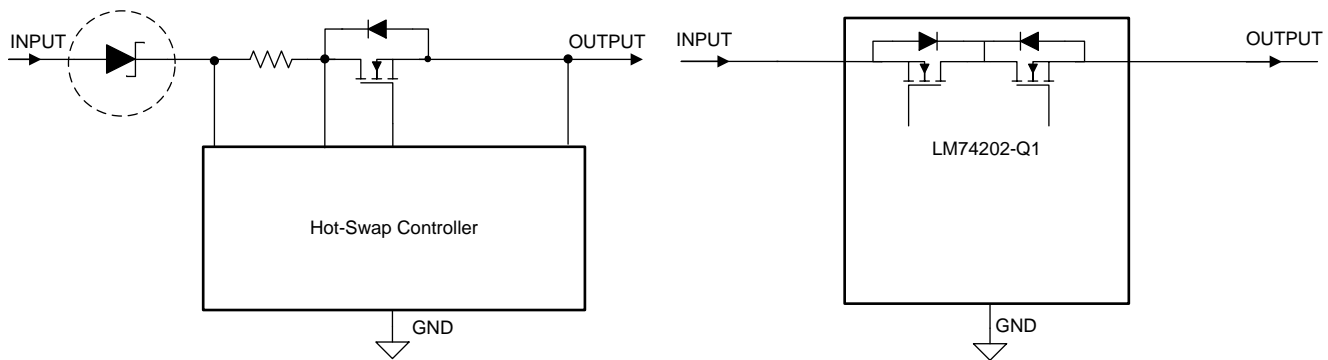

Figure 25. Reverse Battery Protection Circuits - Discrete vs LM74202-Q1

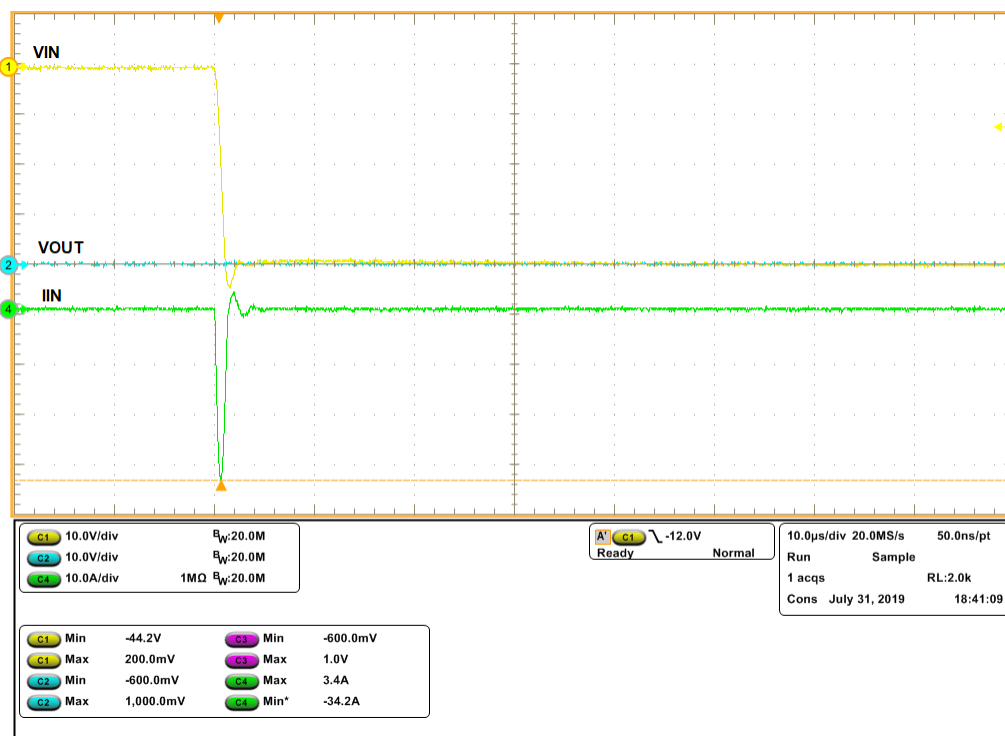

Figure 26. Reverse Input Supply Protection at -40 V

8.3.4 Hot Plug-In and In-Rush Current Control

The device is designed to control the in-rush current upon insertion of a card into a live backplane or other "hot" power source. This limits the voltage sag on the supply voltage and prevents unintended resets of the system power. The controlled start-up also helps to eliminate conductive and radiative interferences. An external capacitor connected from the dVdT pin to RTN defines the slew rate of the output voltage at power-on as shown in Figure 27 and Figure 28.

Feature Description (continued)

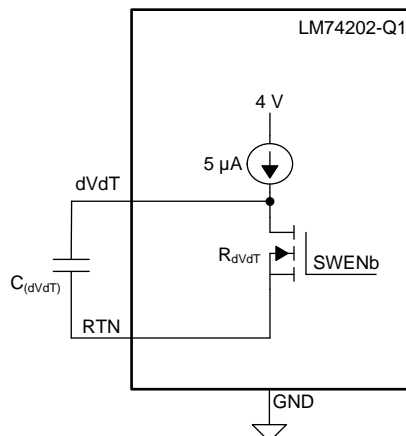

Figure 27. Output Ramp Up Time t_{dVdT} is Set by $C_{(dVdT)}$

The dVdT pin can be left floating to obtain a predetermined slew rate (t_{dVdT}) on the output. When the terminal is left floating, the devices set an internal output voltage ramp rate of 23.9 V / 1.6 ms. A capacitor can be connected from dVdT pin to RTN to program the output voltage slew rate slower than 23.9 V / 1.6 ms. Use [Equation 1](#) and [Equation 2](#) to calculate the external $C_{(dVdT)}$ capacitance.

[Equation 1](#) governs slew rate at start-up.

$$I_{(dVdT)} = \left(\frac{C_{(dVdT)}}{\text{Gain}_{(dVdT)}} \right) \times \left(\frac{dV_{(OUT)}}{dt} \right)$$

where

- $I_{(dVdT)} = 4.7 \mu\text{A}$ (typical)
- $\frac{dV_{(OUT)}}{dt}$
- $\text{Gain}_{(dVdT)} = \text{dVdT to } V_{OUT} \text{ gain} = 24.6$ (1)

The total ramp time (t_{dVdT}) of $V_{(OUT)}$ for 0 to $V_{(IN)}$ can be calculated using [Equation 2](#).

$$t_{dVdT} = 8.7 \times 10^3 \times V_{(IN)} \times C_{(dVdT)} \quad (2)$$

The inrush current can be calculated by [Equation 3](#)

$$I_{INRUSH} = C_{OUT} / [8.7 \times 10^3 \times C_{dVdT}] \quad (3)$$

Feature Description (continued)

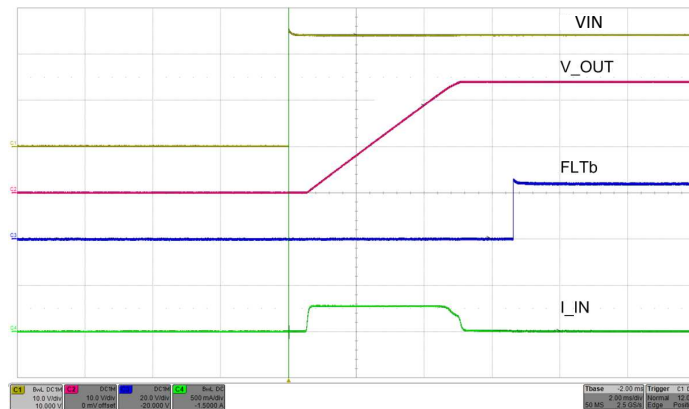

$$C_{dVdT} = 22 \text{ nF} \quad C_{OUT} = 47 \text{ }\mu\text{F} \quad R_{ILIM} = 5.36 \text{ k}\Omega$$

Figure 28. Hot Plug-In and In-Rush Current Control at 24-V Input

8.3.5 Overload and Short Circuit Protection

The device monitors the load current by sensing the voltage across the internal sense resistor. The FET current is monitored during start-up and normal operation.

8.3.5.1 Overload Protection

The device offers following choices for the overload protection fault response:

- Active current limiting (Auto-retry and Latch-off modes)
- Electronic Circuit Breaker with overload timeout (Auto-retry mode)

See the configurations in Table 1 to select a specific overload fault response.

Table 1. Overload Fault Response Configuration

MODE Pin Configuration	Overload Protection Type
Open	Electronic circuit breaker with auto-retry
Shorted to RTN	Active current limiting with auto-retry
A 402-kΩ resistor across MODE pin to RTN pin	Active current limiting with latch-off

8.3.5.1.1 Active Current Limiting

When the active current limiting mode is selected, during overload events, the device continuously regulates the load current to the overcurrent limit $I_{(OL)}$ programmed by the $R_{(ILIM)}$ resistor as shown in Equation 4.

$$I_{OL} = \frac{12}{R_{(ILIM)}}$$

where

- $I_{(OL)}$ is the overload current limit in Ampere
- $R_{(ILIM)}$ is the current limit resistor in kΩ

(4)

During an overload condition, the internal current-limit amplifier regulates the output current to $I_{(LIM)}$. The \overline{FLT} signal asserts after a delay of t_{PGOODF} . The output voltage droops during the current regulation, resulting in increased power dissipation in the device. If the device junction temperature reaches the thermal shutdown threshold ($T_{(TSD)}$), the internal FET is turn off. The device configured in latch-off mode stays latched off until it is reset by either of the following conditions:

- Cycling $V_{(IN)}$ below $V_{(PORF)}$
- Toggling \overline{SHDN}

When the device is configured in auto-retry mode, it commences an auto-retry cycle $t_{CBretry(dly)}$ ms after $T_J < [T_{(TSD)} - 10^\circ\text{C}]$. The \overline{FLT} signal remains asserted until the fault condition is removed and the device resumes normal operation. Figure 29 and Figure 30 illustrates the behavior of the system during current limiting with auto-retry functionality.

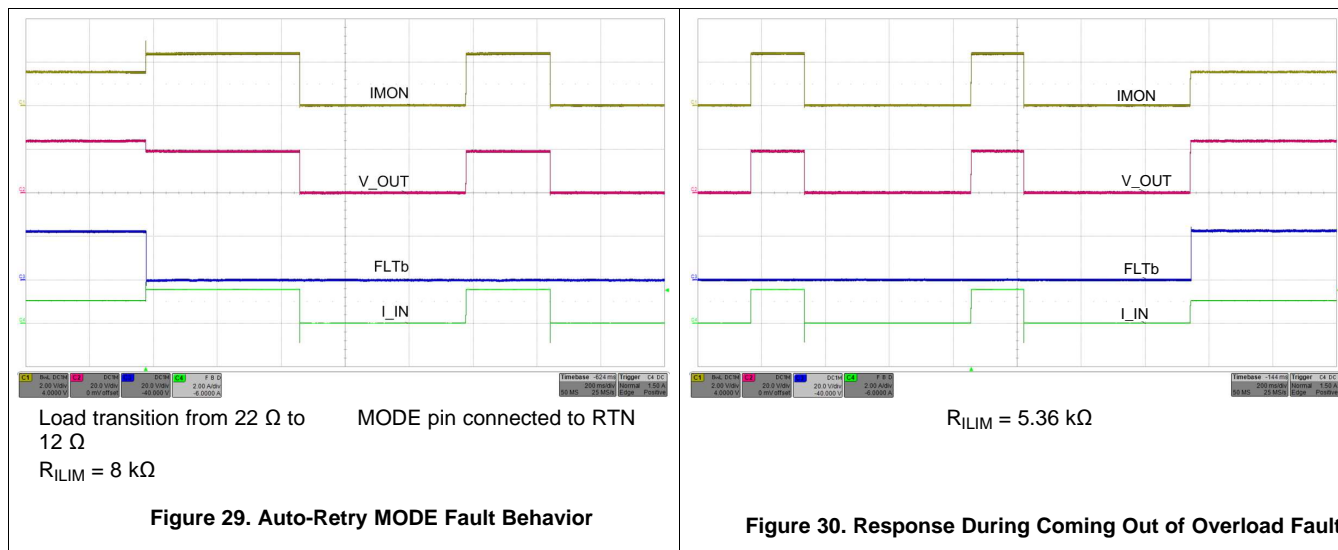

8.3.5.1.2 Electronic Circuit Breaker with Overload Timeout, MODE = OPEN

In this mode, during overload events, the device allows the overload current to flow through the device until $I_{(LOAD)} < I_{(FASTRIP)}$. The circuit breaker threshold $I_{(CB)}$ can be programmed using the $R_{(ILIM)}$ resistor, as shown in Equation 5.

$$I_{(CB)} = \frac{12}{R_{(ILIM)}} + 0.03\text{A}$$

where

- $I_{(CB)}$ is circuit breaker current threshold in A
 - $R_{(ILIM)}$ is the current limit resistor in $k\Omega$
- (5)

The device commences an auto-retry cycle after a delay of $t_{CBretry(dly)}$. The \overline{FLT} signal remains asserted until the fault condition is removed and the device resumes normal operation. Figure 31 and Figure 32 illustrate behavior of the system during electronic circuit breaker with auto-retry functionality.

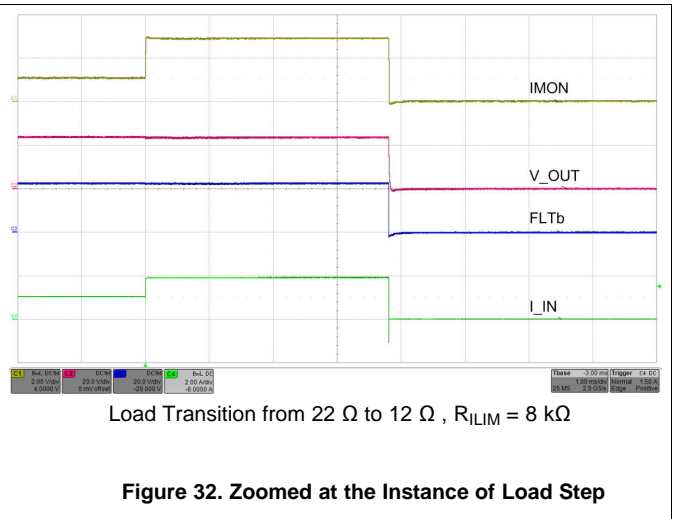
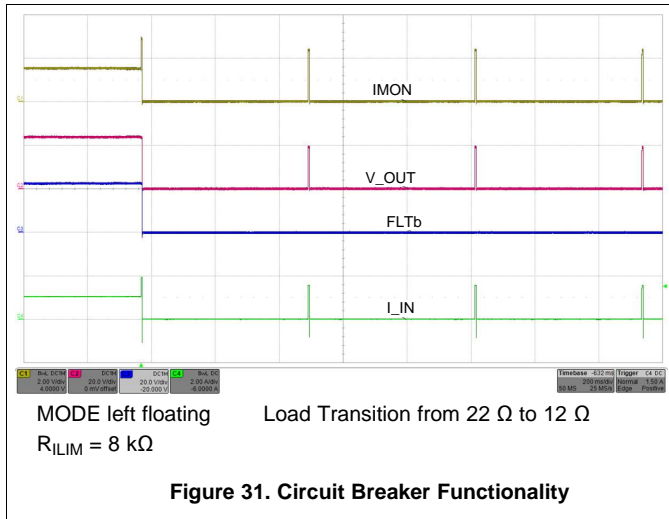

8.3.5.2 Short Circuit Protection

During a transient output short circuit event, the current through the device increases very rapidly. As the current-limit amplifier cannot respond quickly to this event due to its limited bandwidth, the device incorporates a fast-trip comparator, with a threshold $I_{(FASTTRIP)}$. The fast-trip comparator turns off the internal FET after a duration of $t_{FASTTRIP(dly)}$, when the current through the FET exceeds $I_{(FASTTRIP)}$ ($I_{(OUT)} > I_{(FASTTRIP)}$), and terminates the rapid short-circuit peak current. The fast-trip threshold is internally set to 87% higher than the programmed overload current limit ($I_{(FASTTRIP)} = 1.87 \times I_{(OL)} + 0.015$). The fast-trip circuit holds the internal FET off for only a few microseconds, after which the device turns back on slowly, allowing the current-limit loop to regulate the output current to $I_{(OL)}$. Then the device behaves similar to overload condition. [Figure 33](#) and [Figure 34](#) illustrate the behavior of the system when the current exceeds the fast-trip threshold.

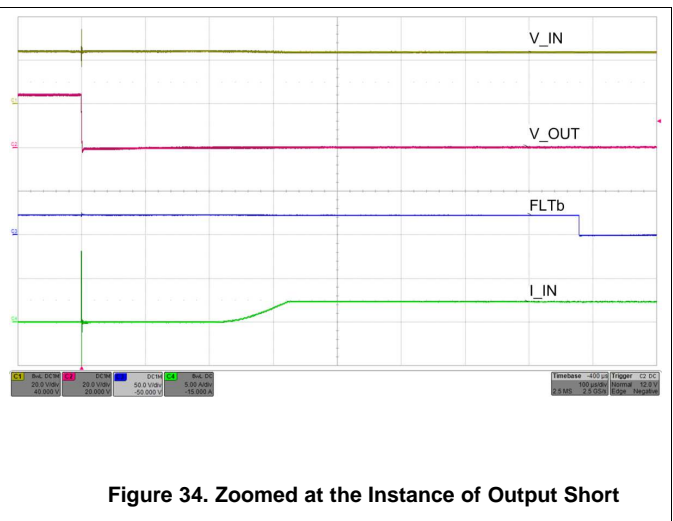
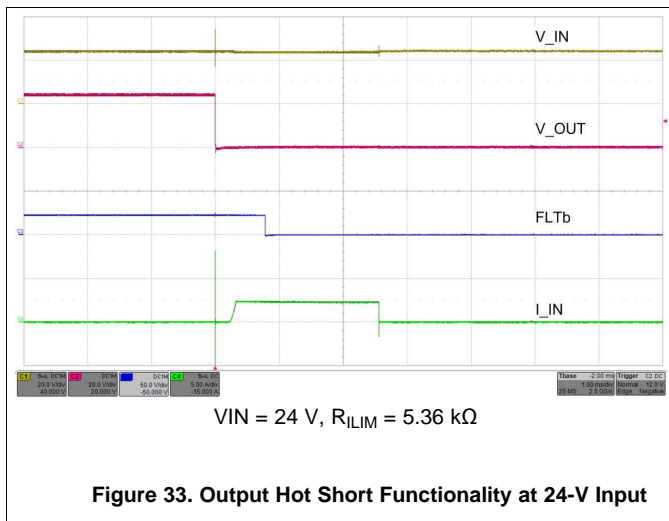

8.3.5.2.1 Start-Up With Short-Circuit On Output

When the device is started with a short-circuit on the output end, it limits the load current to the current limit $I_{(OL)}$, and behaves similarly to the overload condition. Figure 35 illustrates the behavior of the device in this condition. This feature helps in quick isolation of the fault and hence ensures stability of the DC bus.

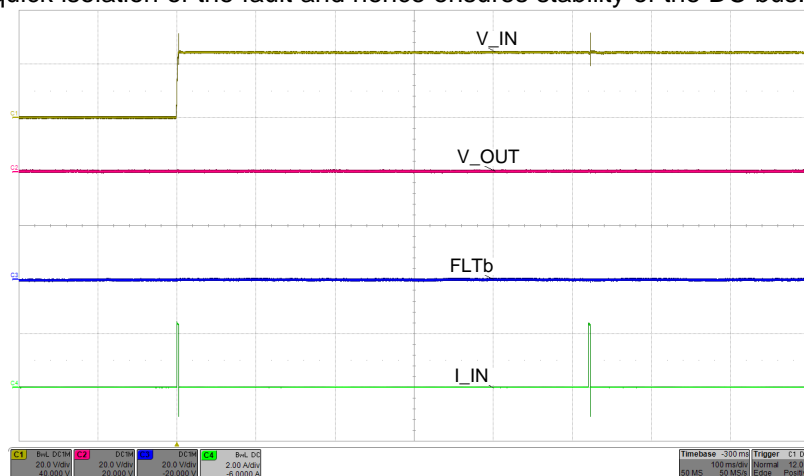

MODE pin connected to RTN
 $V_{IN} = 24\text{ V}$ $R_{ILIM} = 5.36\text{ k}\Omega$
Figure 35. Start-Up With Short on Output

8.3.5.3 FAULT Response

The $\overline{\text{FLT}}$ open-drain output asserts (active low) under following conditions:

- Fault events such as undervoltage, overvoltage, overload, reverse current and thermal shutdown conditions
- When the device enters low current shutdown mode when $\overline{\text{SHDN}}$ is pulled low
- During start-up when the internal FET GATE is not fully enhanced (for example: V_{OUT} has not reached V_{IN}).

The $\overline{\text{FLT}}$ output does not assert in the event of reverse voltage on Input.

The device is designed to eliminate false reporting by using an internal "de-glitch" circuit for fault conditions without the need for an external circuitry.

The $\overline{\text{FLT}}$ signal can also be used as Power Good indicator to the downstream loads like DC-DC converters. An internal Power Good (PGOOD) signal is OR'd with the fault logic. During start-up, when the device is operating in dVdT mode, PGOOD and $\overline{\text{FLT}}$ remains low and is de-asserted after the dVdT mode is completed and the internal FET is fully enhanced and V_{OUT} has reached V_{IN} . The PGOOD signal has deglitch time incorporated to ensure that internal FET is fully enhanced before heavy load is applied by the downstream converters. Rising deglitch delay is determined by $t_{\text{PGOOD(deg)}} = \text{Maximum} \{ (900 + 20 \times C_{(\text{dVdT})}), t_{\text{PGOODR}} \}$, where $C_{(\text{dVdT})}$ is in nF and $t_{\text{PGOOD(deg)}}$ is in μs . $\overline{\text{FLT}}$ can be left open or connected to RTN when not used. $V_{(\text{IN})}$ falling below $V_{(\text{PORF})}$ resets $\overline{\text{FLT}}$.

8.3.5.3.1 Look Ahead Overload Current Fault Indicator

With the device configured in current limit operation and when the overload condition exists for more than t_{PGOODF} , the $\overline{\text{FLT}}$ asserts to warn of impending turnoff of the internal FETs due to the subsequent thermal shutdown event. Figure 36 and Figure 37 depict this behavior. The $\overline{\text{FLT}}$ signal remains asserted until the fault condition is removed and the device resumes normal operation.

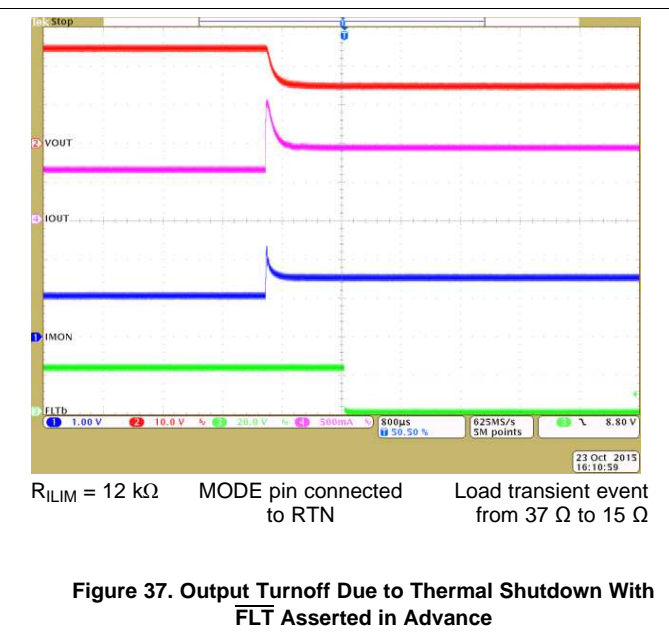
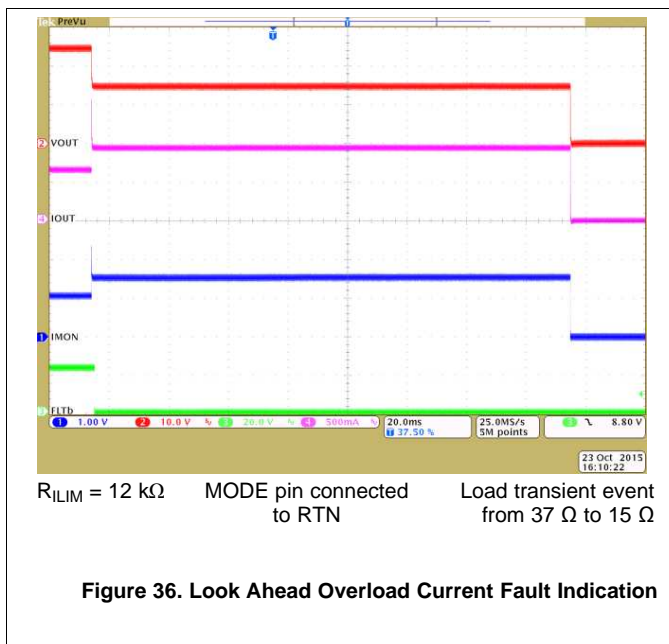

8.3.5.4 Current Monitoring

The current source at IMON terminal is internally configured to be proportional to the current flowing from IN to OUT. This current can be converted into a voltage using a resistor $R_{(\text{IMON})}$ from IMON terminal to RTN terminal. The IMON voltage can be used as a means of monitoring current flow through the system. The maximum voltage range ($V_{(\text{IMONmax})}$) for monitoring the current is limited to minimum of $(V_{(\text{IN})} - 1.5 \text{ V}, 4 \text{ V})$ to ensure linear output. This puts a limitation on maximum value of $R_{(\text{IMON})}$ resistor and is determined by Equation 6.

$$R_{(\text{IMONmax})} = \frac{\text{Min} [(V_{(\text{IN})} - 1.5), 4 \text{ V}]}{1.8 \times I_{(\text{LIM})} \times \text{GAIN}_{(\text{IMON})}} \tag{6}$$

The output voltage at IMON terminal is calculated using [Equation 7](#) and [Equation 8](#).

For $I_{OUT} > 50$ mA,

$$V_{(IMON)} = [I_{(OUT)} \times GAIN_{(IMON)}] \times R_{(IMON)}$$

Where,

- $GAIN_{(IMON)}$ is the gain factor $I_{(IMON)}:I_{(OUT)}$
- $I_{(OUT)}$ is the load current
- $I_{(MON_OS)} = 2$ μ A (Typical) (7)

For $I_{OUT} < 50$ mA (typical), IMON output current is close to $I_{(MON_OS)}$ and [Equation 8](#) provides the voltage output with R_{IMON} .

$$V_{(IMON)} = (I_{(MON_OS)}) \times R_{(IMON)} \tag{8}$$

This pin must not have a bypass capacitor to avoid delay in the current monitoring information.

In case of reverse input polarity fault, an external 100-k Ω resistor is recommended between IMON pin and ADC input to limit the current through the ESD protection structures of the ADC.

8.3.5.5 IN, OUT, RTN and GND Pins

The device has two pins for input (IN) and output (OUT). All IN pins must be connected together and to the power source. A ceramic bypass capacitor close to the device from IN to GND is recommended to alleviate bus transients. The recommended input operating voltage range is 4.2 V to 40 V. Similarly all OUT pins must be connected together and to the load. $V_{(OUT)}$, in the ON condition, is calculated using [Equation 9](#).

$$V_{(OUT)} = V_{(IN)} - (R_{ON} \times I_{(OUT)})$$

Where,

- R_{ON} is the total ON resistance of the internal FETs. (9)

The GND pin must be connected to the system ground. RTN is the device ground reference for all the internal control blocks. Connect the device support components: $R_{(ILIM)}$, $C_{(dVdT)}$, $R_{(IMON)}$, $R_{(MODE)}$ and resistors for UVLO and OVP with respect to the RTN pin. Internally, the device has reverse input polarity protection block between RTN and the GND terminal. Connecting RTN pin to GND pin disables the reverse input polarity protection feature. If negative input voltage is applied on IN pins with RTN pin connected to GND, the device can get damaged.

8.3.5.6 Thermal Shutdown

The device has a built-in overtemperature shutdown circuitry designed to protect the internal FETs, if the junction temperature exceeds $T_{(TSD)}$. After the thermal shutdown event, depending upon the mode of fault response, the device either latches off or commences an auto-retry cycle 540 ms after $T_J < [T_{(TSD)} - 10^\circ\text{C}]$. During the thermal shutdown, the fault pin \overline{FLT} pulls low to indicate a fault condition.

8.3.5.7 Low Current Shutdown Control ($\overline{\text{SHDN}}$)

The internal FETs and hence the load current can be switched off by pulling the $\overline{\text{SHDN}}$ pin below $V_{(\text{SHUTF})}$ threshold with a micro-controller GPIO pin as shown in Figure 38. The device quiescent current reduces to 16 μA (typical) in shutdown state. To assert $\overline{\text{SHDN}}$ low, the pull down must sink at least 10 μA at 400 mV. To enable the device, $\overline{\text{SHDN}}$ must be pulled up to $V_{(\text{SHUTR})}$ threshold. Once the device is enabled, the internal FETs turns on with dVdT mode.

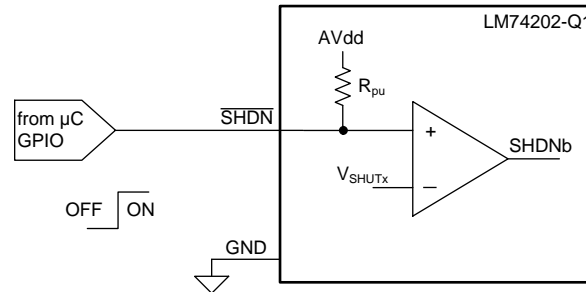

Figure 38. Shutdown Control

8.4 Device Functional Modes

The device responds differently to overload and short circuit conditions. The operational differences are explained in Table 2.

Table 2. Device Operational Differences Under Different MODE Configurations

Mode Pin Configuration	Mode Connected To RTN (Current Limit With Auto-Retry)	A 402-K Ω Resistor Connected Between Mode And RTN Pins (Current Limit With Latchoff)	Mode Pin = Open
Start-up	Inrush current controlled by dVdT		
	Inrush limited to $I_{(\text{OL})}$ level as set by $R_{(\text{ILIM})}$	Inrush limited to $I_{(\text{OL})}$ level as set by $R_{(\text{ILIM})}$	Inrush limited to $I_{(\text{OL})}$ level as set by $R_{(\text{ILIM})}$
			Fault timer runs when current is limited to $I_{(\text{OL})}$
			Fault timer expires after $t_{\text{CB}(\text{dly})}$ causing the FETs to turnoff
	If $T_J > T_{(\text{TSD})}$, device turns off	If $T_J > T_{(\text{TSD})}$, device turns off	Device turns off if $T_J > T_{(\text{TSD})}$ before timer expires
Overcurrent response	Current is limited to $I_{(\text{OL})}$ level as set by $R_{(\text{ILIM})}$	Current is limited to $I_{(\text{OL})}$ level as set by $R_{(\text{ILIM})}$	Current is allowed through the device if $I_{(\text{LOAD})} < I_{(\text{FASTTRIP})}$
	Power dissipation increases as $V_{(\text{IN})} - V_{(\text{OUT})}$ increases	Power dissipation increases as $V_{(\text{IN})} - V_{(\text{OUT})}$ increases	Fault timer runs when the current increases above $I_{(\text{OL})}$
			Fault timer expires after $t_{\text{CB}(\text{dly})}$ causing the FETs to turnoff
	Device turns off when $T_J > T_{(\text{TSD})}$	Device turns off when $T_J > T_{(\text{TSD})}$	Device turns off if $T_J > T_{(\text{TSD})}$ before timer expires
	Device attempts restart 540 ms after $T_J < [T_{(\text{TSD})} - 10^\circ\text{C}]$	Device remains off	Device attempts restart 540 ms after $T_J < [T_{(\text{TSD})} - 10^\circ\text{C}]$.
Short-circuit response	Fast turnoff when $I_{(\text{LOAD})} > I_{(\text{FASTTRIP})}$		
	Quick restart and current limited to $I_{(\text{OL})}$, follows standard start-up		

9 Application and Implementation

NOTE

Information in the following applications sections is not part of the TI component specification, and TI does not warrant its accuracy or completeness. TI's customers are responsible for determining suitability of components for their purposes. Customers should validate and test their design implementation to confirm system functionality.

9.1 Application Information

The device is an automotive ideal diode, typically used for load protection in automotive applications. It can operate from 12-V battery with programmable current limit, overvoltage, undervoltage and reverse polarity protections. The device provides robust protection against reverse current and transients (such as ISO 7637-2 Pulse 1 and ISO 16750-2 Pulse 5b) due to cables and switches in different automotive systems such as an ECU. The device also provides robust protection for output short to battery, output short to GND, reverse battery and input overvoltage.

The [Detailed Design Procedure](#) section can be used to select component values for the device.

9.2 Typical Application

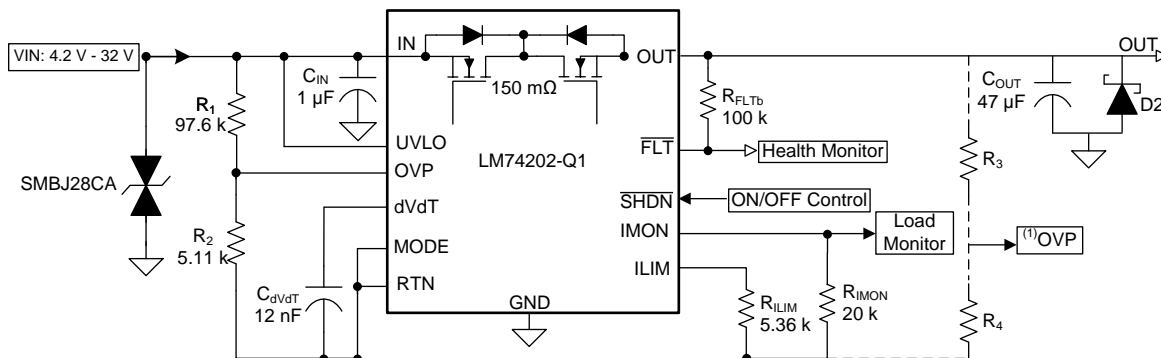

(1) OVP connection for Programmable over voltage clamp. See [Overvoltage Protection \(OVP\)](#).

Figure 39. 12-V, 2-A Ideal Diode Load Protection Circuit for Automotive ECU

9.2.1 Design Requirements

Table 3 shows the Design Requirements for LM74202-Q1. In addition to below requirements, the circuit is designed to provide protection for transients as per ISO 7637-2 Pulse 1 and ISO 16750-2 Pulse 5b.

Table 3. Design Requirements

DESIGN PARAMETER		EXAMPLE VALUE
$V_{(IN)}$	Typical input voltage	4.2 to 32 V
$V_{(UV)}$	Undervoltage lockout set point	4 V
$V_{(OV)}$	Overvoltage cutoff set point	24 V
$I_{(LIM)}$	Current limit	2.23 A
$C_{(OUT)}$	Load capacitance	47 μ F
$I_{(LOAD)}$	Load current	2 A

9.2.2 Detailed Design Procedure

9.2.2.1 Step by Step Design Procedure

To begin the design process, the designer must know the following parameters:

- Operating voltage range

- Maximum output capacitance
- Start-up time
- Maximum current limit
- Transient voltage levels

9.2.2.2 Setting Undervoltage Lockout and Overvoltage Set Point for Operating Voltage Range

To provide operation in cold crank conditions for automotive batteries, the UVLO is set to POR value (4 V) by connecting UVLO to IN pin and OVP threshold is set from resistors connected from IN pins to provide protection from transient during ISO 16750 Pulse 5b. During the ISO 16750 5b transient, output voltage is cut-off at 24 V and provides protection to load from high input voltage during the transient. The overvoltage threshold is calculated by Equation 10.

$$V_{OVPR} = R_2 / (R_1 + R_2) \times V_{OV}$$

where

- Overvoltage threshold rising, $V_{OVPR} = 1.19 \text{ V}$
- V_{OV} is overvoltage protection voltage (= 24 V) (10)

However, the leakage current due to external active components connected at resistor string can add error to these calculations. So, the resistor string current, $I(R_{23})$ must be chosen to be 20x greater than the leakage current of OVP pin.

9.2.2.3 Programming the Current-Limit Threshold— $R_{(ILIM)}$ Selection

The $R_{(ILIM)}$ resistor at the ILIM pin sets the over load current limit, this can be set using Equation 4.

$$R_{(ILIM)} = 5.36 \text{ k}\Omega \text{ was selected to set } I_{LIM} \text{ to } 2.23 \text{ A.}$$

9.2.2.4 Programming Current Monitoring Resistor— R_{IMON}

The voltage at IMON pin $V_{(IMON)}$ represents the voltage proportional to the load current. This can be connected to an ADC of the downstream system for health monitoring of the system. The $R_{(IMON)}$ must be configured based on the maximum input voltage range of the ADC used. $R_{(IMON)}$ is set using Equation 11.

$$R_{(IMON)} = \frac{V_{(IMONmax)}}{I_{(LIM)} \times 75 \times 10^{-6}} \tag{11}$$

For current monitoring up-to a current of 2.2 A, and considering the operating input voltage range of ADC from 0 V to 4 V, $V_{(IMONmax)}$ is 4 V and $R_{(IMON)}$ is selected as 20 k Ω .

9.2.2.5 Limiting the Inrush Current

To limit the inrush current and power dissipation during start-up, an appropriate value of C_{dVdT} must be selected. The inrush current during start-up is estimated by Equation 12. A 12nF capacitance is selected for C_{dVdT} to keep inrush current less than 0.5 A.

$$I_{INRUSH} = C_{OUT} / [8.7 \times 10^3 \times C_{dVdT}] \tag{12}$$

9.2.2.5.1 Selection of Input TVS for Transient Protection

To protect the device and the load from input transients exceeding the absolute maximum ratings of the device, a TVS diode is required at input of the device. To meet the requirements of protection for ISO 16750 pulse 5b and ISO 7637 pulse 1 as per Table 4, SMBJ28CA is selected for protection from transients.

Table 4. Input TVS Selection for Transients

Parameter	ISO 16750 Pulse 5b	ISO 7637 Pulse 1 and Reverse Battery	
Maximum Transient Voltage of Pulse (V_T)	35 V	-150V	A bidirectional TVS is required to protect from positive and negative transients
Pulse Current through TVS (I_{Pulse})	$(V_T - V_C) / (R_i)$	$(V_T - V_C) / (R_i)$	R_i = Source impedance. For ISO 16750 Pulse 5b; $R_i = 0.5 \Omega$ For ISO 7637 Pulse 1; $R_i = 10 \Omega$

Table 4. Input TVS Selection for Transients (continued)

Parameter	ISO 16750 Pulse 5b	ISO 7637 Pulse 1 and Reverse Battery	
Clamping voltage of TVS (V_C) at Pulse current I_{Pulse}	< 55 V	> $-(55 - V_{OUT-Max})$ V	To keep input voltage below absolute maximum rating of the device. See Equation 13 for V_C
Breakdown voltage of TVS (V_{BR})	> 32V	> 14V	To operate with maximum operating input voltage and to protect from maximum reverse battery voltage

$$V_C = V_{BR} + I_{Pulse} \times [V_{Clamp-max} - V_{BR}] / [I_{PP} - I_T]$$

where

- V_C is the clamping voltage of TVS at I_{Pulse} current through it.
- V_{BR} is break down voltage of TVS with I_T test current through it.
- $V_{Clamp-max}$ is maximum clamping voltage of TVS at peak pulse current I_{PP}
- V_{BR} , I_T , $V_{Clamp-max}$ and I_{PP} are the specifications of the TVS diode.

(13)

9.2.3 Application Curves

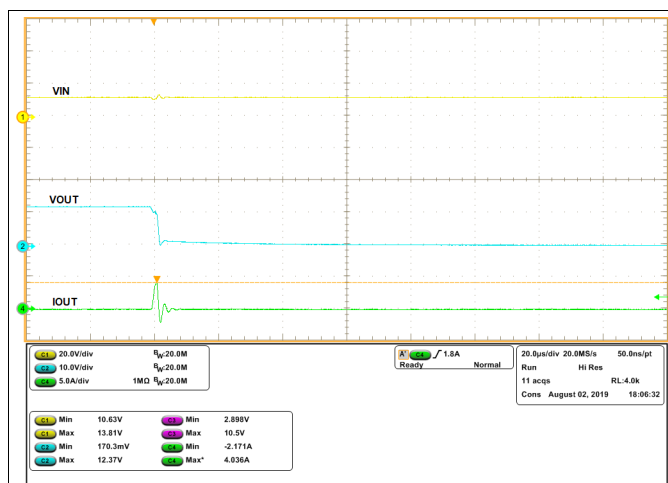

Figure 40. Protection from Output Short to GND [$V_{IN} = 12$ V, $I_{LIM} = 2.23$ A, $MODE = RTN$]

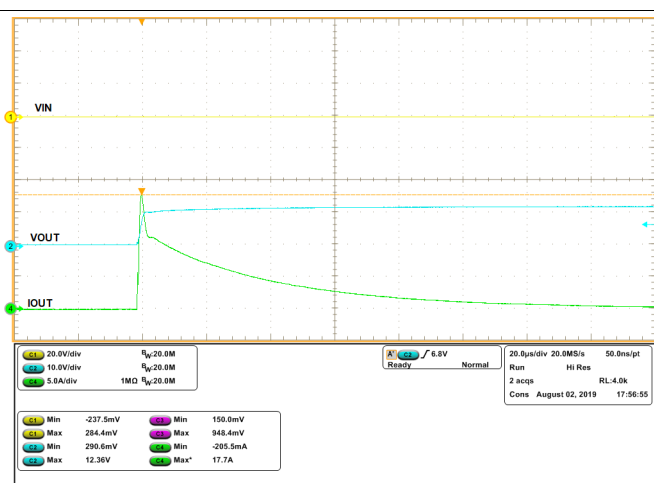

Figure 41. Protection from Output short to Battery [$V_{IN} =$ Floating, $V_{OUT} = 12$ V, $I_{LIM} = 2.23$ A, $MODE = RTN$]

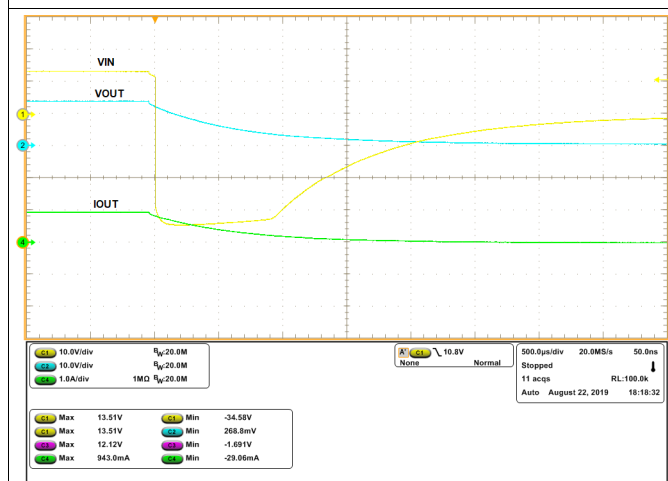

Figure 42. Protection from ISO 7637-2 Pulse 1 [12 V Battery, Transient Voltage = -150 V, $R_{LOAD} = 14 \Omega$]

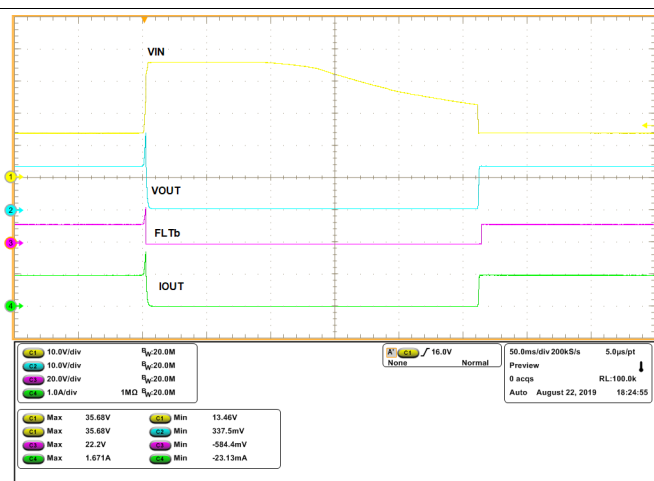

Figure 43. Protection from ISO 16750-2 Pulse 5b [12 V Battery, Transient Voltage = 35 V, $R_{LOAD} = 14 \Omega$]

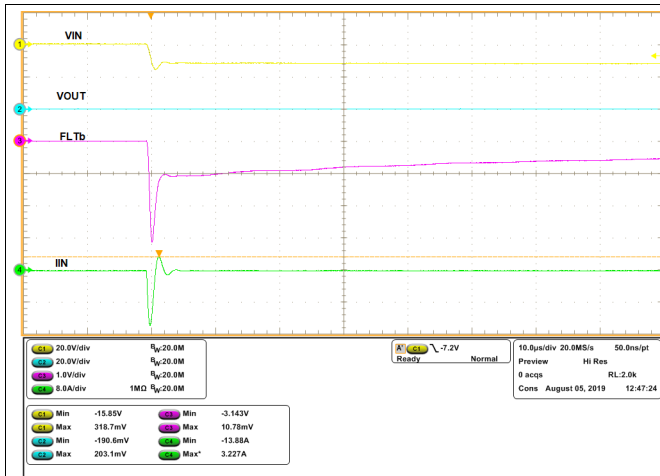

Figure 44. Protection from Reverse Battery [$V_{IN} = -12\text{ V}$, $V_{OUT} = 0\text{ V}$, $I_{LIM} = 2.23\text{ A}$]

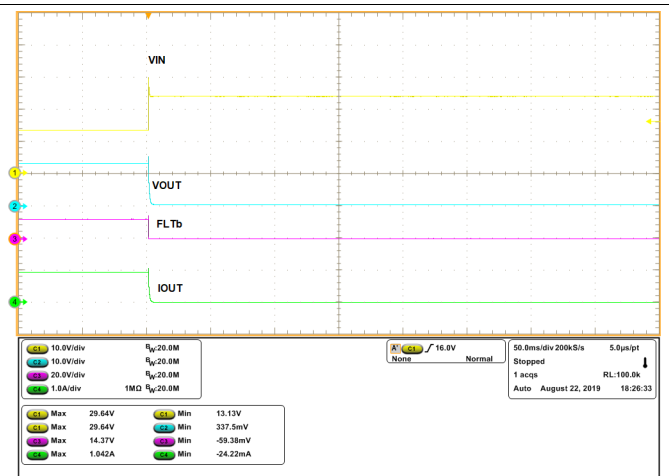

Figure 45. Protection from overvoltage at Input [$V_{IN} = 36\text{ V}$, $R_{LOAD} = 14\ \Omega$, $I_{LIM} = 2.23\text{ A}$]

10 Power Supply Recommendations

The device is designed for the supply voltage range of $4.2\text{ V} \leq V_{\text{IN}} \leq 40\text{ V}$. Power supply must be rated higher than the current limit set to avoid voltage droops during overcurrent and short circuit conditions.

10.1 Transient Protection

In case of short circuit and over load current limit, when the device interrupts current flow, input inductance generates a positive voltage spike on the input and output inductance generates a negative voltage spike on the output. The peak amplitude of voltage spikes (transients) is dependent on value of inductance in series to the input or output of the device. Such transients can exceed the *Absolute Maximum Ratings* of the device if steps are not taken to address the issue.

Typical methods for addressing transients include:

- Minimizing lead length and inductance into and out of the device
- Using large PCB GND plane
- Schottky diode across the output to absorb negative spikes
- A ceramic capacitor at input (C_{IN}) with value more than $1\mu\text{F}$ to absorb the energy and dampen the transients.

The approximate value of input capacitance can be estimated with [Equation 14](#).

$$V_{\text{spike(Absolute)}} = V_{\text{(IN)}} + I_{\text{(Load)}} \times \sqrt{\frac{L_{\text{(IN)}}}{C_{\text{(IN)}}}}$$

where

- $V_{\text{(IN)}}$ is the nominal supply voltage
- $I_{\text{(LOAD)}}$ is the load current
- $L_{\text{(IN)}}$ equals the effective inductance seen looking into the source
- $C_{\text{(IN)}}$ is the capacitance present at the input

(14)

Automotive applications could require additional Transient Voltage Suppressor (TVS) to prevent transients from exceeding the *Absolute Maximum Ratings* of the device. These transients include ISO 7637 Pulse 1, Output short to battery, Output short to GND and reverse battery at input.

The circuit implementation with optional protection components (TVS Diode at Input and schottky diode at output) is shown in [Figure 46](#). For protection from automotive transients similar to ISO 7637 Pulse 1, Output short to battery, output short to GND and reverse battery, use $C_{\text{IN}} \geq 1\mu\text{F}$ and $C_{\text{OUT}} \geq 3.3\mu\text{F}$. For selection of TVS diode and other components, see [Application Information](#).

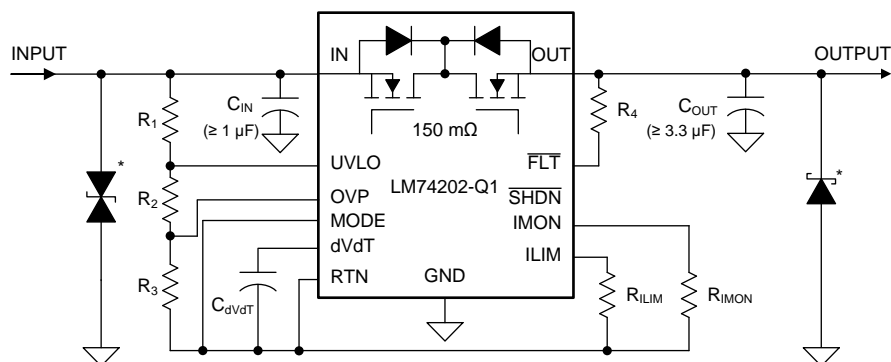

* Optional components needed for suppression of transients

Figure 46. Circuit Implementation for Automotive Transient Protection

11 Layout

11.1 Layout Guidelines

- For all the applications, a 0.1 μF or higher value ceramic decoupling capacitor is recommended between IN terminal and GND. Use $C_{\text{IN}} \geq 1 \mu\text{F}$ for automotive transient protection. See [Transient Protection](#).
- The optimum placement of decoupling capacitor is closest to the IN and GND terminals of the device. Care must be taken to minimize the loop area formed by the bypass-capacitor connection, the IN terminal, and the GND terminal of the device. See [Figure 47](#) for PCB layout example with HTSSOP package.
- High current carrying power path connections must be as short as possible and must be sized to carry at least twice the full-load current.
- RTN, which is the reference ground for the device must be a copper plane or island.
- Locate all the device support components $R_{(\text{ILIM})}$, $C_{(\text{dVdT})}$, $R_{(\text{IMON})}$, and MODE, UVLO, OVP resistors close to their connection pin. Connect the other end of the component to the RTN with shortest trace length.
- The trace routing for the $R_{(\text{ILIM})}$ and $R_{(\text{IMON})}$ components to the device must be as short as possible to reduce parasitic effects on the current limit and current monitoring accuracy. These traces must not have any coupling to switching signals on the board.
- Protection devices such as TVS, snubbers, capacitors, or diodes must be placed physically close to the device they are intended to protect, and routed with short traces to reduce inductance. For example, a protection Schottky diode is recommended to address negative transients due to switching of inductive loads, and it must be physically close to the OUT and GND pins.
- Thermal Considerations: When properly mounted, the PowerPAD package provides significantly greater cooling ability. To operate at rated power, the PowerPAD must be soldered directly to the board RTN plane directly under the device. Other planes, such as the bottom side of the circuit board can be used to increase heat sinking in higher current applications. Designs that do not need reverse input polarity protection can have RTN, GND and PowerPAD connected together. PowerPAD in these designs can be connected to the PCB ground plane.

11.2 Layout Example

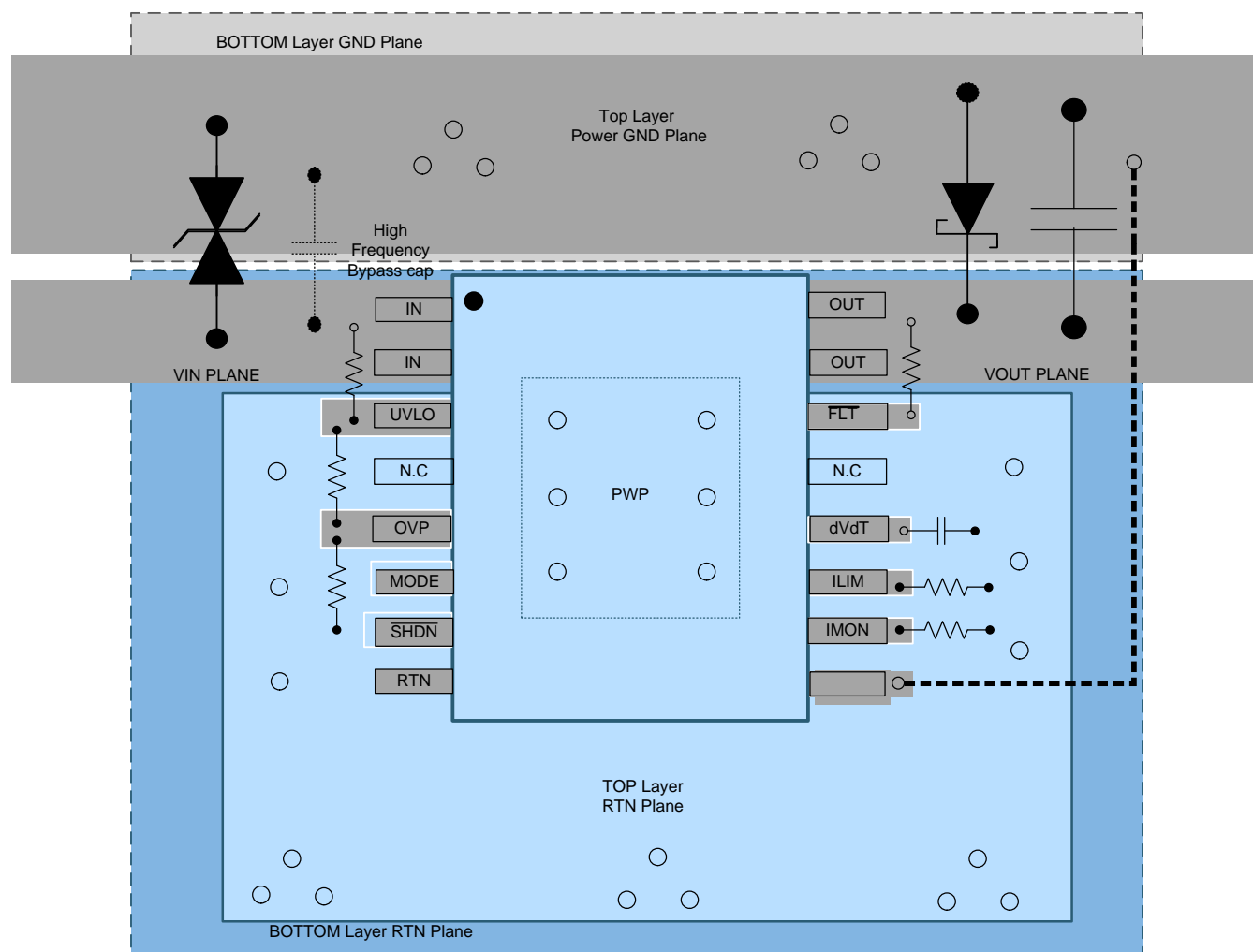

Figure 47. Typical PCB Layout Example With HTSSOP Package With a 2-Layer PCB

12 Device and Documentation Support

12.1 Documentation Support

12.1.1 Related Documentation

For related documentation see the following:

- [LM76202-Q1 EVM User's Guide](#)

12.2 Receiving Notification of Documentation Updates

To receive notification of documentation updates, navigate to the device product folder on ti.com. In the upper right corner, click on *Alert me* to register and receive a weekly digest of any product information that has changed. For change details, review the revision history included in any revised document.

12.3 Community Resources

TI E2E™ support forums are an engineer's go-to source for fast, verified answers and design help — straight from the experts. Search existing answers or ask your own question to get the quick design help you need.

Linked content is provided "AS IS" by the respective contributors. They do not constitute TI specifications and do not necessarily reflect TI's views; see TI's [Terms of Use](#).

12.4 Trademarks

E2E is a trademark of Texas Instruments.

All other trademarks are the property of their respective owners.

12.5 Electrostatic Discharge Caution



This integrated circuit can be damaged by ESD. Texas Instruments recommends that all integrated circuits be handled with appropriate precautions. Failure to observe proper handling and installation procedures can cause damage.

ESD damage can range from subtle performance degradation to complete device failure. Precision integrated circuits may be more susceptible to damage because very small parametric changes could cause the device not to meet its published specifications.

12.6 Glossary

[SLYZ022](#) — *TI Glossary*.

This glossary lists and explains terms, acronyms, and definitions.

13 Mechanical, Packaging, and Orderable Information

The following pages include mechanical, packaging, and orderable information. This information is the most current data available for the designated devices. This data is subject to change without notice and revision of this document. For browser-based versions of this data sheet, refer to the left-hand navigation.

PACKAGING INFORMATION

Orderable Device	Status (1)	Package Type	Package Drawing	Pins	Package Qty	Eco Plan (2)	Lead finish/ Ball material (6)	MSL Peak Temp (3)	Op Temp (°C)	Device Marking (4/5)	Samples
LM74202QPWPRQ1	ACTIVE	HTSSOP	PWP	16	2000	RoHS & Green	NIPDAU	Level-3-260C-168 HR	-40 to 125	M74202Q	Samples

(1) The marketing status values are defined as follows:

ACTIVE: Product device recommended for new designs.

LIFEBUY: TI has announced that the device will be discontinued, and a lifetime-buy period is in effect.

NRND: Not recommended for new designs. Device is in production to support existing customers, but TI does not recommend using this part in a new design.

PREVIEW: Device has been announced but is not in production. Samples may or may not be available.

OBSOLETE: TI has discontinued the production of the device.

(2) **RoHS:** TI defines "RoHS" to mean semiconductor products that are compliant with the current EU RoHS requirements for all 10 RoHS substances, including the requirement that RoHS substance do not exceed 0.1% by weight in homogeneous materials. Where designed to be soldered at high temperatures, "RoHS" products are suitable for use in specified lead-free processes. TI may reference these types of products as "Pb-Free".

RoHS Exempt: TI defines "RoHS Exempt" to mean products that contain lead but are compliant with EU RoHS pursuant to a specific EU RoHS exemption.

Green: TI defines "Green" to mean the content of Chlorine (Cl) and Bromine (Br) based flame retardants meet JS709B low halogen requirements of <=1000ppm threshold. Antimony trioxide based flame retardants must also meet the <=1000ppm threshold requirement.

(3) MSL, Peak Temp. - The Moisture Sensitivity Level rating according to the JEDEC industry standard classifications, and peak solder temperature.

(4) There may be additional marking, which relates to the logo, the lot trace code information, or the environmental category on the device.

(5) Multiple Device Markings will be inside parentheses. Only one Device Marking contained in parentheses and separated by a "-" will appear on a device. If a line is indented then it is a continuation of the previous line and the two combined represent the entire Device Marking for that device.

(6) Lead finish/Ball material - Orderable Devices may have multiple material finish options. Finish options are separated by a vertical ruled line. Lead finish/Ball material values may wrap to two lines if the finish value exceeds the maximum column width.

Important Information and Disclaimer: The information provided on this page represents TI's knowledge and belief as of the date that it is provided. TI bases its knowledge and belief on information provided by third parties, and makes no representation or warranty as to the accuracy of such information. Efforts are underway to better integrate information from third parties. TI has taken and continues to take reasonable steps to provide representative and accurate information but may not have conducted destructive testing or chemical analysis on incoming materials and chemicals. TI and TI suppliers consider certain information to be proprietary, and thus CAS numbers and other limited information may not be available for release.

In no event shall TI's liability arising out of such information exceed the total purchase price of the TI part(s) at issue in this document sold by TI to Customer on an annual basis.

TAPE AND REEL INFORMATION

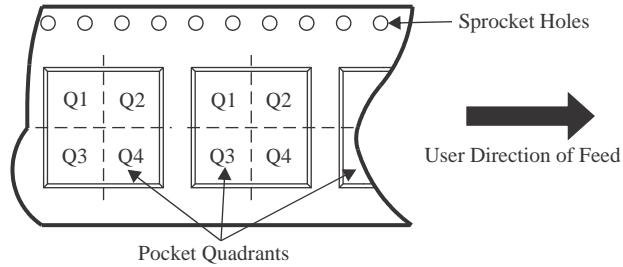
QUADRANT ASSIGNMENTS FOR PIN 1 ORIENTATION IN TAPE

*All dimensions are nominal

Device	Package Type	Package Drawing	Pins	SPQ	Reel Diameter (mm)	Reel Width W1 (mm)	A0 (mm)	B0 (mm)	K0 (mm)	P1 (mm)	W (mm)	Pin1 Quadrant
LM74202QPWPRQ1	HTSSOP	PWP	16	2000	330.0	12.4	6.9	5.6	1.6	8.0	12.0	Q1

TAPE AND REEL BOX DIMENSIONS

*All dimensions are nominal

Device	Package Type	Package Drawing	Pins	SPQ	Length (mm)	Width (mm)	Height (mm)
LM74202QPWPRQ1	HTSSOP	PWP	16	2000	350.0	350.0	43.0

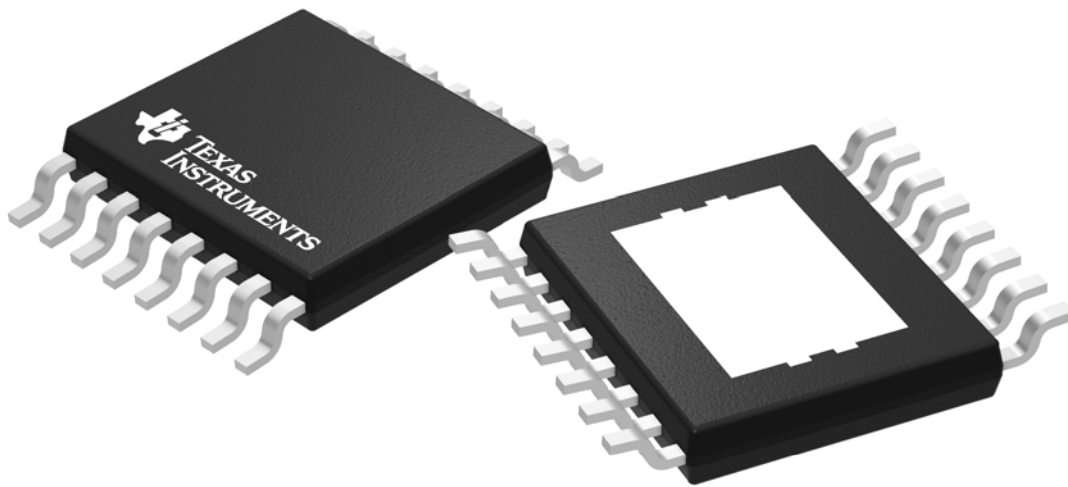

Images above are just a representation of the package family, actual package may vary.
Refer to the product data sheet for package details.

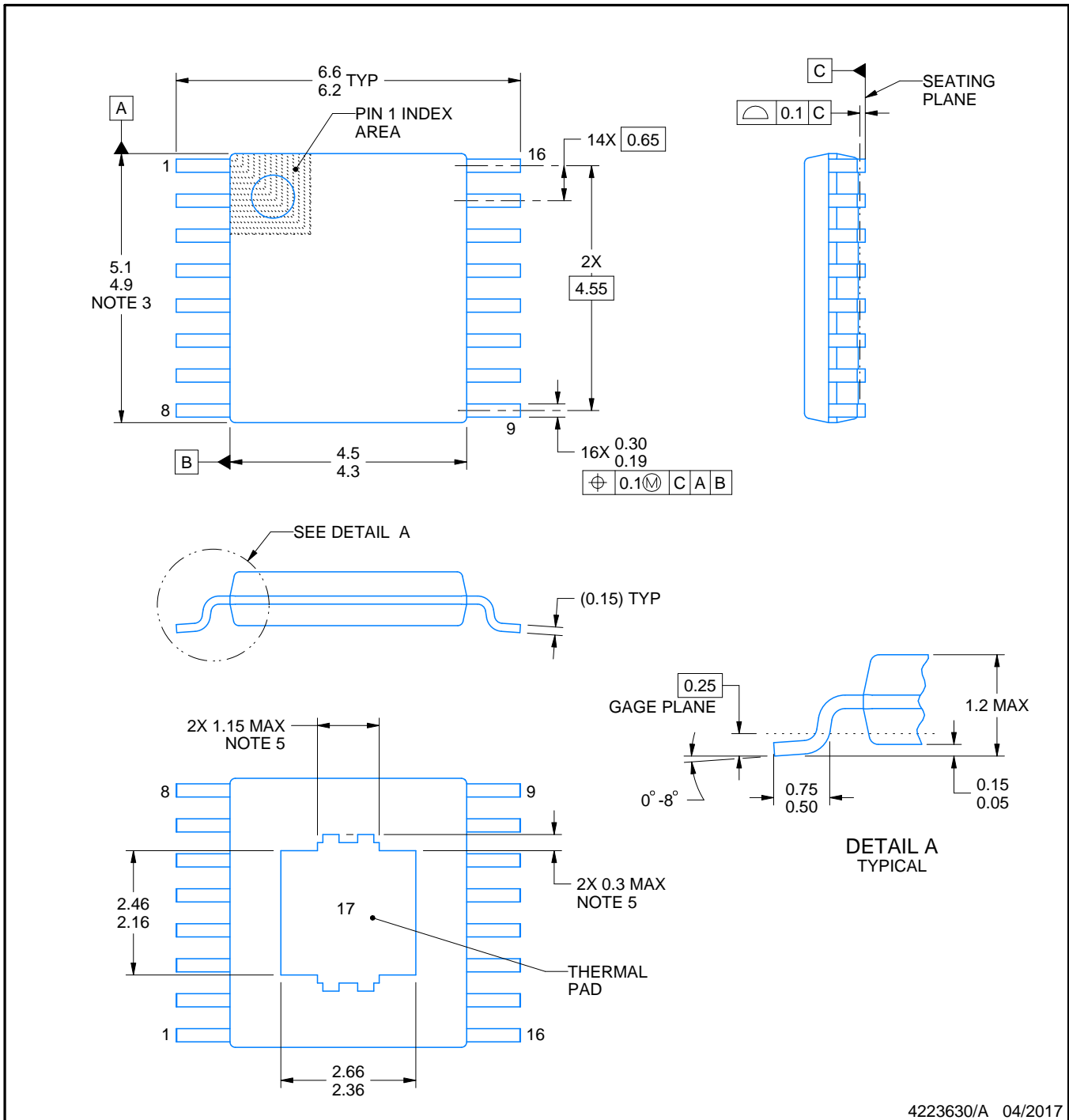
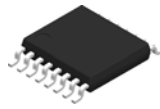

4223630/A 04/2017

NOTES:

PowerPAD is a trademark of Texas Instruments.

1. All linear dimensions are in millimeters. Any dimensions in parenthesis are for reference only. Dimensioning and tolerancing per ASME Y14.5M.
2. This drawing is subject to change without notice.
3. This dimension does not include mold flash, protrusions, or gate burrs. Mold flash, protrusions, or gate burrs shall not exceed 0.15 mm per side.
4. Reference JEDEC registration MO-153.
5. Features may differ or may not be present.

EXAMPLE BOARD LAYOUT

PWP0016H

PowerPAD™ TSSOP - 1.2 mm max height

SMALL OUTLINE PACKAGE

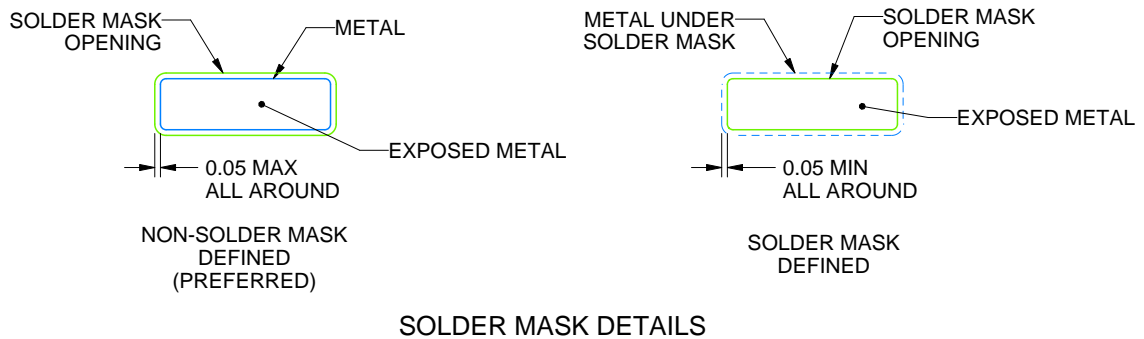
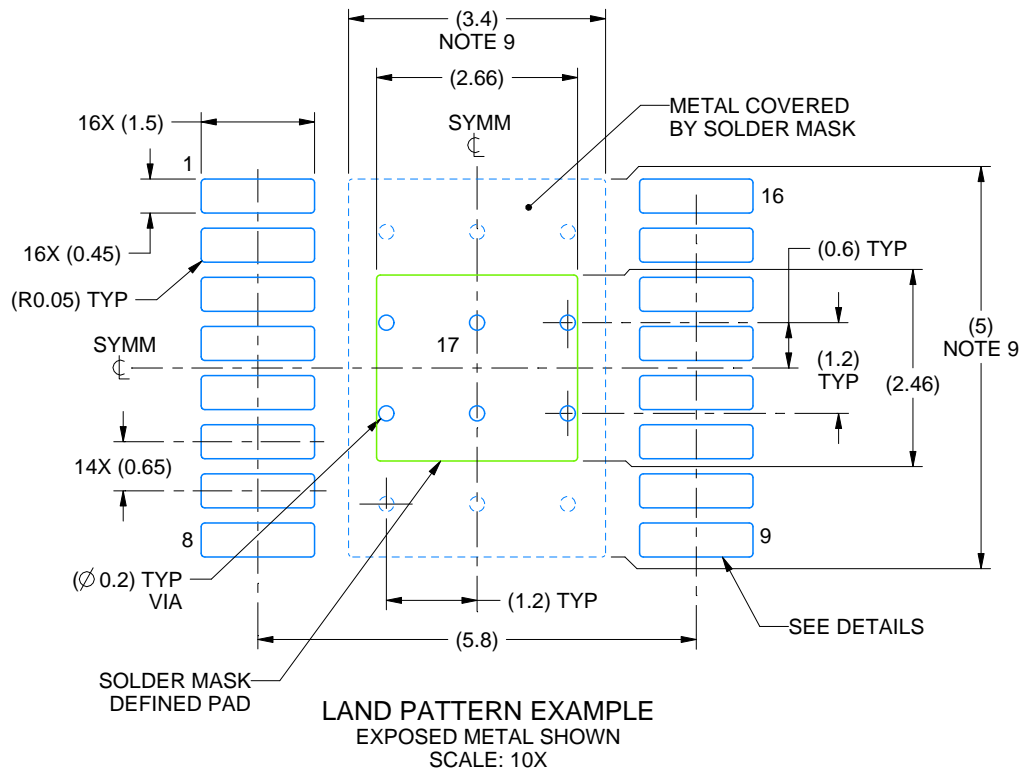

4223630/A 04/2017

NOTES: (continued)

6. Publication IPC-7351 may have alternate designs.
7. Solder mask tolerances between and around signal pads can vary based on board fabrication site.
8. This package is designed to be soldered to a thermal pad on the board. For more information, see Texas Instruments literature numbers SLMA002 (www.ti.com/lit/slma002) and SLMA004 (www.ti.com/lit/slma004).
9. Size of metal pad may vary due to creepage requirement.
10. Vias are optional depending on application, refer to device data sheet. It is recommended that vias under paste be filled, plugged or tented.

EXAMPLE STENCIL DESIGN

PWP0016H

PowerPAD™ TSSOP - 1.2 mm max height

SMALL OUTLINE PACKAGE

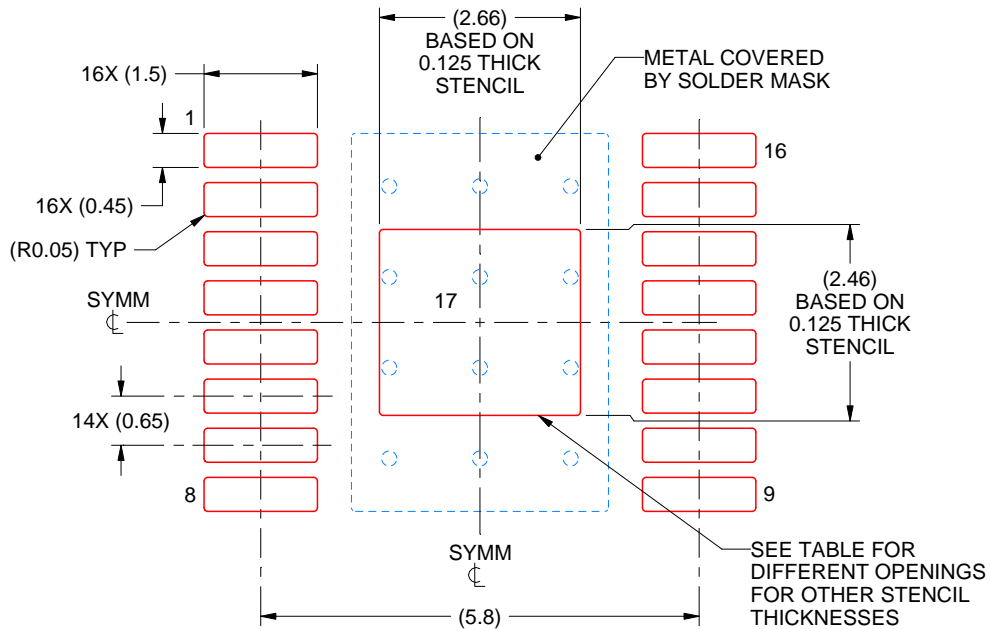

SOLDER PASTE EXAMPLE
 BASED ON 0.125 mm THICK STENCIL
 SCALE: 10X

STENCIL THICKNESS	SOLDER STENCIL OPENING
0.1	2.97 X 2.75
0.125	2.66 X 2.46 (SHOWN)
0.15	2.43 X 2.25
0.175	2.25 X 2.08

4223630/A 04/2017

NOTES: (continued)

11. Laser cutting apertures with trapezoidal walls and rounded corners may offer better paste release. IPC-7525 may have alternate design recommendations.
12. Board assembly site may have different recommendations for stencil design.

IMPORTANT NOTICE AND DISCLAIMER

TI PROVIDES TECHNICAL AND RELIABILITY DATA (INCLUDING DATA SHEETS), DESIGN RESOURCES (INCLUDING REFERENCE DESIGNS), APPLICATION OR OTHER DESIGN ADVICE, WEB TOOLS, SAFETY INFORMATION, AND OTHER RESOURCES "AS IS" AND WITH ALL FAULTS, AND DISCLAIMS ALL WARRANTIES, EXPRESS AND IMPLIED, INCLUDING WITHOUT LIMITATION ANY IMPLIED WARRANTIES OF MERCHANTABILITY, FITNESS FOR A PARTICULAR PURPOSE OR NON-INFRINGEMENT OF THIRD PARTY INTELLECTUAL PROPERTY RIGHTS.

These resources are intended for skilled developers designing with TI products. You are solely responsible for (1) selecting the appropriate TI products for your application, (2) designing, validating and testing your application, and (3) ensuring your application meets applicable standards, and any other safety, security, regulatory or other requirements.

These resources are subject to change without notice. TI grants you permission to use these resources only for development of an application that uses the TI products described in the resource. Other reproduction and display of these resources is prohibited. No license is granted to any other TI intellectual property right or to any third party intellectual property right. TI disclaims responsibility for, and you will fully indemnify TI and its representatives against, any claims, damages, costs, losses, and liabilities arising out of your use of these resources.

TI's products are provided subject to [TI's Terms of Sale](#) or other applicable terms available either on [ti.com](https://www.ti.com) or provided in conjunction with such TI products. TI's provision of these resources does not expand or otherwise alter TI's applicable warranties or warranty disclaimers for TI products.

TI objects to and rejects any additional or different terms you may have proposed.

Mailing Address: Texas Instruments, Post Office Box 655303, Dallas, Texas 75265
Copyright © 2023, Texas Instruments Incorporated