

LMC603x 2.7V, Low-Power, Single-Supply, CMOS Operational Amplifiers

1 Features

- Typical unless otherwise noted
- LMC6035 in DSBGA package
- Specified 2.7V, 3V, 5V, and 15V performance
- Specified for 2kΩ and 600Ω loads
- Wide operating range: 2.0V to 15.5V
- Ultra-low input current: 20fA
- Rail-to-rail output swing
 - At 600Ω: 200mV from either rail at 2.7V
 - At 100kΩ: 5mV from either rail at 2.7V
- High voltage gain: 126dB
- Wide input common-mode voltage range
 - -0.1V to +2.3V at $V_S = 2.7V$
- Low distortion: 0.01% at 10kHz
- LMC6035 dual LMC6036 quad
- See AN-1112 (literature number [SNVA009](#)) for DSBGA considerations
- AEC-Q100 Grade 3 qualified with [LMC6035-Q1](#)

2 Applications

- Filters
- High-impedance buffer or preamplifier
- Battery-powered electronics
- Medical instrumentation

3 Description

The LMC6035 and LMC6036 (LMC603x) are economical, low-voltage op amps capable of rail-to-rail output swing into loads of 600Ω. The LMC6035 is available in a chip-sized package (8-bump DSBGA)

using micro SMD package technology. Both devices allow for single-supply operation and are specified for 2.7V, 3V, 5V, and 15V supply voltage. The 2.7V supply voltage corresponds to the end-of-life voltage (0.9V/cell) for three NiCd or NiMH batteries in series, making the LMC603x an excellent choice for portable and rechargeable systems. These devices also feature a well behaved decrease in specifications at supply voltages less than the specified 2.7V operation. This behavior provides a *comfort zone* for adequate operation at voltages significantly less than 2.7V. The ultra-low input current makes these devices an excellent choice for low-power, active-filter applications because a low input bias current allows the use of higher resistor values and lower capacitor values. In addition, the drive capability of the LMC603x makes these op amps an excellent choice in a broad range of applications for low-voltage systems.

Device Information

PART NUMBER	CHANNEL COUNT	PACKAGE ⁽¹⁾
LMC6035	Dual	D (SOIC, 8)
		DGK (VSSOP, 8)
		YAF (DSBGA, 8)
		YZR (DSBGA, 8)
LMC6036	Quad	D (SOIC, 14)
		PW (TSSOP, 14)

(1) For more information, see [Section 10](#).

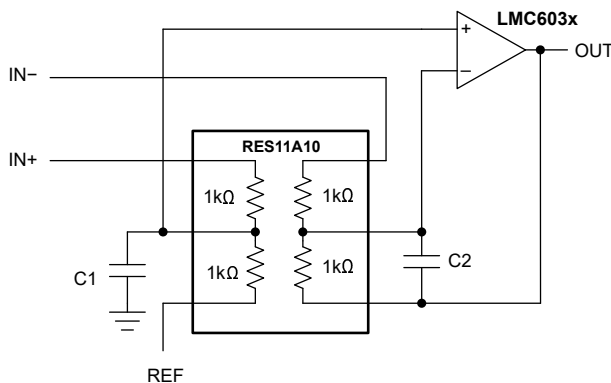

Difference Amplifier Application With RES11

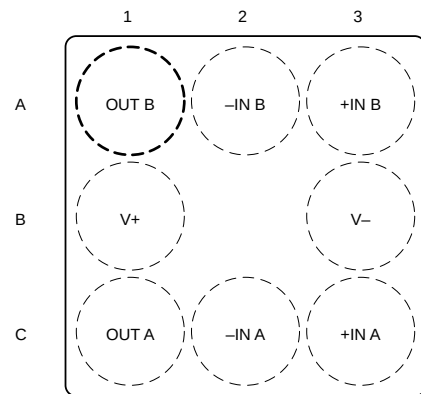

8-Bump DSBGA Package (Bump Side Down)—See Package Number YAF0008



Table of Contents

1 Features	1	6.2 Functional Block Diagram.....	16
2 Applications	1	7 Application and Implementation	17
3 Description	1	7.1 Application Information.....	17
4 Pin Configuration and Functions	3	7.2 Typical Applications.....	18
5 Specifications	5	7.3 Layout.....	23
5.1 Absolute Maximum Ratings.....	5	8 Device and Documentation Support	25
5.2 ESD Ratings.....	5	8.1 Receiving Notification of Documentation Updates....	25
5.3 Recommended Operating Conditions.....	5	8.2 Support Resources.....	25
5.4 Thermal Information: LMC6035.....	6	8.3 Electrostatic Discharge Caution.....	25
5.5 Thermal Information: LMC6036.....	6	8.4 Glossary.....	25
5.6 Electrical Characteristics.....	7	9 Revision History	25
5.7 Typical Characteristics.....	9	10 Mechanical, Packaging, and Orderable	
6 Detailed Description	16	Information.....	26
6.1 Overview.....	16		

4 Pin Configuration and Functions

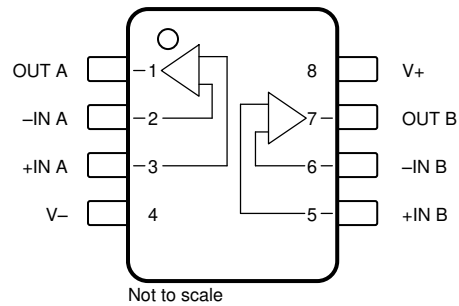

Figure 4-1. LMC6035 D Package, 8-Pin SOIC, and DGK Package, 8-Pin VSSOP (Top View)

Table 4-1. Pin Functions: LMC6035 D and DGK Packages

PIN		TYPE	DESCRIPTION
NAME	NO.		
-IN A	2	Input	Inverting input channel A
-IN B	6	Input	Inverting input channel B
+IN A	3	Input	Noninverting input channel A
+IN B	5	Input	Noninverting input channel B
OUT A	1	Output	Output channel A
OUT B	7	Output	Output channel B
V-	4	Power	Negative supply
V+	8	Power	Positive supply

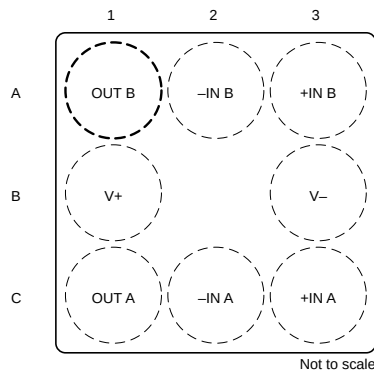

Figure 4-2. LMC6035 YZR Package, 8-Pin DSBGA and YAF Package, 8-Pin DSBGA (Top View)

Table 4-2. Pin Functions: LMC6035 YZR and YAF packages

PIN		TYPE	DESCRIPTION
NAME	NO.		
-IN A	C2	Input	Inverting input channel A
-IN B	A2	Input	Inverting input channel B
+IN A	C3	Input	Noninverting input channel A
+IN B	A3	Input	Noninverting input channel B
OUT A	C1	Output	Output channel A
OUT B	A1	Output	Output channel B
V-	B3	Power	Negative supply
V+	B1	Power	Positive supply

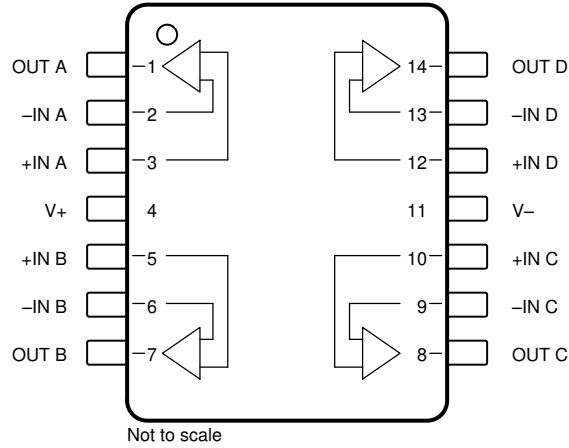

Figure 4-3. LMC6036 D Package, 14-Pin SOIC, and PW Package, 14-Pin TSSOP (Top View)

Table 4-3. Pin Functions: LMC6036

PIN		TYPE	DESCRIPTION
NAME	NO.		
-IN A	2	Input	Inverting input channel A
-IN B	6	Input	Inverting input channel B
-IN C	9	Input	Inverting input channel C
-IN D	13	Input	Inverting input channel D
+IN A	3	Input	Noninverting input channel A
+IN B	5	Input	Noninverting input channel B
+IN C	10	Input	Noninverting input channel C
+IN D	12	Input	Noninverting input channel D
OUT A	1	Output	Output channel A
OUT B	7	Output	Output channel B
OUT C	8	Output	Output channel C
OUT D	14	Output	Output channel D
V-	11	Power	Negative supply
V+	4	Power	Positive supply

5 Specifications

5.1 Absolute Maximum Ratings

over operating free-air temperature range (unless otherwise noted)^{(1) (2)}

		MIN	MAX	UNIT
	Differential input voltage		±Supply voltage	V
V _S	Supply voltage, V _S = (V+) – (V–)	0	16	V
I _{SC}	Output short circuit	To V+	See ⁽³⁾	mA
		To V–	See ⁽⁴⁾	
	Voltage at input pin	(V–) – 0.3	(V+) + 0.3	V
	Current at input pin		±5	mA
	Current at output pin		±18	mA
	Current at power supply pin		35	mA
T _J	Junction temperature ⁽⁵⁾		150	°C
T _{stg}	Storage temperature	–65	150	°C
	Lead temperature (soldering, 10s)		260	°C

- (1) Operation outside the *Absolute Maximum Ratings* may cause permanent device damage. *Absolute Maximum Ratings* do not imply functional operation of the device at these or any other conditions beyond those listed under *Recommended Operating Conditions*. If used outside the *Recommended Operating Conditions* but within the *Absolute Maximum Ratings*, the device may not be fully functional, and this may affect device reliability, functionality, performance, and shorten the device lifetime.
- (2) If Military/Aerospace specified devices are required, please contact the TI Sales Office/Distributors for availability and specifications.
- (3) Do not connect output to V+, when V+ is greater than 13V or reliability is adversely affected.
- (4) Applies to both single-supply and split-supply operation. Continuous short circuit operation at elevated ambient temperature can result in exceeding the maximum allowed junction temperature of 150°C. Output currents in excess of ±30mA over long term adversely affect reliability.
- (5) The maximum power dissipation is a function of T_{J(max)}, θ_{JA}, and T_A. The maximum allowable power dissipation at any ambient temperature is P_D = (T_{J(max)} – T_A) / θ_{JA}

5.2 ESD Ratings

			VALUE	UNIT
V _(ESD)	Electrostatic discharge	Human-body model (HBM), per ANSI/ESDA/JEDEC JS-001 ⁽¹⁾	±3000	V

- (1) JEDEC document JEP155 states that 500V HBM allows safe manufacturing with a standard ESD control process.

5.3 Recommended Operating Conditions

over operating free-air temperature range (unless otherwise noted)

		MIN	NOM	MAX	UNIT
V _S	Supply voltage, V _S = (V+) – (V–)	Single supply	2	15.5	V
		Dual supply	±1	±7.75	
T _J	Junction temperature	–40		85	°C

5.4 Thermal Information: LMC6035

THERMAL METRIC ⁽¹⁾		LMC6035				UNIT
		D (SOIC)	DGK (VSSOP)	YAF (DSBGA)	YZR (DSBGA)	
		8 PINS	8 PINS	8 PINS	8 PINS	
$R_{\theta JA}$	Junction-to-ambient thermal resistance	122.3	149.2	103.1	93.8	°C/W
$R_{\theta JC(top)}$	Junction-to-case(top) thermal resistance	61.4	57.7	0.5	0.5	°C/W
$R_{\theta JB}$	Junction-to-board thermal resistance	70.1	84.1	35.4	26.3	°C/W
Ψ_{JT}	Junction-to-top characterization parameter	11.4	4.4	0.3	0.3	°C/W
Ψ_{JB}	Junction-to-board characterization parameter	69.1	82.9	35.2	26.2	°C/W
$R_{\theta JC(bot)}$	Junction-to-case(bottom) thermal resistance	N/A	N/A	N/A	N/A	°C/W

(1) For more information about traditional and new thermal metrics, see the [Semiconductor and IC Package Thermal Metrics](#) application report.

5.5 Thermal Information: LMC6036

THERMAL METRIC ⁽¹⁾		LMC6036		UNIT
		D (SOIC)	PW (TSSOP)	
		14 PINS	14 PINS	
$R_{\theta JA}$	Junction-to-ambient thermal resistance	83.0	99.5	°C/W
$R_{\theta JC(top)}$	Junction-to-case(top) thermal resistance	42.7	31.3	°C/W
$R_{\theta JB}$	Junction-to-board thermal resistance	42.4	56.4	°C/W
Ψ_{JT}	Junction-to-top characterization parameter	7.0	1.0	°C/W
Ψ_{JB}	Junction-to-board characterization parameter	42.0	55.7	°C/W
$R_{\theta JC(bot)}$	Junction-to-case(bottom) thermal resistance	N/A	N/A	°C/W

(1) For more information about traditional and new thermal metrics, see the [Semiconductor and IC Package Thermal Metrics](#) application report.

5.6 Electrical Characteristics

at $T_J = +25^\circ\text{C}$, $V_+ = 2.7\text{V}$, $V_- = 0\text{V}$, $V_{CM} = 1\text{V}$, $V_{OUT} = V_+ / 2$, and $R_L > 1\text{M}\Omega$ (unless otherwise noted)

PARAMETER		TEST CONDITIONS		MIN	TYP	MAX	UNIT
OFFSET VOLTAGE							
V_{OS}	Input offset voltage				± 0.5	± 5	mV
		$T_J = -40^\circ\text{C}$ to $+85^\circ\text{C}$				± 6	
dV_{OS}/dT	Input offset voltage drift	$T_J = -40^\circ\text{C}$ to $+85^\circ\text{C}$			± 2.3		$\mu\text{V}/^\circ\text{C}$
PSRR	Power-supply rejection ratio	Positive, $5\text{V} \leq V_+ \leq 15\text{V}$		63	93		dB
			$T_J = -40^\circ\text{C}$ to $+85^\circ\text{C}$	60			
		Negative, $0\text{V} \leq V_- \leq -10\text{V}$, $V_O = 2.5\text{V}$, $V_+ = 5\text{V}$		74	97		
			$T_J = -40^\circ\text{C}$ to $+85^\circ\text{C}$	70			
INPUT BIAS CURRENT							
I_B	Input bias current ⁽¹⁾				± 20		fA
		$T_J = -40^\circ\text{C}$ to $+85^\circ\text{C}$				± 90	pA
I_{OS}	Input offset current ⁽¹⁾				± 10		fA
		$T_J = -40^\circ\text{C}$ to $+85^\circ\text{C}$				± 45	pA
NOISE							
e_n	Input voltage noise density	$f = 1\text{kHz}$	$V_+ = 15\text{V}$, $V_{CM} = V_+ / 2$		27		$\text{nV}/\sqrt{\text{Hz}}$
			$V_{CM} = 1\text{V}$		40		
i_n	Input current noise density	$f = 1\text{kHz}$			6		$\text{fA}/\sqrt{\text{Hz}}$
THD	Total harmonic distortion	$f = 10\text{kHz}$, $G = -10\text{V/V}$, $R_L = 2\text{k}\Omega$, $V_{OUT} = 8V_{pp}$, $V_+ = 10\text{V}$			0.01		%
INPUT VOLTAGE							
V_{CM}	Common-mode voltage	To positive rail, For CMRR $\geq 40\text{dB}$		2.0	2.3		V
			$T_J = -40^\circ\text{C}$ to $+85^\circ\text{C}$	1.7			
		To negative rail For CMRR $\geq 40\text{dB}$			-0.1	0.3	
			$T_J = -40^\circ\text{C}$ to $+85^\circ\text{C}$			0.5	
		To positive rail, For CMRR $\geq 40\text{dB}$, $V_+ = 3\text{V}$		2.3	2.6		
			$T_J = -40^\circ\text{C}$ to $+85^\circ\text{C}$	2.0			
		To negative rail For CMRR $\geq 40\text{dB}$, $V_+ = 3\text{V}$			-0.3	0.1	
			$T_J = -40^\circ\text{C}$ to $+85^\circ\text{C}$			0.3	
		To positive rail, For CMRR $\geq 50\text{dB}$, $V_+ = 5\text{V}$		4.2	4.5		
			$T_J = -40^\circ\text{C}$ to $+85^\circ\text{C}$	3.9			
To negative rail For CMRR $\geq 50\text{dB}$, $V_+ = 5\text{V}$			-0.5	-0.2			
	$T_J = -40^\circ\text{C}$ to $+85^\circ\text{C}$			0.0			
To positive rail, For CMRR $\geq 50\text{dB}$, $V_+ = 15\text{V}$		14.0	14.4				
	$T_J = -40^\circ\text{C}$ to $+85^\circ\text{C}$	13.7					
To negative rail For CMRR $\geq 50\text{dB}$, $V_+ = 15\text{V}$			-0.5	-0.2			
	$T_J = -40^\circ\text{C}$ to $+85^\circ\text{C}$			0.0			
CMRR	Common-mode rejection ratio	$V_+ = 15\text{V}$, $0.7\text{V} \leq V_{CM} \leq 12.7\text{V}$		63	96		dB
			$T_J = -40^\circ\text{C}$ to $+85^\circ\text{C}$	60			
INPUT IMPEDANCE							
R_{IN}	Input resistance				> 10		$\text{T}\Omega$

5.6 Electrical Characteristics (continued)

 at $T_J = +25^\circ\text{C}$, $V_+ = 2.7\text{V}$, $V_- = 0\text{V}$, $V_{CM} = 1\text{V}$, $V_{OUT} = V_+ / 2$, and $R_L > 1\text{M}\Omega$ (unless otherwise noted)

PARAMETER		TEST CONDITIONS		MIN	TYP	MAX	UNIT	
OPEN-LOOP GAIN								
A_{OL}	Open-loop voltage gain	Sourcing, $V_+ = 15\text{V}$, $V_{CM} = 7.5\text{V}$, $7.5\text{V} \leq V_O \leq 11.5\text{V}$	$R_L = 2\text{k}\Omega$ to 7.5V		2000		V/mV	
			$R_L = 600\Omega$ to 7.5V	100	1000			
		Sinking, $V_+ = 15\text{V}$, $V_{CM} = 7.5\text{V}$, $3.5\text{V} \leq V_O \leq 7.5\text{V}$	$R_L = 600\Omega$ to 7.5V , $T_J = -40^\circ\text{C}$ to $+85^\circ\text{C}$	75				
			$R_L = 2\text{k}\Omega$ to 7.5V		500			
		$R_L = 600\Omega$ to 7.5V	25	250				
		$R_L = 600\Omega$ to 7.5V , $T_J = -40^\circ\text{C}$ to $+85^\circ\text{C}$	20					
FREQUENCY RESPONSE								
GBW	Gain bandwidth product				1.4		MHz	
SR	Slew rate ⁽²⁾	$V_S = 15\text{V}$, 10V step			1.5		V/ μs	
θ_m	Phase margin				48		°	
G_m	Gain margin				17		dB	
	Crosstalk	Dual and quad channel, $V_+ = 15\text{V}$, $R_L = 100\text{k}\Omega$ to 7.5V , $f = 1\text{kHz}$, $V_{OUT} = 12V_{pp}$			130		dB	
OUTPUT								
V_O	Voltage output swing	To positive rail, $R_L = 2\text{k}\Omega$ to 1.35V	$T_J = -40^\circ\text{C}$ to $+85^\circ\text{C}$	2.4	2.62		V	
			$T_J = -40^\circ\text{C}$ to $+85^\circ\text{C}$	2.2				
		To negative rail, $R_L = 2\text{k}\Omega$ to 1.35V	$T_J = -40^\circ\text{C}$ to $+85^\circ\text{C}$		0.07	0.2		
			$T_J = -40^\circ\text{C}$ to $+85^\circ\text{C}$			0.4		
		To positive rail, $R_L = 600\Omega$ to 1.35V	$T_J = -40^\circ\text{C}$ to $+85^\circ\text{C}$	2.0	2.5			
			$T_J = -40^\circ\text{C}$ to $+85^\circ\text{C}$	1.8				
		To negative rail, $R_L = 600\Omega$ to 1.35V	$T_J = -40^\circ\text{C}$ to $+85^\circ\text{C}$		0.2	0.5		
			$T_J = -40^\circ\text{C}$ to $+85^\circ\text{C}$			0.7		
To positive rail, $V_+ = 15\text{V}$, $R_L = 2\text{k}\Omega$ to 7.5V	$T_J = -40^\circ\text{C}$ to $+85^\circ\text{C}$	14.2	14.8					
	$T_J = -40^\circ\text{C}$ to $+85^\circ\text{C}$	13.5						
To negative rail, $V_+ = 15\text{V}$, $R_L = 2\text{k}\Omega$ to 7.5V	$T_J = -40^\circ\text{C}$ to $+85^\circ\text{C}$		0.12	0.4				
	$T_J = -40^\circ\text{C}$ to $+85^\circ\text{C}$			0.5				
To positive rail, $V_+ = 15\text{V}$, $R_L = 600\Omega$ to 7.5V	$T_J = -40^\circ\text{C}$ to $+85^\circ\text{C}$	13.5	14.5					
	$T_J = -40^\circ\text{C}$ to $+85^\circ\text{C}$	13.0						
To negative rail, $V_+ = 15\text{V}$, $R_L = 600\Omega$ to 7.5V	$T_J = -40^\circ\text{C}$ to $+85^\circ\text{C}$		0.36	1.25				
	$T_J = -40^\circ\text{C}$ to $+85^\circ\text{C}$			1.50				
I_{SC}	Short-circuit current	Sourcing, $V_{OUT} = 0\text{V}$	$T_J = -40^\circ\text{C}$ to $+85^\circ\text{C}$	4	8		mA	
			$T_J = -40^\circ\text{C}$ to $+85^\circ\text{C}$	3				
		Sinking, $V_{OUT} = 2.7\text{V}$	$T_J = -40^\circ\text{C}$ to $+85^\circ\text{C}$	3	5			
		$T_J = -40^\circ\text{C}$ to $+85^\circ\text{C}$	2					
POWER SUPPLY								
I_Q	Quiescent current	LMC6035, $V_{OUT} = 1.5\text{V}$	$T_J = -40^\circ\text{C}$ to $+85^\circ\text{C}$		0.65	1.6	mA	
			$T_J = -40^\circ\text{C}$ to $+85^\circ\text{C}$			1.9		
		LMC6036, $V_{OUT} = 1.5\text{V}$	$T_J = -40^\circ\text{C}$ to $+85^\circ\text{C}$		1.3	2.7		
			$T_J = -40^\circ\text{C}$ to $+85^\circ\text{C}$			3.0		

(1) Specified by design.

(2) Number specified is the slower of the positive and negative slew rates.

5.7 Typical Characteristics

at $V_S = 2.7V$, single supply, and $T_A = 25^\circ C$ (unless otherwise noted)

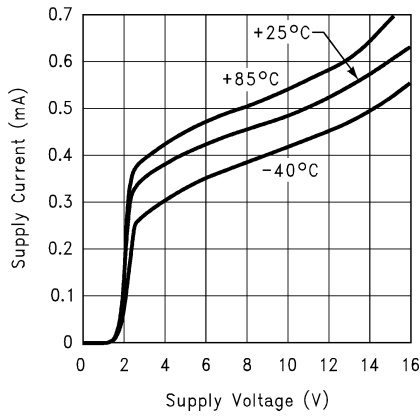

Figure 5-1. Supply Current vs Supply Voltage (Per Amplifier)

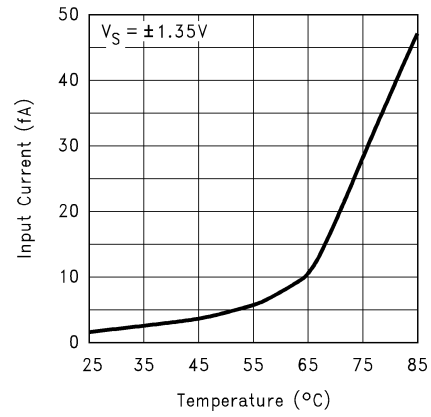

Figure 5-2. Input Bias Current vs Temperature

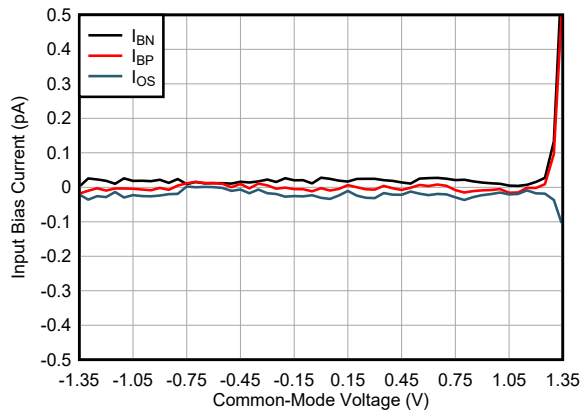

Figure 5-3. Input Bias Current vs Common-Mode Voltage

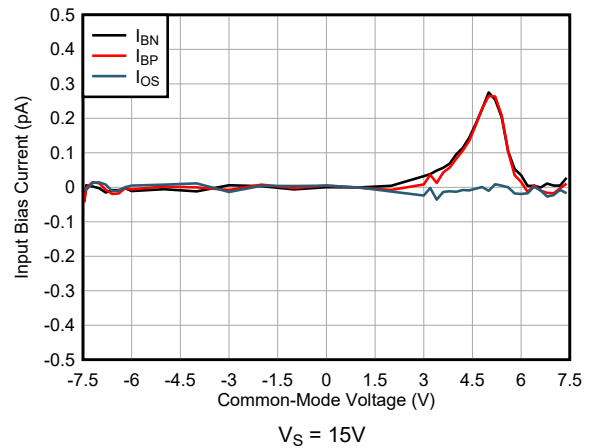

Figure 5-4. Input Current vs Common-Mode Voltage

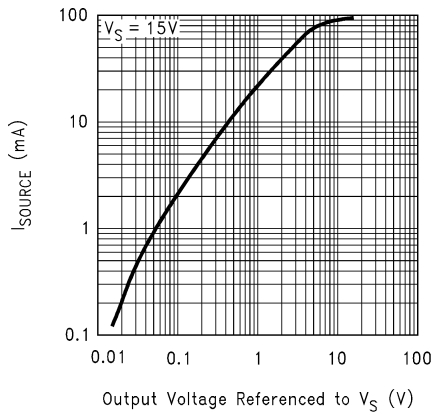

Figure 5-5. Sourcing Current vs Output Voltage

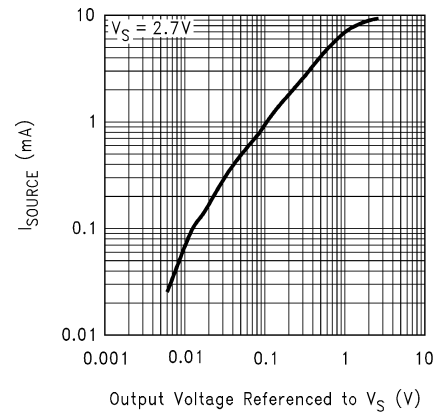

Figure 5-6. Sourcing Current vs Output Voltage

5.7 Typical Characteristics (continued)

at $V_S = 2.7V$, single supply, and $T_A = 25^\circ C$ (unless otherwise noted)

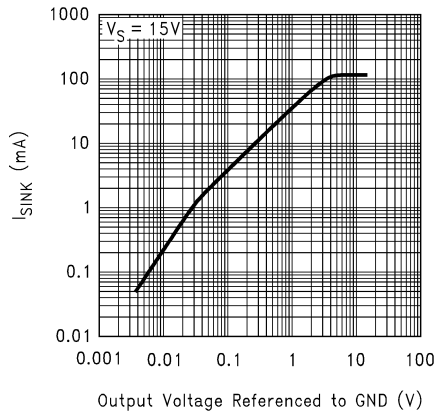

Figure 5-7. Sinking Current vs Output Voltage

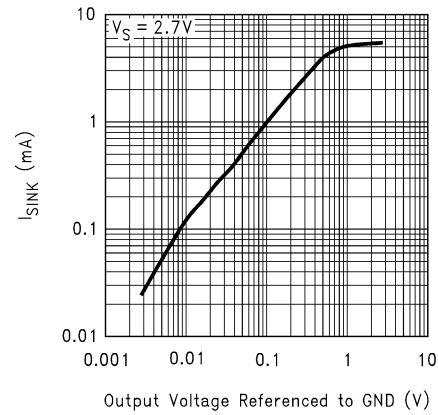

Figure 5-8. Sinking Current vs Output Voltage

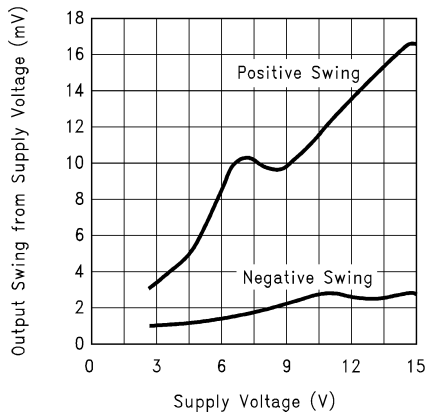

Figure 5-9. Output Voltage Swing vs Supply Voltage

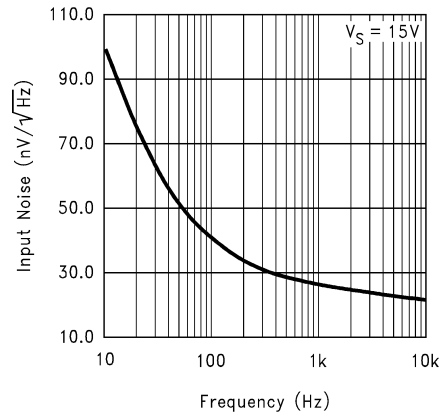

Figure 5-10. Input Noise vs Frequency

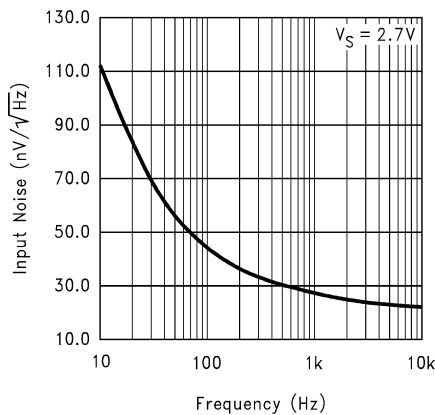

Figure 5-11. Input Noise vs Frequency

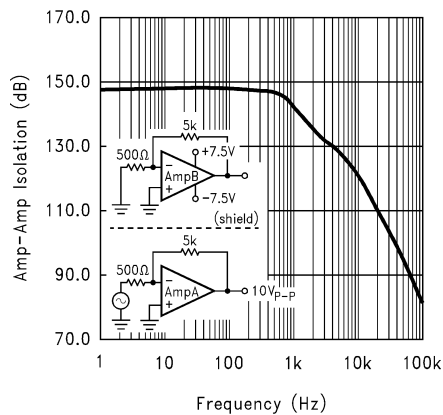

Figure 5-12. Amp to Amp Isolation vs Frequency

5.7 Typical Characteristics (continued)

at $V_S = 2.7V$, single supply, and $T_A = 25^\circ C$ (unless otherwise noted)

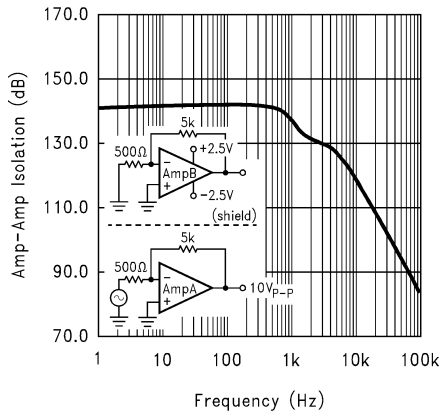

Figure 5-13. Amp to Amp Isolation vs Frequency

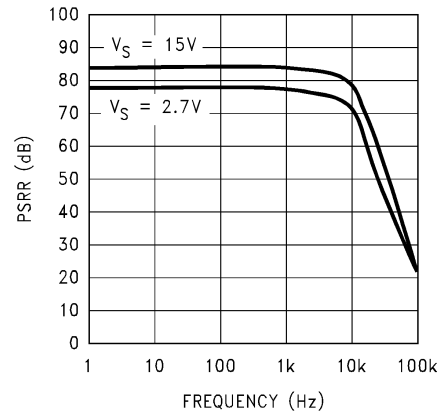

Figure 5-14. +PSRR vs Frequency

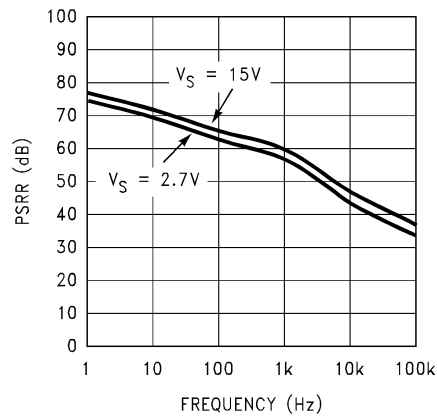

Figure 5-15. -PSRR vs Frequency

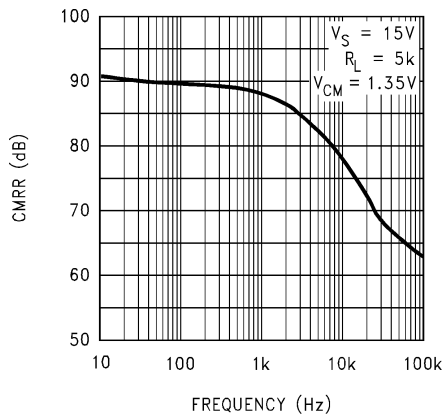

Figure 5-16. CMRR vs Frequency

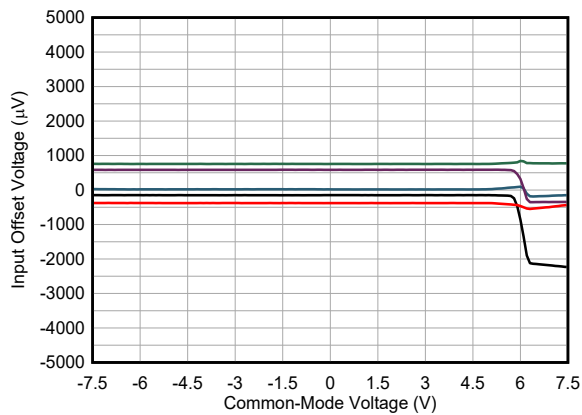

Figure 5-17. Input Offset Voltage vs Common-Mode Voltage

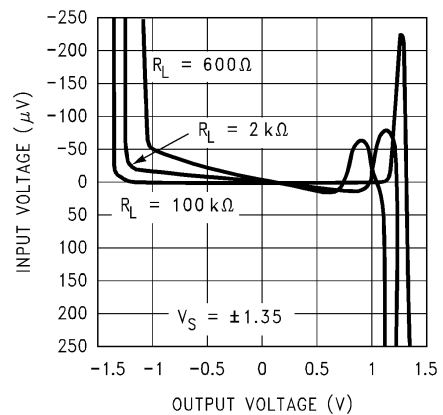

Figure 5-18. Input Voltage vs Output Voltage

5.7 Typical Characteristics (continued)

at $V_S = 2.7V$, single supply, and $T_A = 25^\circ C$ (unless otherwise noted)

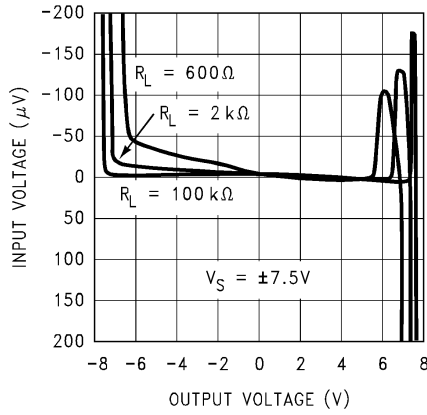

Figure 5-19. Input Voltage vs Output Voltage

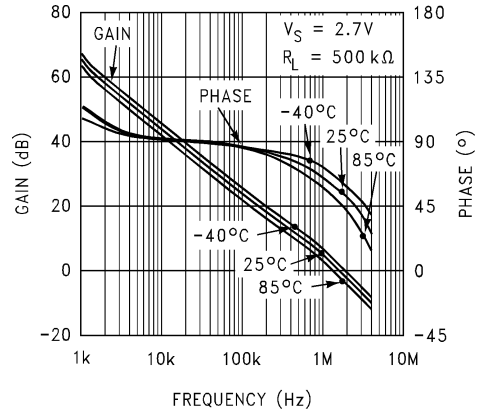

Figure 5-20. Frequency Response vs Temperature

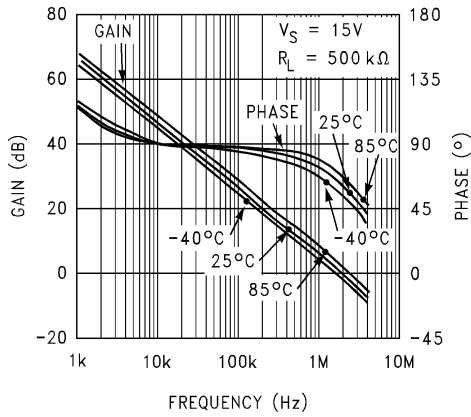

Figure 5-21. Frequency Response vs Temperature

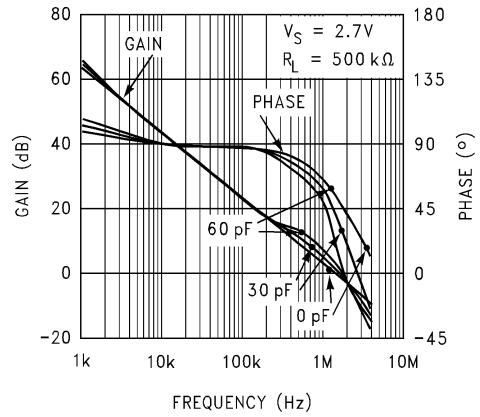

Figure 5-22. Gain and Phase vs Capacitive Load

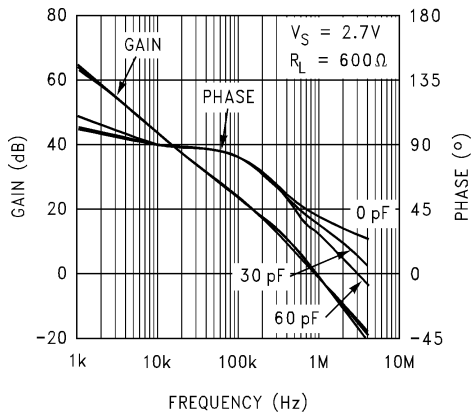

Figure 5-23. Gain and Phase vs Capacitive Load

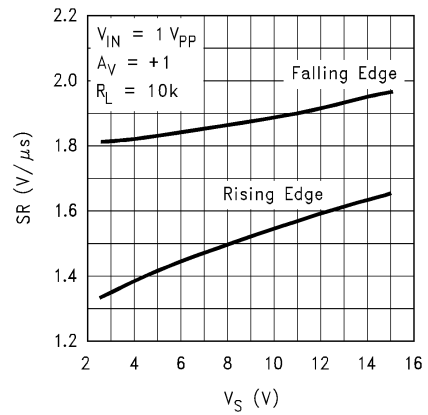

Figure 5-24. Slew Rate vs Supply Voltage

5.7 Typical Characteristics (continued)

at $V_S = 2.7V$, single supply, and $T_A = 25^\circ C$ (unless otherwise noted)

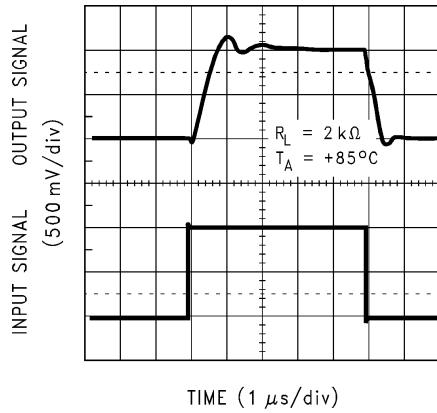

Figure 5-25. Non-Inverting Large Signal Response

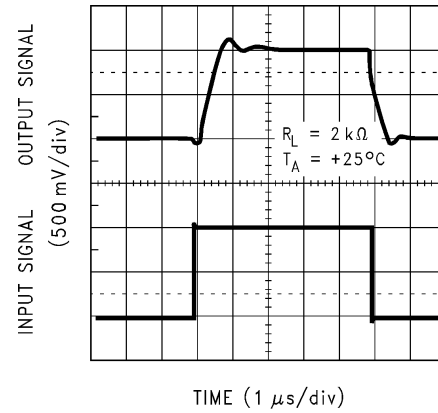

Figure 5-26. Non-Inverting Large Signal Response

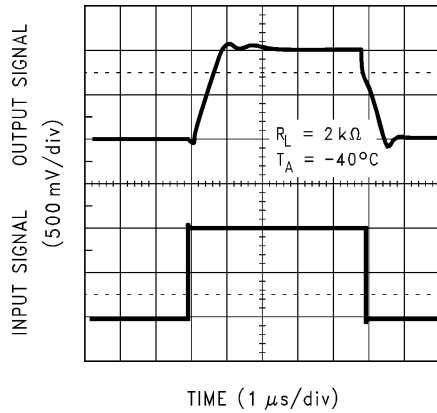

Figure 5-27. Non-Inverting Large Signal Response

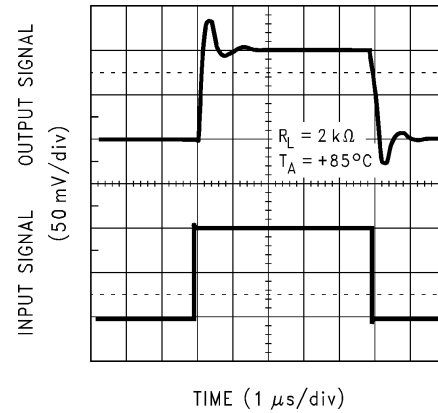

Figure 5-28. Non-Inverting Small Signal Response

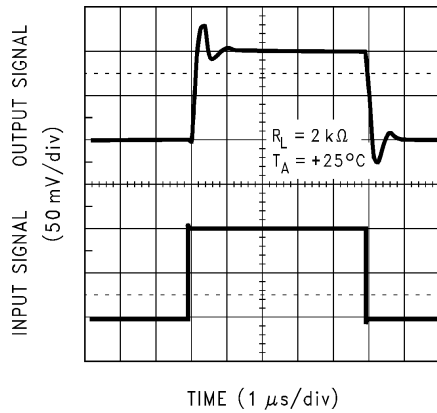

Figure 5-29. Non-Inverting Small Signal Response

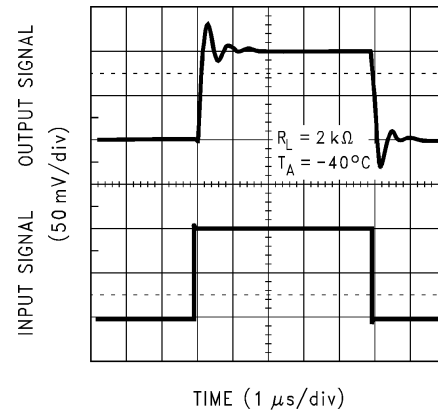

Figure 5-30. Non-Inverting Large Signal Response

5.7 Typical Characteristics (continued)

at $V_S = 2.7V$, single supply, and $T_A = 25^\circ C$ (unless otherwise noted)

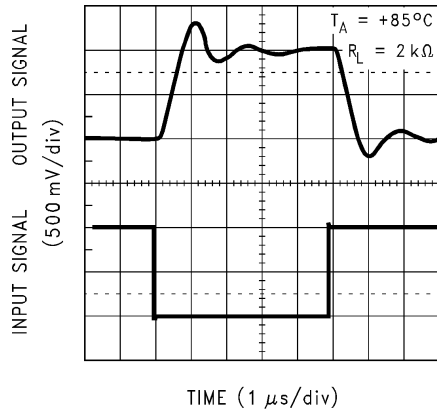

Figure 5-31. Inverting Large Signal Response

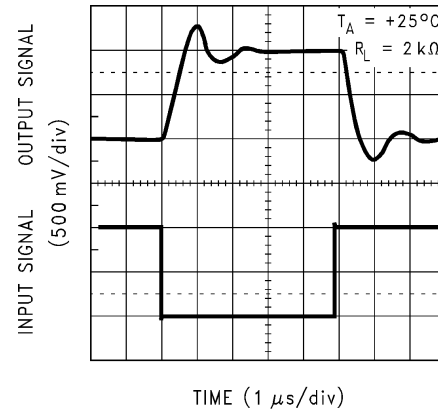

Figure 5-32. Inverting Large Signal Response

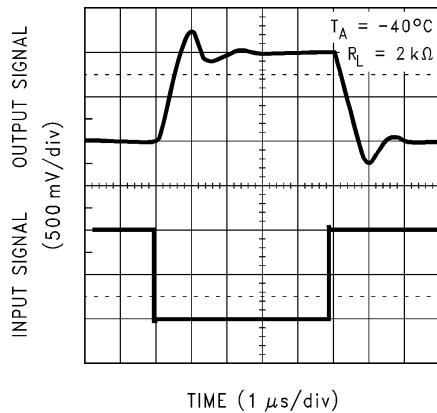

Figure 5-33. Inverting Large Signal Response

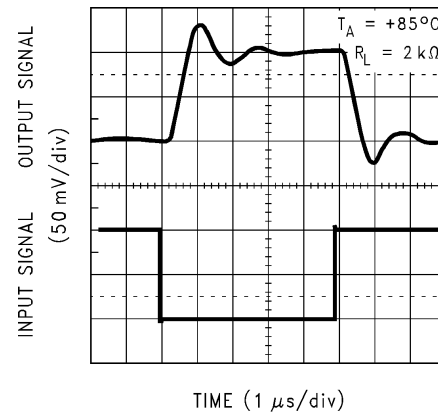

Figure 5-34. Inverting Small Signal Response

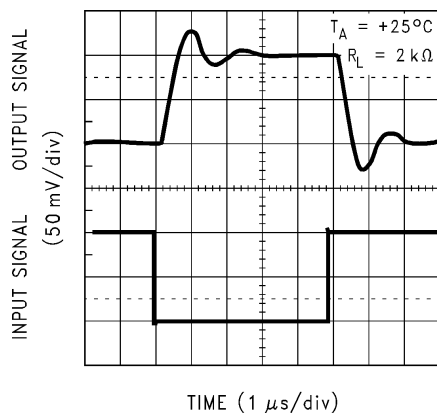

Figure 5-35. Inverting Small Signal Response

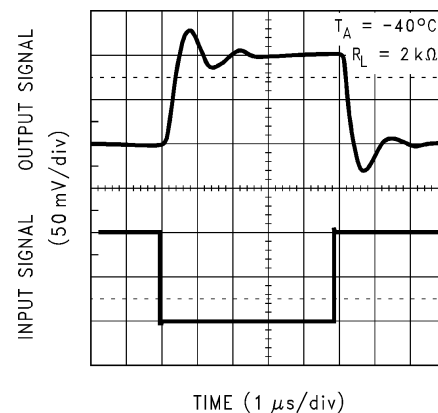

Figure 5-36. Inverting Small Signal Response

5.7 Typical Characteristics (continued)

at $V_S = 2.7V$, single supply, and $T_A = 25^\circ C$ (unless otherwise noted)

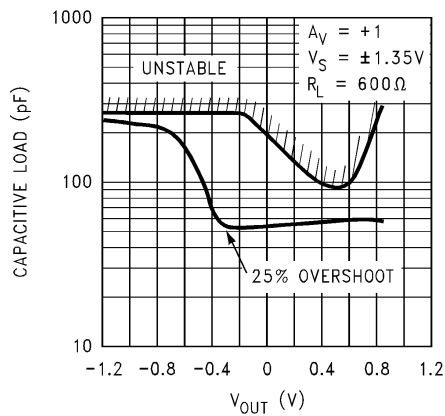

Figure 5-37. Stability vs Capacitive Load

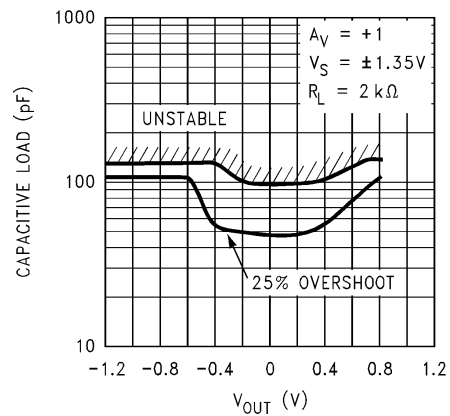

Figure 5-38. Stability vs Capacitive Load

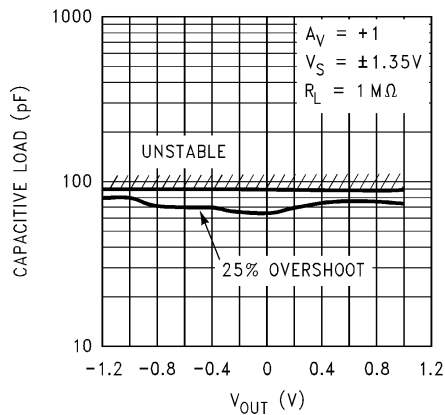

Figure 5-39. Stability vs Capacitive Load

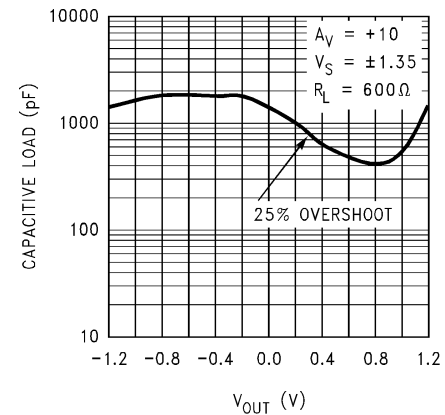

Figure 5-40. Stability vs Capacitive Load

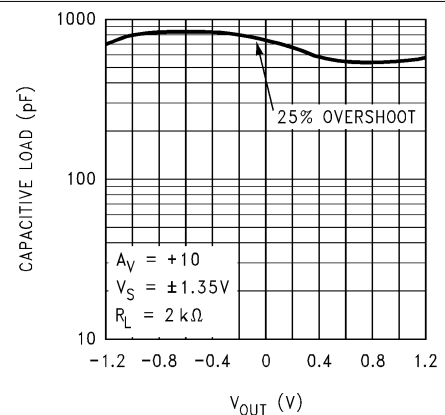

Figure 5-41. Stability vs Capacitive Load

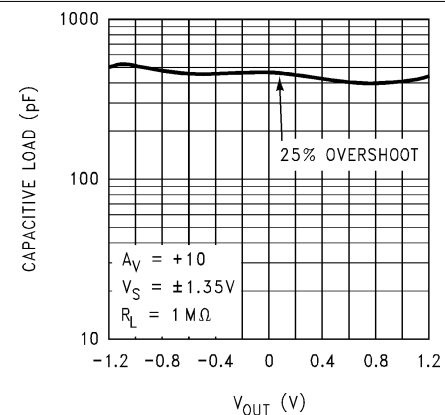

Figure 5-42. Stability vs Capacitive Load

6 Detailed Description

6.1 Overview

The LMC603x operational amplifiers are designed to provide very low leakage current. The femtoampere leakage current level makes these op amps an excellent choice for buffering very high impedance sources. The LMC603x is capable of operating over a wide supply voltage range and as low as 2V. The low supply operation and tiny, die-size ball-grid-array (DSBGA) package make the LMC603x an excellent choice for portable, battery-operated systems.

6.2 Functional Block Diagram

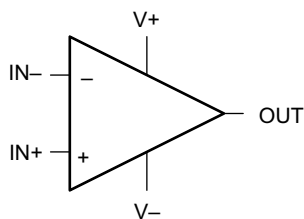

7 Application and Implementation

Note

Information in the following applications sections is not part of the TI component specification, and TI does not warrant its accuracy or completeness. TI's customers are responsible for determining suitability of components for their purposes, as well as validating and testing their design implementation to confirm system functionality.

7.1 Application Information

7.1.1 Capacitive Load Tolerance

Like many other op amps, the LMC603x can oscillate when the applied load appears capacitive. The threshold of oscillation varies both with load and circuit gain. The configuration most sensitive to oscillation is a unity-gain follower. See also [Section 5.7](#).

The load capacitance interacts with the op amp output resistance to create an additional pole. If this pole frequency is sufficiently low, the pole degrades the op amp phase margin so that the amplifier is no longer stable at low gains. [Figure 7-1](#) shows that the addition of a small resistor (50Ω to 100Ω) in series with the op amp output, and a capacitor (5pF to 10pF) from inverting input to output pins, returns the phase margin to a safe value without interfering with lower-frequency circuit operation. Thus, larger values of capacitance can be tolerated without oscillation. In all cases, the output rings heavily when the load capacitance is near the threshold for oscillation.

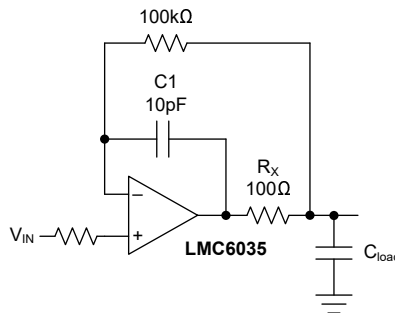

Figure 7-1. R_x , C_x Improve Capacitive Load Tolerance

Capacitive load driving capability is enhanced by using a pullup resistor to $V+$ (shown in [Figure 7-2](#)). Typically a pullup resistor conducting $500\mu\text{A}$ or greater significantly improves capacitive-load responses. The value of the pullup resistor is determined based on the current sinking capability of the amplifier with respect to the desired output swing. The open-loop gain of the amplifier can also be affected by the pullup resistor (see [Section 5.6](#)).

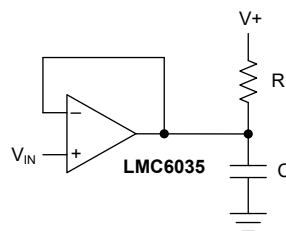

Figure 7-2. Compensating for Large Capacitive Loads With a Pullup Resistor

7.2 Typical Applications

7.2.1 Differential Driver

The LMC603x are an excellent choice for low-voltage applications. A desirable feature that the LMC603x bring to low-voltage applications is the output drive capability—a hallmark for TI's CMOS amplifiers. The circuit of [Figure 7-3](#) illustrates the drive capability of the LMC603x at 3V of supply. These devices are used as a differential output driver for a one-to-one audio transformer, like those used for isolating ground from the telephone lines. The transformer (T1) loads the op amps with about 600Ω of ac load, at 1kHz. Capacitor C1 functions to block dc from the low winding resistance of T1. Although the value of C1 is relatively high, the capacitive load reactance (X_C) is negligible compared to inductive reactance (X_L) of T1.

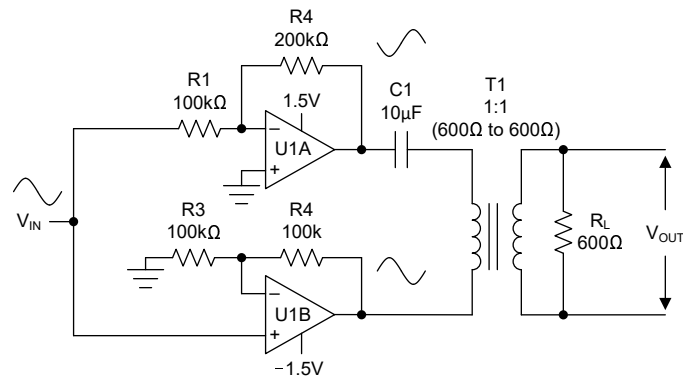

Figure 7-3. Differential Driver

The circuit in [Figure 7-3](#) consists of one input signal and two output signals. U1A amplifies the input with an inverting gain of -2 , while the U1B amplifies the input with a non-inverting gain of $+2$. The two outputs are 180° out of phase with each other; therefore, the gain across the differential output is 4. As the differential output swings between the supply rails, one of the op amps sources the current to the load, while the other op amp sinks the current.

How good a CMOS op amp can sink or source a current is an important factor in determining output swing capability. The output stage of the LMC603x—like many op amps—sources and sinks output current through two complementary transistors in series. This *totem pole* arrangement translates to a channel resistance (R_{dson}) at each supply rail that acts to limit the output swing. Most CMOS op amps are able to swing the outputs very close to the rails; except, however, under the difficult conditions of low supply voltage and heavy load. The LMC603x exhibit exceptional output swing capability under these conditions.

The scope photos of [Figure 7-4](#) and [Figure 7-5](#) represent measurements taken directly at the output (relative to GND) of U1A, in [Figure 7-3](#). [Figure 7-4](#) illustrates the output swing capability of the LMC6035, while [Figure 7-5](#) provides a benchmark comparison. (The benchmark op amp is another low-voltage (3V) op amp manufactured by one of our reputable competitors.)

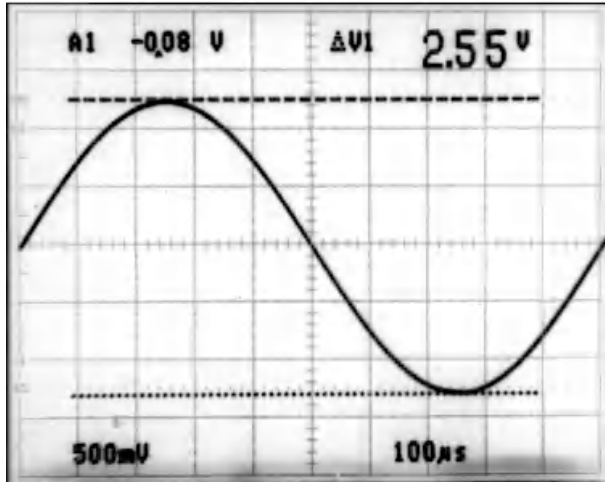

Figure 7-4. Output Swing Performance of the LMC6035 per the Circuit of Figure 7-3

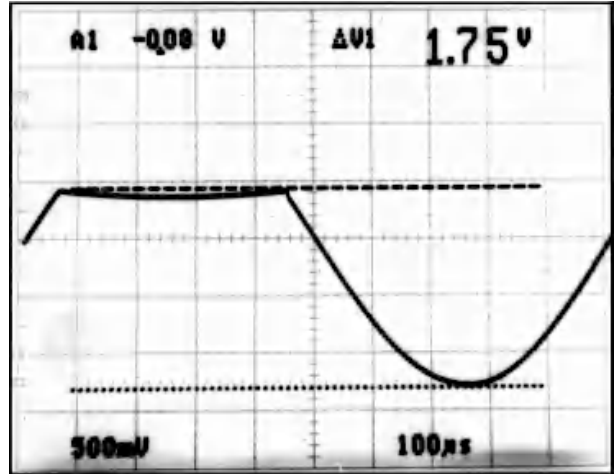

Figure 7-5. Output Swing Performance of Benchmark Op Amp per the Circuit of Figure 7-3

Notice the excellent drive capability of LMC6035 when compared with the benchmark measurement—even though the benchmark op amp uses twice the supply current.

Not only does the LMC603x provide excellent output swing capability at low supply voltages, but these devices also maintain high open-loop gain (A_{OL}) with heavy loads. To illustrate this, the LMC6035 and the benchmark op amp were compared for distortion performance in the circuit of Figure 7-3. Figure 7-6 shows this comparison. The y-axis represents percent total harmonic distortion (THD + noise) across the loaded secondary of T1. The x-axis represents the input amplitude of a 1kHz sine wave. (Notice that T1 loses about 20% of the voltage to the voltage divider of R_L (600 Ω) and T1 winding resistances—a performance deficiency of the transformer.)

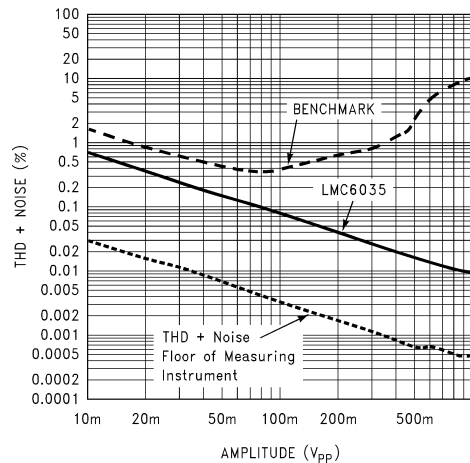

Figure 7-6. THD+Noise Performance of LMC6035 and Benchmark per Circuit of Figure 7-3

Figure 7-6 shows the excellent distortion performance of the LMC603x over that of the benchmark op amp. The heavy loading of the circuit causes the A_{OL} of the benchmark part to drop significantly, which causes increased distortion.

7.2.2 Low-Pass Active Filter

A common application for low voltage systems is active filters, in cordless and cellular phones for example. The ultra low input bias currents (I_B) of the LMC603x makes these op amps an excellent for low power active filter applications, because the low input bias current allows the use of higher resistor values and lower capacitor values. This reduces power consumption and space.

Figure 7-7 shows a low pass, active filter with a Butterworth (maximally flat) frequency response. The topology is a Sallen and Key filter with unity gain. Note the normalized component values in parenthesis which are obtainable from standard filter design handbooks. These values provide a 1Hz cutoff frequency, but can be easily scaled for a desired cutoff frequency (f_c). The bold component values of Figure 7-7 provide a cutoff frequency of 3kHz. An example of the scaling procedure follows Figure 7-7.

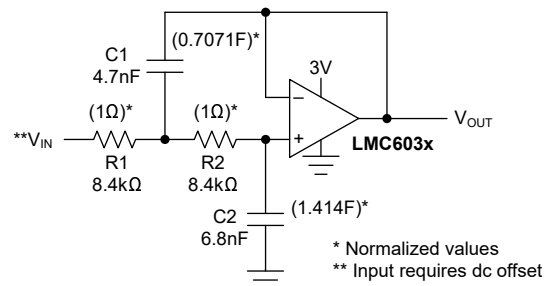

Figure 7-7. 2-Pole, 3kHz, Active, Sallen and Key, Low-Pass Filter With Butterworth Response

7.2.2.1 Low-Pass Frequency Scaling Procedure

The actual component values represented in bold of Figure 7-7 were obtained with the following scaling procedure:

1. First determine the frequency scaling factor (FSF) for the desired cutoff frequency. Choosing f_c at 3kHz, provides the following FSF computation:

$$FSF = 2\pi \times 300\text{kHz} = 18.84\text{k} \quad (1)$$

2. Then divide all of the normalized capacitor values by the FSF as follows ($C1'$ and $C2'$: prior to impedance scaling):

$$C1' = \frac{C1_{\text{normalized}}}{FSF} = \frac{0.707}{18.84\text{k}} = 37.93 \times 10^{-6}\text{F} \quad (2)$$

$$C2' = \frac{C2_{\text{normalized}}}{FSF} = \frac{1.414}{18.84\text{k}} = 75.05 \times 10^{-6}\text{F} \quad (3)$$

3. Last, choose an impedance scaling factor (Z). This Z factor can be calculated from a standard value for $C2$. Then Z can be used to determine the remaining component values as follows:

$$Z = \frac{C2'}{C2_{\text{chosen}}} = \frac{75.05 \times 10^{-6}\text{F}}{6.8\text{nF}} = 8.4\text{k} \quad (4)$$

$$C1 = \frac{C1'}{Z} = \frac{37.93 \times 10^{-6}\text{F}}{8.4\text{k}} = 4.52\text{nF} \quad (5)$$

$$R1 = R1_{\text{normalized}} \times Z = 1\Omega \times 8.4\text{k} = 8.4\text{k}\Omega \quad (6)$$

$$R2 = R2_{\text{normalized}} \times Z = 1\Omega \times 8.4\text{k} = 8.4\text{k}\Omega \quad (7)$$

4. A standard value of 8.45k Ω is chosen for $R1$ and $R2$.

7.2.3 High-Pass Active Filter

The previous low-pass filter circuit of Figure 7-7 converts to a high-pass active filter per Figure 7-8.

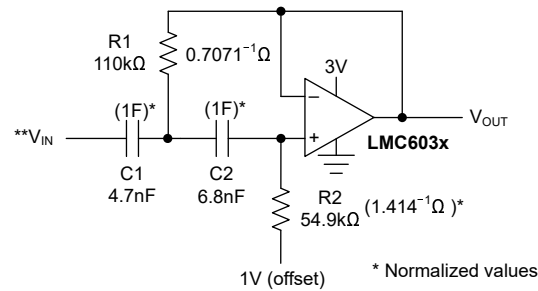

Figure 7-8. 2-Pole, 300Hz, Sallen and Key, High-Pass Filter

7.2.3.1 High-Pass Frequency Scaling Procedure

Choose a standard capacitor value and scale the impedances in the circuit according to the desired cutoff frequency (300Hz) as follows:

$$C = C1 = C2 \tag{8}$$

$$Z = \frac{1}{2\pi f_c C} = \frac{1}{2\pi \times 300\text{Hz} \times 6.8\text{nF}} = 78.05\text{k}\Omega \tag{9}$$

$$R1 = Z \times R1_{\text{normalized}} = 78.05\text{k}\Omega \times \frac{1}{0.707} = 110.4\text{k}\Omega \tag{10}$$

A standard value of 110kΩ is chosen for R1.

$$R2 = Z \times R2_{\text{normalized}} = 78.05\text{k}\Omega \times \frac{1}{1.414} = 55.2\text{k}\Omega \tag{11}$$

A standard value of 54.9kΩ is chosen for R2.

7.2.4 Dual-Amplifier Bandpass Filter

The dual-amplifier bandpass (DABP) filter features the ability to independently adjust f_c and Q . In most other bandpass topologies, the f_c and Q adjustments interact with each other. The DABP filter also offers both low sensitivity to component values and a high Q . The following application of [Figure 7-9](#), provides a 1kHz center frequency and a Q of 100.

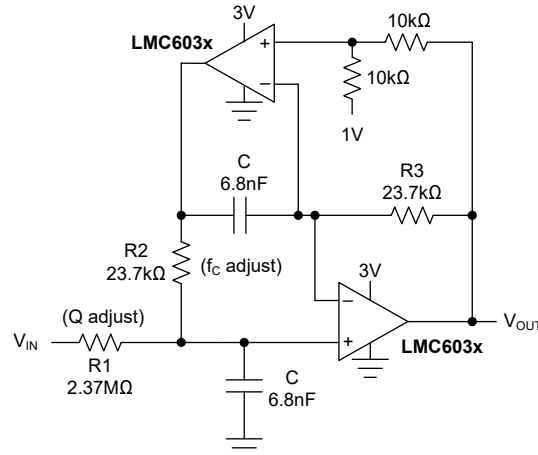

Figure 7-9. Active 2-Pole Bandpass Filter (1kHz)

7.2.4.1 DABP Component Selection Procedure

Component selection for the DABP filter is performed as follows:

1. First choose a center frequency (f_c). [Figure 7-9](#) represents component values that were obtained from the following computation for a center frequency of 1kHz.

$$R2 = R3 = \frac{1}{2\pi f_c C} \quad (12)$$

Given that $f_c = 1\text{kHz}$ and $C_{(\text{chosen})} = 6.8\text{nF}$:

$$R2 = R3 = \frac{1}{2\pi \times 1\text{kHz} \times 6.8\text{nF}} = 23.4\text{k}\Omega \quad (13)$$

A standard value resistor, 23.7kΩ is chosen.

2. Then compute $R1$ for a desired Q (f_c / BW) as follows:

$$R1 = Q \times R2 \quad (14)$$

$$\text{Choosing a } Q \text{ of } 100, \text{ the resistor } R1 \text{ can be computed as follows: } R1 = 100 \times 23.7\text{k}\Omega = 2.37\text{M}\Omega \quad (15)$$

7.3 Layout

7.3.1 Layout Guidelines

7.3.1.1 Printed Circuit Board (PCB) Layout for High-Impedance Work

Any circuit that must operate with $< 1000\text{pA}$ of leakage current requires special layout of the PCB. To take advantage of the ultra-low bias current of the LMC603x (typically $< 0.04\text{pA}$), an excellent layout is essential. Fortunately, the techniques for obtaining low leakages are quite simple. First, do not ignore the surface leakage of the PCB, even though at times the surface leakage can appear acceptably low. Under conditions of high humidity, dust, or contamination, the surface leakage can be appreciable.

To minimize the effect of any surface leakage, lay out a ring of foil completely surrounding the LMC603x inputs and the terminals of capacitors, diodes, conductors, resistors, relay terminals, and so on, connected to the op-amp inputs. See also [Figure 7-14](#). To have a significant effect, place guard rings on both the top and bottom of the PCB. This PCB foil must then be connected to a voltage that is at the same voltage as the amplifier inputs (because no leakage current can flow between two points at the same potential). For example, a PCB trace-to-pad resistance of $10^{12}\Omega$, which is normally considered a very large resistance, can leak 5pA if the trace is a 5V bus adjacent to the pad of an input. This configuration can cause a 100 times degradation from the actual performance of the amplifier. However, if a guard ring is held within 5mV of the inputs, then even a resistance of $10^{11}\Omega$ causes only 0.05pA of leakage current, or perhaps a minor (2:1) degradation of the amplifier performance. See [Figure 7-10](#) through [Figure 7-12](#) for typical connections of guard rings for standard op-amp configurations. If both inputs are active and at high impedance, the guard can be tied to ground and still provide some protection; see also [Figure 7-13](#).

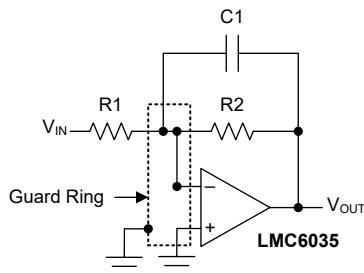

Figure 7-10. Guard Ring Connections: Inverting Amplifier

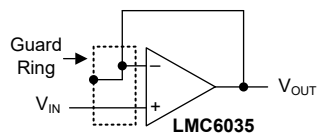

Figure 7-12. Guard Ring Connections: Follower

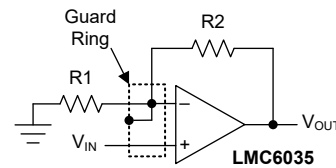

Figure 7-11. Guard Ring Connections: Noninverting Amplifier

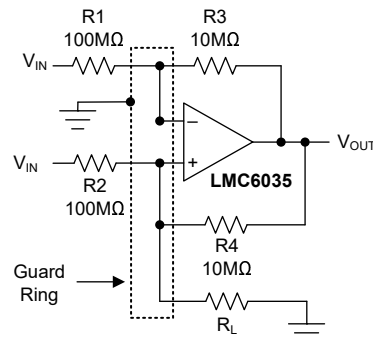

Figure 7-13. Howland Current Pump

A more comprehensive discussion on high impedance circuit design and considerations, see also [Measurement and Calibration Techniques for Ultra-low Current Measurement Systems](#) application note.

7.3.1.2 DSBGA Considerations

Unlike other small packages, the DSBGA package does not follow the trend of smaller packages having greater thermal resistance. The LMC6035 in DSBGA has a thermal resistance of 103.1°C/W compared to 149.2°C/W in VSSOP. Even when driving a 600Ω load and operating from ±7.5V supplies, the maximum temperature rise is less than 2°C. For application information specific to the DSBGA package, see the [AN-1112 DSBGA Wafer Level Chip Scale Package application report](#).

7.3.2 Layout Example

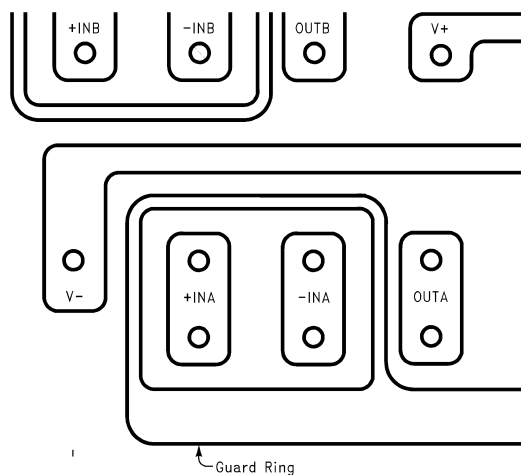

Figure 7-14. Layout Example: Using the LMC603x Guard Ring in PCB Layout

8 Device and Documentation Support

TI offers an extensive line of development tools. Tools and software to evaluate the performance of the device, generate code, and develop solutions are listed below.

8.1 Receiving Notification of Documentation Updates

To receive notification of documentation updates, navigate to the device product folder on ti.com. Click on *Notifications* to register and receive a weekly digest of any product information that has changed. For change details, review the revision history included in any revised document.

8.2 Support Resources

TI E2E™ support forums are an engineer's go-to source for fast, verified answers and design help — straight from the experts. Search existing answers or ask your own question to get the quick design help you need.

Linked content is provided "AS IS" by the respective contributors. They do not constitute TI specifications and do not necessarily reflect TI's views; see TI's [Terms of Use](#).

Trademarks

TI E2E™ is a trademark of Texas Instruments.
All trademarks are the property of their respective owners.

8.3 Electrostatic Discharge Caution



This integrated circuit can be damaged by ESD. Texas Instruments recommends that all integrated circuits be handled with appropriate precautions. Failure to observe proper handling and installation procedures can cause damage.

ESD damage can range from subtle performance degradation to complete device failure. Precision integrated circuits may be more susceptible to damage because very small parametric changes could cause the device not to meet its published specifications.

8.4 Glossary

[TI Glossary](#) This glossary lists and explains terms, acronyms, and definitions.

9 Revision History

NOTE: Page numbers for previous revisions may differ from page numbers in the current version.

Changes from Revision G (April 2013) to Revision H (December 2024)	Page
• Updated the numbering format for tables, figures, and cross-references throughout the document.....	1
• Moved LMC6035-Q1 to a new document.....	1
• Updated <i>Description</i> text for clarity.....	1
• Updated front-page image.....	1
• Added difference amplifier with RES11 application image.....	1
• Added <i>Pin Configuration and Functions</i>	3
• Updated figures and tables in <i>Pin Configuration and Functions</i>	3
• Added input pin voltage to <i>Absolute Maximum Ratings</i>	5
• Added <i>ESD Ratings</i>	5
• Deleted machine model in <i>ESD Ratings</i>	5
• Added Thermal Information.....	6
• Updated junction-to-ambient thermal resistance values.....	6
• Updated parameter names and symbols.....	7
• Added input voltage noise density specification for $V+ = 15V$	7
• Changed input current noise density TYP from $0.2fA/\sqrt{Hz}$ to $6fA/\sqrt{Hz}$	7
• Deleted footnotes 1 and 2 from DC <i>Electrical Characteristics</i>	7
• Moved footnotes 4 into open-loop gain test conditions.....	7
• Deleted footnote 1 from AC <i>Electrical Characteristics</i>	7
• Updated footnote 2 and moved conditions to slew rate test conditions.....	7

• Moved footnote 3 from AC <i>Electrical Characteristics</i> conditions crosstalk test conditions.....	7
• Added Figures 5-3, 5-4, 5-17.....	9
• Deleted Figures 16 and 17.....	9
• Added <i>Overview</i>	16
• Added <i>Functional Block Diagram</i>	16
• Changed A_{VOL} to A_{OL}	18
• Updated Figure 7-7.....	20
• Updated Figure 7-8.....	21
• Updated Figure 7-9.....	22
• Changed the value of f_c from 3kHz to 1kHz to fix error in equation.....	22
• Added reference to <i>Measurement and Calibration Techniques for Ultra-low Current Measurement Systems</i> application note in Printed Circuit Board (PCB) Layout for High-Impedance Work.....	23
• Updated thermal resistance information in <i>DSBGA Considerations</i>	24

10 Mechanical, Packaging, and Orderable Information

The following pages include mechanical, packaging, and orderable information. This information is the most current data available for the designated devices. This data is subject to change without notice and revision of this document. For browser-based versions of this data sheet, refer to the left-hand navigation.

PACKAGING INFORMATION

Orderable Device	Status (1)	Package Type	Package Drawing	Pins	Package Qty	Eco Plan (2)	Lead finish/ Ball material (6)	MSL Peak Temp (3)	Op Temp (°C)	Device Marking (4/5)	Samples
LMC6035IM/NOPB	OBSOLETE	SOIC	D	8		TBD	Call TI	Call TI	-40 to 85	LMC6035IM	
LMC6035IMM/NOPB	ACTIVE	VSSOP	DGK	8	1000	RoHS & Green	SN	Level-1-260C-UNLIM	-40 to 85	A06B	Samples
LMC6035IMMX/NOPB	ACTIVE	VSSOP	DGK	8	3500	RoHS & Green	SN	Level-1-260C-UNLIM	-40 to 85	A06B	Samples
LMC6035IMX/NOPB	ACTIVE	SOIC	D	8	2500	RoHS & Green	SN	Level-1-260C-UNLIM	-40 to 85	LMC6035IM	Samples
LMC6035ITL/NOPB	ACTIVE	DSBGA	YZR	8	250	RoHS & Green	SNAGCU	Level-1-260C-UNLIM	-40 to 85	A80	Samples
LMC6035ITLX/NOPB	ACTIVE	DSBGA	YZR	8	3000	RoHS & Green	SNAGCU	Level-1-260C-UNLIM	-40 to 85	A80	Samples
LMC6035YAFR	ACTIVE	DSBGA	YAF	8	3000	RoHS & Green	SNAGCU	Level-1-260C-UNLIM	-40 to 85	316H	Samples
LMC6036IM/NOPB	OBSOLETE	SOIC	D	14		TBD	Call TI	Call TI	-40 to 85	LMC6036IM	
LMC6036IMTX/NOPB	ACTIVE	TSSOP	PW	14	2500	RoHS & Green	SN	Level-1-260C-UNLIM	-40 to 85	LMC6036IMT	Samples
LMC6036IMX/NOPB	ACTIVE	SOIC	D	14	2500	RoHS & Green	SN	Level-1-260C-UNLIM	-40 to 85	LMC6036IM	Samples

(1) The marketing status values are defined as follows:

ACTIVE: Product device recommended for new designs.

LIFEBUY: TI has announced that the device will be discontinued, and a lifetime-buy period is in effect.

NRND: Not recommended for new designs. Device is in production to support existing customers, but TI does not recommend using this part in a new design.

PREVIEW: Device has been announced but is not in production. Samples may or may not be available.

OBSOLETE: TI has discontinued the production of the device.

(2) **RoHS:** TI defines "RoHS" to mean semiconductor products that are compliant with the current EU RoHS requirements for all 10 RoHS substances, including the requirement that RoHS substance do not exceed 0.1% by weight in homogeneous materials. Where designed to be soldered at high temperatures, "RoHS" products are suitable for use in specified lead-free processes. TI may reference these types of products as "Pb-Free".

RoHS Exempt: TI defines "RoHS Exempt" to mean products that contain lead but are compliant with EU RoHS pursuant to a specific EU RoHS exemption.

Green: TI defines "Green" to mean the content of Chlorine (Cl) and Bromine (Br) based flame retardants meet JS709B low halogen requirements of <=1000ppm threshold. Antimony trioxide based flame retardants must also meet the <=1000ppm threshold requirement.

(3) MSL, Peak Temp. - The Moisture Sensitivity Level rating according to the JEDEC industry standard classifications, and peak solder temperature.

- (4) There may be additional marking, which relates to the logo, the lot trace code information, or the environmental category on the device.
- (5) Multiple Device Markings will be inside parentheses. Only one Device Marking contained in parentheses and separated by a "~" will appear on a device. If a line is indented then it is a continuation of the previous line and the two combined represent the entire Device Marking for that device.
- (6) Lead finish/Ball material - Orderable Devices may have multiple material finish options. Finish options are separated by a vertical ruled line. Lead finish/Ball material values may wrap to two lines if the finish value exceeds the maximum column width.

Important Information and Disclaimer:The information provided on this page represents TI's knowledge and belief as of the date that it is provided. TI bases its knowledge and belief on information provided by third parties, and makes no representation or warranty as to the accuracy of such information. Efforts are underway to better integrate information from third parties. TI has taken and continues to take reasonable steps to provide representative and accurate information but may not have conducted destructive testing or chemical analysis on incoming materials and chemicals. TI and TI suppliers consider certain information to be proprietary, and thus CAS numbers and other limited information may not be available for release.

In no event shall TI's liability arising out of such information exceed the total purchase price of the TI part(s) at issue in this document sold by TI to Customer on an annual basis.

OTHER QUALIFIED VERSIONS OF LMC6035 :

- Automotive : [LMC6035-Q1](#)

NOTE: Qualified Version Definitions:

- Automotive - Q100 devices qualified for high-reliability automotive applications targeting zero defects

TAPE AND REEL INFORMATION

QUADRANT ASSIGNMENTS FOR PIN 1 ORIENTATION IN TAPE

*All dimensions are nominal

Device	Package Type	Package Drawing	Pins	SPQ	Reel Diameter (mm)	Reel Width W1 (mm)	A0 (mm)	B0 (mm)	K0 (mm)	P1 (mm)	W (mm)	Pin1 Quadrant
LMC6035IMM/NOPB	VSSOP	DGK	8	1000	178.0	12.4	5.3	3.4	1.4	8.0	12.0	Q1
LMC6035IMMX/NOPB	VSSOP	DGK	8	3500	330.0	12.4	5.3	3.4	1.4	8.0	12.0	Q1
LMC6035IMX/NOPB	SOIC	D	8	2500	330.0	12.4	6.5	5.4	2.0	8.0	12.0	Q1
LMC6035ITL/NOPB	DSBGA	YZR	8	250	178.0	8.4	1.85	2.01	0.76	4.0	8.0	Q1
LMC6035ITLX/NOPB	DSBGA	YZR	8	3000	178.0	8.4	1.85	2.01	0.76	4.0	8.0	Q1
LMC6036IMTX/NOPB	TSSOP	PW	14	2500	330.0	12.4	6.95	5.6	1.6	8.0	12.0	Q1
LMC6036IMX/NOPB	SOIC	D	14	2500	330.0	16.4	6.5	9.35	2.3	8.0	16.0	Q1

TAPE AND REEL BOX DIMENSIONS



*All dimensions are nominal

Device	Package Type	Package Drawing	Pins	SPQ	Length (mm)	Width (mm)	Height (mm)
LMC6035IMM/NOPB	VSSOP	DGK	8	1000	208.0	191.0	35.0
LMC6035IMMX/NOPB	VSSOP	DGK	8	3500	367.0	367.0	35.0
LMC6035IMX/NOPB	SOIC	D	8	2500	367.0	367.0	35.0
LMC6035ITL/NOPB	DSBGA	YZR	8	250	208.0	191.0	35.0
LMC6035ITLX/NOPB	DSBGA	YZR	8	3000	208.0	191.0	35.0
LMC6036IMTX/NOPB	TSSOP	PW	14	2500	367.0	367.0	35.0
LMC6036IMX/NOPB	SOIC	D	14	2500	367.0	367.0	35.0

DGK0008A



PACKAGE OUTLINE

VSSOP - 1.1 mm max height

SMALL OUTLINE PACKAGE



4214862/A 04/2023

NOTES:

PowerPAD is a trademark of Texas Instruments.

1. All linear dimensions are in millimeters. Any dimensions in parenthesis are for reference only. Dimensioning and tolerancing per ASME Y14.5M.
2. This drawing is subject to change without notice.
3. This dimension does not include mold flash, protrusions, or gate burrs. Mold flash, protrusions, or gate burrs shall not exceed 0.15 mm per side.
4. This dimension does not include interlead flash. Interlead flash shall not exceed 0.25 mm per side.
5. Reference JEDEC registration MO-187.

EXAMPLE BOARD LAYOUT

DGK0008A

™ VSSOP - 1.1 mm max height

SMALL OUTLINE PACKAGE



LAND PATTERN EXAMPLE
EXPOSED METAL SHOWN
SCALE: 15X



SOLDER MASK DETAILS

4214862/A 04/2023

NOTES: (continued)

6. Publication IPC-7351 may have alternate designs.
7. Solder mask tolerances between and around signal pads can vary based on board fabrication site.
8. Vias are optional depending on application, refer to device data sheet. If any vias are implemented, refer to their locations shown on this view. It is recommended that vias under paste be filled, plugged or tented.
9. Size of metal pad may vary due to creepage requirement.

EXAMPLE STENCIL DESIGN

DGK0008A

™ VSSOP - 1.1 mm max height

SMALL OUTLINE PACKAGE



SOLDER PASTE EXAMPLE
SCALE: 15X

4214862/A 04/2023

NOTES: (continued)

11. Laser cutting apertures with trapezoidal walls and rounded corners may offer better paste release. IPC-7525 may have alternate design recommendations.
12. Board assembly site may have different recommendations for stencil design.

YZR0008

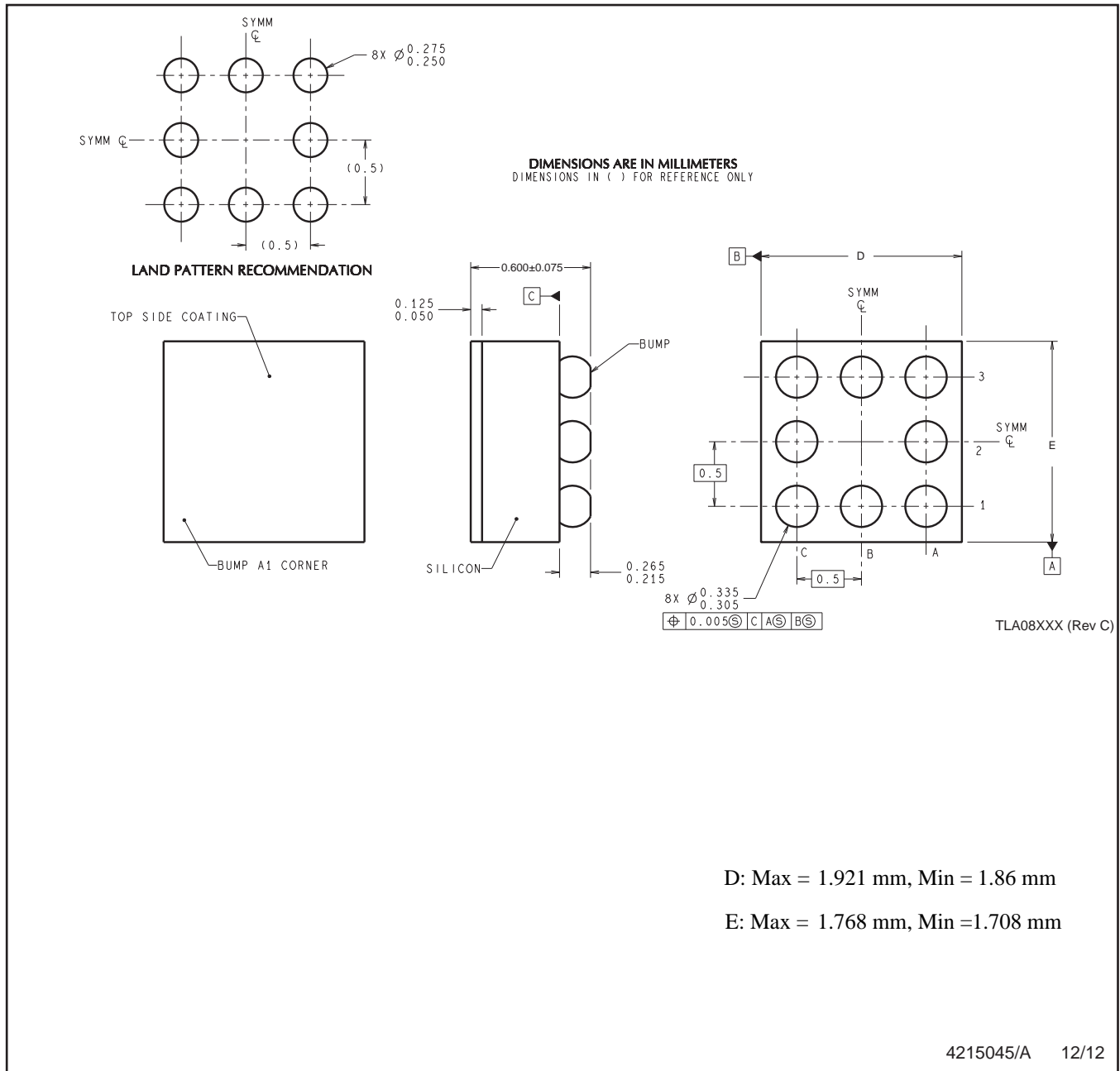

NOTES: A. All linear dimensions are in millimeters. Dimensioning and tolerancing per ASME Y14.5M-1994.
 B. This drawing is subject to change without notice.

4215045/A 12/12



D0014A

PACKAGE OUTLINE

SOIC - 1.75 mm max height

SMALL OUTLINE INTEGRATED CIRCUIT



4220718/A 09/2016

NOTES:

1. All linear dimensions are in millimeters. Dimensions in parenthesis are for reference only. Dimensioning and tolerancing per ASME Y14.5M.
2. This drawing is subject to change without notice.
3. This dimension does not include mold flash, protrusions, or gate burrs. Mold flash, protrusions, or gate burrs shall not exceed 0.15 mm, per side.
4. This dimension does not include interlead flash. Interlead flash shall not exceed 0.43 mm, per side.
5. Reference JEDEC registration MS-012, variation AB.

EXAMPLE BOARD LAYOUT

D0014A

SOIC - 1.75 mm max height

SMALL OUTLINE INTEGRATED CIRCUIT



LAND PATTERN EXAMPLE
SCALE:8X



SOLDER MASK DETAILS

4220718/A 09/2016

NOTES: (continued)

- 6. Publication IPC-7351 may have alternate designs.
- 7. Solder mask tolerances between and around signal pads can vary based on board fabrication site.

EXAMPLE STENCIL DESIGN

D0014A

SOIC - 1.75 mm max height

SMALL OUTLINE INTEGRATED CIRCUIT



SOLDER PASTE EXAMPLE
BASED ON 0.125 mm THICK STENCIL
SCALE:8X

4220718/A 09/2016

NOTES: (continued)

8. Laser cutting apertures with trapezoidal walls and rounded corners may offer better paste release. IPC-7525 may have alternate design recommendations.
9. Board assembly site may have different recommendations for stencil design.



D0008A

PACKAGE OUTLINE

SOIC - 1.75 mm max height

SMALL OUTLINE INTEGRATED CIRCUIT



4214825/C 02/2019

NOTES:

- Linear dimensions are in inches [millimeters]. Dimensions in parenthesis are for reference only. Controlling dimensions are in inches. Dimensioning and tolerancing per ASME Y14.5M.
- This drawing is subject to change without notice.
- This dimension does not include mold flash, protrusions, or gate burrs. Mold flash, protrusions, or gate burrs shall not exceed $.006$ [0.15] per side.
- This dimension does not include interlead flash.
- Reference JEDEC registration MS-012, variation AA.

EXAMPLE BOARD LAYOUT

D0008A

SOIC - 1.75 mm max height

SMALL OUTLINE INTEGRATED CIRCUIT



LAND PATTERN EXAMPLE
 EXPOSED METAL SHOWN
 SCALE:8X



SOLDER MASK DETAILS

4214825/C 02/2019

NOTES: (continued)

6. Publication IPC-7351 may have alternate designs.

7. Solder mask tolerances between and around signal pads can vary based on board fabrication site.

EXAMPLE STENCIL DESIGN

D0008A

SOIC - 1.75 mm max height

SMALL OUTLINE INTEGRATED CIRCUIT



SOLDER PASTE EXAMPLE
BASED ON .005 INCH [0.125 MM] THICK STENCIL
SCALE:8X

4214825/C 02/2019

NOTES: (continued)

8. Laser cutting apertures with trapezoidal walls and rounded corners may offer better paste release. IPC-7525 may have alternate design recommendations.
9. Board assembly site may have different recommendations for stencil design.



4220202/B 12/2023

NOTES:

1. All linear dimensions are in millimeters. Any dimensions in parenthesis are for reference only. Dimensioning and tolerancing per ASME Y14.5M.
2. This drawing is subject to change without notice.
3. This dimension does not include mold flash, protrusions, or gate burrs. Mold flash, protrusions, or gate burrs shall not exceed 0.15 mm per side.
4. This dimension does not include interlead flash. Interlead flash shall not exceed 0.25 mm per side.
5. Reference JEDEC registration MO-153.

EXAMPLE BOARD LAYOUT

PW0014A

TSSOP - 1.2 mm max height

SMALL OUTLINE PACKAGE

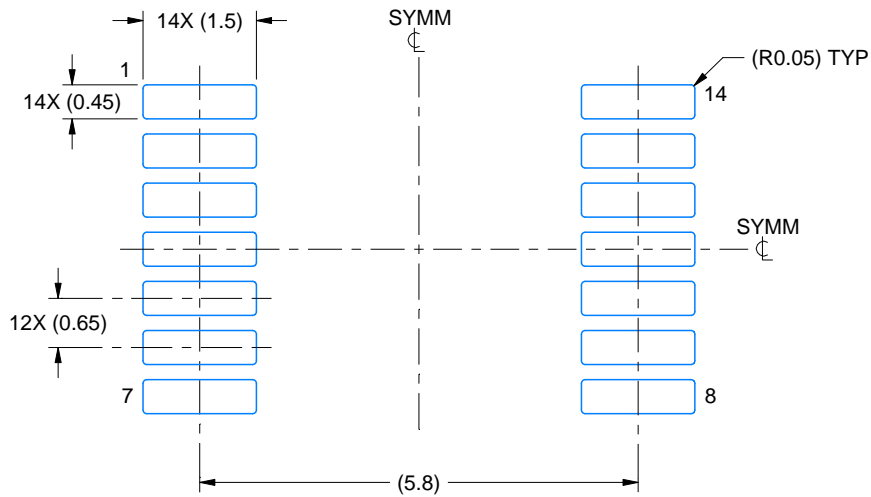

LAND PATTERN EXAMPLE
EXPOSED METAL SHOWN
SCALE: 10X

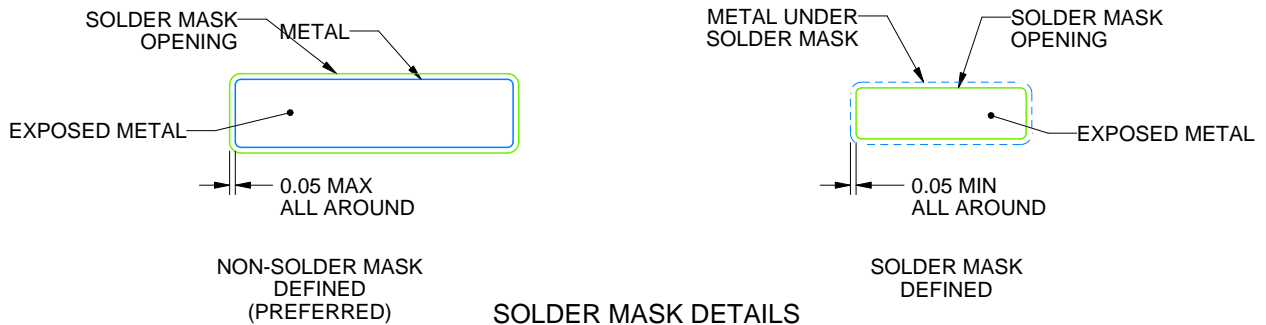

4220202/B 12/2023

NOTES: (continued)

- 6. Publication IPC-7351 may have alternate designs.
- 7. Solder mask tolerances between and around signal pads can vary based on board fabrication site.

EXAMPLE STENCIL DESIGN

PW0014A

TSSOP - 1.2 mm max height

SMALL OUTLINE PACKAGE



SOLDER PASTE EXAMPLE
BASED ON 0.125 mm THICK STENCIL
SCALE: 10X

4220202/B 12/2023

NOTES: (continued)

8. Laser cutting apertures with trapezoidal walls and rounded corners may offer better paste release. IPC-7525 may have alternate design recommendations.
9. Board assembly site may have different recommendations for stencil design.

IMPORTANT NOTICE AND DISCLAIMER

TI PROVIDES TECHNICAL AND RELIABILITY DATA (INCLUDING DATA SHEETS), DESIGN RESOURCES (INCLUDING REFERENCE DESIGNS), APPLICATION OR OTHER DESIGN ADVICE, WEB TOOLS, SAFETY INFORMATION, AND OTHER RESOURCES "AS IS" AND WITH ALL FAULTS, AND DISCLAIMS ALL WARRANTIES, EXPRESS AND IMPLIED, INCLUDING WITHOUT LIMITATION ANY IMPLIED WARRANTIES OF MERCHANTABILITY, FITNESS FOR A PARTICULAR PURPOSE OR NON-INFRINGEMENT OF THIRD PARTY INTELLECTUAL PROPERTY RIGHTS.

These resources are intended for skilled developers designing with TI products. You are solely responsible for (1) selecting the appropriate TI products for your application, (2) designing, validating and testing your application, and (3) ensuring your application meets applicable standards, and any other safety, security, regulatory or other requirements.

These resources are subject to change without notice. TI grants you permission to use these resources only for development of an application that uses the TI products described in the resource. Other reproduction and display of these resources is prohibited. No license is granted to any other TI intellectual property right or to any third party intellectual property right. TI disclaims responsibility for, and you will fully indemnify TI and its representatives against, any claims, damages, costs, losses, and liabilities arising out of your use of these resources.

TI's products are provided subject to [TI's Terms of Sale](#) or other applicable terms available either on [ti.com](https://www.ti.com) or provided in conjunction with such TI products. TI's provision of these resources does not expand or otherwise alter TI's applicable warranties or warranty disclaimers for TI products.

TI objects to and rejects any additional or different terms you may have proposed.

Mailing Address: Texas Instruments, Post Office Box 655303, Dallas, Texas 75265
Copyright © 2025, Texas Instruments Incorporated